

带有外部电池加热器控制和 LCD 显示屏已启用 Impedance Track™ 技术的 SBS 1.1 兼容电池电量计和保护电路

查询样品: **bq34z653**

特性

- 已为下一代产品申请专利 **Impedance Track™** 技术可准确测量锂离子和锂聚合物电池中的可用电量
 - 在电池使用寿命范围内小于 **1%** 的误差
- 支持智能电池技术规范 **SBS V1.1**
- **2** 节串联至 **4** 节串联锂离子与锂聚合物电池的高灵活配置
- 电池温度加热器控制
- 支持超低功耗模式的强大 **8** 位精简指令集 (**RISC**) **CPU**
- 可编程保护特性的完全阵列
 - 电压、电流、和温度
- 符合 **JEITA** 标准
- 可处理更复杂充电模式的附加灵活性
- 使用寿命的数据记录
- 针对电池组情况, 驱动 **3, 4, 和 5** 段 **LED** 或者 **LCD**
- 支持 **SHA-1** 认证
- 同一封装中的完整电池保护与电量测量解决方案
- 采用 **44** 引脚薄型小外形尺寸 (**TSSOP**) (**DBT**) 封装

应用范围

- 笔记本电脑
- 医疗与测试设备
- 便携式仪表

说明

采用获专利的 **Impedance Track™** 技术的 **bq34z653** **SBS** 标准兼容电量监测计与保护 **IC** 是面向电池组或系统内安装的单一 **IC** 解决方案。 **bq34z653** 使用其集成型高性能模拟外设, 可测量锂离子或锂聚合物电池内的可用电量并保存可用电量的准确记录。 **bq34z653** 可监控容量变化、电池阻抗、开路电压以及其它电池组的关键参数, 可通过一条串行通信总线向系统主机控制器报告信息。 通过与集成型模拟前端 (**AFE**) 短路与过负载保护功能结合在一起, **bq34z653** 在大大提高功能和安全性时还可大大降低智能电池电路的外部组件数量、成本、和尺寸。

所实施的 **Impedance Track™** 电量监测技术可持续地分析电池阻抗, 从而可实现极高精度的电量监测。 这可通过每个周期的每个阶段的放电速率、温度以及电池老化情况精确计算出剩余容量。



Please be aware that an important notice concerning availability, standard warranty, and use in critical applications of Texas Instruments semiconductor products and disclaimers thereto appears at the end of this data sheet.

Impedance Track is a trademark of Texas Instruments.



These devices have limited built-in ESD protection. The leads should be shorted together or the device placed in conductive foam during storage or handling to prevent electrostatic damage to the MOS gates.

Table 1. AVAILABLE OPTIONS

T _A	PACKAGE ⁽¹⁾	
	44-PIN TSSOP (DBT) Tube	44-PIN TSSOP (DBT) Tape and Reel
-40°C to 85°C	bq34z653DBT ⁽²⁾	bq34z653DBTR ⁽³⁾

(1) For the most current package and ordering information, see the Package Option Addendum at the end of this document, or see the TI website at www.ti.com.

(2) A single tube quantity is 40 units.

(3) A single reel quantity is 2000 units.



This integrated circuit can be damaged by ESD. Texas Instruments recommends that all integrated circuits be handled with appropriate precautions. Failure to observe proper handling and installation procedures can cause damage.

ESD damage can range from subtle performance degradation to complete device failure. Precision integrated circuits may be more susceptible to damage because very small parametric changes could cause the device not to meet its published specifications.

THERMAL INFORMATION

THERMAL METRIC ⁽¹⁾		bq34z653		UNITS
		TSSOP		
		44 PINS		
$\theta_{JA, High K}$	Junction-to-ambient thermal resistance ⁽²⁾	60.9		°C/W
$\theta_{JC(top)}$	Junction-to-case(top) thermal resistance ⁽³⁾	15.3		
θ_{JB}	Junction-to-board thermal resistance ⁽⁴⁾	30.2		
ψ_{JT}	Junction-to-top characterization parameter ⁽⁵⁾	0.3		
ψ_{JB}	Junction-to-board characterization parameter ⁽⁶⁾	27.2		
$\theta_{JC(bottom)}$	Junction-to-case(bottom) thermal resistance ⁽⁷⁾	n/a		

(1) 有关传统和全新热度的更多信息，请参阅 *IC 封装热量量 应用报告* (文献号: [SPRA953](#))。

(2) 在 JESD51-2a 描述的环境中，按照 JESD51-7 的规定，在一个 JEDEC 标准高 K 电路板上进行仿真，从而获得自然对流条件下的结至环境热阻抗。

(3) 通过在封装顶部模拟一个冷板测试来获得结至芯片外壳 (顶部) 的热阻。不存在特定的 JEDEC 标准测试，但可在 ANSI SEMI 标准 G30-88 中找到内容接近的说明。

(4) 按照 JESD51-8 中的说明，通过在配有用于控制 PCB 温度的环形冷板夹具的环境中进行仿真，以获得结至电路板的热阻。

(5) 结至顶部的特征参数，(ψ_{JT})，估算真实系统中器件的结温，并使用 JESD51-2a (第 6 章和第 7 章) 中描述的程序从仿真数据中提取出该参数以便获得 θ_{JA} 。

(6) 结至电路板的特征参数，(ψ_{JB})，估算真实系统中器件的结温，并使用 JESD51-2a (第 6 章和第 7 章) 中描述的程序从仿真数据中提取出该参数以便获得 θ_{JA} 。

(7) 通过在外露 (电源) 焊盘上进行冷板测试仿真来获得结至芯片外壳 (底部) 热阻。不存在特定的 JEDEC 标准测试，但可在 ANSI SEMI 标准 G30-88 中找到了内容接近的说明。

TYPICAL APPLICATION

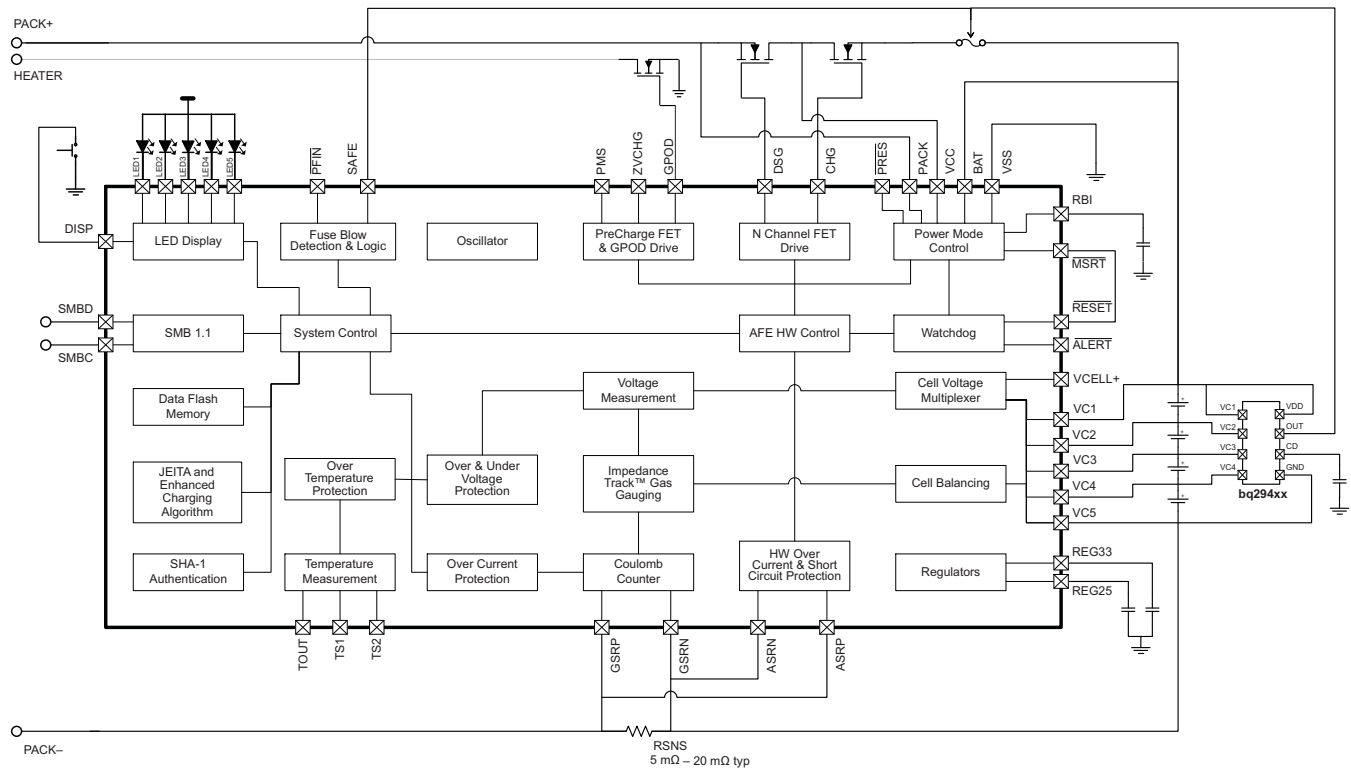

Figure 1. System Partitioning Diagram

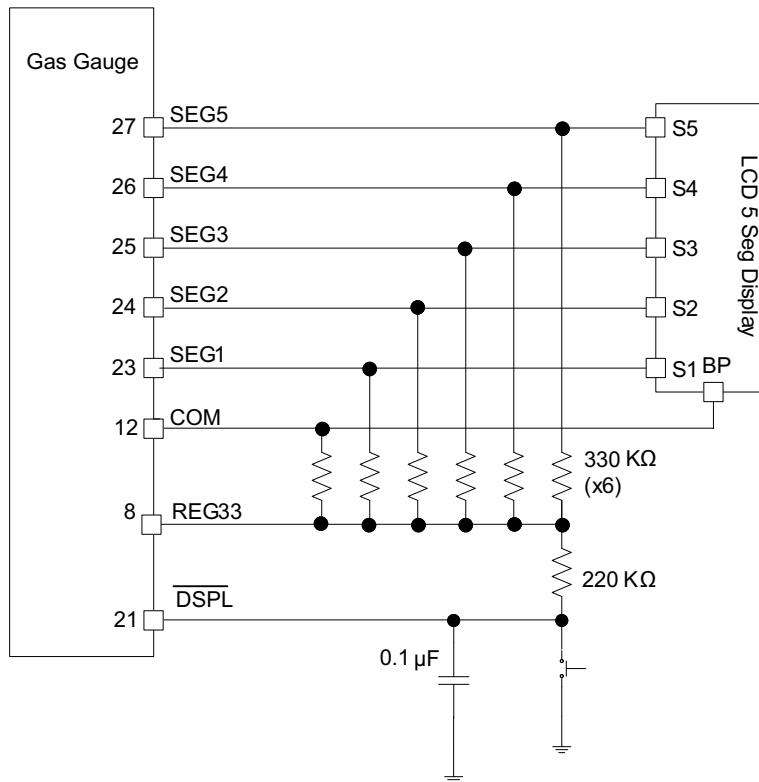
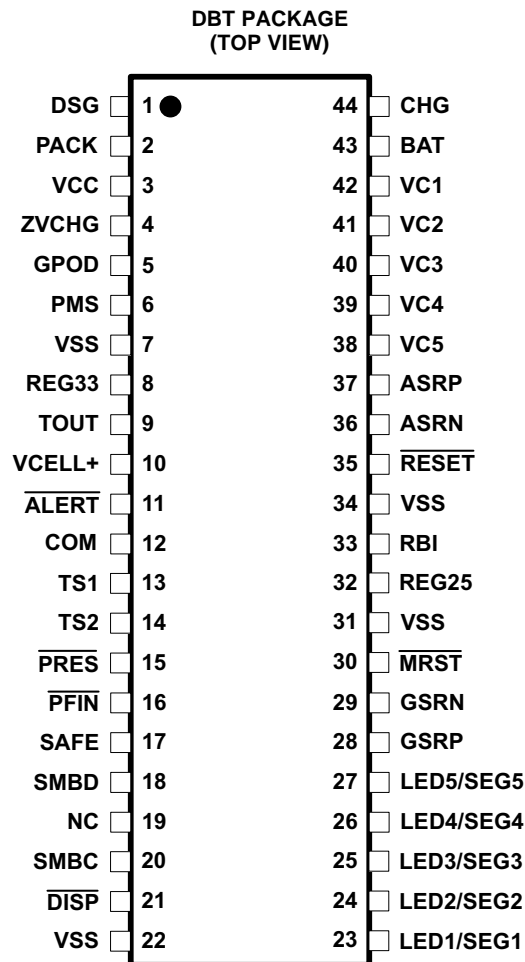

Figure 2. Typical LCD Implementation

PACKAGE PINOUT DIAGRAM

PIN FUNCTIONS

PIN		I/O ⁽¹⁾	DESCRIPTION
NO.	NAME		
1	DSG	O	High-side N-channel discharge FET gate drive
2	PACK	IA, P	Battery pack input voltage sense input. It also serves as device wake up when device is in SHUTDOWN mode.
3	VCC	P	Positive device supply input. Connect to the center connection of the CHG FET and DSG FET to ensure device supply either from battery stack or battery pack input.
4	ZVCHG	O	P-channel pre-charge FET gate drive
5	GPOD	OD	High voltage general purpose open drain output. It can be configured to be used in pre-charge condition.
6	PMS	I	PRE-CHARGE mode setting input. Connect to PACK to enable 0v pre-charge using charge FET connected at CHG pin. Connect to VSS to disable 0-V pre-charge using charge FET connected at CHG pin.
7	VSS	P	Negative supply voltage input. Connect all VSS pins together for operation of device.
8	REG33	P	3.3-V regulator output. Connect at least a 2.2- μ F capacitor to REG33 and VSS.
9	TOUT	P	Thermistor bias supply output
10	VCELL+	—	Internal cell voltage multiplexer and amplifier output. Connect a 0.1- μ F capacitor to VCELL+ and VSS.
11	ALERT	I/OD	Alert output. In case of short circuit condition, overload condition and watchdog timeout, this pin will be triggered.
12	COM	O	Output/open drain: LCD common connection

(1) I = Input, IA = Analog input, I/O = Input/output, I/OD = Input/Open-drain output, O = Output, OA = Analog output, P = Power

PIN FUNCTIONS (continued)

PIN		I/O ⁽¹⁾	DESCRIPTION
NO.	NAME		
13	TS1	IA	1 st thermistor voltage input connection to monitor temperature
14	TS2	IA	2 nd thermistor voltage input connection to monitor temperature
15	$\overline{\text{PRES}}$	I	Active low input to sense system insertion. Typically requires additional ESD protection.
16	$\overline{\text{PFIN}}$	I	Active low input to detect secondary protector status, and to allow the bq34z653 to report the status of the 2 nd -level protection input
17	SAFE	O	Active high output to enforce additional level of safety protection; e.g., fuse blow
18	SMBD	I/OD	SMBus data open-drain bidirectional pin used to transfer address and data to and from the bq34z653
19	NC	—	Not used—leave floating.
20	SMBC	I/OD	SMBus clock open-drain bidirectional pin used to clock the data transfer to and from the bq34z653
21	$\overline{\text{DISP}}$	I/OD	Display control for the LEDs. This pin is typically connected to VCC via a 100-k Ω resistor and a push button switch connected to VSS.
22	VSS	P	Negative supply voltage input. Connect all VSS pins together for operation of device.
23	LED1/SEG1	I	LED1/SEG1 display segment that drives an external LED or LCD depending on the firmware configuration
24	LED2/SEG2	I	LED2/SEG2 display segment that drives an external LED or LCD depending on the firmware configuration
25	LED3/SEG3	I	LED3/SEG3 display segment that drives an external LED or LCD depending on the firmware configuration
26	LED4/SEG4	I	LED4/SEG4 display segment that drives an external LED or LCD depending on the firmware configuration
27	LED5/SEG5	I	LED5/SEG5 display segment that drives an external LED or LCD depending on the firmware configuration
28	GSRP	IA	Coulomb counter differential input. Connect to one side of the sense resistor.
29	GSRN	IA	Coulomb counter differential input. Connect to one side of the sense resistor.
30	$\overline{\text{MRST}}$	I	Master reset input that forces the device into reset when held low. Must be held high for normal operation. Connect to RESET for correct operation of device.
31	VSS	P	Negative supply voltage input. Connect all VSS pins together for operation of device.
32	REG25	P	2.5-V regulator output. Connect at least a 1-mF capacitor to REG25 and VSS.
33	RBI	P	RAM/Register backup input. Connect a capacitor to this pin and VSS to protect loss of RAM/Register data in case of short circuit condition.
34	VSS	P	Negative supply voltage input. Connect all VSS pins together for operation of device.
35	$\overline{\text{RESET}}$	O	Reset output. Connect to $\overline{\text{MSRT}}$.
36	ASRN	IA	Short circuit and overload detection differential input. Connect to sense resistor.
37	ASRP	IA	Short circuit and overload detection differential input. Connect to sense resistor.
38	VC5	IA, P	Cell voltage sense input and cell balancing input for the negative voltage of the bottom cell in cell stack.
39	VC4	IA, P	Cell voltage sense input and cell balancing input for the positive voltage of the bottom cell and the negative voltage of the second lowest cell in cell stack.
40	VC3	IA, P	Cell voltage sense input and cell balancing input for the positive voltage of the second lowest cell in cell stack and the negative voltage of the second highest cell in 4-series cell applications.
41	VC2	IA, P	Cell voltage sense input and cell balancing input for the positive voltage of the second highest cell and the negative voltage of the highest cell in 4-series cell applications. Connect to VC3 in 2-series cell stack applications.
42	VC1	IA, P	Cell voltage sense input and cell balancing input for the positive voltage of the highest cell in cell stack in 4-series cell applications. Connect to VC2 in 3-series or 2-series cell stack applications.
43	BAT	I, P	Battery stack voltage sense input
44	CHG	O	High-side N-channel charge FET gate drive

ABSOLUTE MAXIMUM RATINGS

Over operating free-air temperature (unless otherwise noted) ⁽¹⁾

	PIN	UNIT
V _{SS} Supply voltage range	BAT, VCC	–0.3 V to 34 V
	PACK, PMS	–0.3 V to 34 V
	VC(n) – VC(n+1); n = 1, 2, 3, 4	–0.3 V to 8.5 V
	VC1, VC2, VC3, VC4	–0.3 V to 34 V
	VC5	–0.3 V to 1 V
V _{IN} Input voltage range	$\overline{\text{PFIN}}$, $\overline{\text{SMBD}}$, $\overline{\text{SMBC}}$, LED1, LED2, LED3, LED4, LED5, DISP	–0.3 V to 6 V
	TS1, TS2, SAFE, VCELL+, $\overline{\text{PRES}}$, $\overline{\text{ALERT}}$	–0.3 V to V _(REG25) + 0.3 V
	$\overline{\text{MRST}}$, GSRN, GSRP, RBI	–0.3 V to V _(REG25) + 0.3 V
	ASRN, ASRP	–1 V to 1 V
V _{OUT} Output voltage range	DSG, CHG, GPOD	–0.3 V to 34 V
	ZVCHG	–0.3 V to V _(BAT)
	TOUT, $\overline{\text{ALERT}}$, REG33	–0.3 V to 6 V
	$\overline{\text{RESET}}$	–0.3 V to 7 V
	REG25	–0.3 V to 2.75 V
I _{SS} Maximum combined sink current for input pins	$\overline{\text{PRES}}$, $\overline{\text{PFIN}}$, $\overline{\text{SMBD}}$, $\overline{\text{SMBC}}$, LED1, LED2, LED3, LED4, LED5	50 mA
T _A Operating free-air temperature range		–40°C to 85°C
T _F Functional temperature		–40°C to 100°C
T _{stg} Storage temperature range		–65°C to 150°C

- (1) Stresses beyond those listed under absolute maximum ratings may cause permanent damage to the device. These are stress ratings only, and functional operation of the device at these or any other conditions beyond those indicated under recommended operating conditions is not implied. Exposure to absolute-maximum-rated conditions for extended periods may affect device reliability.

RECOMMENDED OPERATING CONDITIONS

Over operating free-air temperature range (unless otherwise noted)

	PIN	MIN	NOM	MAX	UNIT
V _{SS} Supply voltage	VCC, BAT	4.5		25	V
V _(STARTUP) Minimum startup voltage	VCC, BAT, PACK	5.5			V
V _{IN} Input Voltage Range	VC(n) – VC(n+1); n = 1,2,3,4	0		5	V
	VC1, VC2, VC3, VC4	0		V _{SUP}	V
	VC5	0		0.5	V
	ASRN, ASRP	–0.5		0.5	V
	PACK, PMS	0		25	V
V _(GPOD) Output Voltage Range	GPOD	0		25	V
A _(GPOD) Drain Current ⁽¹⁾	GPOD			1	mA
C _(REG25) 2.5-V LDO Capacitor	REG25	1			μF
C _(REG33) 3.3-V LDO Capacitor	REG33	2.2			μF
C _(VCELL+) Cell Voltage Output Capacitor	VCELL+	0.1			μF
C _(PACK) PACK input block resistor ⁽²⁾	PACK	1			kΩ

- (1) Use an external resistor to limit the current to GPOD to 1 mA in high voltage application.
(2) Use an external resistor to limit the in-rush current PACK pin required.

ELECTRICAL CHARACTERISTICS

Over operating free-air temperature range (unless otherwise noted), $T_A = -40^\circ\text{C}$ to 85°C , $V_{(\text{REG25})} = 2.41\text{ V}$ to 2.59 V , $V_{(\text{BAT})} = 14\text{ V}$, $C_{(\text{REG25})} = 1\text{ }\mu\text{F}$, $C_{(\text{REG33})} = 2.2\text{ }\mu\text{F}$; typical values at $T_A = 25^\circ\text{C}$ (unless otherwise noted)

PARAMETER	TEST CONDITIONS	MIN	TYP	MAX	UNIT	
SUPPLY CURRENT						
$I_{(\text{NORMAL})}$	Firmware running		550		μA	
$I_{(\text{SLEEP})}$	SLEEP mode	CHG FET on; DSG FET on	124		μA	
		CHG FET off; DSG FET on	90		μA	
		CHG FET off; DSG FET off	52		μA	
$I_{(\text{SHUTDOWN})}$	SHUTDOWN mode		0.1	1	μA	
SHUTDOWN WAKE; $T_A = 25^\circ\text{C}$ (unless otherwise noted)						
$I_{(\text{PACK})}$	SHUTDOWN exit at V_{STARTUP} threshold			1	μA	
SRx WAKE FROM SLEEP; $T_A = 25^\circ\text{C}$ (unless otherwise noted)						
$V_{(\text{WAKE})}$	Positive or negative wake threshold with 1.00 mV, 2.25 mV, 4.5 mV and 9 mV programmable options		1.25	10	mV	
$V_{(\text{WAKE_ACR})}$	Accuracy of $V_{(\text{WAKE})}$	$V_{(\text{WAKE})} = 1\text{ mV};$ $I_{(\text{WAKE})} = 0, \text{RSNS1} = 0, \text{RSNS0} = 1;$	-0.7	0.7	mV	
		$V_{(\text{WAKE})} = 2.25\text{ mV};$ $I_{(\text{WAKE})} = 1, \text{RSNS1} = 0, \text{RSNS0} = 1;$ $I_{(\text{WAKE})} = 0, \text{RSNS1} = 1, \text{RSNS0} = 0;$	-0.8	0.8		
		$V_{(\text{WAKE})} = 4.5\text{ mV};$ $I_{(\text{WAKE})} = 1, \text{RSNS1} = 1, \text{RSNS0} = 1;$ $I_{(\text{WAKE})} = 0, \text{RSNS1} = 1, \text{RSNS0} = 0;$	-1.0	1.0		
		$V_{(\text{WAKE})} = 9\text{ mV};$ $I_{(\text{WAKE})} = 1, \text{RSNS1} = 1, \text{RSNS0} = 1;$	-1.4	1.4		
$V_{(\text{WAKE_TCO})}$	Temperature drift of $V_{(\text{WAKE})}$ accuracy		0.5		$\%/\text{C}$	
$t_{(\text{WAKE})}$	Time from application of current and wake of bq34z653		1	10	ms	
WATCHDOG TIMER						
t_{WDTINT}	Watchdog start up detect time		250	500	1000	ms
t_{WDWT}	Watchdog detect time		50	100	150	μs
2.5-V LDO; $I_{(\text{REG33OUT})} = 0\text{ mA}; T_A = 25^\circ\text{C}$ (unless otherwise noted)						
$V_{(\text{REG25})}$	Regulator output voltage	$4.5 < \text{VCC}$ or $\text{BAT} < 25\text{ V};$ $I_{(\text{REG25OUT})} \leq 16\text{ mA};$ $T_A = -40^\circ\text{C}$ to 100°C	2.41	2.5	2.59	V
$\Delta V_{(\text{REG25TEMP})}$	Regulator output change with temperature	$I_{(\text{REG25OUT})} = 2\text{ mA};$ $T_A = -40^\circ\text{C}$ to 100°C		± 0.2		%
$\Delta V_{(\text{REG25LINE})}$	Line regulation	$5.4 < \text{VCC}$ or $\text{BAT} < 25\text{ V};$ $I_{(\text{REG25OUT})} = 2\text{ mA}$		3	10	mV
$\Delta V_{(\text{REG25LOAD})}$	Load Regulation	$0.2\text{ mA} \leq I_{(\text{REG25OUT})} \leq 2\text{ mA}$		7	25	mV
		$0.2\text{ mA} \leq I_{(\text{REG25OUT})} \leq 16\text{ mA}$		25	50	
$I_{(\text{REG25MAX})}$	Current Limit	Drawing current until REG25 = 2 V to 0 V	5	40	75	mA
3.3-V LDO; $I_{(\text{REG25OUT})} = 0\text{ mA}; T_A = 25^\circ\text{C}$ (unless otherwise noted)						
$V_{(\text{REG33})}$	Regulator output voltage	$4.5 < \text{VCC}$ or $\text{BAT} < 25\text{ V};$ $I_{(\text{REG33OUT})} \leq 25\text{ mA};$ $T_A = -40^\circ\text{C}$ to 100°C	3	3.3	3.6	V
$\Delta V_{(\text{REG33TEMP})}$	Regulator output change with temperature	$I_{(\text{REG33OUT})} = 2\text{ mA};$ $T_A = -40^\circ\text{C}$ to 100°C		± 0.2		%
$\Delta V_{(\text{REG33LINE})}$	Line regulation	$5.4 < \text{VCC}$ or $\text{BAT} < 25\text{ V};$ $I_{(\text{REG33OUT})} = 2\text{ mA}$		3	10	mV
$\Delta V_{(\text{REG33LOAD})}$	Load Regulation	$0.2\text{ mA} \leq I_{(\text{REG33OUT})} \leq 2\text{ mA}$		7	17	mV
		$0.2\text{ mA} \leq I_{(\text{REG33OUT})} \leq 25\text{ mA}$		40	100	
$I_{(\text{REG33MAX})}$	Current Limit	Drawing current until REG33 = 3 V	25	100	145	mA
		Short REG33 to VSS, REG33 = 0 V	12		65	
THERMISTOR DRIVE						
$V_{(\text{TOUT})}$	Output voltage	$I_{(\text{TOUT})} = 0\text{ mA}; T_A = 25^\circ\text{C}$		$V_{(\text{REG25})}$		V

ELECTRICAL CHARACTERISTICS (continued)

Over operating free-air temperature range (unless otherwise noted), $T_A = -40^\circ\text{C}$ to 85°C , $V_{(\text{REG25})} = 2.41\text{ V}$ to 2.59 V , $V_{(\text{BAT})} = 14\text{ V}$, $C_{(\text{REG25})} = 1\ \mu\text{F}$, $C_{(\text{REG33})} = 2.2\ \mu\text{F}$; typical values at $T_A = 25^\circ\text{C}$ (unless otherwise noted)

PARAMETER		TEST CONDITIONS	MIN	TYP	MAX	UNIT
$R_{\text{DS(on)}}$	TOUT pass element resistance	$I_{(\text{TOUT})} = 1\ \text{mA}$; $R_{\text{DS(on)}} = (V_{(\text{REG25})} - V_{(\text{TOUT})}) / 1\ \text{mA}$; $T_A = -40^\circ\text{C}$ to 100°C		50	100	Ω
LED OR LCD OUTPUTS						
V_{OL}	Output low voltage	LED1, LED2, LED3, LED4, LED5			0.4	V
VCELL+ HIGH VOLTAGE TRANSLATION						
$V_{(\text{VCELL+OUT})}$	Translation output	$\text{VC}(n) - \text{VC}(n+1) = 0\ \text{V}$; $T_A = -40^\circ\text{C}$ to 100°C	0.950	0.975	1	V
$V_{(\text{VCELL+REF})}$		$\text{VC}(n) - \text{VC}(n+1) = 4.5\ \text{V}$; $T_A = -40^\circ\text{C}$ to 100°C	0.275	0.3	0.375	
$V_{(\text{VCELL+PACK})}$		Internal AFE reference voltage; $T_A = -40^\circ\text{C}$ to 100°C	0.965	0.975	0.985	
$V_{(\text{VCELL+BAT})}$		Voltage at PACK pin; $T_A = -40^\circ\text{C}$ to 100°C	$0.98 \times V_{(\text{PACK})}/18$	$V_{(\text{PACK})}/18$	$1.02 \times V_{(\text{PACK})}/18$	
		Voltage at BAT pin; $T_A = -40^\circ\text{C}$ to 100°C	$0.98 \times V_{(\text{BAT})}/18$	$V_{(\text{BAT})}/18$	$1.02 \times V_{(\text{BAT})}/18$	
CMMR	Common mode rejection ratio	VCELL+	40			dB
K	Cell scale factor	$K = (\text{VCELL+ output } (\text{VC5}=0\ \text{V}; \text{VC4}=4.5\ \text{V}) - \text{VCELL+ output } (\text{VC5}=0\ \text{V}; \text{VC4}=0\ \text{V})) / 4.5$	0.147	0.150	0.153	
		$K = (\text{VCELL+ output } (\text{VC2}=13.5\ \text{V}; \text{VC1}=18\ \text{V}) - \text{VCELL+ output } (\text{VC5}=13.5\ \text{V}; \text{VC1}=13.5\ \text{V})) / 4.5$	0.147	0.150	0.153	
$I_{(\text{VCELL+OUT})}$	Drive Current to VCELL+ capacitor	$\text{VC}(n) - \text{VC}(n+1) = 0\ \text{V}$; $\text{VCELL+} = 0\ \text{V}$; $T_A = -40^\circ\text{C}$ to 100°C	12	18		μA
$V_{(\text{VCELL+O})}$	CELL offset error	CELL output ($\text{VC2} = \text{VC1} = 18\ \text{V}$) – CELL output ($\text{VC2} = \text{VC1} = 0\ \text{V}$)	-18	-1	18	mV
I_{VChL}	VC(n) pin leakage current	VC1, VC2, VC3, VC4, VC5 = 3 V	-1	0.01	1	μA
CELL BALANCING						
R_{BAL}	Internal cell balancing FET resistance	$R_{\text{DS(on)}}$ for internal FET switch at $V_{\text{DS}} = 2\ \text{V}$; $T_A = 25^\circ\text{C}$	200	400	600	Ω
HARDWARE SHORT CIRCUIT AND OVERLOAD PROTECTION; $T_A = 25^\circ\text{C}$ (unless otherwise noted)						
$V_{(\text{OL})}$	OL detection threshold voltage accuracy	$V_{\text{OL}} = 25\ \text{mV}$ (min)	15	25	35	mV
		$V_{\text{OL}} = 100\ \text{mV}$; $\text{RSNS} = 0, 1$	90	100	110	
		$V_{\text{OL}} = 205\ \text{mV}$ (max)	185	205	225	
$V_{(\text{SCC})}$	SCC detection threshold voltage accuracy	$V_{(\text{SCC})} = 50\ \text{mV}$ (min)	30	50	70	mV
		$V_{(\text{SCC})} = 200\ \text{mV}$; $\text{RSNS} = 0, 1$	180	200	220	
		$V_{(\text{SCC})} = 475\ \text{mV}$ (max)	428	475	523	
$V_{(\text{SCD})}$	SCD detection threshold voltage accuracy	$V_{(\text{SCD})} = -50\ \text{mV}$ (min)	-30	-50	-70	mV
		$V_{(\text{SCD})} = -200\ \text{mV}$; $\text{RSNS} = 0, 1$	-180	-200	-220	
		$V_{(\text{SCD})} = -475\ \text{mV}$ (max)	-428	-475	-523	
t_{da}	Delay time accuracy			± 15.25		μs
t_{pd}	Protection circuit propagation delay			50		μs
FET DRIVE CIRCUIT; $T_A = 25^\circ\text{C}$ (unless otherwise noted)						
$V_{(\text{DSGON})}$	DSG pin output on voltage	$V_{(\text{DSGON})} = V_{(\text{DSG})} - V_{(\text{PACK})}$; $V_{(\text{GS})} = 10\ \text{M}\Omega$; DSG and CHG on; $T_A = -40^\circ\text{C}$ to 100°C	8	12	16	V
$V_{(\text{CHGON})}$	CHG pin output on voltage	$V_{(\text{CHGON})} = V_{(\text{CHG})} - V_{(\text{BAT})}$; $V_{(\text{GS})} = 10\ \text{M}\Omega$; DSG and CHG on; $T_A = -40^\circ\text{C}$ to 100°C	8	12	16	V
$V_{(\text{DSGOFF})}$	DSG pin output off voltage	$V_{(\text{DSGOFF})} = V_{(\text{DSG})} - V_{(\text{PACK})}$			0.2	V
$V_{(\text{CHGOFF})}$	CHG pin output off voltage	$V_{(\text{CHGOFF})} = V_{(\text{CHG})} - V_{(\text{BAT})}$			0.2	V
t_r	Rise time	$C_L = 4700\ \text{pF}$; $V_{(\text{PACK})} \leq \text{DSG} \leq V_{(\text{PACK})} + 4\ \text{V}$		400	1000	μs
		$C_L = 4700\ \text{pF}$; $V_{(\text{BAT})} \leq \text{CHG} \leq V_{(\text{BAT})} + 4\ \text{V}$		400	1000	

ELECTRICAL CHARACTERISTICS (continued)

Over operating free-air temperature range (unless otherwise noted), $T_A = -40^\circ\text{C}$ to 85°C , $V_{(\text{REG25})} = 2.41\text{ V}$ to 2.59 V , $V_{(\text{BAT})} = 14\text{ V}$, $C_{(\text{REG25})} = 1\text{ }\mu\text{F}$, $C_{(\text{REG33})} = 2.2\text{ }\mu\text{F}$; typical values at $T_A = 25^\circ\text{C}$ (unless otherwise noted)

PARAMETER	TEST CONDITIONS	MIN	TYP	MAX	UNIT
t_f Fall time	$C_L = 4700\text{ pF}$; $V_{(\text{PACK})} + V_{(\text{DSGON})} \leq \text{DSG} \leq V_{(\text{PACK})} + 1\text{ V}$		40	200	μs
	$C_L = 4700\text{ pF}$; $V_{(\text{BAT})} + V_{(\text{CHGON})} \leq \text{CHG} \leq V_{(\text{BAT})} + 1\text{ V}$		40	200	
$V_{(\text{ZVCHG})}$ ZVCHG clamp voltage	BAT = 4.5 V	3.3	3.5	3.7	V
LOGIC; $T_A = -40^\circ\text{C}$ to 100°C (unless otherwise noted)					
$R_{(\text{PULLUP})}$ Internal pullup resistance	$\overline{\text{ALERT}}$	60	100	200	k Ω
	$\overline{\text{RESET}}$	1	3	6	
V_{OL} Logic low output voltage level	$\overline{\text{ALERT}}$			0.2	V
	$\overline{\text{RESET}}$; $V_{(\text{BAT})} = 7\text{ V}$; $V_{(\text{REG25})} = 1.5\text{ V}$; $I_{(\text{RESET})} = 200\text{ }\mu\text{A}$			0.4	
	GPOD; $I_{(\text{GPOD})} = 50\text{ }\mu\text{A}$			0.6	
LOGIC SMBC, SMBD, PFIN, PRES, SAFE, ALERT, DISP, COM					
V_{IH} High-level input voltage		2.0			V
V_{IL} Low-level input voltage				0.8	V
V_{OH} Output voltage high ⁽¹⁾	$I_L = -0.5\text{ mA}$	$V_{\text{REG25}} - 0.5$			V
V_{OL} Low-level output voltage	$\overline{\text{PRES}}, \overline{\text{PFIN}}, \overline{\text{ALERT}}, \overline{\text{DISP}}$; $I_L = 7\text{ mA}$;			0.4	V
C_I Input capacitance			5		pF
$I_{(\text{SAFE})}$ SAFE source currents	SAFE active, $\text{SAFE} = V_{(\text{REG25})} - 0.6\text{ V}$	-3			mA
$I_{\text{kg}(\text{SAFE})}$ SAFE leakage current	SAFE inactive	-0.2		0.2	μA
I_{kg} Input leakage current				1	μA
ADC⁽²⁾					
Input voltage range	TS1, TS2, using Internal V_{ref}	-0.2		1	V
Conversion time			31.5		ms
Resolution (no missing codes)		16			bits
Effective resolution		14	15		bits
Integral nonlinearity				± 0.03	%FSR ⁽³⁾
Offset error ⁽⁴⁾			140	250	μV
Offset error drift ⁽⁴⁾	$T_A = 25^\circ\text{C}$ to 85°C		2.5	18	$\mu\text{V}/^\circ\text{C}$
Full-scale error ⁽⁵⁾			$\pm 0.1\%$	$\pm 0.7\%$	
Full-scale error drift			50		PPM/ $^\circ\text{C}$
Effective input resistance ⁽⁶⁾		8			M Ω
COULOMB COUNTER					
Input voltage range		-0.20		0.20	V
Conversion time	Single conversion		250		ms
Effective resolution	Single conversion	15			bits
Integral nonlinearity	-0.1 V to 0.20 V		± 0.007	± 0.034	%FSR
	-0.20 V to -0.1 V		± 0.007		
Offset error ⁽⁷⁾	$T_A = 25^\circ\text{C}$ to 85°C		10		μV
Offset error drift			0.4	0.7	$\mu\text{V}/^\circ\text{C}$
Full-scale error ⁽⁸⁾ ⁽⁹⁾			$\pm 0.35\%$		
Full-scale error drift			150		PPM/ $^\circ\text{C}$

(1) RC[0:7] bus

(2) Unless otherwise specified, the specification limits are valid at all measurement speed modes.

(3) Full-scale reference

(4) Post-calibration performance and no I/O changes during conversion with SRN as the ground reference

(5) Uncalibrated performance. This gain error can be eliminated with external calibration.

(6) The A/D input is a switched-capacitor input. Since the input is switched, the effective input resistance is a measure of the average resistance.

(7) Post-calibration performance

(8) Reference voltage for the coulomb counter is typically $V_{\text{ref}}/3.969$ at $V_{(\text{REG25})} = 2.5\text{ V}$, $T_A = 25^\circ\text{C}$.

(9) Uncalibrated performance. This gain error can be eliminated with external calibration.

ELECTRICAL CHARACTERISTICS (continued)

Over operating free-air temperature range (unless otherwise noted), $T_A = -40^{\circ}\text{C}$ to 85°C , $V_{(\text{REG25})} = 2.41\text{ V}$ to 2.59 V , $V_{(\text{BAT})} = 14\text{ V}$, $C_{(\text{REG25})} = 1\text{ }\mu\text{F}$, $C_{(\text{REG33})} = 2.2\text{ }\mu\text{F}$; typical values at $T_A = 25^{\circ}\text{C}$ (unless otherwise noted)

PARAMETER	TEST CONDITIONS	MIN	TYP	MAX	UNIT
Effective input resistance ⁽¹⁰⁾	$T_A = 25^{\circ}\text{C}$ to 85°C	2.5			$\text{M}\Omega$
INTERNAL TEMPERATURE SENSOR					
$V_{(\text{TEMP})}$ Temperature sensor voltage ⁽¹¹⁾			-2.0		$\text{mV}/^{\circ}\text{C}$
VOLTAGE REFERENCE					
Output voltage		1.215	1.225	1.230	V
Output voltage drift			65		$\text{PPM}/^{\circ}\text{C}$
HIGH FREQUENCY OSCILLATOR					
$f_{(\text{OSC})}$ Operating frequency			4.194		MHz
$f_{(\text{EIO})}$ Frequency error ⁽¹²⁾ ⁽¹³⁾		-3%	0.25%	3%	
	$T_A = 20^{\circ}\text{C}$ to 70°C	-2%	0.25%	2%	
$t_{(\text{SXO})}$ Start-up time ⁽¹⁴⁾			2.5	5	ms
LOW FREQUENCY OSCILLATOR					
$f_{(\text{LOSC})}$ Operating frequency			32.768		kHz
$f_{(\text{LEIO})}$ Frequency error ⁽¹³⁾ ⁽¹⁵⁾		-2.5%	0.25%	2.5%	
	$T_A = 20^{\circ}\text{C}$ to 70°C	-1.5%	0.25%	1.5%	
$t_{(\text{LSXO})}$ Start-up time ⁽¹⁴⁾				500	μs

(10) The CC input is a switched capacitor input. Since the input is switched, the effective input resistance is a measure of the average resistance.

(11) $-53.7\text{ LSB}/^{\circ}\text{C}$

(12) The frequency error is measured from 4.194 MHz.

(13) The frequency drift is included and measured from the trimmed frequency at $V_{(\text{REG25})} = 2.5\text{ V}$, $T_A = 25^{\circ}\text{C}$.

(14) The startup time is defined as the time it takes for the oscillator output frequency to be $\pm 3\%$.

(15) The frequency error is measured from 32.768 kHz.

POWER-ON RESET

Over operating free-air temperature range (unless otherwise noted), $T_A = -40^{\circ}\text{C}$ to 85°C , $V_{(\text{REG25})} = 2.41\text{ V}$ to 2.59 V , $V_{(\text{BAT})} = 14\text{ V}$, $C_{(\text{REG25})} = 1\text{ }\mu\text{F}$, $C_{(\text{REG33})} = 2.2\text{ }\mu\text{F}$; typical values at $T_A = 25^{\circ}\text{C}$ (unless otherwise noted)

PARAMETER	TEST CONDITIONS	MIN	TYP	MAX	UNIT
$V_{\text{IT-}}$ Negative-going voltage input		1.7	1.8	1.9	V
VHYS Power-on reset hysteresis		5	125	200	mV
t_{RST} $\overline{\text{RESET}}$ active low time	Active low time after power up or watchdog reset	100	250	560	μs

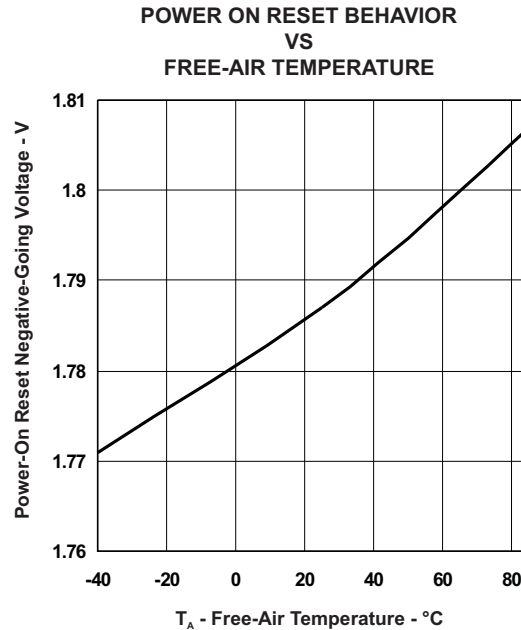

DATA FLASH CHARACTERISTICS OVER RECOMMENDED OPERATING TEMPERATURE AND SUPPLY VOLTAGE

Typical values at T_A = 25°C and V_(REG25) = 2.5 V (unless otherwise noted)

PARAMETER	TEST CONDITIONS	MIN	TYP	MAX	UNIT
Data retention	See ⁽¹⁾	10			Years
Flash programming write-cycles		20k			Cycles
t _(ROWPROG) Row programming time				2	ms
t _(MASSERASE) Mass-erase time				200	ms
t _(PAGEERASE) Page-erase time				20	ms
I _(DDPROG) Flash-write supply current				5	10
I _(DDERASE) Flash-erase supply current			5	10	mA
RAM/REGISTER BACKUP					
I _(RB) RB data-retention input current	V _(RBI) > V _{(RBI)MIN} , V _{REG25} < V _{IT-} , T _A = 85°C		1000	2500	nA
	V _(RBI) > V _{(RBI)MIN} , V _{REG25} < V _{IT-} , T _A = 25°C		90	220	
V _(RB) RB data-retention input voltage ⁽²⁾		1.7			V

(1) Specified by design. Not production tested.

(2) Specified by design. Not production tested.

SMBus TIMING CHARACTERISTICS

T_A = -40°C to 85°C Typical Values at T_A = 25°C and V_{REG25} = 2.5 V (Unless Otherwise Noted)

PARAMETER	TEST CONDITIONS	MIN	TYP	MAX	UNIT
f _(SMB) SMBus operating frequency	SLAVE mode, SMBC 50% duty cycle	10		100	kHz
f _(MAS) SMBus master clock frequency	MASTER mode, No clock low slave extend		51.2		kHz
t _(BUF) Bus free time between start and stop (See Figure 3.)		4.7			µs
t _(HD:STA) Hold time after (repeated) start (See Figure 3.)		4			µs
t _(SU:STA) Repeated start setup time (See Figure 3.)		4.7			µs
t _(SU:STO) Stop setup time (See Figure 3.)		4			µs
t _(HD:DAT) Data hold time (See Figure 3.)	RECEIVE mode	0			ns
	TRANSMIT mode	300			

SMBus TIMING CHARACTERISTICS (continued)

$T_A = -40^{\circ}\text{C}$ to 85°C Typical Values at $T_A = 25^{\circ}\text{C}$ and $V_{\text{REG25}} = 2.5\text{ V}$ (Unless Otherwise Noted)

PARAMETER		TEST CONDITIONS	MIN	TYP	MAX	UNIT
$t_{\text{(SU:DAT)}}$	Data setup time (See Figure 3.)		250			ns
$t_{\text{(TIMEOUT)}}$	Error signal/detect (See Figure 3.)	See (1)	25		35	μs
$t_{\text{(LOW)}}$	Clock low period (See Figure 3.)		4.7			μs
$t_{\text{(HIGH)}}$	Clock high period (See Figure 3.)	See (2)	4		50	μs
$t_{\text{(LOW:SEXT)}}$	Cumulative clock low slave extend time	See (3)			25	ms
$t_{\text{(LOW:MEXT)}}$	Cumulative clock low master extend time (See Figure 3.)	See (4)			10	ms
t_f	Clock/data fall time	See (5)			300	ns
t_r	Clock/data rise time	See (6)			1000	ns

- (1) The bq34z653 times out when any clock low exceeds $t_{\text{(TIMEOUT)}}$.
- (2) $t_{\text{(HIGH)}}$, Max, is the minimum bus idle time. $\text{SMBC} = \text{SMBD} = 1$ for $t > 50\text{ ms}$ causes reset of any transaction involving bq34z653 that is in progress. This specification is valid when the NC_SMB control bit remains in the default cleared state ($\text{CLK}[0]=0$).
- (3) $t_{\text{(LOW:SEXT)}}$ is the cumulative time a slave device is allowed to extend the clock cycles in one message from initial start to the stop.
- (4) $t_{\text{(LOW:MEXT)}}$ is the cumulative time a master device is allowed to extend the clock cycles in one message from initial start to the stop.
- (5) Rise time $t_r = \text{VILMAX} - 0.15$ to $(\text{VIHMIN} + 0.15)$
- (6) Fall time $t_f = 0.9V_{\text{DD}}$ to $(\text{VILMAX} - 0.15)$

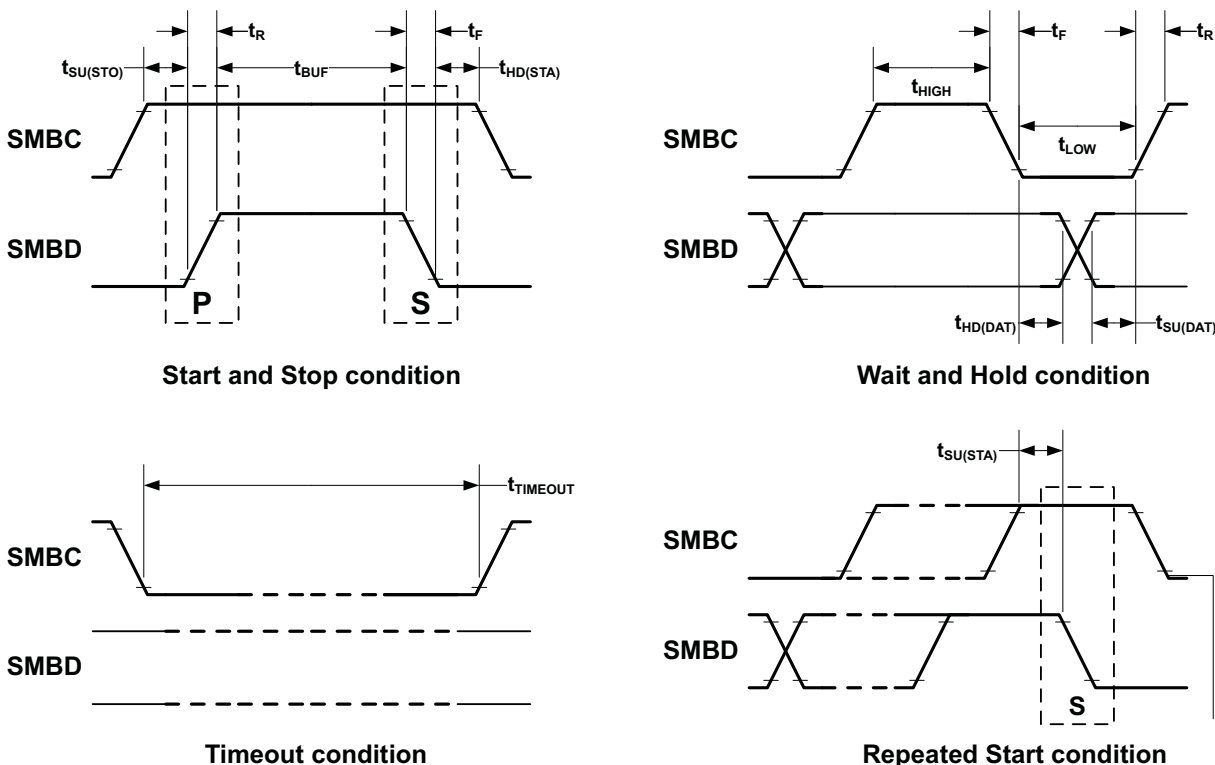

A. SCLKACK is the acknowledge-related clock pulse generated by the master.

Figure 3. SMBus Timing Diagram

FEATURE SET

Primary (1st Level) Safety Features

The bq34z653 supports a wide range of battery and system protection features that can be easily configured. The primary safety features include:

- Cell over/undervoltage protection
- Charge and discharge overcurrent
- Short circuit protection
- Charge and discharge overtemperature with independent alarms and thresholds for each thermistor
- AFE Watchdog

Secondary (2nd Level) Safety Features

The secondary safety features of the bq34z653 can be used to indicate more serious faults via the SAFE pin. This pin can be used to blow an in-line fuse to permanently disable the battery pack from charging or discharging. The secondary safety protection features include:

- Safety overvoltage
- Safety undervoltage
- 2nd-level protection IC input
- Safety overcurrent in charge and discharge
- Safety over-temperature in charge and discharge with independent alarms and thresholds for each thermistor
- Charge FET and zero-volt charge FET fault
- Discharge FET fault
- Cell imbalance detection (active and at rest)
- Open thermistor detection
- Fuse blow detection
- AFE communication fault

Charge Control Features

The bq34z653 charge control features include:

- Supports JEITA temperature ranges. Reports charging voltage and charging current according to the active temperature range
- Handles more complex charging profiles. Allows for splitting the standard temperature range into two sub-ranges, and for varying the charging current according to the cell voltage
- Reports the appropriate charging current needed for constant current charging and the appropriate charging voltage needed for constant voltage charging to a smart charger using SMBus broadcasts
- Determines the chemical state of charge of each battery cell using Impedance Track, and can reduce the charge difference of the battery cells in a fully charged state of the battery pack, gradually using the cell balancing algorithm during charging. This prevents fully charged cells from overcharging and causing excessive degradation and also increases the usable pack energy by preventing premature charge termination.
- Supports pre-charging/zero-volt charging
- Supports charge inhibit and charge suspend if battery pack temperature is out of temperature range
- Reports charging fault and also indicate charge status via charge and discharge alarms
- Battery heater control to allow battery charging in low ambient temperatures

Gas Gauging

The bq34z653 uses the Impedance Track Technology to measure and calculate the available charge in battery cells. The achievable accuracy is better than 1% error over the lifetime of the battery and there is no full charge discharge learning cycle required.

See *Theory and Implementation of Impedance Track Battery Fuel-Gauging Algorithm* application note ([SLUA364](#)) for further details.

Lifetime Data Logging Features

The bq34z653 offers lifetime data logging, where important measurements are stored for warranty and analysis purposes. The data monitored include:

- Lifetime maximum temperature
- Lifetime maximum temperature count
- Lifetime maximum temperature duration
- Lifetime minimum temperature
- Lifetime maximum battery cell voltage
- Lifetime maximum battery cell voltage count
- Lifetime maximum battery cell voltage duration
- Lifetime minimum battery cell voltage
- Lifetime maximum battery pack voltage
- Lifetime minimum battery pack voltage
- Lifetime maximum charge current
- Lifetime maximum discharge current
- Lifetime maximum charge power
- Lifetime maximum discharge power
- Lifetime maximum average discharge current
- Lifetime maximum average discharge power
- Lifetime average temperature

Authentication

The bq34z653 supports authentication by the host using SHA-1.

Power Modes

The bq34z653 supports three different power modes to reduce power consumption:

- In NORMAL mode, the bq34z653 performs measurements, calculations, protection decisions and data updates in 1-second intervals. Between these intervals, the bq34z653 is in a reduced power stage.
- In SLEEP mode, the bq34z653 performs measurements, calculations, protection decisions, and data updates in adjustable time intervals. Between these intervals, the bq34z653 is in a reduced power stage. The bq34z653 has a wake function that enables exit from SLEEP mode when current flow or failure is detected.
- In SHUTDOWN mode, the bq34z653 is completely disabled.

CONFIGURATION

Oscillator Function

The bq34z653 fully integrates the system oscillators; therefore, no external components are required for this feature.

System Present Operation

The bq34z653 periodically verifies the $\overline{\text{PRES}}$ pin and detects that the battery is present in the system via a low state on a PRES input. When this occurs, the bq34z653 enters NORMAL operating mode. When the pack is removed from the system and the PRES input is high, the bq34z653 enters the battery-removed state, disabling the charge, discharge, and ZVCHG FETs. The PRES input is ignored and can be left floating when non-removal mode is set in the data flash.

BATTERY PARAMETER MEASUREMENTS

The bq34z653 uses an integrating delta-sigma analog-to-digital converter (ADC) for current measurement, and a second delta-sigma ADC for individual cell and battery voltage and temperature measurement.

Charge and Discharge Counting

The integrating delta-sigma ADC measures the charge/discharge flow of the battery by measuring the voltage drop across a small-value sense resistor between the SR1 and SR2 pins. The integrating ADC measures bipolar signals from -0.25 V to 0.25 V . The bq34z653 detects charge activity when $V_{\text{SR}} = V_{(\text{SRP})} - V_{(\text{SRN})}$ is positive, and discharge activity when $V_{\text{SR}} = V_{(\text{SRP})} - V_{(\text{SRN})}$ is negative. The bq34z653 continuously integrates the signal over time using an internal counter. The fundamental rate of the counter is 0.65 nVh .

Voltage

The bq34z653 updates the individual series cell voltages at one second intervals. The internal ADC of the bq34z653 measures the voltage, and scales and calibrates it appropriately. This data is also used to calculate the impedance of the cell for the Impedance Track gas-gauging.

Current

The bq34z653 uses the SRP and SRN inputs to measure and calculate the battery charge and discharge current using a $5\text{-m}\Omega$ to $20\text{-m}\Omega$ typ. sense resistor.

Wake Function

The bq34z653 can exit SLEEP mode, if enabled, by the presence of a programmable level of current signal across SRP and SRN.

Auto Calibration

The bq34z653 provides an auto-calibration feature to cancel the voltage offset error across SRN and SRP for maximum charge measurement accuracy. The bq34z653 performs auto-calibration when the SMBus lines stay low continuously for a minimum of a programmable amount of time.

Temperature

The bq34z653 has an internal temperature sensor and two external temperature sensor inputs, TS1 and TS2, used in conjunction with two identical NTC thermistors (default is Semitec 103AT) to sense the battery environmental temperature. The bq34z653 can be configured to use the internal temperature sensor or up to two external temperature sensors.

COMMUNICATIONS

The bq34z653 uses SMBus v1.1 with MASTER mode and packet error checking (PEC) options per the SBS specification.

SMBus On and Off State

The bq34z653 detects an SMBus off state when SMBC and SMBD are logic-low for ≥ 2 s. Clearing this state requires either SMBC or SMBD to transition high. Within 1 ms, the communication bus is available.

SBS Commands

Table 2. SBS COMMANDS

SBS Cmd	Mode	Name	Format	Size in Bytes	Min Value	Max Value	Default Value	Unit
0x00	R/W	ManufacturerAccess	Hex	2	0x0000	0xffff	—	—
0x01	R/W	RemainingCapacityAlarm	Integer	2	0	700 or 1000	300 or 432	mAh or 10 mWh
0x02	R/W	RemainingTimeAlarm	Unsigned integer	2	0	30	10	min
0x03	R/W	BatteryMode	Hex	2	0x0000	0xffff	—	—
0x04	R/W	AtRate	Integer	2	-32,768	32,767	—	mA or 10 mW
0x05	R	AtRateTimeToFull	Unsigned integer	2	0	65,535	—	min
0x06	R	AtRateTimeToEmpty	Unsigned integer	2	0	65,535	—	min
0x07	R	AtRateOK	Unsigned integer	2	0	65,535	—	—
0x08	R	Temperature	Unsigned integer	2	0	65,535	—	0.1°K
0x09	R	Voltage	Unsigned integer	2	0	20,000	—	mV
0x0a	R	Current	Integer	2	-32,768	32,767	—	mA
0x0b	R	AverageCurrent	Integer	2	-32,768	32,767	—	mA
0x0c	R	MaxError	Unsigned integer	1	0	100	—	%
0x0d	R	RelativeStateOfCharge	Unsigned integer	1	0	100	—	%
0x0e	R	AbsoluteStateOfCharge	Unsigned integer	1	0	100+	—	%
0x0f	R/W	RemainingCapacity	Unsigned integer	2	0	65,535	—	mAh or 10 mWh
0x10	R	FullChargeCapacity	Unsigned integer	2	0	65,535	—	mAh or 10 mWh
0x11	R	RunTimeToEmpty	Unsigned integer	2	0	65,534	—	min
0x12	R	AverageTimeToEmpty	Unsigned integer	2	0	65,534	—	min
0x13	R	AverageTimeToFull	Unsigned integer	2	0	65,534	—	min
0x14	R	ChargingCurrent	Unsigned integer	2	0	65,534	—	mA
0x15	R	ChargingVoltage	Unsigned integer	2	0	65,534	—	mV
0x16	R	BatteryStatus	Hex	2	0x0000	0xdbff	—	—
0x17	R/W	CycleCount	Unsigned integer	2	0	65,535	0	—
0x18	R/W	DesignCapacity	Integer	2	0	32,767	4400 or 6336	mAh or 10 mWh
0x19	R/W	DesignVoltage	Integer	2	7000	18,000	14,400	mV

Table 2. SBS COMMANDS (continued)

SBS Cmd	Mode	Name	Format	Size in Bytes	Min Value	Max Value	Default Value	Unit
0x1a	R/W	SpecificationInfo	Hex	2	0x0000	0xffff	0x0031	—
0x1b	R/W	ManufactureDate	Unsigned integer	2	0	65,535	0	—
0x1c	R/W	SerialNumber	Hex	2	0x0000	0xffff	0x0000	—
0x20	R/W	ManufacturerName	String	20+1	—	—	Texas Instruments	—
0x21	R/W	DeviceName	String	20+1	—	—	bq34z653	—
0x22	R/W	DeviceChemistry	String	4+1	—	—	LION	—
0x23	R	ManufacturerData	String	14+1	—	—	—	—
0x2f	R/W	Authenticate	String	20+1	—	—	—	—
0x3c	R	CellVoltage4	Unsigned integer	2	0	65,535	—	mV
0x3d	R	CellVoltage3	Unsigned integer	2	0	65,535	—	mV
0x3e	R	CellVoltage2	Unsigned integer	2	0	65,535	—	mV
0x3f	R	CellVoltage1	Unsigned integer	2	0	65,535	—	mV

Table 3. EXTENDED SBS COMMANDS

SBS Cmd	Mode	Name	Format	Size in Bytes	Min Value	Max Value	Default Value	Unit
0x45	R	AFEData	String	11+1	—	—	—	—
0x46	R/W	FETControl	Hex	2	0x00	0xff	—	—
0x4f	R	StateOfHealth	Hex	2	0x0000	0xffff	—	%
0x51	R	SafetyStatus	Hex	2	0x0000	0xffff	—	—
0x52	R	PFAAlert	Hex	2	0x0000	0xffff	—	—
0x53	R	PFStatus	Hex	2	0x0000	0xffff	—	—
0x54	R	OperationStatus	Hex	2	0x0000	0xffff	—	—
0x55	R	ChargingStatus	Hex	2	0x0000	0xffff	—	—
0x57	R	ResetData	Hex	2	0x0000	0xffff	—	—
0x58	R	WDRResetData	Unsigned integer	2	0	65,535	—	—
0x5a	R	PackVoltage	Unsigned integer	2	0	65,535	—	mV
0x5d	R	AverageVoltage	Unsigned integer	2	0	65,535	—	mV
0x5e	R	TS1Temperature	Integer	2	–400	1200	—	0.1°C
0x5f	R	TS2Temperature	Integer	2	–400	1200	—	0.1°C
0x60	R/W	UnSealKey	Hex	4	0x00000000	0xffffffff	—	—
0x61	R/W	FullAccessKey	Hex	4	0x00000000	0xffffffff	—	—
0x62	R/W	PFKey	Hex	4	0x00000000	0xffffffff	—	—
0x63	R/W	AuthenKey3	Hex	4	0x00000000	0xffffffff	—	—
0x64	R/W	AuthenKey2	Hex	4	0x00000000	0xffffffff	—	—
0x65	R/W	AuthenKey1	Hex	4	0x00000000	0xffffffff	—	—
0x66	R/W	AuthenKey0	Hex	4	0x00000000	0xffffffff	—	—
0x68	R	SafetyAlert2	Hex	2	0x0000	0x000f	—	—
0x69	R	SafetyStatus2	Hex	2	0x0000	0x000f	—	—
0x6a	R	PFAAlert2	Hex	2	0x0000	0x000f	—	—
0x6b	R	PFStatus2	Hex	2	0x0000	0x000f	—	—

Table 3. EXTENDED SBS COMMANDS (continued)

SBS Cmd	Mode	Name	Format	Size in Bytes	Min Value	Max Value	Default Value	Unit
0x6c	R	ManufBlock1	String	20	—	—	—	—
0x6d	R	ManufBlock2	String	20	—	—	—	—
0x6e	R	ManufBlock3	String	20	—	—	—	—
0x6f	R	ManufBlock4	String	20	—	—	—	—
0x70	R/W	ManufacturerInfo	String	31+1	—	—	—	—
0x71	R/W	SenseResistor	Unsigned integer	2	0	65,535	—	$\mu\Omega$
0x72	R	TempRange	Hex	2	—	—	—	—
0x73	R	LifetimeData1	String	32+1	—	—	—	—
0x74	R	LifetimeData2	String	8+1	—	—	—	—
0x77	R/W	DataFlashSubClassID	Hex	2	0x0000	0xffff	—	—
0x78	R/W	DataFlashSubClassPage1	Hex	32	—	—	—	—
0x79	R/W	DataFlashSubClassPage2	Hex	32	—	—	—	—
0x7a	R/W	DataFlashSubClassPage3	Hex	32	—	—	—	—
0x7b	R/W	DataFlashSubClassPage4	Hex	32	—	—	—	—
0x7c	R/W	DataFlashSubClassPage5	Hex	32	—	—	—	—
0x7d	R/W	DataFlashSubClassPage6	Hex	32	—	—	—	—
0x7e	R/W	DataFlashSubClassPage7	Hex	32	—	—	—	—
0x7f	R/W	DataFlashSubClassPage8	Hex	32	—	—	—	—

APPLICATION SCHEMATIC

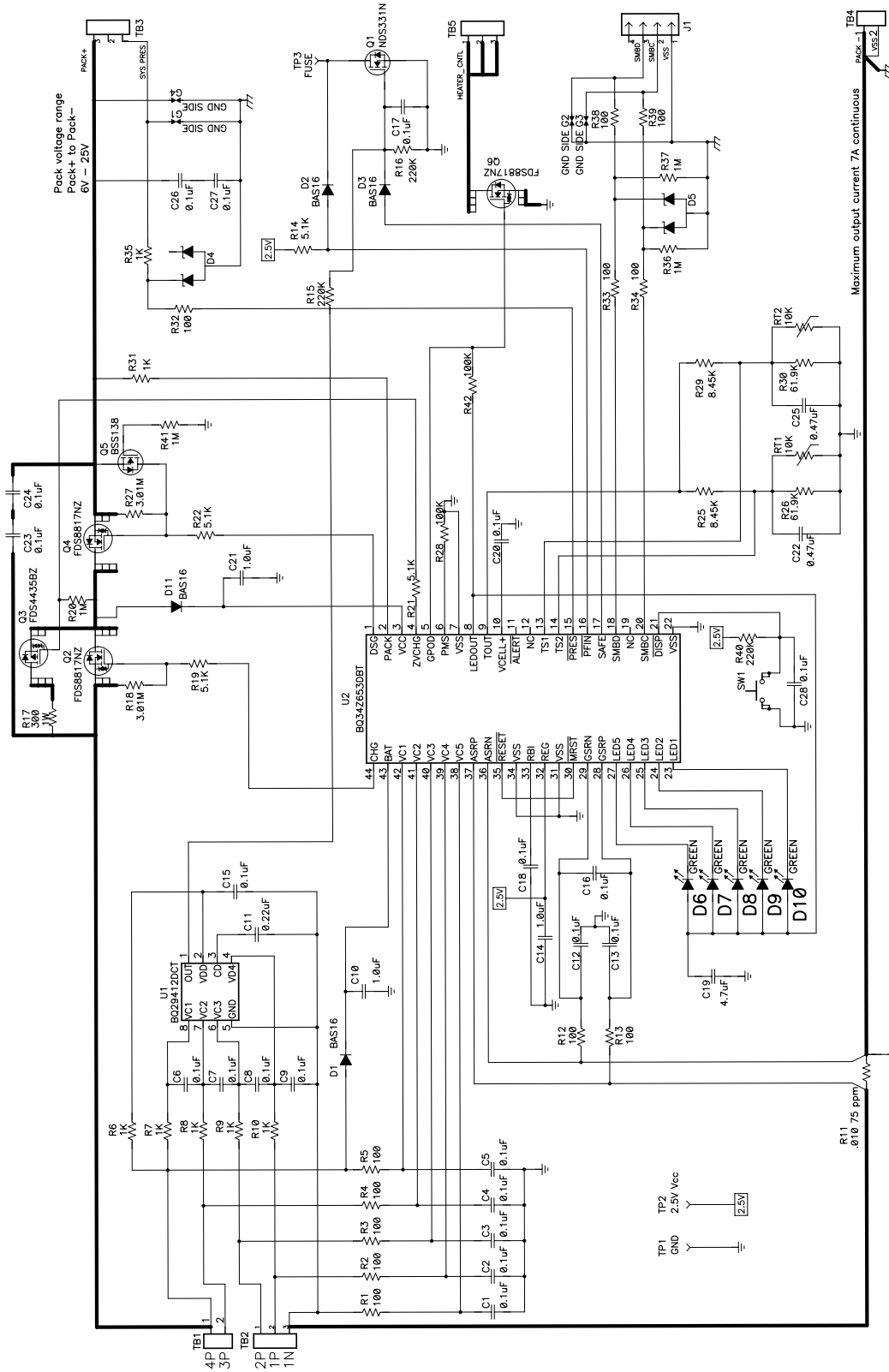

PACKAGING INFORMATION

Orderable Device	Status (1)	Package Type	Package Drawing	Pins	Package Qty	Eco Plan (2)	Lead finish/ Ball material (6)	MSL Peak Temp (3)	Op Temp (°C)	Device Marking (4/5)	Samples
BQ34Z653DBT	ACTIVE	TSSOP	DBT	44	40	RoHS & Green	NIPDAU	Level-2-250C-1 YEAR	-40 to 85	BQ34Z653	Samples
BQ34Z653DBTR	ACTIVE	TSSOP	DBT	44	2000	RoHS & Green	NIPDAU	Level-2-260C-1 YEAR	-40 to 85	BQ34Z653	Samples

(1) The marketing status values are defined as follows:

ACTIVE: Product device recommended for new designs.

LIFEBUY: TI has announced that the device will be discontinued, and a lifetime-buy period is in effect.

NRND: Not recommended for new designs. Device is in production to support existing customers, but TI does not recommend using this part in a new design.

PREVIEW: Device has been announced but is not in production. Samples may or may not be available.

OBSOLETE: TI has discontinued the production of the device.

(2) **RoHS:** TI defines "RoHS" to mean semiconductor products that are compliant with the current EU RoHS requirements for all 10 RoHS substances, including the requirement that RoHS substance do not exceed 0.1% by weight in homogeneous materials. Where designed to be soldered at high temperatures, "RoHS" products are suitable for use in specified lead-free processes. TI may reference these types of products as "Pb-Free".

RoHS Exempt: TI defines "RoHS Exempt" to mean products that contain lead but are compliant with EU RoHS pursuant to a specific EU RoHS exemption.

Green: TI defines "Green" to mean the content of Chlorine (Cl) and Bromine (Br) based flame retardants meet JS709B low halogen requirements of <=1000ppm threshold. Antimony trioxide based flame retardants must also meet the <=1000ppm threshold requirement.

(3) MSL, Peak Temp. - The Moisture Sensitivity Level rating according to the JEDEC industry standard classifications, and peak solder temperature.

(4) There may be additional marking, which relates to the logo, the lot trace code information, or the environmental category on the device.

(5) Multiple Device Markings will be inside parentheses. Only one Device Marking contained in parentheses and separated by a "~" will appear on a device. If a line is indented then it is a continuation of the previous line and the two combined represent the entire Device Marking for that device.

(6) Lead finish/Ball material - Orderable Devices may have multiple material finish options. Finish options are separated by a vertical ruled line. Lead finish/Ball material values may wrap to two lines if the finish value exceeds the maximum column width.

Important Information and Disclaimer:The information provided on this page represents TI's knowledge and belief as of the date that it is provided. TI bases its knowledge and belief on information provided by third parties, and makes no representation or warranty as to the accuracy of such information. Efforts are underway to better integrate information from third parties. TI has taken and continues to take reasonable steps to provide representative and accurate information but may not have conducted destructive testing or chemical analysis on incoming materials and chemicals. TI and TI suppliers consider certain information to be proprietary, and thus CAS numbers and other limited information may not be available for release.

In no event shall TI's liability arising out of such information exceed the total purchase price of the TI part(s) at issue in this document sold by TI to Customer on an annual basis.

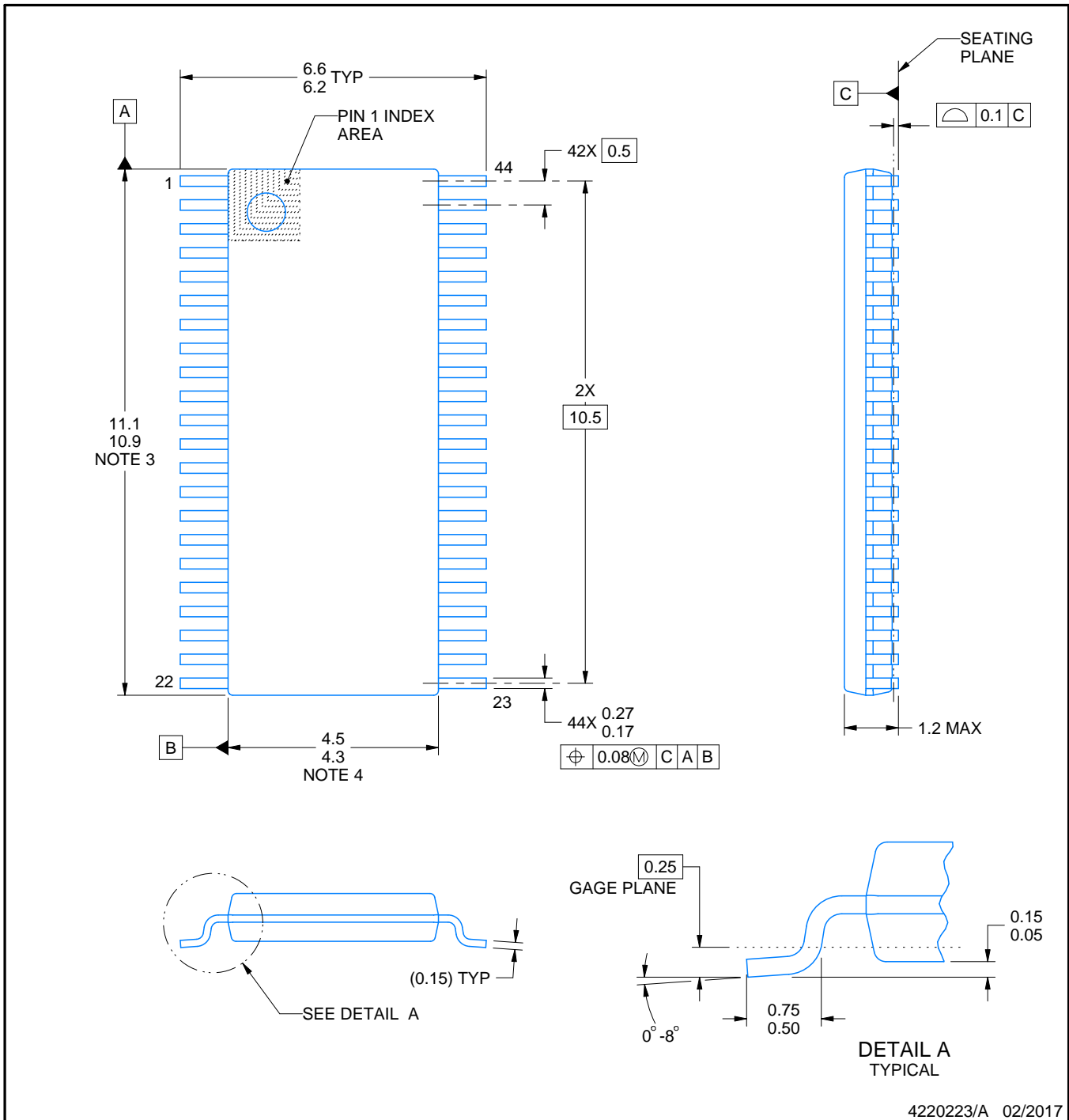
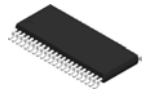

NOTES:

1. All linear dimensions are in millimeters. Any dimensions in parenthesis are for reference only. Dimensioning and tolerancing per ASME Y14.5M.
2. This drawing is subject to change without notice.
3. This dimension does not include mold flash, protrusions, or gate burrs. Mold flash, protrusions, or gate burrs shall not exceed 0.15 mm per side.
4. This dimension does not include interlead flash. Interlead flash shall not exceed 0.25 mm per side.

EXAMPLE BOARD LAYOUT

DBT0044A

TSSOP - 1.2 mm max height

SMALL OUTLINE PACKAGE

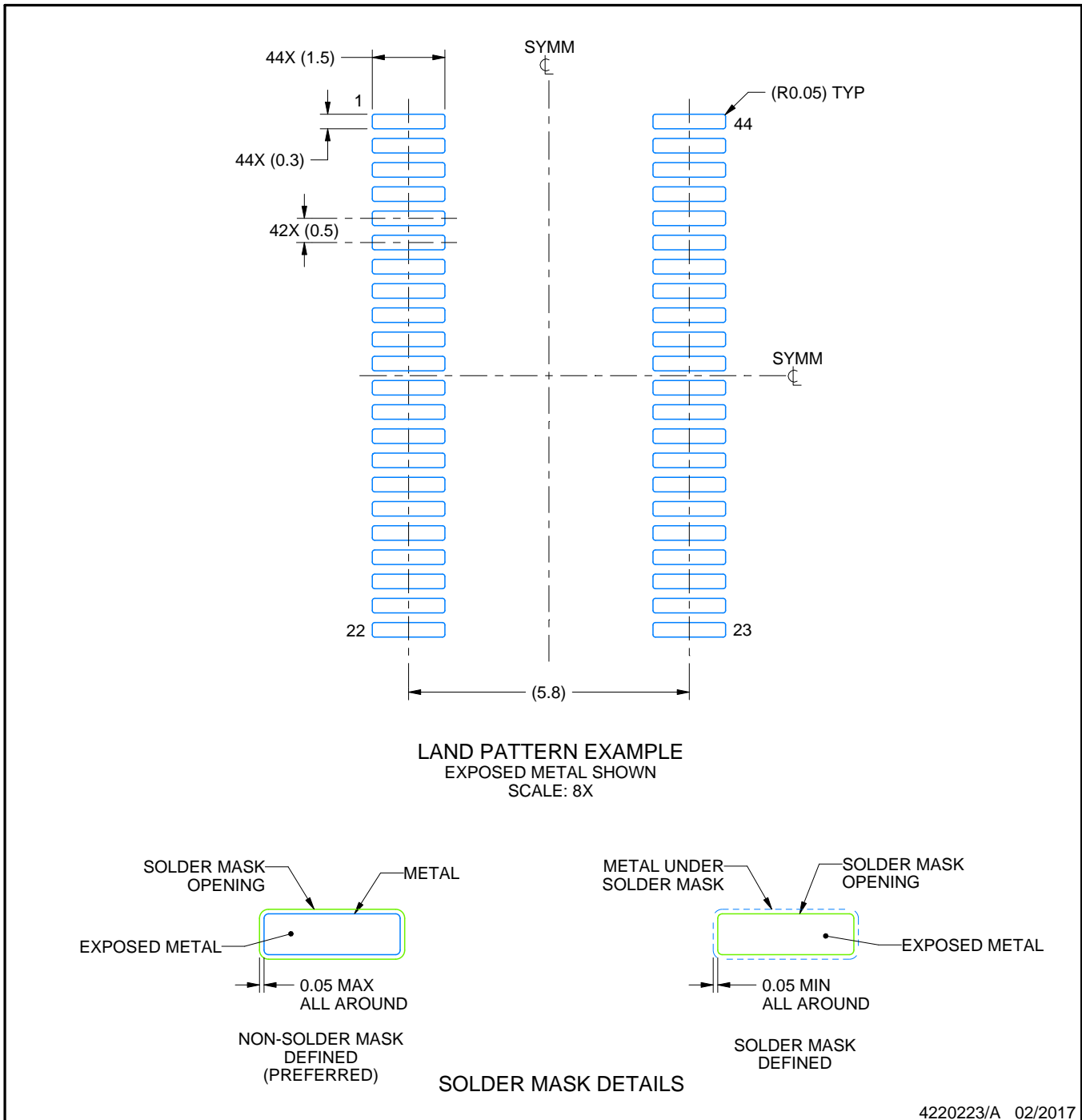

NOTES: (continued)

5. Publication IPC-7351 may have alternate designs.
6. Solder mask tolerances between and around signal pads can vary based on board fabrication site.

EXAMPLE STENCIL DESIGN

DBT0044A

TSSOP - 1.2 mm max height

SMALL OUTLINE PACKAGE

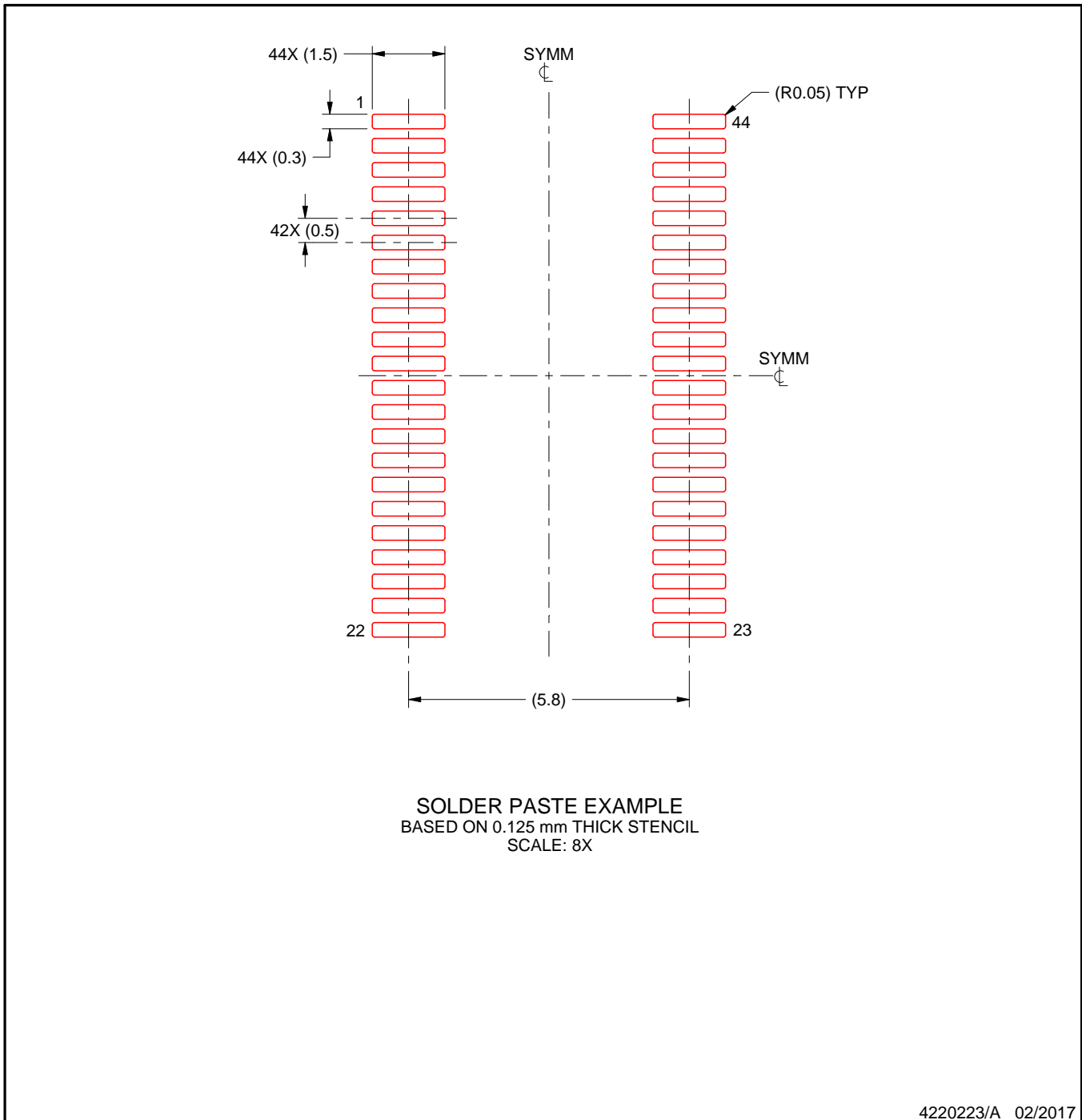

NOTES: (continued)

7. Laser cutting apertures with trapezoidal walls and rounded corners may offer better paste release. IPC-7525 may have alternate design recommendations.
8. Board assembly site may have different recommendations for stencil design.

重要声明和免责声明

TI 均以“原样”提供技术性及其可靠性数据（包括数据表）、设计资源（包括参考设计）、应用或其他设计建议、网络工具、安全信息和其他资源，不保证其中不含任何瑕疵，且不做任何明示或暗示的担保，包括但不限于对适销性、适合某特定用途或不侵犯任何第三方知识产权的暗示担保。

所述资源可供专业开发人员应用TI 产品进行设计使用。您将对以下行为独自承担全部责任：(1) 针对您的应用选择合适的TI 产品；(2) 设计、验证并测试您的应用；(3) 确保您的应用满足相应标准以及任何其他安全、安保或其他要求。所述资源如有变更，恕不另行通知。TI 对您使用所述资源的授权仅限于开发资源所涉及TI 产品的相关应用。除此之外不得复制或展示所述资源，也不提供其它TI 或任何第三方的知识产权授权许可。如因使用所述资源而产生任何索赔、赔偿、成本、损失及债务等，TI 对此概不负责，并且您须赔偿由此对TI 及其代表造成的损害。

TI 所提供产品均受TI 的销售条款 (<http://www.ti.com.cn/zh-cn/legal/termsofsale.html>) 以及ti.com.cn 上或随附TI 产品提供的其他可适用条款的约束。TI 提供所述资源并不扩展或以其他方式更改TI 针对TI 产品所发布的可适用的担保范围或担保免责声明。

邮寄地址：上海市浦东新区世纪大道 1568 号中建大厦 32 楼，邮政编码：200122

Copyright © 2020 德州仪器半导体技术（上海）有限公司