

DAC716

16-Bit DIGITAL-TO-ANALOG CONVERTER with Serial Data Interface

FEATURES:

- SERIAL DIGITAL INTERFACE
- VOLTAGE OUTPUT: 0 to +10V
- ± 2 LSB INTEGRAL LINEARITY
- PRECISION INTERNAL REFERENCE
- LOW NOISE: $120\text{nV}/\sqrt{\text{Hz}}$ Including Reference
- 16-LEAD PLASTIC SKINNY DIP AND PLASTIC SOIC PACKAGES

DESCRIPTION

The DAC716 is a complete monolithic D/A converter including a +10V temperature compensated voltage reference, current-to-voltage amplifier, a high-speed synchronous serial interface, a serial output which allows cascading multiple converters, and an asynchronous clear function which immediately sets the output voltage to zero.

The output voltage range is 0 to +10V while operating from $\pm 12\text{V}$ to $\pm 15\text{V}$ supplies, and the gain and bipolar offset adjustments are designed so that they can be set via external potentiometers or external D/A converters. The output amplifier is protected against short-circuiting to ground.

The 16-pin DAC716 is available in a plastic 0.3" DIP and a wide-body plastic SOIC package. The DAC716P, U, PB, and UB are specified over the -40°C to $+85^\circ\text{C}$ range while the DAC716UK and PK are specified over the 0°C to $+70^\circ\text{C}$ range.

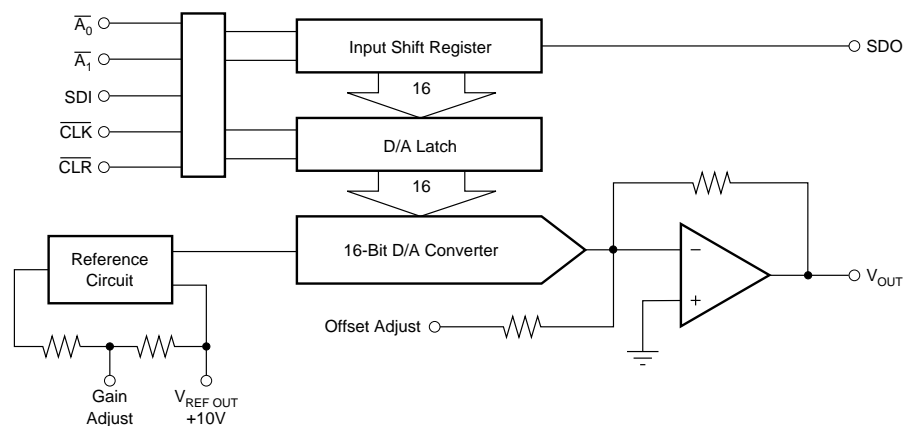

International Airport Industrial Park • Mailing Address: PO Box 11400, Tucson, AZ 85734 • Street Address: 6730 S. Tucson Blvd., Tucson, AZ 85706 • Tel: (520) 746-1111 • Twx: 910-952-1111
Internet: <http://www.burr-brown.com/> • FAXLine: (800) 548-6133 (US/Canada Only) • Cable: BBRCORP • Telex: 066-6491 • FAX: (520) 889-1510 • Immediate Product Info: (800) 548-6132

SPECIFICATIONS

At $T_A = +25^\circ\text{C}$, $+V_{CC} = +15\text{V}$, $-V_{CC} = -15\text{V}$, unless otherwise noted.

PARAMETER	DAC716P, U			DAC716PB, UB			DAC716PK, UK			UNITS
	MIN	TYP	MAX	MIN	TYP	MAX	MIN	TYP	MAX	
TRANSFER CHARACTERISTICS										
ACCURACY										
Linearity Error			± 4			± 2			± 2	LSB
T_{MIN} to T_{MAX}			± 8			± 4			± 2	LSB
Differential Linearity Error			± 4			± 2			± 2	LSB
T_{MIN} to T_{MAX}			± 8			± 4			± 2	LSB
Monotonicity	14			15			15			Bits
Monotonicity Over Spec Temp Range	13			14			15			Bits
Gain Error ⁽³⁾			± 0.1			*			*	%
T_{MIN} to T_{MAX}			± 0.25			*			*	%
Unipolar Zero Error ⁽³⁾			± 0.1			*			*	% of FSR ⁽²⁾
T_{MIN} to T_{MAX}			± 0.2			*			*	% of FSR
Power Supply Sensitivity of Gain			± 0.003			*			*	%FSR/% V_{CC}
			± 30			*			*	ppm FSR/% V_{CC}
DYNAMIC PERFORMANCE										
Settling Time										
(to $\pm 0.003\%$ FSR, $5\text{k}\Omega$ 500pF Load) ⁽⁴⁾										
20V Output Step		6	10		*	*		*	*	μs
1LSB Output Step ⁽⁵⁾		4			*			*		μs
Output Slew Rate		10			*			*		V/ μs
Total Harmonic Distortion										
0dB, 1001Hz, $f_s = 100\text{kHz}$		0.005			*			*		%
-20dB, 1001Hz, $f_s = 100\text{kHz}$		0.03			*			*		%
-60dB, 1001Hz, $f_s = 100\text{kHz}$		3.0			*			*		%
SINAD: 1001Hz, $f_s = 100\text{kHz}$		87			*			*		dB
Digital Feedthrough ⁽⁵⁾		2			*			*		nV-s
Digital-to-Analog Glitch Impulse ⁽⁵⁾		15			*			*		nV-s
Output Noise Voltage (includes reference)		120			*			*		nV/ $\sqrt{\text{Hz}}$
ANALOG OUTPUT										
Output Voltage Range										
$+V_{CC}$, $-V_{CC} = \pm 11.4\text{V}$	+10			*			*			V
Output Current	± 5			*			*			mA
Output Impedance		0.1			*			*		W
Short Circuit to ACOM Duration		Indefinite			*			*		
REFERENCE VOLTAGE										
Voltage	+9.975	+10.000	+10.025	*	*	*	*	*	*	V
T_{MIN} to T_{MAX}	+9.960		+10.040	*	*	*	*	*	*	V
Output Resistance		1			*			*		W
Source Current	2			*			*			mA
Short Circuit to ACOM Duration		Indefinite			*			*		
INTERFACE										
RESOLUTION										
DIGITAL INPUTS		16			*			*		Bits
Serial Data Input Code										
Logic Levels ⁽¹⁾				Straight Binary						
V_{IH}	+2.0		($V_{CC} - 1.4$)	*		*	*	*	*	V
V_{IL}	0		+0.8	*		*	*	*	*	V
I_{IH} ($V_I = +2.7\text{V}$)			± 10			*		*	*	μA
I_{IL} ($V_I = +0.4\text{V}$)			± 10			*		*	*	μA
DIGITAL OUTPUT										
Serial Data										
V_{OL} ($I_{\text{SINK}} = 1.6\text{mA}$)	0		+0.4	*		*	*	*	*	V
V_{OH} ($I_{\text{SOURCE}} = 500\mu\text{A}$), T_{MIN} to T_{MAX}	+2.4		+5	*		*	*	*	*	V
POWER SUPPLY REQUIREMENTS										
Voltage										
$+V_{CC}$	+11.4	+15	+16.5	*	*	*	*	*	*	V
$-V_{CC}$	-11.4	-15	-16.5	*	*	*	*	*	*	V
Current (No Load, $\pm 15\text{V}$ Supplies) ⁽⁶⁾										
$+V_{CC}$		13	16		*	*		*	*	mA
$-V_{CC}$		22	26		*	*		*	*	mA
Power Dissipation ⁽⁷⁾			625			*			*	mW
TEMPERATURE RANGES										
Specification										
All Grades	-40		+85	*		*	0		+70	$^\circ\text{C}$
Storage	-60		+150	*		*	*		*	$^\circ\text{C}$
Thermal Coefficient, θ_{JA}		75			*			*		$^\circ\text{C/W}$

* Specifications are the same as the grade to the left.

NOTES: (1) Digital inputs are TTL and +5V CMOS compatible over the specification temperature range. (2) FSR means Full Scale Range. For example, for 0 to +10V output, FSR = 10V. (3) Errors externally adjustable to zero. (4) Maximum represents the 3σ limit. Not 100% tested for this parameter. (5) For the worst-case Straight Binary code changes: 7FFF to 8000 and 8000 to 7FFF. (6) During power supply turn on, the transient supply current may approach 3x the maximum quiescent specification. (7) Typical (i.e. rated) supply voltages times maximum currents.



DAC716

PIN CONFIGURATION

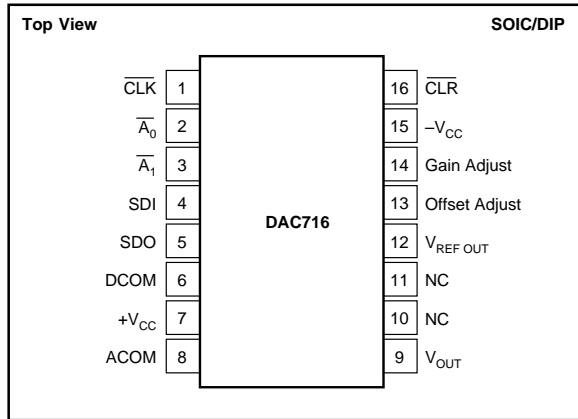

PIN DESCRIPTIONS

PIN	LABEL	DESCRIPTION
1	CLK	Serial Data Clock
2	A ₀	Enable for Input Register (Active Low)
3	A ₁	Enable for D/A Latch (Active Low)
4	SDI	Serial Data Input
5	SDO	Serial Data Output
6	DCOM	Digital Supply Ground
7	+V _{CC}	Positive Power Supply
8	ACOM	Analog Supply Ground
9	V _{OUT}	D/A Output
10	NC	No Connection
11	NC	No Connection
12	V _{REF OUT}	Voltage Reference Output
13	Offset Adjust	Offset Adjust
14	Gain Adjust	Gain Adjust
15	-V _{CC}	Negative Power Supply
16	CLR	Clear



ELECTROSTATIC DISCHARGE SENSITIVITY

Electrostatic discharge can cause damage ranging from performance degradation to complete device failure. Burr-Brown Corporation recommends that all integrated circuits be handled and stored using appropriate ESD protection methods.

ESD damage can range from subtle performance degradation to complete device failure. Precision integrated circuits may be more susceptible to damage because very small parametric changes could cause the device not to meet published specifications.

ABSOLUTE MAXIMUM RATINGS⁽¹⁾

+V _{CC} to Common	0V to +17V
-V _{CC} to Common	0V to -17V
+V _{CC} to -V _{CC}	34V
ACOM to DCOM	±0.5V
Digital Inputs to Common	-1V to (V _{CC} -0.7V)
External Voltage Applied to BPO and Range Resistors	±V _{CC}
V _{REF OUT}	Indefinite Short to Common
V _{OUT}	Indefinite Short to Common
SDO	Indefinite Short to Common
Power Dissipation	750mW
Storage Temperature	-60°C to +150°C
Lead Temperature (soldering, 10s)	+300°C

NOTE: (1) Stresses above those listed under "Absolute Maximum Ratings" may cause permanent damage to the device. Exposure to absolute maximum conditions for extended periods may affect device reliability.

ORDERING INFORMATION

PRODUCT	PACKAGE	DIFFERENTIAL LINEARITY ERROR T _{MIN} to T _{MAX}	TEMPERATURE RANGE
DAC716P	Plastic DIP	±8 LSB	-40°C to +85°C
DAC716U	Plastic SOIC	±8 LSB	-40°C to +85°C
DAC716PB	Plastic DIP	±4 LSB	-40°C to +85°C
DAC716UB	Plastic SOIC	±4 LSB	-40°C to +85°C
DAC716PK	Plastic DIP	±2 LSB	0°C to +70°C
DAC716UK	Plastic SOIC	±2 LSB	0°C to +70°C

PACKAGE INFORMATION

PRODUCT	PACKAGE	PACKAGE DRAWING NUMBER ⁽¹⁾
DAC716P	Plastic DIP	180
DAC716U	Plastic SOIC	211

NOTE: (1) For detailed drawing and dimension table, please see end of data sheet, or Appendix C of Burr-Brown IC Data Book.

The information provided herein is believed to be reliable; however, BURR-BROWN assumes no responsibility for inaccuracies or omissions. BURR-BROWN assumes no responsibility for the use of this information, and all use of such information shall be entirely at the user's own risk. Prices and specifications are subject to change without notice. No patent rights or licenses to any of the circuits described herein are implied or granted to any third party. BURR-BROWN does not authorize or warrant any BURR-BROWN product for use in life support devices and/or systems.

TIMING SPECIFICATIONS

$T_A = -40^\circ\text{C}$ to $+85^\circ\text{C}$, $+V_{CC} = +15\text{V}$, $-V_{CC} = -15\text{V}$.

SYMBOL	PARAMETER	MIN	MAX	UNITS
t_{CLK}	Data Clock Period	100		ns
t_{CL}	Clock LOW	50		ns
t_{CH}	Clock HIGH	50		ns
t_{A0S}	Setup Time for $\overline{A_0}$	50		ns
t_{A1S}	Setup Time for $\overline{A_1}$	50		ns
t_{A0H}	Hold Time for $\overline{A_0}$	10		ns
t_{A1H}	Hold Time for $\overline{A_1}$	10		ns
t_{DS}	Setup Time for DATA	50		ns
t_{DH}	Hold Time for DATA	10		ns
t_{DSOP}	Output Propagation Delay	140		ns
t_{CP}	Clear Pulsewidth	200		ns

TRUTH TABLE

$\overline{A_0}$	$\overline{A_1}$	CLK	CLR	DESCRIPTION
0	1	1 → 0 → 1	1	Shift Serial Data into SDI
1	0	1 → 0 → 1	1	Load D/A Latch
1	1	1 → 0 → 1	1	No Change
0	0	1 → 0 → 1	1	Two Wire Operation ⁽¹⁾
X	X	1	1	No Change
X	X	X	0	Reset D/A Latch

NOTES: X = Don't Care. (1) All digital input changes will appear at the D/A output.

TIMING DIAGRAMS

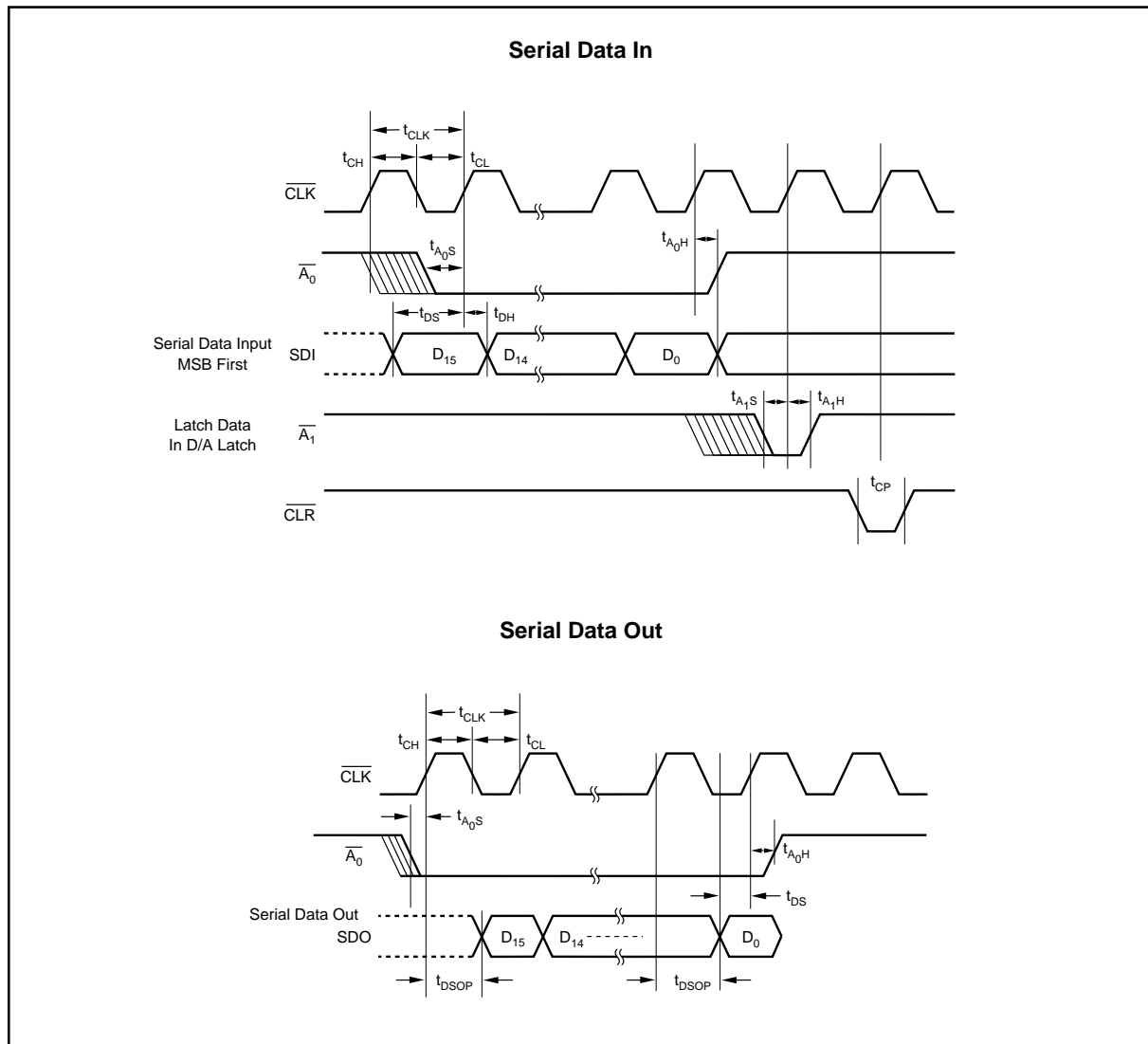

TYPICAL PERFORMANCE CURVES

At $T_A = +25^\circ\text{C}$, $V_{CC} = \pm 15\text{V}$, unless otherwise noted.

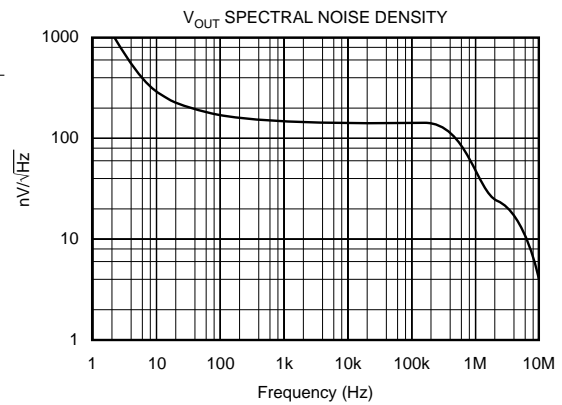
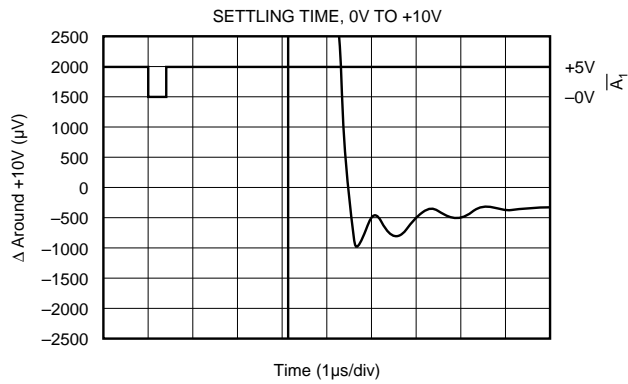
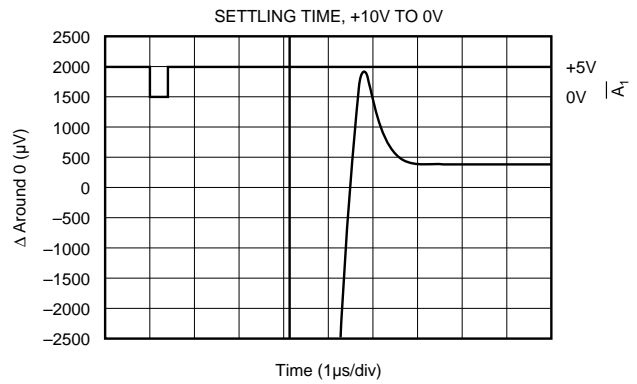
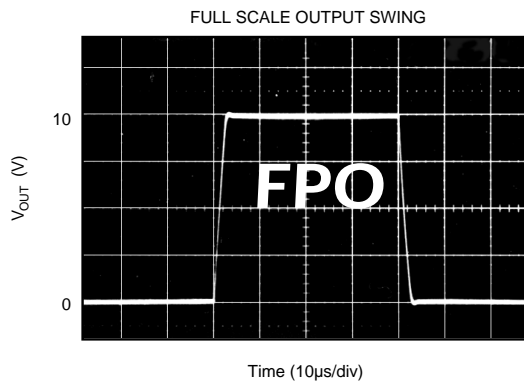
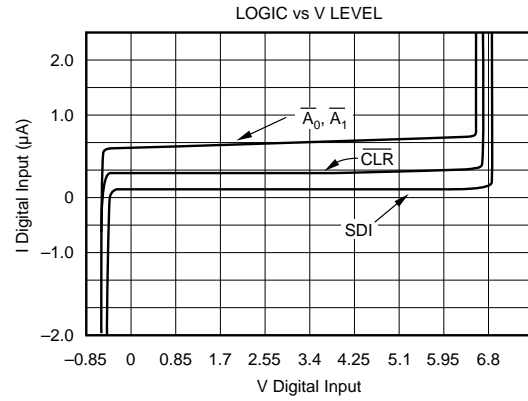
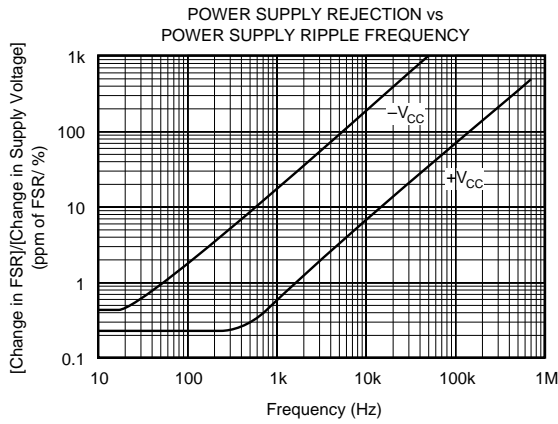

DISCUSSION OF SPECIFICATIONS

LINEARITY ERROR

Linearity error is defined as the deviation of the analog output from a straight line drawn between the end points of the transfer characteristic.

DIFFERENTIAL LINEARITY ERROR

Differential linearity error (DLE) is the deviation from 1LSB of an output change from one adjacent state to the next. A DLE specification of $\pm 1/2$ LSB means that the output step size can range from $1/2$ LSB to $3/2$ LSB when the digital input code changes from one code word to the adjacent code word. If the DLE is more positive than -1 LSB, the D/A is said to be monotonic.

MONOTONICITY

A D/A converter is monotonic if the output either increases or remains the same for increasing digital input values. Monotonicity of the K grade is guaranteed over the specification temperature range to 15 bits.

SETTLING TIME

Settling time is the total time (including slew time) for the D/A output to settle to within an error band around its final value after a change in input. Settling times are specified to within $\pm 0.003\%$ of Full Scale Range (FSR) for an output step change of 10V and 1LSB. The 1LSB change is measured at the Major Carry (7FFF to 8000, and 8000 to 7FFF: Straight Binary codes), the input transition at which worst-case settling time occurs.

TOTAL HARMONIC DISTORTION + NOISE

Total harmonic distortion + noise is defined as the ratio of the square root of the sum of the squares of the values of the harmonics and noise to the value of the fundamental frequency. It is expressed in % of the fundamental frequency amplitude at sampling rate f_s .

SIGNAL-TO-NOISE AND DISTORTION RATIO (SINAD)

SINAD includes all the harmonic and outstanding spurious components in the definition of output noise power in addition to quantizing and internal random noise power. SINAD is expressed in dB at a specified input frequency and sampling rate, f_s .

DIGITAL-TO-ANALOG GLITCH IMPULSE

The amount of charge injected into the analog output from the digital inputs when the inputs change state. It is measured at half scale at the input codes where as many as possible switches change state—from 8000 to 7FFF.

DIGITAL FEEDTHROUGH

When the A/D is not selected, high frequency logic activity on the digital inputs is coupled through the device and shows up as output noise. This noise is digital feedthrough.

OPERATION

The DAC716 is a monolithic integrated-circuit 16-bit D/A converter complete with 16-bit D/A switches and ladder network, voltage reference, output amplifier and a serial interface.

INTERFACE LOGIC

The DAC716 has double-buffered data latches. The input data latch holds a 16-bit data word before loading it into the second latch, the D/A latch. This double-buffered organization permits simultaneous update of several D/A converters. All digital control inputs are active low. Refer to block diagram of Figure 1.

All latches are level-triggered. Data present when the enable inputs are logic "0" will enter the latch. When the enable inputs return to logic "1", the data is latched.

The $\overline{\text{CLR}}$ input resets both the input latch and the D/A latch to give an output voltage of 0V (code 0000).

LOGIC INPUT COMPATIBILITY

DAC716 digital inputs are TTL compatible (1.4V switching level) with low leakage, high impedance inputs. Thus the inputs are suitable for being driven by any type of 5V logic such as 5V CMOS logic. An equivalent circuit of a digital input is shown in Figure 2.

Data inputs will float to logic "0" and control inputs will float to logic "0" if left unconnected. It is recommended that any unused inputs be connected to DCOM to improve noise immunity.

Digital inputs remain high impedance when power is off.

INPUT CODING

The DAC716 is designed to accept Straight Binary (SB) input codes. The serial input format is MSB first.

INTERNAL REFERENCE

DAC716 contains a +10V reference.

The reference output may be used to drive external loads, sourcing up to 2mA. The load current should be constant, otherwise the gain and unipolar offset of the converter will vary.

OUTPUT VOLTAGE SWING

The output amplifier of DAC716 is designed to achieve a +10V output range. DAC716 will provide a +10V output swing while operating on ± 11.4 V or higher voltage supplies.

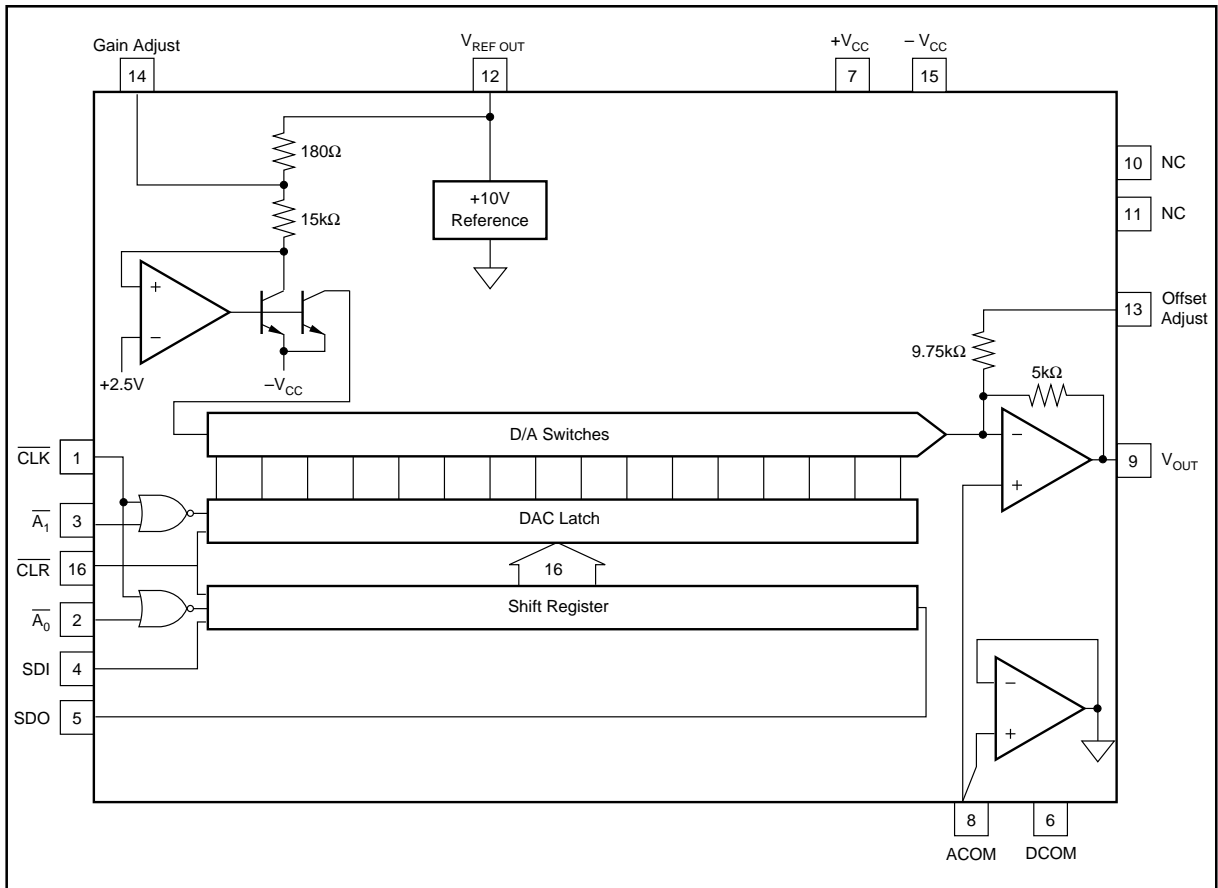

FIGURE 1. DAC716 Block Diagram.

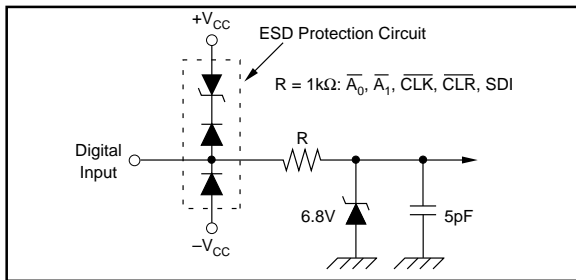

FIGURE 2. Equivalent Circuit of Digital Inputs.

GAIN AND OFFSET ADJUSTMENTS

Figure 3 illustrates the relationship of offset and gain adjustments for a unipolar connected D/A converter. Offset should be adjusted first to avoid interaction of adjustments. See Table I for calibration values and codes. These adjustments have a minimum range of $\pm 0.3\%$.

Offset Adjustment

Apply the digital input code, 0000, that produces 0V and adjust the offset potentiometer or the offset adjust D/A converter for 0V.

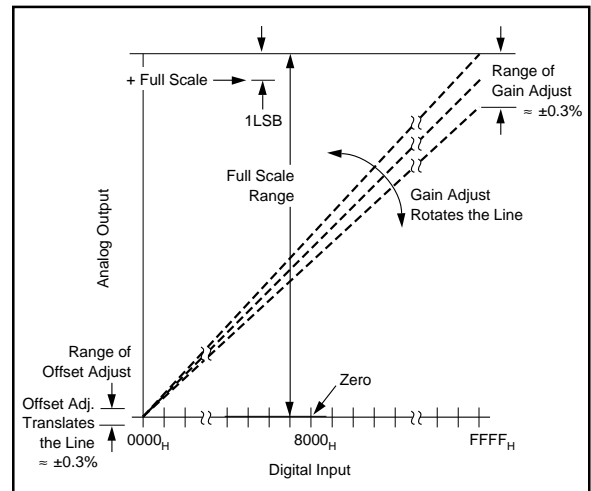

FIGURE 3. Relationship of Offset and Gain Adjustments.

Gain Adjustment

Apply the digital input that gives the maximum positive voltage output. Adjust the gain potentiometer or the gain adjust D/A converter for this positive full scale voltage.

DAC716 CALIBRATION VALUES 1 LEAST SIGNIFICANT BIT = 152 μ V		
DIGITAL INPUT CODE	ANALOG OUTPUT (V)	
STRAIGHT BINARY	UNIPOLAR 10V RANGE	DESCRIPTION
FFFF _H	+9.999695	+ Full Scale -1LSB
8000 _H	+5.000000	Half Scale
0000 _H	0.000000	Unipolar Zero

TABLE I. Digital Input and Analog Output Voltage Calibration Values.

INSTALLATION

GENERAL CONSIDERATIONS

Due to the high precision of these D/A converters, system design problems such as grounding and contact resistance become very important. A 16-bit converter with a 10V full-scale range has a 1LSB value of 152 μ V. With a load current of 5mA, series wiring and connector resistance of only 60m Ω will cause a voltage drop of 300 μ V. To understand what this means in terms of a system layout, the resistivity of a typical 1 ounce copper-clad printed circuit board is 1/2 m Ω per square. For a 5mA load, a 0.1 inch wide printed circuit conductor 0.6 inches long will result in a voltage drop of 150 μ V.

The analog output of DAC716 has an LSB size of 152 μ V (-96dB). The rms noise floor of the D/A should remain below this level in the frequency range of interest. The DAC716's output noise spectral density (which includes the noise contributed by the internal reference) is shown in the Typical Performance Curves section.

Wiring to high-resolution D/A converters should be routed to provide optimum isolation from sources of RFI and EMI. The key to elimination of RF radiation or pickup is small loop area. Signal leads and their return conductors should be kept close together such that they present a small capture cross-section for any external field. Wire-wrap construction is not recommended.

POWER SUPPLY AND REFERENCE CONNECTIONS

Power supply decoupling capacitors should be added as shown in Figure 4. Best performance occurs using a 1 to 10 μ F tantalum capacitor at $-V_{CC}$. Applications with less critical settling time may be able to use 0.01 μ F at $-V_{CC}$ as well as at $+V_{CC}$. The capacitors should be located close to the package.

The DAC716 has separate ANALOG COMMON and DIGITAL COMMON pins. The current through DCOM is mostly switching transients and are up to 1mA peak in amplitude. The current through ACOM is typically 5 μ A for all codes.

Use separate analog and digital ground planes with a single interconnection point to minimize ground loops. The analog

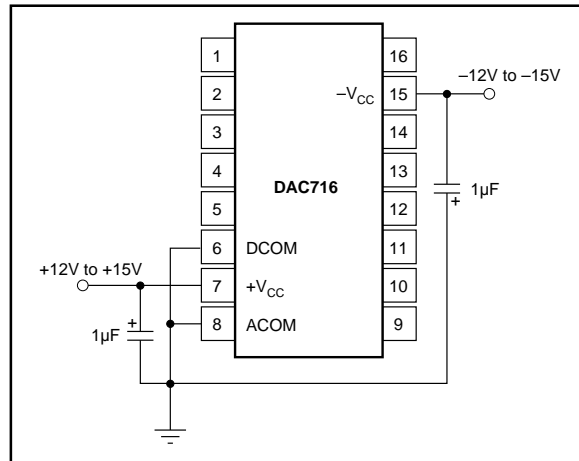

FIGURE 4. Power Supply Connections.

pins are located adjacent to each other to help isolate analog from digital signals. Analog signals should be routed as far as possible from digital signals and should cross them at right angles. A solid analog ground plane around the D/A package, as well as under it in the vicinity of the analog and power supply pins, will isolate the D/A from switching currents. It is recommended that DCOM and ACOM be connected directly to the ground planes under the package.

If several DAC716s are used or if the DAC716 shares supplies with other components, connecting the ACOM and DCOM lines together at the power supplies only rather than at each chip, may give better results.

LOAD CONNECTIONS

Since the reference point for V_{OUT} and $V_{REF OUT}$ is the ACOM pin, it is important to connect the D/A converter load directly to the ACOM pin. Refer to Figure 5.

Lead and contact resistances are represented by R_1 through R_3 . As long as the load resistance R_L is constant, R_1 simply introduces a gain error and can be removed by gain adjustment of the D/A or system-wide gain calibration. R_2 is part of R_L if the output voltage is sensed at ACOM.

In some applications it is impractical to return the load to the ACOM pin of the D/A converter. Sensing the output voltage at the SYSTEM GROUND point is reasonable, because there is no change in DAC716 ACOM current, provided that R_3 is a low-resistance ground plane or conductor. In this case you may wish to connect DCOM to SYSTEM GROUND as well.

GAIN AND OFFSET ADJUST

Connections Using Potentiometers

GAIN and OFFSET adjust pins provide for trim using external potentiometers. 15-turn potentiometers provide sufficient resolution. Range of adjustment of these trims is at least $\pm 0.3\%$ of Full Scale Range. Refer to Figure 6.

Using D/A Converters

The GAIN ADJUST and OFFSET ADJUST circuits of DAC716 have been arranged so that these points may be easily driven by external D/A converters. Refer to Figure 7. 12-bit D/A converters provide a nominal OFFSET adjust and GAIN adjust resolution of $25\mu\text{V}$ and $15\mu\text{V}$ per LSB step, respectively.

Nominal values of GAIN and OFFSET occur when the D/A converters outputs are at approximately half scale, 0V.

OUTPUT VOLTAGE RANGE CONNECTIONS

The DAC716 output amplifier is connected internally for 10V output range.

DIGITAL INTERFACE

SERIAL INTERFACE

The DAC716 has a serial interface with two data buffers which can be used for either synchronous or asynchronous updating of multiple D/A converters. $\overline{A0}$ is the enable control for the Data Input Latch. $\overline{A1}$ is the enable for the D/A Latch. \overline{CLK} is used to strobe data into the latches enabled by $\overline{A0}$ and $\overline{A1}$. A \overline{CLR} function is also provided and when enabled it sets both the Data Latch and the D/A Latch to all zeros.

Multiple DAC716s can be connected to the same \overline{CLK} and data lines in two ways. The output of the serial loaded data latch is available as SDO so that any number of DAC716s can be cascaded on the same input bit stream as shown in Figure 8 and 9. This configuration allows all D/A converters to be updated simultaneously and requires a minimum number of control signal inputs. These configurations do require $16N$ \overline{CLK} cycles to load any given D/A converter, where N is the number of D/A converters.

The DAC716 can also be connected in parallel as shown in Figure 10. This configuration allows any D/A converter in the system to be updated in a maximum of 16 \overline{CLK} cycles.

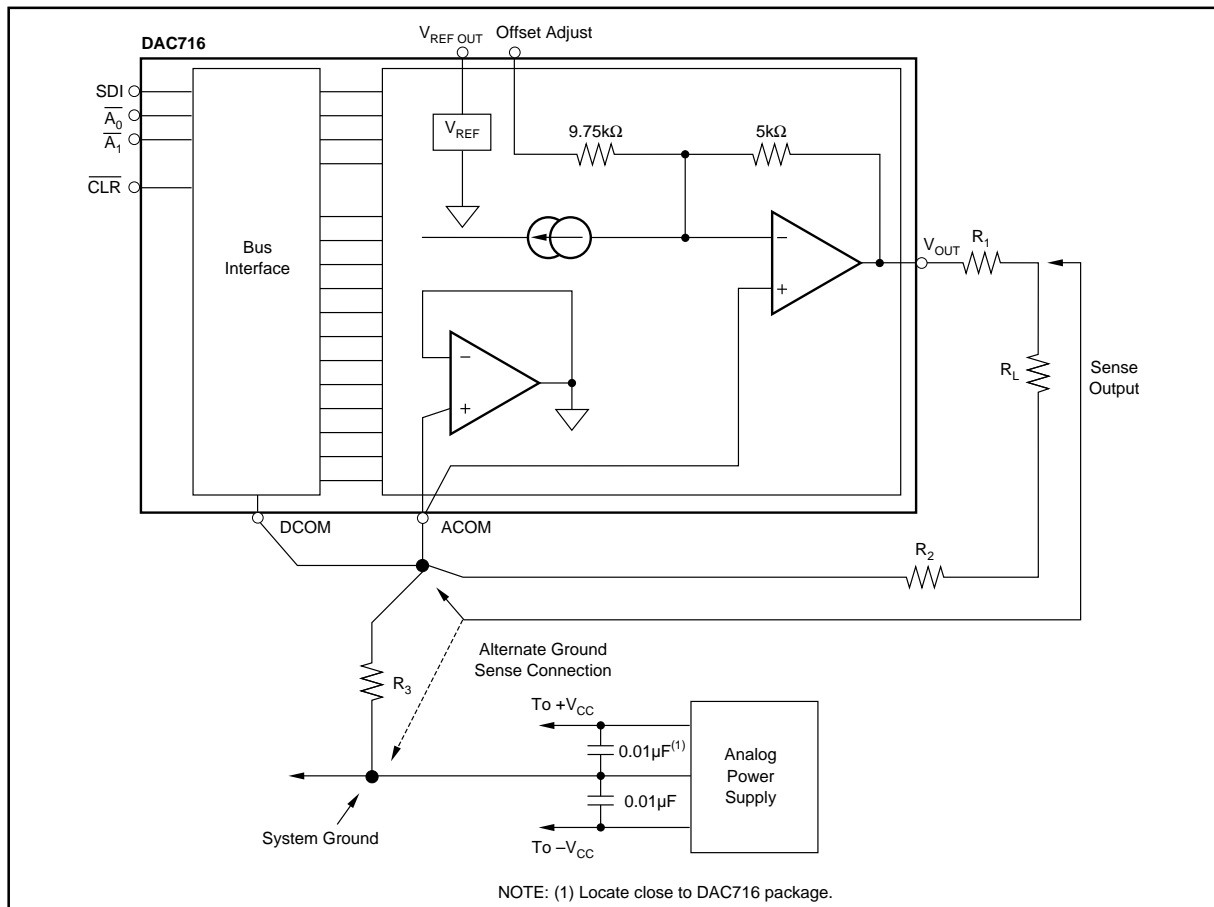

FIGURE 5. System Ground Considerations for High-Resolution D/A Converters.

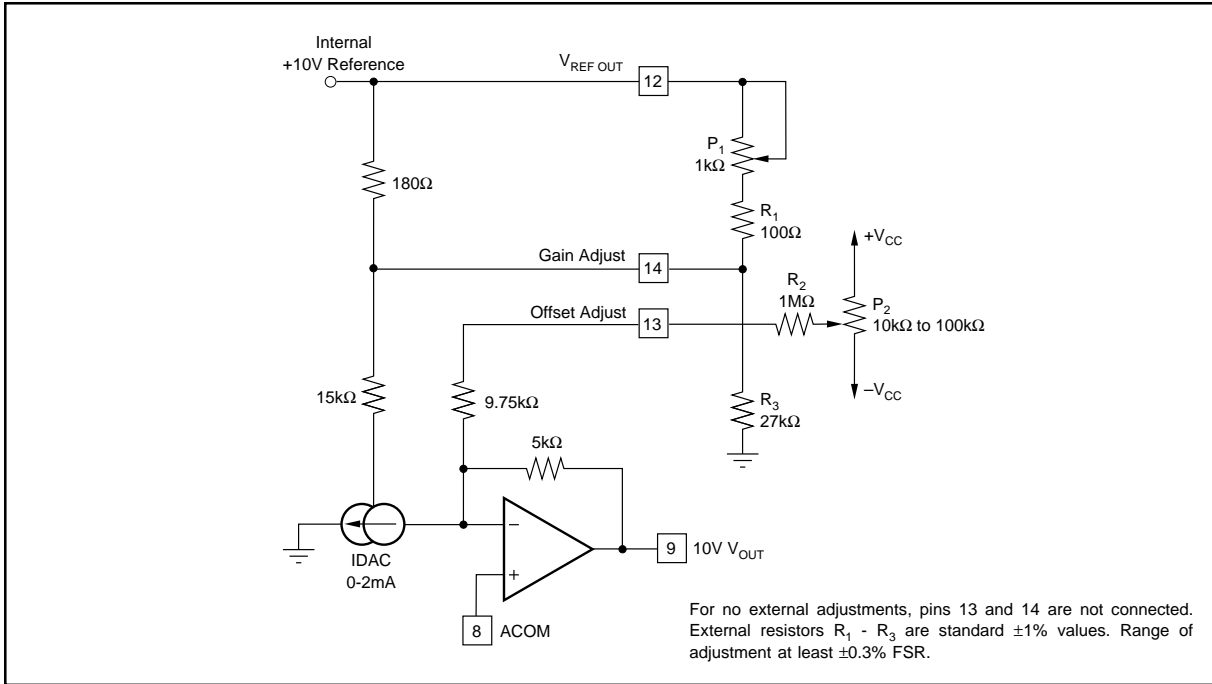

FIGURE 6. Manual Offset and Gain Adjust Circuits.

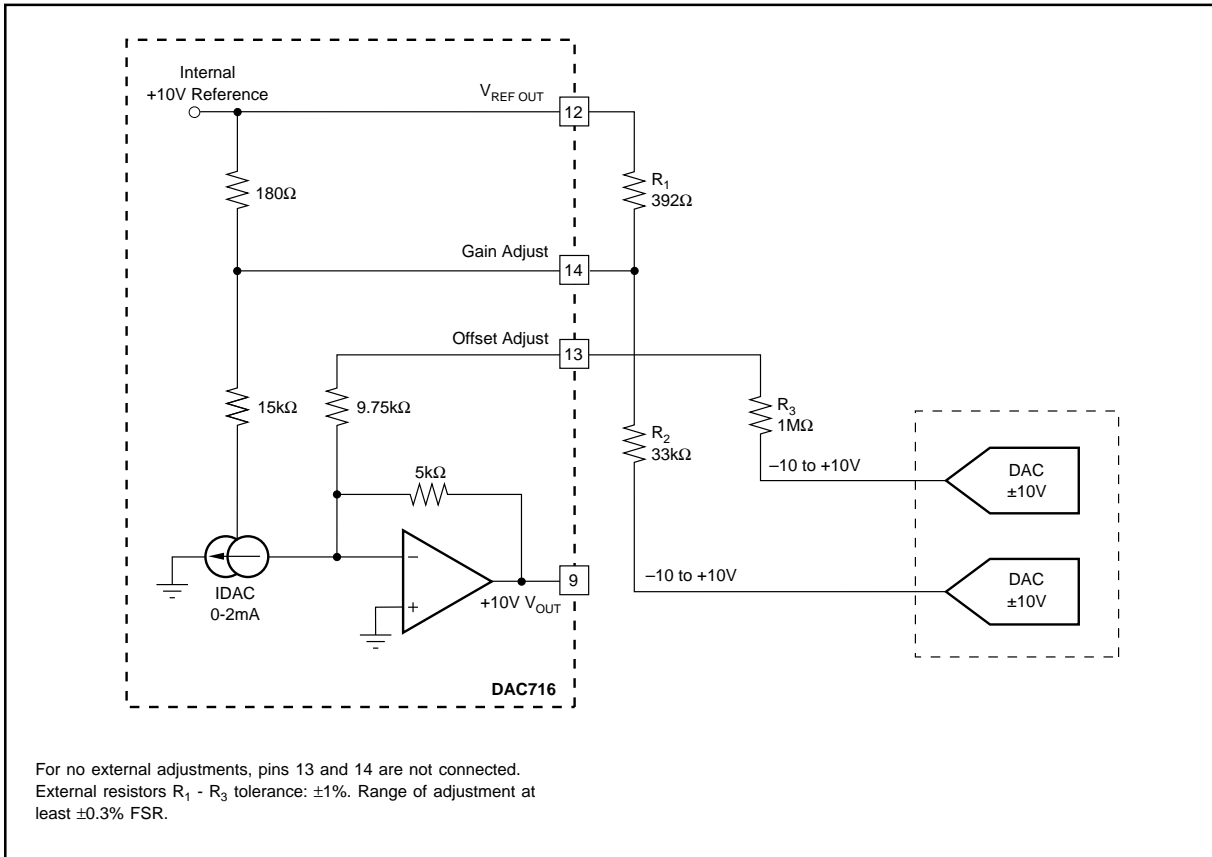

FIGURE 7. Gain and Offset Adjustment Using D/A Converters.

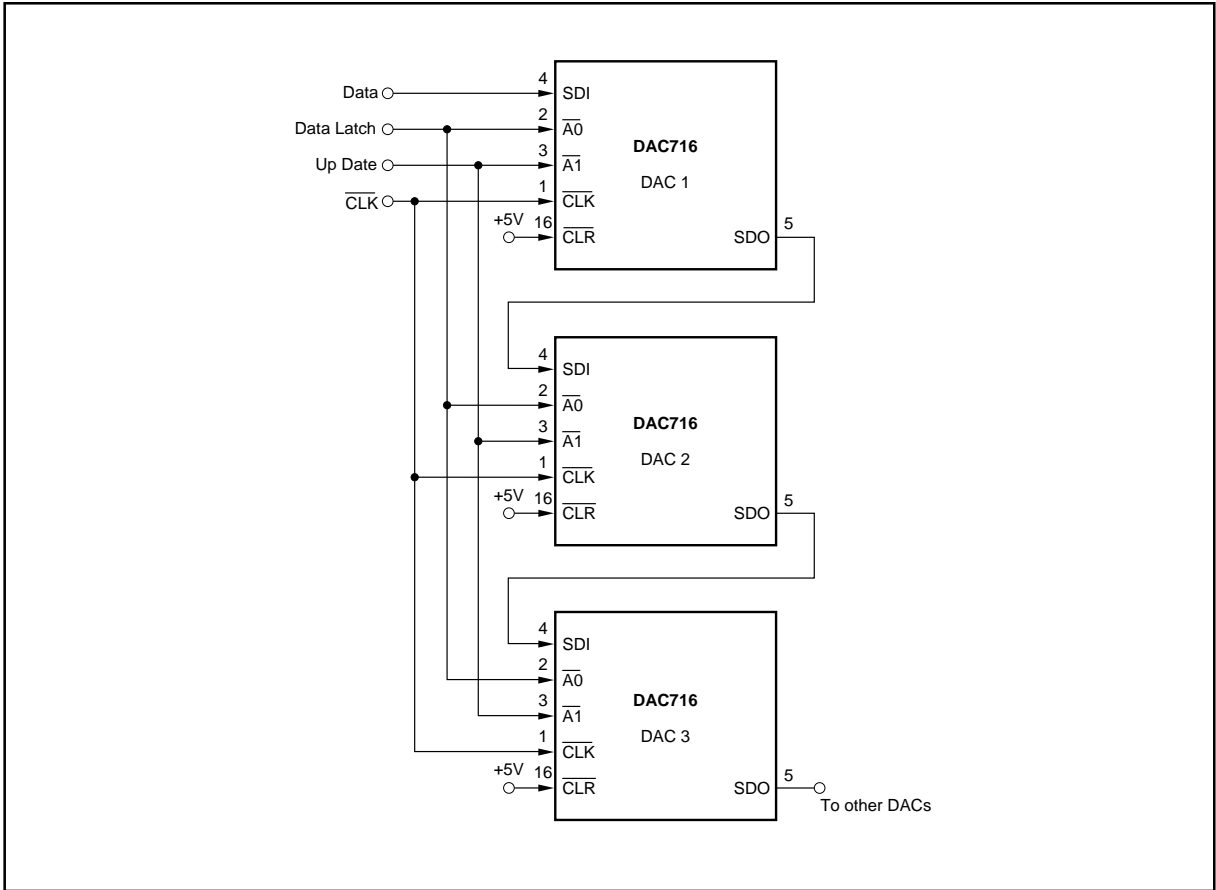

FIGURE 8a. Cascaded Serial Bus Connection with Synchronous Update.

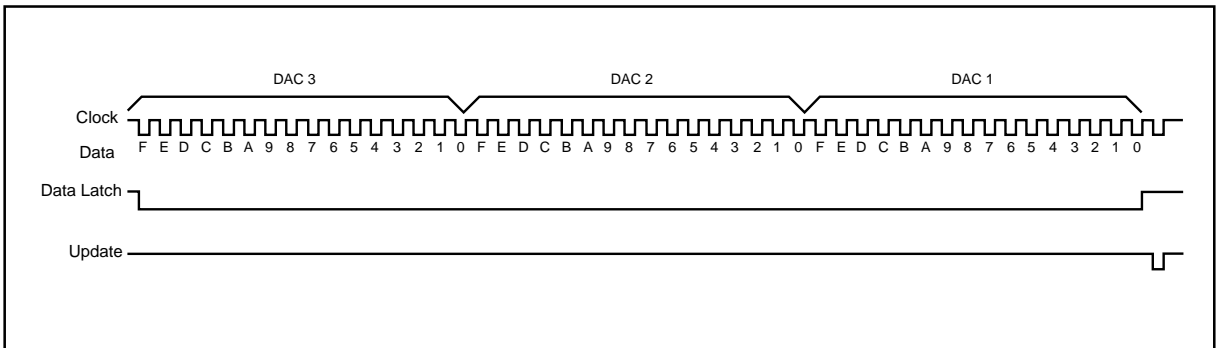

FIGURE 8b. Timing Diagram For Figure 8a.

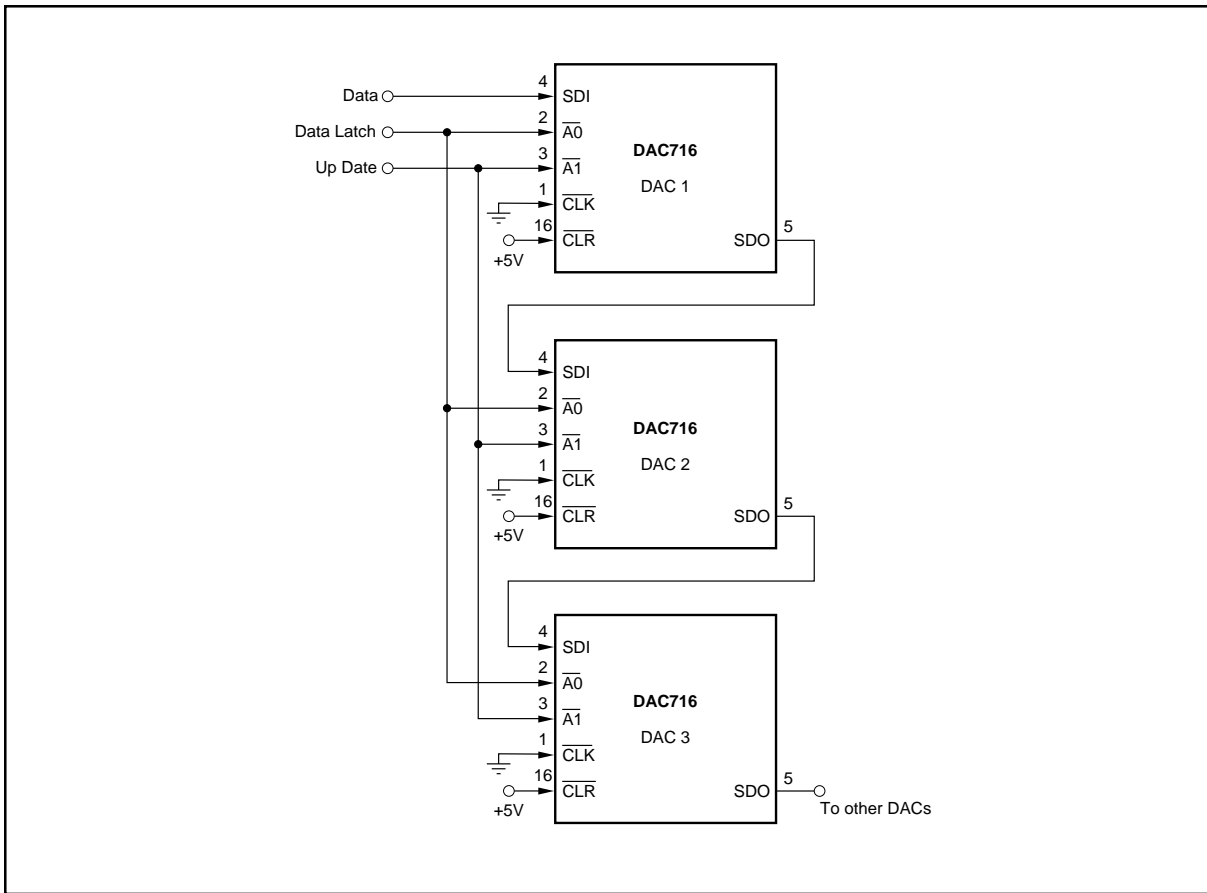

FIGURE 9a. Cascaded Serial Bus Connection with Asynchronous Update.

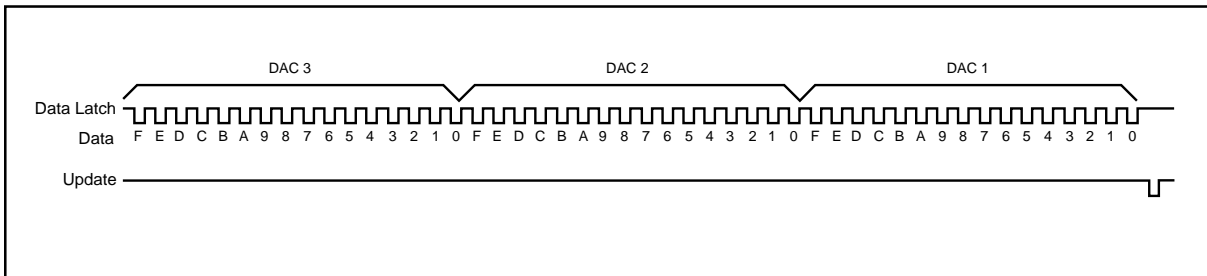

FIGURE 9b. Timing Diagram For Figure 9a.

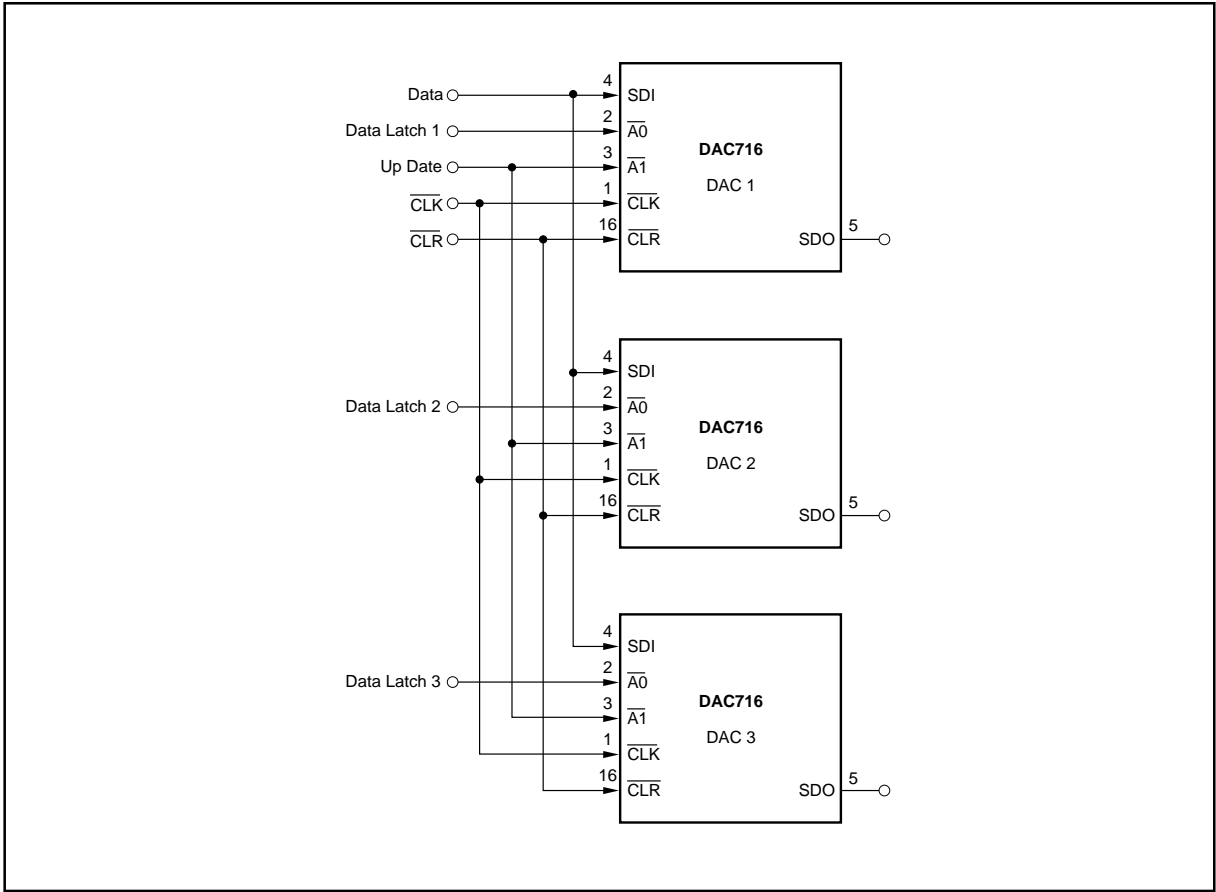

FIGURE 10a. Parallel Bus Connection.

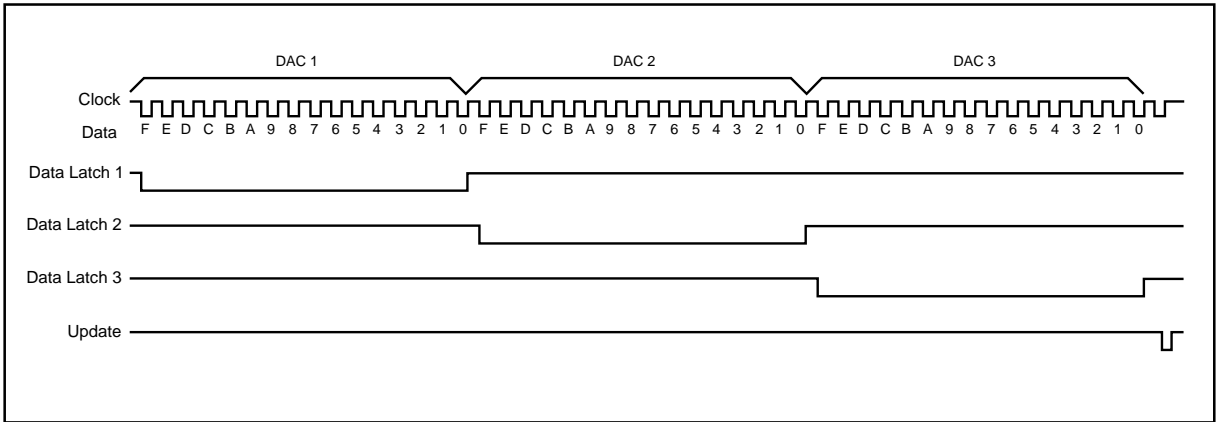

FIGURE 10b. Timing Diagram For Figure 10a.

PACKAGING INFORMATION

Orderable Device	Status (1)	Package Type	Package Drawing	Pins	Package Qty	Eco Plan (2)	Lead finish/ Ball material (6)	MSL Peak Temp (3)	Op Temp (°C)	Device Marking (4/5)	Samples
DAC716PB	ACTIVE	PDIP	N	16	25	RoHS & Green	Call TI	N / A for Pkg Type	-40 to 85	DAC716P B	Samples
DAC716PK	ACTIVE	PDIP	N	16	25	RoHS & Green	NIPDAU	N / A for Pkg Type	0 to 70	DAC716PK	Samples
DAC716UB	ACTIVE	SOIC	DW	16	40	RoHS & Green	NIPDAU	Level-3-260C-168 HR	-40 to 85	DAC716U B	Samples
DAC716UK	ACTIVE	SOIC	DW	16	40	RoHS & Green	NIPDAU	Level-3-260C-168 HR	0 to 70	DAC716UK	Samples

(1) The marketing status values are defined as follows:

ACTIVE: Product device recommended for new designs.

LIFEBUY: TI has announced that the device will be discontinued, and a lifetime-buy period is in effect.

NRND: Not recommended for new designs. Device is in production to support existing customers, but TI does not recommend using this part in a new design.

PREVIEW: Device has been announced but is not in production. Samples may or may not be available.

OBSOLETE: TI has discontinued the production of the device.

(2) **RoHS:** TI defines "RoHS" to mean semiconductor products that are compliant with the current EU RoHS requirements for all 10 RoHS substances, including the requirement that RoHS substance do not exceed 0.1% by weight in homogeneous materials. Where designed to be soldered at high temperatures, "RoHS" products are suitable for use in specified lead-free processes. TI may reference these types of products as "Pb-Free".

RoHS Exempt: TI defines "RoHS Exempt" to mean products that contain lead but are compliant with EU RoHS pursuant to a specific EU RoHS exemption.

Green: TI defines "Green" to mean the content of Chlorine (Cl) and Bromine (Br) based flame retardants meet JS709B low halogen requirements of <=1000ppm threshold. Antimony trioxide based flame retardants must also meet the <=1000ppm threshold requirement.

(3) MSL, Peak Temp. - The Moisture Sensitivity Level rating according to the JEDEC industry standard classifications, and peak solder temperature.

(4) There may be additional marking, which relates to the logo, the lot trace code information, or the environmental category on the device.

(5) Multiple Device Markings will be inside parentheses. Only one Device Marking contained in parentheses and separated by a "~" will appear on a device. If a line is indented then it is a continuation of the previous line and the two combined represent the entire Device Marking for that device.

(6) Lead finish/Ball material - Orderable Devices may have multiple material finish options. Finish options are separated by a vertical ruled line. Lead finish/Ball material values may wrap to two lines if the finish value exceeds the maximum column width.

Important Information and Disclaimer: The information provided on this page represents TI's knowledge and belief as of the date that it is provided. TI bases its knowledge and belief on information provided by third parties, and makes no representation or warranty as to the accuracy of such information. Efforts are underway to better integrate information from third parties. TI has taken and

continues to take reasonable steps to provide representative and accurate information but may not have conducted destructive testing or chemical analysis on incoming materials and chemicals. TI and TI suppliers consider certain information to be proprietary, and thus CAS numbers and other limited information may not be available for release.

In no event shall TI's liability arising out of such information exceed the total purchase price of the TI part(s) at issue in this document sold by TI to Customer on an annual basis.

TUBE

*All dimensions are nominal

Device	Package Name	Package Type	Pins	SPQ	L (mm)	W (mm)	T (μm)	B (mm)
DAC716PB	N	PDIP	16	25	506	13.97	11230	4.32
DAC716PK	N	PDIP	16	25	506	13.97	11230	4.32
DAC716UB	DW	SOIC	16	40	507	12.83	5080	6.6
DAC716UK	DW	SOIC	16	40	507	12.83	5080	6.6

IMPORTANT NOTICE AND DISCLAIMER

TI PROVIDES TECHNICAL AND RELIABILITY DATA (INCLUDING DATA SHEETS), DESIGN RESOURCES (INCLUDING REFERENCE DESIGNS), APPLICATION OR OTHER DESIGN ADVICE, WEB TOOLS, SAFETY INFORMATION, AND OTHER RESOURCES "AS IS" AND WITH ALL FAULTS, AND DISCLAIMS ALL WARRANTIES, EXPRESS AND IMPLIED, INCLUDING WITHOUT LIMITATION ANY IMPLIED WARRANTIES OF MERCHANTABILITY, FITNESS FOR A PARTICULAR PURPOSE OR NON-INFRINGEMENT OF THIRD PARTY INTELLECTUAL PROPERTY RIGHTS.

These resources are intended for skilled developers designing with TI products. You are solely responsible for (1) selecting the appropriate TI products for your application, (2) designing, validating and testing your application, and (3) ensuring your application meets applicable standards, and any other safety, security, regulatory or other requirements.

These resources are subject to change without notice. TI grants you permission to use these resources only for development of an application that uses the TI products described in the resource. Other reproduction and display of these resources is prohibited. No license is granted to any other TI intellectual property right or to any third party intellectual property right. TI disclaims responsibility for, and you will fully indemnify TI and its representatives against, any claims, damages, costs, losses, and liabilities arising out of your use of these resources.

TI's products are provided subject to [TI's Terms of Sale](#) or other applicable terms available either on ti.com or provided in conjunction with such TI products. TI's provision of these resources does not expand or otherwise alter TI's applicable warranties or warranty disclaimers for TI products.

TI objects to and rejects any additional or different terms you may have proposed.

Mailing Address: Texas Instruments, Post Office Box 655303, Dallas, Texas 75265
Copyright © 2022, Texas Instruments Incorporated