

DS26LS31MQML Quad High Speed Differential Line Driver

Check for Samples: [DS26LS31MQML](#)

FEATURES

- Operation from Single 5V Supply
- Outputs Won't Load Line When $V_{CC} = 0V$
- Four Line Drivers in One Package for Maximum Package Density
- Output Short-Circuit Protection
- Complementary Outputs
- Meets the Requirements of EIA Standard RS-422
- Pin Compatible with AM26LS31
- Glitch Free Power Up/Down

DESCRIPTION

The DS26LS31MQML is a quad differential line driver designed for digital data transmission over balanced lines. The DS26LS31MQML meets all the requirements of EIA Standard RS-422 and Federal Standard 1020. It is designed to provide unipolar differential drive to twisted-pair or parallel-wire transmission lines.

The circuit provides an enable and disable function common to all four drivers. The DS26LS31MQML features TRI-STATE outputs and logically ANDed complementary outputs. The inputs are all LS compatible and are all one unit load.

The DS26LS31 features a power up/down protection circuit which keeps the output in a high impedance state (TRI-STATE) during power up or down preventing erroneous glitches on the transmission lines.

Logic and Connection Diagrams

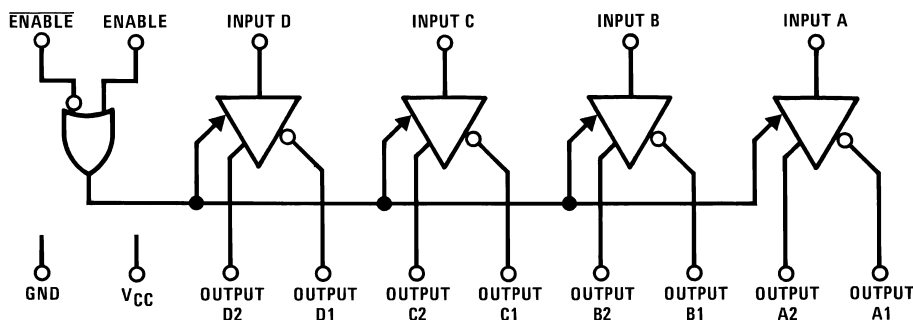

Please be aware that an important notice concerning availability, standard warranty, and use in critical applications of Texas Instruments semiconductor products and disclaimers thereto appears at the end of this data sheet.

All trademarks are the property of their respective owners.

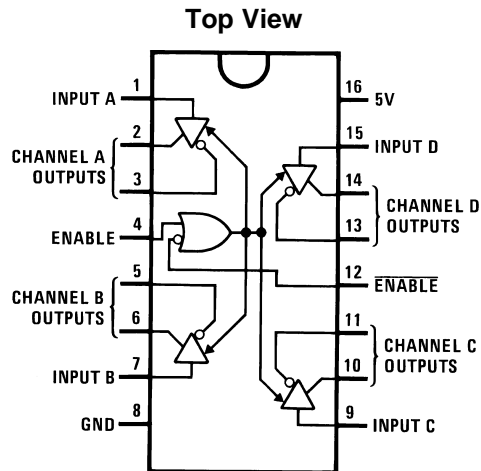

Figure 1. CDIP Package
See Package Numbers NAJ0020A, NFE0016A, NAD0016A



These devices have limited built-in ESD protection. The leads should be shorted together or the device placed in conductive foam during storage or handling to prevent electrostatic damage to the MOS gates.

Absolute Maximum Ratings⁽¹⁾

Supply Voltage	7V
Input Voltage	7V
Output Voltage	5.5V
Output Voltage (Power OFF)	-0.25 to 6V
Maximum Power Dissipation at 25°C ⁽²⁾	
NFE0016A Package	1400 mW
NAJ0020A Package	1600 mW
NAD0016A Package	850 mW
Junction Temperature (T _J)	+150°C
Thermal Resistance, Junction-to-Ambient θ _{JA}	
NFE0016A Package	94°C/W derate above +25°C at 10.6 mW/°C
NAJ0020A Package	83°C/W derate above +25°C at 12 mW/°C
NAD0016A Package	163°C/W derate above +25°C at 6.1 mW/°C
Thermal Resistance, Junction-to-Case θ _{JC}	
NFE0016A Package	16°C/W
NAJ0020A Package	19°C/W
NAD0016A Package	14°C/W
ESD Tolerance	2500V

- (1) "Absolute Maximum Ratings" are those values beyond which the safety of the device cannot be specified. They are not meant to imply that the devices should be operated at these limits. The tables of "Electrical Characteristics" provide conditions for actual device operation.
- (2) Derate CDIP = 11.5 mW/°C, LCCC = 13mW/°C, CLGA = 7.4mW/°C above 25°C.

Recommended Operating Conditions

Supply Voltage, V _{CC}	4.5 V to 5.5 V
Temperature, T _A	-55°C to +125°C

Radiation Features

DS26LS31MEFQML	300 Krads (Si)
DS26LS31MJFQML	300 Krads (Si)
DS26LS31MJFQMLV	300 Krads (Si)
DS26LS31MWFQML	300 Krads (Si)
DS26LS31MWFQMLV	300 Krads (Si)

Quality Conformance Inspection

MIL-STD-883, Method 5005 - Group A

Subgroup	Description	Temp (°C)
1	Static tests at	+25
2	Static tests at	+125
3	Static tests at	-55
4	Dynamic tests at	+25
5	Dynamic tests at	+125
6	Dynamic tests at	-55
7	Functional tests at	+25
8A	Functional tests at	+125
8B	Functional tests at	-55
9	Switching tests at	+25
10	Switching tests at	+125
11	Switching tests at	-55

DS26LS31M - SMD, QMLV & RH Electrical Characteristics DC Parameters

 The following conditions apply, unless otherwise specified. +V = 5V, V_{CM} = 0V.⁽¹⁾

Parameter		Test Conditions	Notes	Min	Max	Unit	Sub-groups
V _{IH}	Logical "1" Input Voltage	V _{CC} = 4.5V	See and ⁽²⁾ (3)	2		V	1, 2, 3
V _{IL}	Logical "0" Input Voltage	V _{CC} = 5.5V	See ⁽²⁾ and (3)		.8	V	1, 2, 3
V _{OH}	Logical "1" Output Voltage	V _{CC} = 4.5V, I _{OH} = -20mA	See ⁽³⁾	2.5		V	1, 2, 3
V _{OL}	Logical "0" Output Voltage	V _{CC} = 4.5V, I _{OL} = 20mA	See ⁽³⁾		.5	V	1, 2, 3
I _{IH}	Logical "1" Input Current	V _{CC} = 5.5V, V _{IN} = 2.7V	See ⁽³⁾	-2.0	20	µA	1, 2, 3
I _{IL}	Logical "0" Input Current	V _{CC} = 5.5V, V _{IN} = .4V	See ⁽³⁾	100	-360	µA	1, 2, 3
I _I	Input Reverse Current	V _{CC} = 5.5V, V _{IN} = 7V	See ⁽³⁾	-.01	.1	mA	1, 2, 3
I _O	TRI-STATE Output Current	V _{CC} = 5.5V, V _O = .5V	See ⁽³⁾		-20	µA	1, 2, 3
		V _{CC} = 5.5V, V _O = 2.5V	See ⁽³⁾		20	µA	1, 2, 3
V _{IC}	Input Clamp Voltage	V _{CC} = 4.5V, I _{IN} = -18mA	See ⁽³⁾		-1.5	V	1, 2, 3
I _{OS}	Output Short Circuit Current	V _{CC} = 5.5V	See ⁽³⁾	-30	-150	mA	1, 2, 3
I _{CC}	Power Supply Current	V _{CC} = 5.5V, All Outputs Disabled or Active	See ⁽³⁾		80	mA	1, 2, 3

- (1) Pre and post irradiation limits are identical to those listed under AC and DC electrical characteristics. These parts may be dose rate sensitive in a space environment and demonstrate enhanced low dose rate effect. Radiation end point limits for the noted parameters are ensured only for the conditions as specified in MIL-STD 883, Method 1019, Condition A.
- (2) Parameter tested go-no-go only.
- (3) Subgroups 1, 2 and 9, 10: Power dissipation must be externally controlled at elevated temperatures.

DS26LS31M - SMD, QMLV and RH Electrical Characteristics AC Parameters - Propagation Delay Time

The following conditions apply, unless otherwise specified. $V_{CC} = 5V$, $V_{IN} = 1.3V$ to $V_O = 1.3V$, V (pulse) = 0 to 3V.⁽¹⁾

Parameter		Test Conditions	Notes	Min	Max	Unit	Sub-groups
t _{PLH}	Input to Output	C _L = 30 pF	See ⁽²⁾		20	ns	9
					30	ns	10, 11
t _{PHL}	Input to Output	C _L = 30 pF	See ⁽²⁾		20	ns	9
					30	ns	10, 11
t _{Skew}	Output to Output	C _L = 30 pF	See ⁽²⁾		6	ns	9
					9	ns	10, 11
t _{PLZ}	Enable to Output	S2 Open, Enable, C _L = 10 pF	See ⁽²⁾		35	ns	9
					53	ns	10, 11
		S2 Open, $\overline{\text{Enable}}$, C _L = 10 pF	See ⁽²⁾		35	ns	9
					53	ns	10, 11
t _{PHZ}	Enable to Output	S1 Open, Enable, C _L = 10 pF	See ⁽²⁾		30	ns	9
					45	ns	10, 11
		S1 Open, $\overline{\text{Enable}}$, C _L = 10 pF	See ⁽²⁾		30	ns	9
					45	ns	10, 11
t _{PZL}	Enable to Output	S2 Open, Enable, C _L = 30 pF	See ⁽²⁾		45	ns	9
					68	ns	10, 11
		S2 Open, $\overline{\text{Enable}}$, C _L = 30 pF	See ⁽²⁾		45	ns	9
					68	ns	10, 11
t _{PZH}	Enable to Output	S1 Open, Enable, C _L = 30 pF	See ⁽²⁾		40	ns	9
					60	ns	10, 11
		S1 Open, $\overline{\text{Enable}}$, C _L = 30 pF	See ⁽²⁾		40	ns	9
					60	ns	10, 11

(1) Pre and post irradiation limits are identical to those listed under AC and DC electrical characteristics. These parts may be dose rate sensitive in a space environment and demonstrate enhanced low dose rate effect. Radiation end point limits for the noted parameters are ensured only for the conditions as specified in MIL-STD 883, Method 1019, Condition A.

(2) Subgroups 1, 2 and 9, 10: Power dissipation must be externally controlled at elevated temperatures.

DS26LS31M - SMD, QMLV and RH Electrical Characteristics DC Parameters - Drift Values

The following conditions apply, unless otherwise specified. Delta calculations performed on QMLV only devices after burn-in and at Group B5.

Parameter		Test Conditions	Notes	Min	Max	Unit	Sub-groups
V _{OL}	Output Low Voltage	V _{CC} = 4.5, I _{OL} = 20 mA	See ⁽¹⁾	-50	50	mV	1
V _{OH}	Output High Voltage	V _{CC} = 4.5, I _{OH} = -20 mA	See ⁽¹⁾	-250	250	mV	1
I _{CC}	Power Supply Current	V _{CC} = 5.5, All outputs disabled or active	See ⁽¹⁾	-8	8	mA	1

(1) Subgroups 1, 2 and 9, 10: Power dissipation must be externally controlled at elevated temperatures.

DS26LS31M - 883 Electrical Characteristics DC Parameters

Parameter		Test Conditions	Notes	Min	Max	Unit	Sub-groups
V _{IH}	Logical "1" Input Voltage		See ⁽¹⁾ and ⁽²⁾	2		V	1, 2, 3
V _{IL}	Logical "0" Input Voltage		See ⁽¹⁾ and ⁽²⁾		.8	V	1, 2, 3
V _{OH}	Logical "1" Output Voltage	V _{CC} = 4.5V, I _{OH} = -20mA	See ⁽²⁾	2.5		V	1, 2, 3

(1) Parameter tested go-no-go only.

(2) Subgroups 1, 2 and 9, 10: Power dissipation must be externally controlled at elevated temperatures.

DS26LS31M - 883 Electrical Characteristics DC Parameters (continued)

Parameter		Test Conditions	Notes	Min	Max	Unit	Sub-groups
V_{OL}	Logical "0" Output Voltage	$V_{CC} = 4.5V, I_{OL} = 20mA$	See ⁽²⁾		.5	V	1, 2, 3
I_{IH}	Logical "1" Input Current	$V_{CC} = 5.5V, V_{IN} = 2.7V$	See ⁽²⁾		20	uA	1, 2, 3
I_{IL}	Logical "0" Input Current	$V_{CC} = 5.5V, V_{IN} = .4V$	See ⁽²⁾		-200	uA	1, 2, 3
I_I	Input Reverse Current	$V_{CC} = 5.5V, V_{IN} = 7V$	See ⁽²⁾		.1	mA	1, 2, 3
I_O	TRI-STATE Output Current	$V_{CC} = 5.5V, V_O = .5V$	See ⁽²⁾		-20	uA	1, 2, 3
		$V_{CC} = 5.5V, V_O = 2.5V$	See ⁽²⁾		20	uA	1, 2, 3
V_{IC}	Input Clamp Voltage	$V_{CC} = 4.5V, I_{IN} = -18mA$	See ⁽²⁾		-1.5	V	1, 2, 3
$I_{OS} (min)$	Output Short Circuit Current	$V_{CC} = 5.5V$	See ⁽²⁾	-30		mA	1, 2, 3
$I_{OS} (max)$	Output Short Circuit Current	$V_{CC} = 5.5V$	See ⁽²⁾		-150	mA	1, 2, 3
I_{CC}	Power Supply Current	$V_{CC} = 5.5V, \text{All Outputs Disabled or Active}$	See ⁽²⁾		60	mA	1, 2, 3

DS26LS31M - 883 Electrical Characteristics AC Parameters - Propagation Delay Time

The following conditions apply, unless otherwise specified. $V_{CC} = 5V, C_L = 50pF$ or equivalent impedance provided by diode load.

Parameter		Test Conditions	Notes	Min	Max	Unit	Sub-groups
t_{PLH}	Input to Output		See ⁽¹⁾ and ⁽²⁾		15	ns	9
					30	ns	10, 11.
t_{PHL}	Input to Output		See ⁽¹⁾ and ⁽²⁾		15	ns	9
					30	ns	10, 11.
t_{Skew}	Output to Output		See ⁽¹⁾ and ⁽²⁾		6	ns	9
					9	ns	10, 11.
t_{PLZ}	Enable to Output	S2 Open, Enable	See ⁽¹⁾ and ⁽²⁾		35	ns	9
					53	ns	10, 11.
		S2 Open, /Enable	See ⁽¹⁾ and ⁽²⁾		35	ns	9
					53	ns	10, 11.
t_{PHZ}	Enable to Output	S1 Open, Enable	See ⁽¹⁾ and ⁽²⁾		25	ns	9
					45	ns	10, 11.
		S1 Open, /Enable	See ⁽¹⁾ and ⁽²⁾		25	ns	9
					45	ns	10, 11.
t_{PZL}	Enable to Output	S2 Open, Enable	See ⁽¹⁾ and ⁽²⁾		30	ns	9
					68	ns	10, 11.
		S2 Open, /Enable	See ⁽¹⁾ and ⁽²⁾		30	ns	9
					68	ns	10, 11.
t_{PZH}	Enable to Output	S1 Open, Enable	See ⁽¹⁾ and ⁽²⁾		30	ns	9
					60	ns	10, 11.
		S1 Open, /Enable	See ⁽¹⁾ and ⁽²⁾		30	ns	9
					60	ns	10, 11.

(1) Subgroups 1, 2 and 9, 10: Power dissipation must be externally controlled at elevated temperatures.

(2) Subgroup 10 and 11 specified but not tested.

AC TEST CIRCUIT AND SWITCHING TIME WAVEFORMS

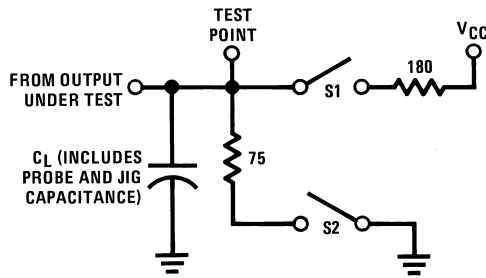

S1 and S2 of load circuit are closed except where shown.

Figure 2. AC Test Circuit

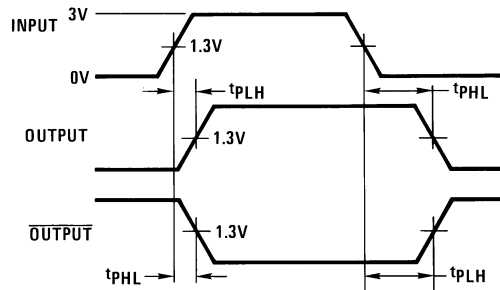

f = 1 MHz, $t_r \leq 15$ ns, $t_f \leq 6$ ns

Figure 3. Propagation Delays

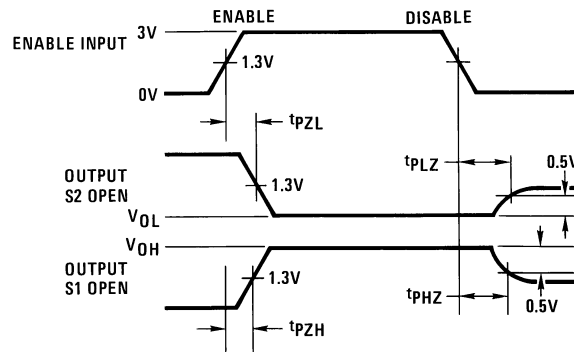

f = 1 MHz, $t_r \leq 15$ ns, $t_f \leq 6$ ns

Figure 4. Enable and Disable Times

TYPICAL APPLICATIONS

Figure 5. Two-Wire Balanced System, RS-422

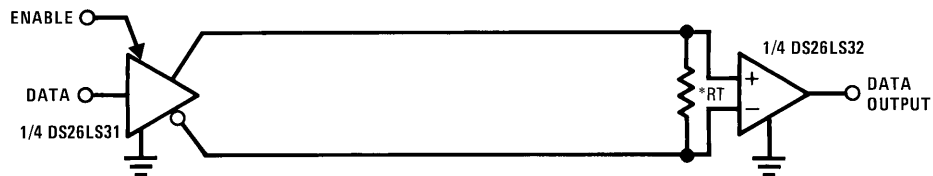

R_T is optional although highly recommended to reduce reflection.

Typical Performance Characteristics

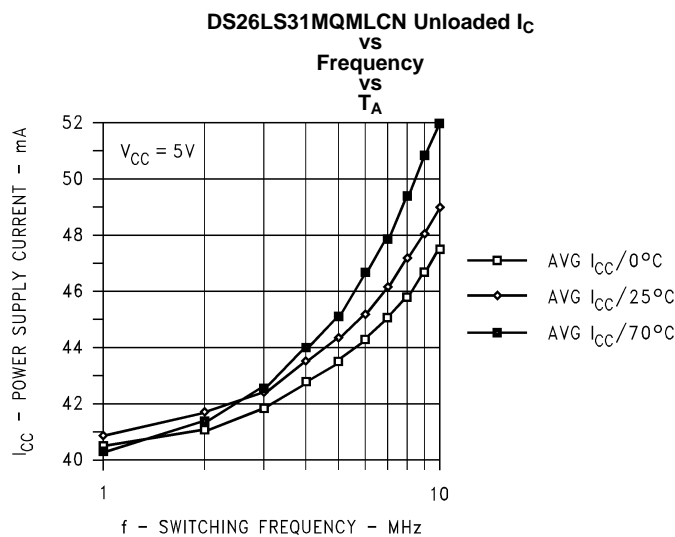

Figure 6.

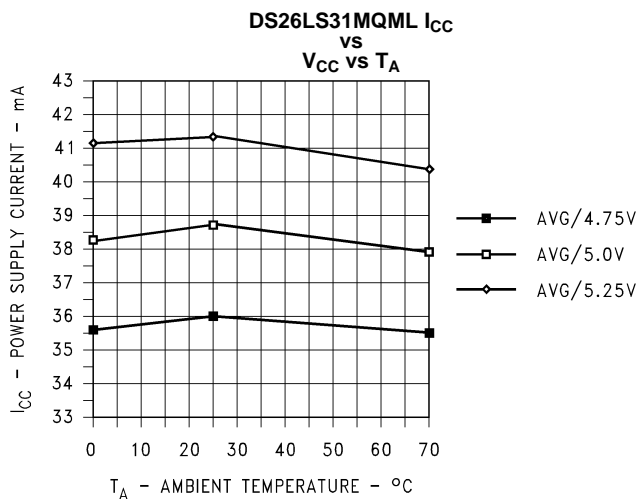

Figure 7.

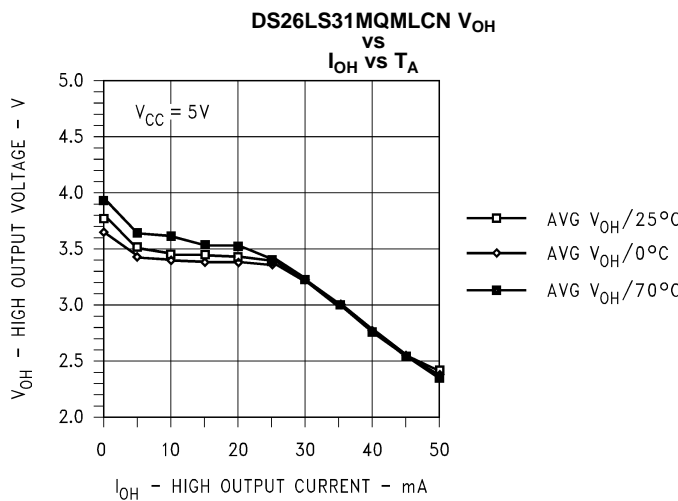

Figure 8.

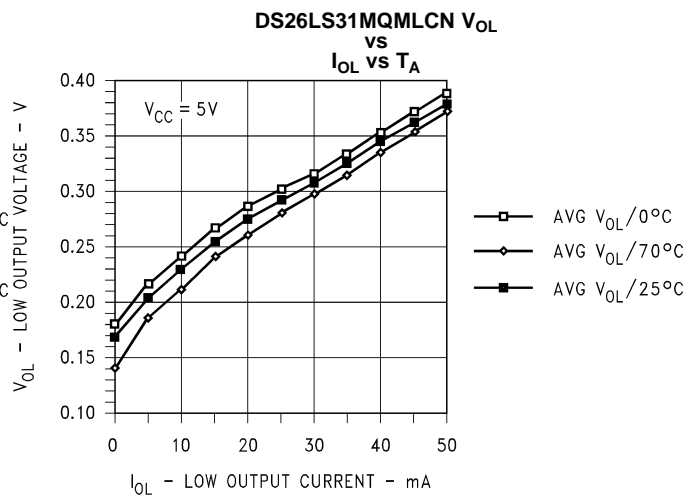

Figure 9.

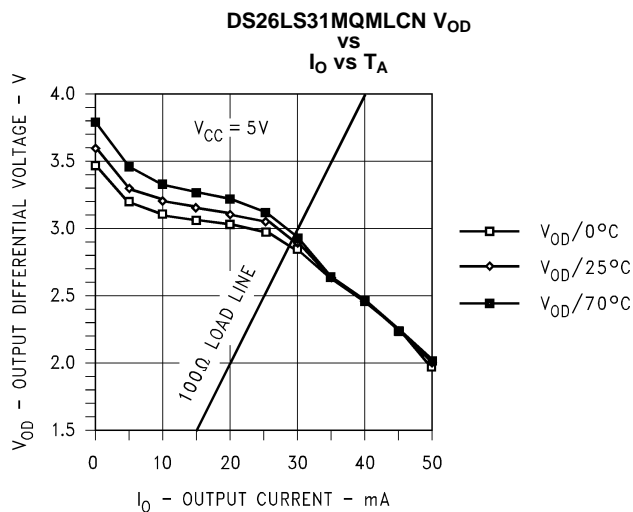







Figure 10.

REVISION HISTORY

Date Released	Revision	Section	Originator	Changes
8/04/05	A	New Release, Corporate format Ordering Info. Table, Absolute Ratings, Maximum Operating Conditions, New Radiation Section. Typos in QMLV & RH, 883 AC Electrical Characteristics Parameters Column	R. Malone	2 MDS data sheets converted into a Corp. data sheet format. Following MDS data sheets will be Archived MDDS26LS31M-X-RH, Rev.2A0, MNDS26LS31M-X, Rev. 0A0
3/01/06	A1		R. Malone	Added: Junction temp., Thermal Resistance θ_{JA} and θ_{JC} . Added a Radiation Section. Changed: Maximum Operating Conditions to Recommended Operating Conditions, Enable and Disable Time to Enable to Output. Revision A will be archived.
4/15/2013	B		TIS	Changed layout of National Data Sheet to TI format

PACKAGING INFORMATION

Orderable Device	Status (1)	Package Type	Package Drawing	Pins	Package Qty	Eco Plan (2)	Lead finish/ Ball material (6)	MSL Peak Temp (3)	Op Temp (°C)	Device Marking (4/5)	Samples
AM26LS31MW/883	ACTIVE	CFP	NAD	16	19	Non-RoHS & Green	Call TI	Level-1-NA-UNLIM	-55 to 125	DS26LS31MW /883 Q ACO /883 Q >T	
DS26LS31ME-SMD	ACTIVE	LCCC	NAJ	20	50	RoHS-Exempt & Green	Call TI	Level-1-NA-UNLIM	-55 to 125	DS26LS31ME -SMD Q 5962-78023 01Q2A ACO 01Q2A >T	
DS26LS31MJ-SMD	ACTIVE	CDIP	NFE	16	25	Non-RoHS & Green	Call TI	Level-1-NA-UNLIM	-55 to 125	DS26LS31MJ-SMD 5962-7802301MEA Q	
DS26LS31MJ/883	ACTIVE	CDIP	NFE	16	25	Non-RoHS & Green	Call TI	Level-1-NA-UNLIM	-55 to 125	DS26LS31MJ/883 Q	
DS26LS31MW/883	ACTIVE	CFP	NAD	16	19	Non-RoHS & Green	Call TI	Level-1-NA-UNLIM	-55 to 125	DS26LS31MW /883 Q ACO /883 Q >T	

(1) The marketing status values are defined as follows:

ACTIVE: Product device recommended for new designs.

LIFEBUY: TI has announced that the device will be discontinued, and a lifetime-buy period is in effect.

NRND: Not recommended for new designs. Device is in production to support existing customers, but TI does not recommend using this part in a new design.

PREVIEW: Device has been announced but is not in production. Samples may or may not be available.

OBSOLETE: TI has discontinued the production of the device.

(2) **RoHS:** TI defines "RoHS" to mean semiconductor products that are compliant with the current EU RoHS requirements for all 10 RoHS substances, including the requirement that RoHS substance do not exceed 0.1% by weight in homogeneous materials. Where designed to be soldered at high temperatures, "RoHS" products are suitable for use in specified lead-free processes. TI may reference these types of products as "Pb-Free".

RoHS Exempt: TI defines "RoHS Exempt" to mean products that contain lead but are compliant with EU RoHS pursuant to a specific EU RoHS exemption.

Green: TI defines "Green" to mean the content of Chlorine (Cl) and Bromine (Br) based flame retardants meet JS709B low halogen requirements of <=1000ppm threshold. Antimony trioxide based flame retardants must also meet the <=1000ppm threshold requirement.

(3) MSL, Peak Temp. - The Moisture Sensitivity Level rating according to the JEDEC industry standard classifications, and peak solder temperature.

(4) There may be additional marking, which relates to the logo, the lot trace code information, or the environmental category on the device.

(5) Multiple Device Markings will be inside parentheses. Only one Device Marking contained in parentheses and separated by a "-" will appear on a device. If a line is indented then it is a continuation of the previous line and the two combined represent the entire Device Marking for that device.

(6) Lead finish/Ball material - Orderable Devices may have multiple material finish options. Finish options are separated by a vertical ruled line. Lead finish/Ball material values may wrap to two lines if the finish value exceeds the maximum column width.

Important Information and Disclaimer:The information provided on this page represents TI's knowledge and belief as of the date that it is provided. TI bases its knowledge and belief on information provided by third parties, and makes no representation or warranty as to the accuracy of such information. Efforts are underway to better integrate information from third parties. TI has taken and continues to take reasonable steps to provide representative and accurate information but may not have conducted destructive testing or chemical analysis on incoming materials and chemicals. TI and TI suppliers consider certain information to be proprietary, and thus CAS numbers and other limited information may not be available for release.

In no event shall TI's liability arising out of such information exceed the total purchase price of the TI part(s) at issue in this document sold by TI to Customer on an annual basis.

TUBE

*All dimensions are nominal

Device	Package Name	Package Type	Pins	SPQ	L (mm)	W (mm)	T (μm)	B (mm)
AM26LS31MW/883	NAD	CFP	16	19	502	23	9398	9.78
DS26LS31ME-SMD	NAJ	LCCC	20	50	470	11	3810	0
DS26LS31MJ-SMD	NFE	CDIP	16	25	502	14	10668	4.32
DS26LS31MJ/883	NFE	CDIP	16	25	502	14	10668	4.32
DS26LS31MW/883	NAD	CFP	16	19	502	23	9398	9.78

NFE0016A

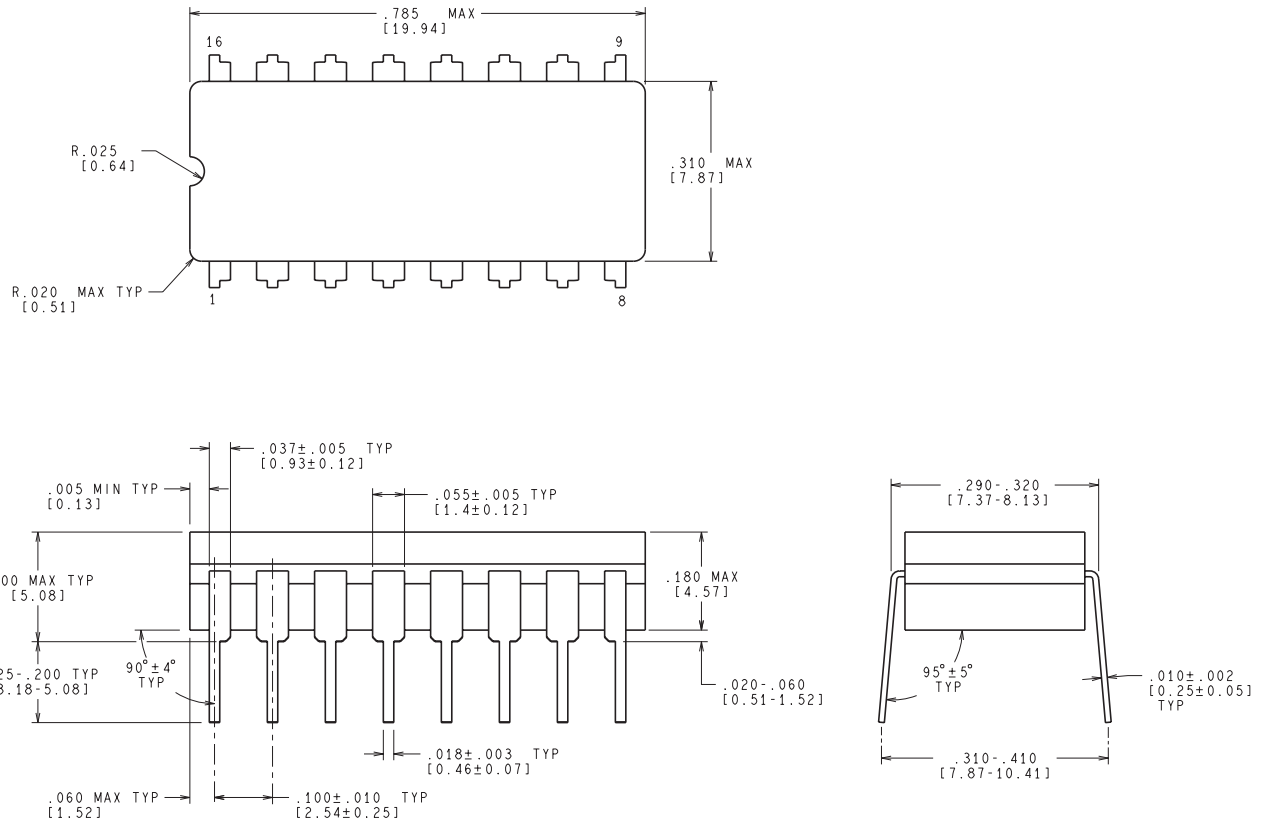

CONTROLLING DIMENSION IS INCH
VALUES IN [] ARE MILLIMETERS

J16A (REV L)

NAD0016A

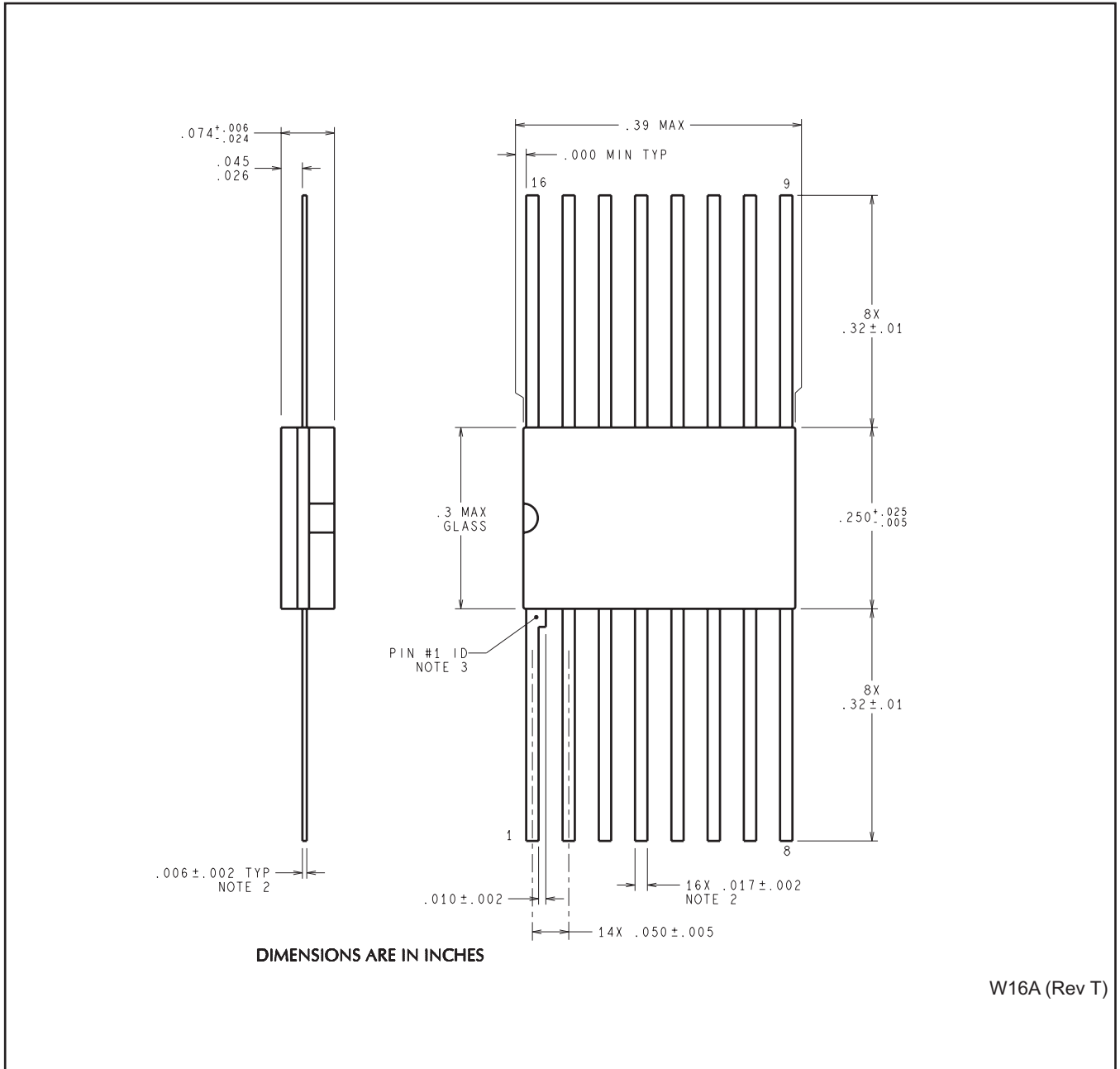

NAJ0020A

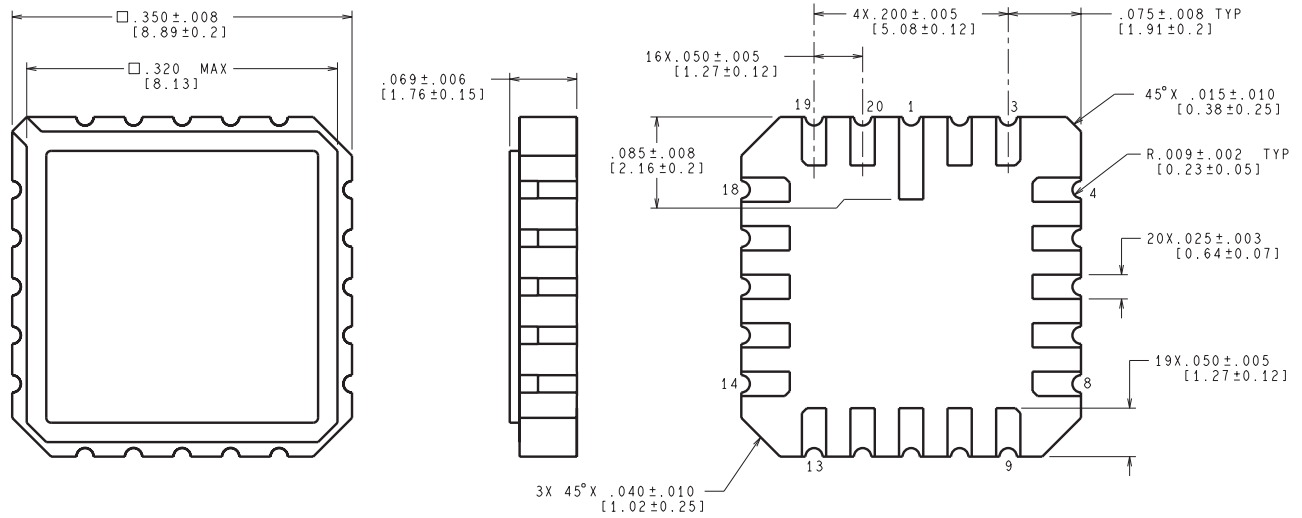

CONTROLLING DIMENSION IS INCH
VALUES IN [] ARE MILLIMETERS

E20A (Rev F)

IMPORTANT NOTICE AND DISCLAIMER

TI PROVIDES TECHNICAL AND RELIABILITY DATA (INCLUDING DATA SHEETS), DESIGN RESOURCES (INCLUDING REFERENCE DESIGNS), APPLICATION OR OTHER DESIGN ADVICE, WEB TOOLS, SAFETY INFORMATION, AND OTHER RESOURCES "AS IS" AND WITH ALL FAULTS, AND DISCLAIMS ALL WARRANTIES, EXPRESS AND IMPLIED, INCLUDING WITHOUT LIMITATION ANY IMPLIED WARRANTIES OF MERCHANTABILITY, FITNESS FOR A PARTICULAR PURPOSE OR NON-INFRINGEMENT OF THIRD PARTY INTELLECTUAL PROPERTY RIGHTS.

These resources are intended for skilled developers designing with TI products. You are solely responsible for (1) selecting the appropriate TI products for your application, (2) designing, validating and testing your application, and (3) ensuring your application meets applicable standards, and any other safety, security, regulatory or other requirements.

These resources are subject to change without notice. TI grants you permission to use these resources only for development of an application that uses the TI products described in the resource. Other reproduction and display of these resources is prohibited. No license is granted to any other TI intellectual property right or to any third party intellectual property right. TI disclaims responsibility for, and you will fully indemnify TI and its representatives against, any claims, damages, costs, losses, and liabilities arising out of your use of these resources.

TI's products are provided subject to [TI's Terms of Sale](#) or other applicable terms available either on ti.com or provided in conjunction with such TI products. TI's provision of these resources does not expand or otherwise alter TI's applicable warranties or warranty disclaimers for TI products.

TI objects to and rejects any additional or different terms you may have proposed.

Mailing Address: Texas Instruments, Post Office Box 655303, Dallas, Texas 75265
Copyright © 2022, Texas Instruments Incorporated