

TPS566250 具有 V_{ID} 控制的 4.5V 至 17V 输入、6A 同步降压转换器

1 特性

- 针对低占空比应用进行优化的集成场效应管 (FET)
 - 44m Ω (高侧) 和 23m Ω (低侧)
- 输出电压范围: 0.6V 至 1.87V (反馈电压步长为 5.5mV)
- 具有多字节接口的 V_{ID} 控制, 支持回读功能
- 25°C 温度下, V_{ID} 控制为 $\pm 1\%$ 输出电压 (12V V_{IN} /1.1V V_{OUT} 时)
- D-CAP2™ 控制模式
- 高级 Eco-mode™ 模式, 以在轻负载时实现高效率 and 低输出电压纹波
- 650kHz 开关频率
- 固定软启动时间: 1ms
- 单调预偏置软启动
- 用于过载保护的断续定时器

2 应用

- 面向消费类应用的媒体处理器: 数字电视、机顶盒
- 系统片上电源
- 高密度配电系统

3 说明

TPS566250 是一款同步降压转换器, 可帮助系统设计人员通过经济高效、低元件数、低待机电流的解决方案来实现一整套终端设备电源总线稳压器。

初始上电之后, 可通过 I²C 兼容 V_{ID} 控制总线向集成电路 (IC) 发送代码来更改输出电压。

TPS566250 的主控制环路采用 D-CAP2™ 模式控制, 无需外部补偿元件即可实现快速瞬态响应。自适应导通时间控制可使器件在高负载条件下的脉宽调制 (PWM) 模式与轻负载条件下的高级 Eco-mode™ 工作模式之间实现无缝切换。高级 Eco-mode™ 使 TPS566250 能够在轻负载条件下保持高效率。TPS566250 既能够适应诸如高分子有机半导体固体电容 (POSCAP) 或高分子聚合物电容 (SP-CAP) 的低等效串联电阻 (ESR) 输出电容, 也能够适应超低等效串联电阻 (ESR) 的陶瓷电容。

该器件提供片上过流、欠压闭锁和热关断保护。

器件信息(1)

器件型号	封装	封装尺寸 (标称值)
TPS566250	HSOP (8)	4.90mm x 3.90mm

(1) 要了解所有可用封装, 请见数据表末尾的可订购产品附录。

4 简化电路原理图

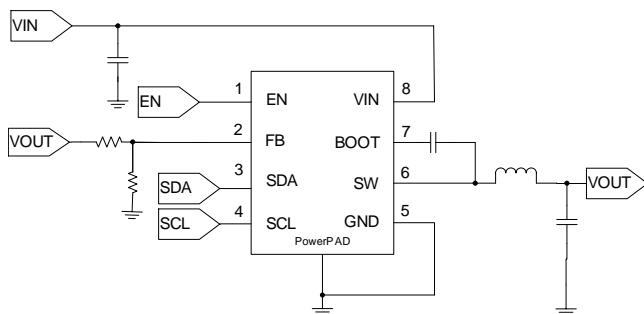

负载瞬态响应

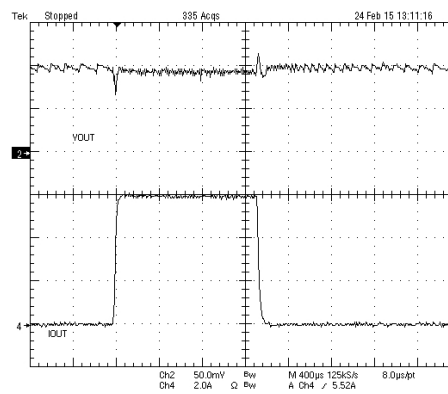

目录

1	特性	1	8.3	Feature Description.....	9
2	应用	1	8.4	Device Functional Modes.....	11
3	说明	1	8.5	Programming.....	11
4	简化电路原理图	1	8.6	Register Maps	13
5	修订历史记录	2	9	Applications and Implementation	16
6	Pin Configuration and Functions	3	9.1	Application Information.....	16
7	Specifications.....	4	9.2	Typical Application	16
7.1	Absolute Maximum Ratings	4	10	Power Supply Recommendations	23
7.2	ESD Ratings.....	4	11	Layout.....	23
7.3	Recommended Operating Conditions.....	4	11.1	Layout Guidelines	23
7.4	Thermal Information	4	11.2	Layout Example	23
7.5	Electrical Characteristics.....	5	12	器件和文档支持	24
7.6	Timing Requirements.....	6	12.1	文档支持	24
7.7	Typical Characteristics.....	7	12.2	商标	24
8	Detailed Description	9	12.3	静电放电警告.....	24
8.1	Overview	9	12.4	术语表	24
8.2	Functional Block Diagram	9	13	机械封装和可订购信息	24
			13.1	热性能信息	24

5 修订历史记录

Changes from Original (March 2015) to Revision A

Page

- Changed the $V_{(FB)}$ MIN value From: -2% to -1.6% in the *Electrical Characteristics* **5**
- Added Test Condition: " $T_A = 0^{\circ}\text{C}$ to 85°C " to $V_{(FB)}$ in the *Electrical Characteristics* **5**

6 Pin Configuration and Functions

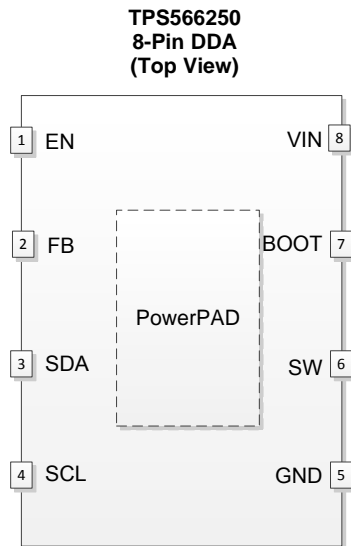

Pin Functions

PIN		I/O	DESCRIPTION
NAME	NO.		
BOOT	7	I/O	Supply input for high-side NFET gate drive circuit. Connect 0.1- μ F ceramic capacitor between VBST and SW pins.
EN	1	I	Enable input control. Pull High to enable converter.
FB	2	I	Converter feedback input. Connect to output voltage with resistor divider.
GND	5	–	Power ground
SCL	4	I/O	Clock I/O terminal.
SDA	3	I/O	Data I/O terminal.
SW	6	I/O	Switch node connections for both the high-side NFET and low-side NFET.
VIN	8	I	Input voltage supply pin.
PowerPAD™	–	–	Thermal pad of the package. Must be soldered down to operate normally and achieve appropriate power dissipation. Connect sensitive FB returns to GND at a single point.

7 Specifications

7.1 Absolute Maximum Ratings

 over operating free-air temperature range (unless otherwise noted) ⁽¹⁾ ⁽²⁾

		MIN	MAX	UNIT
Input voltage range	VIN, EN	-0.3	19	V
	BOOT	-0.3	25	
	BOOT (10ns transient)	-0.3	27	
	BOOT (vs SW)	-0.3	6.5	
	FB, SDA, SCL	-0.3	3.6	
	SW	-2	19	
	SW (10ns transient)	-3.5	21	
Operating Junction temperature, T _J		-40	150	°C
Storage temperature, T _{STG}		-55	150	°C

(1) These are stress ratings only, which do not imply functional operation of the device at these or any other conditions beyond those indicated under Recommended Operating Conditions.

(2) All voltages are with respect to IC GND terminal.

7.2 ESD Ratings

		VALUE	UNIT
V _(ESD) Electrostatic discharge	Human-body model (HBM), per ANSI/ESDA/JEDEC JS-001 ⁽¹⁾	±2000	V
	Charged-device model (CDM), per JEDEC specification JESD22-C101 ⁽²⁾	±500	

(1) JEDEC document JEP155 states that 500-V HBM allows safe manufacturing with a standard ESD control process.

(2) JEDEC document JEP157 states that 250-V CDM allows safe manufacturing with a standard ESD control process.

7.3 Recommended Operating Conditions

over operating free-air temperature range (unless otherwise noted)

		MIN	MAX	UNIT	
V _{IN}	Supply input voltage range	4.5	17	V	
	Input voltage range	BOOT	-0.1		23
		BOOT (10 ns transient)	-0.1		26
		BOOT (vs SW)	-0.1		6
		EN	-0.1		17
		FB, SDA, SCL	-0.1		3.3
		SW	-1.8		17
		SW (10 ns transient)	-3.5		20
T _J	Operating junction temperature range	-40	150	°C	

7.4 Thermal Information

THERMAL METRIC ⁽¹⁾		TPS566250	UNIT
		DDA (8)	
R _{θJA}	Junction-to-ambient thermal resistance	42.1	°C/W
R _{θJctop}	Junction-to-case (top) thermal resistance	55.7	
R _{θJB}	Junction-to-board thermal resistance	24.9	
ψ _{JT}	Junction-to-top characterization parameter	9.5	
ψ _{JB}	Junction-to-board characterization parameter	24.9	
R _{θJcbot}	Junction-to-case (bottom) thermal resistance	3.5	

(1) For more information about traditional and new thermal metrics, see the *IC Package Thermal Metrics* application report, [SPRA953](#).

7.5 Electrical Characteristics

Over operating junction temperature range, $V_{IN} = 12\text{ V}$ (Unless otherwise noted)

PARAMETER		CONDITIONS	MIN	TYP	MAX	UNIT
SUPPLY VOLTAGE						
I_{IN}	VIN supply current	$T_A = 25^\circ\text{C}$, EN = 5 V, FB = 0.7 V (non switching)		450	525	μA
$I_{(VINSDN)}$	VIN shutdown current	$T_A = 25^\circ\text{C}$, EN = 0 V		6.5	10	μA
LOGIC THRESHOLD						
$V_{(ENH)}$	EN H-level threshold voltage			1.1	1.6	V
$V_{(ENL)}$	EN L-level threshold voltage		0.6	0.94		V
	Hysteresis			160		mV
$R_{(EN)}$	EN pin resistance to GND	$V_{(EN)} = 12\text{ V}$	225	350	800	k Ω
FEEDBACK VOLTAGE						
$V_{(FB)}$	FB voltage	$T_A = 0^\circ\text{C}$ to 85°C $V_{OUT} = 1.1\text{ V}$, Upper/lower feedback resistors: 1.37 k Ω / 1.65 k Ω	-1.6%	0	1.6%	
		$T_A = 25^\circ\text{C}$, $V_{OUT} = 1.1\text{ V}$, $I_{OUT} = 10\text{ mA}$, pulse skipping		0.606		V
		$T_A = 25^\circ\text{C}$, $V_{OUT} = 1.1\text{ V}$, continuous current mode	0.594	0.6	0.606	V
MOSFET						
$r_{DS(on)H}$	High side switch resistance	BOOT - SW = 5.5 V		44	74	m Ω
$r_{DS(on)L}$	Low side switch resistance	$V_{IN} = 12\text{ V}$		23	35	m Ω
	Discharge FET			200		Ω
ON-TIME TIMER CONTROL						
f_{sw}	Switching frequency	$L_{OUT} = 1.5\text{ }\mu\text{H}$, $C_{OUT} = 22\text{ }\mu\text{F} \times 2$, $V_{OUT} = 1.1\text{ V}$		650		kHz
CURRENT LIMIT						
I_{OCL}	Valley current limit	$L_{OUT} = 1.5\text{ }\mu\text{H}$, $V_{OUT} = 1.1\text{ V}$, $V_{IN} = 12\text{ V}$	7.6	9.5	11.4	A
	Reverse valley current limit	$L_{OUT} = 1.5\text{ }\mu\text{H}$, $V_{OUT} = 1.1\text{ V}$	1.5	4.5	7	A
OUTPUT UNDERVOLTAGE PROTECTION						
$V_{(UVP)}$	Output UVP trip threshold	UVP detect (H > L)		65%		
THERMAL SHUTDOWN						
T_{SDN}	Thermal shutdown Threshold	Shutdown temperature ⁽¹⁾		165		$^\circ\text{C}$
		Hysteresis ⁽¹⁾		15		$^\circ\text{C}$
UVLO						
UVLO	UVLO Threshold	V_{IN} rising voltage	3.26	3.75	4.05	V
		Hysteresis V_{IN} voltage	0.13	0.33	0.48	V
PGOOD VIA I²C						
$V_{(PGOODTH)}$	PGOOD threshold	FB falling (fault) $V_O = 1.1\text{ V}$		80%		
		FB rising (good) $V_O = 1.1\text{ V}$		85%		
		FB rising (fault) $V_O = 1.1\text{ V}$		125%		
		FB falling (good) $V_O = 1.1\text{ V}$		120%		
SERIAL INTERFACE⁽¹⁾ ⁽²⁾ ⁽³⁾						
V_{IL}	LOW level input voltage				0.6	V
V_{IH}	HIGH level input voltage		1.85			V
V_{hys}	Hysteresis of schmitt trigger inputs		0.11			V
V_{OL}	LOW level output voltage (Open drain, 3 mA sink current)			0.4		V
f_{SCL}	SCL clock frequency			400		kHz
C_b	Capacitive load for each bus line			400		pF

(1) Specified by design. Not production tested.

(2) Refer to [Figure 1](#) for I²C Timing Definitions

(3) C_b = capacitance of bus line in pF

7.6 Timing Requirements

		MIN	TYP	MAX	UNIT		
ON-TIME TIMER CONTROL							
t_{on}	SW On time	$V_{IN} = 12\text{ V}, V_{OUT} = 1.1\text{ V}$		165	ns		
t_{off}	SW Minimum off time	$T_A = 25\text{ }^\circ\text{C}, FB = 0.5\text{ V}$		275	325	ns	
SOFT START							
t_{SS}	Soft start time	Internal soft start time		0.7	1	1.3	ms
OUTPUT UNDERVOLTAGE PROTECTION							
$t_{(UVPDEL)}$	Hiccup delay time (power into short)			1.3		ms	
$t_{(UVPEN)}$	Hiccup off time before restart			10		ms	
SERIAL INTERFACE^{(1) (2) (3)}							
$t_{(SP)}$	Pulse width of spikes suppressed by input filter			32		ns	
$t_{(HD,STA)}$	Hold time (repeated) START condition.			0.6		μs	
t_{LOW}	LOW period of SCL clock			1.3		μs	
t_{HIGH}	HIGH period of SCL clock			0.6		μs	
$t_{(SU,STA)}$	Set-up time for a repeated START condition			0.6		μs	
$t_{(HD,DAT)}$	Data Hold time			50	900	ns	
$t_{(SU,DAT)}$	Data set-up time			100		ns	
t_r	Rise time (SDA or SCL)			$20+0.1C_b^{(3)}$	300	ns	
t_f	Fall time (SDA or SCL)			$20+0.1C_b^{(3)}$	300	ns	
$t_{(SU,STO)}$	Set-up time for STOP condition			0.6		μs	
$t_{(BUF)}$	Bus free time between STOP and START condition			1.3		μs	

- (1) Specified by design. Not production tested.
 (2) Refer to [Figure 1](#) below for I²C Timing Definitions
 (3) C_b = capacitance of bus line in pF

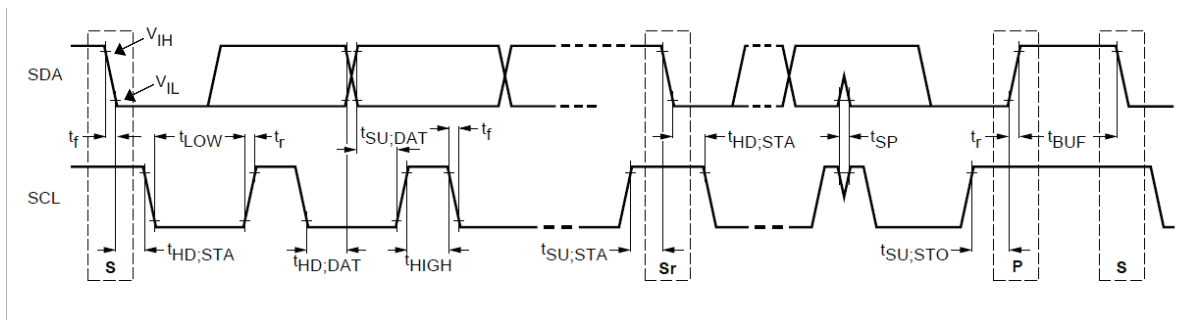

Figure 1. I²C Timing Definitions (reproduced from Phillips I²C spec Version 1.1)

7.7 Typical Characteristics

$V_{IN} = 12\text{ V}$, $T_A = 25\text{ }^\circ\text{C}$, unless otherwise specified.

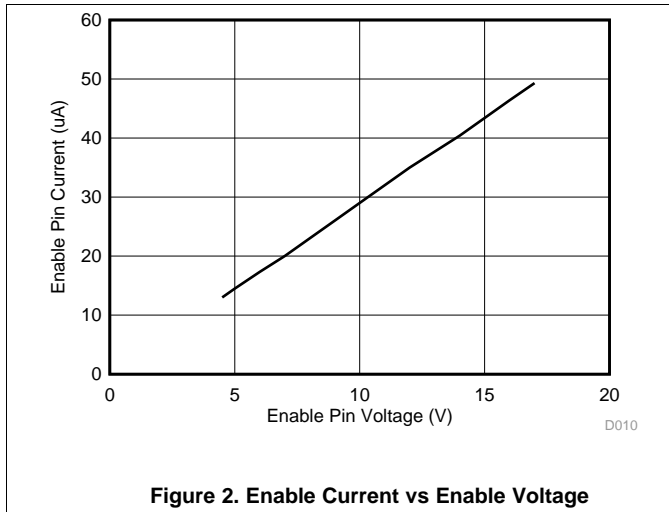

Figure 2. Enable Current vs Enable Voltage

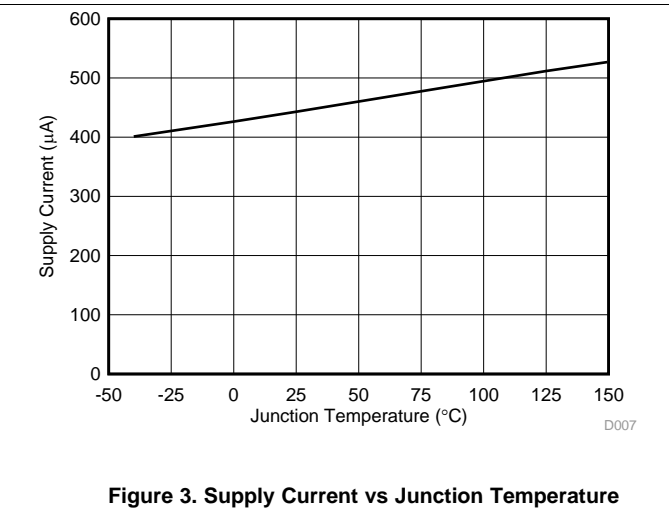

Figure 3. Supply Current vs Junction Temperature

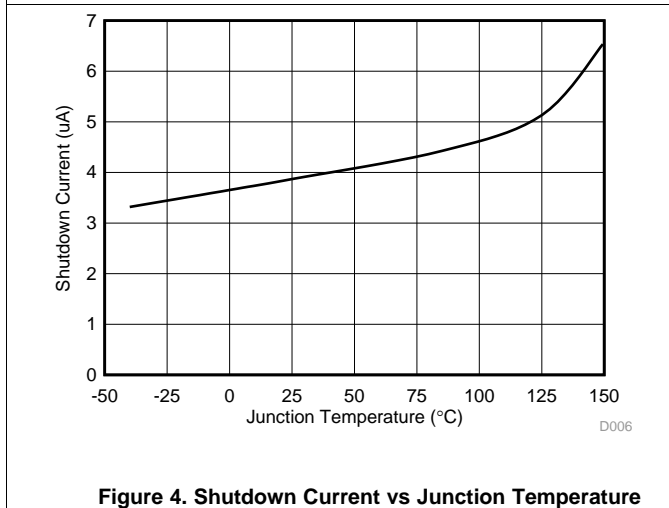

Figure 4. Shutdown Current vs Junction Temperature

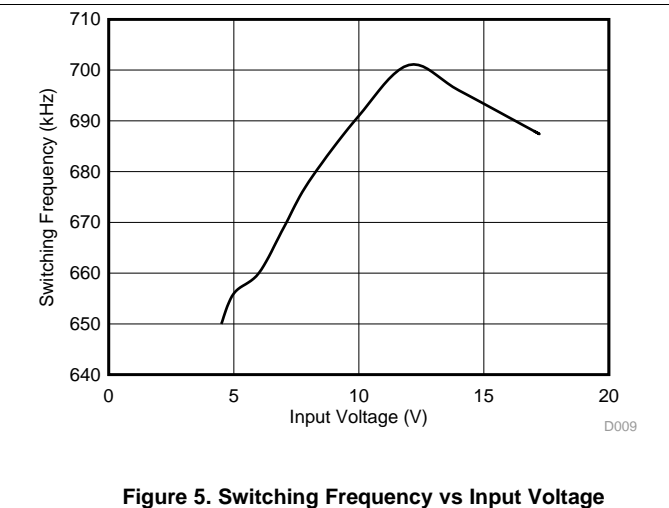

Figure 5. Switching Frequency vs Input Voltage

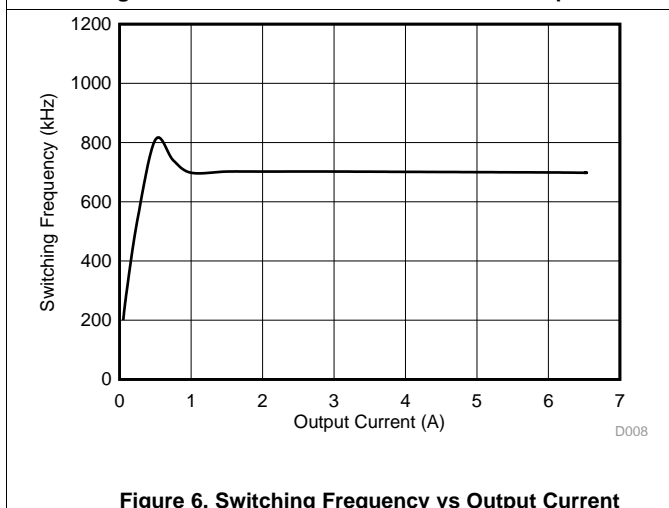

Figure 6. Switching Frequency vs Output Current

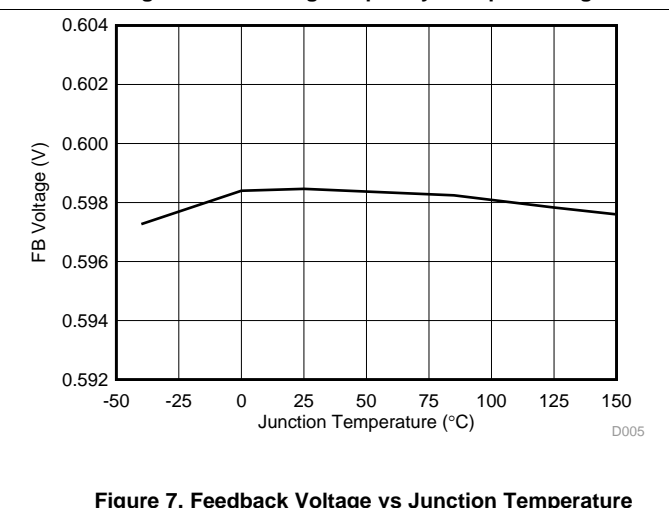

Figure 7. Feedback Voltage vs Junction Temperature

Typical Characteristics (continued)

$V_{IN} = 12\text{ V}$, $T_A = 25\text{ }^\circ\text{C}$, unless otherwise specified.

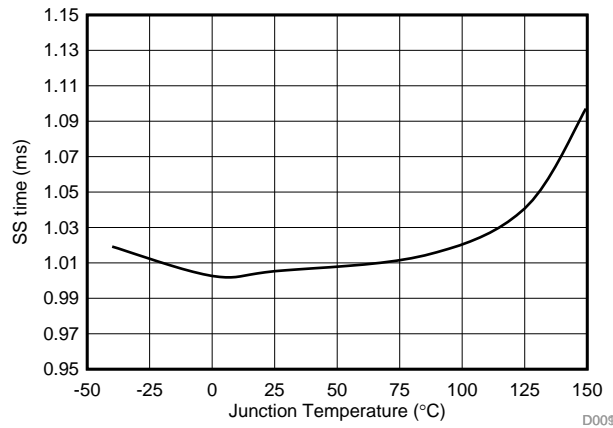

Figure 8. Soft Start Time vs Junction Temperature

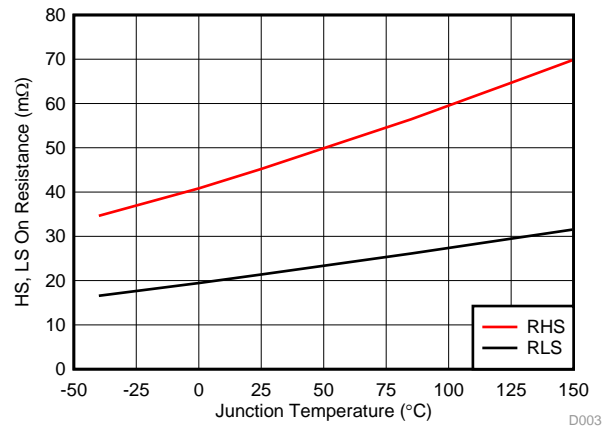

Figure 9. HS and LS $r_{DS(on)}$ vs Junction Temperature

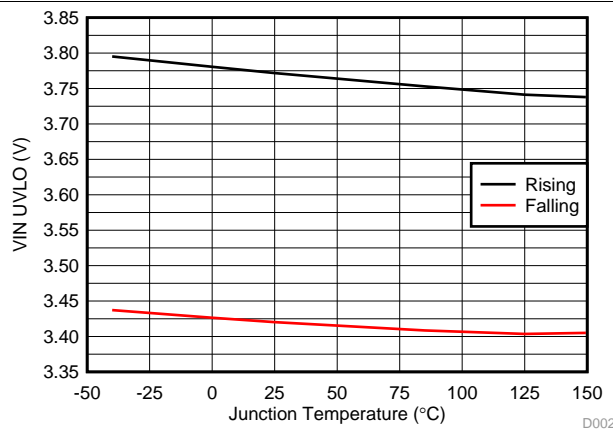

Figure 10. Input Voltage UVLO vs Junction Temperature

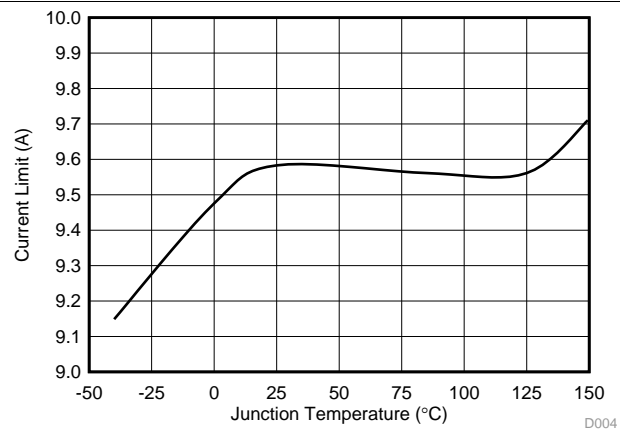

Figure 11. Current Limit vs Junction Temperature

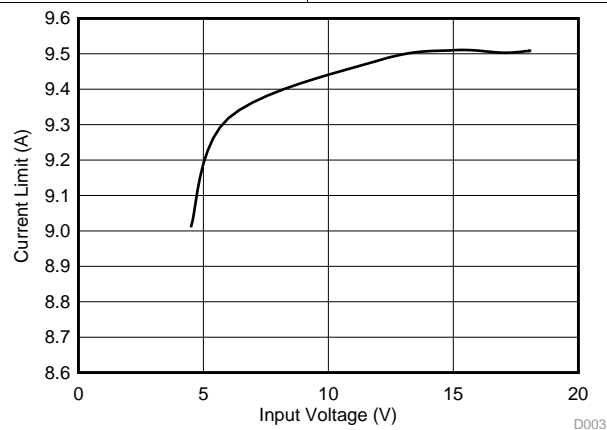

Figure 12. Current Limit vs Input Voltage

8 Detailed Description

8.1 Overview

The TPS566250 is a synchronous step-down (buck) converter with two integrated N-channel MOSFETs for each channel. It operates using D-CAP2™ control mode. The fast transient response of D-CAP2™ control reduces the required output capacitance required to meet a specific level of performance. The output voltage of the device can be set by either FB with divider resistors and I²C compatible interface.

8.2 Functional Block Diagram

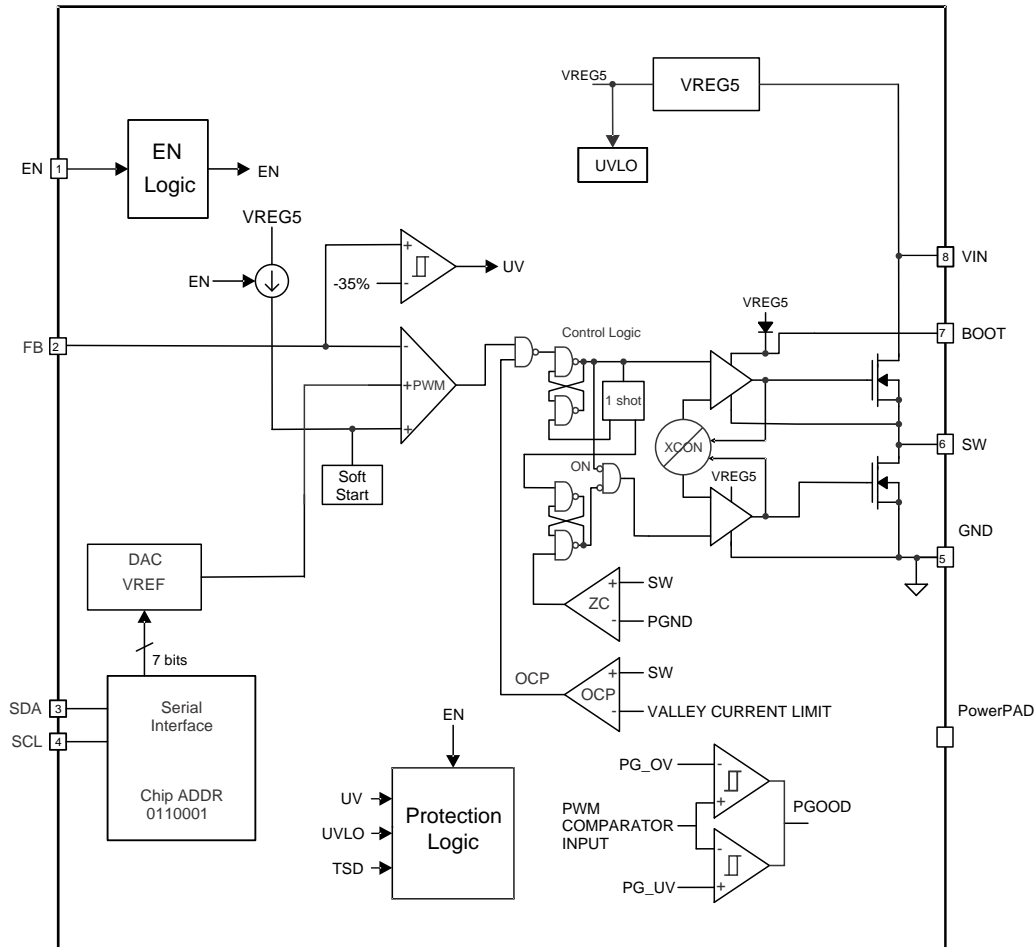

8.3 Feature Description

8.3.1 PWM Operation

The main control loop of the TPS566250 is an adaptive on-time pulse width modulation (PWM) controller that supports a proprietary D-CAP2™ mode control. D-CAP2™ control combines constant on-time control with an internal compensation circuit for pseudo-fixed frequency and low external component count configuration with both low ESR and ceramic output capacitors. It is stable even with virtually no ripple at the output.

At the beginning of each cycle, the high-side MOSFET is turned on. This MOSFET is turned off when the internal timer expires. This timer is set by the converter's input voltage, V_{IN} , and the output voltage, V_{OUT} , to maintain a pseudo-fixed frequency over the input voltage range hence it is called adaptive on-time control. The timer is reset and the high-side MOSFET is turned on again when the feedback voltage falls below the nominal output voltage. An internal ramp is added to the reference voltage to simulate output voltage ripple, eliminating the need for ESR induced output ripple from D-CAP2™ mode control.

Feature Description (continued)

8.3.2 PWM Frequency and Adaptive On-Time Control

TPS566250 uses an adaptive on-time control scheme and does not have a dedicated on board oscillator. The device runs with a pseudo-constant frequency of 650 kHz by using the input voltage and output voltage to set the on-time timer. The on-time is inversely proportional to the input voltage and proportional to the output voltage, therefore, when the duty ratio is V_{OUT}/V_{IN} , the switching frequency is constant.

8.3.3 Soft Start and Pre-Biased Soft Start

The TPS566250 has an internal 1 ms soft-start. When the EN pin becomes high, internal soft-start function begins ramping up the reference voltage to the PWM comparator. The device contains a unique circuit to prevent sinking current from the output during startup if the output is pre-biased. When the soft-start commands a voltage higher than the pre-bias level (internal soft start becomes greater than feedback voltage FB), the controller slowly activates synchronous rectification by starting the first low side FET gate driver pulses with a narrow on-time. It then increments that on-time on a cycle-by-cycle basis until it coincides with the time dictated by (1-D), where D is the duty cycle of the converter. This scheme prevents the initial sinking of the pre-bias output, and ensure that the out voltage (V_{OUT}) starts and ramps up smoothly into regulation and the control loop is given time to transition from output pre-biased startup to normal mode operation.

8.3.4 Overcurrent Protection

The output overcurrent protection (OCP) is implemented using a cycle-by-cycle valley detect control circuit. The switch current is monitored by measuring the low-side FET switch voltage between the SW pin and GND. This voltage is proportional to the switch current. To improve accuracy, the voltage sensing is temperature compensated.

During the on time of the high-side FET switch, the switch current increases at a linear rate determined by V_{IN} , V_{OUT} , the on-time and the output inductor value. During the on time of the low-side FET switch, this current decreases linearly. The average value of the switch current is the load current I_{OUT} . The device constantly monitors the low-side FET switch voltage, which is proportional to the switch current, during the low-side on-time. If the measured voltage is above the voltage proportional to the current limit, the converter maintains the low-side switch on until the measured voltage is below the voltage corresponding to the current limit at which time the switching cycle is terminated and a new switching cycle begins. In subsequent switching cycles, the on-time is set to a fixed value and the current is monitored in the same manner. If the overcurrent condition exists for 7 consecutive switching cycles, the internal OCL threshold is set to a lower level, reducing the available output current. When a switching cycle occurs where the switch current is not above the lower OCL threshold, the counter is reset and the OCL limit is returned to the higher value.

There are some important considerations for valley overcurrent protection. The average load current is half the peak-to-peak inductor current plus the valley overcurrent threshold during current limit. The output voltage falls as the demanded load current exceeds the current limit. When the FB voltage becomes lower than 65% of the target voltage, the UVP comparator detects it and the Hiccup sequence is initiated. After 10 μ s detecting the UVP voltage, device shuts down and re-starts after the hiccup time.

When the over current condition is removed, the output voltage returns to the regulated value.

8.3.5 UVLO Protection

Undervoltage lock out protection (UVLO) monitors the voltage of the VIN terminal. When the VIN voltage is lower than UVLO threshold voltage, the device is shut off. This protection is non-latching.

8.3.6 Thermal Shutdown

TPS566250 monitors the temperature of itself. If the temperature exceeds the threshold value (typically 165°C), the device is shut off. This is non-latch protection.

8.4 Device Functional Modes

8.4.1 Auto-Skip Eco-mode™ Control

The TPS566250 is designed with Advanced Eco-mode™ to increase light load efficiency. As the output current decreases from heavy load condition, the inductor current is also reduced and eventually comes to the where its ripple valley touches the zero level, which is the boundary between continuous conduction and discontinuous conduction modes. The rectifying MOSFET is turned off when its zero inductor current is detected. As the load current further decreases the converter run into discontinuous conduction mode. The on-time is lowered to reduce the output voltage ripple. The transition point to the light load operation $I_{O(LL)}$ current can be estimated with Equation 1 with 650 kHz used as f_{SW} .

$$I_{O(LL)} = \frac{1}{2 \times L_O \times f_{SW}} \times \frac{(V_{IN} - V_O) \times V_O}{V_{IN}} + 0.5 \text{ A} \quad (1)$$

8.5 Programming

8.5.1 I²C Interface

The TPS566250 implements a subset of the Phillips I²C specification Ver. 1.1. The TPS566250 is a Slave-Only (it never becomes a Master, and so never pulls down the **SCL** pin on the I²C bus). An I²C transaction consists of either writing a data byte to one of the device internal registers which requires a 3-byte transaction or reading back one byte from a register which requires a 4-byte transaction. The protocols follow the System Management Bus (SMBUS) Specification Ver. 2.0 *Write Byte and Read Byte* protocols. This spec is available on the Internet for further reading, but the subset implemented in TPS566250 is described as:

- Long-form address modes, multi-byte data transfers and Packet Error Code (PEC) protocols are not supported in this implementation, though a unique to the TPS566250.
- The I²C interface pins are composed of the **SDA** (Data) and **SCL** (Clock) pins. **SDA** and **SCL** are designed to be used with pullup resistors to 3.3 V.

8.5.2 I²C Protocol

8.5.2.1 Input Voltage

Logic levels for I²C **SDA** and **SCL** pins are not fixed. For the TPS566250, a logic “0” (LOW) should be 0 V and a logic “1” (HIGH) can be any voltage between 2.5 V and 3.3 V. Logic HIGH is generated by external pullup resistors (see [Output Voltage](#)).

8.5.2.2 Output Voltage

the I²C bus has external pullup resistors, one for SCL and one for SDA. These pull up to a voltage called V_{DD} which must lie between 2.5 V and 3.3 V. The outputs are pulled down to their logic LOW levels by open-drain outputs and pulled up to their logic HIGH levels by these external pullups. The pullups must be selected so that the current into any chip when pulled LOW by that chip’s open drain output ($=V_{DD}/R_{PULLUP}$) is less than 3 mA.

8.5.2.3 Data Format

One clock pulse on the **SCL** clock line is generated for each bit of data to be transferred. The data on the **SDA** line must be stable during the HIGH period of the **SCL** clock line. The HIGH or LOW state of the data line can only change when the clock signal on the **SCL** line is LOW.

8.5.2.4 START and STOP Conditions

A HIGH to LOW transition on the **SDA** line while the **SCL** line is HIGH defines a START condition. A LOW to HIGH transition on the **SDA** line while the **SCL** line is HIGH defines a STOP condition. START and STOP conditions are always generated by the Master. The bus is considered to be BUSY after the condition. It is considered to be free again after a minimum of 4.7 μ S after the STOP condition.

The bus stays busy if a repeated START (Sr) is generated instead of a STOP condition. START and repeated START are functionally identical.

Programming (continued)

Every byte of data out on the **SDA** line is 8 bits long. 9 clocks occur for each byte (the additional clock being for an ACK signal put onto the bus by the device pulling down on the bus to acknowledge receipt of the data). In the [Figure 13](#) and [Figure 14](#), shaded blocks indicate **SDA** data generated by the device being sent to the Master I²C controller, while white blocks indicate **SDA** data generated by the Master being received by the device. The Master always generates the **SCL** signal.

Sending data to the TPS566250 is accomplished using the following 3-byte sequence, referred to as a *Write Byte* transaction:

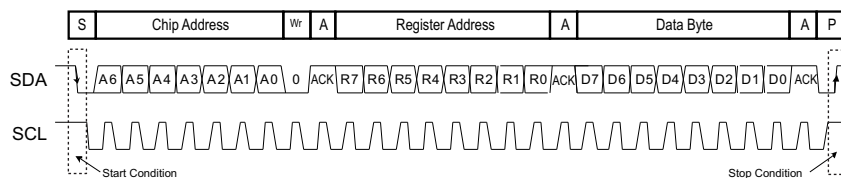

Figure 13. A Complete Write Byte Transfer, Adapted From SMBUS Spec

Reading back data from the TPS566250 is accomplished using the following 4-byte sequence, referred to as a *Read Byte* transaction:

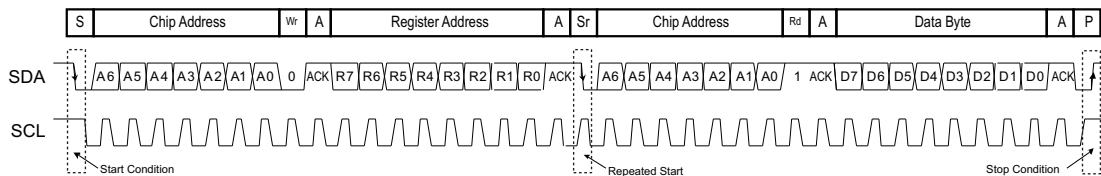

Figure 14. A Complete Read Byte Transfer, Adapted From SMBUS Spec

On the TPS566250, the I²C bus is inactive until:

1. Both SDA and SCL have been at a logic high simultaneously to prevent power sequencing issues.
2. VOUT is in regulation.

Control registers can be written after soft start is complete (1.7 times soft start time).

Until a VOUT command has been accepted, the device output voltage is determined by the external resistor divider feedback to the **FB** pin, the initial FB voltage (typically 0.6 V), and the condition of the **EN** pin.

When the device receives a Chip Address code it recognizes to be its own, it responds by sending an ACK (pulling down on the **SDA** bus during the next clock on the **SCL** bus). If the address is not recognized, the device assumes that the I²C message is intended for another chip on the bus, and it takes no action. It disregards data sent thereafter until the next START is begun.

If, after recognizing its Chip Address, the TPS566250 receives a valid Register Address, it sends an ACK and prepare to receive a Data Byte to be sent to that Register.

If a valid Data Byte is then received, it sends an ACK and sets the output voltage to the desired value. It is recommended to readback to verify the output voltage code. When sending data to the Output Voltage register, the output voltage only changes upon receipt of a valid data byte.

8.5.3 I²C Chip Address Byte

The 7-bit address of the TPS566250 is set at **31h** in hex notation (**0110001** in binary notation) internally. When the Master is sending the address as an 8-bit value, the 7-bit address should be sent followed by a trailing 0 to indicate this is a WRITE operation.

8.6 Register Maps

8.6.1 I²C Register Address Byte

The TPS566250 contains 2 customer-accessible registers. Register 0d (0h) is the output voltage register. Register 24d (18h) is the power good register

8.6.1.1 Output Voltage Register (offset = 00000000) [reset = 0h]

Register 0d (0h) is the Output Voltage register.

Figure 15. Output Voltage Register

7	6	5	4	3	2	1	0
Odd Parity		VOUT					
R/W				R/W			

LEGEND: R/W = Read/Write; R = Read only; -n = value after reset

Table 1. Output Voltage Register

Bit	Field	Type	Reset	Description
7	Odd Parity	R/W	0h	See Checksum Bit
6:0	VOUT	R/W	0h	See Table 3

8.6.1.2 Power Good State Register (offset = 00011000) [reset = 18h]

Register 24d (18h) provides the power good state

Figure 16. Power Good State Register

7	6	5	4	3	2	1	0
TI only						PGOOD	
R						R	

LEGEND: R/W = Read/Write; R = Read only; -n = value after reset

Table 2. Power Good Register

Bit	Field	Type	Reset	Description
7:1	TI only	R	0h	TI only
0	PGOOD	R	18h	1 = FB voltage within PGOOD threshold limits 0 = FB Voltage outside PGOOD threshold limits

8.6.2 CheckSum Bit

The CheckSum bit should be set by the Master controller to be the exclusive-OR of the D[6:0] bits (odd parity). This is used by the TPS566250 to check that a valid data byte was received. If CheckSum is not equal to the exclusive-OR of these bits, the TPS566250 assumes that an error occurred during the data transmission, nor does not reset the V_{OUT} to the received code (or, if the Control register does not reset the register contents as requested). The Master should try again to send the data.

8.6.3 Output Voltage Registers

The lower 7 bits of the Output Voltage Register controls the V_{OUT} of the device. These bits are the 7-bit selector for one of the output voltages. The default output voltage is 1.1 V, that is 50d (32h)

When the IC powers up, the startup and output voltage regulation conditions are set by the external resistor divider feedback to the **FB** pin, the initial FB voltage and the condition of the **EN** pin. Bringing the **EN** pin high begins a soft-start ramp on the regulator.

After applying V_{IN} , V_{OUT} comes into regulation and the I²C interface activates.

By default, the device regulates V_{OUT} using the external feedback resistors connected to the **FB** pin and the initial FB voltage. The user can then program V_{OUT} by writing any V_{OUT} code.

Table 3. Ideal V_{OUT} vs VOUT [6:0] Code
(Upper/lower Feedback Resistors: 1.37 k Ω / 1.65 k Ω) ^{(1) (2)}

Code	Binary	V_{OUT}	Code	Binary	VOUT	Code	Binary	VOUT	Code	Binary	VOUT
0	0000000	0.60	32	0100000	0.92	64	1000000	1.24	96	1100000	1.56
1	0000001	0.61	33	0100001	0.93	65	1000001	1.25	97	1100001	1.57
2	0000010	0.62	34	0100010	0.94	66	1000010	1.26	98	1100010	1.58
3	0000011	0.63	35	0100011	0.95	67	1000011	1.27	99	1100011	1.59
4	0000100	0.64	36	0100100	0.96	68	1000100	1.28	100	1100100	1.60
5	0000101	0.65	37	0100101	0.97	69	1000101	1.29	101	1100101	1.61
6	0000110	0.66	38	0100110	0.98	70	1000110	1.30	102	1100110	1.62
7	0000111	0.67	39	0100111	0.99	71	1000111	1.31	103	1100111	1.63
8	0001000	0.68	40	0101000	1.00	72	1001000	1.32	104	1101000	1.64
9	0001001	0.69	41	0101001	1.01	73	1001001	1.33	105	1101001	1.65
10	0001010	0.70	42	0101010	1.02	74	1001010	1.34	106	1101010	1.66
11	0001011	0.71	43	0101011	1.03	75	1001011	1.35	107	1101011	1.67
12	0001100	0.72	44	0101100	1.04	76	1001100	1.36	108	1101100	1.68
13	0001101	0.73	45	0101101	1.05	77	1001101	1.37	109	1101101	1.69
14	0001110	0.74	46	0101110	1.06	78	1001110	1.38	110	1101110	1.70
15	0001111	0.75	47	0101111	1.07	79	1001111	1.39	111	1101111	1.71
16	0010000	0.76	48	0110000	1.08	80	1010000	1.40	112	1110000	1.72
17	0010001	0.77	49	0110001	1.09	81	1010001	1.41	113	1110001	1.73
18	0010010	0.78	50	0110010	1.10	82	1010010	1.42	114	1110010	1.74
19	0010011	0.79	51	0110011	1.11	83	1010011	1.43	115	1110011	1.75
20	0010100	0.80	52	0110100	1.12	84	1010100	1.44	116	1110100	1.76
21	0010101	0.81	53	0110101	1.13	85	1010101	1.45	117	1110101	1.77
22	0010110	0.82	54	0110110	1.14	86	1010110	1.46	118	1110110	1.78
23	0010111	0.83	55	0110111	1.15	87	1010111	1.47	119	1110111	1.79
24	0011000	0.84	56	0111000	1.16	88	1011000	1.48	120	1111000	1.80
25	0011001	0.85	57	0111001	1.17	89	1011001	1.49	121	1111001	1.81
26	0011010	0.86	58	0111010	1.18	90	1011010	1.50	122	1111010	1.82
27	0011011	0.87	59	0111011	1.19	91	1011011	1.51	123	1111011	1.83
28	0011100	0.88	60	0111100	1.20	92	1011100	1.52	124	1111100	1.84
29	0011101	0.89	61	0111101	1.21	93	1011101	1.53	125	1111101	1.85
30	0011110	0.90	62	0111110	1.22	94	1011110	1.54	126	1111110	1.86
31	0011111	0.91	63	0111111	1.23	95	1011111	1.55	127	1111111	1.87

(1) 10-mV output voltage steps can be applied to 1.1-V output voltage setting only.

(2) For other default voltage setting, the output voltage step are shown in [Equation 2](#).

$$\text{Output Voltage Step} = 10 \times \text{Target Output Voltage} / 1.1 \text{ mV}$$

(2)

8.6.4 Summary of Default Control Bits

8.6.4.1 DAC Settle

When a new V_{OUT} voltage is selected, this happens by setting an internal DAC to a new internal V_{REF} voltage. If this happens instantly, the regulator loop is thrown out of regulation and the DCAP2 loop must respond to bring the V_{OUT} back into regulation at its new chosen value. To reduce V_{OUT} overshoots (or undershoots) or high transient input currents due to the internal V_{REF} change, There is an analog filter on the DAC output. The filter is set at 20 μ s constant.

8.6.4.2 Operation During V_{ID} Transition

The device temporarily goes into forced CCM mode during V_{ID} transitions for approximately 100 μ s. This helps discharge V_{OUT} during a step down when there is a light load present. The Power Good is masked for approximately 100 μ s to prevent a power good flag during the transition.

CONTROL BIT(S)	DEFAULT	FUNCTION
VOUT[7:0]	0110010 (32h)	V_{OUT} code, 7 bits VOUT[6:0] + odd parity checksum bit at VOUT[7]. Writing a valid code to this register also sets VID Mode. Sending an invalid code (checksum incorrect) to this register does not change register contents or set Internal/Enable bits.

9 Applications and Implementation

NOTE

Information in the following applications sections is not part of the TI component specification, and TI does not warrant its accuracy or completeness. TI's customers are responsible for determining suitability of components for their purposes. Customers should validate and test their design implementation to confirm system functionality.

9.1 Application Information

The devices are synchronous step down DC-DC converters rated at different output currents whose output voltage can be dynamically scaled by sending commands over an I²C interface. This section discusses the design of the external components to complete the power supply design by using a typical application as a reference.

9.2 Typical Application

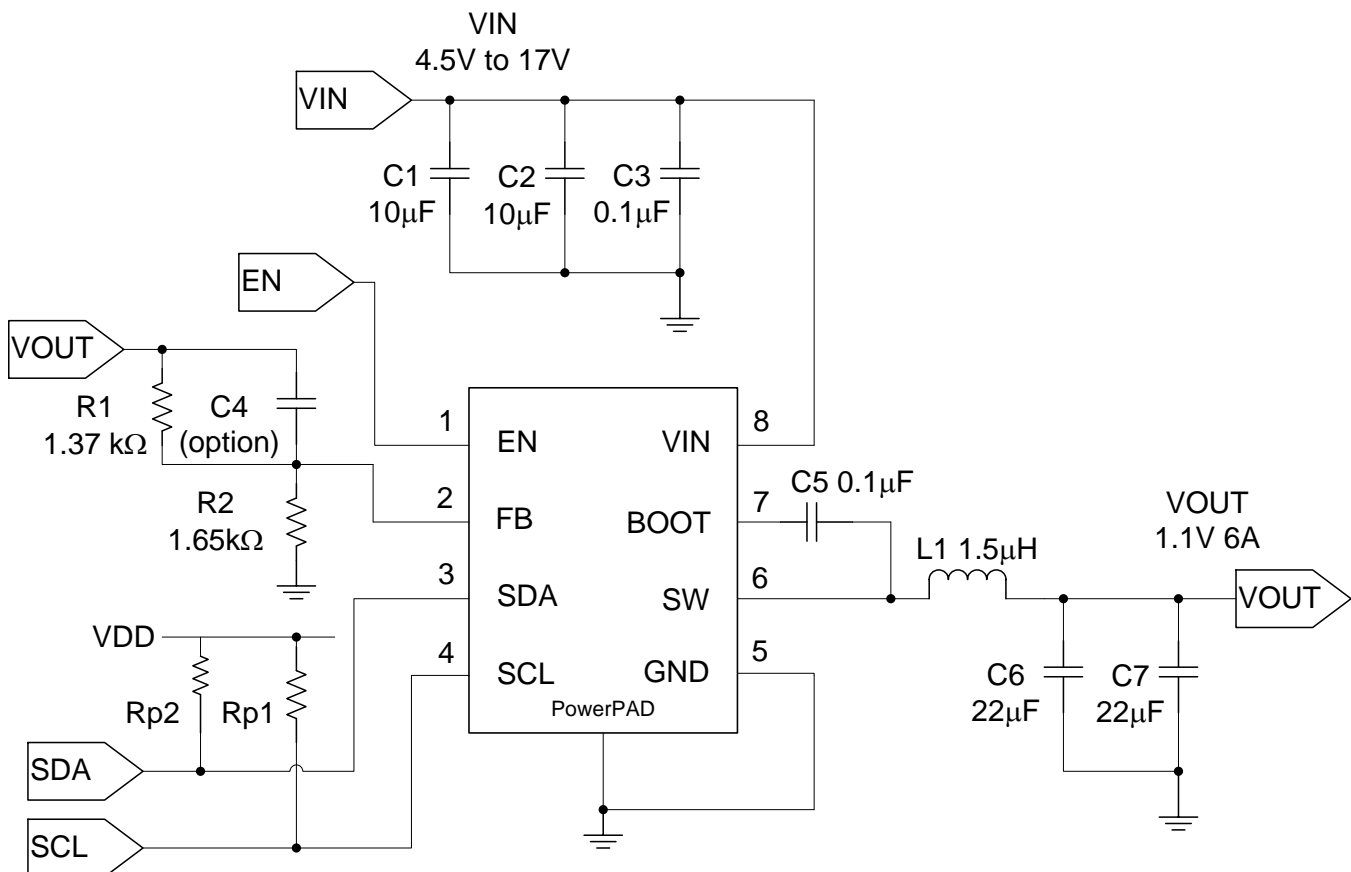

Figure 17. Typical Application Schematic

Typical Application (continued)

9.2.1 Design Requirements

For this design example, use the parameters shown in [Table 4](#).

Table 4. Design Example

DESIGN PARAMETER	EXAMPLE VALUE
Input voltage	12 V
Output voltage	1.1 V
Transient response, 0 A – 6 A load step	$\Delta V_{OUT} = \pm 5\%$
Output voltage ripple	25 mV
Input ripple voltage	400 mV
Output current rating	6 A
Operating Frequency	650 kHz

9.2.2 Detailed Design Procedure

9.2.2.1 Output Voltage Resistors Selection

The output voltage is set with a resistor divider from the output node to the FB pin. It is recommended to use 1% tolerance or better divider resistors. Use 1.37 k Ω for R1 and 1.65 k Ω for R2.

$$V_{(FB)} = V_O \times \frac{R2}{R1 + R2} \quad (3)$$

9.2.2.2 Output Filter Selection

The output filter used with the TPS566250 is an LC circuit. This LC filter has double pole at:

$$F_P = \frac{1}{2\pi \sqrt{L_O \times C_O}} \quad (4)$$

At low frequencies, the overall loop gain is set by the output set-point resistor divider network and the internal gain of the device. The low frequency phase is 180 degrees. At the output filter pole frequency, the gain rolls off at a –40 dB per decade rate and the phase drops rapidly. D-CAP2™ introduces a high frequency zero that reduces the gain roll off to –20 dB per decade and increases the phase to 90 degrees one decade above the zero frequency. The inductor and capacitor selected for the output filter must be selected so that the double pole of [Equation 4](#) is located below the high frequency zero but close enough that the phase boost provided by the high frequency zero provides adequate phase margin for a stable circuit. To meet this requirement use the values recommended in [Table 5](#).

Table 5. Recommended Component Values

Output Voltage (V)	R1 (k Ω)	R2 (k Ω)	C4 (pF) ⁽¹⁾			L1 (μ H)			C67 (μ F)
			MIN	TYP	MAX	MIN	TYP	MAX	
1	1.37	1.65					1.5		22 - 68
1.1 (Default)	1.37	1.65					1.5		22 - 68
1.2	1.37	1.65					1.5		22 - 68
1.5	1.37	1.65					1.5		22 - 68
1.8	1.37	1.65					1.5		22 - 68

(1) Optional

The inductor peak-to-peak ripple current, peak current and RMS current are calculated using [Equation 5](#), [Equation 6](#) and [Equation 7](#). The inductor saturation current rating must be greater than the calculated peak current and the RMS or heating current rating must be greater than the calculated RMS current. For the calculations, use 500 kHz as the switching frequency, f_{SW} . Make sure the chosen inductor is rated for the peak current of [Equation 6](#) and the RMS current of [Equation 7](#).

$$\Delta I_{LO} = \frac{V_O}{V_{IN(MAX)}} \times \frac{V_{IN(MAX)} - V_O}{L_O \times f_{SW}} \quad (5)$$

$$I_{LPEAK} = I_O + \frac{\Delta I_L}{2} \quad (6)$$

$$I_{LO(RMS)} = \sqrt{I_O^2 + \frac{1}{12} \Delta I_L^2} \quad (7)$$

The capacitor value and ESR determines the amount of output voltage ripple. The TPS566250 is intended for use with ceramic or other low ESR capacitors. Recommended values range from 22 μF to 68 μF .

9.2.2.3 Input Capacitor Selection

The TPS566250 requires an input decoupling capacitor and a bulk capacitor depending on the application. A ceramic capacitor of 10 μF or above is recommended for the decoupling capacitor. Additionally, a 0.1- μF ceramic capacitor from V_{IN} to GND is also recommended to improve the stability and reduce the SW node overshoots. The capacitors voltage rating needs to be greater than the maximum input voltage.

9.2.2.4 Bootstrap Capacitor Selection

The 0.1- μF ceramic capacitors must be connected between the BOOT to SW pins for proper operation. It is recommended to use ceramic capacitors with a dielectric of X5R or better.

9.2.3 Application Performance Curves

$V_{IN} = 12\text{ V}$, $V_{OUT} = 1.1\text{ V}$, $T_A = 25^\circ\text{C}$, unless otherwise specified.

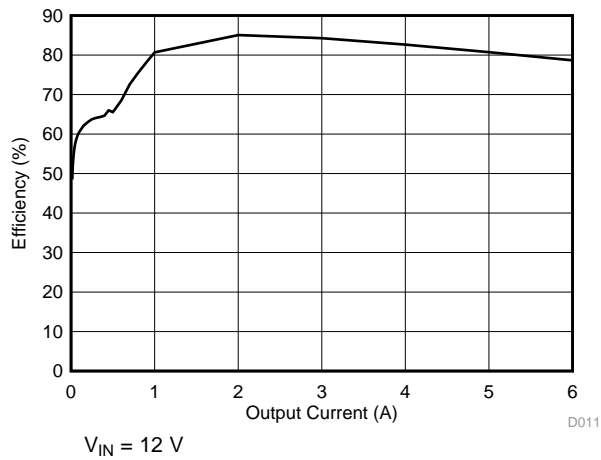

Figure 18. Efficiency vs Output Current

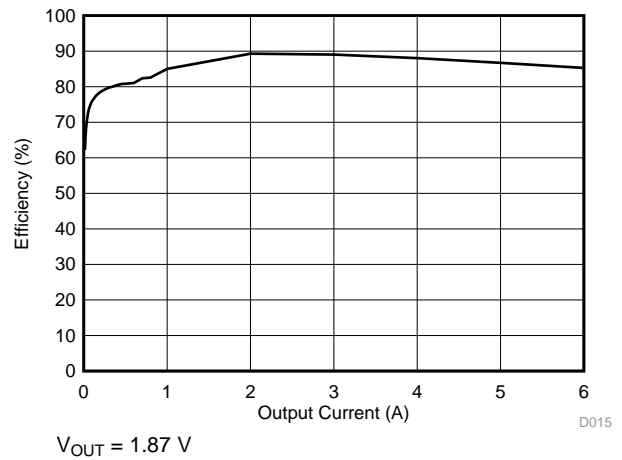

Figure 19. Efficiency vs Output Current

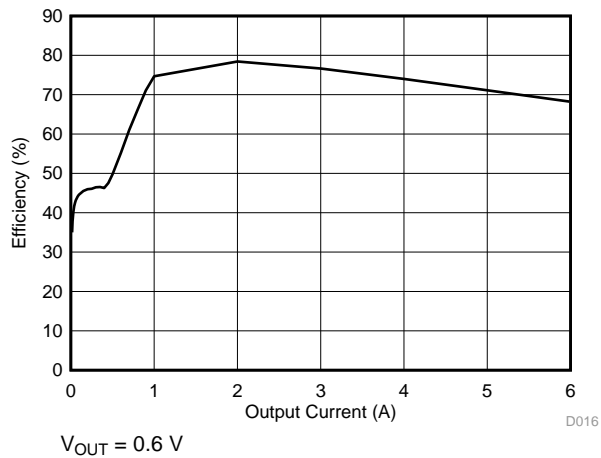

Figure 20. Efficiency vs Output Current

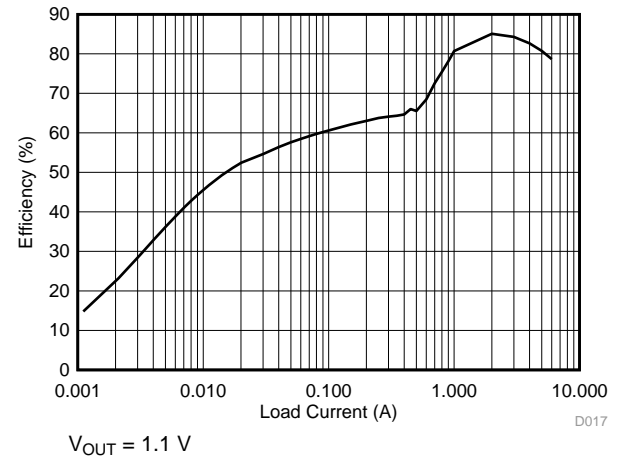

Figure 21. Efficiency vs Load Current

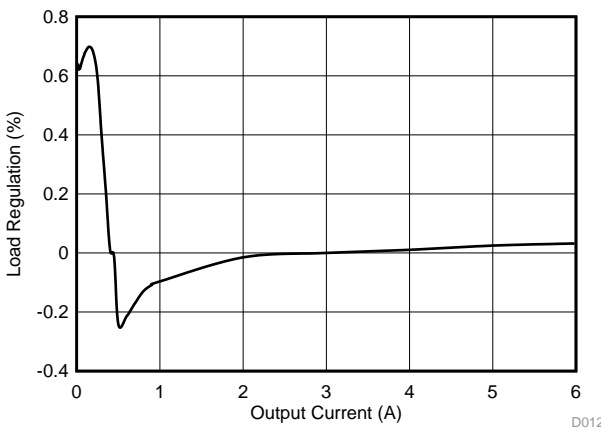

Figure 22. Load Regulation

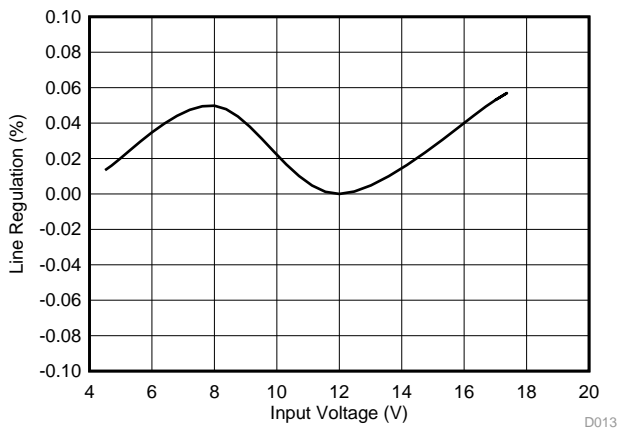

Figure 23. Line Regulation

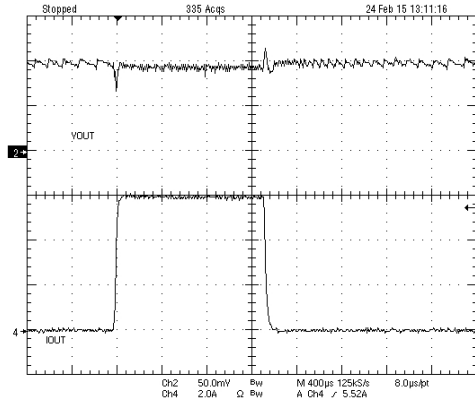

Figure 24. Load Transient

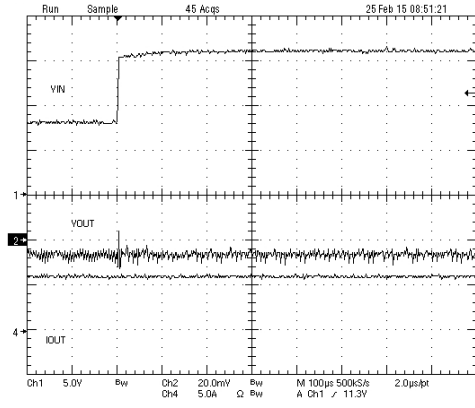

Figure 25. Line Transient

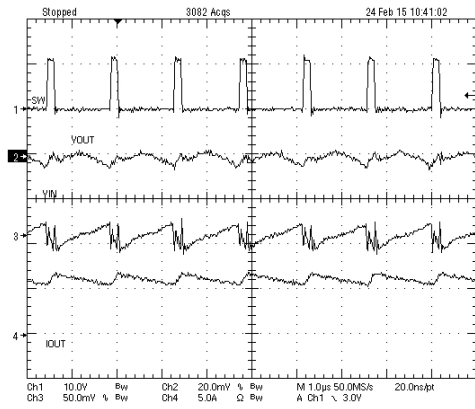

Figure 26. Continuous Conduction Mode (Inductor Current)

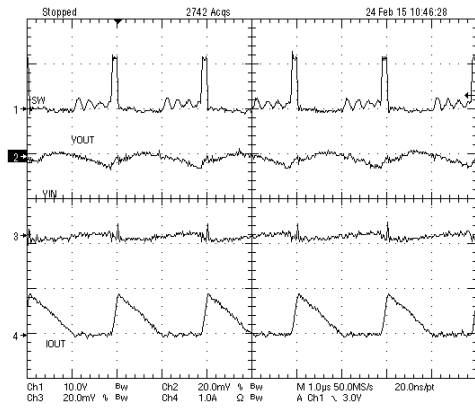

Figure 27. Discontinuous Conduction Mode (Inductor Current)

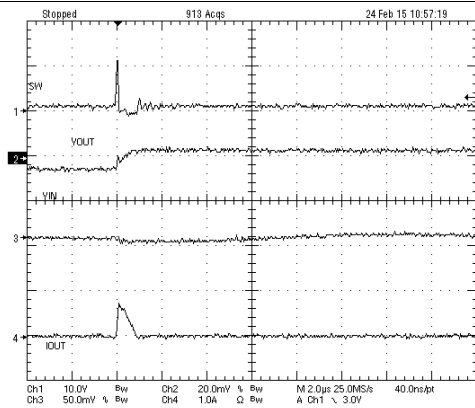

Figure 28. Skip Mode (Inductor Current)

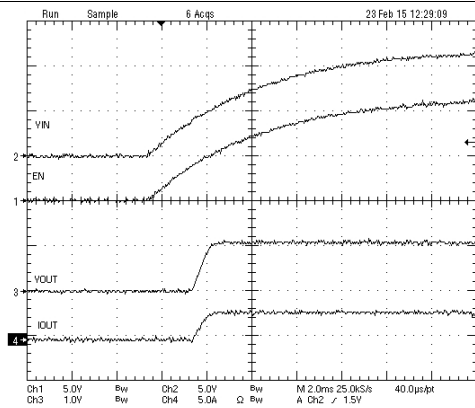

Figure 29. Start Up With VIN

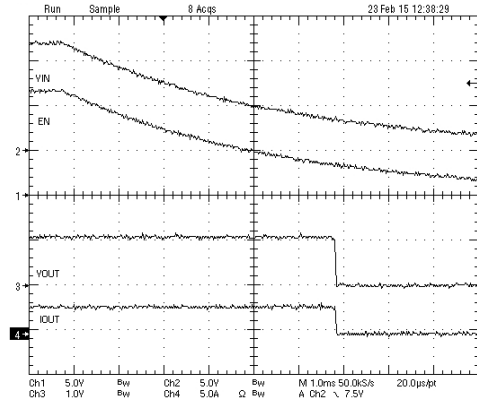

Figure 30. Power Down VIN

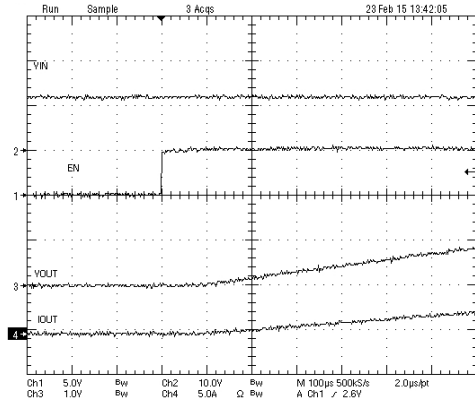

Figure 31. Start Up With EN

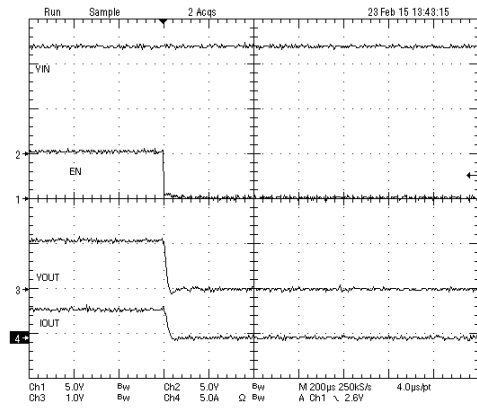

Figure 32. Power Down with EN

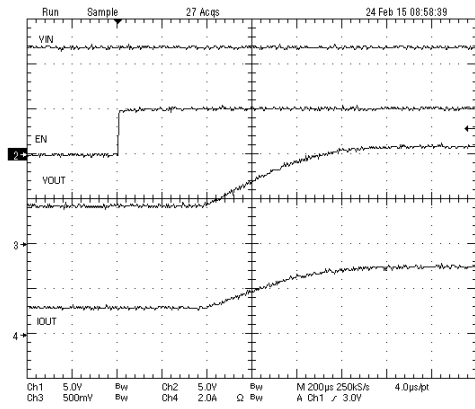

Figure 33. Start Up With EN and Prebias

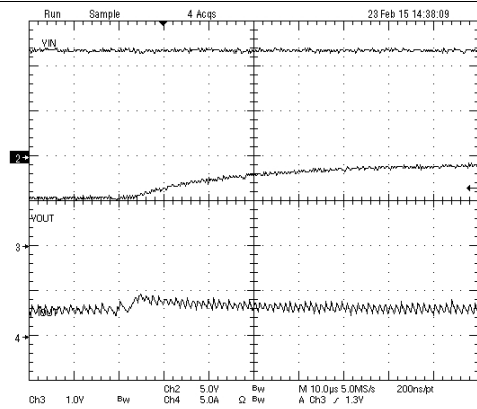

Figure 34. V_{OUT} Step Up With V_{ID}

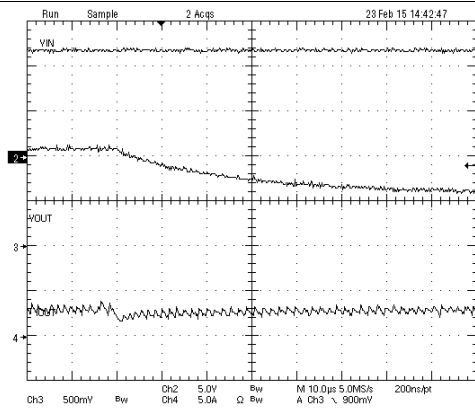

Figure 35. V_{OUT} Step Down With V_{ID}

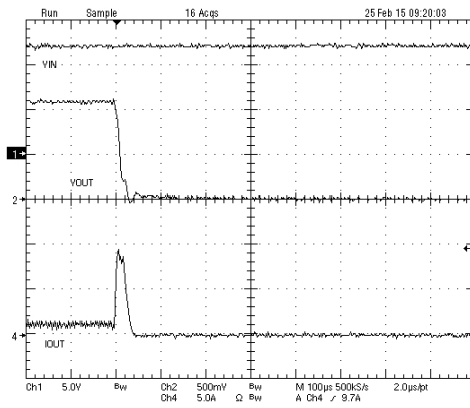

Figure 36. Hiccup Current Limit

10 Power Supply Recommendations

The devices are designed to operate from an input supply range between 4.5 V and 17 V. This input supply must be well regulated. If the input supply is located more than a few inches from the TPS566250 device, additional bulk capacitance may be required in addition to the ceramic bypass capacitors.

11 Layout

11.1 Layout Guidelines

- Keep the input switching current loop as small as possible.
- Keep the SW node as physically small and short as possible to minimize parasitic capacitance and inductance and to minimize radiated emissions. Kelvin connections should be brought from the output to the feedback terminal of the device.
- Keep analog and non-switching components away from switching components.
- Make a single point connection from the signal ground to power ground
- Keep the pattern lines for VIN and GND broad.
- Exposed pad of device must be connected to GND with solder.
- Output capacitor should be connected to a broad pattern of the GND.
- Voltage feedback loop should be as short as possible, and preferably with ground shield.
- Kelvin connections should be brought from the output to the feedback terminal of the device.
- Providing sufficient via is preferable for VIN, SW and GND connection.
- PCB pattern for VIN, SW, and GND should be as broad as possible.
- Input capacitors should be placed as near as possible to the device.
- If possible, it is preferred not to allow switching current to flow under the device

11.2 Layout Example

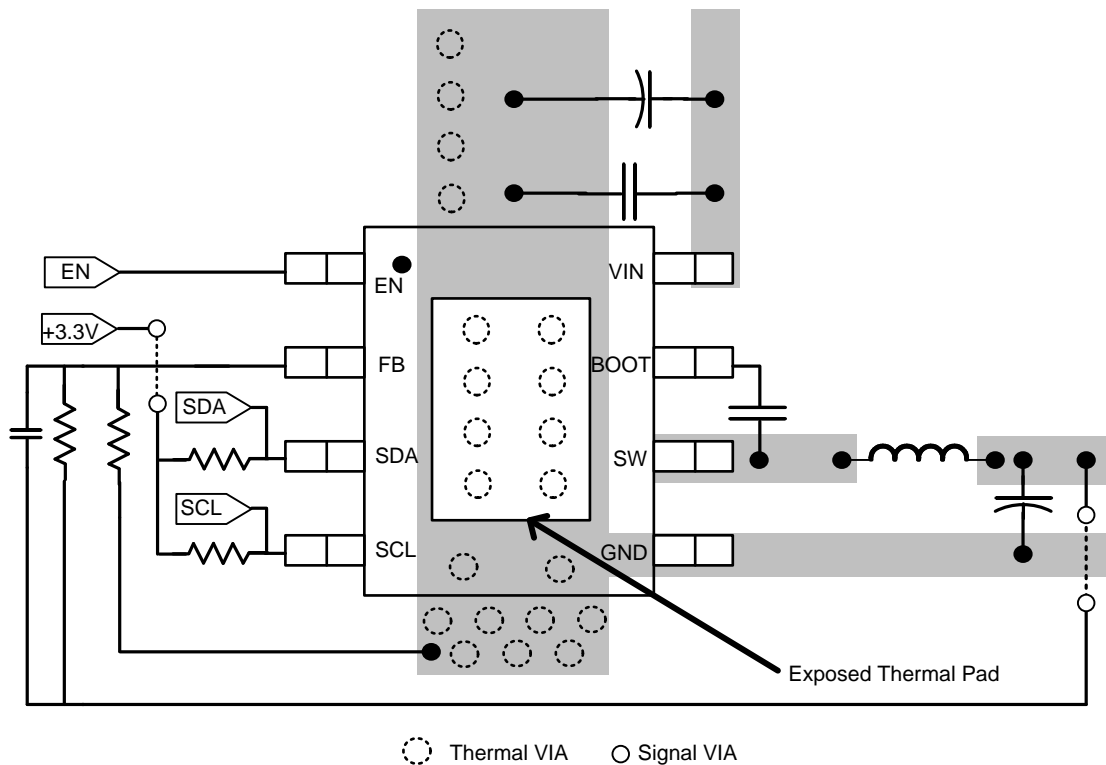

Figure 37. Layout

12 器件和文档支持

12.1 文档支持

12.2 商标

D-CAP2, Eco-mode, PowerPAD are trademarks of Texas Instruments.
All other trademarks are the property of their respective owners.

12.3 静电放电警告



这些装置包含有限的内置 ESD 保护。存储或装卸时，应将导线一起截短或将装置放置于导电泡棉中，以防止 MOS 门极遭受静电损伤。

12.4 术语表

[SLYZ022](#) — TI 术语表。

这份术语表列出并解释术语、首字母缩略词和定义。

13 机械封装和可订购信息

以下页中包括机械封装和可订购信息。 这些信息是针对指定器件可提供的最新数据。 这些数据会在无通知且不对本文档进行修订的情况下发生改变。 欲获得该数据表的浏览器版本，请查阅左侧的导航栏。

13.1 热性能信息

这种 8 引脚 DDA 封装包含一个外露散热焊盘，专用于直接连接外部散热器。 该散热焊盘必须直接焊接到印刷电路板 (PCB) 上。 完成焊接后，可将 PCB 用作散热器。 此外，还可以通过散热过孔将散热焊盘直接与器件电气原理图中所示的敷铜层相连，或者与在 PCB 中设计的特殊散热结构相连。 这种设计可以优化集成电路 (IC) 的热传递。

如需了解有关外露散热焊盘的更多信息以及如何善用其散热能力的优势，请参见《PowerPAD™ 耐热增强型封装》技术简介（德州仪器 (TI) 文献编号 [SLMA002](#)）以及《PowerPAD™ 速成》应用简介（德州仪器 (TI) 文献编号 [SLMA004](#)）。 此类封装的外露散热焊盘尺寸如下图所示。

PACKAGING INFORMATION

Orderable Device	Status (1)	Package Type	Package Drawing	Pins	Package Qty	Eco Plan (2)	Lead finish/ Ball material (6)	MSL Peak Temp (3)	Op Temp (°C)	Device Marking (4/5)	Samples
TPS566250DDA	ACTIVE	SO PowerPAD	DDA	8	75	RoHS & Green	SN	Level-2-260C-1 YEAR	-40 to 85	566250	Samples
TPS566250DDAR	ACTIVE	SO PowerPAD	DDA	8	2500	RoHS & Green	SN	Level-2-260C-1 YEAR	-40 to 85	566250	Samples

(1) The marketing status values are defined as follows:

ACTIVE: Product device recommended for new designs.

LIFEBUY: TI has announced that the device will be discontinued, and a lifetime-buy period is in effect.

NRND: Not recommended for new designs. Device is in production to support existing customers, but TI does not recommend using this part in a new design.

PREVIEW: Device has been announced but is not in production. Samples may or may not be available.

OBSOLETE: TI has discontinued the production of the device.

(2) **RoHS:** TI defines "RoHS" to mean semiconductor products that are compliant with the current EU RoHS requirements for all 10 RoHS substances, including the requirement that RoHS substance do not exceed 0.1% by weight in homogeneous materials. Where designed to be soldered at high temperatures, "RoHS" products are suitable for use in specified lead-free processes. TI may reference these types of products as "Pb-Free".

RoHS Exempt: TI defines "RoHS Exempt" to mean products that contain lead but are compliant with EU RoHS pursuant to a specific EU RoHS exemption.

Green: TI defines "Green" to mean the content of Chlorine (Cl) and Bromine (Br) based flame retardants meet JS709B low halogen requirements of <=1000ppm threshold. Antimony trioxide based flame retardants must also meet the <=1000ppm threshold requirement.

(3) MSL, Peak Temp. - The Moisture Sensitivity Level rating according to the JEDEC industry standard classifications, and peak solder temperature.

(4) There may be additional marking, which relates to the logo, the lot trace code information, or the environmental category on the device.

(5) Multiple Device Markings will be inside parentheses. Only one Device Marking contained in parentheses and separated by a "~" will appear on a device. If a line is indented then it is a continuation of the previous line and the two combined represent the entire Device Marking for that device.

(6) Lead finish/Ball material - Orderable Devices may have multiple material finish options. Finish options are separated by a vertical ruled line. Lead finish/Ball material values may wrap to two lines if the finish value exceeds the maximum column width.

Important Information and Disclaimer:The information provided on this page represents TI's knowledge and belief as of the date that it is provided. TI bases its knowledge and belief on information provided by third parties, and makes no representation or warranty as to the accuracy of such information. Efforts are underway to better integrate information from third parties. TI has taken and continues to take reasonable steps to provide representative and accurate information but may not have conducted destructive testing or chemical analysis on incoming materials and chemicals. TI and TI suppliers consider certain information to be proprietary, and thus CAS numbers and other limited information may not be available for release.

In no event shall TI's liability arising out of such information exceed the total purchase price of the TI part(s) at issue in this document sold by TI to Customer on an annual basis.

TAPE AND REEL INFORMATION

QUADRANT ASSIGNMENTS FOR PIN 1 ORIENTATION IN TAPE

*All dimensions are nominal

Device	Package Type	Package Drawing	Pins	SPQ	Reel Diameter (mm)	Reel Width W1 (mm)	A0 (mm)	B0 (mm)	K0 (mm)	P1 (mm)	W (mm)	Pin1 Quadrant
TPS566250DDAR	SO Power PAD	DDA	8	2500	330.0	12.8	6.4	5.2	2.1	8.0	12.0	Q1

TAPE AND REEL BOX DIMENSIONS

*All dimensions are nominal

Device	Package Type	Package Drawing	Pins	SPQ	Length (mm)	Width (mm)	Height (mm)
TPS566250DDAR	SO PowerPAD	DDA	8	2500	366.0	364.0	50.0

TUBE



*All dimensions are nominal

Device	Package Name	Package Type	Pins	SPQ	L (mm)	W (mm)	T (μm)	B (mm)
TPS566250DDA	DDA	HSOIC	8	75	517	7.87	635	4.25

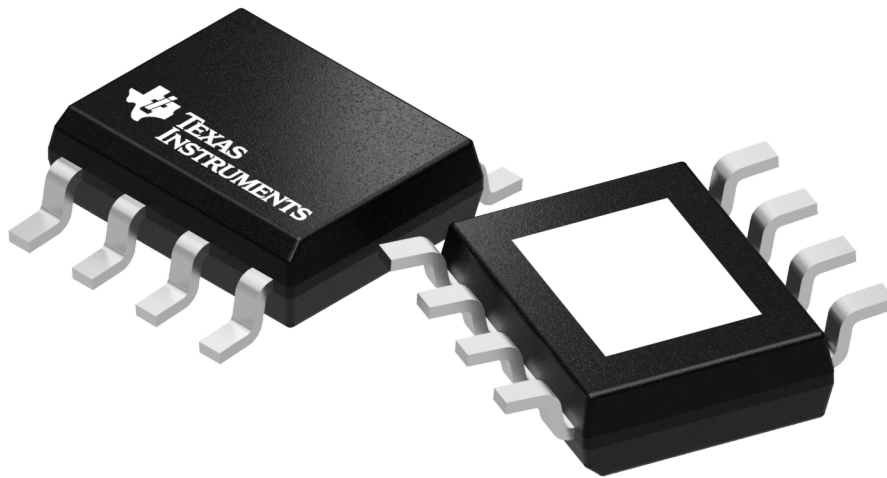

Images above are just a representation of the package family, actual package may vary.
Refer to the product data sheet for package details.

DDA (R-PDSO-G8)

PowerPAD™ PLASTIC SMALL-OUTLINE

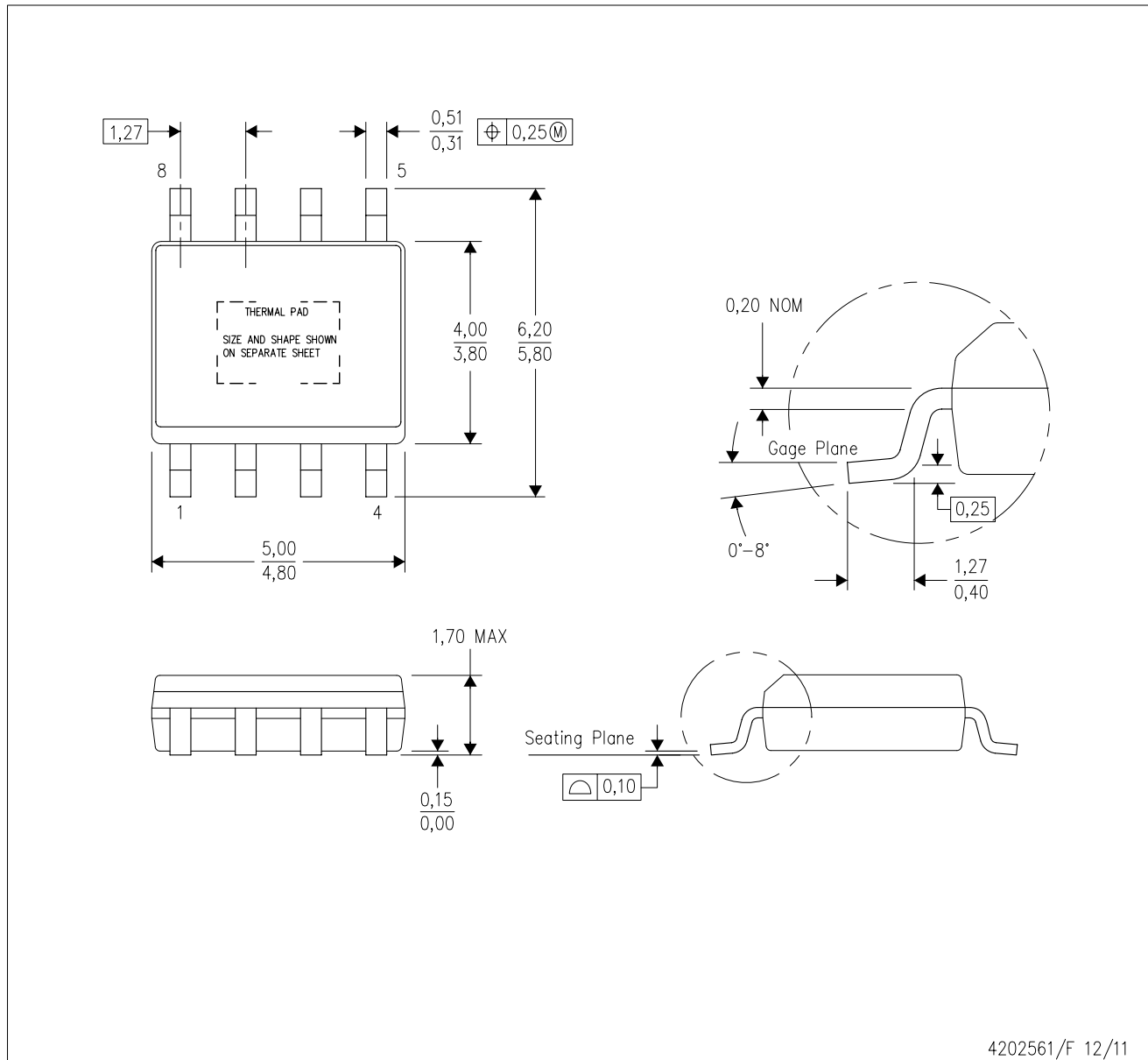

- NOTES:
- A. All linear dimensions are in millimeters. Dimensioning and tolerancing per ASME Y14.5-1994.
 - B. This drawing is subject to change without notice.
 - C. Body dimensions do not include mold flash or protrusion not to exceed 0,15.
 - D. This package is designed to be soldered to a thermal pad on the board. Refer to Technical Brief, PowerPad Thermally Enhanced Package, Texas Instruments Literature No. SLMA002 for information regarding recommended board layout. This document is available at www.ti.com <<http://www.ti.com>>.
 - E. See the additional figure in the Product Data Sheet for details regarding the exposed thermal pad features and dimensions.
 - F. This package complies to JEDEC MS-012 variation BA

PowerPAD is a trademark of Texas Instruments.

DDA (R-PDSO-G8)

PowerPAD™ PLASTIC SMALL OUTLINE

THERMAL INFORMATION

This PowerPAD™ package incorporates an exposed thermal pad that is designed to be attached to a printed circuit board (PCB). The thermal pad must be soldered directly to the PCB. After soldering, the PCB can be used as a heatsink. In addition, through the use of thermal vias, the thermal pad can be attached directly to the appropriate copper plane shown in the electrical schematic for the device, or alternatively, can be attached to a special heatsink structure designed into the PCB. This design optimizes the heat transfer from the integrated circuit (IC).

For additional information on the PowerPAD package and how to take advantage of its heat dissipating abilities, refer to Technical Brief, PowerPAD Thermally Enhanced Package, Texas Instruments Literature No. SLMA002 and Application Brief, PowerPAD Made Easy, Texas Instruments Literature No. SLMA004. Both documents are available at www.ti.com.

The exposed thermal pad dimensions for this package are shown in the following illustration.

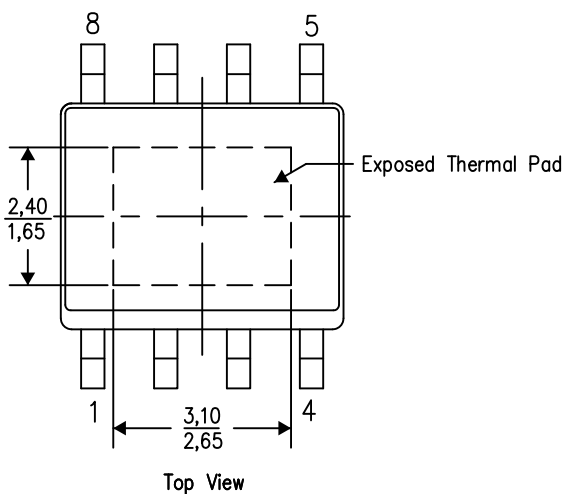

Exposed Thermal Pad Dimensions

4206322-6/L 05/12

NOTE: A. All linear dimensions are in millimeters

PowerPAD is a trademark of Texas Instruments

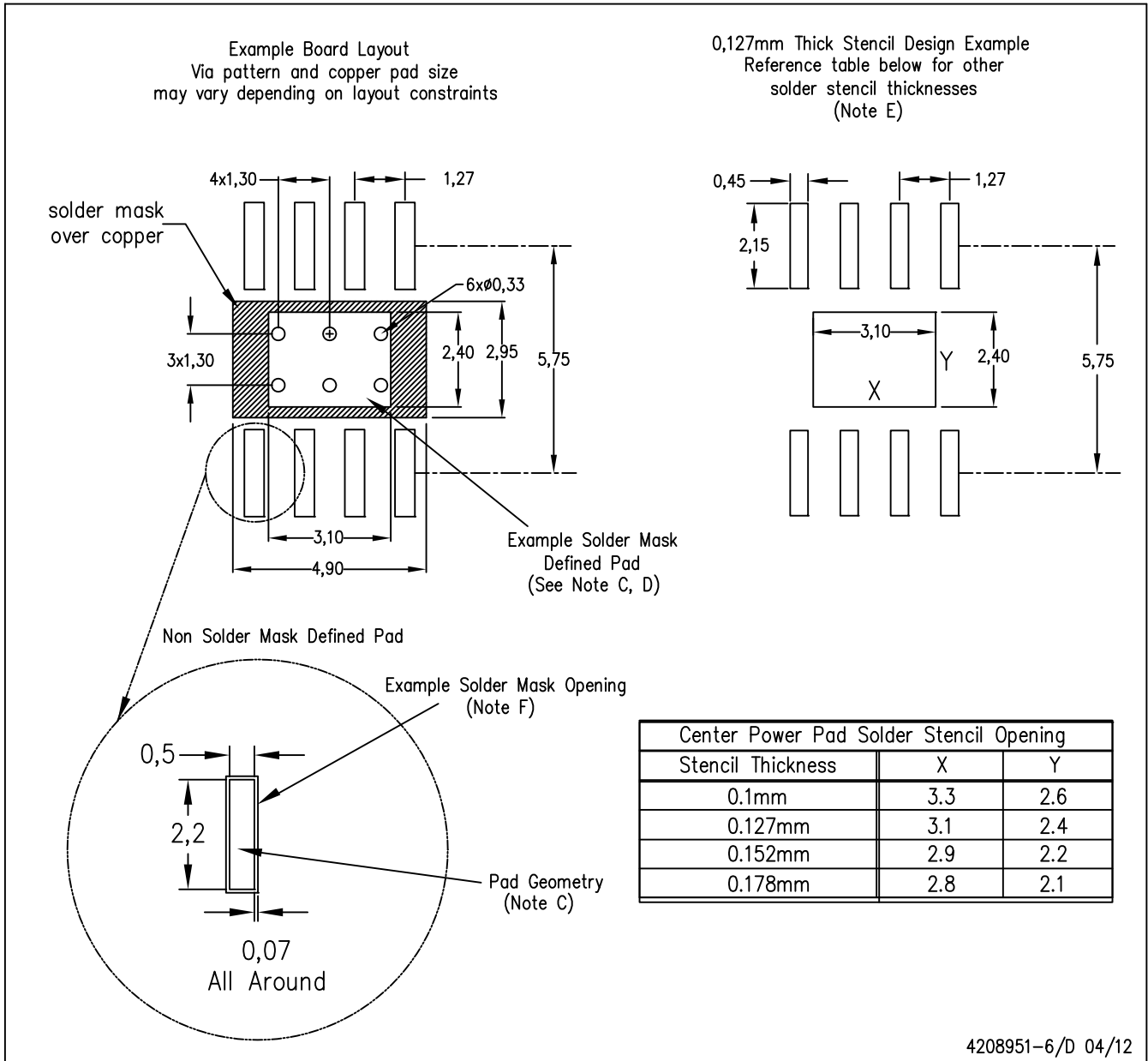

- NOTES:
- A. All linear dimensions are in millimeters.
 - B. This drawing is subject to change without notice.
 - C. Publication IPC-7351 is recommended for alternate designs.
 - D. This package is designed to be soldered to a thermal pad on the board. Refer to Technical Brief, PowerPad Thermally Enhanced Package, Texas Instruments Literature No. SLMA002, SLMA004, and also the Product Data Sheets for specific thermal information, via requirements, and recommended board layout. These documents are available at www.ti.com <<http://www.ti.com>>. Publication IPC-7351 is recommended for alternate designs.
 - E. Laser cutting apertures with trapezoidal walls and also rounding corners will offer better paste release. Customers should contact their board assembly site for stencil design recommendations. Example stencil design based on a 50% volumetric metal load solder paste. Refer to IPC-7525 for other stencil recommendations.
 - F. Customers should contact their board fabrication site for solder mask tolerances between and around signal pads.

PowerPAD is a trademark of Texas Instruments.

重要声明和免责声明

TI“按原样”提供技术和可靠性数据（包括数据表）、设计资源（包括参考设计）、应用或其他设计建议、网络工具、安全信息和其他资源，不保证没有瑕疵且不做任何明示或暗示的担保，包括但不限于对适销性、某特定用途方面的适用性或不侵犯任何第三方知识产权的暗示担保。

这些资源可供使用 TI 产品进行设计的熟练开发人员使用。您将自行承担以下全部责任：(1) 针对您的应用选择合适的 TI 产品，(2) 设计、验证并测试您的应用，(3) 确保您的应用满足相应标准以及任何其他功能安全、信息安全、监管或其他要求。

这些资源如有变更，恕不另行通知。TI 授权您仅可将这些资源用于研发本资源所述的 TI 产品的应用。严禁对这些资源进行其他复制或展示。您无权使用任何其他 TI 知识产权或任何第三方知识产权。您应全额赔偿因在这些资源的使用中对 TI 及其代表造成的任何索赔、损害、成本、损失和债务，TI 对此概不负责。

TI 提供的产品受 [TI 的销售条款](#) 或 [ti.com](#) 上其他适用条款/TI 产品随附的其他适用条款的约束。TI 提供这些资源并不会扩展或以其他方式更改 TI 针对 TI 产品发布的适用的担保或担保免责声明。

TI 反对并拒绝您可能提出的任何其他或不同的条款。

邮寄地址：Texas Instruments, Post Office Box 655303, Dallas, Texas 75265

Copyright © 2022，德州仪器 (TI) 公司