

MSP432E401Y SimpleLink™ 以太网微控制器

1 器件概述

1.1 特性

- 内核
 - 120MHz ARM® Cortex®- 具有浮点运算单元 (FPU) 的 M4F 处理器内核
- 连接
 - 以太网 MAC: 具有集成以太网 PHY 的 10/100 以太网 MAC
 - 以太网 PHY: 具有 IEEE 1588 PTP 硬件支持的 PHY
 - 通用串行总线 (USB): 具有 ULPI 接口选项和链路层电源管理 (LPM) 的 USB 2.0 OTG、主机或器件
 - 8 个通用异步接收器/发射器 (UART), 每个具有独立计时的发送器和接收器
 - 4 个四通道同步串行接口 (QSSI): 提供双通道、四通道和高级 SSI 支持
 - 提供高速模式支持的 10 个内部集成电路 (I²C) 模块
 - 2 个 CAN 2.0 A 和 B 控制器: 多播共享串行总线标准
- 存储器
 - 具有 4 个存储体的 1024KB 闪存存储器配置支持对每个存储体提供独立代码保护
 - 具有单周期访问的 256KB SRAM 以 120MHz 时钟频率提供近 2GB/s 的内存带宽
 - 6KB EEPROM: 每 2 个页块写入 500k、矫正、锁定保护
 - 内部 ROM: 搭载有 SimpleLink™ SDK 软件
 - 外设驱动程序库
 - 引导加载程序
 - 外部外设接口 (EPI): 8、16 或 32 位专用并行接口访问外部器件和存储器 (SDRAM、闪存或 SRAM)
- 安全性
 - 高级加密标准 (AES): 基于 128、192 和 256 位密钥的硬件加速数据加密和解密
 - 数据加密标准 (DES): 具有 168 位有效密钥长度并且支持块密码实施的硬件加速数据加密和解密
 - 安全哈希算法/消息摘要算法 (SHA/MD5): 支持 SHA-1、SHA-2 和 MD5 哈希计算的高级哈希引擎
 - 循环冗余校验 (CRC) 硬件
 - 篡改: 支持四个篡改输入和可配置篡改事件响应
- 模拟
 - 2 个基于 12 位 SAR 的 ADC 模块, 每个模块支持高达 200 万次/秒的采样率 (2Msps)
 - 3 个独立的模拟比较器控制器
 - 16 个数字比较器
- 系统管理
 - JTAG 和串行线调试 (SWD): 一个具有集成 ARM SWD 的 JTAG 模块提供访问和控制测试设计特性的途径, 如 I/O 引脚监督和控制、扫描测试和调试。
- 开发套件和软件 (请参阅 [工具和软件](#))
 - SimpleLink™ MSP-EXP432E401Y LaunchPad™ 开发套件
 - SimpleLink MSP432E4 软件开发套件 (SDK)
- 封装信息
 - 封装: 128 引脚 TQFP (PDT)
 - 扩展工作温度 (环境) 范围: -40°C 至 105°C

1.2 应用

- 工业以太网网关
- 工业智能网关
- 适用于楼宇自动化的区域控制器
- 工厂自动化数据收集器和网关
- 面向电网基础设施的数据集中器
- 无线转以太网网关

1.3 说明

SimpleLink MSP432E401Y ARM® Cortex®-M4F 微控制器具有顶级性能和高级集成功能。该产品系列用于需要强大的控制处理和连接功能且具有成本效益的应用。



MSP432E401Y 微控制器集成了大量丰富的通信特性，以实现全新的高度互连设计，在性能和功耗之间实现重要的实时控制。这些微控制器具有集成式通信外设以及其他高性能的模拟和数字功能，为开发从人机界面 (HMI) 到联网系统管理控制器在内的许多不同目标应用奠定了坚实的基础。

此外，MSP432E401Y 微控制器为基于 ARM 的微控制器提供了诸多优势，如广泛可用的开发工具、片上系统 (SoC) 基础架构，以及一个庞大的用户社区。另外，这些微控制器使用 ARM Thumb®兼容的 Thumb-2® 指令集来减少内存要求，并以此达到降低成本的目的。当使用 SimpleLink MSP432™SDK 时，MSP432E401Y 与 SimpleLink 系列的所有成员的代码兼容，因此使用灵活，可满足各类具体需求。

MSP432E401Y 器件是 SimpleLink 微控制器 (MCU) 平台的一部分，该平台包含 Wi-Fi®、低功耗 Bluetooth®、低于 1GHz、以太网、Zigbee、线程和主机 MCU，它们均共用一个通用、简单易用的开发环境，其中包含单核软件开发套件 (SDK) 和丰富的工具集。借助一次性集成的 SimpleLink 平台，可以将产品组合中的任何器件组合添加至您的设计中，从而在设计要求变更时实现 100% 代码重用。更多详细信息，请访问 www.ti.com/simplelink。

Device Information⁽¹⁾

PART NUMBER	PACKAGE	封装尺寸
MSP432E401YTPDT	TQFP (128)	14mm x 14mm

(1) 更多信息，请参见 节 9，机械、封装和可订购产品信息。

1.4 功能框图

图 1-1 给出了功能框图。

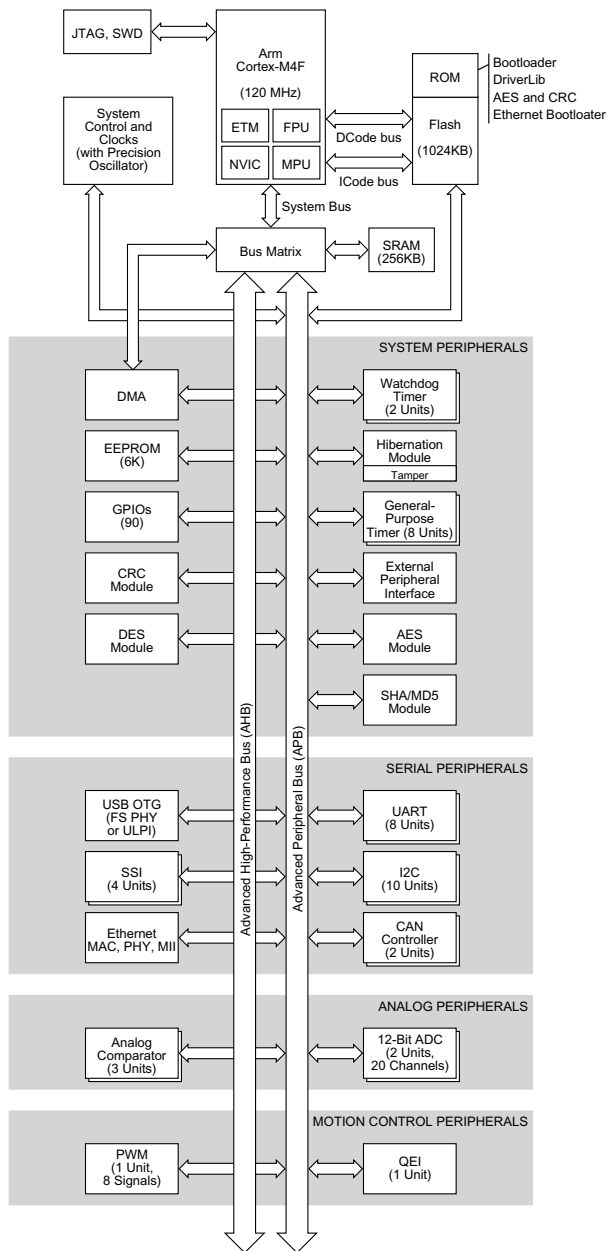

Copyright © 2017, Texas Instruments Incorporated

图 1-1. MSP432E401Y 功能方框图

内容

1	器件概述	1	5.11	Peripheral Current Consumption	41
1.1	特性	1	5.12	LDO Regulator Characteristics	41
1.2	应用	1	5.13	Power Dissipation	42
1.3	说明	1	5.14	Thermal Resistance Characteristics, 128-Pin PDT (TQFP) Package	42
1.4	功能框图	3	5.15	Timing and Switching Characteristics	43
2	Revision History	5	6	Detailed Description	94
3	Device Characteristics	6	6.1	Overview	94
3.1	Related Products	7	6.2	Functional Block Diagram	95
4	Terminal Configuration and Functions	8	6.3	Arm Cortex-M4F Processor Core	96
4.1	Pin Diagram	8	6.4	On-Chip Memory	100
4.2	Pin Attributes	9	6.5	Peripherals	102
4.3	Signal Descriptions	19	6.6	Identification	144
4.4	GPIO Pin Multiplexing	30	6.7	Boot Modes	144
4.5	Buffer Type	33	7	Applications, Implementation, and Layout	146
4.6	Connections for Unused Pins	33	7.1	System Design Guidelines	146
5	Specifications	35	8	器件和文档支持	147
5.1	Absolute Maximum Ratings	35	8.1	入门和后续步骤	147
5.2	ESD Ratings	35	8.2	器件命名规则	147
5.3	Recommended Operating Conditions	35	8.3	工具和软件	148
5.4	Recommended DC Operating Conditions	35	8.4	文档支持	149
5.5	Recommended GPIO Operating Characteristics ...	35	8.5	Community Resources	150
5.6	Recommended Fast GPIO Pad Operating Conditions	36	8.6	商标	150
5.7	Recommended Slow GPIO Pad Operating Conditions	36	8.7	静电放电警告	150
5.8	GPIO Current Restrictions	37	8.8	出口管制提示	150
5.9	I/O Reliability	37	8.9	术语表	150
5.10	Current Consumption	38	9	机械、封装和可订购信息	151

2 Revision History

注：之前版本的页码可能与当前版本有所不同。

DATE	REVISION	NOTES
2017 年 10 月	*	初始发行版

3 Device Characteristics

表 3-1 lists the characteristics of the MSP432E401Y MCU.

表 3-1. Device Characteristics

Feature	Description
Performance	
Core	Arm Cortex-M4F processor core
Performance	120-MHz operation, 150-DMIPS performance
Flash	1024KB of flash memory
System SRAM	256KB of single-cycle system SRAM
EEPROM	6KB of EEPROM
Internal ROM	Internal ROM loaded with SimpleLink SDK software
External Peripheral Interface (EPI)	8-, 16-, or 32-bit dedicated interface for peripherals and memory
Security	
Cyclical Redundancy Check (CRC)	16- or 32-bit hash function that supports four CRC forms
Advanced Encryption Standard (AES)	Hardware accelerated data encryption and decryption based on 128-, 192-, and 256-bit keys
Data Encryption Standard (DES)	Block cipher implementation with 168-bit effective key length
Hardware Accelerated Hash (SHA/MD5)	Advanced hash engine that supports SHA-1, SHA-2, or MD5 hash computation
Tamper	Support for four tamper inputs and configurable tamper event response
Communication Interfaces	
Universal Asynchronous Receiver/Transmitter (UART)	Eight UARTs
Quad Synchronous Serial Interface (QSSI)	Four SSI modules with bi-, quad-, and advanced-SSI support
Inter-Integrated Circuit (I ² C)	Ten I ² C modules with four transmission speeds including high-speed mode
Controller Area Network (CAN)	Two CAN 2.0 A/B controllers
Ethernet MAC	10/100 Ethernet MAC
Ethernet PHY	PHY with IEEE 1588 PTP hardware support
Universal Serial Bus (USB)	USB 2.0 OTG, Host, and Device with ULPI interface option and Link Power Management (LPM) support
System Integration	
Micro Direct Memory Access (μDMA)	Arm PrimeCell® 32-channel configurable μDMA controller
General-Purpose Timer (GPTM)	Eight 16- or 32-bit GPTM blocks
Watchdog Timer (WDT)	Two watchdog timers
Hibernation Module (HIB)	Low-power battery-backed Hibernation module
General-Purpose Input/Output (GPIO)	15 physical GPIO blocks
Advanced Motion Control	
Pulse Width Modulator (PWM)	One PWM module, with four PWM generator blocks and a control block, for a total of 8 PWM outputs
Quadrature Encoder Interface (QEI)	One QEI module
Analog Support	
Analog-to-Digital Converter (ADC)	Two 12-bit ADC modules, each with a maximum sample rate of 2 Msps
Analog Comparator Controller	Three independent integrated analog comparators
Digital Comparator	16 digital comparators
System Management	
JTAG and Serial Wire Debug (SWD)	One JTAG module with integrated Arm SWD
Package Information	
Package	128-pin TQFP (PDT)
Operating Range (Ambient)	Extended temperature range (–40°C to 105°C)

3.1 Related Products

For information about other devices in this family of products or related products, see the following links.

Products for TI Microcontrollers Low-power and high-performance MCUs, with wired and wireless connectivity options.

Products for SimpleLink MSP432 MCUs SimpleLink MSP432 MCUs with an ultra-low-power Arm Cortex-M4 core are optimized for Internet-of-Things sensor node applications. With an integrated ADC, the family enables acquisition and processing of high-precision signals without sacrificing power and is an optimal host MCU for TI's SimpleLink wireless connectivity solutions.

Companion Products for MSP432E401Y Review products that are frequently purchased or used with this product.

Reference Designs The TI Designs Reference Design Library is a robust reference design library that spans analog, embedded processor, and connectivity. Created by TI experts to help you jump start your system design, all TI Designs include schematic or block diagrams, BOMs, and design files to speed your time to market.

4 Terminal Configuration and Functions

4.1 Pin Diagram

图 4-1 shows the pinout of the 128-pin TQFP (PDT) package.

Each GPIO signal is identified by its GPIO port unless it defaults to an alternate function on reset. In this case, the GPIO port name is followed by the default alternate function. For a complete list of functions for each pin, see 表 4-2.



图 4-1. 128-Pin PDT Package (Top View)

4.2 Pin Attributes

表 4-1 lists GPIO pins with special considerations. Most GPIO pins are configured as GPIOs and are high-impedance by default (GPIOAFSEL = 0, GPIODEN = 0, GPIOPDR = 0, GPIOPUR = 0, and GPIOPCTL = 0). Special consideration pins may be programmed to a non-GPIO function or may have special commit controls out of reset. In addition, a POR returns these GPIOs to their original special consideration state.

表 4-1. GPIO Pins With Special Considerations

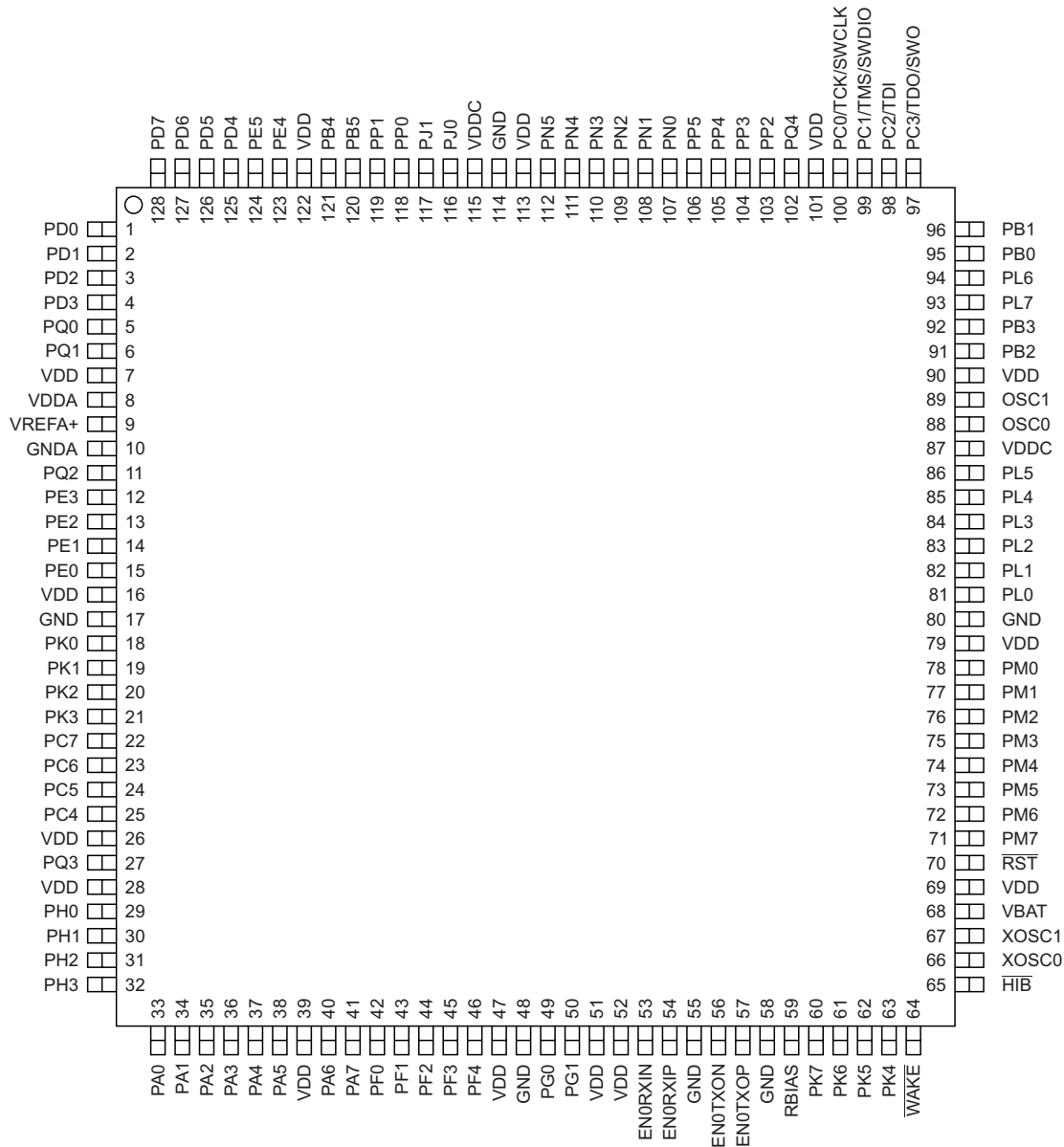
GPIO PINS	DEFAULT RESET STATE	GPIOAFSEL	GPIODEN	GPIOPDR	GPIOPUR	GPIOPCTL	GPIOCR
PC[3:0]	JTAG/SWD	1	1	0	1	0x1	0
PD[7]	GPIO ⁽¹⁾	0	0	0	0	0x0	0
PE[7]	GPIO ⁽¹⁾	0	0	0	0	0x0	0

(1) This pin is configured as a GPIO by default but is locked and can only be reprogrammed by unlocking the pin in the GPIOLOCK register and uncommitting it by setting the GPIOCR register.

表 4-2 describes the pin attributes.

表 4-2. Pin Attributes

PIN NUMBER	SIGNAL NAME	SIGNAL TYPE ⁽¹⁾	BUFFER TYPE ⁽²⁾	PIN MUX ENCODING	POWER SOURCE ⁽³⁾	STATE AFTER RESET RELEASE ⁽⁴⁾
1	PD0	I/O	LVC MOS	–	VDD	OFF
	AIN15	I	Analog	PD0		N/A
	C0o	O	LVC MOS	PD0 (5)		N/A
	I2C7SCL	I/O	LVC MOS	PD0 (2)		N/A
	SSI2XDAT1	I/O	LVC MOS	PD0 (15)		N/A
	T0CCP0	I/O	LVC MOS	PD0 (3)		N/A
2	PD1	I/O	LVC MOS	–	VDD	OFF
	AIN14	I	Analog	PD1		N/A
	C1o	O	LVC MOS	PD1 (5)		N/A
	I2C7SDA	I/O	LVC MOS	PD1 (2)		N/A
	SSI2XDAT0	I/O	LVC MOS	PD1 (15)		N/A
	T0CCP1	I/O	LVC MOS	PD1 (3)		N/A
3	PD2	I/O	LVC MOS	–	VDD	OFF
	AIN13	I	Analog	PD2		N/A
	C2o	O	LVC MOS	PD2 (5)		N/A
	I2C8SCL	I/O	LVC MOS	PD2 (2)		N/A
	SSI2Fss	I/O	LVC MOS	PD2 (15)		N/A
	T1CCP0	I/O	LVC MOS	PD2 (3)		N/A
4	PD3	I/O	LVC MOS	–	VDD	OFF
	AIN12	I	Analog	PD3		N/A
	I2C8SDA	I/O	LVC MOS	PD3 (2)		N/A
	SSI2CIk	I/O	LVC MOS	PD3 (15)		N/A
	T1CCP1	I/O	LVC MOS	PD3 (3)		N/A
5	PQ0	I/O	LVC MOS	–	VDD	OFF
	EPI0S20	I/O	LVC MOS	PQ0 (15)		N/A
	SSI3CIk	I/O	LVC MOS	PQ0 (14)		N/A

(1) Signal Types: I = Input, O = Output, I/O = Input or Output.

(2) For details on buffer types, see 表 4-5.

(3) N/A = Not applicable

(4) State after reset release: PU = High impedance with an active pullup resistor, OFF = High impedance, N/A = not applicable

表 4-2. Pin Attributes (continued)

PIN NUMBER	SIGNAL NAME	SIGNAL TYPE ⁽¹⁾	BUFFER TYPE ⁽²⁾	PIN MUX ENCODING	POWER SOURCE ⁽³⁾	STATE AFTER RESET RELEASE ⁽⁴⁾
6	PQ1	I/O	LVC MOS	–	VDD	OFF
	EPI0S21	I/O	LVC MOS	PQ1 (15)		N/A
	SSI3Fss	I/O	LVC MOS	PQ1 (14)		N/A
7	VDD	–	Power	Fixed	N/A	N/A
8	VDDA	–	Power	Fixed	N/A	N/A
9	VREFA+	–	Analog	Fixed	N/A	N/A
10	GNDA	–	Power	Fixed	N/A	N/A
11	PQ2	I/O	LVC MOS	–	VDD	OFF
	EPI0S22	I/O	LVC MOS	PQ2 (15)		N/A
	SSI3XDAT0	I/O	LVC MOS	PQ2 (14)		N/A
12	PE3	I/O	LVC MOS	–	VDD	OFF
	AIN0	I	Analog	PE3		N/A
	U1DTR	O	LVC MOS	PE3 (1)		N/A
13	PE2	I/O	LVC MOS	–	VDD	OFF
	AIN1	I	Analog	PE2		N/A
	U1DCD	I	LVC MOS	PE2 (1)		N/A
14	PE1	I/O	LVC MOS	–	VDD	OFF
	AIN2	I	Analog	PE1		N/A
	U1DSR	I	LVC MOS	PE1 (1)		N/A
15	PE0	I/O	LVC MOS	–	VDD	OFF
	AIN3	I	Analog	PE0		N/A
	U1RTS	O	LVC MOS	PE0 (1)		N/A
16	VDD	–	Power	Fixed	N/A	N/A
17	GND	–	Power	Fixed	N/A	N/A
18	PK0	I/O	LVC MOS	–	VDD	OFF
	AIN16	I	Analog	PK0		N/A
	EPI0S0	I/O	LVC MOS	PK0 (15)		N/A
	U4Rx	I	LVC MOS	PK0 (1)		N/A
19	PK1	I/O	LVC MOS	–	VDD	OFF
	AIN17	I	Analog	PK1		N/A
	EPI0S1	I/O	LVC MOS	PK1 (15)		N/A
	U4Tx	O	LVC MOS	PK1 (1)		N/A
20	PK2	I/O	LVC MOS	–	VDD	OFF
	AIN18	I	Analog	PK2		N/A
	EPI0S2	I/O	LVC MOS	PK2 (15)		N/A
	U4RTS	O	LVC MOS	PK2 (1)		N/A
21	PK3	I/O	LVC MOS	–	VDD	OFF
	AIN19	I	Analog	PK3		N/A
	EPI0S3	I/O	LVC MOS	PK3 (15)		N/A
	U4CTS	I	LVC MOS	PK3 (1)		N/A
22	PC7	I/O	LVC MOS	–	VDD	OFF
	C0-	I	Analog	PC7		N/A
	EPI0S4	I/O	LVC MOS	PC7 (15)		N/A
	U5Tx	O	LVC MOS	PC7 (1)		N/A

表 4-2. Pin Attributes (continued)

PIN NUMBER	SIGNAL NAME	SIGNAL TYPE ⁽¹⁾	BUFFER TYPE ⁽²⁾	PIN MUX ENCODING	POWER SOURCE ⁽³⁾	STATE AFTER RESET RELEASE ⁽⁴⁾
23	PC6	I/O	LVC MOS	–	VDD	OFF
	C0+	I	Analog	PC6		N/A
	EPI0S5	I/O	LVC MOS	PC6 (15)		N/A
	U5Rx	I	LVC MOS	PC6 (1)		N/A
24	PC5	I/O	LVC MOS	–	VDD	OFF
	C1+	I	Analog	PC5		N/A
	EPI0S6	I/O	LVC MOS	PC5 (15)		N/A
	RTCCLK	O	LVC MOS	PC5 (7)		N/A
	U7Tx	O	LVC MOS	PC5 (1)		N/A
25	PC4	I/O	LVC MOS	–	VDD	OFF
	C1-	I	Analog	PC4		N/A
	EPI0S7	I/O	LVC MOS	PC4 (15)		N/A
	U7Rx	I	LVC MOS	PC4 (1)		N/A
26	VDD	–	Power	Fixed	N/A	N/A
27	PQ3	I/O	LVC MOS	–	VDD	OFF
	EPI0S23	I/O	LVC MOS	PQ3 (15)		N/A
	SSI3XDAT1	I/O	LVC MOS	PQ3 (14)		N/A
28	VDD	–	Power	Fixed	N/A	N/A
29	PH0	I/O	LVC MOS	–	VDD	OFF
	EPI0S0	I/O	LVC MOS	PH0 (15)		N/A
	U0RTS	O	LVC MOS	PH0 (1)		N/A
30	PH1	I/O	LVC MOS	–	VDD	OFF
	EPI0S1	I/O	LVC MOS	PH1 (15)		N/A
	U0CTS	I	LVC MOS	PH1 (1)		N/A
31	PH2	I/O	LVC MOS	–	VDD	OFF
	EPI0S2	I/O	LVC MOS	PH2 (15)		N/A
	U0DCD	I	LVC MOS	PH2 (1)		N/A
32	PH3	I/O	LVC MOS	–	VDD	OFF
	EPI0S3	I/O	LVC MOS	PH3 (15)		N/A
	U0DSR	I	LVC MOS	PH3 (1)		N/A
33	PA0	I/O	LVC MOS	–	VDD	OFF
	CAN0Rx	I	LVC MOS	PA0 (7)		N/A
	I2C9SCL	I/O	LVC MOS	PA0 (2)		N/A
	T0CCP0	I/O	LVC MOS	PA0 (3)		N/A
	U0Rx	I	LVC MOS	PA0 (1)		N/A
34	PA1	I/O	LVC MOS	–	VDD	OFF
	CAN0Tx	O	LVC MOS	PA1 (7)		N/A
	I2C9SDA	I/O	LVC MOS	PA1 (2)		N/A
	T0CCP1	I/O	LVC MOS	PA1 (3)		N/A
	U0Tx	O	LVC MOS	PA1 (1)		N/A
35	PA2	I/O	LVC MOS	–	VDD	OFF
	I2C8SCL	I/O	LVC MOS	PA2 (2)		N/A
	SSI0Cik	I/O	LVC MOS	PA2 (15)		N/A
	T1CCP0	I/O	LVC MOS	PA2 (3)		N/A
	U4Rx	I	LVC MOS	PA2 (1)		N/A

表 4-2. Pin Attributes (continued)

PIN NUMBER	SIGNAL NAME	SIGNAL TYPE ⁽¹⁾	BUFFER TYPE ⁽²⁾	PIN MUX ENCODING	POWER SOURCE ⁽³⁾	STATE AFTER RESET RELEASE ⁽⁴⁾
36	PA3	I/O	LVC MOS	–	VDD	OFF
	I2C8SDA	I/O	LVC MOS	PA3 (2)		N/A
	SSI0Fss	I/O	LVC MOS	PA3 (15)		N/A
	T1CCP1	I/O	LVC MOS	PA3 (3)		N/A
	U4Tx	O	LVC MOS	PA3 (1)		N/A
37	PA4	I/O	LVC MOS	–	VDD	OFF
	I2C7SCL	I/O	LVC MOS	PA4 (2)		N/A
	SSI0XDAT0	I/O	LVC MOS	PA4 (15)		N/A
	T2CCP0	I/O	LVC MOS	PA4 (3)		N/A
	U3Rx	I	LVC MOS	PA4 (1)		N/A
38	PA5	I/O	LVC MOS	–	VDD	OFF
	I2C7SDA	I/O	LVC MOS	PA5 (2)		N/A
	SSI0XDAT1	I/O	LVC MOS	PA5 (15)		N/A
	T2CCP1	I/O	LVC MOS	PA5 (3)		N/A
	U3Tx	O	LVC MOS	PA5 (1)		N/A
39	VDD	–	Power	Fixed	N/A	N/A
40	PA6	I/O	LVC MOS	–	VDD	OFF
	EPI0S8	I/O	LVC MOS	PA6 (15)		N/A
	I2C6SCL	I/O	LVC MOS	PA6 (2)		N/A
	SSI0XDAT2	I/O	LVC MOS	PA6 (13)		N/A
	T3CCP0	I/O	LVC MOS	PA6 (3)		N/A
	U2Rx	I	LVC MOS	PA6 (1)		N/A
	USB0EPEN	O	LVC MOS	PA6 (5)		N/A
41	PA7	I/O	LVC MOS	–	VDD	OFF
	EPI0S9	I/O	LVC MOS	PA7 (15)		N/A
	I2C6SDA	I/O	LVC MOS	PA7 (2)		N/A
	SSI0XDAT3	I/O	LVC MOS	PA7 (13)		N/A
	T3CCP1	I/O	LVC MOS	PA7 (3)		N/A
	U2Tx	O	LVC MOS	PA7 (1)		N/A
	USB0EPEN	O	LVC MOS	PA7 (11)		N/A
	USB0PFLT	I	LVC MOS	PA7 (5)		N/A
42	PF0	I/O	LVC MOS	–	VDD	OFF
	EN0LED0	O	LVC MOS	PF0 (5)		N/A
	M0PWM0	O	LVC MOS	PF0 (6)		N/A
	SSI3XDAT1	I/O	LVC MOS	PF0 (14)		N/A
	TRD2	O	LVC MOS	PF0 (15)		N/A
43	PF1	I/O	LVC MOS	–	VDD	OFF
	EN0LED2	O	LVC MOS	PF1 (5)		N/A
	M0PWM1	O	LVC MOS	PF1 (6)		N/A
	SSI3XDAT0	I/O	LVC MOS	PF1 (14)		N/A
	TRD1	O	LVC MOS	PF1 (15)		N/A
44	PF2	I/O	LVC MOS	–	VDD	OFF
	M0PWM2	O	LVC MOS	PF2 (6)		N/A
	SSI3Fss	I/O	LVC MOS	PF2 (14)		N/A
	TRD0	O	LVC MOS	PF2 (15)		N/A

表 4-2. Pin Attributes (continued)

PIN NUMBER	SIGNAL NAME	SIGNAL TYPE ⁽¹⁾	BUFFER TYPE ⁽²⁾	PIN MUX ENCODING	POWER SOURCE ⁽³⁾	STATE AFTER RESET RELEASE ⁽⁴⁾
45	PF3	I/O	LVC MOS	–	VDD	OFF
	M0PWM3	O	LVC MOS	PF3 (6)		N/A
	SSI3Cik	I/O	LVC MOS	PF3 (14)		N/A
	TRCLK	O	LVC MOS	PF3 (15)		N/A
46	PF4	I/O	LVC MOS	–	VDD	OFF
	EN0LED1	O	LVC MOS	PF4 (5)		N/A
	M0FAULT0	I	LVC MOS	PF4 (6)		N/A
	SSI3XDAT2	I/O	LVC MOS	PF4 (14)		N/A
	TRD3	O	LVC MOS	PF4 (15)		N/A
47	VDD	–	Power	Fixed	N/A	N/A
48	GND	–	Power	Fixed	N/A	N/A
49	PG0	I/O	LVC MOS	–	VDD	OFF
	EN0PPS	O	LVC MOS	PG0 (5)		N/A
	EPI0S11	I/O	LVC MOS	PG0 (15)		N/A
	I2C1SCL	I/O	LVC MOS	PG0 (2)		N/A
	M0PWM4	O	LVC MOS	PG0 (6)		N/A
50	PG1	I/O	LVC MOS	–	VDD	OFF
	EPI0S10	I/O	LVC MOS	PG1 (15)		N/A
	I2C1SDA	I/O	LVC MOS	PG1 (2)		N/A
	M0PWM5	O	LVC MOS	PG1 (6)		N/A
51	VDD	–	Power	Fixed	N/A	N/A
52	VDD	–	Power	Fixed	N/A	N/A
53	EN0RXIN	I/O	LVC MOS	Fixed	VDD	N/A
54	EN0RXIP	I/O	LVC MOS	Fixed	VDD	N/A
55	GND	–	Power	Fixed	N/A	N/A
56	EN0TXON	I/O	LVC MOS	Fixed	VDD	N/A
57	EN0TXOP	I/O	LVC MOS	Fixed	VDD	N/A
58	GND	–	Power	Fixed	N/A	N/A
59	RBIAS	O	Analog	Fixed	VDD	N/A
60	PK7	I/O	LVC MOS	–	VDD	OFF
	EPI0S24	I/O	LVC MOS	PK7 (15)		N/A
	I2C4SDA	I/O	LVC MOS	PK7 (2)		N/A
	M0FAULT2	I	LVC MOS	PK7 (6)		N/A
	RTCCLK	O	LVC MOS	PK7 (5)		N/A
	U0RI	I	LVC MOS	PK7 (1)		N/A
61	PK6	I/O	LVC MOS	–	VDD	OFF
	EN0LED1	O	LVC MOS	PK6 (5)		N/A
	EPI0S25	I/O	LVC MOS	PK6 (15)		N/A
	I2C4SCL	I/O	LVC MOS	PK6 (2)		N/A
	M0FAULT1	I	LVC MOS	PK6 (6)		N/A
62	PK5	I/O	LVC MOS	–	VDD	OFF
	EN0LED2	O	LVC MOS	PK5 (5)		N/A
	EPI0S31	I/O	LVC MOS	PK5 (15)		N/A
	I2C3SDA	I/O	LVC MOS	PK5 (2)		N/A
	M0PWM7	O	LVC MOS	PK5 (6)		N/A

表 4-2. Pin Attributes (continued)

PIN NUMBER	SIGNAL NAME	SIGNAL TYPE ⁽¹⁾	BUFFER TYPE ⁽²⁾	PIN MUX ENCODING	POWER SOURCE ⁽³⁾	STATE AFTER RESET RELEASE ⁽⁴⁾
63	PK4	I/O	LVC MOS	–	VDD	OFF
	EN0LED0	O	LVC MOS	PK4 (5)		N/A
	EPI0S32	I/O	LVC MOS	PK4 (15)		N/A
	I2C3SCL	I/O	LVC MOS	PK4 (2)		N/A
	MOPWM6	O	LVC MOS	PK4 (6)		N/A
64	WAKE	I	LVC MOS	Fixed	VBAT	N/A
65	HIB	O	LVC MOS	Fixed	VBAT	N/A
66	XOSC0	I	Analog	Fixed	VBAT	N/A
67	XOSC1	O	Analog	Fixed	VBAT	N/A
68	VBAT	–	Power	Fixed	N/A	N/A
69	VDD	–	Power	Fixed	N/A	N/A
70	RST	I	LVC MOS	Fixed	VDD	N/A
71	PM7	I/O	LVC MOS	–	VDD	OFF
	T5CCP1	I/O	LVC MOS	PM7 (3)		N/A
	TMPR0	I/O	LVC MOS	PM7		N/A
	U0RI	I	LVC MOS	PM7 (1)		N/A
72	PM6	I/O	LVC MOS	–	VDD	OFF
	T5CCP0	I/O	LVC MOS	PM6 (3)		N/A
	TMPR1	I/O	LVC MOS	PM6		N/A
	U0DSR	I	LVC MOS	PM6 (1)		N/A
73	PM5	I/O	LVC MOS	–	VDD	OFF
	T4CCP1	I/O	LVC MOS	PM5 (3)		N/A
	TMPR2	I/O	LVC MOS	PM5		N/A
	U0DCD	I	LVC MOS	PM5 (1)		N/A
74	PM4	I/O	LVC MOS	–	VDD	OFF
	T4CCP0	I/O	LVC MOS	PM4 (3)		N/A
	TMPR3	I/O	LVC MOS	PM4		N/A
	U0CTS	I	LVC MOS	PM4 (1)		N/A
75	PM3	I/O	LVC MOS	–	VDD	OFF
	EPI0S12	I/O	LVC MOS	PM3 (15)		N/A
	T3CCP1	I/O	LVC MOS	PM3 (3)		N/A
76	PM2	I/O	LVC MOS	–	VDD	OFF
	EPI0S13	I/O	LVC MOS	PM2 (15)		N/A
	T3CCP0	I/O	LVC MOS	PM2 (3)		N/A
77	PM1	I/O	LVC MOS	–	VDD	OFF
	EPI0S14	I/O	LVC MOS	PM1 (15)		N/A
	T2CCP1	I/O	LVC MOS	PM1 (3)		N/A
78	PM0	I/O	LVC MOS	–	VDD	OFF
	EPI0S15	I/O	LVC MOS	PM0 (15)		N/A
	T2CCP0	I/O	LVC MOS	PM0 (3)		N/A
79	VDD	–	Power	Fixed	N/A	N/A
80	GND	–	Power	Fixed	N/A	N/A

表 4-2. Pin Attributes (continued)

PIN NUMBER	SIGNAL NAME	SIGNAL TYPE ⁽¹⁾	BUFFER TYPE ⁽²⁾	PIN MUX ENCODING	POWER SOURCE ⁽³⁾	STATE AFTER RESET RELEASE ⁽⁴⁾
81	PL0	I/O	LVC MOS	–	VDD	OFF
	EPI0S16	I/O	LVC MOS	PL0 (15)		N/A
	I2C2SDA	I/O	LVC MOS	PL0 (2)		N/A
	M0FAULT3	I	LVC MOS	PL0 (6)		N/A
	USB0D0	I/O	LVC MOS	PL0 (14)		N/A
82	PL1	I/O	LVC MOS	–	VDD	OFF
	EPI0S17	I/O	LVC MOS	PL1 (15)		N/A
	I2C2SCL	I/O	LVC MOS	PL1 (2)		N/A
	PhA0	I	LVC MOS	PL1 (6)		N/A
	USB0D1	I/O	LVC MOS	PL1 (14)		N/A
83	PL2	I/O	LVC MOS	–	VDD	OFF
	C0o	O	LVC MOS	PL2 (5)		N/A
	EPI0S18	I/O	LVC MOS	PL2 (15)		N/A
	PhB0	I	LVC MOS	PL2 (6)		N/A
	USB0D2	I/O	LVC MOS	PL2 (14)		N/A
84	PL3	I/O	LVC MOS	–	VDD	OFF
	C1o	O	LVC MOS	PL3 (5)		N/A
	EPI0S19	I/O	LVC MOS	PL3 (15)		N/A
	IDX0	I	LVC MOS	PL3 (6)		N/A
	USB0D3	I/O	LVC MOS	PL3 (14)		N/A
85	PL4	I/O	LVC MOS	–	VDD	OFF
	EPI0S26	I/O	LVC MOS	PL4 (15)		N/A
	T0CCP0	I/O	LVC MOS	PL4 (3)		N/A
	USB0D4	I/O	LVC MOS	PL4 (14)		N/A
86	PL5	I/O	LVC MOS	–	VDD	OFF
	EPI0S33	I/O	LVC MOS	PL5 (15)		N/A
	T0CCP1	I/O	LVC MOS	PL5 (3)		N/A
	USB0D5	I/O	LVC MOS	PL5 (14)		N/A
87	VDDC	–	Power	Fixed	N/A	N/A
88	OSC0	I	Analog	Fixed	VDD	N/A
89	OSC1	O	Analog	Fixed	VDD	N/A
90	VDD	–	Power	Fixed	N/A	N/A
91	PB2	I/O	LVC MOS	–	VDD	OFF
	EPI0S27	I/O	LVC MOS	PB2 (15)		N/A
	I2C0SCL	I/O	LVC MOS	PB2 (2)		N/A
	T5CCP0	I/O	LVC MOS	PB2 (3)		N/A
	USB0STP	O	LVC MOS	PB2 (14)		N/A
92	PB3	I/O	LVC MOS	–	VDD	OFF
	EPI0S28	I/O	LVC MOS	PB3 (15)		N/A
	I2C0SDA	I/O	LVC MOS	PB3 (2)		N/A
	T5CCP1	I/O	LVC MOS	PB3 (3)		N/A
	USB0CLK	O	LVC MOS	PB3 (14)		N/A
93	PL7	I/O	LVC MOS	–	VDD	OFF
	T1CCP1	I/O	LVC MOS	PL7 (3)		N/A
	USB0DM	I/O	Analog	PL7		N/A

表 4-2. Pin Attributes (continued)

PIN NUMBER	SIGNAL NAME	SIGNAL TYPE ⁽¹⁾	BUFFER TYPE ⁽²⁾	PIN MUX ENCODING	POWER SOURCE ⁽³⁾	STATE AFTER RESET RELEASE ⁽⁴⁾
94	PL6	I/O	LVC MOS	–	VDD	OFF
	T1CCP0	I/O	LVC MOS	PL6 (3)		N/A
	USB0DP	I/O	Analog	PL6		N/A
95	PB0	I/O	LVC MOS	–	VDD	OFF
	CAN1Rx	I	LVC MOS	PB0 (7)		N/A
	I2C5SCL	I/O	LVC MOS	PB0 (2)		N/A
	T4CCP0	I/O	LVC MOS	PB0 (3)		N/A
	U1Rx	I	LVC MOS	PB0 (1)		N/A
	USB0ID	I	Analog	PB0		N/A
96	PB1	I/O	LVC MOS	–	VDD	OFF
	CAN1Tx	O	LVC MOS	PB1 (7)		N/A
	I2C5SDA	I/O	LVC MOS	PB1 (2)		N/A
	T4CCP1	I/O	LVC MOS	PB1 (3)		N/A
	U1Tx	O	LVC MOS	PB1 (1)		N/A
	USB0VBUS	I/O	Analog	PB1		N/A
97	PC3	I/O	LVC MOS	–	VDD	OFF
	TDO/SWO	O	LVC MOS	PC3 (1)		PU
98	PC2	I/O	LVC MOS	–	VDD	N/A
	TDI	I	LVC MOS	PC2 (1)		PU
99	PC1	I/O	LVC MOS	–	VDD	OFF
	TMS/SWDIO	I/O	LVC MOS	PC1 (1)		PU
100	PC0	I/O	LVC MOS	–	VDD	OFF
	TCK/SWCLK	I	LVC MOS	PC0 (1)		PU
101	VDD	–	Power	Fixed	N/A	N/A
102	PQ4	I/O	LVC MOS	–	VDD	OFF
	DIVSCLK	O	LVC MOS	PQ4 (7)		N/A
	U1Rx	I	LVC MOS	PQ4 (1)		N/A
103	PP2	I/O	LVC MOS	–	VDD	OFF
	EPI0S29	I/O	LVC MOS	PP2 (15)		N/A
	U0DTR	O	LVC MOS	PP2 (1)		N/A
	USB0NXT	O	LVC MOS	PP2 (14)		N/A
104	PP3	I/O	LVC MOS	–	VDD	OFF
	EPI0S30	I/O	LVC MOS	PP3 (15)		N/A
	RTCCLK	O	LVC MOS	PP3 (7)		N/A
	U0DCD	I	LVC MOS	PP3 (2)		N/A
	U1CTS	I	LVC MOS	PP3 (1)		N/A
	USB0DIR	O	LVC MOS	PP3 (14)		N/A
105	PP4	I/O	LVC MOS	–	VDD	OFF
	U0DSR	I	LVC MOS	PP4 (2)		N/A
	U3RTS	O	LVC MOS	PP4 (1)		N/A
	USB0D7	I/O	LVC MOS	PP4 (14)		N/A
106	PP5	I/O	LVC MOS	–	VDD	OFF
	I2C2SCL	I/O	LVC MOS	PP5 (2)		N/A
	U3CTS	I	LVC MOS	PP5 (1)		N/A
	USB0D6	I/O	LVC MOS	PP5 (14)		N/A

表 4-2. Pin Attributes (continued)

PIN NUMBER	SIGNAL NAME	SIGNAL TYPE ⁽¹⁾	BUFFER TYPE ⁽²⁾	PIN MUX ENCODING	POWER SOURCE ⁽³⁾	STATE AFTER RESET RELEASE ⁽⁴⁾
107	PN0	I/O	LVC MOS	–	VDD	OFF
	U1RTS	O	LVC MOS	PN0 (1)		N/A
108	PN1	I/O	LVC MOS	–	VDD	OFF
	U1CTS	I	LVC MOS	PN1 (1)		N/A
109	PN2	I/O	LVC MOS	–	VDD	OFF
	EPI0S29	I/O	LVC MOS	PN2 (15)		N/A
	U1DCD	I	LVC MOS	PN2 (1)		N/A
	U2RTS	O	LVC MOS	PN2 (2)		N/A
110	PN3	I/O	LVC MOS	–	VDD	OFF
	EPI0S30	I/O	LVC MOS	PN3 (15)		N/A
	U1DSR	I	LVC MOS	PN3 (1)		N/A
	U2CTS	I	LVC MOS	PN3 (2)		N/A
111	PN4	I/O	LVC MOS	–	VDD	OFF
	EPI0S34	I/O	LVC MOS	PN4 (15)		N/A
	I2C2SDA	I/O	LVC MOS	PN4 (3)		N/A
	U1DTR	O	LVC MOS	PN4 (1)		N/A
	U3RTS	O	LVC MOS	PN4 (2)		N/A
112	PN5	I/O	LVC MOS	–	VDD	OFF
	EPI0S35	I/O	LVC MOS	PN5 (15)		N/A
	I2C2SCL	I/O	LVC MOS	PN5 (3)		N/A
	U1RI	I	LVC MOS	PN5 (1)		N/A
	U3CTS	I	LVC MOS	PN5 (2)		N/A
113	VDD	–	Power	Fixed	N/A	N/A
114	GND	–	Power	Fixed	N/A	N/A
115	VDDC	–	Power	Fixed	N/A	N/A
116	PJ0	I/O	LVC MOS	–	VDD	OFF
	EN0PPS	O	LVC MOS	PJ0 (5)		N/A
	U3Rx	I	LVC MOS	PJ0 (1)		N/A
117	PJ1	I/O	LVC MOS	–	VDD	OFF
	U3Tx	O	LVC MOS	PJ1 (1)		N/A
118	PP0	I/O	LVC MOS	–	VDD	OFF
	C2+	I	Analog	PP0		N/A
	SSI3XDAT2	I/O	LVC MOS	PP0 (15)		N/A
	U6Rx	I	LVC MOS	PP0 (1)		N/A
119	PP1	I/O	LVC MOS	–	VDD	OFF
	C2-	I	Analog	PP1		N/A
	SSI3XDAT3	I/O	LVC MOS	PP1 (15)		N/A
	U6Tx	O	LVC MOS	PP1 (1)		N/A
120	PB5	I/O	LVC MOS	–	VDD	OFF
	AIN11	I	Analog	PB5		N/A
	I2C5SDA	I/O	LVC MOS	PB5 (2)		N/A
	SSI1Cik	I/O	LVC MOS	PB5 (15)		N/A
	U0RTS	O	LVC MOS	PB5 (1)		N/A

表 4-2. Pin Attributes (continued)

PIN NUMBER	SIGNAL NAME	SIGNAL TYPE ⁽¹⁾	BUFFER TYPE ⁽²⁾	PIN MUX ENCODING	POWER SOURCE ⁽³⁾	STATE AFTER RESET RELEASE ⁽⁴⁾
121	PB4	I/O	LVC MOS	–	VDD	OFF
	AIN10	I	Analog	PB4		N/A
	I2C5SCL	I/O	LVC MOS	PB4 (2)		N/A
	SSI1Fss	I/O	LVC MOS	PB4 (15)		N/A
	U0CTS	I	LVC MOS	PB4 (1)		N/A
122	VDD	–	Power	Fixed	N/A	N/A
123	PE4	I/O	LVC MOS	–	VDD	OFF
	AIN9	I	Analog	PE4		N/A
	SSI1XDAT0	I/O	LVC MOS	PE4 (15)		N/A
	U1RI	I	LVC MOS	PE4 (1)		N/A
124	PE5	I/O	LVC MOS	–	VDD	OFF
	AIN8	I	Analog	PE5		N/A
	SSI1XDAT1	I/O	LVC MOS	PE5 (15)		N/A
125	PD4	I/O	LVC MOS	–	VDD	OFF
	AIN7	I	Analog	PD4		N/A
	SSI1XDAT2	I/O	LVC MOS	PD4 (15)		N/A
	T3CCP0	I/O	LVC MOS	PD4 (3)		N/A
	U2Rx	I	LVC MOS	PD4 (1)		N/A
126	PD5	I/O	LVC MOS	–	VDD	OFF
	AIN6	I	Analog	PD5		N/A
	SSI1XDAT3	I/O	LVC MOS	PD5 (15)		N/A
	T3CCP1	I/O	LVC MOS	PD5 (3)		N/A
	U2Tx	O	LVC MOS	PD5 (1)		N/A
127	PD6	I/O	LVC MOS	–	VDD	OFF
	AIN5	I	Analog	PD6		N/A
	SSI2XDAT3	I/O	LVC MOS	PD6 (15)		N/A
	T4CCP0	I/O	LVC MOS	PD6 (3)		N/A
	U2RTS	O	LVC MOS	PD6 (1)		N/A
	USB0EPEN	O	LVC MOS	PD6 (5)		N/A
128	PD7	I/O	LVC MOS	–	VDD	OFF
	AIN4	I	Analog	PD7		N/A
	NMI	I	LVC MOS	PD7 (8)		N/A
	SSI2XDAT2	I/O	LVC MOS	PD7 (15)		N/A
	T4CCP1	I/O	LVC MOS	PD7 (3)		N/A
	U2CTS	I	LVC MOS	PD7 (1)		N/A
	USB0PFLT	I	LVC MOS	PD7 (5)		N/A

4.3 Signal Descriptions

表 4-3 describes the signals. The signals are sorted by function.

表 4-3. Signal Descriptions

FUNCTION	SIGNAL NAME	PIN NO.	PIN TYPE	DESCRIPTION
ADC	AIN0	12	I	Analog-to-digital converter input 0.
	AIN1	13	I	Analog-to-digital converter input 1
	AIN2	14	I	Analog-to-digital converter input 2
	AIN3	15	I	Analog-to-digital converter input 3
	AIN4	128	I	Analog-to-digital converter input 4
	AIN5	127	I	Analog-to-digital converter input 5
	AIN6	126	I	Analog-to-digital converter input 6
	AIN7	125	I	Analog-to-digital converter input 7
	AIN8	124	I	Analog-to-digital converter input 8
	AIN9	123	I	Analog-to-digital converter input 9
	AIN10	121	I	Analog-to-digital converter input 10
	AIN11	120	I	Analog-to-digital converter input 11
	AIN12	4	I	Analog-to-digital converter input 12
	AIN13	3	I	Analog-to-digital converter input 13
	AIN14	2	I	Analog-to-digital converter input 14
	AIN15	1	I	Analog-to-digital converter input 15
	AIN16	18	I	Analog-to-digital converter input 16
	AIN17	19	I	Analog-to-digital converter input 17
	AIN18	20	I	Analog-to-digital converter input 18
	AIN19	21	I	Analog-to-digital converter input 19
	VREFA+	9	-	A reference voltage used to specify the voltage at which the ADC converts to a maximum value. This pin is used in conjunction with GNDA. The voltage that is applied to VREFA+ is the voltage with which an AINn signal is converted to 4095. The VREFA+ voltage is limited to the range specified in the ADC electrical specifications.
Analog Comparators	C0+	23	I	Analog comparator 0 positive input
	C0-	22	I	Analog comparator 0 negative input
	C0o	1 83	O	Analog comparator 0 output
	C1+	24	I	Analog comparator 1 positive input
	C1-	25	I	Analog comparator 1 negative input
	C1o	2 84	O	Analog comparator 1 output
	C2+	118	I	Analog comparator 2 positive input
	C2-	119	I	Analog comparator 2 negative input
	C2o	3	O	Analog comparator 2 output
Controller Area Network	CAN0Rx	33	I	CAN module 0 receive
	CAN0Tx	34	O	CAN module 0 transmit
	CAN1Rx	95	I	CAN module 1 receive
	CAN1Tx	96	O	CAN module 1 transmit

表 4-3. Signal Descriptions (continued)

FUNCTION	SIGNAL NAME	PIN NO.	PIN TYPE	DESCRIPTION
Core	TRCLK	45	O	Trace clock.
	TRD0	44	O	Trace data 0.
	TRD1	43	O	Trace data 1.
	TRD2	42	O	Trace data 2.
	TRD3	46	O	Trace data 3.
Ethernet	EN0LED0	42 63	O	Ethernet 0 LED 0
	EN0LED1	46 61	O	Ethernet 0 LED 1
	EN0LED2	43 62	O	Ethernet 0 LED 2
	EN0PPS	49 116	O	Ethernet 0 pulse-per-second (PPS) output
	EN0RXIN	53	I/O	Ethernet PHY negative receive differential input
	EN0RXIP	54	I/O	Ethernet PHY positive receive differential input
	EN0TXON	56	I/O	Ethernet PHY negative transmit differential output
	EN0TXOP	57	I/O	Ethernet PHY positive transmit differential output
RBIAS	59	O	4.87-k Ω resistor (1% precision) for Ethernet PHY	

表 4-3. Signal Descriptions (continued)

FUNCTION	SIGNAL NAME	PIN NO.	PIN TYPE	DESCRIPTION
External Peripheral Interface	EPI0S0	18 29	I/O	EPI module 0 signal 0
	EPI0S1	19 30	I/O	EPI module 0 signal 1
	EPI0S2	20 31	I/O	EPI module 0 signal 2
	EPI0S3	21 32	I/O	EPI module 0 signal 3
	EPI0S4	22	I/O	EPI module 0 signal 4
	EPI0S5	23	I/O	EPI module 0 signal 5
	EPI0S6	24	I/O	EPI module 0 signal 6
	EPI0S7	25	I/O	EPI module 0 signal 7
	EPI0S8	40	I/O	EPI module 0 signal 8
	EPI0S9	41	I/O	EPI module 0 signal 9
	EPI0S10	50	I/O	EPI module 0 signal 10
	EPI0S11	49	I/O	EPI module 0 signal 11
	EPI0S12	75	I/O	EPI module 0 signal 12
	EPI0S13	76	I/O	EPI module 0 signal 13
	EPI0S14	77	I/O	EPI module 0 signal 14
	EPI0S15	78	I/O	EPI module 0 signal 15
	EPI0S16	81	I/O	EPI module 0 signal 16
	EPI0S17	82	I/O	EPI module 0 signal 17
	EPI0S18	83	I/O	EPI module 0 signal 18
	EPI0S19	84	I/O	EPI module 0 signal 19
	EPI0S20	5	I/O	EPI module 0 signal 20
	EPI0S21	6	I/O	EPI module 0 signal 21
	EPI0S22	11	I/O	EPI module 0 signal 22
	EPI0S23	27	I/O	EPI module 0 signal 23
	EPI0S24	60	I/O	EPI module 0 signal 24
	EPI0S25	61	I/O	EPI module 0 signal 25
	EPI0S26	85	I/O	EPI module 0 signal 26
	EPI0S27	91	I/O	EPI module 0 signal 27
	EPI0S28	92	I/O	EPI module 0 signal 28
	EPI0S29	103 109	I/O	EPI module 0 signal 29
	EPI0S30	104 110	I/O	EPI module 0 signal 30
	EPI0S31	62	I/O	EPI module 0 signal 31
	EPI0S32	63	I/O	EPI module 0 signal 32
	EPI0S33	86	I/O	EPI module 0 signal 33
	EPI0S34	111	I/O	EPI module 0 signal 34
EPI0S35	112	I/O	EPI module 0 signal 35	

表 4-3. Signal Descriptions (continued)

FUNCTION	SIGNAL NAME	PIN NO.	PIN TYPE	DESCRIPTION
General-Purpose Timers	T0CCP0	1 33 85	I/O	16/32-Bit Timer 0 Capture/Compare/PWM 0
	T0CCP1	2 34 86	I/O	16/32-Bit Timer 0 Capture/Compare/PWM 1
	T1CCP0	3 35 94	I/O	16/32-Bit Timer 1 Capture/Compare/PWM 0
	T1CCP1	4 36 93	I/O	16/32-Bit Timer 1 Capture/Compare/PWM 1
	T2CCP0	37 78	I/O	16/32-Bit Timer 2 Capture/Compare/PWM 0
	T2CCP1	38 77	I/O	16/32-Bit Timer 2 Capture/Compare/PWM 1
	T3CCP0	40 76 125	I/O	16/32-Bit Timer 3 Capture/Compare/PWM 0
	T3CCP1	41 75 126	I/O	16/32-Bit Timer 3 Capture/Compare/PWM 1
	T4CCP0	74 95 127	I/O	16/32-Bit Timer 4 Capture/Compare/PWM 0
	T4CCP1	73 96 128	I/O	16/32-Bit Timer 4 Capture/Compare/PWM 1
	T5CCP0	72 91	I/O	16/32-Bit Timer 5 Capture/Compare/PWM 0
	T5CCP1	71 92	I/O	16/32-Bit Timer 5 Capture/Compare/PWM 1
GPIO, Port A	PA0	33	I/O	GPIO port A bit 0
	PA1	34	I/O	GPIO port A bit 1
	PA2	35	I/O	GPIO port A bit 2
	PA3	36	I/O	GPIO port A bit 3
	PA4	37	I/O	GPIO port A bit 4
	PA5	38	I/O	GPIO port A bit 5
	PA6	40	I/O	GPIO port A bit 6
	PA7	41	I/O	GPIO port A bit 7
GPIO, Port B	PB0	95	I/O	GPIO port B bit 0
	PB1	96	I/O	GPIO port B bit 1
	PB2	91	I/O	GPIO port B bit 2
	PB3	92	I/O	GPIO port B bit 3
	PB4	121	I/O	GPIO port B bit 4
	PB5	120	I/O	GPIO port B bit 5
GPIO, Port C	PC0	100	I/O	GPIO port C bit 0
	PC1	99	I/O	GPIO port C bit 1
	PC2	98	I/O	GPIO port C bit 2
	PC3	97	I/O	GPIO port C bit 3
	PC4	25	I/O	GPIO port C bit 4
	PC5	24	I/O	GPIO port C bit 5
	PC6	23	I/O	GPIO port C bit 6
	PC7	22	I/O	GPIO port C bit 7

表 4-3. Signal Descriptions (continued)

FUNCTION	SIGNAL NAME	PIN NO.	PIN TYPE	DESCRIPTION
GPIO, Port D	PD0	1	I/O	GPIO port D bit 0
	PD1	2	I/O	GPIO port D bit 1
	PD2	3	I/O	GPIO port D bit 2
	PD3	4	I/O	GPIO port D bit 3
	PD4	125	I/O	GPIO port D bit 4
	PD5	126	I/O	GPIO port D bit 5
	PD6	127	I/O	GPIO port D bit 6
	PD7	128	I/O	GPIO port D bit 7
GPIO, Port E	PE0	15	I/O	GPIO port E bit 0
	PE1	14	I/O	GPIO port E bit 1
	PE2	13	I/O	GPIO port E bit 2
	PE3	12	I/O	GPIO port E bit 3
	PE4	123	I/O	GPIO port E bit 4
	PE5	124	I/O	GPIO port E bit 5
GPIO, Port F	PF0	42	I/O	GPIO port F bit 0
	PF1	43	I/O	GPIO port F bit 1
	PF2	44	I/O	GPIO port F bit 2
	PF3	45	I/O	GPIO port F bit 3
	PF4	46	I/O	GPIO port F bit 4
GPIO, Port G	PG0	49	I/O	GPIO port G bit 0
	PG1	50	I/O	GPIO port G bit 1
GPIO, Port H	PH0	29	I/O	GPIO port H bit 0
	PH1	30	I/O	GPIO port H bit 1
	PH2	31	I/O	GPIO port H bit 2
	PH3	32	I/O	GPIO port H bit 3
GPIO, Port J	PJ0	116	I/O	GPIO port J bit 0
	PJ1	117	I/O	GPIO port J bit 1
GPIO, Port K	PK0	18	I/O	GPIO port K bit 0
	PK1	19	I/O	GPIO port K bit 1
	PK2	20	I/O	GPIO port K bit 2
	PK3	21	I/O	GPIO port K bit 3
	PK4	63	I/O	GPIO port K bit 4
	PK5	62	I/O	GPIO port K bit 5
	PK6	61	I/O	GPIO port K bit 6
	PK7	60	I/O	GPIO port K bit 7
GPIO, Port L	PL0	81	I/O	GPIO port L bit 0
	PL1	82	I/O	GPIO port L bit 1
	PL2	83	I/O	GPIO port L bit 2
	PL3	84	I/O	GPIO port L bit 3
	PL4	85	I/O	GPIO port L bit 4
	PL5	86	I/O	GPIO port L bit 5
	PL6	94	I/O	GPIO port L bit 6
	PL7	93	I/O	GPIO port L bit 7

表 4-3. Signal Descriptions (continued)

FUNCTION	SIGNAL NAME	PIN NO.	PIN TYPE	DESCRIPTION
GPIO, Port M	PM0	78	I/O	GPIO port M bit 0
	PM1	77	I/O	GPIO port M bit 1
	PM2	76	I/O	GPIO port M bit 2
	PM3	75	I/O	GPIO port M bit 3
	PM4	74	I/O	GPIO port M bit 4
	PM5	73	I/O	GPIO port M bit 5
	PM6	72	I/O	GPIO port M bit 6
	PM7	71	I/O	GPIO port M bit 7
GPIO, Port N	PN0	107	I/O	GPIO port N bit 0
	PN1	108	I/O	GPIO port N bit 1
	PN2	109	I/O	GPIO port N bit 2
	PN3	110	I/O	GPIO port N bit 3
	PN4	111	I/O	GPIO port N bit 4
	PN5	112	I/O	GPIO port N bit 5
GPIO, Port P	PP0	118	I/O	GPIO port P bit 0
	PP1	119	I/O	GPIO port P bit 1
	PP2	103	I/O	GPIO port P bit 2
	PP3	104	I/O	GPIO port P bit 3
	PP4	105	I/O	GPIO port P bit 4
	PP5	106	I/O	GPIO port P bit 5
GPIO, Port Q	PQ0	5	I/O	GPIO port Q bit 0
	PQ1	6	I/O	GPIO port Q bit 1
	PQ2	11	I/O	GPIO port Q bit 2
	PQ3	27	I/O	GPIO port Q bit 3
	PQ4	102	I/O	GPIO port Q bit 4
Hibernate	HIB	65	O	An output that indicates the processor is in Hibernate mode
	RTCCLK	24 60 104	O	Buffered version of the Hibernation module's 32.768-kHz clock. This signal is not output when the part is in Hibernate mode and before being configured after power-on reset.
	TMPR0	71	I/O	Tamper signal 0
	TMPR1	72	I/O	Tamper signal 1
	TMPR2	73	I/O	Tamper signal 2
	TMPR3	74	I/O	Tamper signal 3
	VBAT	68	-	Power source for the Hibernation module. It is normally connected to the positive terminal of a battery and serves as the battery backup and Hibernation module power-source supply.
	$\overline{\text{WAKE}}$	64	I	An external input that brings the processor out of Hibernate mode when asserted
	XOSC0	66	I	Hibernation module oscillator crystal input or an external clock reference input. This is either a crystal or a 32.768-kHz oscillator for the Hibernation module RTC.
XOSC1	67	O	Hibernation module oscillator crystal output. Leave unconnected when using a single-ended clock source.	

表 4-3. Signal Descriptions (continued)

FUNCTION	SIGNAL NAME	PIN NO.	PIN TYPE	DESCRIPTION
I ² C	I2C0SCL	91	I/O	I ² C module 0 clock. This signal has an active pullup. The corresponding port pin should not be configured as open drain.
	I2C0SDA	92	I/O	I ² C module 0 data
	I2C1SCL	49	I/O	I ² C module 1 clock. This signal has an active pullup. The corresponding port pin should not be configured as open drain.
	I2C1SDA	50	I/O	I ² C module 1 data
	I2C2SCL	82 106 112	I/O	I ² C module 2 clock. This signal has an active pullup. The corresponding port pin should not be configured as open drain.
	I2C2SDA	81 111	I/O	I ² C module 2 data
	I2C3SCL	63	I/O	I ² C module 3 clock. This signal has an active pullup. The corresponding port pin should not be configured as open drain.
	I2C3SDA	62	I/O	I ² C module 3 data
	I2C4SCL	61	I/O	I ² C module 4 clock. This signal has an active pullup. The corresponding port pin should not be configured as open drain.
	I2C4SDA	60	I/O	I ² C module 4 data
	I2C5SCL	95 121	I/O	I ² C module 5 clock. This signal has an active pullup. The corresponding port pin should not be configured as open drain.
	I2C5SDA	96 120	I/O	I ² C module 5 data
	I2C6SCL	40	I/O	I ² C module 6 clock. This signal has an active pullup. The corresponding port pin should not be configured as open drain.
	I2C6SDA	41	I/O	I ² C module 6 data
	I2C7SCL	1 37	I/O	I ² C module 7 clock. This signal has an active pullup. The corresponding port pin should not be configured as open drain.
	I2C7SDA	2 38	I/O	I ² C module 7 data
	I2C8SCL	3 35	I/O	I ² C module 8 clock. This signal has an active pullup. The corresponding port pin should not be configured as open drain.
	I2C8SDA	4 36	I/O	I ² C module 8 data
	I2C9SCL	33	I/O	I ² C module 9 clock. This signal has an active pullup. The corresponding port pin should not be configured as open drain.
I2C9SDA	34	I/O	I ² C module 9 data	
JTAG, SWD, SWO	TCK/SWCLK	100	I	JTAG/SWD clock
	TDI	98	I	JTAG TDI
	TDO/SWO	97	O	JTAG TDO and SWO
	TMS/SWDIO	99	I	JTAG TMS and SWDIO

表 4-3. Signal Descriptions (continued)

FUNCTION	SIGNAL NAME	PIN NO.	PIN TYPE	DESCRIPTION
PWM	M0FAULT0	46	I	Motion Control module 0 PWM fault 0
	M0FAULT1	61	I	Motion Control module 0 PWM fault 1
	M0FAULT2	60	I	Motion Control module 0 PWM fault 2
	M0FAULT3	81	I	Motion Control module 0 PWM fault 3
	M0PWM0	42	O	Motion Control module 0 PWM 0. This signal is controlled by module 0 PWM generator 0.
	M0PWM1	43	O	Motion Control module 0 PWM 1. This signal is controlled by module 0 PWM generator 0.
	M0PWM2	44	O	Motion Control module 0 PWM 2. This signal is controlled by module 0 PWM generator 1.
	M0PWM3	45	O	Motion Control module 0 PWM 3. This signal is controlled by module 0 PWM generator 1.
	M0PWM4	49	O	Motion Control module 0 PWM 4. This signal is controlled by module 0 PWM generator 2.
	M0PWM5	50	O	Motion Control module 0 PWM 5. This signal is controlled by module 0 PWM generator 2.
	M0PWM6	63	O	Motion Control module 0 PWM 6. This signal is controlled by module 0 PWM generator 3.
	M0PWM7	62	O	Motion Control module 0 PWM 7. This signal is controlled by module 0 PWM generator 3.
Power	GND	17 48 55 58 80 114	-	Ground reference for logic and I/O pins
	GNDA	10	-	The ground reference for the analog circuits (ADC, Analog Comparators, etc.). These are separated from GND to minimize the electrical noise contained on VDD from affecting the analog functions
	VDD	7 16 26 28 39 47 51 52 69 79 90 101 113 122	-	Positive supply for I/O and some logic
	VDDA	8	-	The positive supply for the analog circuits (for example, ADC and Analog Comparators). These are separated from VDD to minimize the electrical noise contained on VDD from affecting the analog functions. VDDA pins must be supplied with a voltage that meets the specification in, regardless of system implementation
	VDDC	87 115	-	Positive supply for most of the logic function, including the processor core and most peripherals. The voltage on this pin is 1.2 V and is supplied by the on-chip LDO. The VDDC pins should only be connected to each other and an external capacitor as specified in the LDO electrical specifications.
QE1	IDX0	84	I	QE1 module 0 index
	PhA0	82	I	QE1 module 0 phase A
	PhB0	83	I	QE1 module 0 phase B

表 4-3. Signal Descriptions (continued)

FUNCTION	SIGNAL NAME	PIN NO.	PIN TYPE	DESCRIPTION	
SSI	SSI0Clk	35	I/O	SSI module 0 clock	
	SSI0Fss	36	I/O	SSI module 0 frame signal	
	SSI0XDAT0	37	I/O	SSI module 0 bidirectional data pin 0 (SSI0TX in Legacy SSI mode)	
	SSI0XDAT1	38	I/O	SSI module 0 bidirectional data pin 1 (SSI0RX in Legacy SSI mode)	
	SSI0XDAT2	40	I/O	SSI module 0 bidirectional data pin 2	
	SSI0XDAT3	41	I/O	SSI module 0 bidirectional data pin 3	
	SSI1Clk	120	I/O	SSI module 1 clock	
	SSI1Fss	121	I/O	SSI module 1 frame signal	
	SSI1XDAT0	123	I/O	SSI module 1 bidirectional data pin 0 (SSI1TX in Legacy SSI mode)	
	SSI1XDAT1	124	I/O	SSI module 1 bidirectional data pin 1 (SSI1RX in Legacy SSI mode)	
	SSI1XDAT2	125	I/O	SSI module 1 bidirectional data pin 2	
	SSI1XDAT3	126	I/O	SSI module 1 bidirectional data pin 3	
	SSI2Clk	4	I/O	SSI module 2 clock	
	SSI2Fss	3	I/O	SSI module 2 frame signal	
	SSI2XDAT0	2	I/O	SSI module 2 bidirectional data pin 0 (SSI2TX in Legacy SSI mode)	
	SSI2XDAT1	1	I/O	SSI module 2 bidirectional data pin 1 (SSI2RX in Legacy SSI mode)	
	SSI2XDAT2	128	I/O	SSI module 2 bidirectional data pin 2	
	SSI2XDAT3	127	I/O	SSI module 2 bidirectional data pin 3	
	System Control and Clocks	SSI3Clk	5 45	I/O	SSI module 3 clock
		SSI3Fss	6 44	I/O	SSI module 3 frame signal
SSI3XDAT0		11 43	I/O	SSI module 3 bidirectional data pin 0 (SSI3TX in Legacy SSI mode)	
SSI3XDAT1		27 42	I/O	SSI module 3 bidirectional data pin 1 (SSI3RX in Legacy SSI mode)	
SSI3XDAT2		46 118	I/O	SSI module 3 bidirectional data pin 2	
SSI3XDAT3		119	I/O	SSI module 3 bidirectional data pin 3	
DIVSCLK		102	O	An optionally divided reference clock output based on a selected clock source. This signal is not synchronized to the system clock.	
NMI		128	I	Nonmaskable interrupt	
OSC0	88	I	Main oscillator crystal input or an external clock reference input		
OSC1	89	O	Main oscillator crystal output. Leave unconnected when using a single-ended clock source.		
RST	70	I	System reset input		

表 4-3. Signal Descriptions (continued)

FUNCTION	SIGNAL NAME	PIN NO.	PIN TYPE	DESCRIPTION
UART Module 0	U0CTS	30 74 121	I	UART module 0 Clear To Send modem flow control input signal
	U0DCD	31 73 104	I	UART module 0 Data Carrier Detect modem status input signal
	U0DSR	32 72 105	I	UART module 0 Data Set Ready modem output control line
	U0DTR	103	O	UART module 0 Data Terminal Ready modem status input signal
	U0RI	60 71	I	UART module 0 Ring Indicator modem status input signal
	U0RTS	29 120	O	UART module 0 Request to Send modem flow control output signal
	U0Rx	33	I	UART module 0 receive
	U0Tx	34	O	UART module 0 transmit
UART Module 1	U1CTS	104 108	I	UART module 1 Clear To Send modem flow control input signal
	U1DCD	13 109	I	UART module 1 Data Carrier Detect modem status input signal
	U1DSR	14 110	I	UART module 1 Data Set Ready modem output control line
	U1DTR	12 111	O	UART module 1 Data Terminal Ready modem status input signal
	U1RI	112 123	I	UART module 1 Ring Indicator modem status input signal
	U1RTS	15 107	O	UART module 1 Request to Send modem flow control output line
	U1Rx	95 102	I	UART module 1 receive.
	U1Tx	96	O	UART module 1 transmit
UART Module 2	U2CTS	110 128	I	UART module 2 Clear To Send modem flow control input signal
	U2RTS	109 127	O	UART module 2 Request to Send modem flow control output line
	U2Rx	40 125	I	UART module 2 receive
	U2Tx	41 126	O	UART module 2 transmit
UART Module 3	U3CTS	106 112	I	UART module 3 Clear To Send modem flow control input signal
	U3RTS	105 111	O	UART module 3 Request to Send modem flow control output line
	U3Rx	37 116	I	UART module 3 receive
	U3Tx	38 117	O	UART module 3 transmit
UART Module 4	U4CTS	21	I	UART module 4 Clear To Send modem flow control input signal
	U4RTS	20	O	UART module 4 Request to Send modem flow control output line
	U4Rx	18 35	I	UART module 4 receive
	U4Tx	19 36	O	UART module 4 transmit

表 4-3. Signal Descriptions (continued)

FUNCTION	SIGNAL NAME	PIN NO.	PIN TYPE	DESCRIPTION
UART Module 5	U5Rx	23	I	UART module 5 receive
	U5Tx	22	O	UART module 5 transmit
UART Module 6	U6Rx	118	I	UART module 6 receive
	U6Tx	119	O	UART module 6 transmit
UART Module 7	U7Rx	25	I	UART module 7 receive
	U7Tx	24	O	UART module 7 transmit
USB	USB0CLK	92	O	60-MHz clock to the external PHY
	USB0D0	81	I/O	USB data 0
	USB0D1	82	I/O	USB data 1
	USB0D2	83	I/O	USB data 2
	USB0D3	84	I/O	USB data 3
	USB0D4	85	I/O	USB data 4
	USB0D5	86	I/O	USB data 5
	USB0D6	106	I/O	USB data 6
	USB0D7	105	I/O	USB data 7
	USB0DIR	104	O	Indicates that the external PHY is able to accept data from the USB controller
	USB0DM	93	I/O	Bidirectional differential data pin (D– per USB specification) for USB0
	USB0DP	94	I/O	Bidirectional differential data pin (D+ per USB specification) for USB0
	USB0EPEN	40 41 127	O	Optionally used in Host mode to control an external power source to supply power to the USB bus
	USB0ID	95	I	This signal senses the state of the USB ID signal. The USB PHY enables an integrated pull-up, and an external element (USB connector) indicates the initial state of the USB controller (pulled down is the A side of the cable and pulled up is the B side).
	USB0NXT	103	O	Asserted by the external PHY to throttle all data types
	USB0PFLT	41 128	I	Optionally used in Host mode by an external power source to indicate an error state by that power source
USB0STP	91	O	Asserted by the USB controller to signal the end of a USB transmit packet or register write operation	
USB0VBUS	96	I/O	This signal is used during the session request protocol. This signal allows the USB PHY to both sense the voltage level of VBUS, and pull up VBUS momentarily during VBUS pulsing.	

4.4 GPIO Pin Multiplexing

表 4-4 lists the GPIO pins and their analog and digital alternate functions. The AINx analog signals go through an isolation circuit before reaching their circuitry. These signals are configured by clearing the corresponding DEN bit in the GPIO Digital Enable (GPIODEN) register and setting the corresponding AMSEL bit in the GPIO Analog Mode Select (GPIOAMSEL) register. Other analog signals are 3.3-V tolerant and are connected directly to their circuitry (C0-, C0+, C1-, C1+, C2-, C2+, USB0VBUS, USB0ID). These signals are configured by clearing the DEN bit in the GPIODEN register. The digital signals are enabled by setting the appropriate bit in the GPIO Alternate Function Select (GPIOAFSEL) and GPIODEN registers and configuring the PMCx bit field in the GPIO Port Control (GPIOPCTL) register to the numeric encoding shown in 表 4-4.

表 4-4. GPIO Pins and Alternate Functions

I/O	PIN	ANALOG OR SPECIAL FUNCTION ⁽¹⁾	DIGITAL FUNCTION (GPIOPCTL PMCx BIT FIELD ENCODING)											
			1	2	3	4	5	6	7	8	11	13	14	15
PA0	33	–	U0Rx	I2C9SCL	T0CCP0	–	–	–	CAN0Rx	–	–	–	–	–
PA1	34	–	U0Tx	I2C9SDA	T0CCP1	–	–	–	CAN0Tx	–	–	–	–	–
PA2	35	–	U4Rx	I2C8SCL	T1CCP0	–	–	–	–	–	–	–	–	SSI0Clk
PA3	36	–	U4Tx	I2C8SDA	T1CCP1	–	–	–	–	–	–	–	–	SSI0Fss
PA4	37	–	U3Rx	I2C7SCL	T2CCP0	–	–	–	–	–	–	–	–	SSI0XDAT0
PA5	38	–	U3Tx	I2C7SDA	T2CCP1	–	–	–	–	–	–	–	–	SSI0XDAT1
PA6	40	–	U2Rx	I2C6SCL	T3CCP0	–	USB0EPEN	–	–	–	–	SSI0XDAT2	–	EPI0S8
PA7	41	–	U2Tx	I2C6SDA	T3CCP1	–	USB0PFLT	–	–	–	USB0EPEN	SSI0XDAT3	–	EPI0S9
PB0	95	USB0ID	U1Rx	I2C5SCL	T4CCP0	–	–	–	CAN1Rx	–	–	–	–	–
PB1	96	USB0VBUS	U1Tx	I2C5SDA	T4CCP1	–	–	–	CAN1Tx	–	–	–	–	–
PB2	91	–	–	I2C0SCL	T5CCP0	–	–	–	–	–	–	–	USB0STP	EPI0S27
PB3	92	–	–	I2C0SDA	T5CCP1	–	–	–	–	–	–	–	USB0CLK	EPI0S28
PB4	121	AIN10	U0CTS	I2C5SCL	–	–	–	–	–	–	–	–	–	SSI1Fss
PB5	120	AIN11	U0RTS	I2C5SDA	–	–	–	–	–	–	–	–	–	SSI1Clk
PC0	100	–	TCK SWCLK	–	–	–	–	–	–	–	–	–	–	–
PC1	99	–	TMS SWDIO	–	–	–	–	–	–	–	–	–	–	–
PC2	98	–	TDI	–	–	–	–	–	–	–	–	–	–	–
PC3	97	–	TDO SWO	–	–	–	–	–	–	–	–	–	–	–
PC4	25	C1-	U7Rx	–	–	–	–	–	–	–	–	–	–	EPI0S7
PC5	24	C1+	U7Tx	–	–	–	–	–	RTCCLK	–	–	–	–	EPI0S6
PC6	23	C0+	U5Rx	–	–	–	–	–	–	–	–	–	–	EPI0S5
PC7	22	C0-	U5Tx	–	–	–	–	–	–	–	–	–	–	EPI0S4
PD0	1	AIN15	–	I2C7SCL	T0CCP0	–	C0o	–	–	–	–	–	–	SSI2XDAT1
PD1	2	AIN14	–	I2C7SDA	T0CCP1	–	C1o	–	–	–	–	–	–	SSI2XDAT0

(1) The TMPRn signals are digital signals enabled and configured by the Hibernation module. All other signals listed in this column are analog signals.

表 4-4. GPIO Pins and Alternate Functions (continued)

I/O	PIN	ANALOG OR SPECIAL FUNCTION ⁽¹⁾	DIGITAL FUNCTION (GPIO PCTL PMCx BIT FIELD ENCODING)												
			1	2	3	4	5	6	7	8	11	13	14	15	
PD2	3	AIN13	–	I2C8SCL	T1CCP0	–	C2o	–	–	–	–	–	–	–	SSI2Fss
PD3	4	AIN12	–	I2C8SDA	T1CCP1	–	–	–	–	–	–	–	–	–	SSI2Cik
PD4	125	AIN7	U2Rx	–	T3CCP0	–	–	–	–	–	–	–	–	–	SSI1XDAT2
PD5	126	AIN6	U2Tx	–	T3CCP1	–	–	–	–	–	–	–	–	–	SSI1XDAT3
PD6	127	AIN5	U2RTS	–	T4CCP0	–	USB0EPEN	–	–	–	–	–	–	–	SSI2XDAT3
PD7	128	AIN4	U2CTS	–	T4CCP1	–	USB0PFLT	–	–	NMI	–	–	–	–	SSI2XDAT2
PE0	15	AIN3	U1RTS	–	–	–	–	–	–	–	–	–	–	–	–
PE1	14	AIN2	U1DSR	–	–	–	–	–	–	–	–	–	–	–	–
PE2	13	AIN1	U1DCD	–	–	–	–	–	–	–	–	–	–	–	–
PE3	12	AIN0	U1DTR	–	–	–	–	–	–	–	–	–	–	–	–
PE4	123	AIN9	U1RI	–	–	–	–	–	–	–	–	–	–	–	SSI1XDAT0
PE5	124	AIN8	–	–	–	–	–	–	–	–	–	–	–	–	SSI1XDAT1
PF0	42	–	–	–	–	–	EN0LED0	M0PWM0	–	–	–	–	–	SSI3XDAT1	TRD2
PF1	43	–	–	–	–	–	EN0LED2	M0PWM1	–	–	–	–	–	SSI3XDAT0	TRD1
PF2	44	–	–	–	–	–	–	M0PWM2	–	–	–	–	–	SSI3Fss	TRD0
PF3	45	–	–	–	–	–	–	M0PWM3	–	–	–	–	–	SSI3Cik	TRCLK
PF4	46	–	–	–	–	–	EN0LED1	M0FAULT0	–	–	–	–	–	SSI3XDAT2	TRD3
PG0	49	–	–	I2C1SCL	–	–	EN0PPS	M0PWM4	–	–	–	–	–	–	EPI0S11
PG1	50	–	–	I2C1SDA	–	–	–	M0PWM5	–	–	–	–	–	–	EPI0S10
PH0	29	–	U0RTS	–	–	–	–	–	–	–	–	–	–	–	EPI0S0
PH1	30	–	U0CTS	–	–	–	–	–	–	–	–	–	–	–	EPI0S1
PH2	31	–	U0DCD	–	–	–	–	–	–	–	–	–	–	–	EPI0S2
PH3	32	–	U0DSR	–	–	–	–	–	–	–	–	–	–	–	EPI0S3
PJ0	116	–	U3Rx	–	–	–	EN0PPS	–	–	–	–	–	–	–	–
PJ1	117	–	U3Tx	–	–	–	–	–	–	–	–	–	–	–	–
PK0	18	AIN16	U4Rx	–	–	–	–	–	–	–	–	–	–	–	EPI0S0
PK1	19	AIN17	U4Tx	–	–	–	–	–	–	–	–	–	–	–	EPI0S1
PK2	20	AIN18	U4RTS	–	–	–	–	–	–	–	–	–	–	–	EPI0S2
PK3	21	AIN19	U4CTS	–	–	–	–	–	–	–	–	–	–	–	EPI0S3
PK4	63	–	–	I2C3SCL	–	–	EN0LED0	M0PWM6	–	–	–	–	–	–	EPI0S32
PK5	62	–	–	I2C3SDA	–	–	EN0LED2	M0PWM7	–	–	–	–	–	–	EPI0S31
PK6	61	–	–	I2C4SCL	–	–	EN0LED1	M0FAULT1	–	–	–	–	–	–	EPI0S25
PK7	60	–	U0RI	I2C4SDA	–	–	RTCCLK	M0FAULT2	–	–	–	–	–	–	EPI0S24
PL0	81	–	–	I2C2SDA	–	–	–	M0FAULT3	–	–	–	–	–	USB0D0	EPI0S16

表 4-4. GPIO Pins and Alternate Functions (continued)

I/O	PIN	ANALOG OR SPECIAL FUNCTION (1)	DIGITAL FUNCTION (GPIO PCTL PMCx BIT FIELD ENCODING)												
			1	2	3	4	5	6	7	8	11	13	14	15	
PL1	82	–	–	I2C2SCL	–	–	–	–	PhA0	–	–	–	–	USB0D1	EPI0S17
PL2	83	–	–	–	–	–	–	C0o	PhB0	–	–	–	–	USB0D2	EPI0S18
PL3	84	–	–	–	–	–	–	C1o	IDX0	–	–	–	–	USB0D3	EPI0S19
PL4	85	–	–	–	T0CCP0	–	–	–	–	–	–	–	–	USB0D4	EPI0S26
PL5	86	–	–	–	T0CCP1	–	–	–	–	–	–	–	–	USB0D5	EPI0S33
PL6	94	USB0DP	–	–	T1CCP0	–	–	–	–	–	–	–	–	–	–
PL7	93	USB0DM	–	–	T1CCP1	–	–	–	–	–	–	–	–	–	–
PM0	78	–	–	–	T2CCP0	–	–	–	–	–	–	–	–	–	EPI0S15
PM1	77	–	–	–	T2CCP1	–	–	–	–	–	–	–	–	–	EPI0S14
PM2	76	–	–	–	T3CCP0	–	–	–	–	–	–	–	–	–	EPI0S13
PM3	75	–	–	–	T3CCP1	–	–	–	–	–	–	–	–	–	EPI0S12
PM4	74	TMPR3	U0CTS	–	T4CCP0	–	–	–	–	–	–	–	–	–	–
PM5	73	TMPR2	U0DCD	–	T4CCP1	–	–	–	–	–	–	–	–	–	–
PM6	72	TMPR1	U0DSR	–	T5CCP0	–	–	–	–	–	–	–	–	–	–
PM7	71	TMPR0	U0RI	–	T5CCP1	–	–	–	–	–	–	–	–	–	–
PN0	107	–	U1RTS	–	–	–	–	–	–	–	–	–	–	–	–
PN1	108	–	U1CTS	–	–	–	–	–	–	–	–	–	–	–	–
PN2	109	–	U1DCD	U2RTS	–	–	–	–	–	–	–	–	–	–	EPI0S29
PN3	110	–	U1DSR	U2CTS	–	–	–	–	–	–	–	–	–	–	EPI0S30
PN4	111	–	U1DTR	U3RTS	I2C2SDA	–	–	–	–	–	–	–	–	–	EPI0S34
PN5	112	–	U1RI	U3CTS	I2C2SCL	–	–	–	–	–	–	–	–	–	EPI0S35
PP0	118	C2+	U6Rx	–	–	–	–	–	–	–	–	–	–	–	SSI3XDAT2
PP1	119	C2-	U6Tx	–	–	–	–	–	–	–	–	–	–	–	SSI3XDAT3
PP2	103	–	U0DTR	–	–	–	–	–	–	–	–	–	–	USB0NXT	EPI0S29
PP3	104	–	U1CTS	U0DCD	–	–	–	–	–	RTCCLK	–	–	–	USB0DIR	EPI0S30
PP4	105	–	U3RTS	U0DSR	–	–	–	–	–	–	–	–	–	USB0D7	–
PP5	106	–	U3CTS	I2C2SCL	–	–	–	–	–	–	–	–	–	USB0D6	–
PQ0	5	–	–	–	–	–	–	–	–	–	–	–	–	SSI3Cik	EPI0S20
PQ1	6	–	–	–	–	–	–	–	–	–	–	–	–	SSI3Fss	EPI0S21
PQ2	11	–	–	–	–	–	–	–	–	–	–	–	–	SSI3XDAT0	EPI0S22
PQ3	27	–	–	–	–	–	–	–	–	–	–	–	–	SSI3XDAT1	EPI0S23
PQ4	102	–	U1Rx	–	–	–	–	–	–	DIVSCLK	–	–	–	–	–

4.5 Buffer Type

表 4-5 describes the buffer types that are referenced in 节 4.2.

表 4-5. Buffer Type

BUFFER TYPE (STANDARD)	NOMINAL VOLTAGE	HYSTERESIS	PU OR PD	NOMINAL PU OR PD STRENGTH (μ A)	OUTPUT DRIVE STRENGTH (mA)	OTHER CHARACTERISTICS
Analog ⁽¹⁾	3.3 V	N	N/A	N/A	N/A	See analog modules in 节 5 for details.
LVC MOS	3.3 V	Y ⁽²⁾	Programmable	See Input/Output Pin Characteristics	See Typical Characteristics.	
Power (VDD) ⁽³⁾	3.3 V	N	N/A	N/A	N/A	
Power (VDDA) ⁽³⁾	3.3 V	N	N/A	N/A	N/A	
Power (GND and GND A) ⁽³⁾	0 V	N	N/A	N/A	N/A	

(1) This is a switch, not a buffer.

(2) Only for input pins

(3) This is supply input, not a buffer.

4.6 Connections for Unused Pins

表 4-6 lists the recommended connections for unused pins.

表 4-6 lists two options: an acceptable practice and a preferred practice for reduced power consumption and improved EMC characteristics. If a module is not used in a system, and its inputs are grounded, it is important that the clock to the module is never enabled by setting the corresponding bit in the RCGCx register.

表 4-6. Connections for Unused Pins

FUNCTION	SIGNAL NAME	PIN NUMBER	ACCEPTABLE PRACTICE	PREFERRED PRACTICE
ADC	VREFA+	9	VDDA	VDDA
Ethernet	ENORXIN	53	NC	NC
	ENORXIP	54	NC	NC
	ENOTXON	56	NC	NC
	ENOTXOP	57	NC	NC
	RBIAS	59	Connect to ground through 4.87-k Ω resistor.	Connect to ground through 4.87-k Ω resistor.
GPIO	PA1 (U0Tx)	34	NC	GND ⁽¹⁾
	PA4 (SSI0XDAT0)	37	NC	GND ⁽²⁾
	All unused GPIOs		NC	GND
Hibernate	$\overline{\text{HIB}}$	65	NC	NC
	VBAT	68	NC	VDD
	$\overline{\text{WAKE}}$	64	NC	GND
	XOSC0	66	NC	GND
	XOSC1	67	NC	NC

(1) PA1 (U0Tx) may be enabled as an output by the ROM bootloader if no code is present in the flash and PA0 (U0Rx) receives a valid boot signature. Ensure that this condition will not occur if PA1 is to be connected directly to GND.

(2) PA4 (SSI0XDAT0) may be enabled as an output by the ROM bootloader if no code is present in the flash and the SSI0x (PA2, PA3, PA5) receives a valid boot signature. Ensure that this condition will not occur if PA4 is to be connected directly to GND.

表 4-6. Connections for Unused Pins (continued)

FUNCTION	SIGNAL NAME	PIN NUMBER	ACCEPTABLE PRACTICE	PREFERRED PRACTICE
System Control	OSC0	88	NC	GND
	OSC1	89	NC	NC
	$\overline{\text{RST}}$	70	VDD	Pull up to VDD with 0 to 100-k Ω resistor. ⁽³⁾
USB	USB0DM / PL7	93	NC	Pull down to GND with 1-k Ω resistor. ⁽⁴⁾
	USB0DP / PL6	94	NC	Pull down to GND with 1-k Ω resistor. ⁽⁴⁾

(3) For details, see the *System Control* chapter of the [SimpleLink™ MSP432E4 Microcontrollers Technical Reference Manual](#)

(4) The ROM bootloader may configure these pins as USB pins if no code is present in the flash. Therefore, they should not be connected directly to ground.

5 Specifications

5.1 Absolute Maximum Ratings

over operating free-air temperature range (unless otherwise noted) ⁽¹⁾ ⁽²⁾

		MIN	MAX	UNIT
V _{DD}	V _{DD} supply voltage	0	4	V
V _{DDA}	V _{DDA} supply voltage	0	4	V
V _{BAT}	V _{BAT} battery supply voltage	0	4	V
V _{BATRMP}	V _{BAT} battery supply voltage ramp time	0	0.7	V/μs
V _{IN_GPIO}	Input voltage ⁽³⁾	-0.3	4	V
I _{GPIO MAX}	Maximum current per output pin		64	mA
T _S	Unpowered storage temperature range	-65	150	°C
T _{JMAX}	Maximum junction temperature		125	°C

- (1) Stresses beyond those listed under *Absolute Maximum Ratings* may cause permanent damage to the device. These are stress ratings only, and functional operation of the device at these or any other conditions beyond those indicated under *Recommended Operating Conditions* is not implied. Exposure to absolute-maximum-rated conditions for extended periods may affect device reliability.
- (2) Voltages are measured with respect to GND.
- (3) Applies to static and dynamic signals including overshoot.

5.2 ESD Ratings

over operating free-air temperature range (unless otherwise noted)

		VALUE	UNIT
V _(ESD)	Electrostatic discharge	Human-body model (HBM), per ANSI/ESDA/JEDEC JS-001 ⁽¹⁾ ⁽²⁾	±2000
		Charged-device model (CDM), per JEDEC specification JESD22-C101 ⁽³⁾	±500

- (1) JEDEC document JEP155 states that 500-V HBM allows safe manufacturing with a standard ESD control process. Pins listed as ±2000 V may actually have higher performance.
- (2) All pins are HBM compliant to ±2000 V for all combinations as per JESD22-A114F, except for the following stress combinations:
- The Ethernet EN0RXIN, EN0TXON, EN0RXIP, and EN0TXOP pins to each other.
 - The GPIO pins PM4, PM5, PM6, and PM7 to other pins.
- These exceptions are compliant to 500 V and do not require any special handling beyond typical ESD control procedures during assembly operations per JEDEC publication JEP155. These pins do meet the 500-V CDM specification.
- (3) JEDEC document JEP157 states that 250-V CDM allows safe manufacturing with a standard ESD control process. Pins listed as ±500 V may actually have higher performance.

5.3 Recommended Operating Conditions

over operating free-air temperature range (unless otherwise noted)

		MIN	MAX	UNIT	
T _A	Ambient operating temperature range	Extended temperature	-40	105	°C
T _J	Junction operating temperature range	Extended temperature	-40	125	°C

5.4 Recommended DC Operating Conditions

over operating free-air temperature (unless otherwise noted)

		MIN	NOM	MAX	UNIT
V _{DD}	V _{DD} supply voltage	2.97	3.3	3.63	V
V _{DDA}	V _{DDA} supply voltage ⁽¹⁾	2.97	3.3	3.63	V
V _{DDC}	V _{DDC} supply voltage, run mode	1.14	1.2	1.32	V
V _{DDCDS}	V _{DDC} supply voltage, deep-sleep mode	0.85		0.95	V

- (1) To ensure proper operation, power on V_{DDA} before V_{DD} if sourced from different supplies, or connect V_{DDA} to the same supply as V_{DD}. No restriction exists for powering off.

5.5 Recommended GPIO Operating Characteristics

The following sections describe the recommended GPIO operating characteristics for the device.

Two types of pads are provided on the device:

- Fast GPIO pads: These pads provide variable, programmable drive strength and optimized voltage output levels.
- Slow GPIO pads: These pads provide 2-mA drive strength and are designed to be sensitive to voltage inputs. The PJ1 GPIOs port pins are slow GPIO pads. All other GPIOs have a fast GPIO pad type.

注

Port pins PL6 and PL7 operate as fast GPIO pads, but have 4-mA drive capability only. GPIO register controls for drive strength, slew rate and open drain have no effect on these pins. The registers which have no effect are as follows: GPIODR2R, GPIODR4R, GPIODR8R, GPIODR12R, GPIOCLR, and GPIOODR.

注

Port pins PM[7:4] operate as fast GPIO pads but support only 2-, 4-, 6-, and 8-mA drive capability. 10- and 12-mA drive are not supported. All standard GPIO register controls, except for the GPIODR12R register, apply to these port pins.

5.6 Recommended Fast GPIO Pad Operating Conditions

over operating free-air temperature range (unless otherwise noted)

		MIN	NOM	MAX	UNIT
V_{IH}	Fast GPIO high-level input voltage	$0.65 \times V_{DD}$		4	V
I_{IH}	Fast GPIO high-level input current			300	nA
V_{IL}	Fast GPIO low-level input voltage	0		$0.35 \times V_{DD}$	V
I_{IL}	Fast GPIO low-level input current ⁽¹⁾			-200	nA
V_{HYS}	Fast GPIO input hysteresis	0.49			V
V_{OH}	Fast GPIO high-level output voltage	2.4			V
V_{OL}	Fast GPIO low-level output voltage			0.40	V
I_{OH}	Fast GPIO high-level source current, $V_{OH} = 2.4$ V ⁽²⁾	2-mA drive		2.0	mA
		4-mA drive		4.0	
		8-mA drive		8.0	
		10-mA drive		10.0	
		12-mA drive		12.0	
I_{OL}	Fast GPIO low-level sink current, $V_{OL} = 0.4$ V ⁽²⁾	2-mA drive		2.0	mA
		4-mA drive		4.0	
		8-mA drive		8.0	
		10-mA drive		10.0	
		12-mA drive		12.0	
		12-mA drive overdriven to 18 mA		18.0	

(1) Output, pullup, and pulldown are disabled; only input is enabled.

(2) I_O specifications reflect the maximum current where the corresponding output voltage meets the V_{OH} or V_{OL} thresholds. I_O current can exceed these limits (subject to absolute maximum ratings).

5.7 Recommended Slow GPIO Pad Operating Conditions

over operating free-air temperature range (unless otherwise noted)

		MIN	NOM	MAX	UNIT
V_{IH}	Slow GPIO high-level input voltage	$0.65 \times V_{DD}$		4	V
I_{IH}	Slow GPIO high-level input current			4.1	nA

Recommended Slow GPIO Pad Operating Conditions (continued)

over operating free-air temperature range (unless otherwise noted)

		MIN	NOM	MAX	UNIT
V _{IL}	Slow GPIO low-level input voltage	0		0.35 × V _{DD}	V
I _{IL}	Slow GPIO low-level input current ⁽¹⁾			–1	nA
V _{HYS}	Slow GPIO input hysteresis	0.49			V
V _{OH}	Slow GPIO high-level output voltage	2.4			V
V _{OL}	Slow GPIO low-level output voltage			0.4	V
I _{OH}	Slow GPIO high-level source current, V _{OH} = 2.4 V, 2-mA drive	2.0			mA
I _{OL}	Slow GPIO low-level sink current, V _{OL} = 0.4 V ⁽²⁾ , 2-mA drive	2.0			mA

(1) Output, pullup, and pulldown are disabled; only input is enabled.

(2) I_O specifications reflect the maximum current where the corresponding output voltage meets the V_{OH} or V_{OL} thresholds. I_O current can exceed these limits (subject to absolute maximum ratings).

5.8 GPIO Current Restrictions

over operating free-air temperature range (unless otherwise noted) ⁽¹⁾

		MIN	NOM	MAX	UNIT
I _{MAXL}	Cumulative maximum GPIO current per side, left			112	mA
I _{MAXB}	Cumulative maximum GPIO current per side, bottom ⁽²⁾			97.6	mA
I _{MAXR}	Cumulative maximum GPIO current per side, right ⁽²⁾			112	mA
I _{MAXT}	Cumulative maximum GPIO current per side, top ⁽²⁾			80	mA

(1) Based on design simulations, not tested in production.

(2) Sum of sink and source current for GPIOs as listed in 表 5-1.

表 5-1. Maximum GPIO Package Side Assignments

SIDE	GPIOs
Left	PC[4-7], PD[0-3], PQ[0-3], PE[0-3], PK[0-3], PN[4-5], PH[0-3]
Bottom	PA[0-7], PF[0-4], PG[0-1], PK[4-7]
Right	PM[0-7], PL[0-7], PB[0-3]
Top	PC[0-3], PQ[4], PP[0-5], PN[0-5], PJ[0-1], PB[4-5], PE[4-5], PD[4-7]

5.9 I/O Reliability

For typical continuous drive applications, I/O pins configured in the range from 2 mA to 12 mA and operating at –40°C to 85°C meet the standard 10-year lifetime reliability. If a continuous current sink of 18 mA is required, then operation is limited to 0 to 75°C to meet the standard 10-year reliability.

At 105°C, I/O pins configured for continuous drive meet the standard 2.5-year lifetime reliability.

In typical switching applications (40% switch rate) operating at –40°C to 85°C, all I/O configurations except 2 mA meet the standard 10-year lifetime reliability with 50-pF loading. By limiting the capacitive loading to 20 pF for an I/O configured to 2 mA, the 10-year lifetime reliability can be met at –40°C to 85°C.

In typical switching applications (40% switch rate) operating at 105°C, all I/O configurations except 2 mA meet the standard 2.5-year lifetime reliability. By reducing the capacitive loading to 20 pF with a typical switching rate at 105°C, a 2-mA I/O configuration meets a 2.5-year lifetime reliability.

5.10 Current Consumption

over operating free-air temperature (unless otherwise noted) ⁽¹⁾

PARAMETER	TEST CONDITIONS	SYSTEM CLOCK		TYP				MAX		UNIT	
		FREQ	CLOCK SOURCE	-40°C	25°C	85°C	105°C	85°C	105°C ⁽²⁾		
I_{DD_RUN}	Run mode (flash loop)	$V_{DD} = 3.3\text{ V}$, $V_{DDA} = 3.3\text{ V}$, Peripherals = All on including MAC and PHY	120 MHz	MOSC with PLL	96.4	105.3	107.2	108.7	129.9	140.0	mA
			60 MHz	MOSC with PLL	67.4	76.6	78.6	79.9	100.3	112.5	
			16 MHz	PIOSC	11.9	24.4	25.5	26.7	45.0	56.4	
			1 MHz	PIOSC	5.75	10.9	12.1	13.3	31.3	42.6	
		$V_{DD} = 3.3\text{ V}$, $V_{DDA} = 3.3\text{ V}$, Peripherals = All on including MAC but not PHY	120 MHz	MOSC with PLL	69.9	77.8	79.6	80.8	98.8	108.4	
			60 MHz	MOSC with PLL	40.9	49.2	50.9	52.1	69.2	80.8	
			16 MHz	PIOSC	11.3	23.6	25.0	26.2	43.1	54.3	
			1 MHz	PIOSC	5.10	10.1	11.5	12.7	29.3	40.5	
		$V_{DD} = 3.3\text{ V}$, $V_{DDA} = 3.3\text{ V}$, Peripherals = All on except MAC and PHY	120 MHz	MOSC with PLL	68.1	76.0	77.6	78.6	96.6	106.0	
			60 MHz	MOSC with PLL	40.0	48.2	49.8	50.8	67.9	79.2	
			16 MHz	PIOSC	11.1	23.3	24.6	25.6	42.5	53.3	
			1 MHz	PIOSC	5.07	10.1	11.3	12.3	29.0	39.8	
	$V_{DD} = 3.3\text{ V}$, $V_{DDA} = 3.3\text{ V}$, Peripherals = All off	120 MHz	MOSC with PLL	35.2	39.1	40.4	41.5	55.8	65.3		
		60 MHz	MOSC with PLL	23.2	29.4	30.7	31.7	45.8	55.5		
		16 MHz	PIOSC	7.38	17.9	19.0	20.0	34.5	44.1		
		1 MHz	PIOSC	4.12	9.13	10.3	11.4	25.7	35.5		
	Run mode (SRAM loop)	$V_{DD} = 3.3\text{ V}$, $V_{DDA} = 3.3\text{ V}$, Peripherals = All on including MAC and PHY	120 MHz	MOSC with PLL	93.8	103.6	111.6	113.2	133.4	144.6	
			60 MHz	MOSC with PLL	66.9	76.7	78.7	80.0	100.0	111.9	
			16 MHz	PIOSC	12.6	19.0	20.1	21.3	39.1	50.3	
			1 MHz	PIOSC	5.73	10.6	11.7	12.8	30.9	42.2	
		$V_{DD} = 3.3\text{ V}$, $V_{DDA} = 3.3\text{ V}$, Peripherals = All on including MAC but not PHY	120 MHz	MOSC with PLL	67.2	76.1	84.0	85.4	102.3	113.0	
			60 MHz	MOSC with PLL	40.3	49.2	50.9	52.2	68.9	80.2	
			16 MHz	PIOSC	11.9	18.2	19.6	20.8	37.2	48.2	
			1 MHz	PIOSC	5.08	9.79	11.2	12.3	28.9	40.1	
		$V_{DD} = 3.3\text{ V}$, $V_{DDA} = 3.3\text{ V}$, Peripherals = All on except MAC and PHY	120 MHz	MOSC with PLL	65.4	74.3	82.0	83.2	100.1	110.6	
			60 MHz	MOSC with PLL	39.4	48.2	49.8	50.9	67.6	78.6	
			16 MHz	PIOSC	11.7	17.9	19.2	20.2	36.6	47.2	
			1 MHz	PIOSC	5.05	9.75	11.0	11.9	28.6	39.4	
$V_{DD} = 3.3\text{ V}$, $V_{DDA} = 3.3\text{ V}$, Peripherals = All off		120 MHz	MOSC with PLL	35.4	43.3	44.7	45.8	59.8	69.0		
		60 MHz	MOSC with PLL	23.4	29.4	30.7	31.7	45.5	54.9		
		16 MHz	PIOSC	7.08	12.4	13.6	14.6	28.7	38.0		
		1 MHz	PIOSC	4.60	8.78	10.0	11.0	25.3	34.9		

(1) Section 5.11 lists the current consumption that specific peripherals contribute to the run mode current consumption in Section 5.10. If these peripherals are not powered, then the peripheral current consumption can be subtracted from the run mode consumption in Section 5.10.

(2) Applicable to extended temperature devices only.

Current Consumption (continued)

over operating free-air temperature (unless otherwise noted) ⁽¹⁾

PARAMETER	TEST CONDITIONS	SYSTEM CLOCK		TYP				MAX		UNIT	
		FREQ	CLOCK SOURCE	-40°C	25°C	85°C	105°C	85°C	105°C ⁽²⁾		
I_{DD_SLEEP}	Sleep mode (FLASHPM = 0x0)	$V_{DD} = 3.3\text{ V}$, $V_{DDA} = 3.3\text{ V}$, Peripherals = All on including MAC and PHY, LDO = 1.2 V	120 MHz	MOSC with PLL	82.8	94.8	96.8	98.1	117.9	129.1	mA
			60 MHz	MOSC with PLL	60.8	69.2	71.2	72.3	91.8	102.9	
			16 MHz	PIOSC	11.2	16.8	18.1	19.1	35.4	45.9	
			1 MHz	PIOSC ⁽³⁾	5.10	10.3	11.5	12.6	28.9	39.6	
		$V_{DD} = 3.3\text{ V}$, $V_{DDA} = 3.3\text{ V}$, Peripherals = All on including MAC but not PHY, LDO = 1.2 V	120 MHz	MOSC with PLL	56.2	67.4	69.1	70.3	87.1	97.8	
			60 MHz	MOSC with PLL	34.4	41.9	43.4	44.5	60.7	71.6	
			16 MHz	PIOSC ⁽³⁾	10.6	16.2	17.5	18.5	34.5	45.1	
			1 MHz	PIOSC ⁽³⁾	4.47	9.60	10.9	12.0	28.0	38.7	
		$V_{DD} = 3.3\text{ V}$, $V_{DDA} = 3.3\text{ V}$, Peripherals = All on except MAC and PHY, LDO = 1.2 V	120 MHz	MOSC with PLL	54.4	65.6	67.1	68.1	84.9	95.4	
			60 MHz	MOSC with PLL	33.5	40.9	42.3	43.2	59.4	70.0	
			16 MHz	PIOSC ⁽³⁾	10.4	15.9	17.1	17.9	33.9	44.1	
			1 MHz	PIOSC ⁽³⁾	4.44	9.56	10.7	11.6	27.7	38.0	
	$V_{DD} = 3.3\text{ V}$, $V_{DDA} = 3.3\text{ V}$, Peripherals = All off, LDO = 1.2 V	120 MHz	MOSC with PLL	22.0	28.6	29.8	30.7	44.1	53.1		
		60 MHz	MOSC with PLL	16.3	22.0	23.2	24.1	37.5	46.6		
		16 MHz	PIOSC ⁽³⁾	5.37	10.4	11.5	12.4	26.1	35.1		
		1 MHz	PIOSC ⁽³⁾	4.37	8.60	9.71	10.6	24.6	33.9		
	Sleep mode (FLASHPM = 0x2)	$V_{DD} = 3.3\text{ V}$, $V_{DDA} = 3.3\text{ V}$, Peripherals = All on including MAC and PHY, LDO = 1.2 V	120 MHz	MOSC with PLL	86.5	89.0	91.2	92.5	112.1	123.5	
			60 MHz	MOSC with PLL	61.6	63.4	65.6	66.7	86.0	97.2	
			16 MHz	PIOSC ⁽³⁾	10.4	11.1	12.4	13.5	29.8	40.4	
			1 MHz	PIOSC ⁽³⁾	4.45	4.49	5.83	6.98	23.4	34.2	
		$V_{DD} = 3.3\text{ V}$, $V_{DDA} = 3.3\text{ V}$, Peripherals = All on including MAC but not PHY, LDO = 1.2 V	120 MHz	MOSC with PLL	59.9	61.7	63.4	64.7	81.3	92.1	
			60 MHz	MOSC with PLL	35.1	36.1	37.8	38.9	54.9	66.0	
			16 MHz	PIOSC ⁽³⁾	9.75	10.4	11.8	12.9	28.9	39.6	
			1 MHz	PIOSC ⁽³⁾	3.82	3.82	5.25	6.38	22.5	33.4	
		$V_{DD} = 3.3\text{ V}$, $V_{DDA} = 3.3\text{ V}$, Peripherals = All on except MAC and PHY, LDO = 1.2 V	120 MHz	MOSC with PLL	58.1	59.9	61.4	62.5	79.1	89.7	
			60 MHz	MOSC with PLL	34.2	35.1	36.7	37.6	53.6	64.4	
			16 MHz	PIOSC ⁽³⁾	9.50	10.1	11.4	12.3	28.3	38.6	
			1 MHz	PIOSC ⁽³⁾	3.79	3.78	5.06	5.96	22.2	32.7	
$V_{DD} = 3.3\text{ V}$, $V_{DDA} = 3.3\text{ V}$, Peripherals = All off, LDO = 1.2 V		120 MHz	MOSC with PLL	22.0	22.8	24.1	25.1	38.2	47.4		
		60 MHz	MOSC with PLL	15.7	16.2	17.5	18.5	31.7	40.9		
		16 MHz	PIOSC ⁽³⁾	4.50	4.60	5.80	6.80	20.5	29.8		
		1 MHz	PIOSC ⁽³⁾	3.00	2.80	4.10	5.20	19.1	28.7		

(3) If the MOSC is the source of the run-mode system clock and is powered down in sleep mode, wake time is increased by t_{MOSC_SETTLE} .

Current Consumption (continued)

over operating free-air temperature (unless otherwise noted) ⁽¹⁾

PARAMETER	TEST CONDITIONS	SYSTEM CLOCK		TYP				MAX		UNIT		
		FREQ	CLOCK SOURCE	-40°C	25°C	85°C	105°C	85°C	105°C ⁽²⁾			
$I_{DD_DEEPSLEEP}$	Deep-sleep mode (FLASHPM = 0x2)	$V_{DD} = 3.3\text{ V}$, $V_{DDA} = 3.3\text{ V}$, Peripherals = All on, LDO = 1.2 V	16 MHz	PIOSC	9.74	9.78	10.8	11.6	24.1	32.1	mA	
			30 kHz	LFIOSC	2.60	2.83	3.83	4.60	17.1	25.3		
		$V_{DD} = 3.3\text{ V}$, $V_{DDA} = 3.3\text{ V}$, Peripherals = All off, LDO = 1.2 V	16 MHz	PIOSC	4.53	4.05	4.88	5.53	15.9	22.7		
			30 kHz	LFIOSC	0.614	0.762	1.69	2.46	13.3	20.7		
		$V_{DD} = 3.3\text{ V}$, $V_{DDA} = 3.3\text{ V}$, Peripherals = All on, LDO = 0.9 V	16 MHz	PIOSC	5.21	7.33	7.97	8.48	15.3	20.1		
			30 kHz	LFIOSC	2.02	2.16	2.79	3.29	10.0	14.9		
I_{DDA_RUN} , I_{DDA_SLEEP}	All run modes	$V_{DD} = 3.3\text{ V}$, $V_{DDA} = 3.3\text{ V}$, Peripherals = All on	120 MHz	MOSC with PLL	2.61	2.66	2.68	2.66	3.03	3.35	mA	
			60 MHz	MOSC with PLL	2.61	2.66	2.68	2.66	3.04	3.10		
			16 MHz	PIOSC	2.45	2.49	2.50	2.48	2.85	2.95		
			1 MHz	PIOSC	2.45	2.48	2.50	2.48	2.84	2.90		
	All sleep modes	$V_{DD} = 3.3\text{ V}$, $V_{DDA} = 3.3\text{ V}$, Peripherals = All off	120 MHz	MOSC with PLL	0.227	0.229	0.270	0.250	0.559	0.650		
			60 MHz	MOSC with PLL	0.229	0.232	0.267	0.250	0.579	0.600		
			16 MHz	PIOSC	0.228	0.229	0.265	0.251	0.545	0.575		
			1 MHz	PIOSC	0.227	0.227	0.267	0.247	0.549	0.555		
$I_{DDA_DEEPSLEEP}$	Deep-sleep mode (FLASHPM = 0x2)	$V_{DD} = 3.3\text{ V}$, $V_{DDA} = 3.3\text{ V}$, Peripherals = All on, LDO = 1.2 V	16 MHz	PIOSC	2.45	2.48	2.50	2.48	2.84	2.90	mA	
			30 kHz	LFIOSC	2.45	2.48	2.50	2.48	2.85	2.90		
			$V_{DD} = 3.3\text{ V}$, $V_{DDA} = 3.3\text{ V}$, Peripherals = All off, LDO = 1.2 V	16 MHz	PIOSC	0.226	0.227	0.265	0.249	0.558		0.635
				30 kHz	LFIOSC	0.228	0.227	0.272	0.247	0.558		0.600
			$V_{DD} = 3.3\text{ V}$, $V_{DDA} = 3.3\text{ V}$, Peripherals = All on, LDO = 0.9 V ⁽⁴⁾	16 MHz	PIOSC	2.14	2.42	2.44	2.42	2.78		2.88
				30 kHz	LFIOSC	2.44	2.42	2.44	2.42	2.86		2.88
I_{HIB_NORTC}	Hibernate mode (external wake, RTC disabled)	$V_{BAT} = 3.0\text{ V}$, $V_{DD} = 0\text{ V}$, $V_{DDA} = 0\text{ V}$, System clock = OFF, Hibernate module = 32.768 kHz			1.04	1.20	1.44	1.69	1.62	2.14	μA	
I_{HIB_RTC}	Hibernate mode (RTC enabled)	$V_{BAT} = 3.0\text{ V}$, $V_{DD} = 0\text{ V}$, $V_{DDA} = 0\text{ V}$, System clock = OFF, Hibernate module = 32.768 kHz			1.12	1.29	1.54	1.82	1.75	2.33	μA	

(4) See the System Control chapter of the [MSP432E4 SimpleLink™ Microcontrollers Technical Reference Manual](#) for information on lowering the LDO voltage to 0.9 V.

Current Consumption (continued)

over operating free-air temperature (unless otherwise noted) ⁽¹⁾

PARAMETER	TEST CONDITIONS	SYSTEM CLOCK		TYP				MAX		UNIT
		FREQ	CLOCK SOURCE	-40°C	25°C	85°C	105°C	85°C	105°C ⁽²⁾	
I _{HIB_VDD3ON}	Hibernate mode (VDD3ON mode, tamper enabled)			6.78	7.99	17.0	22.1	31.0	46.2	μA
	Hibernate mode (VDD3ON mode, tamper disabled)			5.42	6.39	15.4	17.8	28.9	32.0	

5.11 Peripheral Current Consumption

over operating free-air temperature (unless otherwise noted)

PARAMETER	TEST CONDITIONS	SYSTEM CLOCK	TYP	UNIT
I _{DDUSB}	USB (including USB PHY) run mode current	120 MHz (MOSC with PLL)	4.0	mA
I _{DDEMAC}	Ethernet MAC run mode current	120 MHz (MOSC with PLL)	1.9	mA
I _{DDEMACPHY}	Ethernet MAC and PHY run mode current	120 MHz (MOSC with PLL)	30	mA

5.12 LDO Regulator Characteristics

over operating free-air temperature (unless otherwise noted)

PARAMETER	MIN	TYP	MAX	UNIT
C _{LDO}	External filter capacitor size for internal power supply ⁽¹⁾		4.0	μF
ESR	Filter capacitor equivalent series resistance		100	mΩ
ESL	Filter capacitor equivalent series inductance		0.5	nH
V _{LDO}	LDO output voltage, run mode		1.27	V
I _{INRUSH}	Inrush current		250	mA

(1) Connect the capacitor as close as possible to pin 115.

5.13 Power Dissipation

over operating free-air temperature (unless otherwise noted) ⁽¹⁾ ⁽²⁾

PARAMETER		T _A	T _J	MIN	MAX	UNIT
P _{DE}	Extended temperature device power dissipation	105°C (extended temperature part)	125°C (extended temperature part)		452	mW

- (1) If the device exceeds the power dissipation value shown, then modifications such as heat sinks or fans must be used to conform to the limits shown.
- (2) A larger power dissipation allowance can be achieved by lowering T_A as long as T_{JMAX} shown in [Section 5.1](#) is not exceeded.

5.14 Thermal Resistance Characteristics, 128-Pin PDT (TQFP) Package

over operating free-air temperature range (unless otherwise noted)

THERMAL METRIC		VALUE	UNIT
θ _{JA}	Thermal resistance (junction to ambient) ⁽¹⁾	44.2	°C/W
θ _{JB}	Thermal resistance (junction to board) ⁽¹⁾	22.4	°C/W
θ _{JC}	Thermal resistance (junction to case) ⁽¹⁾	6.8	°C/W
Ψ _{JT}	Thermal metric (junction to top of package)	0.2	°C/W
Ψ _{JB}	Thermal metric (junction to board)	22.1	°C/W
T _J	Junction temperature formula	$T_C + (P \times \Psi_{JT})$ ⁽²⁾ $T_{PCB} + (P \times \Psi_{JB})$ ⁽³⁾ $T_A + (P \times \theta_{JA})$ ⁽⁴⁾ $T_B + (P \times \theta_{JB})$ ^{(5) (6)}	°C

- (1) Junction to ambient thermal resistance (θ_{JA}), junction to board thermal resistance (θ_{JB}), and junction to case thermal resistance (θ_{JC}) numbers are determined by a package simulator.
- (2) T_C is the case temperature and P is the device power consumption.
- (3) T_{PCB} is the temperature of the board acquired by following the steps listed in the EAI/JESD 51-8 standard summarized in [Semiconductor and IC Package Thermal Metrics](#). P is the device power consumption.
- (4) Because θ_{JA} is highly variable and based on factors such as board design, chip size, pad size, altitude, and external ambient temperature, TI recommends using the equations that contain Ψ_{JT} and Ψ_{JB} for best results.
- (5) T_B is temperature of the board.
- (6) θ_{JB} is not a pure reflection of the internal resistance of the package because it includes the resistance of the testing board and environment. TI recommends using equations that contain Ψ_{JT} and Ψ_{JB} for best results.

5.15 Timing and Switching Characteristics

5.15.1 Load Conditions

表 5-2 shows the load conditions used for timing measurements, and 表 5-2 lists the load values for the specified signals.



图 5-1. Load Conditions

表 5-2. Load Conditions

SIGNALS	LOAD VALUE (C _L)
EPIOS[35:0] SDRAM interface	30 pF
EPIOS[35:0] general-purpose interface	
EPIOS[35:0] host-bus interface	
EPIOS[35:0] PSRAM interface	40 pF
All other digital I/O signals	50 pF

5.15.2 Power Supply Sequencing

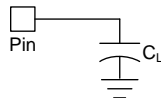
To ensure proper operation, power on V_{D_{DDA}} before V_{DD} if sourced from different supplies, or connect V_{D_{DDA}} to the same supply as V_{DD}. No restriction exists for powering off.

5.15.2.1 Power and Brownout

表 5-3. Power and Brownout Levels

over operating free-air temperature (unless otherwise noted)

NO.	PARAMETER		MIN	TYP	MAX	UNIT
P1	t _{V_{DDA}_RISE}	Analog supply voltage (V _{DDA}) rise time			∞	μs
P2	t _{V_{DD}_RISE}	I/O supply voltage (V _{DD}) rise time			∞	μs
P3	t _{V_{DDC}_RISE}	Core supply voltage (V _{DDC}) rise time	10		150	μs
P4	V _{POR}	Power-on reset threshold (rising edge)	1.98	2.35	2.72	V
		Power-on reset threshold (falling edge)	1.84	2.20	2.56	
		Power-on reset hysteresis	0.06	0.15	0.24	
P5	V _{D_{DDA}_POK}	V _{DDA} power-OK threshold (rising edge)	2.67	2.82	2.97	V
P6	V _{D_{DDA}_BOR0}	V _{DDA} brownout reset threshold	2.71	2.80	2.89	V
P7	V _{D_{DD}_POK}	V _{DD} power-OK threshold (rising edge)	2.65	2.80	2.90	V
		V _{DD} power-OK threshold (falling edge)	2.67	2.76	2.85	
P8	V _{D_{DD}_BOR0}	V _{DD} brownout reset threshold	2.77	2.86	2.95	V
P9	V _{D_{DDC}_POK}	V _{DDC} power-OK threshold (rising edge)	0.85	0.95	1.10	V
		V _{DDC} power-OK threshold (falling edge)	0.71	0.80	0.85	

5.15.2.1.1 V_{DDA} Levels

The V_{DDA} supply has three monitors:

- Power-on reset (POR)
- Power-OK (POK)
- Brownout reset (BOR)

The POR monitor is used to keep the analog circuitry in reset until the V_{DDA} supply reaches the correct range for the analog circuitry to begin operating. The POK monitor is used to keep the digital circuitry in reset until the V_{DDA} power supply is at an acceptable operational level. The digital reset is only released when the Power-On Reset has deasserted and the Power-OK monitor for each supply indicates that power levels are in operational ranges. The BOR monitor is used to generate a reset to the device or assert an interrupt if the V_{DDA} supply drops below its operational range.

注

V_{DDA} BOR and V_{DD} BOR events are a combined BOR to the system logic, such that if either BOR event occurs, the following bits are affected:

- The BORRIS bit in the Raw Interrupt Status (RIS) register, System Control offset 0x050
- The BORMIS bit in the Masked Interrupt Status and Clear (MISC) register, System Control offset 0x058. This bit is set only if the BORIM bit in the Interrupt Mask Control (IMC) register has been set.
- The BOR bit in the Reset Cause (RESC) register, System Control offset 0x05C. This bit is set only if either of the BOR events have been configured to initiate a reset.

In addition, the following bits control both BOR events:

- The BORIM bit in the Interrupt Mask Control (IMC) register, System Control offset 0x054
- The V_{DDA_UBOR0} and V_{DD_UBOR0} bits in the Power-Temperature Cause (PWRTC) register

See the *System Control* chapter of the [MSP432E4 SimpleLink™ Microcontrollers Technical Reference Manual](#) for more information on how to configure these registers.

图 5-2 shows the relationship between V_{DDA} , POK, POR, and a BOR event.



图 5-2. Power and Brownout Assertions vs V_{DDA} Levels

5.15.2.1.2 V_{DD} Levels

The V_{DD} supply has two monitors:

- Power-OK (POK)
- Brownout reset (BOR)

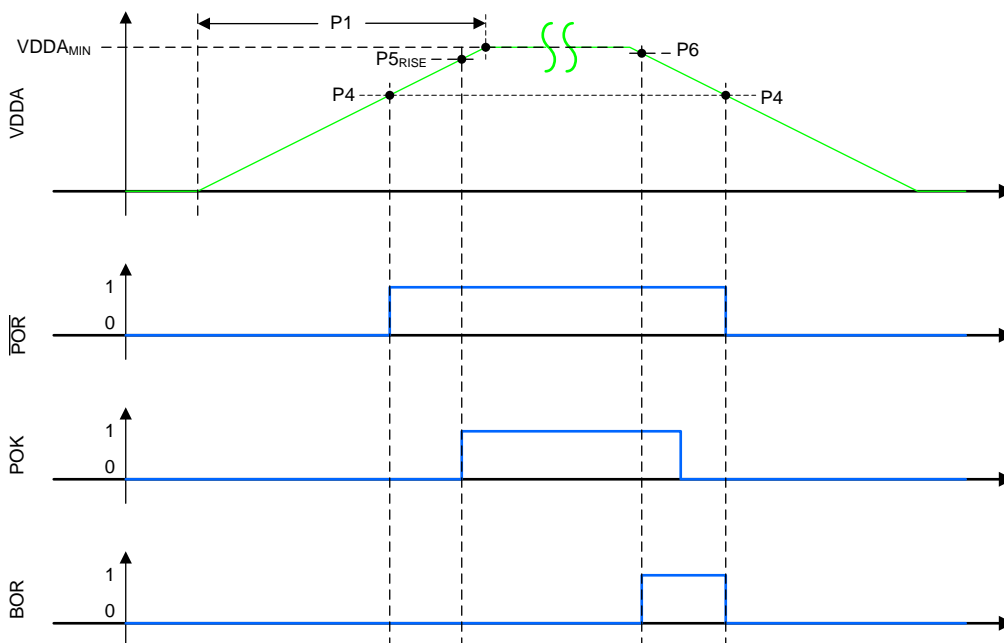
The POK monitor is used to keep the digital circuitry in reset until the V_{DD} power supply reaches an acceptable operational level. The digital reset is only released when the POR has deasserted and the POK monitor for each supply indicates that power levels are in operational ranges. The BOR monitor is used to generate a reset to the device or assert an interrupt if the V_{DD} supply drops below its operational range.

注

V_{DDA} BOR and V_{DD} BOR events are a combined BOR to the system logic, such that if either BOR event occurs, the following bits are affected:

- The BORRIS bit in the Raw Interrupt Status (RIS) register, System Control offset 0x050
- The BORMIS bit in the Masked Interrupt Status and Clear (MISC) register, System Control offset 0x058. This bit is set only if the BORIM bit in the Interrupt Mask Control (IMC) register has been set.
- The BOR bit in the Reset Cause (RESC) register, System Control offset 0x05C. This bit is set only if either of the BOR events have been configured to initiate a reset.

In addition, the following bits control both BOR events:

- The BORIM bit in the Interrupt Mask Control (IMC) register, System Control offset 0x054
- The VDDA_UBOR0 and VDD_UBOR0 bits in the Power-Temperature Cause (PWRTC) register

See the *System Control* chapter of the [MSP432E4 SimpleLink™ Microcontrollers Technical Reference Manual](#) for more information on how to configure these registers.

图 5-3 shows the relationship between V_{DD} , POK, POR, and a BOR event.



图 5-3. Power and Brownout Assertions vs V_{DD} Levels

5.15.2.1.3 V_{DDC} Levels

The V_{DDC} supply has one monitor, the Power-OK (POK). The POK monitor is used to keep the digital circuitry in reset until the V_{DDC} power supply reaches an acceptable operational level. The digital reset is only released when the power-on reset has deasserted and the POK monitor for each supply indicates that power levels are in operational ranges. 图 5-4 shows the relationship between POK and V_{DDC} .

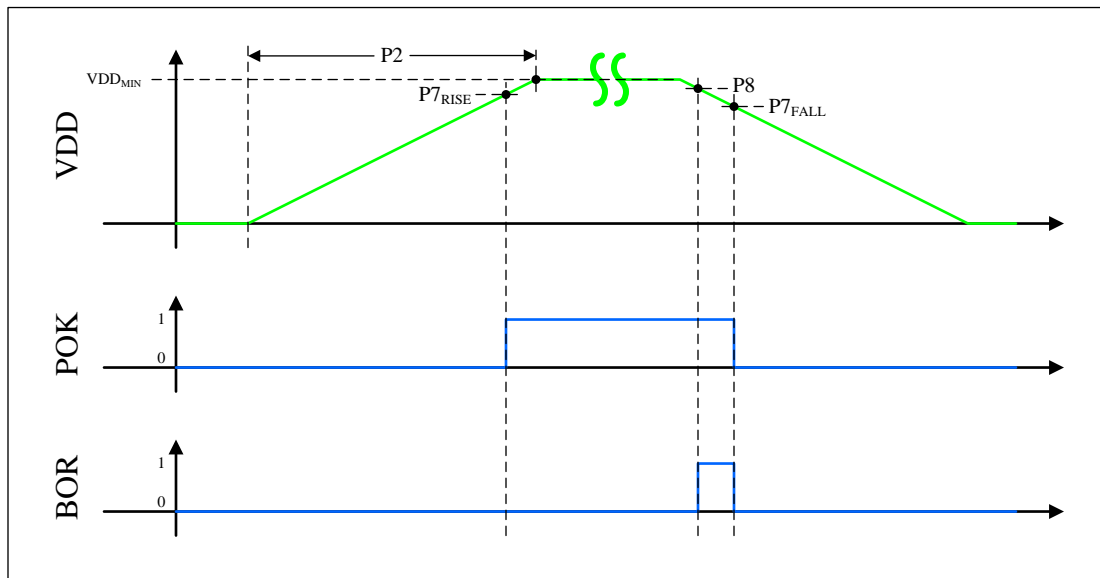

图 5-4. POK Assertion vs V_{DDC}

5.15.2.1.4 V_{DD} Glitch Response

图 5-5 shows the response of the BOR and the POR circuit to glitches on the V_{DD} supply.

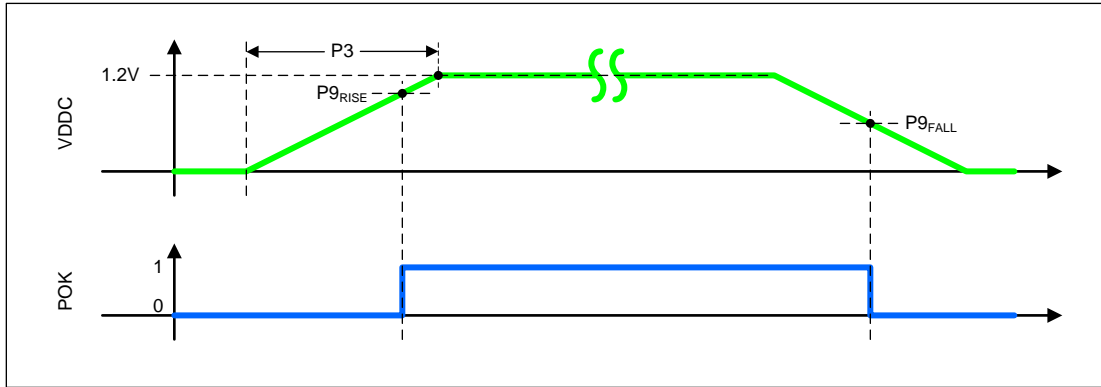

图 5-5. POR-BOR V_{DD} Glitch Response

5.15.2.1.5 V_{DD} Droop Response

图 5-6 shows the response of the BOR and the POR monitors to a drop on the V_{DD} supply.

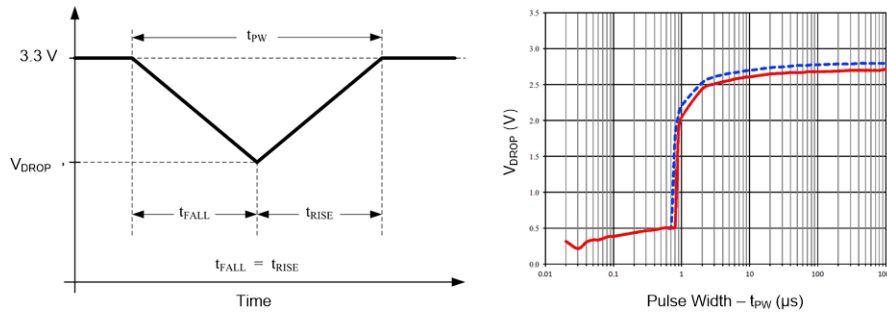

图 5-6. POR-BOR V_{DD} Droop Response

5.15.3 Reset Timing

表 5-4 lists the reset characteristics.

表 5-4. Reset Characteristics

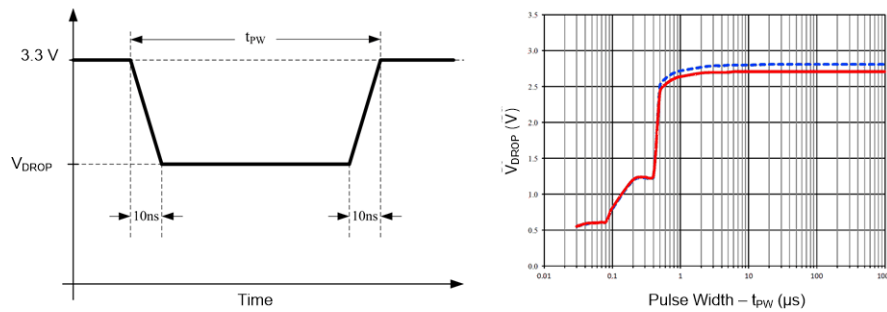
over operating free-air temperature (unless otherwise noted)

NO.	PARAMETER		MIN	TYP	MAX	UNIT
R1	$t_{DPORDLY}$	Digital POR to internal reset assertion delay (see 图 5-7)	0.44		126	μs
R2	$t_{IRTOU}^{(1)(2)}$	Standard internal reset time		14	16	ms
		Internal reset time with recovery code repair (program or erase) ⁽³⁾	24.4		6400 ⁽⁴⁾	
R3	$t_{BOR0DLY}^{(1)}$	BOR0 to internal reset assertion delay ⁽⁵⁾ (see 图 5-8)	0.44		125	μs
R4	t_{RSTMIN}	Minimum \overline{RST} pulse duration		0.25 ⁽⁶⁾ or 100 ⁽⁷⁾		μs
R5	$t_{IRHWDLY}$	\overline{RST} to internal reset assertion delay (see 图 5-9)		0.85		μs
R6	$t_{IRSWR}^{(1)}$	Internal reset time-out after software-initiated system reset (see 图 5-10)		2.44		μs
R7	$t_{IRWDR}^{(1)}$	Internal reset time-out after watchdog reset (see 图 5-11)		2.44		μs
R8	$t_{IRMFR}^{(1)}$	Internal reset time-out after MOSC failure reset (see 图 5-12)		2.44		μs

- (1) These values are based on simulation.
- (2) This is the delay from the time POR is released until the reset vector is fetched.
- (3) This parameter applies only in situations where a power-loss or brownout event occurs during an EEPROM program or erase operation, and EEPROM must be repaired (which is a rare case). For all other sequences, there is no change to normal POR timing. This delay is in addition to other POR delays.
- (4) This value represents the maximum internal reset time when the EEPROM reaches its endurance limit.
- (5) Timing values depend on the V_{DD} power-down ramp rate.
- (6) Standard operation
- (7) Deep-sleep operation with PIOSC powered down



图 5-7. Digital Power-On Reset Timing

The digital power-on reset is released only when the analog power-on reset has deasserted and the Power-OK monitor for each supply indicates that power levels are in operational ranges.



图 5-8. Brownout Reset Timing

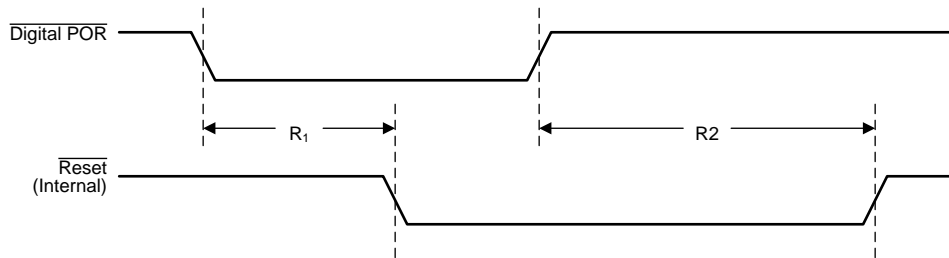

图 5-9. External Reset Timing ($\overline{\text{RST}}$)

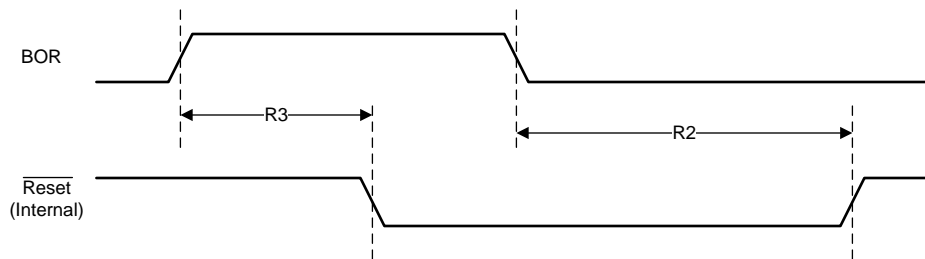

图 5-10. Software Reset Timing

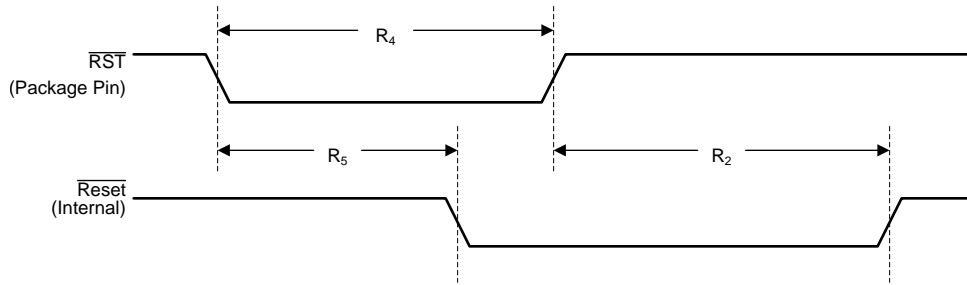

图 5-11. Watchdog Reset Timing

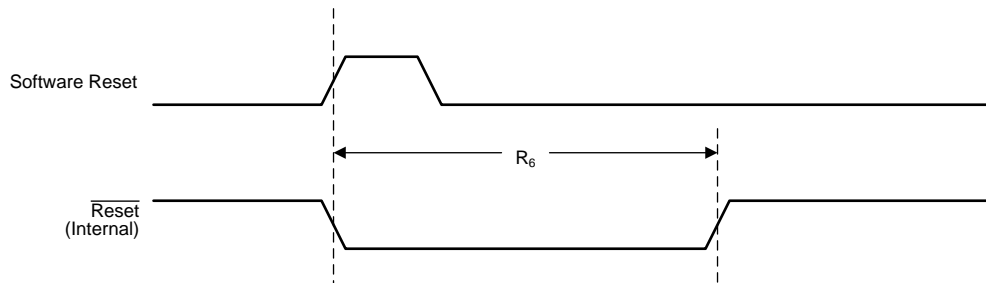

图 5-12. MOSC Failure Reset Timing

5.15.4 Clock Specifications

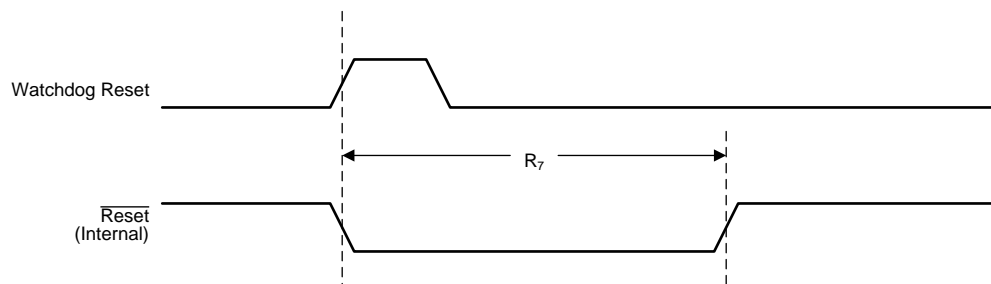
The following sections provide specifications on the various clock sources and mode.

5.15.4.1 PLL Specifications

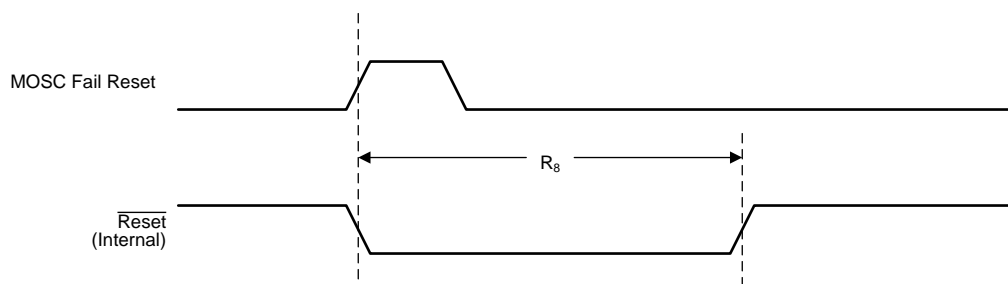
表 5-5 lists the PLL characteristics.

注

If the integrated Ethernet PHY is used, f_{REF_XTAL} and f_{REF_EXT} must be 25 MHz.

表 5-5. Phase Locked Loop (PLL) Characteristics

over operating free-air temperature (unless otherwise noted)

PARAMETER		MIN	MAX	UNIT
f_{REF_XTAL}	Crystal reference	5	25	MHz
f_{REF_EXT}	External clock reference	5	25	MHz
f_{PLL}	PLL VCO frequency at 1.2 V ⁽¹⁾	100	480	MHz
f_{PLLS}	PLL VCO frequency at 0.9 V ⁽²⁾	100	480	MHz
t_{READY}	PLL lock time	Enabling the PLL, when PLL is transitioning from power down to power up	512 × (reference clock period)	μs
		When the PLL VCO frequency is changed (PLL is already enabled)	128 × (reference clock period)	
		Changing the OSCSRC between MOSC and PIOSC	128 × (reference clock period)	

(1) PLL frequency is manually calculated using the values in the PLLFREQ0 and PLLFREQ1 registers.

(2) If the LDO is dropped to 0.9 V, the system must be run 1/4 of the maximum frequency at most. The Q value in the PLLFREQ1 register must be set to 0x3 rather than using the PSYSDIV field in the RSCLKCFG register for the divisor.

5.15.4.1.1 PLL Configuration

The PLL is disabled by default during power-on reset and is enabled later by software if required. Software specifies the output divisor to set the system clock frequency and enables the PLL to drive the output. The PLL is controlled using the PLLFREQ0, PLLFREQ1, and PLLSTAT registers. Changes made to these registers do not become active until after the NEWFREQ bit in the RSCLKCFG register is enabled. The clock source for the main PLL is selected by configuring the PLLSRC field in the Run and Sleep Clock Configuration (RSCLKCFG) register. The PLL allows for the generation of system clock frequencies in excess of the reference clock provided. The reference clocks for the PLL are the PIOSC and the MOSC.

The PLL is controlled by two registers, PLLFREQ0 and PLLFREQ1. The PLL VCO frequency (f_{VCO}) is determined through 公式 1.

$$f_{VCO} = f_{IN} \times MDIV$$

where

- $f_{IN} = f_{XTAL} / (Q+1)(N+1)$ or $f_{PIOSC} / (Q+1)(N+1)$
- $MDIV = MINT + (MFRAC / 1024)$

The Q and N values are programmed in the PLLFREQ1 register. To reduce jitter, program MFRAC to 0x0.

When the PLL is active, the system clock frequency (SysClk) is calculated using 公式 2.

$$SysClk = f_{VCO} / (1 + 1)$$

The PLL system divisor factor (PSYSDIV) must be set as 1. 表 5-6 lists examples of the system clock frequency.

表 5-6. Examples of System Clock Frequencies

f_{VCO} (MHz)	Q	PSYSDIV + 1	System Clock (SYSCLK) Frequency (MHz)
480	2	2	120
480	3	2	80
480	4	2	60
480	5	2	48
320	2	2	80
320	3	2	53
320	4	2	40

If the main oscillator provides the clock reference to the PLL, the translation provided by hardware and used to program the PLL is available for software in the PLL Frequency n (PLLFRQn) registers. The internal translation provides a translation within $\pm 1\%$ of the targeted PLL VCO frequency. 表 5-7 shows the actual PLL frequency and error for a given crystal choice.

表 5-7 provides examples of the programming expected for the PLLFRQ0 and PLLFRQ1 registers. The CRYSTAL FREQUENCY column specifies the input crystal frequency and the PLL FREQUENCY column displays the PLL frequency given the values of MINT and N, when Q = 0.

表 5-7. Actual PLL Frequency⁽¹⁾

CRYSTAL FREQUENCY (MHz)	MINT		N	REFERENCE FREQUENCY (MHz) ⁽²⁾	PLL FREQUENCY (MHz)
	DECIMAL VALUE	HEXADECIMAL VALUE			
5	64	0x40	0x0	5	320
6	160	0x35	0x2	2	320
8	40	0x28	0x0	8	320
10	32	0x20	0x0	10	320
12	80	0x50	0x2	4	320
16	20	0x14	0x0	16	320
18	160	0xA0	0x8	2	320
20	16	0x10	0x0	20	320
24	40	0x28	0x2	8	320
25	64	0x40	0x4	5	320
5	96	0x60	0x0	5	480
6	80	0x50	0x0	6	480
8	60	0x3C	0x0	8	480
10	48	0x30	0x0	10	480
12	40	0x28	0x0	12	480
16	30	0x1E	0x0	16	480
18	80	0x50	0x2	6	480
20	24	0x18	0x0	20	480
24	20	0x14	0x0	24	480
25	96	0x60	0x4	5	480

(1) For all examples listed, Q = 0.

(2) For a given crystal frequency, N should be chosen such that the reference frequency is 4 to 30 MHz.

5.15.4.2 PIOSC Specifications

表 5-8 lists the PIOSC characteristics.

表 5-8. PIOSC Clock Characteristics

PARAMETER		MIN	NOM	MAX	UNIT
f _{PIOSC}	Factory calibration, 0°C to 105°C: Internal 16-MHz precision oscillator frequency variance across voltage and temperature range when factory calibration is used			±6%	
	Factory calibration, -40°C to <0°C			±10%	
	Recalibration: Internal 16-MHz precision oscillator frequency variance when recalibration is used at a specific temperature			±1%	
t _{START}	PIOSC start-up time ⁽¹⁾			1	µs

(1) PIOSC start-up time is part of reset and is included in the internal reset time-out value (T_{IRTOU}) in 表 5-4. The T_{START} value is based on simulation.

5.15.4.3 Low-Frequency Oscillator Specifications

表 5-9 lists the characteristics of the low-frequency oscillator.

表 5-9. Low-Frequency Oscillator Characteristics

PARAMETER		MIN	NOM	MAX	UNIT
f _{LFOSC}	Internal low-frequency oscillator frequency	10	33	75	kHz

5.15.4.4 Hibernation Low-Frequency Oscillator Specifications

表 5-10. Hibernation External Oscillator (XOSC) Input Characteristics

PARAMETER		MIN	NOM	MAX	UNIT
f _{HIBXOSC} ⁽¹⁾	Parallel resonance frequency		32.768		kHz
C ₁ , C ₂	External load capacitance on XOSC0, XOSC1 pins ⁽²⁾	12		24	pF
C _{PKG}	Device package stray shunt capacitance ⁽²⁾		0.5		pF
C _{PCB}	PCB stray shunt capacitance ⁽²⁾		0.5		pF
C _{SHUNT}	Total shunt capacitance ⁽²⁾			4	pF
ESR	Crystal effective series resistance, OSCDRV = 0 ⁽³⁾			50	kΩ
	Crystal effective series resistance, OSCDRV = 1 ⁽³⁾			75	
DL	Oscillator output drive level			0.25	µW
t _{START}	Oscillator start-up time, when using a crystal ⁽⁴⁾		600	1500 ⁽⁵⁾	ms
V _{IH}	CMOS input high level, when using an external oscillator with V _{Supply} > 3.3 V	2.64			V
	CMOS input high level, when using an external oscillator with 1.8 V ≤ V _{Supply} ≤ 3.3 V	0.8 × V _{Supply}			
V _{IL} ⁽⁶⁾	CMOS input low level, when using an external oscillator with 1.8 V ≤ V _{Supply} ≤ 3.63 V			0.2 × V _{Supply}	V
V _{HYS} ⁽⁶⁾	CMOS input buffer hysteresis, when using an external oscillator with 1.8 V ≤ V _{Supply} ≤ 3.63 V	360	960	1390	mV
DC _{HIBOSC_EXT}	External single-ended (bypass) reference duty cycle	30%		70%	

(1) The Hibernation XOSC pins are not fail-safe and must follow the limits in 节 5.15.9.1.2.

(2) See the additional information about the load capacitors following this table.

(3) Crystal ESR specified by crystal manufacturer.

(4) Oscillator start-up time is specified from the time the oscillator is enabled to when it reaches a stable point of oscillation such that the internal clock is valid.

(5) Only valid for recommended supply conditions. Measured with OSCDRV bit set (high drive strength enabled, 24 pF).

(6) Specification is relative to the larger of V_{DD} or V_{BAT}.

Choose the load capacitors added on the board, C_1 and C_2 , such that 公式 3 is satisfied (see 表 5-10 for typical values).

$$C_L = (C_1 \times C_2) / (C_1 + C_2) + C_{SHUNT}$$

where

- C_L = load capacitance specified by crystal manufacturer
- $C_{SHUNT} = C_{PKG} + C_{PCB} + C_0$ (total shunt capacitance seen across XOSC0 and XOSC1)
- C_{PKG} , C_{PCB} as measured across the XOSC0 and XOSC1 pins excluding the crystal
- Clear the OSCDRV bit in the Hibernation Control (HIBCTL) register for $C_{1,2} \leq 18$ pF
- Set the OSCDRV bit for $C_{1,2} > 18$ pF
- C_0 = Shunt capacitance of crystal specified by the crystal manufacturer

表 5-11 lists the characteristics of the Hibernation module low-frequency oscillator.

表 5-11. Hibernation Internal Low-Frequency Oscillator Clock Characteristics

PARAMETER		MIN	NOM	MAX	UNIT
$f_{HIBLFOSC}$	Internal low-frequency hibernation oscillator frequency	10	33	90	kHz

5.15.4.5 Main Oscillator Specifications

表 5-12 lists the required characteristics of the main oscillator input.

表 5-12. Main Oscillator Input Characteristics

over operating free-air temperature (unless otherwise noted)⁽¹⁾

PARAMETER		MIN	NOM	MAX	UNIT
f_{MOSC}	Parallel resonance frequency	4 ⁽²⁾		25	MHz
$f_{REF_XTAL_BYPASS}$	External clock reference (PLL in BYPASS mode)	0		120	MHz
C_1, C_2	External load capacitance on OSC0, OSC1 pins ⁽³⁾	12		24	pF
C_{PKG}	Device package stray shunt capacitance ⁽³⁾		0.5		pF
C_{PCB}	PCB stray shunt capacitance ⁽³⁾		0.5		pF
C_{SHUNT}	Total shunt capacitance ⁽³⁾			4	pF
ESR	Crystal effective series resistance	4 MHz ^{(4) (5)}		300	Ω
		6 MHz ^{(4) (5)}		200	
		8 MHz ^{(4) (5)}		130	
		12 MHz ^{(4) (5)}		120	
		16 MHz ^{(4) (5)}		100	
		25 MHz ^{(4) (5)}		50	
DL	Oscillator output drive level ⁽⁶⁾		OSC_{PWR}		mW
T_{START}	Oscillator start-up time, when using a crystal ⁽⁷⁾			18	ms
V_{IH}	CMOS input high level, when using an external oscillator	$0.65 \times V_{DD}$		V_{DD}	V
V_{IL}	CMOS input low level, when using an external oscillator	GND		$0.35 \times V_{DD}$	V
V_{HYS}	CMOS input buffer hysteresis, when using an external oscillator	150			mV
DC_{OSC_EXT}	External clock reference duty cycle	45%		55%	

(1) See 表 5-39 and 表 5-40 for additional Ethernet crystal requirements.

(2) 5 MHz is the minimum when using the PLL.

(3) See the additional information about the load capacitors following this table.

(4) Crystal ESR specified by crystal manufacturer.

(5) Crystal vendors can be contacted to confirm these specifications are met for a specific crystal part number if the vendors generic crystal datasheet show limits outside of these specifications.

(6) $OSC_{PWR} = (2 \times \pi \times F_P \times C_L \times 2.5)^2 \times ESR / 2$. An estimation of the typical power delivered to the crystal is based on the C_L , F_P and ESR parameters of the crystal in the circuit as calculated by the OSC_{PWR} equation. Ensure that the value calculated for OSC_{PWR} does not exceed the crystal's drive-level maximum.

(7) Oscillator start-up time is specified from the time the oscillator is enabled to when it reaches a stable point of oscillation such that the internal clock is valid.

The load capacitors added on the board, C_1 and C_2 , should be chosen such that 公式 4 is satisfied (see 表 5-12 for typical values and 表 5-13 for detailed crystal parameter information).

$$C_L = (C_1 \times C_2) / (C_1 + C_2) + C_{SHUNT}$$

where

- C_L = load capacitance specified by crystal manufacturer
 - $C_{SHUNT} = C_0 + C_{PKG} + C_{PCB}$ (total shunt capacitance seen across OSC0 and OSC1 crystal inputs)
 - C_{PKG}, C_{PCB} = Mutual capacitance as measured across the OSC0 and OSC1 pins excluding the crystal
 - C_0 = Shunt capacitance of crystal specified by the crystal manufacturer
- (4)

表 5-13 lists part numbers of crystals that have been simulated and confirmed to operate within the specifications in 表 5-12. Other crystals that have nearly identical crystal parameters can be expected to work as well.

In 表 5-13, the crystal parameters labeled C_0 , C_1 , and L_1 are values that are obtained from the crystal manufacturer. These numbers are usually a result of testing a relevant batch of crystals on a network analyzer. The parameters labeled ESR, DL, and C_L are maximum numbers usually available in the data sheet for a crystal.

表 5-13 also includes three columns of Recommended Component Values. These values apply to system board components. C_1 and C_2 are the values in picofarads of the load capacitors that should be put on each leg of the crystal pins to ensure oscillation at the correct frequency. R_s is the value in $k\Omega$ of a resistor that is placed in series with the crystal between the OSC1 pin and the crystal pin. R_s dissipates some of the power so the Max DI crystal parameter is not exceeded. Only use the recommended C_1 , C_2 , and R_s values with the associated crystal part. The values in the table were used in the simulation to ensure crystal start-up and to determine the worst-case drive level (WC DL). The value in the WC DL column should not be greater than the Max DL crystal parameter. The WC DL value can be used to determine if a crystal with similar parameter values but a lower Max DL value is acceptable.

表 5-13. Crystal Parameters

Manufacturer	Manufacturer Part Number	Holder	Package Size (mm x mm)	Frequency (MHz)	Crystal Specification (Tolerance / Stability)	Crystal Parameters						Recommended Component Values			WC DL (μ W)
						Typical Values			Max Values			C ₁ (pF)	C ₂ (pF)	R _S (k Ω)	
						C0 (pF)	C1 (fF)	L1 (mH)	ESR (Ω)	Max DL (μ W)	C _L (pf)				
NDK	NX8045GB-4.000M-STD-CJL-5	NX8045GB	8 x 4.5	4	30 / 50 ppm	1.00	2.70	598.10	300	500	8	12	12	0	132
FOX	FQ1045A-4	2-SMD	10 x 4.5	4	30 / 30 ppm	1.18	4.05	396.00	150	500	10	14	14	0	103
NDK	NX8045GB-5.000M-STD-CSF-4	NX8045GB	8 x 4.5	5	30 / 50 ppm	1.00	2.80	356.50	250	500	8	12	12	0	164
NDK	NX8045GB-6.000M-STD-CSF-4	NX8045GB	8 x 4.5	6	30 / 50 ppm	1.30	4.10	173.20	250	500	8	12	12	0	214
FOX	FQ1045A-6	2-SMD	10 x 4.5	6	30 / 30 ppm	1.37	6.26	112.30	150	500	10	14	14	0	209
NDK	NX8045GB-8.000M-STD-CSF-6	NX8045GB	8 x 4.5	8	30 / 50 ppm	1.00	2.80	139.30	200	500	8	12	12	0	277
FOX	FQ7050B-8	4-SMD	7 x 5	8	30 / 30 ppm	1.95	6.69	59.10	80	500	10	14	14	0	217
ECS	ECS-80-16-28A-TR	HC49/US	12.5 x 4.85	8	50 / 30 ppm	1.82	4.90	85.70	80	500	16	24	24	0	298
Abracon	AABMM-12.000MHZ-10-D-1-X-T	ABMM	7.2 x 5.2	12	10 / 20 ppm	2.37	8.85	20.5	50	500	10	12	12	2.0 ⁽¹⁾	124
NDK	NX3225GA-12.000MHZ-STD-CRG-2	NX3225GA	3.2 x 2.5	12	20 / 30 ppm	0.70	2.20	81.00	100	200	8	12	12	2.5	147
NDK	NX5032GA-12.000MHZ-LN-CD-1	NX5032GA	5 x 3.2	12	30 / 50 ppm	0.93	3.12	56.40	120	500	8	12	12	0	362
FOX	FQ5032B-12	4-SMD	5 x 3.2	12	30 / 30 ppm	1.16	4.16	42.30	80	500	10	14	14	0	370
Abracon	AABMM-16.000MHZ-10-D-1-X-T	ABMM	7.2 x 5.2	16	10 / 20 ppm	3.00	11.00	9.30	50	500	10	12	12	2.0 ⁽¹⁾	143
Ecliptek	ECX-6595-16.000M	HC-49/UP	13.3 x 4.85	16	15 / 30 ppm	3.00	12.7	8.1	50	1000	10	12	12	2.0 ⁽¹⁾	139
NDK	NX3225GA-16.000MHZ-STD-CRG-2	NX3225GA	3.2 x 2.5	16	20 / 30 ppm	1.00	2.90	33.90	80	200	8	12	12	2	188
NDK	NX5032GA-16.000MHZ-LN-CD-1	NX5032GA	5 x 3.2	16	30 / 50 ppm	1.02	3.82	25.90	120 ⁽²⁾	500	8	10	10	0	437
ECS	ECS-160-9-42-CKM-TR	ECX-42	4 x 2.5	16	10 / 10 ppm	1.47	3.90	25.84	60	300	9	12	12	0.5	289
Abracon	AABMM-25.000MHZ-10-D-1-X-T	ABMM	7.2 x 5.2	25	10 / 20 ppm	3.00	11.00	3.70	50	500	10	12	12	2.0 ⁽¹⁾	158
Ecliptek	ECX-6593-25.000M	HC-49/UP	13.3 x 4.85	25	15 / 30 ppm	3.00	12.8	3.2	40	1000	10	12	12	1.5 ⁽¹⁾	159
NDK	NX3225GA-25.000MHZ-STD-CRG-2	NX3225GA	3.2 x 2.5	25	20 / 30 ppm	1.10	4.70	8.70	50	200	8	12	12	2	181

(1) R_S values as low as 0 Ω can be used. Using a lower R_S value causes the WC DL to increase toward the maximum DL of the crystal.

(2) Although this ESR value is outside of the recommended crystal ESR maximum for this frequency, this crystal has been simulated to confirm proper operation and is valid for use with this device.

表 5-13. Crystal Parameters (continued)

Manufacturer	Manufacturer Part Number	Holder	Package Size (mm × mm)	Frequency (MHz)	Crystal Specification (Tolerance / Stability)	Crystal Parameters						Recommended Component Values			WC DL (μW)
						Typical Values			Max Values			C ₁ (pF)	C ₂ (pF)	R _s (kΩ)	
						C ₀ (pF)	C ₁ (fF)	L ₁ (mH)	ESR (Ω)	Max DL (μW)	C _L (pf)				
NDK	NX5032GA-25.000MHZ-LD-CD-1	NX5032GA	5 × 3.2	25	30 / 50 ppm	1.3	5.1	7.1	70	500	8	10	10	1.0 ⁽¹⁾	216
												12	12	0.75 ⁽³⁾	269
AURIS	Q-25.000M-HC3225/4-F-30-30-E-12-TR	HC3225/4	3.2 × 2.5	25	30 / 30 ppm	1.58	5.01	8.34	50	500	12	16	16	1	331
FOX	FQ5032B-25	4-SMD	5 × 3.2	25	30 / 30 ppm	1.69	7.92	5.13	50	500	10	14	14	0.5	433
TXC	7A2570018	NX5032GA	5 × 3.2	25	20 / 25 ppm	2.0	6.7	6.1	30	350	10	12	12	2.0 ⁽³⁾	124

(3) R_s values as low as 500 Ω can be used. Using a lower R_s value causes the WC DL to increase toward the maximum DL of the crystal.

5.15.4.6 Main Oscillator Specification With ADC

表 5-14 lists the system clock characteristics with ADC operation.

表 5-14. System Clock Characteristics With ADC Operation

PARAMETER		MIN	NOM	MAX	UNIT
f_{sysadc}	System clock frequency when the ADC module is operating (when PLL is bypassed)		16		MHz

5.15.4.7 System Clock Characteristics With USB Operation

表 5-15 lists the system clock characteristics with USB operation.

表 5-15. System Clock Characteristics With USB Operation

PARAMETER		MIN	NOM	MAX	UNIT
f_{sysusb}	System clock frequency when the USB module is operating (MOSC must be the clock source, either with or without using the PLL)	30			MHz

5.15.5 Sleep Modes

The following tables can be used to calculate the maximum wake time from sleep or deep sleep mode, depending on the specific application. Depending on the application configuration, each parameter, except for t_{FLASH} , adds sequential latency to the wake time. Flash restoration happens in parallel to the other wake processes, and its wake time is normally absorbed by the other latencies. As an example, the wake time for a device in deep sleep mode with the PIOSC and PLL turned off and the flash and SRAM in low-power mode is calculated by 公式 5.

$$\text{Wake Time} = t_{\text{PIOSCDs}} + t_{\text{PLLDS}} + t_{\text{SRAMLpDS}} \quad (5)$$

t_{FLASH} does not contribute to this equation because the values of the other parameters are greater.

In sleep mode, the wake time due to a clock source is zero because the device uses the same clock configuration in run mode; thus, there is no latency involved with respect to the clocks.

表 5-16 lists the wake-up times from sleep mode.

表 5-16. Wake From Sleep Characteristics

over operating free-air temperature (unless otherwise noted)

NO.	PARAMETER		MIN	TYP	MAX	UNIT
D1	t_{PIOSC}	Time to restore PIOSC as system clock in sleep mode			N/A	μs
D2	t_{MOSC}	Time to restore MOSC as system clock in sleep mode			N/A	μs
D3	t_{PLL}	Time to restore PLL as system clock in sleep mode			N/A	μs
D4	t_{LDO}	Time to restore LDO to 1.2 V in sleep mode			39	μs
D5	t_{FLASH}	Time to restore flash to active state from low-power state in sleep mode			96	μs
D6	t_{SRAMLp}	Time to restore SRAM to active state from low-power state in sleep mode			15	μs
D7	t_{SRAMSTBY}	Time to restore SRAM to active state from standby state in sleep mode			15	μs

表 5-16 lists the wake-up times from deep sleep mode.

表 5-17. Wake From Deep Sleep Characteristics

over operating free-air temperature (unless otherwise noted)

NO.	PARAMETER	MIN	TYP	MAX	UNIT
D8	$t_{PIOSCDS}$ Time to restore PIOSC as system clock in deep sleep mode			14	deep-sleep clock cycles
D9	t_{MOSCDS} Time to restore MOSC as system clock in deep sleep mode			18	ms
D10	t_{PLLDS} Time to restore PLL as system clock in deep sleep mode			1 cycle of deep sleep clock + 512 cycles of PLL reference clock ⁽¹⁾	clock cycles
D11	t_{LDODS} Time to restore LDO to 1.2 V in deep sleep mode			39	μ s
D12	$t_{FLASHLPDS}$ Time to restore flash to active state from low-power state			96	μ s
D13	$t_{SRAML PDS}$ Time to restore SRAM to active state from low-power state			15	μ s
D14	$t_{SRAMSTBYDS}$ Time to restore SRAM to active state from standby state			15	μ s

(1) Deep sleep clock can vary. See the *System Control* chapter of the [MSP432E4 SimpleLink™ Microcontrollers Technical Reference Manual](#) for the deep sleep clock options.

5.15.6 Hibernation Module

The Hibernation module requires special system implementation considerations because it is intended to power down all other sections of its host device. See the *Hibernation Module* chapter of the [MSP432E4 SimpleLink™ Microcontrollers Technical Reference Manual](#).

表 5-18 lists the required characteristics of the Hibernation module battery.

表 5-18. Hibernation Module Battery Characteristics

over operating free-air temperature (unless otherwise noted)

PARAMETER		MIN	NOM	MAX	UNIT	
V_{BAT}	Battery supply voltage	1.8	3.0	3.6	V	
V_{BATRMP}	V_{BAT} battery supply voltage ramp time	0		0.7	V/ μ s	
V_{LOWBAT}	Low-battery detect voltage	VBATSEL = 0x0	1.8	1.9	2.0	V
		VBATSEL = 0x1	2.0	2.1	2.2	
		VBATSEL = 0x2	2.2	2.3	2.4	
		VBATSEL = 0x3	2.4	2.5	2.6	

表 5-19 lists the timing characteristics of the HIB module.

表 5-19. Hibernation Module Characteristics

over operating free-air temperature (unless otherwise noted) (see 图 5-13)

NO.	PARAMETER		MIN	TYP	MAX	UNIT
H1	t_{WAKE}	\overline{WAKE} assertion time	100			ns
H2	$t_{WAKE_TO_HIB}$	\overline{WAKE} assert to \overline{HIB} deassert (wake-up time)			1	HIB module clock period
H3	t_{VDD_RAMP}	V_{DD} ramp to 3.0 V		See (1)		μ s
H4	t_{VDD_CODE}	V_{DD} at 3 V to internal POR deassert; first instruction executes			500	μ s
H5	DC _{RTCCLK}	Duty cycle for RTCCLK output signal, when using a 32.768-kHz crystal	40%		60%	
		Duty cycle for RTCCLK output signal, when using a 32.768-kHz external single-ended (bypass) clock source	30%		70%	

(1) Depends on characteristics of power supply.



图 5-13. Hibernation Module Timing

表 5-20 lists the characteristics of the HIB module tamper detection.

表 5-20. Hibernation Module Tamper I/O Characteristics

over operating free-air temperature (unless otherwise noted)

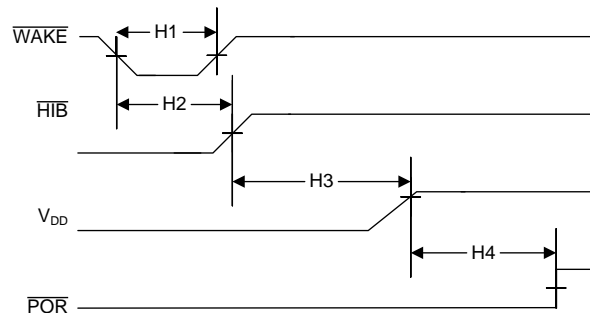
PARAMETER		MIN	TYP	MAX	UNIT
R_{TPU}	TMPRn pullup resistor	3.5	4.4	5.2	M Ω
t_{SP}	TMPRn pulse duration with short glitch filter	62			μ s
t_{LP}	TMPRn pulse duration with long glitch filter	94			ms
t_{NMIS}	TMPRn assertion to NMI (short glitch filter)			95	μ s
t_{NMIL}	TMPRn assertion to NMI (long glitch filter)			94	ms
V_{IH}	TMPRn high-level input voltage when operating from V_{BAT}	V_{BAT} $\times 0.8$			V

5.15.7 Flash Memory

表 5-21 lists the characteristics of the flash memory.

表 5-21. Flash Memory Characteristics

over operating free-air temperature (unless otherwise noted)

PARAMETER		MIN	TYP	MAX	UNIT
PE _{CYC}	Number of program and erase cycles	100000			cycles
t _{RET}	Data retention with 100% power-on hours at T _J = 85°C	20			years
t _{RET_EXTEMP}	Data retention with 10% power-on hours at T _J = 125°C and 90% power-on hours at T _J = 100°C	11			years
t _{PROG64}	Program time for double-word-aligned (64 bits) data	30	100	300	μs
t _{ERASE}	Page erase time	<1k cycles	8	15	ms
		10k cycles	15	40	
		100k cycles	75	500	
t _{ME}	Mass erase time	<1k cycles	10	25	ms
		10k cycles	20	70	
		100k cycles	300	2500	

5.15.8 EEPROM

表 5-22 lists the characteristics of the EEPROM.

表 5-22. EEPROM Characteristics

over operating free-air temperature (unless otherwise noted)

PARAMETER		MIN	TYP	MAX	UNIT
EPE _{CYC}	Number of mass program and erase cycles of a single word	500000			cycles
ET _{RET}	Data retention with 100% power-on hours at T _J = 85°C	20			years
ET _{RET_EXTEMP}	Data retention with 10% power-on hours at T _J = 125°C and 90% power-on hours at T _J = 100°C	11			years
ET _{PROG}	Program time for 32 bits of data with memory space available		110	600	μs
	Program time for 32 bits of data in which a copy to the copy buffer is required, the copy buffer has space, and less than 10% of EEPROM endurance used		30		ms
	Program time for 32 bits of data in which a copy to the copy buffer is required, the copy buffer has space, and more than 90% of EEPROM endurance used			900	
	Program time for 32 bits of data in which a copy of the copy buffer is required, the copy buffer requires an erase, and less than 10% of EEPROM endurance used		60		
	Program time for 32 bits of data a copy to the copy buffer is required, the copy buffer requires an erase, and more than 90% of EEPROM endurance used			1800	
ET _{READ}	Read access time		7 + 2EWS	9 + 4EWS	system clock cycles
ET _{ME}	Mass erase time	<1k cycles	8	15	ms
		10k cycles	15	40	
		100k cycles	75	500	

5.15.9 Input/Output Pin Characteristics

注

All GPIO signals are 3.3-V tolerant, except for PB1 (USB0VBUS) which is 5-V tolerant. See the *General-Purpose Input/Outputs (GPIOs)* chapter of the [MSP432E4 SimpleLink™ Microcontrollers Technical Reference Manual](#) for more information on GPIO configuration.

Two types of pads are provided on the device:

- Fast GPIO pads: These pads provide variable, programmable drive strength and optimized voltage output levels.
 - Slow GPIO pads: These pads provide 2-mA drive strength and are designed to be sensitive to voltage inputs. The following GPIOs port pins are designed with slow GPIO pads:
 - PJ1
-

注

Port pins PL6 and PL7 operate as fast GPIO pads, but have 4-mA drive capability only. GPIO register controls for drive strength, slew rate, and open drain have no effect on these pins. The following registers have no effect: GPIODR2R, GPIODR4R, GPIODR8R, GPIODR12R, GPIOSLR, and GPIOODR.

注

Port pins PM[7:4] operate as fast GPIO pads but support *only* 2-, 4-, 6-, and 8-mA drive capability. All standard GPIO register controls, except for the GPIODR12R register, apply to these port pins.

表 5-23 lists the characteristics of the fast GPIOs.

表 5-23. Fast GPIO Module Characteristics

over operating free-air temperature (unless otherwise noted) ⁽¹⁾ ⁽²⁾ ⁽³⁾ ⁽⁴⁾

PARAMETER		MIN	TYP	MAX	UNIT
C _{LGPIO}	Capacitive loading for measurements given in this table ⁽⁵⁾			50	pF
R _{GPIOPU}	Fast GPIO internal pullup resistor ⁽⁶⁾	12.1	16.0	20.2	kΩ
R _{GPIOPU4MA}	Fast GPIO PL6 and PL7 (4 mA only) pullup resistor	25		40	kΩ
R _{GPIOPD}	Fast GPIO internal pulldown resistor ⁽⁶⁾	13.0	20.5	35.5	kΩ
R _{GPIOPD4MA}	Fast GPIO PL6 and PL7 (4 mA only) pulldown resistor	10	14.3	17	kΩ
I _{LKG+}	Fast GPIO input leakage current, 0 V ≤ V _{IN} ≤ V _{DD} GPIO pins ⁽⁷⁾			400	nA
	Fast GPIO input leakage current, 0 V < V _{IN} ≤ V _{DD} , fast GPIO pins configured as ADC or analog comparator inputs			400	
I _{INJ-}	DC injection current, V _{IN} ≤ 0 V			60	μA
I _{MAXINJ-}	Maximum negative injection if not voltage protected ⁽⁸⁾			-0.5	mA
t _{GPIOR}	Fast GPIO rise time ⁽⁹⁾	2-mA drive	7.85	11.73	ns
		4-mA drive	4.15	6.35	
		8-mA drive	2.33	3.73	
		8-mA drive with slew rate control	3.77	5.76	
		10-mA drive	1.98	3.22	
		12-mA drive	1.75	2.9	
t _{GPIOF}	Fast GPIO fall time ⁽¹⁰⁾	2-mA drive	10.3	16.5	ns
		4-mA drive	5.15	8.29	
		8-mA drive	2.58	4.16	
		8-mA drive with slew rate control	3.54	5.55	
		10-mA drive	2.07	3.34	
		12-mA drive	1.73	2.78	

(1) V_{DD} must be within the range specified in Section 5.4.

(2) Leakage and Injection current characteristics specified in this table also apply to XOSC0 and XOSC1 inputs.

(3) For the external reference inputs of the ADC, avoid a current-limiting resistor (see the I_{VREF} specification in 表 5-33).

(4) I/O pads should be protected if the I/O voltage may go outside the limits shown in the table. If the part is unpowered, the I/O pad voltage or current must be limited (as shown in this table) to avoid powering the part through the I/O pad, which can potentially cause irreversible damage.

(5) See the individual peripheral sections for specific loading information.

(6) This value includes all GPIO except for port pins PL6 and PL7.

(7) The leakage current is measured with V_{IN} applied to the corresponding pins. The leakage of digital port pins is measured individually. The port pin is configured as an input and the pullup/pulldown resistor is disabled.

(8) If the I/O pad is not voltage limited, it should be current limited (to I_{INJ+} + and I_{INJ-}) if there is any possibility of the pad voltage exceeding the V_{IO} limits (including transient behavior during supply ramp up, or at any time when the part is unpowered).

(9) Time measured from 20% to 80% of V_{DD}.

(10) Time measured from 80% to 20% of V_{DD}.

表 5-24 lists the characteristics of the slow GPIOs.

表 5-24. Slow GPIO Module Characteristics

over operating free-air temperature (unless otherwise noted)⁽¹⁾⁽²⁾⁽³⁾

PARAMETER		MIN	TYP	MAX	UNIT
C _{LGPIO}	Capacitive loading for measurements given in this table ⁽⁴⁾			50	pF
R _{GPIOPU}	Slow GPIO internal pullup resistor	13.8	20.0	31.4	kΩ
R _{GPIOPD}	Slow GPIO internal pulldown resistor	13.0	20.5	35.5	kΩ
I _{LKG+}	Slow GPIO input leakage current, 0 V ≤ V _{IN} ≤ V _{DD} , GPIO pins ⁽⁵⁾			3.25	nA
	Slow GPIO input leakage current, 0 V < V _{IN} ≤ V _{DD} , GPIO pins configured as ADC or analog comparator inputs			3.25	
I _{INJ-}	DC injection current, V _{IN} ≤ 0 V			3.42	μA
t _{GPIOR}	Slow GPIO rise time, 2-mA drive ⁽⁶⁾		19.3	29.8	ns
t _{GPIOF}	Slow GPIO fall time, 2-mA drive ⁽⁷⁾		12.8	21.1	ns

(1) V_{DD} must be within the range specified in Section 5.4.

(2) V_{IN} must be within the range specified in Section 5.1. Leakage current outside of this maximum voltage is not ensured and can result in permanent damage of the device.

(3) To avoid potential damage to the part, externally limit either the voltage or current on the I/Os other than power and \overline{WAKE} as listed in this table.

(4) See the individual peripheral sections for specific loading information.

(5) The leakage current is measured with V_{IN} applied to the corresponding pins. The leakage of digital port pins is measured individually. The port pin is configured as an input and the pullup/pulldown resistor is disabled.

(6) Time measured from 20% to 80% of V_{DD}.

(7) Time measured from 80% to 20% of V_{DD}.

5.15.9.1 Types of I/O Pins and ESD Protection

CAUTION

All device I/Os pins, except for PB1, are NOT 5-V tolerant; voltages in excess of the limits in Section 5.4 can permanently damage the device. PB1 is used for the USB0VBUS signal, which requires a 5-V input.

5.15.9.1.1 Hibernate \overline{WAKE} pin

The Hibernate \overline{WAKE} pin uses ESD protection, similar to the one shown in Figure 5-14. This ESD protection prevents a direct path between this pad and any power supply rails in the device. The \overline{WAKE} pad input voltage should be kept inside the maximum ratings specified in Section 5.1 to ensure current leakage and current injections are within acceptable range. Table 5-25 lists current leakages and current injections for these pins.



图 5-14. ESD Protection

表 5-25. Pad Voltage and Current Characteristics for Hibernate \overline{WAKE} Pin

over operating free-air temperature (unless otherwise noted)⁽¹⁾⁽²⁾

PARAMETER	MIN	TYP	MAX	UNIT
I_{LKG+} Positive I/O leakage for $V_{DD} \leq V_{IN} \leq V_{BAT} + 0.3$ V			300	nA
I_{LKG-} Negative I/O leakage for -0.3 V $\leq V_{IN} \leq 0$ V ⁽³⁾			43.3	μ A
I_{INJ+} Maximum positive injection if not voltage protected			2	mA
I_{INJ-} Maximum negative injection if not voltage protected ⁽⁴⁾			-0.5	mA

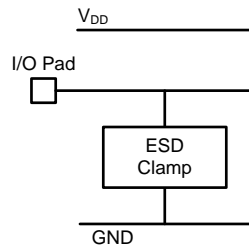
- (1) V_{IN} must be within the range specified in Section 5.1. Leakage current outside of this maximum voltage is not ensured and can result in permanent damage of the device.
- (2) V_{DD} must be within the range specified in Section 5.4.
- (3) Leakage outside the minimum range (-0.3 V) is unbounded and must be limited to I_{INJ-} using an external resistor.
- (4) If the I/O pad is not voltage limited, it should be current limited (to I_{INJ+} and I_{INJ-}) if there is any possibility of the pad voltage exceeding the V_{IO} limits (including transient behavior during supply ramp up, or at any time when the part is unpowered).

5.15.9.1.2 Nonpower I/O Pins

Most nonpower I/Os (with the exception of the I/O pad for Hibernate $\overline{\text{WAKE}}$ input) have ESD protection as shown in 图 5-15.

These I/Os have an ESD clamp to ground and a diode connection to the corresponding power supply rail. To prevent potential damage to the device, follow the specifications in 表 5-26 for the voltage and current of these I/Os. In addition, comply with that the ADC external reference specifications in 表 5-33 to prevent gain error.



图 5-15. ESD Protection for Nonpower Pins (Except $\overline{\text{WAKE}}$ Signal)

表 5-26. Nonpower I/O Pad Voltage and Current Characteristics

over operating free-air temperature (unless otherwise noted) ⁽¹⁾ ⁽²⁾ ⁽³⁾

PARAMETER		MIN	TYP	MAX	UNIT
V_{IO}	I/O pad voltage limits if voltage protected	-0.3	V_{DD}	$V_{DD} + 0.3$	V
I_{LKG+}	Positive I/O leakage for $V_{DD} \leq V_{IN} \leq V_{IO}$ ⁽⁴⁾			400	nA
I_{LKG-}	Negative I/O leakage for $V_{IO} \text{ MIN} \leq V_{IN} \leq 0V$ ⁽⁴⁾			60	μA
I_{INJ+}	Maximum positive injection if not voltage protected ⁽⁵⁾			2	mA
I_{INJ-}	Maximum negative injection if not voltage protected ⁽⁵⁾			-0.5	mA

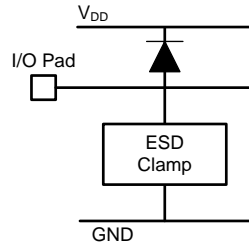
- (1) To avoid potential damage to the part, externally limit either the voltage or current on I/Os other than power and $\overline{\text{WAKE}}$ as listed in this table.
- (2) For the external reference inputs of the ADC, avoid a current-limiting resistor (see the I_{VREF} specification in 表 5-33).
- (3) I/O pads should be protected if at any point the I/O voltage has a possibility of going outside the limits shown in the table. If the part is unpowered, the I/O pad voltage and current must be limited (as shown in this table) to avoid powering the part through the I/O pad, which can potentially cause irreversible damage.
- (4) MIN and MAX leakage current for the case when the I/O is voltage protected to $V_{IO} \text{ MIN}$ or $V_{IO} \text{ MAX}$.
- (5) If the I/O pad is not voltage limited, it should be current limited (to I_{INJ+} and I_{INJ-}) if there is any possibility of the pad voltage exceeding the V_{IO} limits (including transient behavior during supply ramp up, or at any time when the part is unpowered).

5.15.10 External Peripheral Interface (EPI)

表 5-27 lists the load conditions used to characterize the EPI interface.

表 5-27. EPI Interface Load Conditions

SIGNALS	LOAD VALUE (C _L)
EPIOS[35:0] SDRAM interface	30 pF
EPIOS[35:0] General-Purpose interface	
EPIOS[35:0] Host-Bus interface	
EPIOS[35:0] PSRAM interface	40 pF

When the EPI module is in SDRAM mode, EPI CLK (EPI0S31) must be configured to 12 mA. The EPI data bus can be configured to 8 mA. 表 5-28 lists the rise and fall times in SDRAM mode.

表 5-28. EPI SDRAM Characteristics

over operating free-air temperature (unless otherwise noted)

PARAMETER	TEST CONDITIONS	MIN	TYP	MAX	UNIT
t _{SDRAMR} EPI rise time (from 20% to 80% of V _{DD})	12-mA drive, C _L = 30 pF		2	3	ns
t _{SDRAMF} EPI fall time (from 80% to 20% of V _{DD})	12-mA drive, C _L = 30 pF		2	3	ns

表 5-29 lists the switching characteristics of the SDRAM interface.

表 5-29. EPI SDRAM Interface Characteristics

over operating free-air temperature (unless otherwise noted) ⁽¹⁾ (see 图 5-16, 图 5-17, and 图 5-18)

NO.	PARAMETER	MIN	TYP	MAX	UNIT
E1	t _{CK} SDRAM clock period	16.67			ns
E2	t _{CH} SDRAM clock high time	8.33			ns
E3	t _{CL} SDRAM clock low time	8.33			ns
E4	t _{COV} CLK to output valid			4	ns
E5	t _{COI} CLK to output invalid			4	ns
E6	t _{COT} CLK to output tristate			4	ns
E7	t _S Input set up to CLK	8.5			ns
E8	t _H CLK to input hold	0			ns
E9	t _{PU} Power-up time	100			μs
E10	t _{RP} Precharge all banks	20			ns
E11	t _{RFC} Auto refresh	66			ns
E12	t _{MRD} Program mode register	2			EPI CLK

(1) The EPI SDRAM interface must use 12-mA drive.

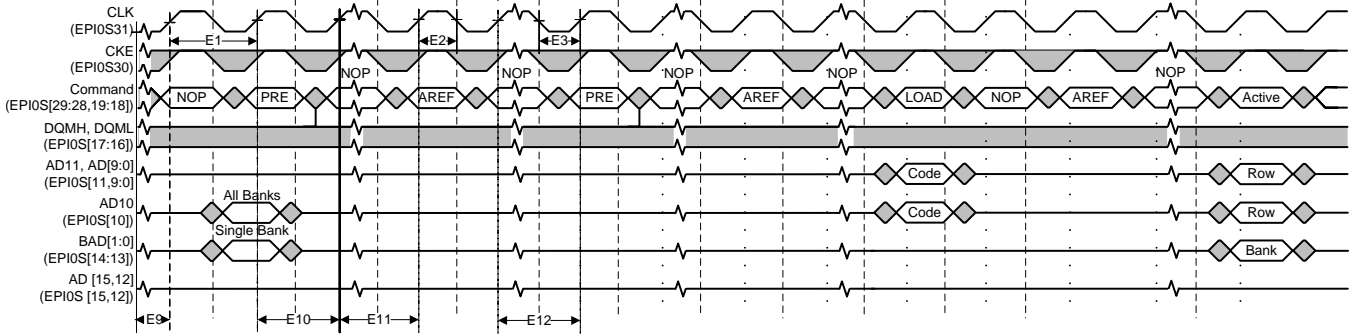

- (1) If CS is high at clock high time, all applied commands are NOP.
- (2) The Mode register can be loaded before the autorefresh cycles.
- (3) JEDEC and PC100 specify 3 clock cycles.
- (4) Outputs are Hi-Z after the command is issued.

图 5-16. SDRAM Initialization and Load Mode Register Timing



图 5-17. SDRAM Read Timing



图 5-18. SDRAM Write Timing

表 5-30 lists the characteristics of the Host-Bus 8 and Host-Bus 16 interface.

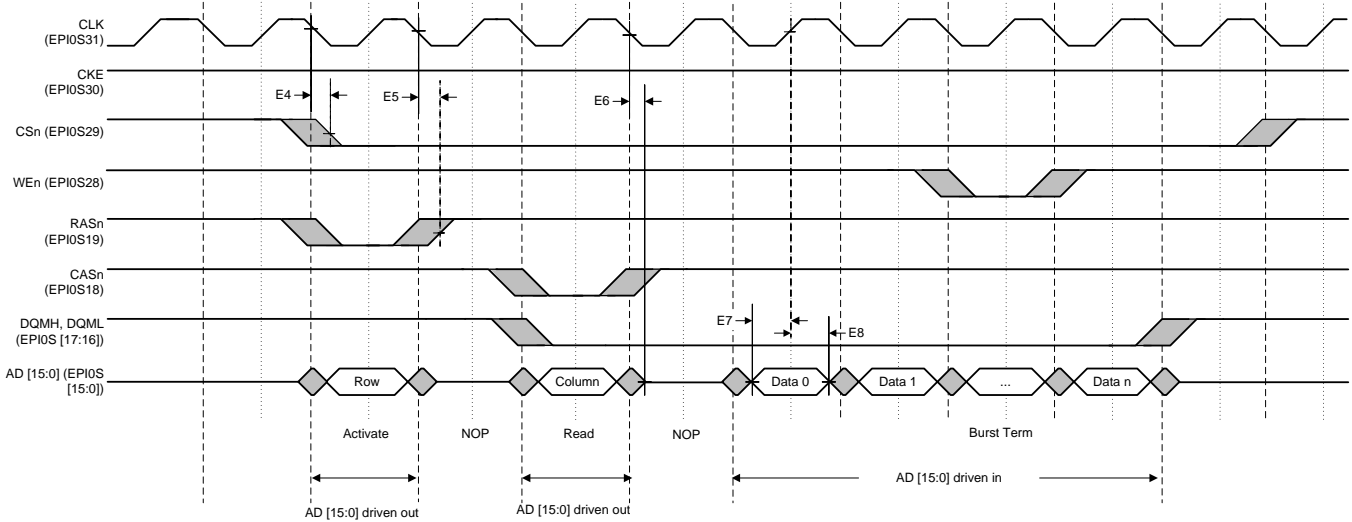
表 5-30. EPI Host-Bus 8 and Host-Bus 16 Interface Characteristics

over operating free-air temperature (unless otherwise noted) (see 图 5-19, 图 5-20, 图 5-21, and 图 5-22)

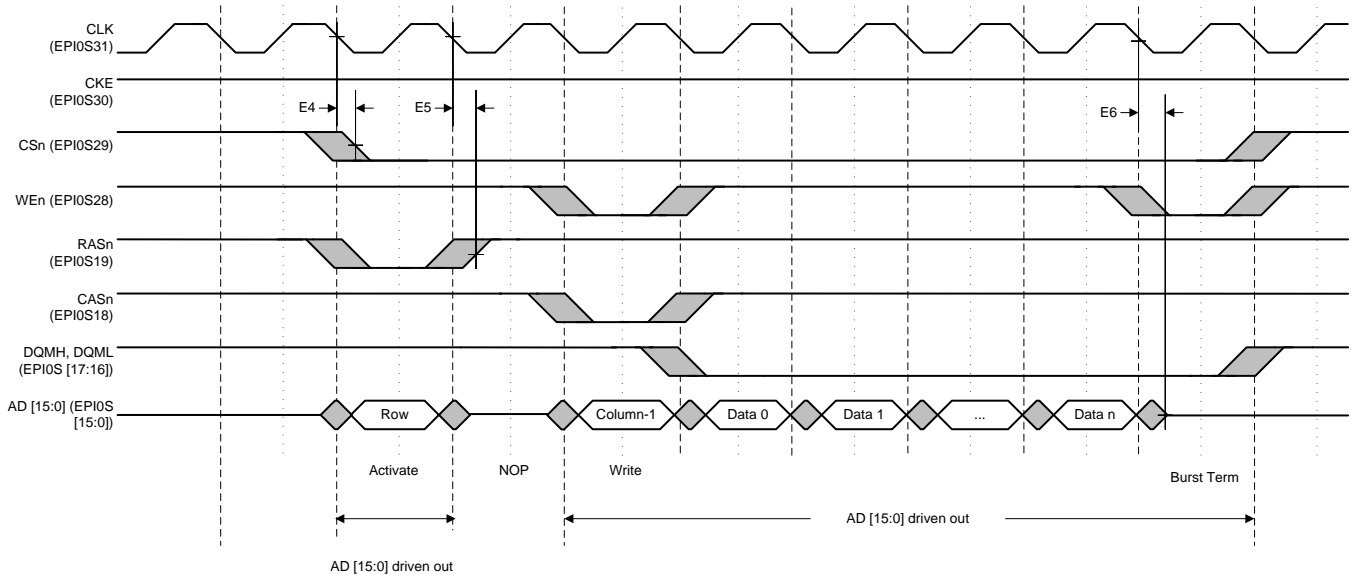
NO.	PARAMETER		MIN	TYP	MAX	UNIT
E14	t_{SU}	Read data set up time	10			ns
E15	t_{H}	Read data hold time	0			ns
E16	t_{DV}	WRn to write data valid			3.6	ns
E17	t_{DI}	Data hold from WRn invalid	1			EPI clock cycles
E18	t_{OV}	ALE/CSn to output valid			4	ns
E19	t_{OINV}	CSn to output invalid			4	ns
E20	t_{STLOW}	WRn / RDn strobe duration low	1			EPI clock cycles
E21	t_{ALEHIGH}	ALE duration high		1		EPI clock cycles
E22	t_{CSLOW}	CSn duration low	2			EPI clock cycles
E23	t_{ALEST}	ALE rising to WRn / RDn strobe falling	2			EPI clock cycles
E24	t_{ALEADD}	ALE falling to Address high impedance	1			EPI clock cycles

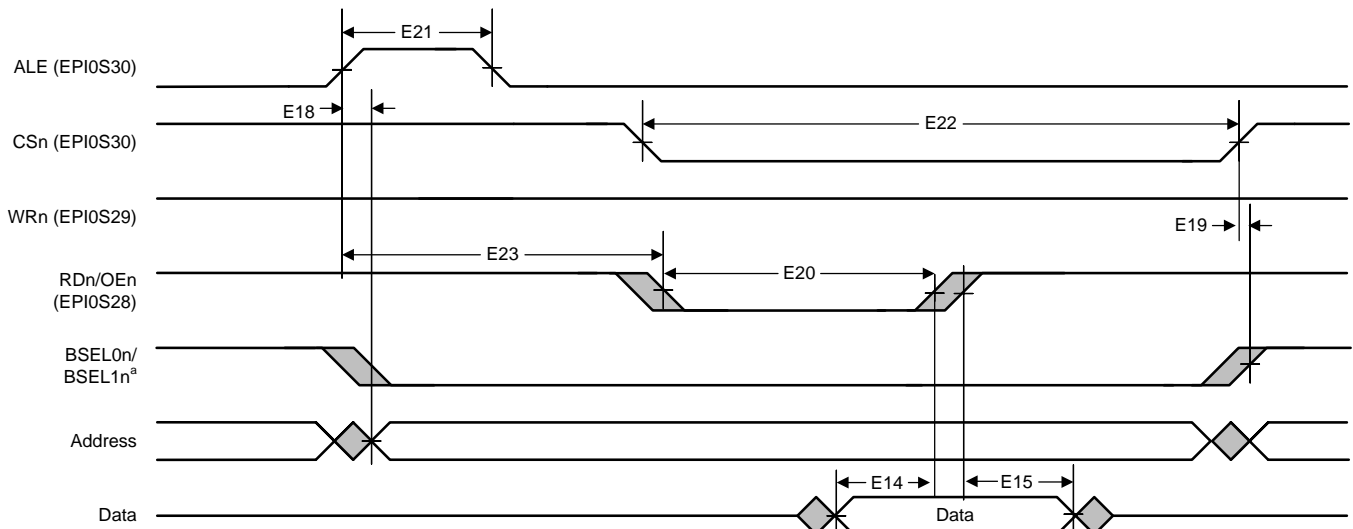

^a BSEL0n and BSEL1n are available in Host-Bus 16 mode only.

图 5-19. Host-Bus 8/16 Asynchronous Mode Read Timing

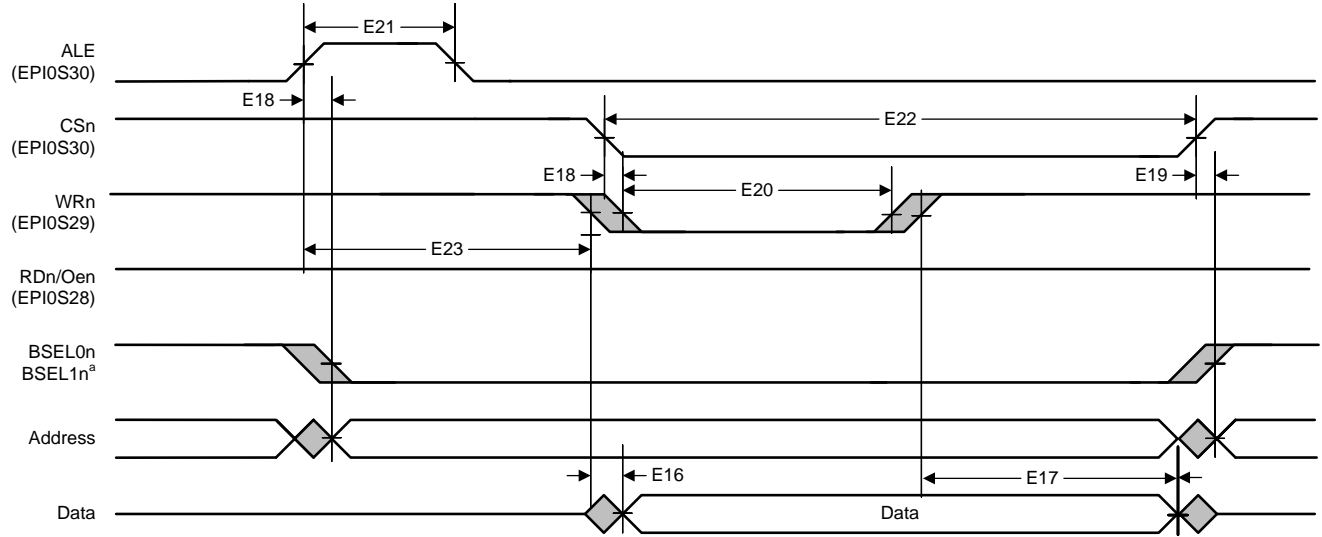

^a BSEL0n and BSEL1n are available in Host-Bus 16 mode only.

图 5-20. Host-Bus 8/16 Asynchronous Mode Write Timing

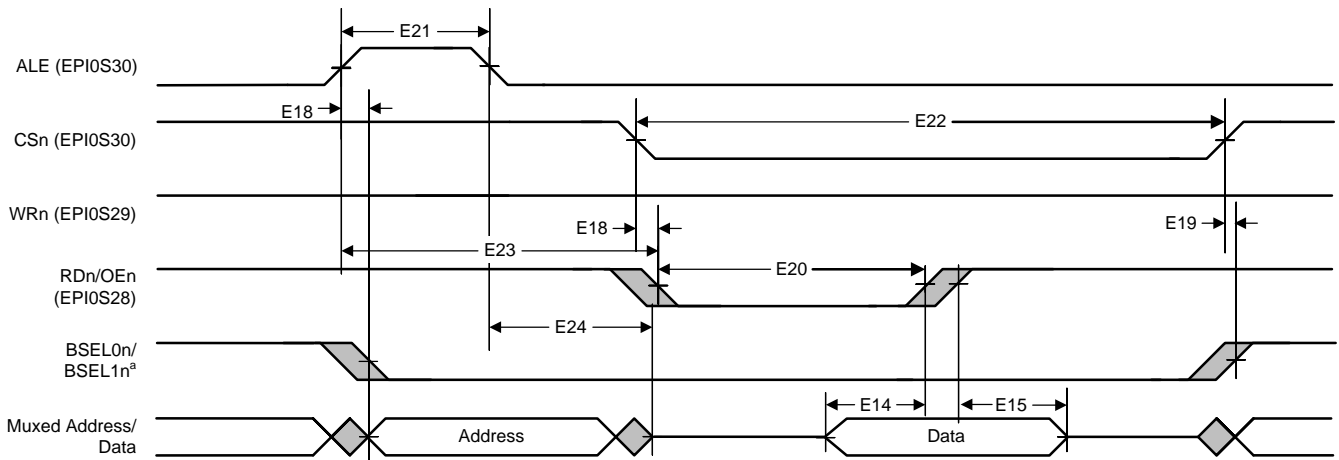

^a BSEL0n and BSEL1n are available in Host-Bus 16 mode only.

图 5-21. Host-Bus 8/16 Mode Asynchronous Muxed Read Timing

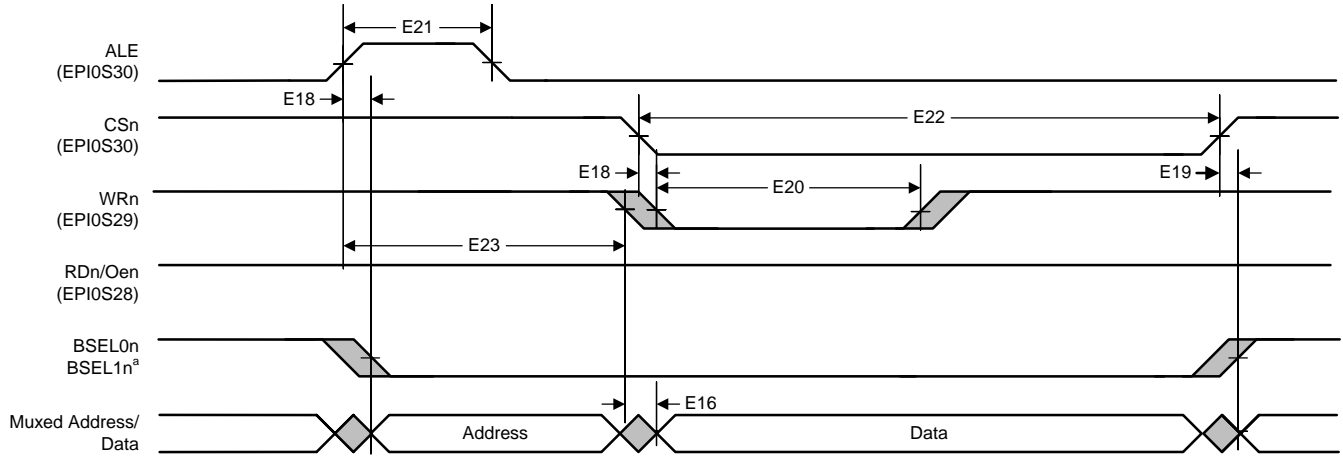

^a BSEL0n and BSEL1n are available in Host-Bus 16 mode only.

图 5-22. Host-Bus 8/16 Mode Asynchronous Muxed Write Timing

表 5-31 lists the switching characteristics of the general-purpose interface.

表 5-31. EPI General-Purpose Interface Characteristics

over operating free-air temperature (unless otherwise noted) (see 图 5-23)

NO.	PARAMETER		MIN	TYP	MAX	UNIT
E25	t_{CK}	General-purpose clock period	16.67			ns
E26	t_{CH}	General-purpose clock high time	8.33			ns
E27	t_{CL}	General-purpose clock low time	8.33			ns
E28	t_{ISU}	Input signal set up time to rising clock edge	8.50			ns
E29	t_{IH}	Input signal hold time from rising clock edge	0			ns
E30	t_{DV}	Falling clock edge to output valid			4	ns
E31	t_{DI}	Falling clock edge to output invalid			4	ns

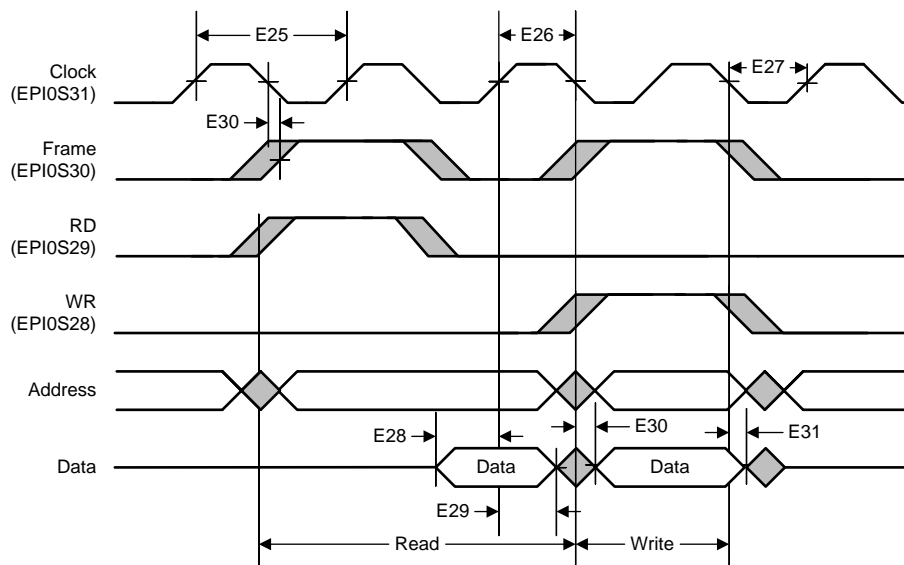

NOTE: This figure shows accesses when the FRM50 bit is clear, the FRMCNT field is 0x0, and the WR2CYC bit is clear.

图 5-23. General-Purpose Mode Read and Write Timing

表 5-32 lists the switching characteristics of the PSRAM interface.

表 5-32. EPI PSRAM Interface Characteristics

over operating free-air temperature (unless otherwise noted) (see 图 5-24 and 图 5-25)

NO.	PARAMETER		MIN	TYP	MAX	UNIT
E33	t_{EPICLK}	EPI_CLK period	20			ns
E34	t_{RTFT}	EPI_CLK rise or fall time			1.8	ns
E35	t_{OV}	Falling EPI_CLK to address/write data or control output valid ⁽¹⁾	4.5		20	ns
E36	t_{HT}	Falling EPI_CLK to address/write data or control hold time ⁽¹⁾	2			ns
E37	t_{SUP}	Read data setup time from EPI_CLK rising			9	ns
E38	t_{DH}	Read data output hold from EPI_CLK rising	0			ns
E39	t_{IRV}	iRDY setup time			9	ns
E40	t_{IRH}	iRDY hold time			9	ns

(1) Control output includes WRn, RDn, OEn, BSELn, ALE, and CSn.



图 5-24. PSRAM Single Burst Read



图 5-25. PSRAM Single Burst Write

5.15.11 Analog-to-Digital Converter (ADC)

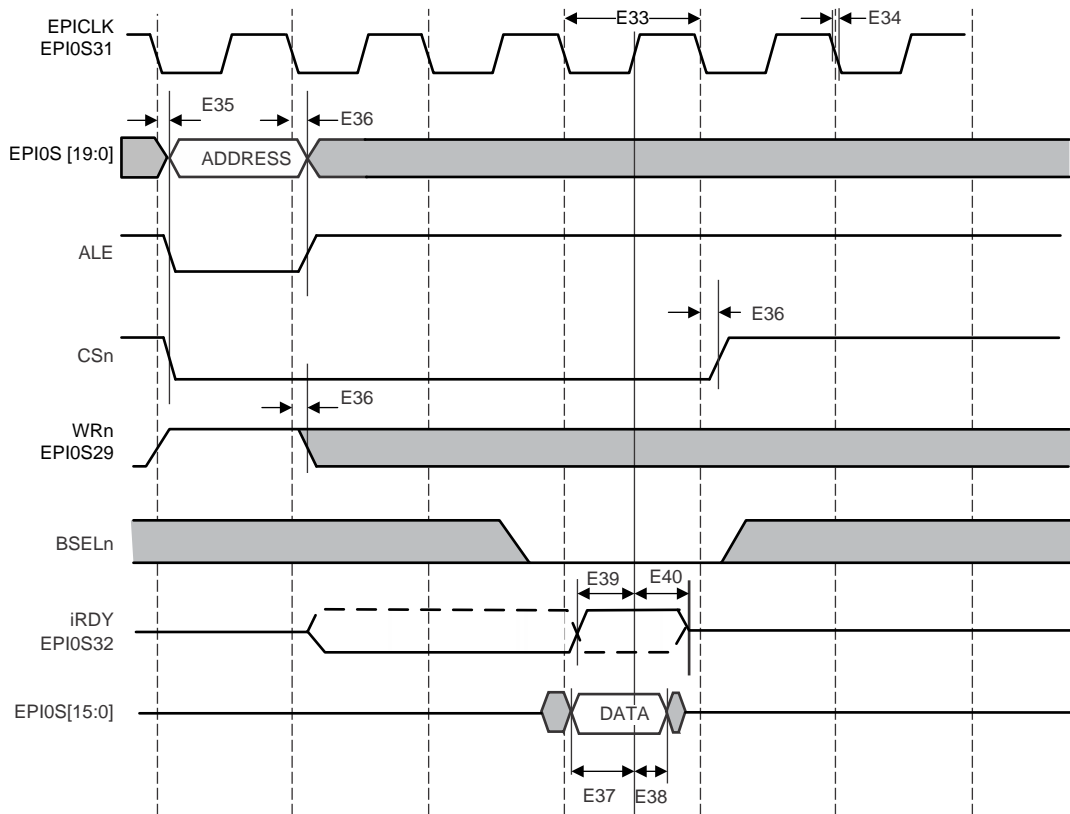
表 5-33 lists the electrical characteristics for the ADC at 1 Msps.

表 5-33. Electrical Characteristics for ADC at 1 Msps

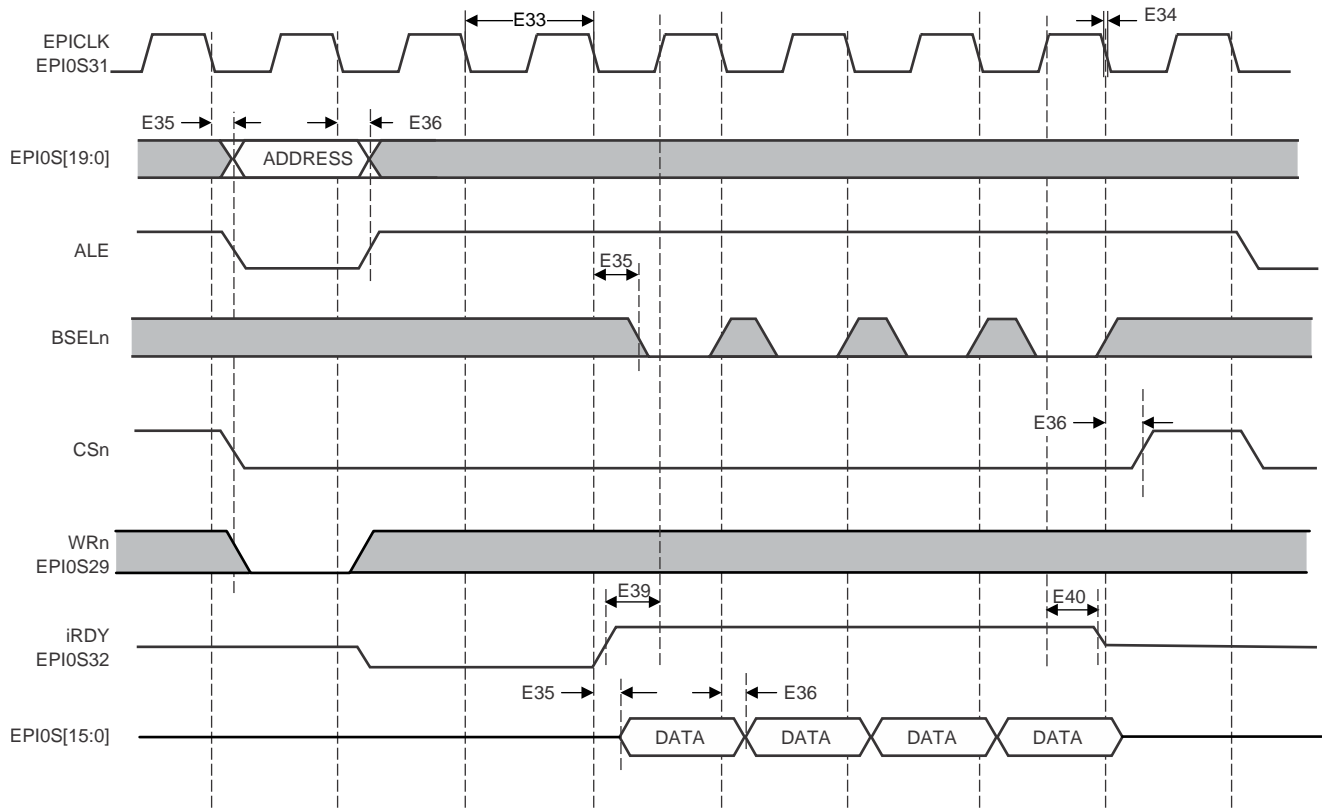
$V_{REF+} = 3.3\text{ V}$, $f_{ADC} = 16\text{ MHz}$ (unless otherwise noted)⁽¹⁾

PARAMETER		MIN	TYP	MAX	UNIT
Power supply requirements					
V_{DDA}	ADC supply voltage	2.97	3.3	3.63	V
G_{NDA}	ADC ground voltage		0		V
VDDA and GND A voltage reference					
C_{REF}	Voltage reference decoupling capacitance		1.0 // 0.01 ⁽²⁾		μF
External voltage reference input					
V_{REFA+}	Positive external voltage reference for ADC, when VREF field in the ADCCTL register is 0x1 ⁽³⁾	2.4	V_{DDA}	V_{DDA}	V
V_{REFA-}	Negative external voltage reference for ADC, when VREF field in the ADCCTL register is 0x1 ⁽³⁾	G_{NDA}	G_{NDA}	0.3	V
I_{VREF}	Current on VREF+ input, using external $V_{REF+} = 3.3\text{ V}$		330.5	440	μA
I_{LVREF}	DC leakage current on VREF+ input when external VREF disabled			2.0	μA
C_{REF}	External reference decoupling capacitance ⁽³⁾		1.0 // 0.01 ⁽²⁾		μF
Analog input					
V_{ADCIN}	Single-ended, full-scale analog input voltage, internal reference ⁽⁴⁾⁽⁵⁾	0		V_{DDA}	V
	Differential, full-scale analog input voltage, internal reference ⁽⁴⁾⁽⁶⁾	$-V_{DDA}$		V_{DDA}	
	Single-ended, full-scale analog input voltage, external reference ⁽³⁾⁽⁵⁾	V_{REFA-}		V_{REFA+}	
	Differential, full-scale analog input voltage, external reference ⁽³⁾⁽⁷⁾	$-(V_{REFA+} - V_{REFA-})$		$V_{REFA+} - V_{REFA-}$	
V_{INCM}	Input common-mode voltage, differential mode ⁽⁸⁾			$[(V_{REFA+} + V_{REFA-}) / 2] \pm 0.025$	V
I_L	ADC input leakage current ⁽⁹⁾			2.0	μA
R_{ADC}	ADC equivalent input resistance ⁽⁹⁾			2.5	$\text{k}\Omega$
C_{ADC}	ADC equivalent input capacitance ⁽⁹⁾			10	pF
R_S	Analog source resistance ⁽⁹⁾			500	Ω
Sampling dynamics					
f_{ADC}	ADC conversion clock frequency ⁽¹⁰⁾		16		MHz
f_{CONV}	ADC conversion rate		1		Msps
t_S	ADC sample time		250		ns
t_C	ADC conversion time ⁽¹¹⁾		1		μs

- (1) Best design practices suggest placing static or quiet digital I/O signals adjacent to sensitive analog inputs to reduce capacitive coupling and crosstalk. Unexpected results can occur if a switching digital I/O is placed adjacent to an ADC input channel or voltage reference input. In addition, analog signals that are adjacent to ADC input channels or reference inputs must meet the R_{ADC} equivalent input resistance given in this table and must be band-limited to 100 kHz or lower.
- (2) Two capacitors in parallel. These capacitors should be as close to the die as possible.
- (3) Assumes external filtering network between V_{REFA+} and V_{REFA-} as shown in 图 5-26. External reference noise level must be under 12-bit (-74 dB) full-scale input, over input bandwidth, measured at $V_{REFA+} - V_{REFA-}$.
- (4) Internal reference is connected directly between V_{DDA} and G_{NDA} ($V_{REFi} = V_{DDA} - G_{NDA}$). In this mode, E_O , E_G , E_T , and dynamic specifications are adversely affected due to internal voltage drop and noise on V_{DDA} and G_{NDA} . Internal reference voltage is selected when VREF field in the ADCCTL register is 0x0.
- (5) $V_{ADCIN} = V_{INP} - V_{INN}$
- (6) With signal common-mode voltage as $V_{DDA} / 2$.
- (7) With signal common-mode voltage as $V_{REF+} + G_{NDA}$.
- (8) This parameter is defined as the average of the differential inputs.
- (9) As shown in 图 5-27, R_{ADC} is the total equivalent resistance in the input line all the way up to the sampling node at the input of the ADC.
- (10) See 表 5-14 for full ADC clock frequency specification.
- (11) ADC conversion time (t_C) includes the ADC sample time (t_S).

表 5-33. Electrical Characteristics for ADC at 1 Msps (continued)
 $V_{REF+} = 3.3\text{ V}$, $f_{ADC} = 16\text{ MHz}$ (unless otherwise noted)⁽¹⁾

PARAMETER		MIN	TYP	MAX	UNIT
t_{LT}	Latency from trigger to start of conversion		2		ADC clock cycles
System performance when using external reference ^{(12) (13)}					
N	Resolution		12		bits
INL	Integral nonlinearity error, over full input range		±1.5	±3.0	LSB
DNL	Differential nonlinearity error, over full input range		±0.8	+2.0/-1.0 ⁽¹⁴⁾	LSB
E_O	Offset error		±1.0	±3.0	LSB
E_G	Gain error ⁽¹⁵⁾		±2.0	±3.0	LSB
E_T	Total unadjusted error, over full input range ⁽¹⁶⁾		±2.5	±4.0	LSB
System performance when using internal reference					
N	Resolution		12		bits
INL	Integral nonlinearity error, over full input range		±1.5	±3.0	LSB
DNL	Differential nonlinearity error, over full input range		±0.8	+2.0/-1.0 ⁽¹⁴⁾	LSB
E_O	Offset error		±5.0	±15.0	LSB
E_G	Gain error ⁽¹⁵⁾		±10.0	±30.0	LSB
E_T	Total unadjusted error, over full input range ⁽¹⁶⁾		±10.0	±30.0	LSB
Dynamic characteristics ^{(12) (17)}					
SNR_D	Signal-to-noise-ratio, Differential input, V_{ADCIN} : -20 dB FS, 1 kHz ⁽¹⁸⁾	70	72		dB
SDR_D	Signal-to-distortion ratio, Differential input, V_{ADCIN} : -3 dB FS, 1 kHz ^{(18) (19) (20)}	72	75		dB
$SNDR_D$	Signal-to-Noise+Distortion ratio, Differential input, V_{ADCIN} : -3 dB FS, 1 kHz ^{(18) (21) (22)}	68	70		dB
SNR_S	Signal-to-noise-ratio, Single-ended input, V_{ADCIN} : -20 dB FS, 1 kHz ⁽²³⁾	60	65		dB
SDR_S	Signal-to-distortion ratio, Single-ended input, V_{ADCIN} : -3 dB FS, 1 kHz ^{(19) (20)}	70	72		dB
$SNDR_S$	Signal-to-Noise+Distortion ratio, Single-ended input, V_{ADCIN} : -3 dB FS, 1 kHz ^{(23) (21) (22)}	60	63		dB
Temperature sensor					
V_{TSENS}	Temperature sensor voltage, junction temperature 25°C		1.633		V
S_{TSENS}	Temperature sensor slope at: -40°C to 105°C ambient (extended temperature part)		-13.3		mV/°C

(12) A low-noise environment is assumed to obtain values close to specifications. The board must have good ground isolation between analog and digital grounds and a clean reference voltage. The input signal must be band-limited to Nyquist bandwidth. No antialiasing filter is provided internally.

(13) ADC static measurements taken by averaging over several samples. At least 20-sample averaging is assumed to obtain expected typical or maximum specification values.

(14) 12-bit DNL

(15) Gain error is measured at maximum code after compensating for offset. Gain error is equivalent to the full-scale error. It can be given in % of slope error, or in LSB, as done here.

(16) Total unadjusted error is the maximum error at any one code versus the ideal ADC curve. It includes all other errors (offset error, gain error and INL) at any given ADC code.

(17) ADC dynamic characteristics are measured using low-noise board design, with low-noise reference voltage (< -74-dB noise level in signal bandwidth) and low-noise analog supply voltage. Board noise and ground bouncing couple into the ADC and affect dynamic characteristics. A clean external reference must be used to achieve the listed specifications.

(18) Differential signal with correct common-mode voltage, applied between two ADC inputs.

(19) $SDR = -THD$ in dB.

(20) For higher-frequency inputs, expect degradation in SDR.

(21) $SNDR = S/(N+D) = SINAD$ (in dB)

(22) Effective number of bits (ENOB) can be calculated from SNDR: $ENOB = (SNDR - 1.76) / 6.02$.

(23) Single-ended inputs are more sensitive to board and trace noise than differential inputs; SNR and SNDR measurements on single-ended inputs are highly dependent on how clean the test setup is. If the input signal is not well isolated on the board, higher noise than specified could be seen at the ADC output.

表 5-33. Electrical Characteristics for ADC at 1 Msps (continued)

 $V_{REF+} = 3.3\text{ V}$, $f_{ADC} = 16\text{ MHz}$ (unless otherwise noted)⁽¹⁾

PARAMETER		MIN	TYP	MAX	UNIT
E_{TSENS}	Temperature sensor accuracy ⁽²⁴⁾ at: –40°C to 105°C ambient (extended temperature part)			±5	°C

(24) This parameter does not include ADC error.

表 5-34 lists the electrical characteristics for the ADC at 2 Msps.

表 5-34. Electrical Characteristics for ADC at 2 Msps

$V_{REF+} = 3.3\text{ V}$, $f_{ADC} = 32\text{ MHz}$, over operating free-air temperature (unless otherwise noted) (see 图 5-26 and 图 5-27)⁽¹⁾

PARAMETER		MIN	TYP	MAX	UNIT
Power supply requirements					
V_{DDA}	ADC supply voltage	2.97	3.3	3.63	V
G_{NDA}	ADC ground voltage		0		V
VDDA and GNDA voltage reference					
C_{REF}	Voltage reference decoupling capacitance	1.0 // 0.01 ⁽²⁾			μF
External voltage reference input					
V_{REFA+}	Positive external voltage reference for ADC, when VREF field in the ADCCTL register is 0x1 ⁽³⁾	2.4	V_{DDA}	V_{DDA}	V
V_{REFA-}	Negative external voltage reference for ADC, when VREF field in the ADCCTL register is 0x1 ⁽³⁾	G_{NDA}	G_{NDA}	0.3	V
I_{VREF}	Current on VREF+ input, using external $V_{REF+} = 3.3\text{ V}$		330.5	440	μA
I_{LVREF}	DC leakage current on VREF+ input when external VREF disabled			2.0	μA
C_{REF}	External reference decoupling capacitance ⁽³⁾	1.0 // 0.01 ⁽²⁾			μF
Analog input					
V_{ADCIN}	Single-ended, full-scale analog input voltage, internal reference ⁽⁴⁾⁽⁵⁾	0		V_{DDA}	V
	Differential, full-scale analog input voltage, internal reference ⁽⁴⁾⁽⁶⁾	$-V_{DDA}$		V_{DDA}	
	Single-ended, full-scale analog input voltage, external reference ⁽³⁾ ⁽⁵⁾	V_{REFA-}		V_{REFA+}	
	Differential, full-scale analog input voltage, external reference ⁽³⁾⁽⁷⁾	$-(V_{REFA+} - V_{REFA-})$		$V_{REFA+} - V_{REFA-}$	
V_{INCM}	Input common-mode voltage, differential mode ⁽⁸⁾			$[(V_{REFA+} + V_{REFA-}) / 2] \pm 0.025$	V
I_L	ADC input leakage current ⁽⁹⁾			2.0	μA
R_{ADC}	ADC equivalent input resistance ⁽⁹⁾			2.5	$\text{k}\Omega$
C_{ADC}	ADC equivalent input capacitance ⁽⁹⁾			10	pF
R_S	Analog source resistance ⁽⁹⁾			250	Ω
Sampling dynamics					
f_{ADC}	ADC conversion clock frequency ⁽¹⁰⁾		32		MHz
f_{CONV}	ADC conversion rate			2	Msps
t_S	ADC sample time		125		ns
t_C	ADC conversion time ⁽¹¹⁾		0.5		μs
t_{LT}	Latency from trigger to start of conversion		2		ADC clock cycles

- (1) Best design practices suggest placing static or quiet digital I/O signals adjacent to sensitive analog inputs to reduce capacitive coupling and crosstalk. Unexpected results can occur if a switching digital I/O is placed adjacent to an ADC input channel or voltage reference input. In addition, analog signals configured adjacent to ADC input channels or reference inputs must meet the R_{ADC} equivalent input resistance given in this table and must be band-limited to 100 kHz or lower.
- (2) Two capacitors in parallel. These capacitors should be as close to the die as possible.
- (3) Assumes external filtering network between V_{REFA+} and V_{REFA-} as shown in 图 5-26. External reference noise level must be under 12-bit (-74-dB) full scale input, over input bandwidth, measured at $V_{REFA+} - V_{REFA-}$.
- (4) Internal reference is connected directly between V_{DDA} and V_{GNDA} ($V_{REFI} = V_{DDA} - V_{GNDA}$). In this mode, E_O , E_G , E_T , and dynamic specifications are adversely affected due to internal voltage drop and noise on V_{DDA} and G_{NDA} . Internal reference voltage is selected when VREF field in the ADCCTL register is 0x0.
- (5) $V_{ADCIN} = V_{INP} - V_{INN}$
- (6) With signal common-mode voltage as $V_{DDA} / 2$.
- (7) With signal common-mode voltage as $(V_{REF+} + V_{REF-}) / 2$.
- (8) This parameter is defined as the average of the differential inputs.
- (9) As shown in 图 5-27, R_{ADC} is the total equivalent resistance in the input line all the way up to the sampling node at the input of the ADC.
- (10) See 表 5-14 for full ADC clock frequency specification.
- (11) ADC conversion time (t_C) includes the ADC sample time (t_S).

表 5-34. Electrical Characteristics for ADC at 2 Msps (continued)

 $V_{REF+} = 3.3\text{ V}$, $f_{ADC} = 32\text{ MHz}$, over operating free-air temperature (unless otherwise noted) (see 图 5-26 and 图 5-27)⁽¹⁾

PARAMETER		MIN	TYP	MAX	UNIT
System performance when using external reference ^{(12) (13)}					
N	Resolution		12		bits
INL	Integral nonlinearity error, over full input range		±1.5	±3.0	LSB
DNL	Differential nonlinearity error, over full input range		±0.8	+2.0/–1.0 ⁽¹⁴⁾	LSB
E _O	Offset error		±1.0	±3.0	LSB
E _G	Gain error ⁽¹⁵⁾		±2.0	±3.0	LSB
E _T	Total unadjusted error, over full input range ⁽¹⁶⁾		±2.5	±4.0	LSB
System performance when using internal reference					
N	Resolution		12		bits
INL	Integral nonlinearity error, over full input range		±1.5	±3.0	LSB
DNL	Differential nonlinearity error, over full input range		±0.8	+2.0/–1.0 ⁽¹⁴⁾	LSB
E _O	Offset error		±5.0	±15.0	LSB
E _G	Gain error ⁽¹⁵⁾		±10.0	±30.0	LSB
E _T	Total unadjusted error, over full input range ⁽¹⁶⁾		±10.0	±30.0	LSB
Dynamic characteristics ^{(17) (18)}					
SNR _D	Signal-to-noise-ratio, differential input, V _{ADCIN} : –20 dB FS, 1 kHz ⁽¹⁹⁾	68	72		dB
SDR _D	Signal-to-distortion ratio, differential input, V _{ADCIN} : –3 dB FS, 1 kHz ^{(19) (20) (21)}	70	75		dB
SNDR _D	Signal-to-noise+distortion ratio, differential input, V _{ADCIN} : –3 dB FS, 1 kHz ^{(19) (22) (23)}	65	70		dB
SNR _S	Signal-to-noise-ratio, single-ended input, V _{ADCIN} : –20 dB FS, 1 kHz ⁽²⁴⁾	58	65		dB
SDR _S	Signal-to-distortion ratio, single-ended input, V _{ADCIN} : –3 dB FS, 1 kHz ^{(20) (21)}	68	72		dB
SNDR _S	Signal-to-noise+distortion ratio, single-ended input, V _{ADCIN} : –3 dB FS, 1 kHz ^{(24) (22) (23)}	58	63		dB

(12) A low-noise environment is assumed to obtain values close to specifications. The board must have good ground isolation between analog and digital grounds, a clean reference voltage is assumed, and input signal must be bandlimited to Nyquist bandwidth. No antialiasing filter is provided internally.

(13) ADC static measurements taken by averaging over several samples. At least 20-sample averaging is assumed to obtain expected typical or maximum specification values.

(14) 12-bit DNL

(15) Gain error is measured at maximum code after compensating for offset. Gain error is equivalent to "Full Scale Error." It can be given in % of slope error, or in LSB, as done here.

(16) Total Unadjusted Error is the maximum error at any one code versus the ideal ADC curve. It includes all other errors (offset error, gain error and INL) at any given ADC code.

(17) A low noise environment is assumed to obtain values close to spec. The board must have good ground isolation between analog and digital grounds and a clean reference voltage. The input signal must be band-limited to Nyquist bandwidth. No antialiasing filter is provided internally.

(18) ADC dynamic characteristics are measured using low-noise board design, with low-noise reference voltage (< –74 dB noise level in signal BW) and low-noise analog supply voltage. Board noise and ground bouncing couple into the ADC and affect dynamic characteristics. Clean external reference must be used to achieve the listed specifications.

(19) Differential signal with correct common-mode voltage, applied between two ADC inputs.

(20) SDR = –THD in dB.

(21) For higher-frequency inputs, expect degradation in SDR.

(22) SNDR = S/(N+D) = SINAD (in dB)

(23) Effective number of bits (ENOB) can be calculated from SNDR: ENOB = (SNDR – 1.76) / 6.02.

(24) Single-ended inputs are more sensitive to board and trace noise than differential inputs; SNR and SNDR measurements on single-ended inputs are highly dependent on how clean the test setup is. If the input signal is not well isolated on the board, higher noise than specified could be seen at the ADC output.

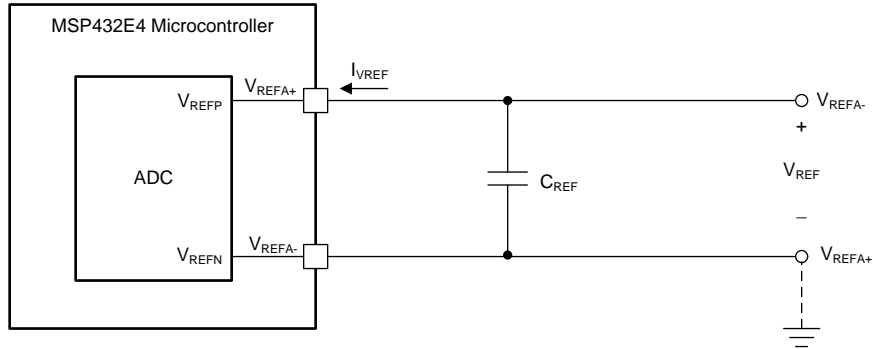

Copyright © 2017, Texas Instruments Incorporated

图 5-26. ADC External Reference Filtering

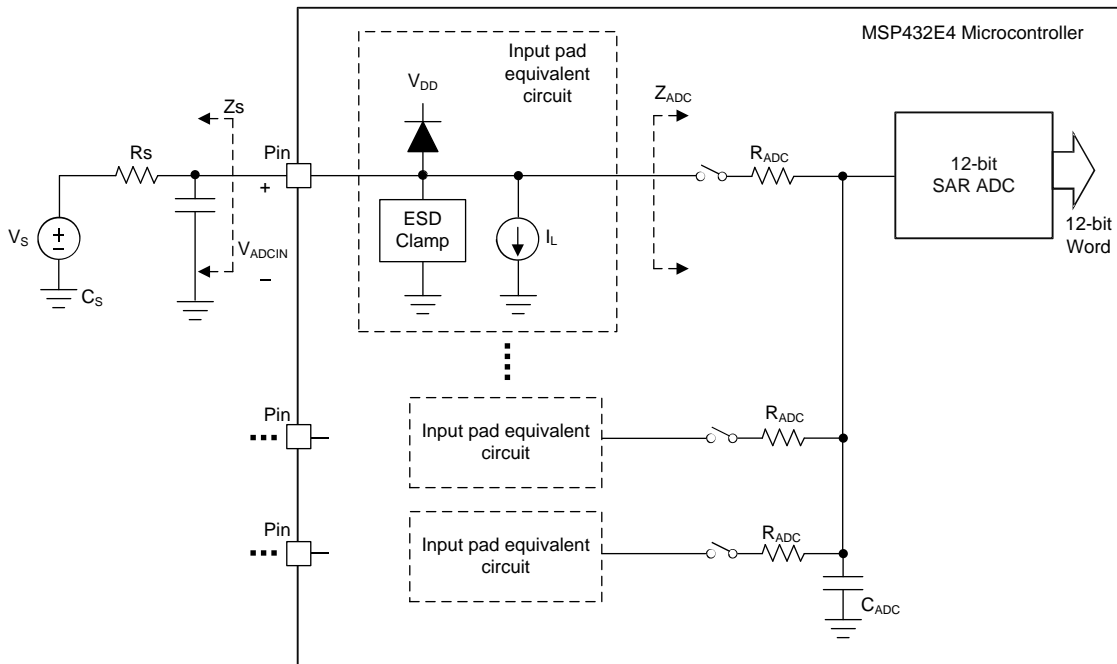

Copyright © 2017, Texas Instruments Incorporated

图 5-27. ADC Input Equivalency

5.15.12 Synchronous Serial Interface (SSI)

表 5-35. SSI Characteristics

over operating free-air temperature (unless otherwise noted) (see 图 5-28, 图 5-29, and 图 5-30)

NO.	PARAMETER		MIN	TYP	MAX	UNIT
S1	$t_{\text{CLK_PER}}$	SSIClk cycle time	As master ⁽¹⁾		16.67	ns
			As slave ⁽²⁾		100	
S2	$t_{\text{CLK_HIGH}}$	SSIClk high time	As master		8.33	ns
			As slave		50	
S3	$t_{\text{CLK_LOW}}$	SSIClk low time	As master		8.33	ns
			As slave		50	
S4	t_{CLKR}	SSIClk rise time ⁽³⁾			1.25	ns
S5	t_{CLKF}	SSIClk fall time ⁽³⁾			1.25	ns
S6	t_{TXDMOV}	Master mode: master Tx data output (to slave) valid time from edge of SSIClk			4.00	ns
S7	t_{TXDMOH}	Master mode: master Tx data output (to slave) hold time after next SSIClk	0.60			ns
S8	t_{RXDMS}	Master mode: master Rx data In (from slave) setup time	7.89			ns
S9	t_{RXDMH}	Master mode: master Rx data In (from slave) hold time	0			ns
S10	t_{TXDSOV}	Slave mode: master Tx data output (to master) valid time from edge of SSIClk			47.60 ⁽⁴⁾	ns
S11	t_{TXDSOH}	Slave mode: slave Tx data output (to master) hold time from next SSIClk	37.4 ⁽⁵⁾			ns
S13	t_{RXDSSU}	Slave mode: Rx data in (from master) setup time	0			ns
S14	t_{RXDSH}	Slave mode: Rx data in (from master) hold time	37.03 ⁽⁶⁾			ns

(1) In master mode, the system clock must be at least twice as fast as the SSIClk.

(2) In slave mode, the system clock must be at least 12 times faster than the SSIClk.

(3) The delays shown are using 12-mA drive strength.

(4) This MAX value is for the minimum slave mode t_{SYSCLK} period (8.33 ns). To find the MAX t_{TXDSOV} value for a larger t_{SYSCLK} , use the equation: $4 \times t_{\text{SYSCLK}} + 14.25$.

(5) This MIN value is for the minimum slave mode t_{SYSCLK} (8.33 ns). To find the MIN t_{TXDSOH} value for a larger t_{SYSCLK} , use the equation: $4 \times t_{\text{SYSCLK}} + 4.08$.

(6) This MIN value is for the minimum slave mode t_{SYSCLK} (8.33 ns). To find the MIN t_{TXDSH} value for a larger t_{SYSCLK} , use the equation: $4 \times t_{\text{SYSCLK}} + 3.70$.



图 5-28. SSI Timing for TI Frame Format (FRF = 01), Single Transfer Timing Measurement



图 5-29. Master Mode SSI Timing for SPI Frame Format (FRF = 00), With SPH = 1

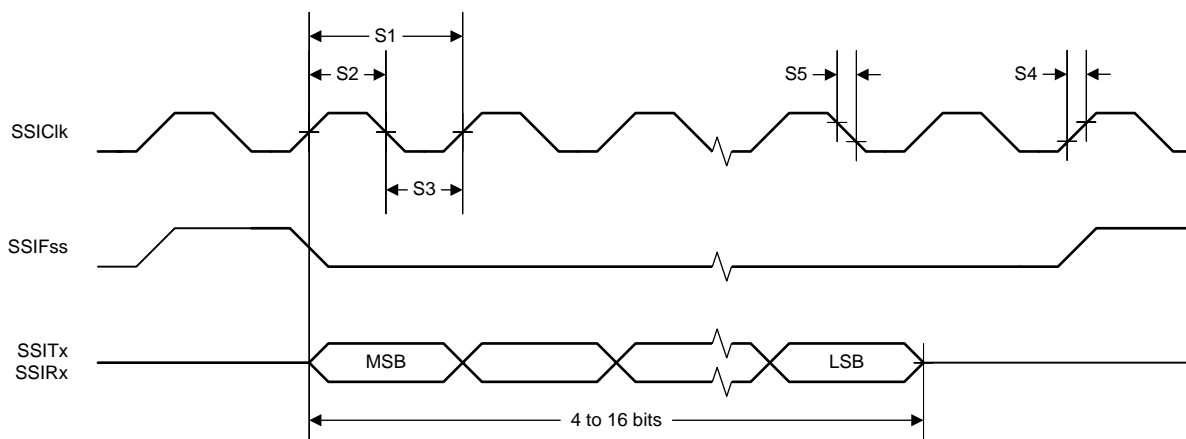

图 5-30. Slave Mode SSI Timing for SPI Frame Format (FRF = 00), With SPH = 1

表 5-36 lists the characteristics for Bi-SSI and Quad-SSI.

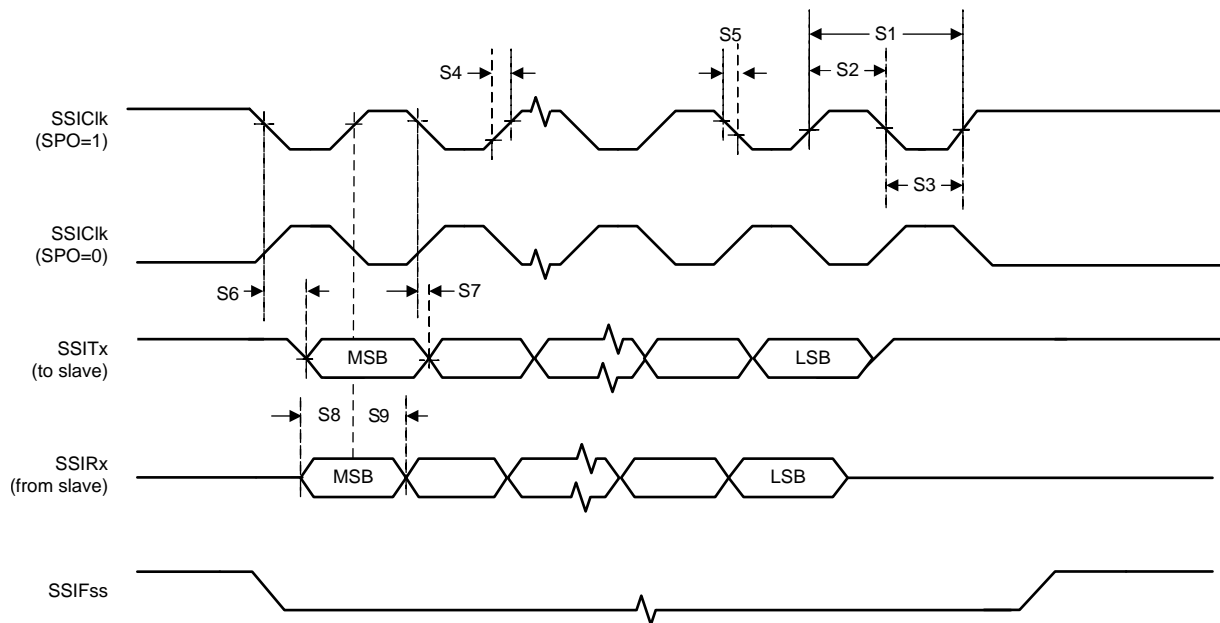
表 5-36. Bi- and Quad-SSI Characteristics⁽¹⁾

over operating free-air temperature (unless otherwise noted)

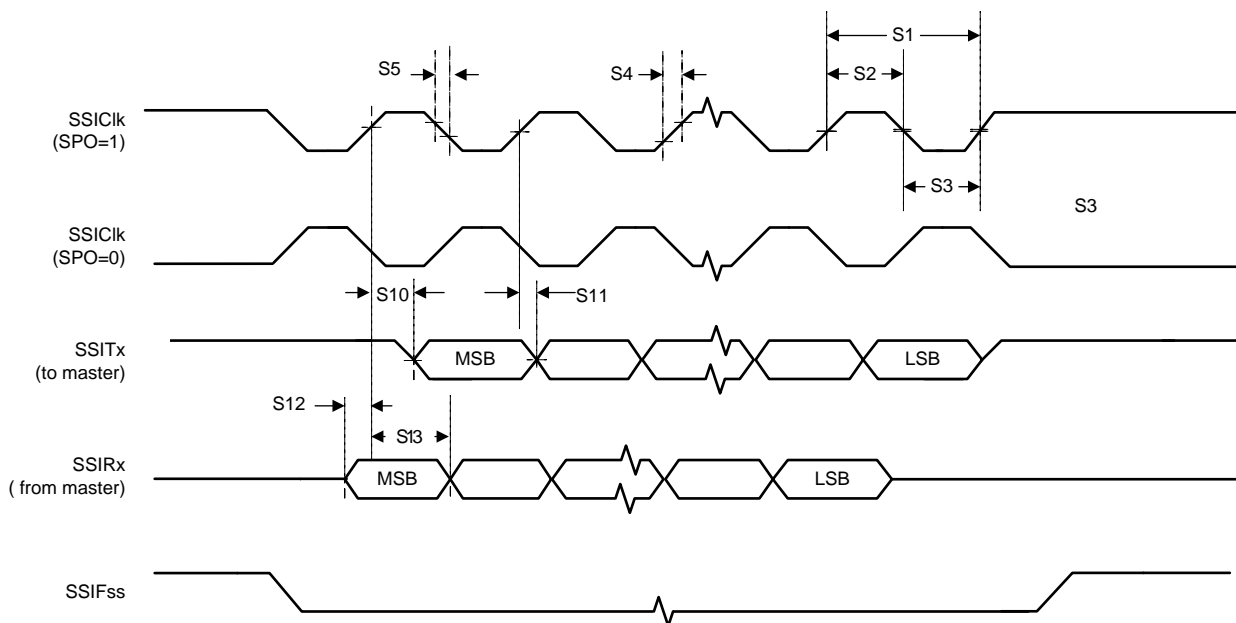
NO.	PARAMETER		MIN	TYP	MAX	UNIT
S15	t _{CLK_PER}	SSIClk cycle time, as master ⁽²⁾	16.67			ns
S16	t _{CLK_HIGH}	SSIClk high time, as master	8.33			ns
S17	t _{CLK_LOW}	SSIClk low time, as master	8.33			ns
S18	t _{CLKR}	SSIClk rise time ⁽³⁾	1.25			ns
S19	t _{CLKF}	SSIClk fall time ⁽³⁾	1.25			ns
S20	t _{TXDMOV}	Master mode: master SSInXDATn data output (to slave) valid time from edge of SSIClk			4.04	ns
S21	t _{TXDMOH}	Master mode: master SSInXDATn data output (to slave) hold time after next SSIClk	0.60			ns
S22	t _{RXDMS}	Master mode: master SSInXDATn data in (from slave) setup time	5.78			ns
S23	t _{RXDMH}	Master mode: master SSInXDATn data in (from slave) hold time	0			ns

(1) Parameters S15 to S23 correspond to parameters S1 to S9 in 图 5-28 and 图 5-29.

(2) In master mode, the system clock must be at least twice as fast as the SSIClk.

(3) The delays shown are using 12-mA drive strength.

5.15.13 Inter-Integrated Circuit (I²C) Interface

表 5-37 lists the characteristics for the I²C interface.

表 5-37. I²C Characteristics

over operating free-air temperature (unless otherwise noted) (see 图 5-31)

NO.	PARAMETER		MIN	TYP	MAX	UNIT
I1 ⁽¹⁾	t _{SCH}	Start condition hold time	36			system clock cycles
I2 ⁽¹⁾	t _{LP}	Clock low period	36			system clock cycles
I3 ⁽²⁾	t _{SRT}	I2CSCL and I2CSDA rise time (V _{IL} = 0.5 V to V _{IH} = 2.4 V)			See ⁽²⁾	ns
I4	t _{DH}	Slave		2		system clock cycles
		Master		7		
I5 ⁽³⁾	t _{SFT}	I2CSCL and I2CSDA fall time (V _{IH} = 2.4 V to V _{IL} = 0.5 V)		9	10	ns
I6 ⁽¹⁾	t _{HT}	Clock high time	24			system clock cycles
I7	t _{DS}	Data setup time	18			system clock cycles
I8 ⁽¹⁾	t _{CSR}	Start condition setup time (for repeated start condition only)	36			system clock cycles
I9 ⁽¹⁾	t _{SCS}	Stop condition setup time	24			system clock cycles
I10	t _{DV}	Slave		2		system clock cycles
		Master		(6 × (1 + TPR)) + 1		system clock cycles

- (1) Values depend on the value programmed into the TPR bit in the I²C Master Timer Period (I2CMTPR) register; a TPR programmed for the maximum I2CSCL frequency (TPR = 0x2) results in a minimum output timing listed in this table. The I²C interface is designed to scale the actual data transition time to move it to the middle of the I2CSCL low period. The actual position is affected by the value programmed into the TPR; however, the values in this table are minimum values.
- (2) Because I2CSCL and I2CSDA operate as open-drain-type signals, which the controller can only actively drive low, the time I2CSCL or I2CSDA takes to reach a high level depends on external signal capacitance and pullup resistor values.
- (3) Specified at a nominal 50-pF load



图 5-31. I²C Timing

5.15.14 Ethernet Controller

5.15.14.1 DC Characteristics

The parameters listed in 表 5-38, with the exception of R_{BIAS} , apply to transmit pins of the Ethernet PHY, which are generally the EN0TXOP and EN0TXON signals during standard operation but can also be the EN0RXIN and EN0RXIP signals if Auto-MDIX is enabled.

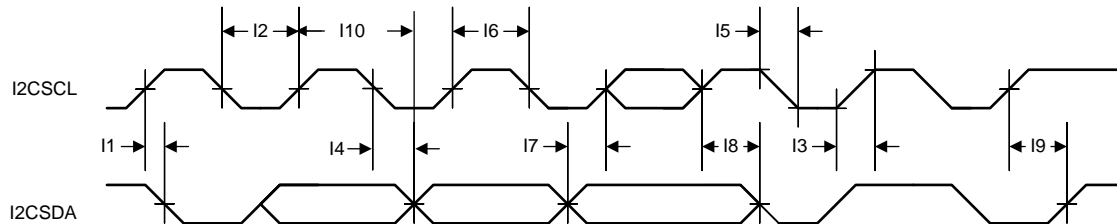
表 5-38. Ethernet PHY DC Characteristics

over operating free-air temperature (unless otherwise noted)

PARAMETER		MIN	TYP	MAX	UNIT
R_{BIAS}	Value of the pulldown resistor on the RBIAS pin	4.82	4.87	4.92	k Ω
V_{TPTD_100}	100M transmit voltage	0.95	1	1.05	V
$V_{TPTDSYM}$	100M transmit voltage symmetry	-2%		2%	
V_{OVRSH}	Output overshoot			5%	
V_{TPTD_10}	10M transmit voltage	2.2	2.5	2.8	V
V_{TH1}	10Base-T Receive threshold		200		mV

5.15.14.2 Clock Characteristics for Ethernet

表 5-39 lists the specifications of the MOSC 25-MHz crystal.

表 5-39. MOSC 25-MHz Crystal Specification⁽¹⁾

over operating free-air temperature (unless otherwise noted) (see 图 5-32)

NO.	PARAMETER	MIN	TYP	MAX	UNIT
N1	f_{MOSC25} Frequency		25		MHz
	f_{TOL} Frequency tolerance at operational temperature	0		± 50	ppm
	f_{STA} Frequency stability at 1-year aging			± 5	ppm

(1) See 表 5-12 for additional MOSC requirements.



图 5-32. MOSC Crystal Characteristics for Ethernet

表 5-40 lists the specifications of the single-ended 25-MHz oscillator.

表 5-40. MOSC Single-Ended 25-MHz Oscillator Specification ⁽¹⁾

over operating free-air temperature (unless otherwise noted) (see 图 5-33)

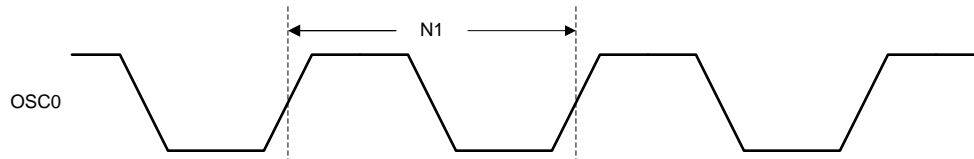
NO.	PARAMETER		MIN	TYP	MAX	UNIT
N4	f_{OSC}	Frequency		25		MHz
	f_{TOL}	Frequency tolerance at operational temperature	0		± 50	ppm
	t_{STA}	Frequency stability at 1-year aging			± 50	ppm
N5	t_{RF}	Frequency rise and fall time			1	ns
	t_J	Jitter	Cycle to cycle		50	ps
			Over 10 ms		1	ns
	DC	Duty cycle	40%		60%	

(1) See 表 5-12 for additional MOSC requirements.



图 5-33. Single-Ended MOSC Characteristics for Ethernet

5.15.14.3 AC Characteristics

表 5-41 lists the timing characteristics of the enable and reset.

表 5-41. Ethernet Controller Enable and Software Reset Timing

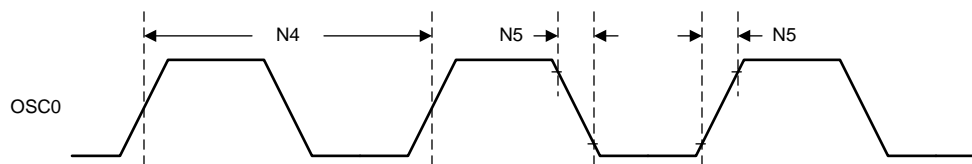
over operating free-air temperature (unless otherwise noted) (see 图 5-34)

NO.	PARAMETER	MIN	TYP	MAX	UNIT
N16	t_{EN} Time from the System Control enable of the PHY to energy on the PMD output pin ⁽¹⁾ ⁽²⁾	45			μ s
N17	t_{SWRST} Time from software reset of the PHY to energy on the PMD output pin	110			ns

- (1) The PHY is enabled through System Control by setting the P0 bit in the PCEPHY register and the R0 bit in the RCGCPHY register.
 (2) This minimum timing assumes the PHYHOLD bit in the EMACPC register is not set.



图 5-34. Reset Timing

表 5-42 lists the 100Base-TX transmit timing.

表 5-42. 100Base-TX Transmit Timing

over operating free-air temperature (unless otherwise noted) (see 图 5-35)

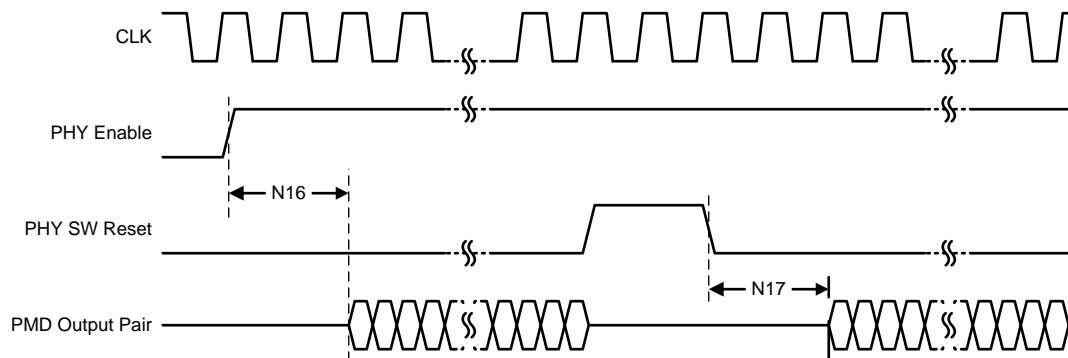
NO.	PARAMETER	MIN	TYP	MAX	UNIT
N38	t_{RF} 100-Mbps PMD output pair t_R and t_F ⁽¹⁾	3	4	5	ns
	t_{RF_MM} 100-Mbps t_R and t_F symmetry ^{(2) (3)}			500	ps
N39	t_{RF_JTTR} 100-Mbps PMD output pair transmit jitter			1.4	ns

- (1) Rise and fall times taken at 10% and 90% of the +1 or -1 amplitude.
- (2) Normal mismatch is the difference between the maximum and minimum of all rise and fall times
- (3) Choice of Ethernet transformer magnetics can affect this parameter.



图 5-35. 100 Base-TX Transmit Timing

表 5-43 lists the 10Base-T normal link pulse timing.

表 5-43. 10Base-T Normal Link Pulse Timing

over operating free-air temperature (unless otherwise noted) (see 图 5-36)

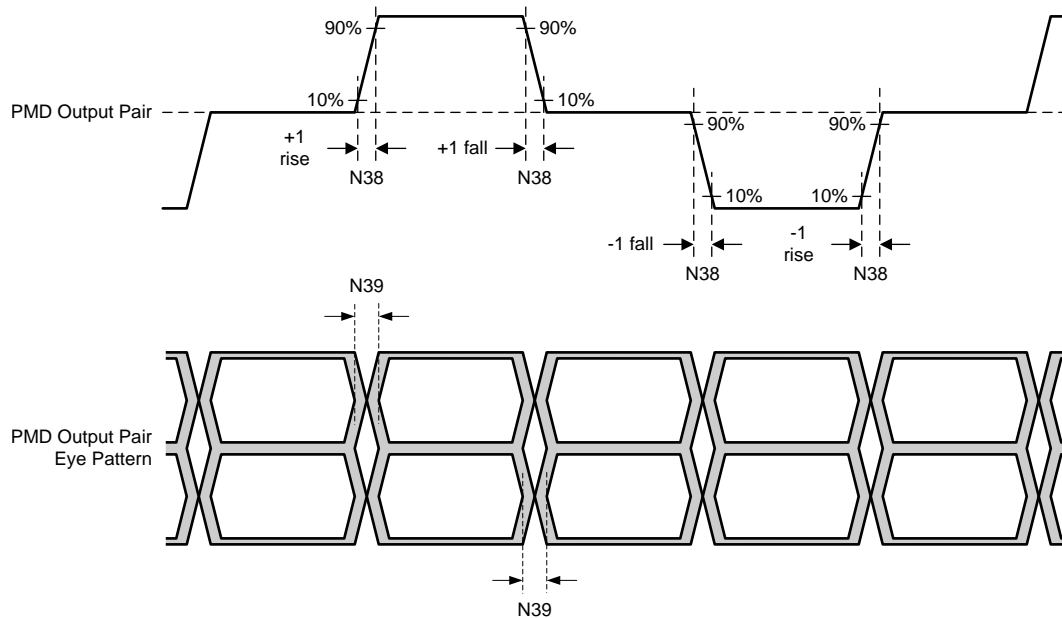
NO.	PARAMETER	MIN	TYP	MAX	UNIT
N69	t_{LP_PER} Link pulse period		76		ms
N70	t_{LP_WID} Link pulse width		100		μ s



图 5-36. 10Base-TX Normal Link Pulse Timing

表 5-44 lists the Auto-Negotiation FLP timing.

表 5-44. Auto-Negotiation Fast Link Pulse (FLP) Timing

over operating free-air temperature (unless otherwise noted) (see 图 5-37)

NO.	PARAMETER		MIN	TYP	MAX	UNIT
N72	t_{CLKP}	Clock pulse to clock pulse period		125		μ s
N73	t_{CLKDP}	Clock pulse to data pulse period		62		μ s
N74	t_{PUL}	Clock, data pulse width		110		ns
N75	t_{BRSTP}	FLP burst to flp burst period		16		ms
N76	t_{BRSTW}	Burst width		2		ms



图 5-37. Auto-Negotiation Fast Link Pulse Timing

表 5-45 lists the 100Base-TX signal detect timing.

表 5-45. 100Base-TX Signal Detect Timing

over operating free-air temperature (unless otherwise noted) (see 图 5-38)

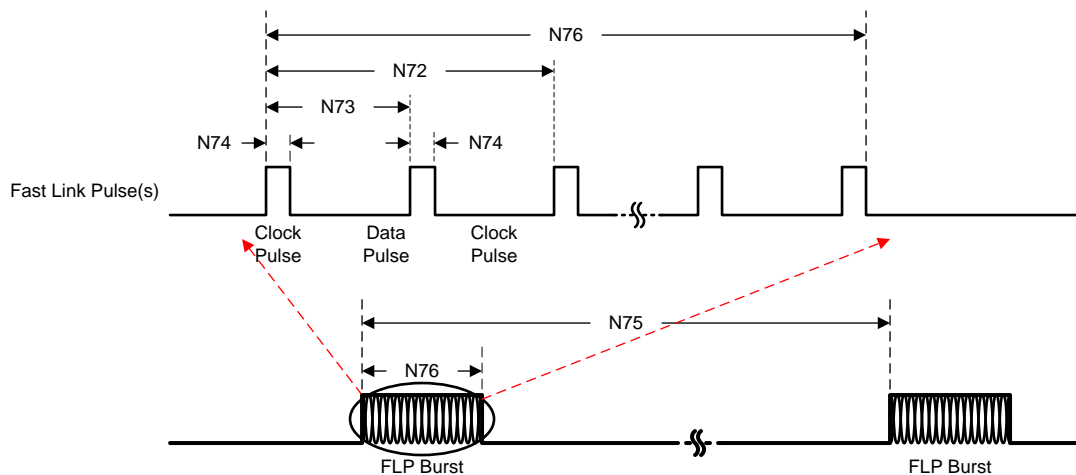
NO.	PARAMETER		MIN	TYP	MAX	UNIT
N79	t_{ON}	SD internal turnon time			100	μ s
N80	t_{OFF}	Internal turnoff time			200	μ s



图 5-38. 100Base-TX Signal Detect Timing

5.15.15 Universal Serial Bus (USB) Controller

The USB controller electrical specifications are compliant with the Universal Serial Bus Specification Rev 2.0 (full-speed and low-speed support) and the On-The-Go Supplement to the USB 2.0 Specification Rev 1.0. Some components of the USB system are integrated within the microcontroller and specific to the microcontroller design.

注

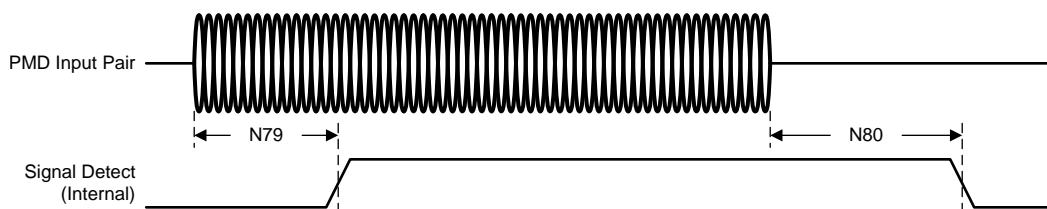
GPIO pin PB1, which can be configured as the USB0VBUS signal, is the only pin that is 5-V tolerant on the device.

表 5-46 lists the timing characteristics of the ULPI interface.

表 5-46. ULPI Interface Timing

over operating free-air temperature (unless otherwise noted) (see 图 5-39)

NO.	PARAMETER		MIN	TYP	MAX	UNIT
Timings with respect to external clock source input to USB0CLK						
U1	t_{SUC}	Setup time (control in) USB0DIR, USB0NXT	4.8			ns
U2	t_{SUD}	Setup time (data in) USB0Dn	3.5			ns
U3	t_{HTC}	Hold time (control in) USB0DIR, USB0NXT	0			ns
U4	t_{HTD}	Hold time (data in) USB0Dn	0			ns
U5	t_{ODC}	Output delay (control out) USB0STP	3.7		9.5	ns
U6	t_{ODD}	Output delay (data out) USB0Dn	3.7		9.5	ns
Timings with USB0CLK as clock output						
U1	t_{SUC}	Setup time (control in) USB0DIR, USB0NXT	6.0			ns
U2	t_{SUD}	Setup time (data in) USB0Dn	4.6			ns
U3	t_{HTC}	Hold time (control in) USB0DIR, USB0NXT	0			ns
U4	t_{HTD}	Hold time (data in) USB0Dn	0			ns
U5	t_{ODC}	Output delay (control out) USB0STP	4.0		10.6	ns
U6	t_{ODD}	Output delay (data out) USB0Dn	4.0		10.6	ns



图 5-39. ULPI Interface Timing Diagram

5.15.16 Analog Comparator

表 5-47 lists the characteristics of the comparator.

表 5-47. Analog Comparator Characteristics

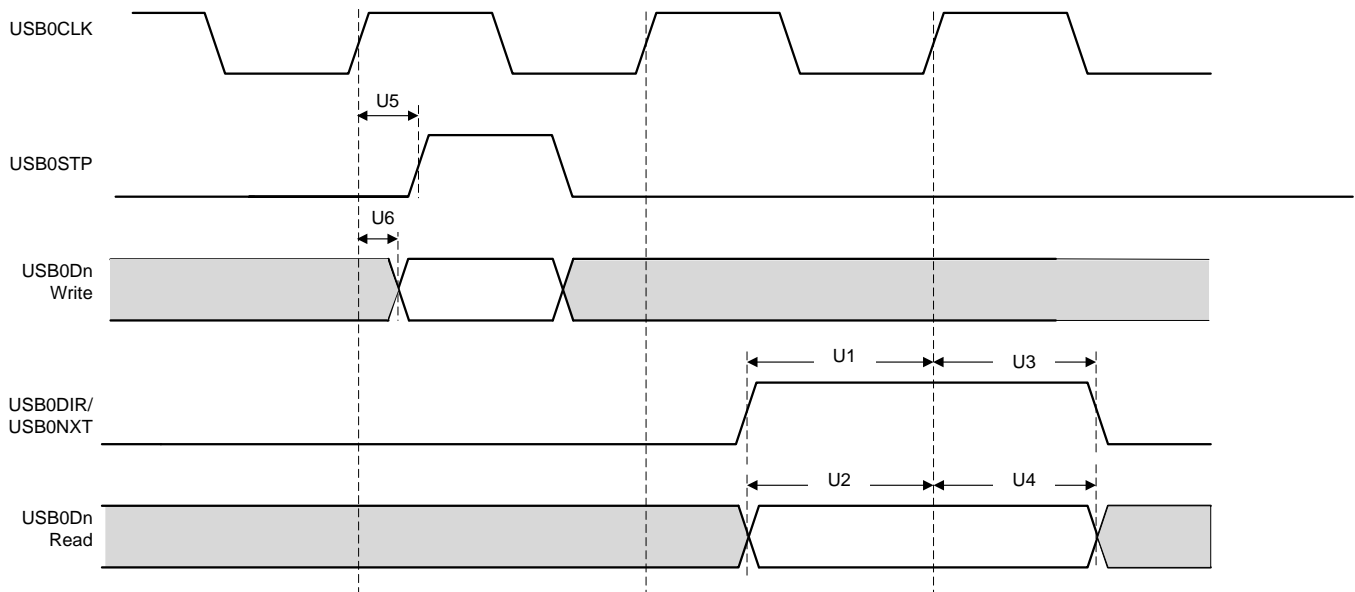
over operating free-air temperature (unless otherwise noted) ⁽¹⁾ ⁽²⁾

PARAMETER	MIN	TYP	MAX	UNIT
V_{INP} , V_{INN} ⁽³⁾ Input voltage range	GNDA		V_{DDA}	V
V_{CM} Input common-mode voltage range	GNDA		V_{DDA}	V
V_{OS} Input offset voltage		± 10	± 50 ⁽⁴⁾	mV
I_{INP} , I_{INN} Input leakage current over full voltage range			2.0	μA
C_{MRR} Common-mode rejection ratio		50		dB
t_{RT} Response time			1.0 ⁽⁵⁾	μs
t_{MC} Comparator mode change to output valid			10	μs

- (1) Best design practices suggest placing static or quiet digital I/O signals adjacent to sensitive analog inputs to reduce capacitive coupling and crosstalk.
- (2) To achieve best analog results, keep the source resistance driving the analog inputs, V_{INP} and V_{INN} , low.
- (3) The external voltage inputs to the analog comparator are designed to be highly sensitive and can be affected by external noise on the board. For this reason, V_{INP} and V_{INN} must be set to different voltage levels during idle states to ensure the analog comparator triggers are not enabled. If an internal voltage reference is used, it should be set to a mid-supply level. When operating in sleep or deep-sleep modes, disable the analog comparator module or set the external voltage inputs to different levels (greater than the input offset voltage) to achieve minimum current draw.
- (4) Measured at $V_{REF} = 100$ mV
- (5) Measured at external $V_{REF} = 100$ mV, input signal switching from 75 mV to 125 mV

表 5-48 lists the characteristics for the comparator.

表 5-48. Analog Comparator Characteristics

over operating free-air temperature (unless otherwise noted)

PARAMETER	MIN	TYP	MAX	UNIT
R_{HR} Resolution in high range		$V_{DDA} / 29.4$		V
R_{LR} Resolution in low range		$V_{DDA} / 22.12$		V
A_{HR} Absolute accuracy high range			$\pm R_{HR} / 2$	V
A_{LR} Absolute accuracy low range			$\pm R_{LR} / 2$	V

表 5-49 和 表 5-50 list the reference voltages for the comparator under different conditions.

表 5-49. Analog Comparator Voltage Reference Characteristics

$V_{DDA} = 3.3\text{ V}$, $EN = 1$, $RNG = 0$, over operating free-air temperature (unless otherwise noted)

PARAMETER	TEST CONDITIONS	MIN	TYP	MAX	UNIT
V_{IREF} Reference voltage	$VREF = 0x0$	0.731	0.786	0.841	V
	$VREF = 0x1$	0.843	0.898	0.953	
	$VREF = 0x2$	0.955	1.010	1.065	
	$VREF = 0x3$	1.067	1.122	1.178	
	$VREF = 0x4$	1.180	1.235	1.290	
	$VREF = 0x5$	1.292	1.347	1.402	
	$VREF = 0x6$	1.404	1.459	1.514	
	$VREF = 0x7$	1.516	1.571	1.627	
	$VREF = 0x8$	1.629	1.684	1.739	
	$VREF = 0x9$	1.741	1.796	1.851	
	$VREF = 0xA$	1.853	1.908	1.963	
	$VREF = 0xB$	1.965	2.020	2.076	
	$VREF = 0xC$	2.078	2.133	2.188	
	$VREF = 0xD$	2.190	2.245	2.300	
	$VREF = 0xE$	2.302	2.357	2.412	
	$VREF = 0xF$	2.414	2.469	2.525	

表 5-50. Analog Comparator Voltage Reference Characteristics

$V_{DDA} = 3.3\text{ V}$, $EN = 1$, $RNG = 1$, over operating free-air temperature (unless otherwise noted)

PARAMETER	TEST CONDITIONS	MIN	TYP	MAX	UNIT
V_{IREF} Reference voltage	$VREF = 0x0$	0.000	0.000	0.074	V
	$VREF = 0x1$	0.076	0.149	0.223	
	$VREF = 0x2$	0.225	0.298	0.372	
	$VREF = 0x3$	0.374	0.448	0.521	
	$VREF = 0x4$	0.523	0.597	0.670	
	$VREF = 0x5$	0.672	0.746	0.820	
	$VREF = 0x6$	0.822	0.895	0.969	
	$VREF = 0x7$	0.971	1.044	1.118	
	$VREF = 0x8$	1.120	1.193	1.267	
	$VREF = 0x9$	1.269	1.343	1.416	
	$VREF = 0xA$	1.418	1.492	1.565	
	$VREF = 0xB$	1.567	1.641	1.715	
	$VREF = 0xC$	1.717	1.790	1.864	
	$VREF = 0xD$	1.866	1.939	2.013	
	$VREF = 0xE$	2.015	2.089	2.162	
	$VREF = 0xF$	2.164	2.238	2.311	

5.15.17 Pulse-Width Modulator (PWM)

表 5-51 lists the PWM timing characteristics.

表 5-51. PWM Timing Characteristics

over operating free-air temperature (unless otherwise noted)

PARAMETER		MIN	TYP	MAX	UNIT
t_{FLTW}	Minimum fault pulse width	2			PWM clock periods
t_{FLTMAX}	MnFAULTn assertion to PWM inactive ⁽¹⁾			24 + (1 PWM clock)	ns
t_{FLTMIN}	MnFAULTn deassertion to PWM active ⁽²⁾	5			ns

(1) This parameter value can vary depending on the PWM clock frequency which is controlled by the System Clock and a programmable divider field in the PWMCC register.

(2) The latch and minimum fault period functions that can be enabled in the PWMnCTL register can change the timing of this parameter.

5.15.18 Emulation and Debug

表 5-52 lists the JTAG characteristics.

表 5-52. JTAG Characteristics

over operating free-air temperature (unless otherwise noted) (see 图 5-40 and 图 5-41)

NO.	PARAMETER		MIN	TYP	MAX	UNIT
J1	f_{TCK}	TCK operational clock frequency	0		10	MHz
J2	t_{TCK}	TCK operational clock period	100			ns
J3	t_{TCK_LOW}	TCK clock low time		$t_{TCK} / 2$		ns
J4	t_{TCK_HIGH}	TCK clock high time		$t_{TCK} / 2$		ns
J5	t_{TCK_R}	TCK rise time	0		10	ns
J6	t_{TCK_F}	TCK fall time	0		10	ns
J7	t_{TMS_SU}	TMS setup time to TCK rise	8			ns
J8	t_{TMS_HLD}	TMS hold time from TCK rise	4			ns
J9	t_{TDI_SU}	TDI setup time to TCK rise	18			ns
J10	t_{TDI_HLD}	TDI hold time from TCK rise	4			ns
J11	t_{TDO_ZDV}	TCK fall to data valid from Hi-Z	2-mA drive	13	35	ns
			4-mA drive	9	26	
			8-mA drive	8	26	
			8-mA drive with slew rate control	10	29	
			10-mA drive	11	13	
J12	t_{TDO_DV}	TCK fall to data valid from data valid	2-mA drive	14	20	ns
			4-mA drive	10	26	
			8-mA drive	8	21	
			8-mA drive with slew rate control	10	26	
			10-mA drive	12	14	
J13	t_{TDO_DVZ}	TCK fall to Hi-Z from data valid	2-mA drive	7	16	ns
			4-mA drive	7	16	
			8-mA drive	7	16	
			8-mA drive with slew rate control	8	19	
			10-mA drive	20	22	
			12-mA drive	20	25	



图 5-40. JTAG Test Clock Input Timing



图 5-41. JTAG Test Access Port (TAP) Timing

6 Detailed Description

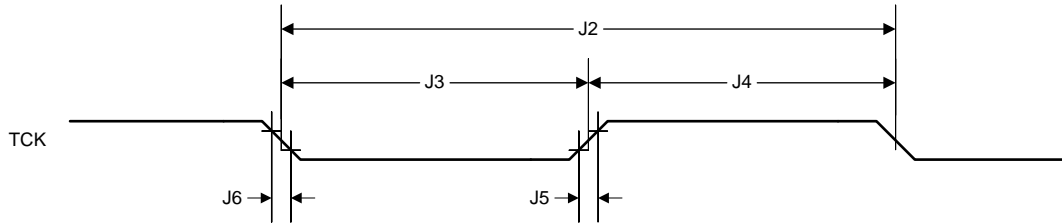
6.1 Overview

The SimpleLink MSP432E401Y Arm Cortex-M4 microcontroller (MCU) provides top performance and advanced integration. The MSP432E4 product family is positioned for cost-effective applications requiring significant control processing and connectivity capabilities such as the following:

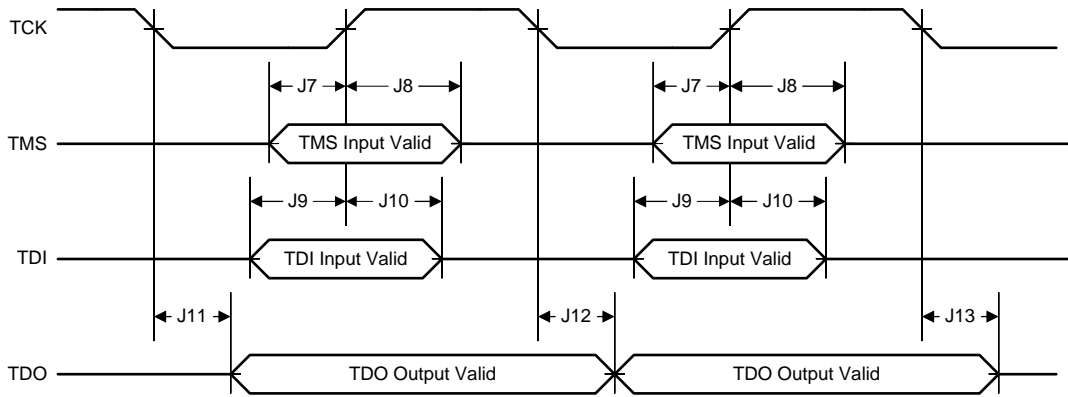
- Industrial communication equipment
- Network appliances, gateways, and adapters
- Residential and commercial site monitoring and control
- Remote connectivity and monitoring
- Security and access systems
- HMI control panels
- Factory automation control
- Test and measurement equipment
- Fire and security systems
- Motion control and power inversion
- Medical instrumentation
- Gaming equipment
- Electronic point-of-sale (POS) displays
- Smart energy and smart grid solutions
- Intelligent lighting control
- Vehicle tracking

The MSP432E401Y MCU integrates a large variety of rich communication features to enable a new class of highly connected designs that can support critical, real-time control with a balance between performance and power. The MCU features integrated communication peripherals and other high-performance analog and digital functions to offer a strong foundation for many different target uses, from human-machine interface to networked system management controllers.

In addition, the MSP432E401Y MCU offers the advantages of widely available development tools from Arm, System-on-Chip (SoC) infrastructure, and a large user community. Additionally, this MCU uses the Thumb-compatible Thumb-2 instruction set from Arm to reduce memory requirements and, thereby, cost. Finally, when using the SimpleLink SDK, the MSP432E401Y MCU is code-compatible with all members of the SimpleLink series, providing flexibility to fit precise needs.

TI offers a complete solution to get to market quickly, with evaluation and development boards; white papers and application notes; an easy-to-use peripheral driver library; and a strong support, sales, and distributor network.

6.2 Functional Block Diagram

图 6-1 shows the features on the MSP432E401Y MCU. Two on-chip buses connect the core to the peripherals. The Advanced Peripheral Bus (APB) bus is the legacy bus. The Advanced High-Performance Bus (AHB) bus provides better back-to-back access performance than the APB bus.

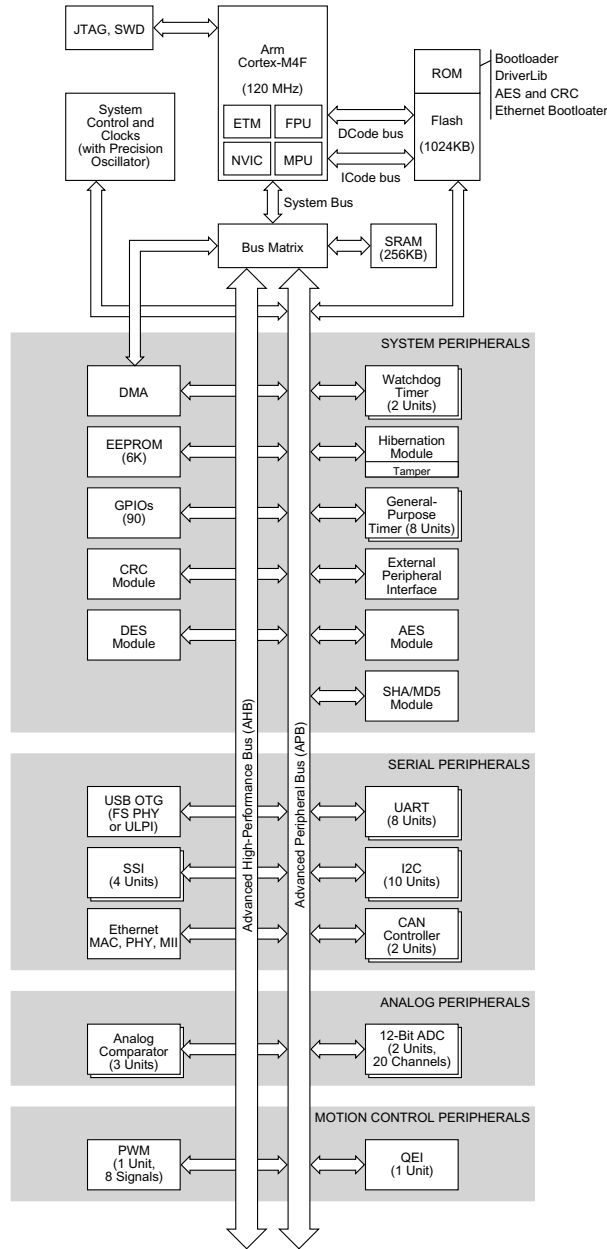

Copyright © 2017, Texas Instruments Incorporated

图 6-1. MSP432E401Y High-Level Block Diagram

6.3 Arm Cortex-M4F Processor Core

All members of the MSP432E4 family are designed around an Arm Cortex-M processor core. The Arm Cortex-M processor provides the core for a high-performance low-cost platform that meets the needs of minimal memory implementation, reduced pin count, and low power consumption, while delivering outstanding computational performance and exceptional system response to interrupts.

6.3.1 Processor Core

Features of the processor core include:

- 32-bit Arm Cortex-M4F architecture optimized for small-footprint embedded applications
- 120-MHz operation; 150 DMIPS performance
- Outstanding processing performance combined with fast interrupt handling
- Thumb-2 mixed 16- and 32-bit instruction set delivers the high performance expected of a 32-bit Arm core in a compact memory size usually associated with 8- and 16-bit devices, typically in the range of a few kilobytes of memory for MCU-class applications.
 - Single-cycle multiply instruction and hardware divide
 - Atomic bit manipulation (bit-banding), delivering maximum memory use and streamlined peripheral control
 - Unaligned data access, enabling data to be efficiently packed into memory
- IEEE 754-compliant single-precision floating-point unit (FPU)
- 16-bit SIMD vector processing unit
- Fast code execution permits slower processor clock or increases sleep mode time
- Harvard architecture characterized by separate buses for instruction and data
- Efficient processor core, system, and memories
- Hardware division and fast digital-signal-processing orientated multiply accumulate
- Saturating arithmetic for signal processing
- Deterministic high-performance interrupt handling for time-critical applications
- Memory protection unit (MPU) to provide a privileged mode for protected operating system functionality
- Enhanced system debug with extensive breakpoint and trace capabilities
- Serial Wire Debug and Serial Wire Trace reduce the number of pins required for debugging and tracing
- Migration from the Arm7[®] processor family for better performance and power efficiency
- Optimized for single-cycle flash memory use up to specific frequencies; see the *Internal Memory* chapter of the [MSP432E4 SimpleLink™ Microcontrollers Technical Reference Manual](#) for more information.
- Ultra-low-power consumption with integrated sleep modes

6.3.2 System Timer (SysTick)

SysTick provides a simple, 24-bit, clear-on-write, decrementing, wrap-on-zero counter with a flexible control mechanism. The counter can be used in several different ways, for example:

- An RTOS tick timer that fires at a programmable rate (for example, 100 Hz) and invokes a SysTick routine
- A high-speed alarm timer using the system clock
- A variable rate alarm or signal timer—the duration is range-dependent on the reference clock used and the dynamic range of the counter
- A simple counter used to measure time to completion and time used
- An internal clock-source control based on missing or meeting durations

6.3.3 Nested Vectored Interrupt Controller (NVIC)

The NVIC and Cortex-M4F core prioritize and handle all exceptions in handler mode. The processor state is automatically stored to the stack on an exception and automatically restored from the stack at the end of the interrupt service routine (ISR). The interrupt vector is fetched in parallel to the state saving, enabling efficient interrupt entry. The processor supports tail-chaining, meaning that back-to-back interrupts can be performed without the overhead of state saving and restoration. Software can set 8 priority levels on 7 exceptions (system handlers) and 109 interrupts.

- Deterministic, fast interrupt processing: always 12 cycles, or just 6 cycles with tail-chaining (these values reflect no FPU stacking)
- External nonmaskable interrupt signal (NMI) available for immediate execution of NMI handler for safety critical applications
- Dynamically reprioritizable interrupts
- Exceptional interrupt handling through hardware implementation of required register manipulations

表 6-1 lists the interrupts.

表 6-1. Interrupts

VECTOR NUMBER	INTERRUPT NUMBER (BIT IN INTERRUPT REGISTERS)	VECTOR ADDRESS OR OFFSET	DESCRIPTION
0 to 15	–	0x0000.0000 to 0x0000.003C	Processor exceptions
16	0	0x0000.0040	GPIO Port A
17	1	0x0000.0044	GPIO Port B
18	2	0x0000.0048	GPIO Port C
19	3	0x0000.004C	GPIO Port D
20	4	0x0000.0050	GPIO Port E
21	5	0x0000.0054	UART0
22	6	0x0000.0058	UART1
23	7	0x0000.005C	SSI0
24	8	0x0000.0060	I2C0
25	9	0x0000.0064	PWM fault
26	10	0x0000.0068	PWM generator 0
27	11	0x0000.006C	PWM generator 1
28	12	0x0000.0070	PWM generator 2
29	13	0x0000.0074	QE10
30	14	0x0000.0078	ADC0 sequence 0
31	15	0x0000.007C	ADC0 sequence 1
32	16	0x0000.0080	ADC0 sequence 2
33	17	0x0000.0084	ADC0 sequence 3
34	18	0x0000.0088	Watchdog timers 0 and 1
35	19	0x0000.008C	16-/32-Bit Timer 0A
36	20	0x0000.0090	16-/32-Bit Timer 0B
37	21	0x0000.0094	16-/32-Bit Timer 1A
38	22	0x0000.0098	16-/32-Bit Timer 1B
39	23	0x0000.009C	16-/32-Bit Timer 2A
40	24	0x0000.00A0	16-/32-Bit Timer 2B
41	25	0x0000.00A4	Analog comparator 0
42	26	0x0000.00A8	Analog comparator 1
43	27	0x0000.00AC	Analog comparator 2
44	28	0x0000.00B0	System control

表 6-1. Interrupts (continued)

VECTOR NUMBER	INTERRUPT NUMBER (BIT IN INTERRUPT REGISTERS)	VECTOR ADDRESS OR OFFSET	DESCRIPTION
45	29	0x0000.00B4	Flash memory control
46	30	0x0000.00B8	GPIO port F
47	31	0x0000.00BC	GPIO port G
48	32	0x0000.00C0	GPIO port H
49	33	0x0000.00C4	UART2
50	34	0x0000.00C8	SSI1
51	35	0x0000.00CC	16-/32-Bit Timer 3A
52	36	0x0000.00D0	16-/32-Bit Timer 3B
53	37	0x0000.00D4	I2C1
54	38	0x0000.00D8	CAN0
55	39	0x0000.00DC	CAN1
56	40	0x0000.00E0	Ethernet MAC
57	41	0x0000.00E4	HIB
58	42	0x0000.00E8	USB MAC
59	43	0x0000.00EC	PWM generator 3
60	44	0x0000.00F0	μDMA 0 Software
61	45	0x0000.00F4	μDMA 0 Error
62	46	0x0000.00F8	ADC1 sequence 0
63	47	0x0000.00FC	ADC1 sequence 1
64	48	0x0000.0100	ADC1 sequence 2
65	49	0x0000.0104	ADC1 sequence 3
66	50	0x0000.0108	EPI0
67	51	0x0000.010C	GPIO port J
68	52	0x0000.0110	GPIO port K
69	53	0x0000.0114	GPIO port L
70	54	0x0000.0118	SSI2
71	55	0x0000.011C	SSI3
72	56	0x0000.0120	UART3
73	57	0x0000.0124	UART4
74	58	0x0000.0128	UART5
75	59	0x0000.012C	UART6
76	60	0x0000.0130	UART7
77	61	0x0000.0134	I2C2
78	62	0x0000.0138	I2C3
79	63	0x0000.013C	Timer 4A
80	64	0x0000.0140	Timer 4B
81	65	0x0000.0144	Timer 5A
82	66	0x0000.0148	Timer 5B
83	67	0x0000.014C	Floating-Point Exception (imprecise)
84	68	–	Reserved
85	69	–	Reserved
86	70	0x0000.0158	I2C4
87	71	0x0000.015C	I2C5
88	72	0x0000.0160	GPIO port M
89	73	0x0000.0164	GPIO port N
90	74	–	Reserved

表 6-1. Interrupts (continued)

VECTOR NUMBER	INTERRUPT NUMBER (BIT IN INTERRUPT REGISTERS)	VECTOR ADDRESS OR OFFSET	DESCRIPTION
91	75	0x0000.016C	Tamper
92	76	0x0000.017	GPIO port P (Summary or P0)
93	77	0x0000.0174	GPIO port P1
94	78	0x0000.0178	GPIO port P2
95	79	0x0000.017C	GPIO port P3
96	80	0x0000.0180	GPIO port P4
97	81	0x0000.0184	GPIO port P5
98	82	0x0000.0188	GPIO port P6
99	83	0x0000.018C	GPIO port P7
100	84	0x0000.0190	GPIO port Q (summary or Q0)
101	85	0x0000.0194	GPIO port Q1
102	86	0x0000.0198	GPIO port Q2
103	87	0x0000.019C	GPIO port Q3
104	88	0x0000.01A0	GPIO port Q4
105	89	0x0000.01A4	GPIO port Q5
106	90	0x0000.01A8	GPIO port Q6
107	91	0x0000.01AC	GPIO port Q7
108	92	–	Reserved
109	93	–	Reserved
110	94	0x0000.01B8	SHA/MD5
111	95	0x0000.01BC	AES
112	96	0x0000.01C0	DES
113	97	–	Reserved
114	98	0x0000.01C8	16-/32-Bit Timer 6A
115	99	0x0000.01CC	16-/32-Bit Timer 6B
116	100	0x0000.01D0	16-/32-Bit Timer 7A
117	101	0x0000.01D4	16-/32-Bit Timer 7B
118	102	0x0000.01D8	I2C6
119	103	0x0000.01DC	I2C7
120	104	–	Reserved
121	105	–	Reserved
122	106	–	Reserved
123	107	–	Reserved
124	108	–	Reserved
125	109	0x0000.01F4	I2C8
126	110	0x0000.01F8	I2C9
127	111	–	Reserved

6.3.4 System Control Block (SCB)

The SCB provides system implementation information and system control, including configuration, control, and reporting of system exceptions.

6.3.5 Memory Protection Unit (MPU)

The MPU supports the standard Arm7 Protected Memory System Architecture (PMSA) model. The MPU provides full support for protection regions, overlapping protection regions, access permissions, and exporting memory attributes to the system.

6.3.6 Floating-Point Unit (FPU)

The FPU fully supports single-precision add, subtract, multiply, divide, multiply-and-accumulate, and square root operations. It also provides conversions between fixed-point and floating-point data formats, and floating-point constant instructions.

- 32-bit instructions for single-precision (C float) data-processing operations
- Combined multiply and accumulate instructions for increased precision (fused MAC)
- Hardware support for conversion, addition, subtraction, multiplication with optional accumulate, division, and square-root
- Hardware support for denormals and all IEEE rounding modes
- 32 dedicated 32-bit single-precision registers, also addressable as 16 double-word registers
- Decoupled 3-stage pipeline

6.4 On-Chip Memory

The following on-chip memories are supported:

- 256KB of single-cycle SRAM
- 1024KB of flash memory
- 6KB of EEPROM
- Internal ROM loaded with SimpleLink SDK software:
 - Peripheral driver library
 - Bootloader

6.4.1 SRAM

The MSP432E401Y MCU provides 256KB of single-cycle on-chip SRAM. The internal SRAM of the device is at offset 0x2000.0000 of the device memory map.

The SRAM is implemented using four 32-bit-wide interleaving SRAM banks (separate SRAM arrays), which allow for increased speed between memory accesses. The SRAM memory provides nearly 2 GBps of memory bandwidth at a 120-MHz clock frequency.

Because read-modify-write (RMW) operations are time consuming, Arm has introduced bit-banding technology in the Cortex-M4F processor. With a bit-band-enabled processor, certain regions in the memory map (SRAM and peripheral space) can use address aliases to access individual bits in an atomic operation.

Data can be transferred to and from SRAM by the following masters:

- μ DMA
- USB
- Ethernet controller

6.4.2 Flash Memory

The MSP432E401Y MCU provides 1024KB of on-chip flash memory. The flash memory is configured as four banks of 16K \times 128 bits (4 \times 256KB total) that are 2-way interleaved. Memory blocks can be marked as read only or execute only, providing different levels of code protection. Read-only blocks cannot be erased or programmed, protecting the contents of those blocks from being modified. Execute-only blocks cannot be erased or programmed, and can only be read by the controller instruction fetch mechanism, protecting the contents of those blocks from being read by either the controller or a debugger.

Two sets of instruction prefetch buffers provide enhanced performance and power savings. Each prefetch buffer is 2 \times 256 bits and can be combined as a 4 \times 256-bit prefetch buffer.

The flash can also be accessed by the μ DMA in run mode.

6.4.3 ROM

The ROM is preprogrammed with the following software and programs:

- Peripheral driver library
- Bootloader

The SimpleLink MSP432E4 SDK driver library is a royalty-free software library for controlling on-chip peripherals with a bootloader capability. The library performs both peripheral initialization and control functions, with a choice of polled or interrupt-driven peripheral support. In addition, the library is designed to take full advantage of the stellar interrupt performance of the Arm Cortex-M4F core. No special pragmas or custom assembly code prologue or epilogue functions are required. For applications that require in-field programmability, the royalty-free bootloader can act as an application loader and support in-field firmware updates.

6.4.4 EEPROM

The EEPROM includes the following features:

- 6KB of memory accessible as 1536 32-bit words
- 96 blocks of 16 words (64 bytes) each
- Built-in wear leveling
- Access protection per block
- Lock protection option for the whole peripheral as well as per block using 32-bit to 96-bit unlock codes (application selectable)
- Interrupt support for write completion to avoid polling
- Endurance of 500k writes (when writing at fixed offset in every alternate page in circular fashion) to 15M operations (when cycling through two pages) per each 2-page block.

6.4.5 Memory Map

The device supports a 4GB address space that is divided into eight 512MB zones (see [图 6-2](#)).



图 6-2. Device Memory Zones

6.5 Peripherals

6.5.1 External Peripheral Interface (EPI)

The EPI provides access to external devices using a parallel path. Unlike communications peripherals such as SSI, UART, and I²C, the EPI acts as a bus to external peripherals and memory.

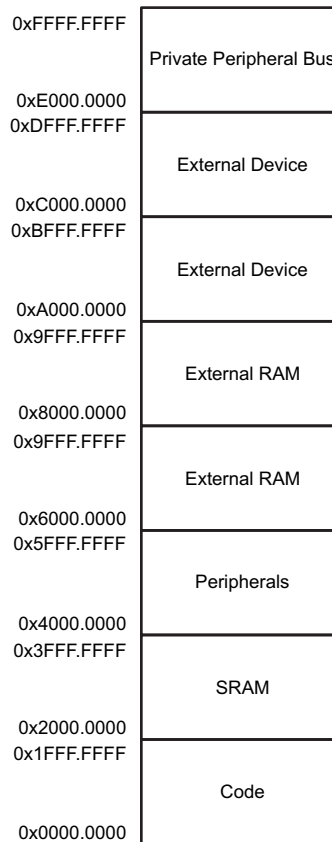
The EPI has the following features:

- 8-, 16-, or 32-bit dedicated parallel bus for external peripherals and memory
- Memory interface supports contiguous memory access independent of data bus width, thus enabling code execution directly from SDRAM, SRAM, and flash memory
- Blocking and nonblocking reads
- Separates processor from timing details through use of an internal write FIFO
- Efficient transfers using μ DMA
 - Separate channels for read and write
 - Read channel request asserted by programmable levels on the internal Nonblocking Read FIFO (NBRFIFO)
 - Write channel request asserted by empty on the internal Write FIFO (WFIFO)

The EPI supports three primary functional modes: SDRAM mode, traditional host-bus mode, and general-purpose mode. The EPI module also provides custom GPIOs; however, unlike regular GPIOs, the EPI module uses a FIFO in the same way as a communication mechanism and is speed-controlled using clocking.

- SDRAM mode
 - Supports $\times 16$ (single data rate) SDRAM at up to 60 MHz
 - Supports low-cost SDRAMs up to 64MB (512 Mb)
 - Includes automatic refresh and access to all banks and rows
 - Includes a sleep (standby) mode to keep contents active with minimal power draw
 - Multiplexed address and data interface for reduced pin count
- Host-bus mode
 - Traditional $\times 8$ and $\times 16$ MCU bus interface capabilities
 - Similar device compatibility options as PIC, ATmega, 8051, and others
 - Access to SRAM, NOR flash memory, and other devices, with up to 1MB of addressing in nonmultiplexed mode and 256MB in multiplexed mode (512MB in host bus 16 mode with no byte selects)
 - Support for up to 512Mb PSRAM in quad chip select mode, with dedicated configuration register read and write enable
 - Support of both muxed and demuxed address and data
 - Access to a range of devices supporting the nonaddress FIFO $\times 8$ and $\times 16$ interface variant, with support for external FIFO (XFIFO) EMPTY and FULL signals
 - Speed controlled, with read and write data wait-state counters
 - Support for read or write burst mode to Host Bus
 - Multiple chip-select modes including single, dual, and quad chip selects, with and without ALE
 - External iRDY signal provided for stall capability of reads and writes
 - Manual chip-enable (or use extra address pins)
- General-purpose mode
 - Wide parallel interfaces for fast communications with CPLDs and FPGAs
 - Data widths up to 32 bits
 - Data rates up to 150 MB/second
 - Optional "address" sizes from 4 bits to 20 bits
 - Optional clock output, read and write strobes, framing (with counter-based size), and clock-enable input
- General parallel GPIO
 - 1 to 32 bits, FIFO with speed control
 - Useful for custom peripherals or for digital data acquisition and actuator controls

6.5.2 Cyclical Redundancy Check (CRC)

The CRC computation module is for uses such as message transfer and safety system checks. This module can be used with the AES and DES modules. The CRC has the following features:

- Support four major CRC forms:
 - CRC16-CCITT as used by CCITT/ITU X.25
 - CRC16-IBM as used by USB and ANSI
 - CRC32-IEEE as used by IEEE 802.3 and MPEG-2
 - CRC32C as used by G.Hn
- Allows word and byte feed
- Supports automatic initialization and manual initialization
- Supports MSb and LSb
- Supports CCITT post-processing
- Can be fed by μ DMA, flash memory, and code

6.5.3 Advanced Encryption Standard (AES) Accelerator

The AES accelerator module provides hardware-accelerated data encryption and decryption operations based on a binary key. The AES module is a symmetric cipher module that supports a 128-, 192-, or 256-bit key in hardware for both encryption and decryption.

The AES has following features:

- Support for basic AES encryption and decryption operations:
 - Galois/counter mode (GCM) with basic GHASH operation
 - Counter mode with CBC-MAC (CCM)
 - XTS mode
- Availability of the following feedback operating modes:
 - Electronic code book mode (ECB)
 - Cipher block chaining mode (CBC)
 - Counter mode (CTR)
 - Cipher feedback mode (CFB), 128-bit
 - F8 mode
- Key sizes 128-, 192-, and 256-bits
- Support for CBC_MAC and Fedora 9 (F9) authentication modes
- Basic GHASH operation (when selecting no encryption)
- Key scheduling in hardware
- Support for μ DMA transfers
- Fully synchronous design

6.5.4 Data Encryption Standard (DES) Accelerator

The DES module provides hardware accelerated data encryption and decryption functions. The module runs either the single DES or the triple DES (3DES) algorithm and supports electronic codebook (ECB), cipher block chaining (CBC), and cipher feedback (CFB) modes of operation.

The DES accelerator includes the following main features:

- DES/3DES encryption and decryption algorithm compliant with the [FIPS 180-3 standard](#)
- Feedback modes: ECB, CBC, CFB
- Host interrupt or μ DMA driven modes of operation. μ DMA support for data and context in and result out
- Fully synchronous design
- Internal wide-bus interface

6.5.5 Secure Hash Algorithm/Message Digest Algorithm (SHA/MD5) Accelerator

The SHA/MD5 module provides hardware-accelerated hash functions and can run:

- MD5 message digest algorithm developed by Ron Rivest in 1991
- SHA-1 algorithm compliant with the [FIPS 180-3 standard](#)
- SHA-2 (SHA-224 and SHA-256) algorithm compliant with the [FIPS 180-3 standard](#)
- Hash message authentication code (HMAC) operation

The algorithms produce a condensed representation of a message or a data file, which can then be used to verify the message integrity.

The SHA/MD5 accelerator module includes the following main features:

- Hashing of 0 to $(2^{33} - 2)$ bytes of data [of which $(2^{32} - 1)$ bytes are in one pass] using the MD5, SHA-1, SHA-224, or SHA-256 hash algorithm (byte granularity only, no support for bit granularity)
- Automatic HMAC key preprocessing for HMAC keys up to 64 bytes

- Host-assisted HMAC key preprocessing for HMAC keys larger than 64 bytes
- HMAC from precomputes (inner and outer digest) for improved performance on small blocks
- Supports μ DMA operation for data and context in and result out transfers
- Supports interrupt to read the digest (signature)

6.5.6 Serial Communications Peripherals

Both asynchronous and synchronous serial communications are supported with:

- 10/100 Ethernet MAC with advanced IEEE 1588 PTP hardware; integrated PHY provided
- Two CAN 2.0 A and B controllers
- USB 2.0 controller OTG, host, or device with optional high speed using external PHY through ULPI interface
- Eight UARTs with IrDA, 9-bit, and ISO 7816 support
- Ten I2C modules with four transmission speeds including high-speed mode
- Four Quad Synchronous Serial Interface (QSSI) modules with bi- and quad-SSI support

The following sections provide more detail on each of these communications functions.

6.5.6.1 Ethernet MAC and PHY

The Ethernet controller consists of a fully integrated media access controller (MAC) and network physical (PHY) interface with the following features:

- Conforms to the IEEE 802.3 specification
 - 10BASE-T and 100BASE-TX IEEE-802.3 compliant
 - Supports 10- and 100-Mbps data transmission rates
 - Supports full-duplex and half-duplex (CSMA/CD) operation
 - Supports flow control and back pressure
 - Full-featured and enhanced auto-negotiation
 - Supports IEEE 802.1Q VLAN tag detection
- Conforms to IEEE 1588-2002 timestamp PTP protocol and the IEEE 1588-2008 advanced timestamp specification
 - Transmit and receive frame timestamping
 - Precision time protocol
 - Flexible pulse per second output
 - Supports coarse and fine correction methods
- Multiple addressing modes
 - Four MAC address filters
 - Programmable 64-bit hash filter for multicast address filtering
 - Promiscuous mode support
- Processor offloading
 - Programmable insertion (TX) or deletion (RX) of preamble and start-of-frame data
 - Programmable generation (TX) or deletion (RX) of CRC and pad data
 - IP header and hardware checksum checking (IPv4, IPv6, TCP, UDP, ICMP)
- Highly configurable
 - LED activity selection
 - Supports network statistics with RMON and MIB counters
 - Supports magic packet and wake-up frames

- Efficient transfers using integrated μ DMA
 - Dual-buffer (ring) or linked-list (chained) descriptors
 - Round-robin or fixed priority arbitration between TX and RX
 - Descriptors support transfer blocks size up to 8KB
 - Programmable interrupts for flexible system implementation
- Physical media manipulation
 - MDI/MDI-X cross-over support
 - Register-programmable transmit amplitude
 - Automatic polarity correction and 10BASE-T signal reception

6.5.6.2 Controller Area Network (CAN)

CAN is a multicast shared serial-bus standard for connecting electronic control units (ECUs). CAN was specifically designed to be robust in electromagnetically noisy environments and can use a differential balanced line like RS-485 or twisted-pair wire. Originally created for automotive purposes, it is now used in many embedded control applications (for example, industrial or medical). Bit rates up to 1 Mbps are possible at network lengths below 40 meters. Decreased bit rates allow longer network distances (for example, 125 kbps at 500 m).

A transmitter sends a message to all CAN nodes (broadcasting). Each node decides on the basis of the identifier received whether it should process the message. The identifier also determines the priority that the message enjoys in competition for bus access. Each CAN message can transmit from 0 to 8 bytes of user information.

Each of the two CAN units includes the following features:

- CAN protocol version 2.0 part A/B
- Bit rates up to 1 Mbps
- 32 message objects with individual identifier masks
- Maskable interrupt
- Disable Automatic Retransmission mode for Time-Triggered CAN (TTCAN) applications
- Programmable loopback mode for self-test operation
- Programmable FIFO mode enables storage of multiple message objects
- Gluelessly attaches to an external CAN transceiver through the CANnTX and CANnRX signals

6.5.6.3 Universal Serial Bus (USB)

USB is a serial bus standard designed to allow connection and disconnection of peripherals using a standardized interface without rebooting the system.

One USB controller supports high-speed and full-speed multiple-point communications and complies with the USB 2.0 standard for high-speed function. The USB controller can have three configurations: USB device, USB host, and USB OTG (negotiated on-the-go as host or device when connected to other USB-enabled systems). Support for full-speed communication is provided by using the integrated USB PHY or optionally, a high-speed ULPI can communicate to an external PHY.

The USB module has the following features:

- Complies with USB-IF (Implementer's Forum) certification standards
- USB 2.0 high-speed (480 Mbps) operation with the integrated ULPI communicating with an external PHY
- Link power-management support that uses link-state awareness to reduce power usage
- Four transfer types: control, interrupt, bulk, and isochronous
- 16 endpoints
 - 1 dedicated control IN endpoint and 1 dedicated control OUT endpoint
 - 7 configurable IN endpoints and 7 configurable OUT endpoints

- 4KB of dedicated endpoint memory: one endpoint may be defined for double-buffered 1023-byte isochronous packet size
- VBUS droop detection and interrupt
- Integrated USB DMA with bus master capability
 - Up to eight RX endpoint channels and up to eight TX endpoint channels are available.
 - Each channel can be separately programmed to operate in different modes.
 - Incremental burst transfers of 4, 8, 16, or unspecified length supported

6.5.6.4 Universal Asynchronous Receiver/Transmitter (UART)

A UART is an integrated circuit used for RS-232C serial communications, containing a transmitter (parallel-to-serial converter) and a receiver (serial-to-parallel converter), each clocked separately.

Eight fully programmable 16C550-type UARTs are integrated. Although the functionality is similar to a 16C550 UART, this UART design is not register compatible. The UART can generate individually masked interrupts from the RX, TX, modem flow control, modem status, and error conditions. The module generates one combined interrupt when any of the interrupts are asserted and are unmasked.

The UARTs have the following features:

- Programmable baud-rate generator allowing speeds up to 7.5 Mbps for regular speed (divide by 16) and 15 Mbps for high speed (divide by 8)
- Separate 16x8 transmit (TX) and receive (RX) FIFOs to reduce CPU interrupt service loading
- Programmable FIFO length, including a 1-byte-deep operation providing conventional double-buffered interface
- FIFO trigger levels of 1/8, 1/4, 1/2, 3/4, and 7/8
- Standard asynchronous communication bits for start, stop, and parity
- Line-break generation and detection
- Fully programmable serial interface characteristics
 - 5, 6, 7, or 8 data bits
 - Even, odd, stick, or no-parity bit generation/detection
 - 1 or 2 stop bit generation
- IrDA serial-IR (SIR) encoder and decoder providing
 - Programmable use of IrDA Serial Infrared (SIR) or UART I/O
 - Support of IrDA SIR encoder and decoder functions for data rates up to 115.2 kbps half-duplex
 - Support of normal 3/16 and low-power (1.41 to 2.23 μ s) bit durations
 - Programmable internal clock generator enabling division of reference clock by 1 to 256 for low-power mode bit duration
- Support for communication with ISO 7816 smart cards
- Modem functionality available on the following UARTs:
 - UART0 (modem flow control and modem status)
 - UART1 (modem flow control and modem status)
 - UART2 (modem flow control)
 - UART3 (modem flow control)
 - UART4 (modem flow control)
- EIA-485 9-bit support
- Standard FIFO-level and end-of-transmission interrupts

- Efficient transfers using μ DMA
 - Separate channels for transmit and receive
 - Receive single request asserted when data is in the FIFO; burst request asserted at programmed FIFO level
 - Transmit single request asserted when there is space in the FIFO; burst request asserted at programmed FIFO level
- The Global Alternate Clock (ALTCLK) resource or System Clock (SYSCLK) can be used to generate the baud clock

6.5.6.5 Inter-Integrated Circuit (I²C)

The I²C bus provides bidirectional data transfer through a 2-wire design (a serial data line SDA and a serial clock line SCL). The I²C bus interfaces to external I²C devices such as serial memory (RAMs and ROMs), networking devices, LCDs, tone generators, and so on. The I²C bus can also be used for system testing and diagnostic purposes in product development and manufacture.

Each device on the I²C bus can be designated as either a master or a slave. The I2C module supports both sending and receiving data as either a master or a slave and can operate simultaneously as both a master and a slave. Both the I²C master and slave can generate interrupts.

The I2C modules include the following features:

- Devices on the I²C bus can be designated as either a master or a slave
 - Supports both transmitting and receiving data as either a master or a slave
 - Supports simultaneous master and slave operation
- Four I²C modes
 - Master transmit
 - Master receive
 - Slave transmit
 - Slave receive
- Two 8-entry FIFOs for receive and transmit data
 - FIFOs can be independently assigned to master or slave
- Four transmission speeds:
 - Standard (100 kbps)
 - Fast-mode (400 kbps)
 - Fast-mode plus (1 Mbps)
 - High-speed mode (3.33 Mbps)
- Glitch suppression
- SMBus support through software
 - Clock low time-out interrupt
 - Dual slave address capability
 - Quick command capability
- Master and slave interrupt generation
 - Master generates interrupts when a transmit or receive operation completes (or aborts due to an error)
 - Slave generates interrupts when data has been transferred or requested by a master or when a START or STOP condition is detected
- Master with arbitration and clock synchronization, multiple-master support, and 7-bit addressing mode
- Efficient transfers using μ DMA
 - Separate channels for transmit and receive
 - Ability to execute single data transfers or burst data transfers using the RX and TX FIFOs in the I²C

6.5.6.6 Quad Synchronous Serial Interface (QSSI)

QSSI is a bidirectional communications interface that converts data between parallel and serial. The QSSI module performs serial-to-parallel conversion on data received from a peripheral device and performs parallel-to-serial conversion on data transmitted to a peripheral device. The QSSI module can be configured as either a master or slave device. As a slave device, the QSSI module can also be configured to disable its output, which allows a master device to be coupled with multiple slave devices. The TX and RX paths are buffered with separate internal FIFOs.

The QSSI module also includes a programmable bit rate clock divider and prescaler to generate the output serial clock derived from the input clock of the QSSI module. Bit rates are generated based on the input clock, and the maximum bit rate is determined by the connected peripheral.

The four QSSI modules each support the following features:

- Four QSSI channels with advanced, bi-SSSI, and quad-SSSI functionality
- Programmable interface operation for Freescale SPI or TI synchronous serial interfaces in legacy mode. Support for Freescale interface in Bi- and Quad-SSSI mode.
- Master or slave operation
- Programmable clock bit rate and prescaler
- Separate transmit and receive FIFOs, each 16 bits wide and 8 locations deep
- Programmable data frame size from 4 to 16 bits
- Internal loopback test mode for diagnostic/debug testing
- Standard FIFO-based interrupts and end-of-transmission interrupt
- Efficient transfers using μ DMA
 - Separate channels for transmit and receive
 - Receive single request asserted when data is in the FIFO; burst request asserted when FIFO contains four entries
 - Transmit single request asserted when there is space in the FIFO; burst request asserted when four or more entries are available to be written in the FIFO
 - Maskable μ DMA interrupts for receive and transmit complete
- Global alternate clock (ALTCLK) resource or system clock (SYSCLK) can be used to generate baud clock.

6.5.7 System Integration

A variety of standard system functions are integrated into the device, including:

- Direct memory access (DMA) controller (see [节 6.5.7.1](#))
- System control and clocks including on-chip precision 16-MHz oscillator (see [节 6.5.7.2](#))
- Eight 32-bit timers (each timer can be configured as two 16-bit timers) (see [节 6.5.7.3](#))
- Lower-power battery-backed Hibernation module (see [节 6.5.7.5](#))
- RTC in Hibernation module
- Two watchdog timers (see [节 6.5.7.6](#))
 - One timer runs off the main oscillator.
 - One timer runs off the precision internal oscillator.
- 90 GPIOs, depending on configuration (see [节 6.5.7.7](#))
 - Highly flexible pin multiplexing allows use as GPIO or one of several peripheral functions.
 - GPIOs are independently configurable to 2-, 4-, 8-, 10-, or 12-mA drive capability.
 - Up to 4 GPIOs can have 18-mA drive capability.

6.5.7.1 Direct Memory Access (DMA)

The DMA controller is known as micro-DMA (μ DMA). The μ DMA controller provides a way to offload data transfer tasks from the Cortex-M4F processor, allowing for more efficient use of the processor and the available bus bandwidth. The μ DMA controller can perform transfers between memory and peripherals. It has dedicated channels for each supported on-chip module and can be programmed to automatically perform transfers between peripherals and memory as the peripheral is ready to transfer more data. The μ DMA controller provides the following features:

- Arm PrimeCell 32-channel configurable μ DMA controller
- Support for memory-to-memory, memory-to-peripheral, and peripheral-to-memory in multiple transfer modes
 - Basic for simple transfer scenarios
 - Ping-pong for continuous data flow
 - Scatter-gather for a programmable list of up to 256 arbitrary transfers initiated from one request
- Highly flexible and configurable channel operation
 - Independently configured and operated channels
 - Dedicated channels for supported on-chip modules
 - Flexible channel assignments
 - One channel each for receive and transmit path for bidirectional modules
 - Dedicated channel for software-initiated transfers
 - Per-channel configurable priority scheme
 - Optional software-initiated requests for any channel
- Two levels of priority
- Design optimizations for improved bus access performance between μ DMA controller and the processor core
 - μ DMA controller access is subordinate to core access
 - RAM striping
 - Peripheral bus segmentation
- Data sizes of 8, 16, and 32 bits
- Transfer size is programmable in binary steps from 1 to 1024
- Source and destination address increment size of byte, halfword, word, or no increment
- Maskable peripheral requests
- Interrupt on transfer completion, with a separate interrupt per channel

Each DMA channel has up to nine possible assignments that are selected using the DMA Channel Map Select n (DMACHMAPn) registers with 4-bit assignment fields for each μ DMA channel.

表 6-2 lists the μ DMA channel mapping. The Encoding column lists the encoding for the respective DMACHMAPn bit field. Encodings 0x9 to 0xF are reserved. The Type column indicates if a particular peripheral uses a single request (S), burst request (B), or either (SB).

注

Channels or encodings marked as Reserved cannot be used for μ DMA transfers. Channels designated in the table as only "Software" are dedicated software channels. When only one software request is required in an application, dedicated software channels can be used. If multiple software requests in code are required, then peripheral channel software requests should be used for proper μ DMA completion acknowledgement.

表 6-2. μ DMA Channel Assignments

Channel	Encoding																	
	0		1		2		3		4		5		6		7		8	
	Peripheral	Type	Peripheral	Type	Peripheral	Type	Peripheral	Type	Peripheral	Type	Peripheral	Type	Peripheral	Type	Peripheral	Type	Peripheral	Type
0	Reserved	–	UART2 RX	SB	Reserved	–	GPTimer 4A	B	Reserved	–	Reserved	–	I2C0 RX	SB	Reserved	–	Reserved	–
1	Reserved	–	UART2 TX	SB	Reserved	–	GPTimer 4B	B	Reserved	–	Reserved	–	I2C0 TX	SB	Reserved	–	Reserved	–
2	Reserved	–	GPTimer 3A	B	Reserved	–	Reserved	–	Reserved	–	Reserved	–	I2C1RX	SB	Reserved	–	Reserved	–
3	Reserved	–	GPTimer 3B	B	Reserved	–	Software	S	Reserved	–	Reserved	–	I2C1 TX	SB	Reserved	–	Reserved	–
4	Reserved	–	GPTimer 2A	B	Reserved	–	GPIO A	B	Reserved	–	SHA/MD5 0 Cin	B	I2C2 RX	SB	Reserved	–	Reserved	–
5	Reserved	–	GPTimer 2B	B	Reserved	–	GPIO B	B	Reserved	–	SHA/MD5 0 Din	B	I2C2 TX	SB	Reserved	–	Reserved	–
6	Reserved	–	GPTimer 2A	B	UART5 RX	SB	GPIO C	B	I2C0 RX	SB	SHA/MD5 0 Cout	B	Reserved	–	Reserved	–	Reserved	–
7	Reserved	–	GPTimer 2B	B	UART5 TX	SB	GPIO D	B	I2C0 TX	SB	Reserved	–	Reserved	–	Reserved	–	Reserved	–
8	UART0 RX	SB	UART1 RX	SB	Reserved	–	GPTimer 5A	B	I2C1RX	SB	Reserved	–	Reserved	–	Reserved	–	Reserved	–
9	UART0 TX	SB	UART1 TX	SB	Reserved	–	GPTimer 5B	B	I2C1 TX	SB	Reserved	–	Reserved	–	Reserved	–	Reserved	–
10	SSIO RX	SB	SSI1 RX	SB	UART6 RX	SB	Reserved	–	I2C2 RX	SB	Reserved	–	Reserved	–	GPTimer 6A	B	Reserved	–
11	SSIO TX	SB	SSI1 TX	SB	UART6 TX	SB	Reserved	–	I2C2 TX	SB	Reserved	–	Reserved	–	GPTimer 6B	B	Reserved	–
12	Reserved	–	UART2 RX	SB	SSI2 RX	SB	Reserved	–	GPIO K	B	AES0 Cin	B	Reserved	–	GPTimer 7A	B	Reserved	–
13	Reserved	–	UART2 TX	SB	SSI2 TX	SB	Reserved	–	GPIO L	B	AES0 Cout	B	Reserved	–	GPTimer 7B	B	Reserved	–
14	ADC0 SS0	SB	GPTimer 2A	B	SSI3 RX	SB	GPIO E	B	GPIO M	B	AES0 Din	B	Reserved	–	Reserved	–	Reserved	–
15	ADC0 SS1	SB	GPTimer 2B	B	SSI3 TX	SB	GPIO F	B	GPIO N	B	AES0 Dout	B	Reserved	–	Reserved	–	Reserved	–
16	ADC0 SS2	SB	Reserved	–	UART3 RX	SB	Reserved	–	GPIO P	B	Reserved	–	Reserved	–	Reserved	–	Reserved	–
17	ADC0 SS3	SB	Reserved	–	UART3 TX	SB	Reserved	–	Reserved	–	Reserved	–	Reserved	–	Reserved	–	Reserved	–
18	GPTimer 0A	B	GPTimer 1A	B	UART4 RX	SB	GPIO B	B	I2C3 RX	SB	Reserved	–	Reserved	–	Reserved	–	Reserved	–
19	GPTimer 0B	B	GPTimer 1B	B	UART4 TX	SB	GPIO G	B	I2C3 TX	SB	Reserved	–	Reserved	–	Reserved	–	Reserved	–
20	GPTimer 1A	B	EPIO RX Software	B	UART7 RX	SB	GPIO H	B	I2C4 RX	SB	DES0 Cin	B	Reserved	–	Reserved	–	Reserved	–
21	GPTimer 1B	B	EPIO TX Software	B	UART7 TX	SB	GPIO J	B	I2C4 TX	SB	DES0 Din	B	Reserved	–	Reserved	–	Reserved	–
22	UART1 RX	SB	Software	B	Reserved	–	Software	B	I2C5 RX	SB	DES0 Dout	B	Reserved	–	Reserved	–	I2C8 RX	B
23	UART1 TX	SB	Software	B	Reserved	–	Software	B	I2C5 TX	SB	Reserved	–	Reserved	–	Reserved	–	I2C8 TX	B
24	SSI1 RX	SB	ADC1 SS0	SB	Reserved	–	Reserved	–	GPIO Q	B	Reserved	–	Reserved	–	Reserved	–	I2C9 RX	B
25	SSI1 TX	SB	ADC1 SS1	SB	Reserved	–	Reserved	–	Reserved	–	Reserved	–	Reserved	–	Reserved	–	I2C9 TX	B

表 6-2. μ DMA Channel Assignments (continued)

Channel	Encoding																	
	0		1		2		3		4		5		6		7		8	
	Peripheral	Type	Peripheral	Type	Peripheral	Type	Peripheral	Type	Peripheral	Type	Peripheral	Type	Peripheral	Type	Peripheral	Type	Peripheral	Type
26	Software	B	ADC1 SS2	SB	Reserved	–	Reserved	–	Reserved	–	Reserved	–	Reserved	–	Reserved	–	I2C6 RX	B
27	Software	B	ADC1 SS3	SB	Reserved	–	Reserved	–	Reserved	–	Reserved	–	Reserved	–	Reserved	–	I2C6 TX	B
28	Reserved	–	Reserved	–	Reserved	–	Reserved	–	Reserved	–	Reserved	–	Reserved	–	Reserved	–	I2C7 RX	B
29	Reserved	–	Reserved	–	Reserved	–	Reserved	–	Reserved	–	Reserved	–	Reserved	–	Reserved	–	I2C7 TX	B
30	Software	B	Software	B	Reserved	–	Software	B	Reserved	–	Reserved	–	Reserved	–	EPI0 RX	B	Reserved	–
31	Reserved	–	Reserved	–	Reserved	–	Reserved	B	Reserved	–	Reserved	–	Reserved	–	EPI0 TX	B	Reserved	–

6.5.7.2 System Control and Clocks

System control determines the overall operation of the device. It provides information about the device, controls power-saving features, controls the clocking of the device and individual peripherals, and handles reset detection and reporting.

- Device identification information: version, part number, SRAM size, flash memory size, and so on
- Power control
 - On-chip fixed low dropout (LDO) voltage regulator
 - Hibernation module manages the power-up and power-down 3.3-V sequencing and control for the core digital logic and analog circuits
 - Low-power options for MCU: sleep and deep-sleep modes with clock gating
 - Low-power options for on-chip modules: software controls shutdown of individual peripherals and memory
 - 3.3-V supply brownout detection and reporting through interrupt or reset
- Multiple clock sources for the system clock. The MCU is clocked by the system clock (SYSCLK) that is distributed to the processor and integrated peripherals after clock gating. The SYSCLK frequency is based on the frequency of the clock source and a divisor factor. A PLL is provided for the generation of system clock frequencies in excess of the reference clock provided. The reference clocks for the PLL are the PIOSC and the main crystal oscillator. The following clock sources are provided to the MCU:
 - 16-MHz precision oscillator (PIOSC)
 - Main oscillator (MOSC): A frequency-accurate clock source by one of two means: an external single-ended clock source is connected to the OSC0 input pin, or an external crystal is connected across the OSC0 input and OSC1 output pins.
 - Low-frequency internal oscillator (LFIOSC): On-chip resource used during power-saving modes.
 - Hibernate RTC oscillator (RTCOSC): A clock that can be configured to be the 32.768-kHz external oscillator source from the HIB module or the HIB low-frequency clock source (HIB LFIOSC), which is in the HIB module.
- Flexible reset sources
 - Power-on reset (POR)
 - Reset pin assertion
 - Brownout reset (BOR) detector alerts to system power drops
 - Software reset
 - Watchdog timer reset
 - Hibernation module event
 - MOSC failure
- 128-bit unique identifier for individual device identification

6.5.7.3 Programmable Timers

Programmable timers can be used to count or time external events that drive the Timer input pins. Each 16- or 32-bit General-Purpose Timer Module (GPTM) block provides two 16-bit timers/counters that can be configured to operate independently as timers or event counters. These two timers/counters can also be configured to operate as one 32-bit timer or one 32-bit RTC. Timers can also be used to trigger analog-to-digital conversions and DMA transfers.

The GPTM contains eight 16- or 32-bit GPTM blocks with the following functional options:

- Operating modes
 - 16- or 32-bit programmable one-shot timer
 - 16- or 32-bit programmable periodic timer
 - 16-bit general-purpose timer with an 8-bit prescaler
 - 32-bit RTC when using an external 32.768-kHz clock as the input
 - 16-bit input-edge count- or time-capture modes with an 8-bit prescaler
 - 16-bit PWM mode with an 8-bit prescaler and software-programmable output inversion of the PWM signal
- Count up or down
- Sixteen 16- or 32-bit capture/compare PWM (CCP) pins
- Daisy-chaining of timer modules lets one timer initiate multiple timing events
- Timer synchronization lets selected timers start counting on the same clock cycle
- ADC event trigger
- User-enabled stalling when the MCU asserts the CPU halt flag during debug (excluding RTC mode)
- Can determine the elapsed time between the assertion of the timer interrupt and entry into the ISR
- Efficient transfers using μ DMA
 - Dedicated channel for each timer
 - Burst request generated on timer interrupt

6.5.7.4 Capture Compare PWM (CCP) Pins

CCP pins can be used by the General-Purpose Timer module to time or count external events using the CCP pin as an input. Alternatively, the GPTM can generate a simple PWM output on the CCP pin.

The 16/32-bit CCP pins can be programmed to operate in the following modes:

- Capture: The GP timer is incremented or decremented by programmed events on the CCP input. The GP timer captures and stores the current timer value when a programmed event occurs.
- Compare: The GP timer is incremented or decremented by programmed events on the CCP input. The GP timer compares the current value with a stored value and generates an interrupt when a match occurs.
- PWM: The GP timer is incremented or decremented by the system clock. A PWM signal is generated based on a match between the counter value and a value stored in a match register and is output on the CCP pin.

6.5.7.5 Hibernation (HIB) Module

The HIB module provides logic to switch power off to the main processor and peripherals and to wake on external or time-based events. The HIB module includes power-sequencing logic and has the following features:

- 32-bit RTC with 1/32768-second resolution and a 15-bit subseconds counter
 - 32-bit RTC seconds match register and a 15-bit subseconds match for timed wakeup and interrupt generation with 1/32768-second resolution
 - RTC predivider trim for making fine adjustments to the clock rate
- Hardware calendar function
 - Year, month, day, day of week, hours, minutes, and seconds
 - Four-year leap compensation
 - 24-hour or AM and PM configuration
- Two mechanisms for power control
 - System power control using a discrete external regulator
 - On-chip power control using internal switches under register control
- V_{DD} supplies power when valid, even if $V_{BAT} > V_{DD}$

- Dedicated pin for wake using an external signal
- Can configure the external reset ($\overline{\text{RST}}$) pin or up to four GPIO port pins as wake sources, with programmable wake level
- Tamper functionality
 - Support for four tamper inputs
 - Configurable level, weak pullup, and glitch filter
 - Configurable tamper event response
 - Logging of up to four tamper events
 - Optional BBRAM erase on tamper detection
 - Tamper detection and wake-from-hibernate capability
 - Hibernation clock input failure detect with a switch to the internal oscillator on detection
- RTC operational and hibernation memory valid as long as V_{DD} or V_{BAT} is valid
- Low-battery detection, signaling, and interrupt generation, with optional wake on low battery
- GPIO pin state can be retained during hibernation
- Clock source from an internal low-frequency oscillator (HIB LFIOOSC) or a 32.768-kHz external crystal or oscillator
- Sixteen 32-bit words of battery-backed memory to save state during hibernation
- Programmable interrupts for:
 - RTC match
 - External wake
 - Low battery

6.5.7.6 Watchdog Timers

A watchdog timer is used to regain control when a system has failed due to a software error or to the failure of an external device to respond in the expected way. The watchdog timer can generate an interrupt, a nonmaskable interrupt, or a reset when a time-out value is reached. In addition, the watchdog timer is Arm FIRM-compliant and can be configured to generate an interrupt to the MCU on its first time-out, and to generate a reset signal on its second time-out. After the watchdog timer has been configured, the lock register can be written to prevent inadvertently altering the timer configuration.

Two watchdog timer modules are supported: Watchdog Timer 0 uses the system clock for its timer clock; Watchdog Timer 1 uses the PIOSC as its timer clock. The watchdog timer module has the following features:

- 32-bit down counter with a programmable load register
- Separate watchdog clock with an enable
- Programmable interrupt generation logic with interrupt masking and optional NMI function
- Lock register protection from runaway software
- Reset generation logic with an enable/disable
- User-enabled stalling when the MCU asserts the CPU Halt flag during debug

6.5.7.7 Programmable GPIOs

General-purpose input/output (GPIO) pins offer flexibility for a variety of connections. The GPIO module is composed of 15 physical GPIO blocks, each corresponding to an individual GPIO port. The GPIO module is FIRM-compliant (compliant to the Arm Foundation IP for Real-Time MCUs specification) and supports 0 to 90 programmable I/O pins. The number of GPIOs available depends on the peripherals being used.

- Up to 90 GPIOs, depending on configuration
- Highly flexible pin multiplexing allows use as GPIO or one of several peripheral functions
- 3.3-V tolerant in input configuration

- Advanced high-performance bus (AHB) accesses all ports:
 - Ports A to H, K to N, P, and Q
- Fast toggle capable of a change every clock cycle for ports on AHB
- Programmable control for GPIO interrupts
 - Interrupt generation masking
 - Edge-triggered on rising, falling, or both
 - Level-sensitive on high or low values
 - Per-pin interrupts available on port P and port Q
- Bit masking in both read and write operations through address lines
- Can be used to initiate an ADC sample sequence or a μ DMA transfer
- Pin state can be retained during hibernation mode; pins on port P can be programmed to wake on level in hibernation mode
- Pins configured as digital inputs are Schmitt triggered
- Programmable control for GPIO pad configuration
 - Weak pullup or pulldown resistors
 - 2-, 4-, 6-, 8-, 10-, or 12-mA pad drive for digital communication; up to four pads can sink 18-mA for high-current applications
 - Slew rate control for 8-, 10-, and 12-mA pad drive
 - Open-drain enables
 - Digital-input enables

6.5.8 Advanced Motion Control

The motion control functions that are integrated into the device support the following features:

- Eight advanced PWM outputs for motion and energy applications
- Four fault inputs to promote low-latency shutdown
- One quadrature encoder input (QEI)

The following sections provides more detail on these motion control functions.

6.5.8.1 Pulse Width Modulation (PWM)

PWM is a powerful technique for digitally encoding analog signal levels. High-resolution counters are used to generate a square wave, and the duty cycle of the square wave is modulated to encode an analog signal. Typical applications include switching power supplies and motor control.

One PWM module is included, with four PWM generator blocks and a control block, for a total of eight PWM outputs. Each PWM generator block contains one timer (16-bit down or up/down counter), two comparators, a PWM signal generator, a dead-band generator, and an interrupt or ADC-trigger selector.

Each PWM generator block produces two PWM signals that can be either independent signals or a pair of complementary signals with dead-band delays inserted.

Each PWM generator has the following features:

- Four fault-condition handling inputs to quickly provide low-latency shutdown and prevent damage to the motor being controlled
- One 16-bit counter
 - Runs in down or up/down mode
 - Output frequency controlled by a 16-bit load value
 - Synchronized load value updates
 - Produces output signals at zero and load value

- Two PWM comparators
 - Synchronized comparator value updates
 - Produces output signals on match
- PWM signal generator
 - Output PWM signal is constructed based on actions taken as a result of the counter and PWM comparator output signals.
 - Produces two independent PWM signals
- Dead-band generator
 - Produces two PWM signals with programmable dead-band delays suitable for driving a half-H bridge
 - Can be bypassed, leaving input PWM signals unmodified
- Can initiate an ADC sample sequence

The control block determines the polarity of the PWM signals and which signals are passed through to the pins. The output of the PWM generation blocks are managed by the output control block before being passed to the device pins. The PWM control block has the following options:

- PWM output enable of each PWM signal
- Optional output inversion of each PWM signal (polarity control)
- Optional fault handling for each PWM signal
- Synchronization of timers in the PWM generator blocks
- Synchronization of timer/comparator updates across the PWM generator blocks
- Extended PWM synchronization of timer/comparator updates across the PWM generator blocks
- Interrupt status summary of the PWM generator blocks
- Extended PWM fault handling, with multiple fault signals, programmable polarities, and filtering
- PWM generators can be operated independently or synchronized with other generators

6.5.8.2 Quadrature Encoder With Index (QEI) Module

A quadrature encoder, also known as a 2-channel incremental encoder, converts linear displacement into a pulse signal. By monitoring both the number of pulses and the relative phase of the two signals, the position, direction of rotation, and speed can be tracked. In addition, a third channel, or index signal, can be used to reset the position counter. The QEI module interprets the code produced by a quadrature encoder wheel to integrate position over time and determine direction of rotation. In addition, it can capture a running estimate of the velocity of the encoder wheel. The input frequency of the QEI inputs may be as high as 1/4 of the system frequency (for example, 30 MHz for a 120-MHz system).

One QEI module provides control of one motor with the following features:

- Position integrator that tracks the encoder position
- Programmable noise filter on the inputs
- Velocity capture using built-in timer
- The input frequency of the QEI inputs may be as high as 1/4 of the system frequency (for example, 12.5 MHz for a 50-MHz system)
- Interrupt generation on:
 - Index pulse
 - Velocity-timer expiration
 - Direction change
 - Quadrature error detection

6.5.9 Analog

Integrated analog functions include:

- Two 12-bit ADCs with a total of 20 analog input channels and each with a sample rate of 2 Msps (see [节 6.5.9.1](#))
- Three analog comparators (see [节 6.5.9.2](#))
- On-chip voltage regulator

6.5.9.1 ADC

An ADC is a peripheral that converts a continuous analog voltage to a discrete digital number. The ADC module features 12-bit conversion resolution and supports 20 input channels plus an internal temperature sensor. Four buffered sample sequencers allow rapid sampling of up to 20 analog input sources without controller intervention. Each sample sequencer provides flexible programming with fully configurable input source, trigger events, interrupt generation, and sequencer priority. Each ADC module has a digital comparator function that lets the conversion value be sent to a comparison unit that provides eight digital comparators.

Both ADC modules support the following features:

- 20 shared analog input channels
- 12-bit precision ADC
- Single-ended and differential-input configurations
- On-chip internal temperature sensor
- Maximum sample rate of two million samples/second
- Optional, programmable phase delay
- Sample and hold window programmability
- Four programmable sample conversion sequencers from one to eight entries long, with corresponding conversion result FIFOs
- Flexible trigger control
 - Controller (software)
 - Timers
 - Analog comparators
 - PWM
 - GPIO
- Hardware averaging of up to 64 samples
- Eight digital comparators
- Converter uses two external reference signals (VREFA+ and VREFA–) or VDDA and GNDA as the voltage reference
- Power and ground for the analog circuitry is separate from the digital power and ground
- Efficient transfers using μ DMA
 - Dedicated channel for each sample sequencer
 - ADC module uses burst requests for DMA
- Global Alternate Clock (ALTCLK) resource or System Clock (SYSCLK) can be used to generate ADC clock.

6.5.9.2 Analog Comparators

An analog comparator is a peripheral that compares two analog voltages and provides a logical output that signals the comparison result. The independent integrated analog comparators can be configured to drive an output or generate an interrupt or ADC event.

The comparator can provide its output to a device pin, acting as a replacement for an analog comparator on the board, or it can be used to signal the application via interrupts or triggers to the ADC to cause it to start capturing a sample sequence. The interrupt generation and ADC triggering logic is separate. This means, for example, that an interrupt can be generated on a rising edge and the ADC triggered on a falling edge.

Each analog comparator supports the following functions:

- Compare external pin input to external pin input or to internal programmable voltage reference
- Compare a test voltage against any one of the following voltages:
 - An individual external reference voltage
 - A shared single external reference voltage
 - A shared internal reference voltage

6.5.10 JTAG and Arm Serial Wire Debug

The Joint Test Action Group (JTAG) port is an IEEE standard that defines a Test Access Port (TAP) and Boundary Scan Architecture for digital integrated circuits and provides a standardized serial interface for controlling the associated test logic. The TAP, Instruction Register (IR), and Data Register (DR) can be used to test the interconnections of assembled printed circuit boards and obtain manufacturing information on the components. The JTAG port also provides a means of accessing and controlling design-for-test features such as I/O pin observation and control, scan testing, and debugging. TI replaces the Arm SW-DP and JTAG-DP with the Arm Serial Wire JTAG Debug Port (SWJ-DP) interface. The SWJ-DP interface combines the SWD and JTAG debug ports into one module. This module provides the standard JTAG debug and test functionality plus real-time access to system memory without halting the core or requiring any target resident code. The SWJ-DP interface has the following features:

- IEEE 1149.1-1990 compatible TAP controller
- Four-bit IR chain for storing JTAG instructions
- IEEE standard instructions: BYPASS, IDCODE, SAMPLE/PRELOAD, and EXTEST
- Arm additional instructions: APACC, DPACC, and ABORT
- Integrated Arm Serial Wire Debug (SWD)
 - Serial Wire JTAG Debug Port (SWJ-DP)
 - Flash Patch and Breakpoint (FPB) unit for implementing breakpoints
 - Data Watchpoint and Trace (DWT) unit for implementing watchpoints, trigger resources, and system profiling
 - Instrumentation Trace Macrocell (ITM) for support of printf-style debugging
 - Embedded Trace Macrocell (ETM) for instruction trace capture
 - Trace Port Interface Unit (TPIU) for bridging to a Trace Port Analyzer

6.5.11 Peripheral Memory Map

表 6-3 lists the address for each peripheral.

注

Within the memory map, attempts to read or write addresses in reserved spaces result in a bus fault. In addition, attempts to write addresses in the flash range also result in a bus fault.

表 6-3. Memory Map

START	END	DESCRIPTION	REGISTERS
0x4000.0000	0x4000.0FFF	Watchdog Timer 0	表 6-32
0x4000.1000	0x4000.1FFF	Watchdog Timer 1	表 6-32
0x4000.2000	0x4000.3FFF	Reserved	

表 6-3. Memory Map (continued)

START	END	DESCRIPTION	REGISTERS
0x4000.4000	0x4000.4FFF	GPIO Port A	表 6-17
0x4000.5000	0x4000.5FFF	GPIO Port B	表 6-17
0x4000.6000	0x4000.6FFF	GPIO Port C	表 6-17
0x4000.7000	0x4000.7FFF	GPIO Port D	表 6-17
0x4000.8000	0x4000.8FFF	SSI0	表 6-25
0x4000.9000	0x4000.9FFF	SSI1	表 6-25
0x4000.A000	0x4000.AFFF	SSI2	表 6-25
0x4000.B000	0x4000.BFFF	SSI3	表 6-25
0x4000.C000	0x4000.CFFF	UART0	表 6-30
0x4000.D000	0x4000.DFFF	UART1	表 6-30
0x4000.E000	0x4000.EFFF	UART2	表 6-30
0x4000.F000	0x4000.FFFF	UART3	表 6-30
0x4001.0000	0x4001.0FFF	UART4	表 6-30
0x4001.1000	0x4001.1FFF	UART5	表 6-30
0x4001.2000	0x4001.2FFF	UART6	表 6-30
0x4001.3000	0x4001.3FFF	UART7	表 6-30
0x4001.4000	0x4001.FFFF	Reserved	
0x4002.0000	0x4002.0FFF	I2C 0	表 6-20
0x4002.1000	0x4002.1FFF	I2C 1	表 6-20
0x4002.2000	0x4002.2FFF	I2C 2	表 6-20
0x4002.3000	0x4002.3FFF	I2C 3	表 6-20
0x4002.4000	0x4002.4FFF	GPIO Port E	表 6-17
0x4002.5000	0x4002.5FFF	GPIO Port F	表 6-17
0x4002.6000	0x4002.6FFF	GPIO Port G	表 6-17
0x4002.7000	0x4002.7FFF	GPIO Port H	表 6-17
0x4002.8000	0x4002.8FFF	PWM 0	表 6-23
0x4002.9000	0x4002.BFFF	Reserved	
0x4002.C000	0x4002.CFFF	QE10	表 6-24
0x4002.D000	0x4002.FFFF	Reserved	
0x4003.0000	0x4003.0FFF	16/32-bit Timer 0	表 6-18
0x4003.1000	0x4003.1FFF	16/32-bit Timer 1	表 6-18
0x4003.2000	0x4003.2FFF	16/32-bit Timer 2	表 6-18
0x4003.3000	0x4003.3FFF	16/32-bit Timer 3	表 6-18
0x4003.4000	0x4003.4FFF	16/32-bit Timer 4	表 6-18
0x4003.5000	0x4003.5FFF	16/32-bit Timer 5	表 6-18
0x4003.6000	0x4003.7FFF	Reserved	
0x4003.8000	0x4003.8FFF	ADC0	表 6-6
0x4003.9000	0x4003.9FFF	ADC1	表 6-6
0x4003.A000	0x4003.BFFF	Reserved	
0x4003.C000	0x4003.CFFF	Analog Comparator	表 6-8
0x4003.D000	0x4003.DFFF	GPIO Port J	表 6-17
0x4003.E000	0x4003.FFFF	Reserved	
0x4004.0000	0x4004.0FFF	CAN0 Controller	表 6-7
0x4004.1000	0x4004.1FFF	CAN1 Controller	表 6-7
0x4004.2000	0x4004.FFFF	Reserved	
0x4005.0000	0x4005.0FFF	USB	表 6-31
0x4005.1000	0x4005.7FFF	Reserved	

表 6-3. Memory Map (continued)

START	END	DESCRIPTION	REGISTERS
0x4005.8000	0x4005.8FFF	GPIO Port A (AHB aperture)	表 6-17
0x4005.9000	0x4005.9FFF	GPIO Port B (AHB aperture)	表 6-17
0x4005.A000	0x4005.AFFF	GPIO Port C (AHB aperture)	表 6-17
0x4005.B000	0x4005.BFFF	GPIO Port D (AHB aperture)	表 6-17
0x4005.C000	0x4005.CFFF	GPIO Port E (AHB aperture)	表 6-17
0x4005.D000	0x4005.DFFF	GPIO Port F (AHB aperture)	表 6-17
0x4005.E000	0x4005.EFFF	GPIO Port G (AHB aperture)	表 6-17
0x4005.F000	0x4005.FFFF	GPIO Port H (AHB aperture)	表 6-17
0x4006.0000	0x4006.0FFF	GPIO Port J (AHB aperture)	表 6-17
0x4006.1000	0x4006.1FFF	GPIO Port K (AHB aperture)	表 6-17
0x4006.2000	0x4006.2FFF	GPIO Port L (AHB aperture)	表 6-17
0x4006.3000	0x4006.3FFF	GPIO Port M (AHB aperture)	表 6-17
0x4006.4000	0x4006.4FFF	GPIO Port N (AHB aperture)	表 6-17
0x4006.5000	0x4006.5FFF	GPIO Port P (AHB aperture)	表 6-17
0x4006.6000	0x4006.6FFF	GPIO Port Q (AHB aperture)	表 6-17
0x4006.7000	0x400A.EFFF	Reserved	
0x400A.F000	0x400A.FFFF	EEPROM and Key Locker	表 6-12
0x400B.0000	0x400B.5FFF	Reserved	
0x400B.6000	0x400B.6FFF	Reserved	
0x400B.7000	0x400B.7FFF	Reserved	
0x400B.8000	0x400B.8FFF	I2C 8	表 6-20
0x400B.9000	0x400B.9FFF	I2C 9	表 6-20
0x400B.A000	0x400B.FFFF	Reserved	
0x400C.0000	0x400C.0FFF	I2C 4	表 6-20
0x400C.1000	0x400C.1FFF	I2C 5	表 6-20
0x400C.2000	0x400C.2FFF	I2C 6	表 6-20
0x400C.3000	0x400C.3FFF	I2C 7	表 6-20
0x400C.4000	0x400C.FFFF	Reserved	
0x400D.0000	0x400D.0FFF	EPI0	表 6-13
0x400D.1000	0x400D.FFFF	Reserved	
0x400E.0000	0x400E.0FFF	16/32-bit Timer 6	表 6-18
0x400E.1000	0x400E.1FFF	16/32-bit Timer 7	表 6-18
0x400E.2000	0x400E.BFFF	Reserved	
0x400E.C000	0x400E.CFFF	Ethernet Controller	表 6-14
0x400E.D000	0x400F.8FFF	Reserved	
0x400F.9000	0x400F.9FFF	System Exception	表 6-29
0x400F.A000	0x400F.BFFF	Reserved	
0x400F.C000	0x400F.CFFF	Hibernation	表 6-19
0x400F.D000	0x400F.DFFF	Flash Memory Control	表 6-16
0x400F.E000	0x400F.EFFF	System Control	表 6-28
0x400F.F000	0x400F.FFFF	μDMA	表 6-21
0x4010.0000	0x41FF.FFFF	Reserved	
0x4200.0000	0x43FF.FFFF	Bit-banded alias of 0x4000.0000 through 0x400F.FFFF	
0x4400.0000	0x4402.FFFF	Reserved	
0x4403.0000	0x4403.0FFF	CRC and Cryptographic Control	表 6-9
0x4403.1000	0x4403.1FFF	Reserved (4KB)	
0x4403.2000	0x4403.3FFF	Reserved (8KB)	

表 6-3. Memory Map (continued)

START	END	DESCRIPTION	REGISTERS
0x4403.4000	0x4403.5FFF	SHA/MD5	表 6-26
0x4403.6000	0x4403.7FFF	AES	表 6-4, 表 6-5
0x4403.8000	0x4403.9FFF	DES	表 6-10, 表 6-11
0x4403.A000	0x4403.EFFF	Reserved	
0x4403.F000	0x4403.FFFF	Reserved (4KB)	
0x4404.0000	0x4404.FFFF	Reserved (64KB)	
0x4405.0000	0x4405.0FFF	Reserved	
0x4405.1000	0x4405.3FFF	Reserved	
0x4405.4000	0x4405.4FFF	EPHY 0	表 6-15
0x4405.5000	0x5FFF.FFFF	Reserved	
0x6000.0000	0xDFFF.FFFF	EPI0 Mapped Peripheral and RAM	表 6-13

表 6-4. AES Registers

OFFSET	ACRONYM	REGISTER NAME
0x00C	AES_KEY2_5	AES Key 2_5
0x010	AES_KEY2_2	AES Key 2_2
0x014	AES_KEY2_3	AES Key 2_3
0x018	AES_KEY2_0	AES Key 2_0
0x01C	AES_KEY2_1	AES Key 2_1
0x020	AES_KEY1_6	AES Key 1_6
0x024	AES_KEY1_7	AES Key 1_7
0x028	AES_KEY1_4	AES Key 1_4
0x02C	AES_KEY1_5	AES Key 1_5
0x030	AES_KEY1_2	AES Key 1_2
0x034	AES_KEY1_3	AES Key 1_3
0x038	AES_KEY1_0	AES Key 1_0
0x03C	AES_KEY1_1	AES Key 1_1
0x40 to 0x4C	AES_IV_IN_0 to AES_IV_IN_3	AES Initialization Vector Input 0 to AES Initialization Vector Input 3
0x50	AES_CTRL	AES Control
0x54 to 0x58	AES_C_LENGTH_0 to AES_C_LENGTH_1	AES Crypto Data Length 0 to AES Crypto Data Length 1
0x5C	AES_AUTH_LENGTH	AES Authentication Data Length
0x60 to 0x6C	AES_DATA_IN_0 to AES_DATA_IN_3	AES Data R/W Plaintext/Ciphertext 0 to AES Data R/W Plaintext/Ciphertext 3
0x70 to 0x7C	AES_TAG_OUT_0 to AES_TAG_OUT_3	AES Hash Tag Out 0 to AES Hash Tag Out 3
0x80	AES_REVISION	AES IP Revision Identifier
0x84	AES_SYSCONFIG	AES System Configuration
0x88	AES_SYSSTATUS	AES System Status
0x8C	AES_IRQSTATUS	AES Interrupt Status
0x90	AES_IRQENABLE	AES Interrupt Enable
0x94	AES_DIRTYBITS	AES Dirty Bits

表 6-5. AES μ DMA Registers

OFFSET	ACRONYM	REGISTER NAME
0x20	AES_DMAIM	AES DMA Interrupt Mask
0x24	AES_DMARIS	AES DMA Raw Interrupt Status
0x28	AES_DMAMIS	AES DMA Masked Interrupt Status

表 6-5. AES μ DMA Registers (continued)

OFFSET	ACRONYM	REGISTER NAME
0x2C	AES_DMAIC	AES DMA Interrupt Clear

表 6-6. ADC Registers

OFFSET	ACRONYM	REGISTER NAME
0x0	ADCACTSS	ADC Active Sample Sequencer
0x4	ADCRIS	ADC Raw Interrupt Status
0x8	ADCIM	ADC Interrupt Mask
0xC	ADCISC	ADC Interrupt Status and Clear
0x10	ADCOSTAT	ADC Overflow Status
0x14	ADCEMUX	ADC Event Multiplexer Select
0x18	ADCUSTAT	ADC Underflow Status
0x1C	ADCTSSEL	ADC Trigger Source Select
0x20	ADCSSPRI	ADC Sample Sequencer Priority
0x24	ADCSPC	ADC Sample Phase Control
0x28	ADCPSSI	ADC Processor Sample Sequence Initiate
0x30	ADCSAC	ADC Sample Averaging Control
0x34	ADCDCISC	ADC Digital Comparator Interrupt Status and Clear
0x38	ADCCTL	ADC Control
0x40	ADCSSMUX0	ADC Sample Sequence Input Multiplexer Select 0
0x44	ADCSSCTL0	ADC Sample Sequence Control 0
0x48	ADCSSFIFO0	ADC Sample Sequence Result FIFO 0
0x4C	ADCSSFSTAT0	ADC Sample Sequence FIFO 0 Status
0x50	ADCSSOP0	ADC Sample Sequence 0 Operation
0x54	ADCSSDC0	ADC Sample Sequence 0 Digital Comparator Select
0x58	ADCSEMUX0	ADC Sample Sequence Extended Input Multiplexer Select 0
0x5C	ADCSSSTSH0	ADC Sample Sequence 0 Sample and Hold Time
0x60	ADCSSMUX1	ADC Sample Sequence Input Multiplexer Select 1
0x64	ADCSSCTL1	ADC Sample Sequence Control 1
0x068	ADCSSFIFO1	ADC Sample Sequence Result FIFO 1
0x06C	ADCSSFSTAT1	ADC Sample Sequence FIFO 1 Status
0x70	ADCSSOP1	ADC Sample Sequence 1 Operation
0x74	ADCSSDC1	ADC Sample Sequence 1 Digital Comparator Select
0x78	ADCSEMUX1	ADC Sample Sequence Extended Input Multiplexer Select 1
0x7C	ADCSSSTSH1	ADC Sample Sequence 1 Sample and Hold Time
0x080	ADCSSMUX2	ADC Sample Sequence Input Multiplexer Select 2
0x084	ADCSSCTL2	ADC Sample Sequence Control 2
0x088	ADCSSFIFO2	ADC Sample Sequence Result FIFO 2
0x08C	ADCSSFSTAT2	ADC Sample Sequence FIFO 2 Status
0x090	ADCSSOP2	ADC Sample Sequence 2 Operation
0x094	ADCSSDC2	ADC Sample Sequence 2 Digital Comparator Select
0x098	ADCSEMUX2	ADC Sample Sequence Extended Input Multiplexer Select 2
0x09C	ADCSSSTSH2	ADC Sample Sequence 2 Sample and Hold Time
0xA0	ADCSSMUX3	ADC Sample Sequence Input Multiplexer Select 3
0xA4	ADCSSCTL3	ADC Sample Sequence Control 3
0x0A8	ADCSSFIFO3	ADC Sample Sequence Result FIFO 3
0x0AC	ADCSSFSTAT3	ADC Sample Sequence FIFO 3 Status
0xB0	ADCSSOP3	ADC Sample Sequence 3 Operation

表 6-6. ADC Registers (continued)

OFFSET	ACRONYM	REGISTER NAME
0xB4	ADCSSDC3	ADC Sample Sequence 3 Digital Comparator Select
0xB8	ADCSEMUX3	ADC Sample Sequence Extended Input Multiplexer Select 3
0xBC	ADCSTSH3	ADC Sample Sequence 3 Sample and Hold Time
0xD00	ADCDCRIC	ADC Digital Comparator Reset Initial Conditions
0xE00 to 0xE1C	ADCDCCTL0 to ADCDCCTL7	ADC Digital Comparator Control 0 to ADC Digital Comparator Control 7
0xE40 to 0xE5C	ADCDCCMP0 to ADCDCCMP7	ADC Digital Comparator Range 0 to ADC Digital Comparator Range 7
0xFC0	ADCPP	ADC Peripheral Properties
0xFC4	ADPC	ADC Peripheral Configuration
0xFC8	ADCCC	ADC Clock Configuration

表 6-7. CAN Registers

OFFSET	ACRONYM	REGISTER NAME
0x0	CANCTL	CAN Control
0x4	CANSTS	CAN Status
0x8	CANERR	CAN Error Counter
0xC	CANBIT	CAN Bit Timing
0x10	CANINT	CAN Interrupt
0x14	CANTST	CAN Test
0x18	CANBRPE	CAN Baud Rate Prescaler Extension
0x20	CANIF1CRQ	CAN IF1 Command Request
0x24	CANIF1CMSK	CAN IF1 Command Mask
0x28	CANIF1MSK1	CAN IF1 Mask 1
0x2C	CANIF1MSK2	CAN IF1 Mask 2
0x30	CANIF1ARB1	CAN IF1 Arbitration 1
0x34	CANIF1ARB2	CAN IF1 Arbitration 2
0x38	CANIF1MCTL	CAN IF1 Message Control
0x3C	CANIF1DA1	CAN IF1 Data A1
0x40	CANIF1DA2	CAN IF1 Data A2
0x44	CANIF1DB1	CAN IF1 Data B1
0x48	CANIF1DB2	CAN IF1 Data B2
0x80	CANIF2CRQ	CAN IF2 Command Request
0x84	CANIF2CMSK	CAN IF2 Command Mask
0x88	CANIF2MSK1	CAN IF2 Mask 1
0x8C	CANIF2MSK2	CAN IF2 Mask 2
0x90	CANIF2ARB1	CAN IF2 Arbitration 1
0x94	CANIF2ARB2	CAN IF2 Arbitration 2
0x98	CANIF2MCTL	CAN IF2 Message Control
0x9C	CANIF2DA1	CAN IF2 Data A1
0xA0	CANIF2DA2	CAN IF2 Data A2
0xA4	CANIF2DB1	CAN IF2 Data B1
0xA8	CANIF2DB2	CAN IF2 Data B2
0x100	CANTXRQ1	CAN Transmission Request 1
0x104	CANTXRQ2	CAN Transmission Request 2
0x120	CANNWDA1	CAN New Data 1
0x124	CANNWDA2	CAN New Data 2
0x140	CANMSG1INT	CAN Message 1 Interrupt Pending
0x144	CANMSG2INT	CAN Message 2 Interrupt Pending

表 6-7. CAN Registers (continued)

OFFSET	ACRONYM	REGISTER NAME
0x160	CANMSG1VAL	CAN Message 1 Valid
0x164	CANMSG2VAL	CAN Message 2 Valid

表 6-8. Comparator Registers

OFFSET	ACRONYM	REGISTER NAME
0x0	ACMIS	Analog Comparator Masked Interrupt Status
0x4	ACRIS	Analog Comparator Raw Interrupt Status
0x8	ACINTEN	Analog Comparator Interrupt Enable
0x10	ACREFCTL	Analog Comparator Reference Voltage Control
0x20	ACSTAT0	Analog Comparator Status 0
0x24	ACCTL0	Analog Comparator Control 0
0x40	ACSTAT1	Analog Comparator Status 1
0x44	ACCTL1	Analog Comparator Control 1
0x60	ACSTAT2	Analog Comparator Status 2
0x64	ACCTL2	Analog Comparator Control 2
0xFC0	ACMPPP	Analog Comparator Peripheral Properties

表 6-9. CRC Registers

OFFSET	ACRONYM	REGISTER NAME
400h	CRCCTRL	CRC Control
410h	CRCSEED	CRC SEED/Context
414h	CRC DIN	CRC Data Input
418h	CRCRSLTPP	CRC Post Processing Result

表 6-10. DES Registers

OFFSET	ACRONYM	REGISTER NAME
0x00	DES_KEY3_L	DES Key 3 LSW for 192-Bit Key
0x04	DES_KEY3_H	DES Key 3 MSW for 192-Bit Key
0x08	DES_KEY2_L	DES Key 2 LSW for 128-Bit Key
0x0C	DES_KEY2_H	DES Key 2 MSW for 128-Bit Key
0x10	DES_KEY1_L	DES Key 1 LSW for 64-Bit Key
0x14	DES_KEY1_H	DES Key 1 MSW for 64-Bit Key
0x18	DES_IV_L	DES Initialization Vector
0x1C	DES_IV_H	DES Initialization Vector
0x20	DES_CTRL	DES Control
0x24	DES_LENGTH	DES Cryptographic Data Length
0x28	DES_DATA_L	DES LSW Data RW
0x2C	DES_DATA_H	DES MSW Data RW
0x30	DES_REVISION	DES Revision Number
0x34	DES_SYSCONFIG	DES System Configuration
0x38	DES_SYSSTATUS	DES System Status
0x3C	DES_IRQSTATUS	DES Interrupt Status
0x40	DES_IRQENABLE	DES Interrupt Enable
0x44	DES_DIRTYBITS	DES Dirty Bits

表 6-11. DES μ DMA Registers

OFFSET	ACRONYM	REGISTER NAME
0x30	DES_DMAIM	DES DMA Interrupt Mask
0x34	DES_DMARIS	DES DMA Raw Interrupt Status
0x38	DES_DMAMIS	DES DMA Masked Interrupt Status
0x3C	DES_DMAIC	DES DMA Interrupt Clear

表 6-12. EEPROM Registers

OFFSET	ACRONYM	REGISTER NAME
0x0	EESIZE	EEPROM Size Information
0x4	EEBLOCK	EEPROM Current Block
0x8	EEOFFSET	EEPROM Current Offset
0x10	EERDWR	EEPROM Read-Write
0x14	EERDWRINC	EEPROM Read-Write with Increment
0x18	EEDONE	EEPROM Done Status
0x1C	EESUPP	EEPROM Support Control and Status
0x20	EEUNLOCK	EEPROM Unlock
0x30	EEPROT	EEPROM Protection
0x34 to 0x3C	EEPASS0 to EEPASS2	EEPROM Password 0 to EEPROM Password 2
0x40	EEINT	EEPROM Interrupt
0x50	EEHIDE0	EEPROM Block Hide 0
0x54	EEHIDE1	EEPROM Block Hide 1
0x58	EEHIDE2	EEPROM Block Hide 2
0x80	EEDBGME	EEPROM Debug Mass Erase
0xFC0	EEPROMPP	EEPROM Peripheral Properties

表 6-13. EPI Registers

OFFSET	ACRONYM	REGISTER NAME
0x000	EPICFG	EPI Configuration
0x004	EPIBAUD	EPI Main Baud Rate
0x008	EPIBAUD2	EPI Main Baud Rate
0x010	EPISDRAMCFG	EPI SDRAM Configuration
0x010	EPIHB8CFG	EPI Host-Bus 8 Configuration
0x010	EPIHB16CFG	EPI Host-Bus 16 Configuration
0x010	EPIGPCFG	EPI General-Purpose Configuration
0x014	EPIHB8CFG2	EPI Host-Bus 8 Configuration 2
0x014	EPIHB16CFG2	EPI Host-Bus 16 Configuration 2
0x01C	EPIADDRMAP	EPI Address Map
0x020	EPIRSIZE0	EPI Read Size 0
0x024	EPIRADDR0	EPI Read Address 0
0x028	EPIRPSTD0	EPI Non-Blocking Read Data 0
0x030	EPIRSIZE1	EPI Read Size 1
0x034	EPIRADDR1	EPI Read Address 1
0x038	EPIRPSTD1	EPI Non-Blocking Read Data 1
0x060	EPISTAT	EPI Status
0x06C	EPIRFIFOCNT	EPI Read FIFO Count
0x70 to 0x8C	EPIREADFIFO0 to EPIREADFIFO7	EPI Read FIFO 0 to EPI Read FIFO 7
0x200	EPIFIFOLVL	EPI FIFO Level Selects
0x24	EPIWFIFOCNT	EPI Write FIFO Count

表 6-13. EPI Registers (continued)

OFFSET	ACRONYM	REGISTER NAME
0x28	EPIDMATXCNT	EPI DMA Transmit Count
0x210	EPIIM	EPI Interrupt Mask
0x214	EPIRIS	EPI Raw Interrupt Status
0x218	EPIMIS	EPI Masked Interrupt Status
0x21C	EPIEISC	EPI Error and Interrupt Status and Clear
0x308	EPIHB8CFG3	EPI Host-Bus 8 Configuration 3
0x308	EPIHB16CFG3	EPI Host-Bus 16 Configuration 3
0x30C	EPIHB8CFG4	EPI Host-Bus 8 Configuration 4
0x30C	EPIHB16CFG4	EPI Host-Bus 16 Configuration 4
0x310	EPIHB8TIME	EPI Host-Bus 8 Timing Extension
0x310	EPIHB16TIME	EPI Host-Bus 16 Timing Extension
0x314	EPIHB8TIME2	EPI Host-Bus 8 Timing Extension
0x314	EPIHB16TIME2	EPI Host-Bus 16 Timing Extension
0x318	EPIHB8TIME3	EPI Host-Bus 8 Timing Extension
0x318	EPIHB16TIME3	EPI Host-Bus 16 Timing Extension
0x31C	EPIHB8TIME4	EPI Host-Bus 8 Timing Extension
0x31C	EPIHB16TIME4	EPI Host-Bus 16 Timing Extension
0x360	EPIHBPSRAM	EPI Host-Bus PSRAM

表 6-14. Ethernet MAC (EMAC) Registers

OFFSET	ACRONYM	REGISTER NAME
0x0	EMACCFG	Ethernet MAC Configuration
0x4	EMACFRAMEFLTR	Ethernet MAC Frame Filter
0x8	EMACHASHTBLH	Ethernet MAC Hash Table High
0xC	EMACHASHTBLL	Ethernet MAC Hash Table Low
0x10	EMACMIIADDR	Ethernet MAC MII Address
0x14	EMACMIIDATA	Ethernet MAC MII Data Register
0x18	EMACFLOWCTL	Ethernet MAC Flow Control
0x1C	EMACVLANTG	Ethernet MAC VLAN Tag
0x24	EMACSTATUS	Ethernet MAC Status
0x28	EMACRWUFF	Ethernet MAC Remote Wake-Up Frame Filter
0x2C	EMACPMTCTLSTAT	Ethernet MAC PMT Control and Status
0x30	EMACLPICTLSTAT	LPI Control and Status
0x34	EMACLPITIMERCTRL	LPI Timers Control
0x38	EMACRIS	Ethernet MAC Raw Interrupt Status
0x3C	EMACIM	Ethernet MAC Interrupt Mask
0x40	EMACADDR0H	Ethernet MAC Address 0 High
0x44	EMACADDR0L	Ethernet MAC Address 0 Low Register
0x48	EMACADDR1H	Ethernet MAC Address 1 High
0x4C	EMACADDR1L	Ethernet MAC Address 1 Low
0x50	EMACADDR2H	Ethernet MAC Address 2 High
0x54	EMACADDR2L	Ethernet MAC Address 2 Low
0x58	EMACADDR3H	Ethernet MAC Address 3 High
0x5C	EMACADDR3L	Ethernet MAC Address 3 Low
0xDC	EMACWDOGTO	Ethernet MAC Watchdog Time-out
0x100	EMACMMCCTRL	Ethernet MAC MMC Control
0x104	EMACMMCRXRIS	Ethernet MAC MMC Receive Raw Interrupt Status

表 6-14. Ethernet MAC (EMAC) Registers (continued)

OFFSET	ACRONYM	REGISTER NAME
0x108	EMACMMCTXRIS	Ethernet MAC MMC Transmit Raw Interrupt Status
0x10C	EMACMMCRXIM	Ethernet MAC MMC Receive Interrupt Mask
0x110	EMACMMCTXIM	Ethernet MAC MMC Transmit Interrupt Mask
0x118	EMACTXCNTGB	Ethernet MAC Transmit Frame Count for Good and Bad Frames
0x14C	EMACTXCNTSCOL	Ethernet MAC Transmit Frame Count for Frames Transmitted After Single Collision
0x150	EMACTXCNTMCOL	Ethernet MAC Transmit Frame Count for Frames Transmitted After Multiple Collisions
0x164	EMACTXOCTCNTG	Ethernet MAC Transmit Octet Count Good
0x180	EMACRXCNTGB	Ethernet MAC Receive Frame Count for Good and Bad Frames
0x194	EMACRXCNTCRCERR	Ethernet MAC Receive Frame Count for CRC Error Frames
0x198	EMACRXCNTALGNERR	Ethernet MAC Receive Frame Count for Alignment Error Frames
0x1C4	EMACRXCNTGUNI	Ethernet MAC Receive Frame Count for Good Unicast Frames
0x584	EMACVLNINCREP	Ethernet MAC VLAN Tag Inclusion or Replacement
0x588	EMACVLANHASH	Ethernet MAC VLAN Hash Table
0x700	EMACTIMSTCTRL	Ethernet MAC Timestamp Control
0x704	EMACSUBSECINC	Ethernet MAC Sub-Second Increment
0x708	EMACTIMSEC	Ethernet MAC System Time - Seconds
0x70C	EMACTIMNANO	Ethernet MAC System Time - Nanoseconds
0x710	EMACTIMSECU	Ethernet MAC System Time - Seconds Update
0x714	EMACTIMNANO	Ethernet MAC System Time - Nanoseconds Update
0x718	EMACTIMADD	Ethernet MAC Timestamp Addend
0x71C	EMACTARGSEC	Ethernet MAC Target Time Seconds
0x720	EMACTARGNANO	Ethernet MAC Target Time Nanoseconds
0x724	EMACHWORDSEC	Ethernet MAC System Time-Higher Word Seconds
0x728	EMACTIMSTAT	Ethernet MAC Timestamp Status
0x72C	EMACPPSCTRL	Ethernet MAC PPS Control
0x760	EMACPPS0INTVL	Ethernet MAC PPS0 Interval
0x764	EMACPPS0WIDTH	Ethernet MAC PPS0 Width
0xC00	EMACDMABUSMOD	Ethernet MAC DMA Bus Mode
0xC04	EMACTXPOLL	Ethernet MAC Transmit Poll Demand
0xC08	EMACRXPOLLD	Ethernet MAC Receive Poll Demand
0xC0C	EMACRXDLADDR	Ethernet MAC Receive Descriptor List Address
0xC10	EMACTXDLADDR	Ethernet MAC Transmit Descriptor List Address
0xC14	EMACDMARIS	Ethernet MAC DMA Interrupt Status
0xC18	EMACDMAOPMODE	Ethernet MAC DMA Operation Mode
0xC1C	EMACDMAIM	Ethernet MAC DMA Interrupt Mask Register
0xC20	EMACMFBOC	Ethernet MAC Missed Frame and Buffer Overflow Counter
0xC24	EMACRXINTWDT	Ethernet MAC Receive Interrupt Watchdog Timer
0xC48	EMACHOSTXDESC	Ethernet MAC Current Host Transmit Descriptor
0xC4C	EMACHOSRXDESC	Ethernet MAC Current Host Receive Descriptor
0xC50	EMACHOSTXBA	Ethernet MAC Current Host Transmit Buffer Address
0xC54	EMACHOSRXBA	Ethernet MAC Current Host Receive Buffer Address
0xFC0	EMACPP	Ethernet MAC Peripheral Property Register
0xFC4	EMACPC	Ethernet MAC Peripheral Configuration
0xFC8	EMACCC	Ethernet MAC Clock Configuration
0xFD0	EPHYRIS	Ethernet PHY Raw Interrupt Status
0xFD4	EPHYIM	Ethernet PHY Interrupt Mask

表 6-14. Ethernet MAC (EMAC) Registers (continued)

OFFSET	ACRONYM	REGISTER NAME
0xFD8	EPHYMISC	Ethernet PHY Masked Interrupt Status and Clear

表 6-15. Ethernet MII Management (EPHY) Registers (Accessed Through the EMACMIADDR Register)

ADDRESS	ACRONYM	REGISTER NAME
0x00	EPHYBMCR	Ethernet PHY Basic Mode Control - MR0
0x01	EPHYBMSR	Ethernet PHY Basic Mode Status - MR1
0x02	EPHYID1	Ethernet PHY Identifier Register 1 - MR2
0x03	EPHYID2	Ethernet PHY Identifier Register 2 - MR3
0x04	EPHYANA	Ethernet PHY Auto-Negotiation Advertisement - MR4
0x05	EPHYANLPA	Ethernet PHY Auto-Negotiation Link Partner Ability -MR5
0x06	EPHYANER	Ethernet PHY Auto-Negotiation Expansion - MR6
0x07	EPHYANNPTR	Ethernet PHY Auto-Negotiation Next Page TX - MR7
0x08	EPHYANLNPTR	Ethernet PHY Auto-Negotiation Link Partner Ability Next Page - MR8
0x09	EPHYCFG1	Ethernet PHY Configuration 1 - MR9
0x0A	EPHYCFG2	Ethernet PHY Configuration 2 - MR10
0x0B	EPHYCFG3	Ethernet PHY Configuration 3 - MR11
0x0D	EPHYREGCTL	Ethernet PHY Register Control - MR13
0x0E	EPHYADDAR	Ethernet PHY Address or Data - MR14
0x10	EPHYSTS	Ethernet PHY Status - MR16
0x11	EPHYSCR	Ethernet PHY Specific Control - MR17
0x12	EPHYMISR1	Ethernet PHY MII Interrupt Status 1 - MR18
0x13	EPHYMISR2	Ethernet PHY MII Interrupt Status 2 - MR19
0x14	EPHYFCSR	Ethernet PHY False Carrier Sense Counter - MR20
0x15	EPHYRXERCNT	Ethernet PHY Receive Error Count - MR21
0x16	EPHYBISTCR	Ethernet PHY BIST Control - MR22
0x18	EPHYLEDCR	Ethernet PHY LED Control - MR24
0x19	EPHYCTL	Ethernet PHY Control - MR25
0x1A	EPHY10BTSC	Ethernet PHY 10Base-T Status/Control - MR26
0x1B	EPHYBICSR1	Ethernet PHY BIST Control and Status 1 - MR27
0x1C	EPHYBICSR2	Ethernet PHY BIST Control and Status 2 - MR28
0x1E	EPHYCDR	Ethernet PHY Cable Diagnostic Control - MR30
0x1F	EPHYRCR	Ethernet PHY Reset Control - MR31
0x25	EPHYLEDCFG	Ethernet PHY LED Configuration - MR37

表 6-16. Flash Registers

OFFSET	ACRONYM	REGISTER NAME
0x0	FMA	Flash Memory Address
0x4	FMD	Flash Memory Data
0x8	FMC	Flash Memory Control
0xC	FCRIS	Flash Controller Raw Interrupt Status
0x10	FCIM	Flash Controller Interrupt Mask
0x14	FCMISC	Flash Controller Masked Interrupt Status and Clear
0x20	FMC2	Flash Memory Control 2
0x30	FWBVAL	Flash Write Buffer Valid
0x3C	FLPEKEY	Flash Program/Erase Key
0x100 to 0x17C	FWB0 to FWB31	Flash Write Buffer 0 to Flash Write Buffer 32
0xFC0	FLASHPP	Flash Peripheral Properties

表 6-16. Flash Registers (continued)

OFFSET	ACRONYM	REGISTER NAME
0xFC4	SSIZE	SRAM Size
0xFC8	FLASHCONF	Flash Configuration Register
0xFCC	ROMSWMAP	ROM Third-Party Software
0xFD0	FLASHDMASZ	Flash DMA Address Size
0xFD4	FLASHDMAST	Flash DMA Starting Address

表 6-17. GPIO Registers

OFFSET	ACRONYM	REGISTER NAME
0x0	GPIODATA	GPIO Data
0x400	GPIODIR	GPIO Direction
0x404	GPIOIS	GPIO Interrupt Sense
0x408	GPIOIBE	GPIO Interrupt Both Edges
0x40C	GPIOIEV	GPIO Interrupt Event
0x410	GPIOIM	GPIO Interrupt Mask
0x414	GPIORIS	GPIO Raw Interrupt Status
0x418	GPIOMIS	GPIO Masked Interrupt Status
0x41C	GPIOICR	GPIO Interrupt Clear
0x420	GPIOAFSEL	GPIO Alternate Function Select
0x500	GPIODR2R	GPIO 2-mA Drive Select
0x504	GPIODR4R	GPIO 4-mA Drive Select
0x508	GPIODR8R	GPIO 8-mA Drive Select
0x50C	GPIODR	GPIO Open Drain Select
0x510	GPIOPUR	GPIO Pullup Select
0x514	GPIOPDR	GPIO Pulldown Select
0x518	GPIOSLR	GPIO Slew Rate Control Select
0x51C	GPIODEN	GPIO Digital Enable
0x520	GPIOLOCK	GPIO Lock
0x524	GPIOCR	GPIO Commit
0x528	GPIOAMSEL	GPIO Analog Mode Select
0x52C	GPIOPCTL	GPIO Port Control
0x530	GPIOADCCTL	GPIO ADC Control
0x534	GPIODMACTL	GPIO DMA Control
0x538	GPIOSI	GPIO Select Interrupt
0x53C	GPIODR12R	GPIO 12-mA Drive Select
0x540	GPIOWAKEPEN	GPIO Wake Pin Enable
0x544	GPIOWAKELVL	GPIO Wake Level
0x548	GPIOWAKESTAT	GPIO Wake Status
0xFC0	GPIOPP	GPIO Peripheral Property
0xFC4	GPIOPC	GPIO Peripheral Configuration
0xFD0	GPIOPeriphID4	GPIO Peripheral Identification 4
0xFD4	GPIOPeriphID5	GPIO Peripheral Identification 5
0xFD8	GPIOPeriphID6	GPIO Peripheral Identification 6
0xFDC	GPIOPeriphID7	GPIO Peripheral Identification 7
0xFE0	GPIOPeriphID0	GPIO Peripheral Identification 0
0xFE4	GPIOPeriphID1	GPIO Peripheral Identification 1
0xFE8	GPIOPeriphID2	GPIO Peripheral Identification 2
0xFEC	GPIOPeriphID3	GPIO Peripheral Identification 3

表 6-17. GPIO Registers (continued)

OFFSET	ACRONYM	REGISTER NAME
0xFF0	GPIOPCellID0	GPIO PrimeCell Identification 0
0xFF4	GPIOPCellID1	GPIO PrimeCell Identification 1
0xFF8	GPIOPCellID2	GPIO PrimeCell Identification 2
0xFFC	GPIOPCellID3	GPIO PrimeCell Identification 3

表 6-18. GPTM Registers

OFFSET	ACRONYM	REGISTER NAME
0x0	GPTMCFG	GPTM Configuration
0x4	GPTMTAMR	GPTM Timer A Mode
0x8	GPTMTBMR	GPTM Timer B Mode
0xC	GPTMCTL	GPTM Control
0x10	GPTMSYNC	GPTM Synchronize
0x18	GPTMIMR	GPTM Interrupt Mask
0x1C	GPTMRIS	GPTM Raw Interrupt Status
0x20	GPTMMIS	GPTM Masked Interrupt Status
0x24	GPTMICR	GPTM Interrupt Clear
0x28	GPTMTAILR	GPTM Timer A Interval Load
0x2C	GPTMTBILR	GPTM Timer B Interval Load
0x30	GPTMTAMATCHR	GPTM Timer A Match
0x34	GPTMTBMATCHR	GPTM Timer B Match
0x38	GPTMTAPR	GPTM Timer A Prescale
0x3C	GPTMTBPR	GPTM Timer B Prescale
0x40	GPTMTAPMR	GPTM TimerA Prescale Match
0x44	GPTMTBPMR	GPTM TimerB Prescale Match
0x48	GPTMTAR	GPTM Timer A
0x4C	GPTMTBR	GPTM Timer B
0x50	GPTMTAV	GPTM Timer A Value
0x54	GPTMTBV	GPTM Timer B Value
0x58	GPTMRTCPD	GPTM RTC Predivide
0x5C	GPTMTAPS	GPTM Timer A Prescale Snapshot
0x60	GPTMTBPS	GPTM Timer B Prescale Snapshot
0x6C	GPTMDMAEV	GPTM DMA Event
0x70	GPTMADCEV	GPTM ADC Event
0xFC0	GPTMPP	GPTM Peripheral Properties
0xFC8	GPTMCC	GPTM Clock Configuration

表 6-19. HIB Registers

OFFSET	ACRONYM	REGISTER NAME
0x0	HIBRTCC	Hibernation RTC Counter
0x4	HIBRTCM0	Hibernation RTC Match 0
0xC	HIBRTCLD	Hibernation RTC Load
0x10	HIBCTL	Hibernation Control
0x14	HIBIM	Hibernation Interrupt Mask
0x18	HIBRIS	Hibernation Raw Interrupt Status
0x1C	HIBMIS	Hibernation Masked Interrupt Status
0x20	HIBIC	Hibernation Interrupt Clear
0x24	HIBRTCT	Hibernation RTC Trim

表 6-19. HIB Registers (continued)

OFFSET	ACRONYM	REGISTER NAME
0x28	HIBRTCSS	Hibernation RTC Sub Seconds
0x2C	HIBIO	Hibernation IO Configuration
0x30 to 0x6F	HIBDATA	Hibernation Data
0x300	HIBCALCTL	Hibernation Calendar Control
0x310	HIBCAL0	Hibernation Calendar 0
0x314	HIBCAL1	Hibernation Calendar 1
0x320	HIBCALLD0	Hibernation Calendar Load 0
0x324	HIBCALLD1	Hibernation Calendar Load 1
0x330	HIBCALM0	Hibernation Calendar Match 0
0x334	HIBCALM1	Hibernation Calendar Match 1
0x360	HIBLOCK	Hibernation Lock
0x400	HIBTPCTL	HIB Tamper Control
0x404	HIBTPSTAT	HIB Tamper Status
0x410	HIBTPIO	HIB Tamper I/O Control
0x4E0	HIBTPLOG0	HIB Tamper Log 0
0x4E4	HIBTPLOG1	HIB Tamper Log 1
0x4E8	HIBTPLOG2	HIB Tamper Log 2
0x4EC	HIBTPLOG3	HIB Tamper Log 3
0x4F0	HIBTPLOG4	HIB Tamper Log 4
0x4F4	HIBTPLOG5	HIB Tamper Log 5
0x4F8	HIBTPLOG6	HIB Tamper Log 6
0x4FC	HIBTPLOG7	HIB Tamper Log 7
0xFC0	HIBPP	Hibernation Peripheral Properties
0xFC8	HIBCC	Hibernation Clock Control

表 6-20. I2C Registers

OFFSET	ACRONYM	REGISTER NAME
0x0	I2CMSA	I2C Master Slave Address
0x4	I2CMCS	I2C Master Control/Status
0x8	I2CMRDR	I2C Master Data
0xC	I2CMTPR	I2C Master Timer Period
0x10	I2CMIMR	I2C Master Interrupt Mask
0x14	I2CMRIS	I2C Master Raw Interrupt Status
0x18	I2CMMIS	I2C Master Masked Interrupt Status
0x1C	I2CMICR	I2C Master Interrupt Clear
0x20	I2CMCR	I2C Master Configuration
0x24	I2CMCLKOCNT	I2C Master Clock Low Time-out Count
0x2C	I2CMBMON	I2C Master Bus Monitor
0x30	I2CMBLEN	I2C Master Burst Length
0x34	I2CMBCNT	I2C Master Burst Count
0x800	I2CSOAR	I2C Slave Own Address
0x804	I2CSCSR	I2C Slave Control/Status
0x808	I2CSDR	I2C Slave Data
0x80C	I2CSIMR	I2C Slave Interrupt Mask
0x810	I2CSRIS	I2C Slave Raw Interrupt Status
0x814	I2CSMIS	I2C Slave Masked Interrupt Status
0x818	I2CSICR	I2C Slave Interrupt Clear

表 6-20. I2C Registers (continued)

OFFSET	ACRONYM	REGISTER NAME
0x81C	I2CSOAR2	I2C Slave Own Address 2
0x820	I2CSACKCTL	I2C Slave ACK Control
0xF00	I2CFIFODATA	I2C FIFO Data
0xF04	I2CFIFOCTL	I2C FIFO Control
0xF08	I2CFIFOSTATUS	I2C FIFO Status
0xFC0	I2CPP	I2C Peripheral Properties
0xFC4	I2CPC	I2C Peripheral Configuration

表 6-21. μ DMA Registers

OFFSET	ACRONYM	REGISTER NAME
0x0	DMASTAT	DMA Status
0x4	DMACFG	DMA Configuration
0x8	DMACTLBASE	DMA Channel Control Base Pointer
0xC	DMAALTBASE	DMA Alternate Channel Control Base Pointer
0x10	DMAWAITSTAT	DMA Channel Wait-on-Request Status
0x14	DMASWREQ	DMA Channel Software Request
0x18	DMAUSEBURSTSET	DMA Channel Useburst Set
0x1C	DMAUSEBURSTCLR	DMA Channel Useburst Clear
0x20	DMAREQMASKSET	DMA Channel Request Mask Set
0x24	DMAREQMASKCLR	DMA Channel Request Mask Clear
0x28	DMAENASET	DMA Channel Enable Set
0x2C	DMAENACLAR	DMA Channel Enable Clear
0x30	DMAALTSET	DMA Channel Primary Alternate Set
0x34	DMAALTCLR	DMA Channel Primary Alternate Clear
0x38	DMAPRIOSET	DMA Channel Priority Set
0x3C	DMAPRIOCLR	DMA Channel Priority Clear
0x4C	DMAERRCLR	DMA Bus Error Clear
0x510	DMACHMAP0	DMA Channel Map Select 0
0x514	DMACHMAP1	DMA Channel Map Select 1
0x518	DMACHMAP2	DMA Channel Map Select 2
0x51C	DMACHMAP3	DMA Channel Map Select 3
0xFD0	DMAPeriphID4	DMA Peripheral Identification 4
0xFE0	DMAPeriphID0	DMA Peripheral Identification 0
0xFE4	DMAPeriphID1	DMA Peripheral Identification 1
0xFE8	DMAPeriphID2	DMA Peripheral Identification 2
0xFEC	DMAPeriphID3	DMA Peripheral Identification 3
0xFF0	DMAPrimeCellID0	DMA PrimeCell Identification 0
0xFF4	DMAPrimeCellID1	DMA PrimeCell Identification 1
0xFF8	DMAPrimeCellID2	DMA PrimeCell Identification 2
0xFFC	DMAPrimeCellID3	DMA PrimeCell Identification 3

表 6-22. μ DMA Channel Control Structure Registers

OFFSET	ACRONYM	REGISTER NAME
0x0	DMASRCENDP	DMA Channel Source Address End Pointer
0x4	DMADSTENDP	DMA Channel Destination Address End Pointer
0x8	DMACHCTL	DMA Channel Control Word

表 6-23. PWM Registers

OFFSET	ACRONYM	REGISTER NAME
0x0	PWMCTL	PWM Master Control
0x4	PWMSYNC	PWM Time Base Sync
0x8	PWMENABLE	PWM Output Enable
0xC	PWMINVERT	PWM Output Inversion
0x10	PWMFAULT	PWM Output Fault
0x14	PWMINTEN	PWM Interrupt Enable
0x18	PWMRIS	PWM Raw Interrupt Status
0x1C	PWMISC	PWM Interrupt Status and Clear
0x20	PWMSTATUS	PWM Status
0x24	PWMFAULTVAL	PWM Fault Condition Value
0x28	PWMENUPD	PWM Enable Update
0x40	PWM0CTL	PWM0 Control
0x44	PWM0INTEN	PWM0 Interrupt and Trigger Enable
0x48	PWM0RIS	PWM0 Raw Interrupt Status
0x4C	PWM0ISC	PWM0 Interrupt Status and Clear
0x50	PWM0LOAD	PWM0 Load
0x54	PWM0COUNT	PWM0 Counter
0x58	PWM0CMPA	PWM0 Compare A
0x5C	PWM0CMPB	PWM0 Compare B
0x60	PWM0GENA	PWM0 Generator A Control
0x64	PWM0GENB	PWM0 Generator B Control
0x68	PWM0DBCTL	PWM0 Dead-Band Control
0x6C	PWM0DBRISE	PWM0 Dead-Band Rising-Edge Delay
0x70	PWM0DBFALL	PWM0 Dead-Band Falling-Edge-Delay
0x74	PWM0FLTSRC0	PWM0 Fault Source 0
0x78	PWM0FLTSRC1	PWM0 Fault Source 1
0x7C	PWM0MINFLTPER	PWM0 Minimum Fault Period
0x080	PWM1CTL	PWM1 Control
0x084	PWM1INTEN	PWM1 Interrupt and Trigger Enable
0x088	PWM1RIS	PWM1 Raw Interrupt Status
0x08C	PWM1ISC	PWM1 Interrupt Status and Clear
0x090	PWM1LOAD	PWM1 Load
0x094	PWM1COUNT	PWM1 Counter
0x098	PWM1CMPA	PWM1 Compare A
0x09C	PWM1CMPB	PWM1 Compare B
0x0A0	PWM1GENA	PWM1 Generator A Control
0x0A4	PWM1GENB	PWM1 Generator B Control
0x0A8	PWM1DBCTL	PWM1 Dead-Band Control
0x0AC	PWM1DBRISE	PWM1 Dead-Band Rising-Edge Delay
0x0B0	PWM1DBFALL	PWM1 Dead-Band Falling-Edge-Delay
0x0B4	PWM1FLTSRC0	PWM1 Fault Source 0
0x0B8	PWM1FLTSRC1	PWM1 Fault Source 1
0x0BC	PWM1MINFLTPER	PWM1 Minimum Fault Period
0x0C0	PWM2CTL	PWM2 Control
0x0C4	PWM2INTEN	PWM2 Interrupt and Trigger Enable
0x0C8	PWM2RIS	PWM2 Raw Interrupt Status
0x0CC	PWM2ISC	PWM2 Interrupt Status and Clear

表 6-23. PWM Registers (continued)

OFFSET	ACRONYM	REGISTER NAME
0x0D0	PWM2LOAD	PWM2 Load
0x0D4	PWM2COUNT	PWM2 Counter
0x0D8	PWM2CMPA	PWM2 Compare A
0x0DC	PWM2CMPB	PWM2 Compare B
0x0E0	PWM2GENA	PWM2 Generator A Control
0x0E4	PWM2GENB	PWM2 Generator B Control
0x0E8	PWM2DBCTL	PWM2 Dead-Band Control
0x0EC	PWM2DBRISE	PWM2 Dead-Band Rising-Edge Delay
0x0F0	PWM2DBFALL	PWM2 Dead-Band Falling-Edge-Delay
0x0F4	PWM2FLTSRC0	PWM2 Fault Source 0
0x0F8	PWM2FLTSRC1	PWM2 Fault Source 1
0x0FC	PWM2MINFLTPER	PWM2 Minimum Fault Period
0x100	PWM3CTL	PWM3 Control
0x104	PWM3INTEN	PWM3 Interrupt and Trigger Enable
0x108	PWM3RIS	PWM3 Raw Interrupt Status
0x10C	PWM3ISC	PWM3 Interrupt Status and Clear
0x110	PWM3LOAD	PWM3 Load
0x114	PWM3COUNT	PWM3 Counter
0x118	PWM3CMPA	PWM3 Compare A
0x11C	PWM3CMPB	PWM3 Compare B
0x120	PWM3GENA	PWM3 Generator A Control
0x124	PWM3GENB	PWM3 Generator B Control
0x128	PWM3DBCTL	PWM3 Dead-Band Control
0x12C	PWM3DBRISE	PWM3 Dead-Band Rising-Edge Delay
0x130	PWM3DBFALL	PWM3 Dead-Band Falling-Edge-Delay
0x134	PWM3FLTSRC0	PWM3 Fault Source 0
0x138	PWM3FLTSRC1	PWM3 Fault Source 1
0x13C	PWM3MINFLTPER	PWM3 Minimum Fault Period
0x800	PWM0FLTSEN	PWM0 Fault Pin Logic Sense
0x804	PWM0FLTSTAT0	PWM0 Fault Status 0
0x808	PWM0FLTSTAT1	PWM0 Fault Status 1
0x880	PWM1FLTSEN	PWM1 Fault Pin Logic Sense
0x884	PWM1FLTSTAT0	PWM1 Fault Status 0
0x888	PWM1FLTSTAT1	PWM1 Fault Status 1
0x900	PWM2FLTSEN	PWM2 Fault Pin Logic Sense
0x904	PWM2FLTSTAT0	PWM2 Fault Status 0
0x908	PWM2FLTSTAT1	PWM2 Fault Status 1
0x980	PWM3FLTSEN	PWM3 Fault Pin Logic Sense
0x984	PWM3FLTSTAT0	PWM3 Fault Status 0
0x988	PWM3FLTSTAT1	PWM3 Fault Status 1
0xFC0	PWMPP	PWM Peripheral Properties
0xFC8	PWMCC	PWM Clock Configuration

表 6-24. QEI Registers

OFFSET	ACRONYM	REGISTER NAME
0x0	QEICTL	QEI Control
0x4	QEISTAT	QEI Status

表 6-24. QEI Registers (continued)

OFFSET	ACRONYM	REGISTER NAME
0x8	QEIPOS	QEI Position
0xC	QEIMAXPOS	QEI Maximum Position
0x10	QEILOAD	QEI Timer Load
0x14	QEITIME	QEI Timer
0x18	QEICOUNT	QEI Velocity Counter
0x1C	QEISPEED	QEI Velocity
0x20	QEIINTEN	QEI Interrupt Enable
0x24	QEIRIS	QEI Raw Interrupt Status
0x28	QEISC	QEI Interrupt Status and Clear

表 6-25. QSSI Registers

OFFSET	ACRONYM	REGISTER NAME
0x0	SSICR0	QSSI Control 0
0x4	SSICR1	QSSI Control 1
0x8	SSIDR	QSSI Data
0xC	SSISR	QSSI Status
0x10	SSICPSR	QSSI Clock Prescale
0x14	SSIIM	QSSI Interrupt Mask
0x18	SSIRIS	QSSI Raw Interrupt Status
0x1C	SSIMIS	QSSI Masked Interrupt Status
0x20	SSIICR	QSSI Interrupt Clear
0x24	SSIDMACTL	QSSI DMA Control
0xFC0	SSIPP	QSSI Peripheral Properties
0xFC8	SSICC	QSSI Clock Configuration
0xFD0	SSIPeriphID4	QSSI Peripheral Identification 4
0xFD4	SSIPeriphID5	QSSI Peripheral Identification 5
0xFD8	SSIPeriphID6	QSSI Peripheral Identification 6
0xFDC	SSIPeriphID7	QSSI Peripheral Identification 7
0xFE0	SSIPeriphID0	QSSI Peripheral Identification 0
0xFE4	SSIPeriphID1	QSSI Peripheral Identification 1
0xFE8	SSIPeriphID2	QSSI Peripheral Identification 2
0xFEC	SSIPeriphID3	QSSI Peripheral Identification 3
0xFF0	SSIPCellID0	QSSI PrimeCell Identification 0
0xFF4	SSIPCellID1	QSSI PrimeCell Identification 1
0xFF8	SSIPCellID2	QSSI PrimeCell Identification 2
0xFFC	SSIPCellID3	QSSI PrimeCell Identification 3

表 6-26. SHA/MD5 Registers

OFFSET	ACRONYM	REGISTER NAME
0x000	SHA_ODIGEST_A	SHA Outer Digest A
0x004	SHA_ODIGEST_B	SHA Outer Digest B
0x008	SHA_ODIGEST_C	SHA Outer Digest C
0x00C	SHA_ODIGEST_D	SHA Outer Digest D
0x010	SHA_ODIGEST_E	SHA Outer Digest E
0x014	SHA_ODIGEST_F	SHA Outer Digest F
0x018	SHA_ODIGEST_G	SHA Outer Digest G
0x01C	SHA_ODIGEST_H	SHA Outer Digest H

表 6-26. SHA/MD5 Registers (continued)

OFFSET	ACRONYM	REGISTER NAME
0x020	SHA_IDIGEST_A	SHA Inner Digest A
0x024	SHA_IDIGEST_B	SHA Inner Digest B
0x028	SHA_IDIGEST_C	SHA Inner Digest C
0x02C	SHA_IDIGEST_D	SHA Inner Digest D
0x030	SHA_IDIGEST_E	SHA Inner Digest E
0x034	SHA_IDIGEST_F	SHA Inner Digest F
0x038	SHA_IDIGEST_G	SHA Inner Digest G
0x03C	SHA_IDIGEST_H	SHA Inner Digest H
0x40	SHA_DIGEST_COUNT	SHA Digest Count
0x44	SHA_MODE	SHA Mode
0x48	SHA_LENGTH	SHA Length
0x080	SHA_DATA_0_IN	SHA Data 0 Input
0x084	SHA_DATA_1_IN	SHA Data 1 Input
0x088	SHA_DATA_2_IN	SHA Data 2 Input
0x08C	SHA_DATA_3_IN	SHA Data 3 Input
0x090	SHA_DATA_4_IN	SHA Data 4 Input
0x094	SHA_DATA_5_IN	SHA Data 5 Input
0x098	SHA_DATA_6_IN	SHA Data 6 Input
0x09C	SHA_DATA_7_IN	SHA Data 7 Input
0x0A0	SHA_DATA_8_IN	SHA Data 8 Input
0x0A4	SHA_DATA_9_IN	SHA Data 9 Input
0x0A8	SHA_DATA_10_IN	SHA Data 10 Input
0x0AC	SHA_DATA_11_IN	SHA Data 11 Input
0x0B0	SHA_DATA_12_IN	SHA Data 12 Input
0x0B4	SHA_DATA_13_IN	SHA Data 13 Input
0x0B8	SHA_DATA_14_IN	SHA Data 14 Input
0x0BC	SHA_DATA_15_IN	SHA Data 15 Input
0x100	SHA_REVISION	SHA Revision
0x110	SHA_SYSCONFIG	SHA System Configuration
0x114	SHA_SYSSTATUS	SHA System Status
0x118	SHA_IRQSTATUS	SHA Interrupt Status
0x11C	SHA_IRQENABLE	SHA Interrupt Enable

表 6-27. SHA/MD5 μ DMA Registers

OFFSET	ACRONYM	REGISTER NAME
0x10	SHA_DMAIM	SHA DMA Interrupt Mask
0x14	SHA_DMARIS	SHA DMA Raw Interrupt Status
0x18	SHA_DMAMIS	SHA DMA Masked Interrupt Status
0x1C	SHA_DMAIC	SHA DMA Interrupt Clear

表 6-28. System Control Memory Registers

OFFSET	ACRONYM	REGISTER NAME
0xD4	RVP	Reset Vector Pointer
0x1D0	BOOTCFG	Boot Configuration
0x1E0 to 0x1EC	USER_REG_0 to USER_REG_3	User Register 0 to User Register 3
0x200 to 0x23C	FMPRE_0 to FMPRE_15	Flash Memory Protection Read Enable 0 to Flash Memory Protection Read Enable 15

表 6-28. System Control Memory Registers (continued)

OFFSET	ACRONYM	REGISTER NAME
0x400 to 0x43C	FMPPE_0 to FMPPE_15	Flash Memory Protection Program Enable 0 to Flash Memory Protection Program Enable 15

表 6-29. System Exception Registers

OFFSET	ACRONYM	REGISTER NAME
0x0	SYSEXCRIS	System Exception Raw Interrupt Status
0x4	SYSEXCIM	System Exception Interrupt Mask
0x8	SYSEXCMI5	System Exception Masked Interrupt Status
0xC	SYSEXCIC	System Exception Interrupt Clear

表 6-30. UART Registers

OFFSET	ACRONYM	REGISTER NAME
0x0	UARTDR	UART Data
0x4	UARTRSR/UARTECR	UART Receive Status/Error Clear
0x18	UARTFR	UART Flag
0x20	UARTILPR	UART IrDA Low-Power Register
0x24	UARTIBRD	UART Integer Baud-Rate Divisor
0x28	UARTFBRD	UART Fractional Baud-Rate Divisor
0x2C	UARTLCRH	UART Line Control
0x30	UARTCTL	UART Control
0x34	UARTIFLS	UART Interrupt FIFO Level Select
0x38	UARTIM	UART Interrupt Mask
0x3C	UARTRIS	UART Raw Interrupt Status
0x40	UARTMIS	UART Masked Interrupt Status
0x44	UARTICR	UART Interrupt Clear
0x48	UARTDMACTL	UART DMA Control
0xA4	UART9BITADDR	UART 9-Bit Self Address
0xA8	UART9BITAMASK	UART 9-Bit Self Address Mask
0xFC0	UARTPP	UART Peripheral Properties
0xFC8	UARTCC	UART Clock Configuration
0xFD0	UARTPeriphID4	UART Peripheral Identification 4
0xFD4	UARTPeriphID5	UART Peripheral Identification 5
0xFD8	UARTPeriphID6	UART Peripheral Identification 6
0xFDC	UARTPeriphID7	UART Peripheral Identification 7
0xFE0	UARTPeriphID0	UART Peripheral Identification 0
0xFE4	UARTPeriphID1	UART Peripheral Identification 1
0xFE8	UARTPeriphID2	UART Peripheral Identification 2
0xFEC	UARTPeriphID3	UART Peripheral Identification 3
0xFF0	UARTPCelIID0	UART PrimeCell Identification 0
0xFF4	UARTPCelIID1	UART PrimeCell Identification 1
0xFF8	UARTPCelIID2	UART PrimeCell Identification 2
0xFFC	UARTPCelIID3	UART PrimeCell Identification 3

表 6-31. USB Registers

OFFSET	ACRONYM	REGISTER NAME
0x0	USBFADDR	USB Device Functional Address
0x1	USBPOWER	USB Power

表 6-31. USB Registers (continued)

OFFSET	ACRONYM	REGISTER NAME
0x2	USBTXIS	USB Transmit Interrupt Status
0x4	USBRXIS	USB Receive Interrupt Status
0x6	USBTXIE	USB Transmit Interrupt Enable
0x8	USBRXIE	USB Receive Interrupt Enable
0xA	USBIS	USB General Interrupt Status
0xB	USBIE	USB Interrupt Enable
0xC	USBFRAME	USB Frame Value
0xE	USBEPIDX	USB Endpoint Index
0xF	USBTEST	USB Test Mode
0x20	USBFIFO0	USB FIFO Endpoint 0
0x24	USBFIFO1	USB FIFO Endpoint 1
0x28	USBFIFO2	USB FIFO Endpoint 2
0x2C	USBFIFO3	USB FIFO Endpoint 3
0x30	USBFIFO4	USB FIFO Endpoint 4
0x34	USBFIFO5	USB FIFO Endpoint 5
0x38	USBFIFO6	USB FIFO Endpoint 6
0x3C	USBFIFO7	USB FIFO Endpoint 7
0x60	USBDEVCTL	USB Device Control
0x61	USBCCONF	USB Common Configuration
0x62	USBTXFIFOSZ	USB Transmit Dynamic FIFO Sizing
0x63	USBRXFIFOSZ	USB Receive Dynamic FIFO Sizing
0x64	USBTXFIFOADD	USB Transmit FIFO Start Address
0x66	USBRXFIFOADD	USB Receive FIFO Start Address
0x70	ULPIVBUSCTL	USB ULPI VBUS Control
0x74	ULPIREGDATA	USB ULPI Register Data
0x75	ULPIREGADDR	USB ULPI Register Address
0x76	ULPIREGCTL	USB ULPI Register Control
0x78	USBEPINFO	USB Endpoint Information
0x79	USBRAMINFO	USB RAM Information
0x7A	USBCONTIM	USB Connect Timing
0x7B	USBVPLEN	USB OTG VBUS Pulse Timing
0x7C	USBHSEOF	USB High-Speed Last Transaction to End of Frame Timing
0x7D	USBFSEOF	USB Full-Speed Last Transaction to End of Frame Timing
0x7E	USBLSEOF	USB Low-Speed Last Transaction to End of Frame Timing
0x80	USBTXFUNCADDR0	USB Transmit Functional Address Endpoint 0
0x82	USBTXHUBADDR0	USB Transmit Hub Address Endpoint 0
0x83	USBTXHUBPORT0	USB Transmit Hub Port Endpoint 0
0x88	USBTXFUNCADDR1	USB Transmit Functional Address Endpoint 1
0x8A	USBTXHUBADDR1	USB Transmit Hub Address Endpoint 1
0x8B	USBTXHUBPORT1	USB Transmit Hub Port Endpoint 1
0x8C	USBRXFUNCADDR1	USB Receive Functional Address Endpoint 1
0x8E	USBRXHUBADDR1	USB Receive Hub Address Endpoint 1
0x8F	USBRXHUBPORT1	USB Receive Hub Port Endpoint 1
0x90	USBTXFUNCADDR2	USB Transmit Functional Address Endpoint 2
0x92	USBTXHUBADDR2	USB Transmit Hub Address Endpoint 2
0x93	USBTXHUBPORT2	USB Transmit Hub Port Endpoint 2
0x94	USBRXFUNCADDR2	USB Receive Functional Address Endpoint 2

表 6-31. USB Registers (continued)

OFFSET	ACRONYM	REGISTER NAME
0x96	USBRXHUBADDR2	USB Receive Hub Address Endpoint 2
0x97	USBRXHUBPORT2	USB Receive Hub Port Endpoint 2
0x98	USBTXFUNCADDR3	USB Transmit Functional Address Endpoint 3
0x9A	USBTXHUBADDR3	USB Transmit Hub Address Endpoint 3
0x9B	USBTXHUBPORT3	USB Transmit Hub Port Endpoint 3
0x9C	USBRXFUNCADDR3	USB Receive Functional Address Endpoint 3
0x9E	USBRXHUBADDR3	USB Receive Hub Address Endpoint 3
0x9F	USBRXHUBPORT3	USB Receive Hub Port Endpoint 3
0xA0	USBTXFUNCADDR4	USB Transmit Functional Address Endpoint 4
0xA2	USBTXHUBADDR4	USB Transmit Hub Address Endpoint 4
0xA3	USBTXHUBPORT4	USB Transmit Hub Port Endpoint 4
0xA4	USBRXFUNCADDR4	USB Receive Functional Address Endpoint 4
0xA6	USBRXHUBADDR4	USB Receive Hub Address Endpoint 4
0xA7	USBRXHUBPORT4	USB Receive Hub Port Endpoint 4
0xA8	USBTXFUNCADDR5	USB Transmit Functional Address Endpoint 5
0xAA	USBTXHUBADDR5	USB Transmit Hub Address Endpoint 5
0xAB	USBTXHUBPORT5	USB Transmit Hub Port Endpoint 5
0xAC	USBRXFUNCADDR5	USB Receive Functional Address Endpoint 5
0xAE	USBRXHUBADDR5	USB Receive Hub Address Endpoint 5
0xAF	USBRXHUBPORT5	USB Receive Hub Port Endpoint 5
0xB0	USBTXFUNCADDR6	USB Transmit Functional Address Endpoint 6
0xB2	USBTXHUBADDR6	USB Transmit Hub Address Endpoint 6
0xB3	USBTXHUBPORT6	USB Transmit Hub Port Endpoint 6
0xB4	USBRXFUNCADDR6	USB Receive Functional Address Endpoint 6
0xB6	USBRXHUBADDR6	USB Receive Hub Address Endpoint 6
0xB7	USBRXHUBPORT6	USB Receive Hub Port Endpoint 6
0xB8	USBTXFUNCADDR7	USB Transmit Functional Address Endpoint 7
0xBA	USBTXHUBADDR7	USB Transmit Hub Address Endpoint 7
0xBB	USBTXHUBPORT7	USB Transmit Hub Port Endpoint 7
0xBC	USBRXFUNCADDR7	USB Receive Functional Address Endpoint 7
0xBE	USBRXHUBADDR7	USB Receive Hub Address Endpoint 7
0xBF	USBRXHUBPORT7	USB Receive Hub Port Endpoint 7
0x102	USBCSRL0	USB Control and Status Endpoint 0 Low
0x103	USBCSRH0	USB Control and Status Endpoint 0 High
0x108	USBCOUNT0	USB Receive Byte Count Endpoint 0
0x10A	USBTYP0	USB Type Endpoint 0
0x10B	USBNAKLMT	USB NAK Limit
0x110	USBTXMAXP1	USB Maximum Transmit Data Endpoint 1
0x112	USBTXCSSL1	USB Transmit Control and Status Endpoint 1 Low
0x113	USBTXCSRH1	USB Transmit Control and Status Endpoint 1 High
0x114	USBRXMAXP1	USB Maximum Receive Data Endpoint 1
0x116	USBRXCSSL1	USB Receive Control and Status Endpoint 1 Low
0x117	USBRXCSRH1	USB Receive Control and Status Endpoint 1 High
0x118	USBRXCOUNT1	USB Receive Byte Count Endpoint 1
0x11A	USBTXTYPE1	USB Host Transmit Configure Type Endpoint 1
0x11B	USBTXINTERVAL1	USB Host Transmit Interval Endpoint 1
0x11C	USBRXTYPE1	USB Host Configure Receive Type Endpoint 1

表 6-31. USB Registers (continued)

OFFSET	ACRONYM	REGISTER NAME
0x11D	USBRXINTERVAL1	USB Host Receive Polling Interval Endpoint 1
0x120	USBTXMAXP2	USB Maximum Transmit Data Endpoint 2
0x122	USBTXCSRL2	USB Transmit Control and Status Endpoint 2 Low
0x123	USBTXCSRH2	USB Transmit Control and Status Endpoint 2 High
0x124	USBRXMAXP2	USB Maximum Receive Data Endpoint 2
0x126	USBRXCSRL2	USB Receive Control and Status Endpoint 2 Low
0x127	USBRXCSRH2	USB Receive Control and Status Endpoint 2 High
0x128	USBRXCOUNT2	USB Receive Byte Count Endpoint 2
0x12A	USBTXTYPE2	USB Host Transmit Configure Type Endpoint 2
0x12B	USBTXINTERVAL2	USB Host Transmit Interval Endpoint 2
0x12C	USBRXTYPE2	USB Host Configure Receive Type Endpoint 2
0x12D	USBRXINTERVAL2	USB Host Receive Polling Interval Endpoint 2
0x130	USBTXMAXP3	USB Maximum Transmit Data Endpoint 3
0x132	USBTXCSRL3	USB Transmit Control and Status Endpoint 3 Low
0x133	USBTXCSRH3	USB Transmit Control and Status Endpoint 3 High
0x134	USBRXMAXP3	USB Maximum Receive Data Endpoint 3
0x136	USBRXCSRL3	USB Receive Control and Status Endpoint 3 Low
0x137	USBRXCSRH3	USB Receive Control and Status Endpoint 3 High
0x138	USBRXCOUNT3	USB Receive Byte Count Endpoint 3
0x13A	USBTXTYPE3	USB Host Transmit Configure Type Endpoint 3
0x13B	USBTXINTERVAL3	USB Host Transmit Interval Endpoint 3
0x13C	USBRXTYPE3	USB Host Configure Receive Type Endpoint 3
0x13D	USBRXINTERVAL3	USB Host Receive Polling Interval Endpoint 3
0x140	USBTXMAXP4	USB Maximum Transmit Data Endpoint 4
0x142	USBTXCSRL4	USB Transmit Control and Status Endpoint 4 Low
0x143	USBTXCSRH4	USB Transmit Control and Status Endpoint 4 High
0x144	USBRXMAXP4	USB Maximum Receive Data Endpoint 4
0x146	USBRXCSRL4	USB Receive Control and Status Endpoint 4 Low
0x147	USBRXCSRH4	USB Receive Control and Status Endpoint 4 High
0x148	USBRXCOUNT4	USB Receive Byte Count Endpoint 4
0x14A	USBTXTYPE4	USB Host Transmit Configure Type Endpoint 4
0x14B	USBTXINTERVAL4	USB Host Transmit Interval Endpoint 4
0x14C	USBRXTYPE4	USB Host Configure Receive Type Endpoint 4
0x14D	USBRXINTERVAL4	USB Host Receive Polling Interval Endpoint 4
0x150	USBTXMAXP5	USB Maximum Transmit Data Endpoint 5
0x152	USBTXCSRL5	USB Transmit Control and Status Endpoint 5 Low
0x153	USBTXCSRH5	USB Transmit Control and Status Endpoint 5 High
0x154	USBRXMAXP5	USB Maximum Receive Data Endpoint 5
0x156	USBRXCSRL5	USB Receive Control and Status Endpoint 5 Low
0x157	USBRXCSRH5	USB Receive Control and Status Endpoint 5 High
0x158	USBRXCOUNT5	USB Receive Byte Count Endpoint 5
0x15A	USBTXTYPE5	USB Host Transmit Configure Type Endpoint 5
0x15B	USBTXINTERVAL5	USB Host Transmit Interval Endpoint 5
0x15C	USBRXTYPE5	USB Host Configure Receive Type Endpoint 5
0x15D	USBRXINTERVAL5	USB Host Receive Polling Interval Endpoint 5
0x160	USBTXMAXP6	USB Maximum Transmit Data Endpoint 6
0x162	USBTXCSRL6	USB Transmit Control and Status Endpoint 6 Low

表 6-31. USB Registers (continued)

OFFSET	ACRONYM	REGISTER NAME
0x163	USBTXCSRH6	USB Transmit Control and Status Endpoint 6 High
0x164	USBRXMAXP6	USB Maximum Receive Data Endpoint 6
0x166	USBRXCSSL6	USB Receive Control and Status Endpoint 6 Low
0x167	USBRXCSRH6	USB Receive Control and Status Endpoint 6 High
0x168	USBRXCOUNT6	USB Receive Byte Count Endpoint 6
0x16A	USBTXTYPE6	USB Host Transmit Configure Type Endpoint 6
0x16B	USBTXINTERVAL6	USB Host Transmit Interval Endpoint 6
0x16C	USBRXTYPE6	USB Host Configure Receive Type Endpoint 6
0x16D	USBRXINTERVAL6	USB Host Receive Polling Interval Endpoint 6
0x170	USBTXMAXP7	USB Maximum Transmit Data Endpoint 7
0x172	USBTXCSSL7	USB Transmit Control and Status Endpoint 7 Low
0x173	USBTXCSRH7	USB Transmit Control and Status Endpoint 7 High
0x174	USBRXMAXP7	USB Maximum Receive Data Endpoint 7
0x176	USBRXCSSL7	USB Receive Control and Status Endpoint 7 Low
0x177	USBRXCSRH7	USB Receive Control and Status Endpoint 7 High
0x178	USBRXCOUNT7	USB Receive Byte Count Endpoint 7
0x17A	USBTXTYPE7	USB Host Transmit Configure Type Endpoint 7
0x17B	USBTXINTERVAL7	USB Host Transmit Interval Endpoint 7
0x17C	USBRXTYPE7	USB Host Configure Receive Type Endpoint 7
0x17D	USBRXINTERVAL7	USB Host Receive Polling Interval Endpoint 7
0x200	USBDMAINTR	USB DMA Interrupt
0x204	USBDMACTL0	USB DMA Control 0
0x208	USBDMAADDR0	USB DMA Address 0
0x20C	USBDMACOUNT0	USB DMA Count 0
0x214	USBDMACTL1	USB DMA Control 1
0x218	USBDMAADDR1	USB DMA Address 1
0x21C	USBDMACOUNT1	USB DMA Count 1
0x224	USBDMACTL2	USB DMA Control 2
0x228	USBDMAADDR2	USB DMA Address 2
0x22C	USBDMACOUNT2	USB DMA Count 2
0x234	USBDMACTL3	USB DMA Control 3
0x238	USBDMAADDR3	USB DMA Address 3
0x23C	USBDMACOUNT3	USB DMA Count 3
0x244	USBDMACTL4	USB DMA Control 4
0x248	USBDMAADDR4	USB DMA Address 4
0x24C	USBDMACOUNT4	USB DMA Count 4
0x254	USBDMACTL5	USB DMA Control 5
0x258	USBDMAADDR5	USB DMA Address 5
0x25C	USBDMACOUNT5	USB DMA Count 5
0x264	USBDMACTL6	USB DMA Control 6
0x268	USBDMAADDR6	USB DMA Address 6
0x26C	USBDMACOUNT6	USB DMA Count 6
0x274	USBDMACTL7	USB DMA Control 7
0x278	USBDMAADDR7	USB DMA Address 7
0x27C	USBDMACOUNT7	USB DMA Count 7
0x304	USBRQPKTCOUNT1	USB Request Packet Count in Block Transfer Endpoint 1
0x308	USBRQPKTCOUNT2	USB Request Packet Count in Block Transfer Endpoint 2

表 6-31. USB Registers (continued)

OFFSET	ACRONYM	REGISTER NAME
0x30C	USBRQPKTCOUNT3	USB Request Packet Count in Block Transfer Endpoint 3
0x310	USBRQPKTCOUNT4	USB Request Packet Count in Block Transfer Endpoint 4
0x314	USBRQPKTCOUNT5	USB Request Packet Count in Block Transfer Endpoint 5
0x318	USBRQPKTCOUNT6	USB Request Packet Count in Block Transfer Endpoint 6
0x31C	USBRQPKTCOUNT7	USB Request Packet Count in Block Transfer Endpoint 7
0x340	USBRXDPKTBUFFDIS	USB Receive Double Packet Buffer Disable
0x342	USBTXDPKTBUFFDIS	USB Transmit Double Packet Buffer Disable
0x344	USBCTO	USB Chirp Time-out
0x346	USBHHSRTN	USB High Speed to UTM Operating Delay
0x348	USBHSBT	USB High Speed Time-out Adder
0x360	USBLPMATTR	USB LPM Attributes
0x362	USBLPMCNTL	USB LPM Control
0x363	USBLPMIM	USB LPM Interrupt Mask
0x364	USBLPMRIS	USB LPM Raw Interrupt Status
0x365	USBLPMFADDR	USB LPM Function Address
0x400	USBEPCC	USB External Power Control
0x404	USBEPCCRIS	USB External Power Control Raw Interrupt Status
0x408	USBEPCCIM	USB External Power Control Interrupt Mask
0x40C	USBEPCCISC	USB External Power Control Interrupt Status and Clear
0x410	USBDRRIS	USB Device RESUME Raw Interrupt Status
0x414	USBDRIM	USB Device RESUME Interrupt Mask
0x418	USBDRISC	USB Device RESUME Interrupt Status and Clear
0x41C	USBGPCS	USB General-Purpose Control and Status
0x430	USBVDC	USB VBUS Droop Control
0x434	USBVDCRIS	USB VBUS Droop Control Raw Interrupt Status
0x438	USBVDCIM	USB VBUS Droop Control Interrupt Mask
0x43C	USBVDCISC	USB VBUS Droop Control Interrupt Status and Clear
0xFC0	USBPP	USB Peripheral Properties
0xFC4	USBPC	USB Peripheral Configuration
0xFC8	USBCC	USB Clock Configuration

表 6-32. WDT Registers

OFFSET	ACRONYM	REGISTER NAME
0x0	WDTLOAD	Watchdog Load
0x4	WDTVALUE	Watchdog Value
0x8	WDTCTL	Watchdog Control
0xC	WDTICR	Watchdog Interrupt Clear
0x10	WDTISR	Watchdog Raw Interrupt Status
0x14	WDTMIS	Watchdog Masked Interrupt Status
0x418	WDTTEST	Watchdog Test
0xC00	WDTLOCK	Watchdog Lock
0xFD0	WDTPeriphID4	Watchdog Peripheral Identification 4
0xFD4	WDTPeriphID5	Watchdog Peripheral Identification 5
0xFD8	WDTPeriphID6	Watchdog Peripheral Identification 6
0xFDC	WDTPeriphID7	Watchdog Peripheral Identification 7
0xFE0	WDTPeriphID0	Watchdog Peripheral Identification 0
0xFE4	WDTPeriphID1	Watchdog Peripheral Identification 1

表 6-32. WDT Registers (continued)

OFFSET	ACRONYM	REGISTER NAME
0xFE8	WDTPeriphID2	Watchdog Peripheral Identification 2
0xFEC	WDTPeriphID3	Watchdog Peripheral Identification 3
0xFF0	WDTPCellID0	Watchdog PrimeCell Identification 0
0xFF4	WDTPCellID1	Watchdog PrimeCell Identification 1
0xFF8	WDTPCellID2	Watchdog PrimeCell Identification 2
0xFFC	WDTPCellID3	Watchdog PrimeCell Identification 3

6.6 Identification

Device Identification

Read-only registers in the system control module provide information about the MCU, such as version, part number, pin count, operating temperature range, and available peripherals on the device. The Device Identification 0 (DID0) and Device Identification 1 (DID1) registers provide details about the version, package, and temperature range of the device. The peripheral present registers starting at system control offset 0x300, such as the Watchdog Timer Peripheral Present (PPWD) register, provide information on how many of each type of module are included on the device. Finally, information about the capabilities of the on-chip peripherals are provided at offset 0xFC0 in the register space of each peripheral in the peripheral properties registers, such as the GPTM Peripheral Properties (GPTMPP). In addition, four unique identifier registers, Unique Identifier n (UNIQUEIDn), provide a 128-bit unique identifier that cannot be modified for each device.

JTAG Identification

图 6-3 shows the format for the 32-bit IDCODE Data Register defined by the IEEE Standard 1149.1. The major uses of the JTAG port are for manufacturer testing of component assembly and program development and debug. To facilitate the use of auto-configuration debug tools, the IDCODE instruction outputs a value of 0x4BA0.0477. This value lets the debuggers automatically configure themselves to work correctly with the Cortex-M4F during debug.



图 6-3. IDCODE Register Format

ROM Version

The internal ROM is at address 0x0100.0000 of the device memory map.

6.7 Boot Modes

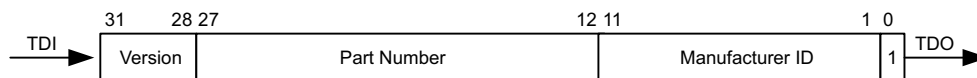
After POR and device initialization occurs, the hardware loads the stack pointer from either flash or ROM, based on the presence of an application in flash and the state of the EN bit in the BOOTCFG register.

If the flash address 0x0000.0004 contains an erased word (value 0xFFFF.FFFF) or the EN bit of the BOOTCFG register is clear, the stack pointer and reset vector pointer are loaded from ROM at address 0x0100.0000 and 0x0100.0004, respectively. The bootloader executes and configures the available boot slave interfaces and waits for a programmer, host PC, or boot server to load its software. The bootloader uses a simple packet interface to provide synchronous communication with the device for I²C, SSI, and UART. The speed of the bootloader is determined by the frequency of the internal oscillator (PIOSC) or external crystal (if connected).

The ROM invokes the USB and Ethernet bootloader only when an external crystal is detected. Also, the Ethernet bootloader works only when a 25-MHz crystal is detected.

The following serial interfaces can be used:

- UART0
- SSI0
- I2C0
- USB
- Ethernet MAC and Integrated PHY

If the check of the flash at address 0x0000.0004 contains a valid reset vector value and the EN bit in the BOOTCFG register is set, the stack pointer and reset vector values are fetched from the beginning of flash. This application stack pointer and reset vector are loaded and the processor executes the application directly. Otherwise, the stack pointer and reset vector values are fetched from the beginning of ROM.

7 Applications, Implementation, and Layout

注

Information in the following Applications section is not part of the TI component specification, and TI does not warrant its accuracy or completeness. TI's customers are responsible for determining suitability of components for their purposes. Customers should validate and test their design implementation to confirm system functionality.

7.1 System Design Guidelines

The SimpleLink MSP432E4 microcontrollers are highly-integrated system-on-chip (SoC) devices with extensive interface and processing capabilities. Consequently, there are many factors to consider when creating a schematic and designing a circuit board. By following the recommendations in this design guide, your confidence will increase that the board will work successfully upon initial power up.

[System Design Guidelines for MSP432E4 SimpleLink™ Microcontrollers](#)

8 器件和文档支持

8.1 入门和后续步骤

TI 提供大量的开发工具。下面是用于评估器件性能、生成代码和开发解决方案的工具和软件。

8.2 器件命名规则

为了指出产品开发周期所处的阶段，TI 为所有微处理器 (MPU) 和支持工具的产品型号分配了前缀。每个器件都具有以下三个前缀中的其中一个：XMS、PMS 或 MSP。这些前缀代表了产品开发的发展阶段，即从工程原型直到完全合格的生产器件和工具。

器件开发进化流程：

XMS 试验器件不一定代表最终器件的电气规范标准，并且可能不使用生产组装流程。

PMS 原型器件不一定是最终器件模型，并且不一定符合最终电气标准规范。

MSP 完全合格的器件模型的生产版本。

试验器件和工具在供货时附带如下免责声明：

“开发中的产品用于内部评估用途。”

生产器件和开发支持工具已进行完全特性描述，并且器件的质量和可靠性已经完全论证。TI 的标准保修证书适用。

预测显示原型器件的故障率大于标准生产器件。由于这些器件的预计最终使用故障率仍未定义，德州仪器 (TI) 建议不要将它们用于任何生产系统。只有合格的产品器件将被使用。

TI 器件的命名规则也包括一个带有器件系列名称的后缀。这个后缀表示封装类型（例如，ZAD）和温度范围（例如，“空白”是默认的商业级温度范围）。图 8-1 显示了完整器件名称的解读图例。

有关器件的订购部件号，请参阅本文档的封装选项附录、ti.com.cn 或者与您的 TI 销售代表联系。

有关裸片器件命名规则标记的其他说明，请参阅具体器件的《器件勘误表》。

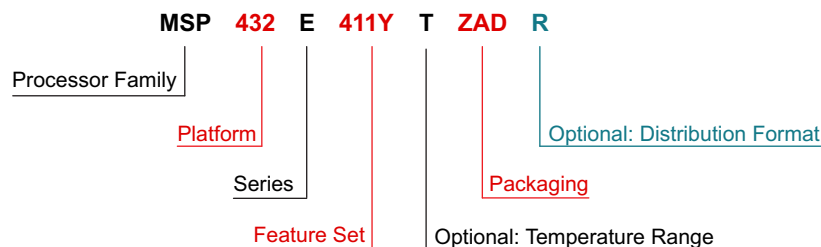

Processor Family	MSP = Mixed-Signal Processor XMS = Experimental Silicon			
Platform	432 = TI's 32-Bit Low-Power Microcontroller Platform			
Series	E = Ethernet and Wired Connectivity Series			
Feature Set	First Digit 4 = Flash-based devices up to 120 MHz	Second Digit 1 = LCD 0 = No LCD	Third Digit 1 = ADC 0 = No ADC	Fourth Digit Y = 1MB Flash
Optional: Temperature Range	T = -40°C to 105°C			
Packaging	http://www.ti.com/packaging			
Optional: Distribution Format	T = Small reel R = Large reel No markings = Tube or tray			

图 8-1. 器件命名规则

8.3 工具和软件

设计套件与评估模块

MSP432E401Y SimpleLink 微控制器 LaunchPad 开发套件 SimpleLink 以太网 MSP432E401Y 微控制器 LaunchPad 开发套件是一款适用于基于 SimpleLink Arm Cortex-M4F 以太网微控制器的低成本评估平台。以太网 LaunchPad 开发套件设计的重点突出了 MSP432E401Y 微控制器及其片上 10/100 以太网 MAC 和 PHY、USB 2.0、休眠模块、运动控制脉宽调制以及大量同步串行连接。

软件

SimpleLink MSP432E4 软件开发套件 (SDK) MSP432E4 SDK 是一套综合性的软件包，可帮助工程师在德州仪器 (TI) MSP432E4 MCU 上快速开发功能强大的应用。MSP432E4 SDK 由多个兼容软件组件构成，其中包括 RTOS、驱动程序和中间件以及一些如何一起使用这些组件的示例。此外，还提供了各种示例来展示如何使用各功能区和各个受支持的器件，同时这些示例还可用作您自己的项目的起点。

开发工具

适用于 MSP 微控制器的 Code Composer Studio™ 集成开发环境 Code Composer Studio 是一种集成开发环境 (IDE)，支持所有 MSP430 和 SimpleLink MSP432 微控制器器件。Code Composer Studio 包含一整套开发和调试嵌入式应用的嵌入式软件实用程序。它包含了优化的 C/C++ 编译器、源代码编辑器、项目构建环境、调试器、描述器以及其他多种功能。借助集成式 TI 资源浏览器，您可以访问适用于您的器件和开发板的更多示例、库、可执行代码和文档。有关更多信息，请参阅《适用于 SimpleLink™ MSP432™ 微控制器的 Code Composer Studio™ IDE 用户指南》。

IAR 嵌入式工作平台 Kickstart 适用于 MSP 的 IAR 嵌入式工作平台 Kickstart 是一套完整的调试器和 C/C++ 编译器工具链，可用于构建和调试基于 MSP430 和 SimpleLink MSP432 微控制器的嵌入式应用。MSP430 器件和 MSP432 器件的 C/C++ 编译器代码尺寸限制分别为 8KB 和 32KB。有关更多信息，请参阅《适用于 SimpleLink™ MSP432™ 微控制器的 IAR Embedded Workbench® for ARM® 用户指南》。

Arm® Keil® MDK – 免费 32KB IDE Arm Keil MDK 是一套完整的调试器和 C/C++ 编译器工具链，可用于构建和调试嵌入式应用。Keil MDK 支持低功耗和高性能 SimpleLink MSP432 MCU 系列，并且它还包括一个全集成调试器，适用于源代码级调试和反汇编级调试，支持复杂代码和数据断点。对于此 IDE，SimpleLink MSP432 软件开发套件 (SDK) 中仅支持非 RTOS 示例。有关更多信息，请参阅《适用于 SimpleLink™ MSP432™ 微控制器的 Arm® Keil® MDK 用户指南》。

MSP432E CMSIS 器件系列软件包 TI 为 MSP432E 器件提供了符合 CMSIS 标准的器件系列软件包。该软件包将 MSP432E 器件支持添加到 IAR EWArm 8.x、Keil MDK 5.x 和 Atollic True Studio 7.x。在 IAR EWArm 中，该软件包是可选的，因为 IDE 本身便支持这些器件。

适用于 MSP432 的调试器 根据设计，SimpleLink MSP432E MCU 可与 TI 及第三方供应商的各种调试器结合使用。MSP-FET 不支持 MSP432E 器件系列。

8.4 文档支持

如需接收文档更新通知，请访问 ti.com 上的器件产品文件夹。单击右上角的 [通知我进行注册](#)，即可每周接收产品信息更改摘要。有关更改的详细信息，请查看任何已修订文档中包含的修订历史记录。

以下文档描述了 MCU、相关外设和其他技术材料。

勘误表

《[MSP432E4 SimpleLink™ 微控制器器件勘误表](#)》介绍与已发布的规格不同的器件行为

应用报告

《[SimpleLink™ MSP432E4 微控制器的系统设计指南](#)》SimpleLink MSP432E4 微控制器是高度集成的片上系统 (SOC) 器件，具有扩展接口和处理功能。因此，在创建原理图和设计电路板时要考虑很多因素。通过采用本设计指南中的建议，您会更有信心，设计的电路板在首次加电时就可以有效工作。

《[在 SimpleLink MSP432E4 微控制器上使用 I²C 主机的功能集](#)》内部集成电路 (I²C) 是一个多主多从单端总线，通常用于将速度较低的外设 IC 连接到处理器和微控制器。从器件涵盖从非易失性存储器到数据采集器件在内的各类型器件，如模数转换器 (ADC)、传感器等。本应用报告展示了如何在 SimpleLink MSP432E4 微控制器上使用功能丰富的 I²C 主机与系统中的多个从器件通信。

《[通过 JTAG 接口使用 SimpleLink MSP432E4 微控制器](#)》IEEE 标准 1149.1 - 1990、IEEE 标准测试访问端口和边界扫描架构 (JTAG) 是一种用于验证设计和测试组装后的印刷电路板的方法。它是将数据传输到嵌入式系统的非易失性存储器和调试嵌入式软件的主要手段。本应用报告介绍了 JTAG 的物理连接和设计自定义电路板时需要考虑的注意事项。它还说明了如何使用 SimpleLink MSP432E4 LaunchPad 开发套件上的 JTAG 接口，以通过外部调试器调试板载微控制器，或使用板载调试器调试非板载微控制器。

用户指南

《[MSP432E4 SimpleLink™ 微控制器技术参考手册](#)》介绍 MSP432E4 系列微控制器，包括围绕 Arm Cortex-M4F 内核设计的片上系统 (SoC) 器件的功能块。

《[MSP432E4 SimpleLink™ 微控制器引导加载程序用户指南](#)》引导加载程序是一小段代码，可以编程到闪存的开始位置，以使用作应用加载程序。也可以用作在 SimpleLink MSP432E4 基于 Arm Cortex-M4 的微控制器上运行的应用的更新机制。引导加载程序可以搭建为使用 UART、SSI、I²C、CAN、以太网或 USB 端口来更新微控制器上的代码。通过源代码修改，或者简单地在编译时决定要包括的例程，可以定制引导加载程序。由于提供了完整源代码，因此引导加载程序可完全自定义。

8.5 Community Resources

下列链接提供到 TI 社区资源的连接。链接的内容由各个分销商“按照原样”提供。这些内容并不构成 TI 技术规范，并且不一定反映 TI 的观点；请参阅 TI 的《使用条款》。

TI E2E™ 在线社区 为了促进工程师之间的合作，我们创建了 TI 工程师对工程师 (E2E) 社区。在 e2e.ti.com 中，您可以提问、分享知识、拓展思路并与同行工程师一道帮助解决问题。

TI Embedded Processors Wiki Established to help developers get started with Embedded Processors from Texas Instruments and to foster innovation and growth of general knowledge about the hardware and software surrounding these devices.

8.6 商标

SimpleLink, LaunchPad, MSP432, E2E are trademarks of Texas Instruments.
ARM, Cortex, Thumb, Thumb-2, PrimeCell, Arm7 are registered trademarks of Arm Limited.
Bluetooth is a registered trademark of Bluetooth SIG.
Wi-Fi is a registered trademark of Wi-Fi Alliance.
All other trademarks are the property of their respective owners.

8.7 静电放电警告



ESD 可能会损坏该集成电路。德州仪器 (TI) 建议通过适当的预防措施处理所有集成电路。如果不遵守正确的处理措施和安装程序，可能会损坏集成电路。

ESD 的损坏小至导致微小的性能降级，大至整个器件故障。精密的集成电路可能更容易受到损坏，这是因为非常细微的参数更改都可能会导致器件与其发布的规格不相符。

8.8 出口管制提示

接收方同意：如果美国或其他适用法律限制或禁止将通过非披露义务的披露方获得的任何产品或技术数据（其中包括软件）（见美国、欧盟和其他出口管理条例之定义）、或者其他适用国家条例限制的任何受管制产品或此项技术的任何直接产品出口或再出口至任何目的地，那么在没有事先获得美国商务部和其他相关政府机构授权的情况下，接收方不得在知情的情况下，以直接或间接的方式将其出口。



8.9 术语表

TI 术语表 这份术语表列出并解释术语、缩写和定义。

9 机械、封装和可订购信息

以下页面包含机械、封装和可订购信息。这些信息是指定器件的最新可用数据。数据如有变更，恕不另行通知和修订此文档。如欲获取此数据表的浏览器版本，请参阅左侧的导航。

PACKAGING INFORMATION

Orderable Device	Status (1)	Package Type	Package Drawing	Pins	Package Qty	Eco Plan (2)	Lead finish/ Ball material (6)	MSL Peak Temp (3)	Op Temp (°C)	Device Marking (4/5)	Samples
MSP432E401YTPDT	ACTIVE	TQFP	PDT	128	90	RoHS & Green	NIPDAU	Level-3-260C-168 HR	-40 to 105	MSP432 E401YT	
MSP432E401YTPDTR	ACTIVE	TQFP	PDT	128	1000	RoHS & Green	NIPDAU	Level-3-260C-168 HR	-40 to 105	MSP432 E401YT	

(1) The marketing status values are defined as follows:

ACTIVE: Product device recommended for new designs.

LIFEBUY: TI has announced that the device will be discontinued, and a lifetime-buy period is in effect.

NRND: Not recommended for new designs. Device is in production to support existing customers, but TI does not recommend using this part in a new design.

PREVIEW: Device has been announced but is not in production. Samples may or may not be available.

OBSOLETE: TI has discontinued the production of the device.

(2) **RoHS:** TI defines "RoHS" to mean semiconductor products that are compliant with the current EU RoHS requirements for all 10 RoHS substances, including the requirement that RoHS substance do not exceed 0.1% by weight in homogeneous materials. Where designed to be soldered at high temperatures, "RoHS" products are suitable for use in specified lead-free processes. TI may reference these types of products as "Pb-Free".

RoHS Exempt: TI defines "RoHS Exempt" to mean products that contain lead but are compliant with EU RoHS pursuant to a specific EU RoHS exemption.

Green: TI defines "Green" to mean the content of Chlorine (Cl) and Bromine (Br) based flame retardants meet JS709B low halogen requirements of <=1000ppm threshold. Antimony trioxide based flame retardants must also meet the <=1000ppm threshold requirement.

(3) MSL, Peak Temp. - The Moisture Sensitivity Level rating according to the JEDEC industry standard classifications, and peak solder temperature.

(4) There may be additional marking, which relates to the logo, the lot trace code information, or the environmental category on the device.

(5) Multiple Device Markings will be inside parentheses. Only one Device Marking contained in parentheses and separated by a "~" will appear on a device. If a line is indented then it is a continuation of the previous line and the two combined represent the entire Device Marking for that device.

(6) Lead finish/Ball material - Orderable Devices may have multiple material finish options. Finish options are separated by a vertical ruled line. Lead finish/Ball material values may wrap to two lines if the finish value exceeds the maximum column width.

Important Information and Disclaimer: The information provided on this page represents TI's knowledge and belief as of the date that it is provided. TI bases its knowledge and belief on information provided by third parties, and makes no representation or warranty as to the accuracy of such information. Efforts are underway to better integrate information from third parties. TI has taken and continues to take reasonable steps to provide representative and accurate information but may not have conducted destructive testing or chemical analysis on incoming materials and chemicals. TI and TI suppliers consider certain information to be proprietary, and thus CAS numbers and other limited information may not be available for release.

In no event shall TI's liability arising out of such information exceed the total purchase price of the TI part(s) at issue in this document sold by TI to Customer on an annual basis.

PDT (S-PQFP-G128)

PLASTIC QUAD FLATPACK

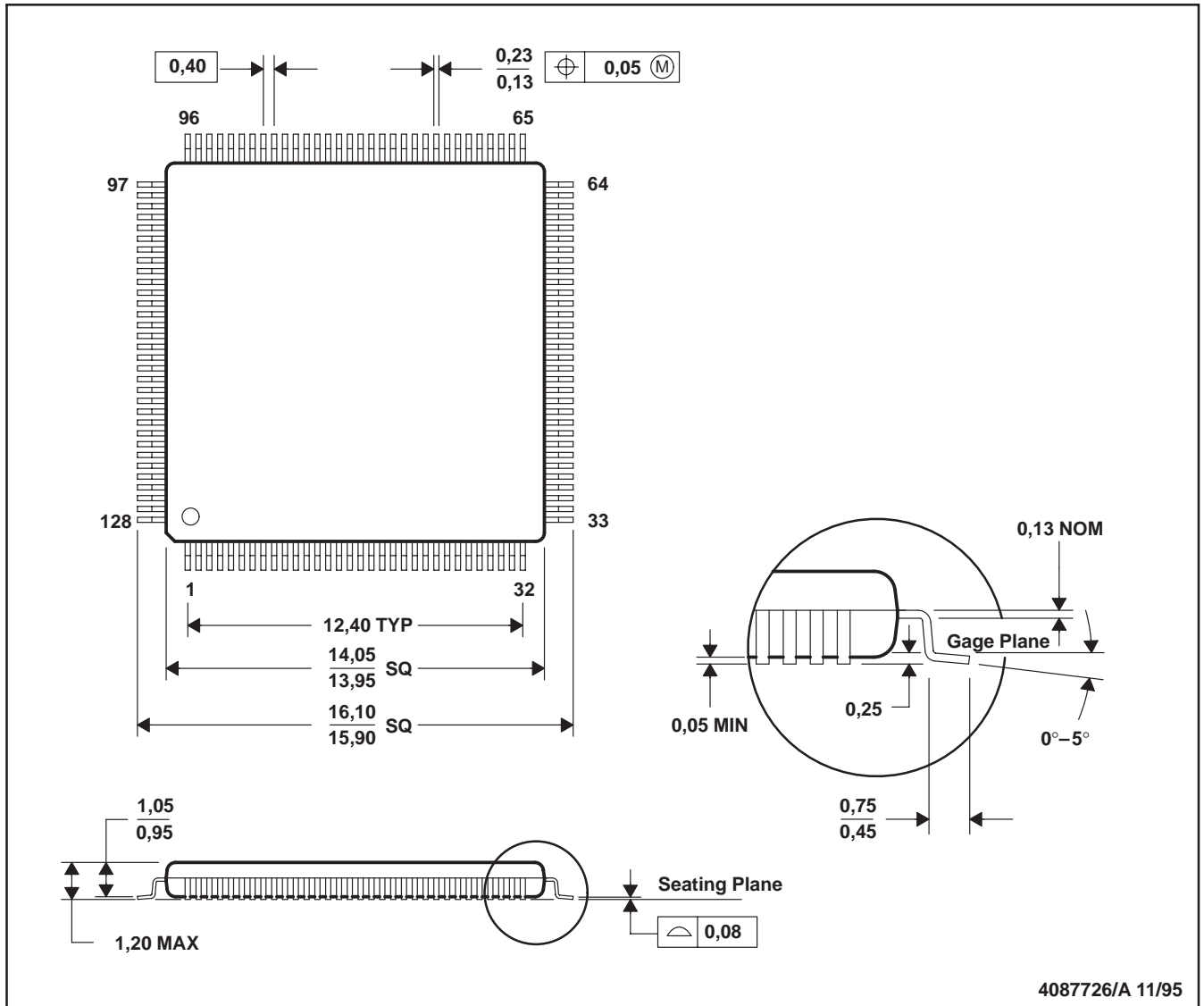

- NOTES: A. All linear dimensions are in millimeters.
 B. This drawing is subject to change without notice.

PDT (S-PQFP-G128)

PLASTIC QUAD FLAT PACK

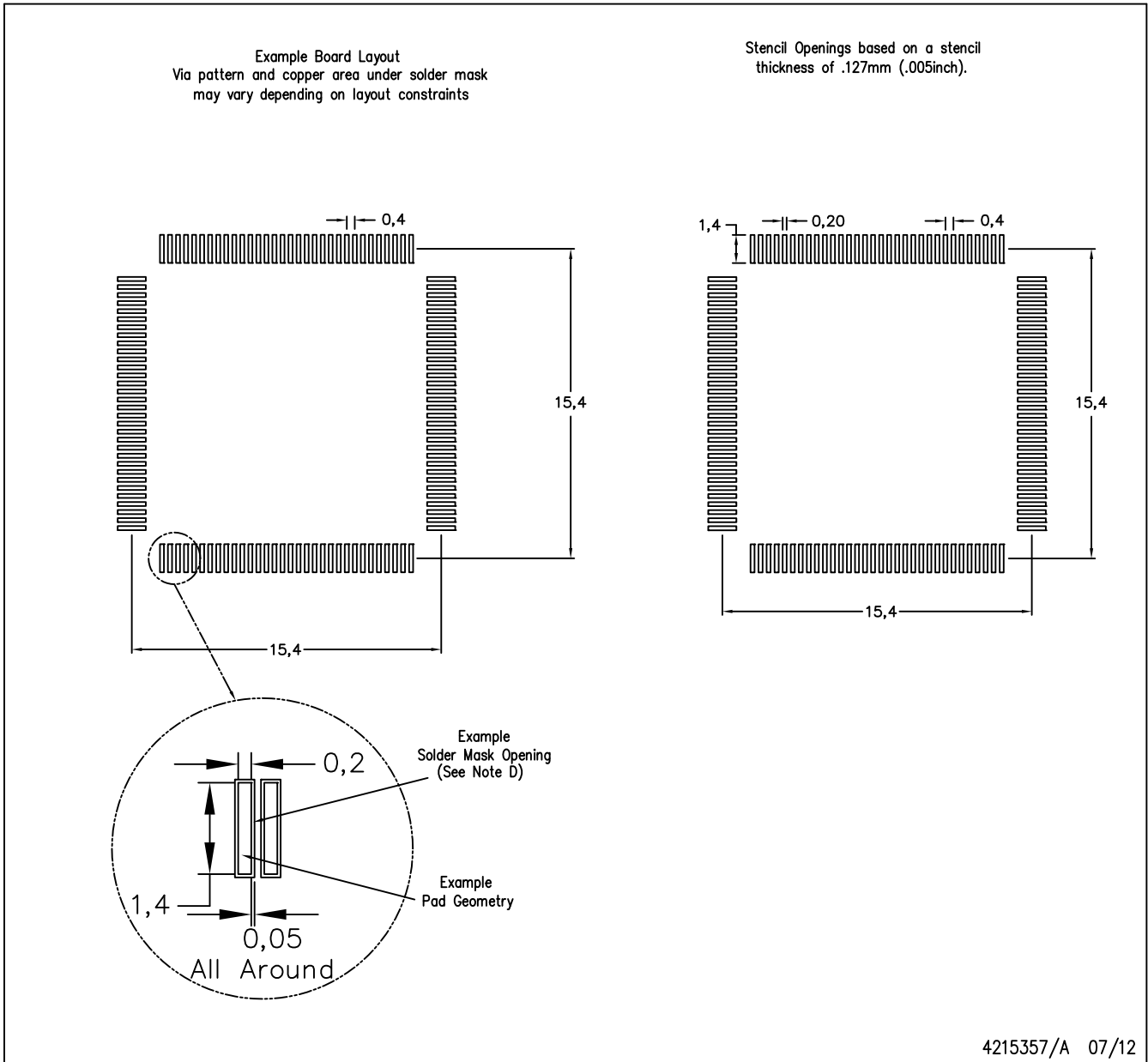

- NOTES:
- A. All linear dimensions are in millimeters.
 - B. This drawing is subject to change without notice.
 - C. Laser cutting apertures with trapezoidal walls and also rounding corners will offer better paste release. Customers should contact their board assembly site for stencil design recommendations. Example stencil metal load solder paste. Refer to IPC-7525 for other stencil recommendations.
 - D. Customers should contact their board fabrication site for solder mask tolerances between and around signal pads.

重要声明和免责声明

TI 均以“原样”提供技术性及其可靠性数据（包括数据表）、设计资源（包括参考设计）、应用或其他设计建议、网络工具、安全信息和其他资源，不保证其中不含任何瑕疵，且不做任何明示或暗示的担保，包括但不限于对适销性、适合某特定用途或不侵犯任何第三方知识产权的暗示担保。

所述资源可供专业开发人员应用TI 产品进行设计使用。您将对以下行为独自承担全部责任：(1) 针对您的应用选择合适的TI 产品；(2) 设计、验证并测试您的应用；(3) 确保您的应用满足相应标准以及任何其他安全、安保或其他要求。所述资源如有变更，恕不另行通知。TI 对您使用所述资源的授权仅限于开发资源所涉及TI 产品的相关应用。除此之外不得复制或展示所述资源，也不提供其它TI 或任何第三方的知识产权授权许可。如因使用所述资源而产生任何索赔、赔偿、成本、损失及债务等，TI 对此概不负责，并且您须赔偿由此对TI 及其代表造成的损害。

TI 所提供产品均受TI 的销售条款 (<http://www.ti.com.cn/zh-cn/legal/termsofsale.html>) 以及ti.com.cn上或随附TI产品提供的其他可适用条款的约束。TI提供所述资源并不扩展或以其他方式更改TI 针对TI 产品所发布的可适用的担保范围或担保免责声明。

邮寄地址：上海市浦东新区世纪大道 1568 号中建大厦 32 楼，邮政编码：200122

Copyright © 2020 德州仪器半导体技术（上海）有限公司