

## 具有 $\pm 12\text{V}$ 单端输入和 $\pm 4\text{V}$ 差分输出的 ISO224 增强型隔离放大器

### 1 特性

- 提供高级 (ISO224B) 与低级 (ISO224A) 两个版本
- $\pm 12\text{V}$  输入电压范围针对工业应用中的隔离式电压测量进行了优化
- 9kV 静电放电 (ESD) 过压输入钳位
- $\pm 4\text{V}$  差分输出电压范围, 共模电压为  $V_{DD2}/2$
- 低直流误差运行 (ISO224B):
  - 输入失调电压:  $25^\circ\text{C}$  时为  $\pm 5\text{mV}$ ,  $\pm 15\mu\text{V}/^\circ\text{C}$  (最大值)
  - 增益误差:  $25^\circ\text{C}$  时为  $\pm 0.3\%$ ,  $\pm 35\text{ppm}/^\circ\text{C}$  (最大值)
  - 非线性度:  $\pm 0.01\%$  (最大值),  $\pm 0.1\text{ppm}/^\circ\text{C}$  (典型值)
- 4.5V 至 18V 高侧单电源
- 4.5V 至 5.5V 低侧运行
- 安全相关认证:
  - 7071  $V_{PEAK}$  增强型隔离, 符合 DIN VDE V 0884-11: 2017-01 标准
  - 5000  $V_{RMS}$  隔离, 符合 UL1577 标准且持续时间为 1 分钟
- 高 CMTI (ISO224B):  $80\text{kV}/\mu\text{s}$  (典型值)

### 2 应用

- 在以下领域进行隔离模拟信号采集:
  - 电网自动化
  - 保护继电器
  - 工厂自动化与控制
  - 铁路运输
  - 电机驱动器
  - 功率分析仪

### 3 说明

ISO224 是一款精密的隔离放大器, 此放大器的输出与输入电路由抗电磁干扰性能极强的隔离栅隔开。该隔离栅经认证, 可提供高达  $5\text{kV}_{RMS}$  的增强型电隔离, 使用寿命极长, 功率耗散较低。与隔离式电源结合使用时, 该器件可将以不同共模电压电平运行的系统的各器件隔离, 并防止较低电压器件损坏。

ISO224 的输入专门针对精确检测  $\pm 10\text{V}$  信号进行了优化, 该信号在工业应用当中十分普遍。该器件由高侧单电源供电运行。此独有的特性可简化隔离式电源的设计, 降低系统成本。集成的高侧电源电压检测功能可简化系统级诊断。ISO224 的  $\pm 4\text{V}$  输出可支持使用更低成本的模数转换器 (ADC)。输出的差分结构具有更强的抗噪性能。

ISO224 可在  $-55^\circ\text{C}$  至  $+125^\circ\text{C}$  的扩展工业温度范围内正常运行, 并采用宽体 8 引脚 SOIC (DWV) 封装。

器件信息<sup>(1)</sup>

器件名称	封装	封装尺寸
ISO224	SOIC (8)	5.85mm × 7.5mm

(1) 如需了解所有可用封装, 请参阅数据表末尾的可订购产品附录。

简化原理图

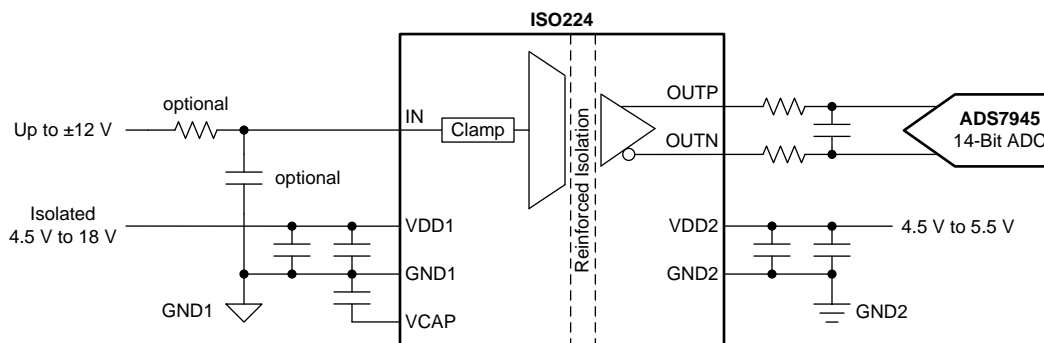

## 目录

<p><b>1 特性</b> ..... 1</p> <p><b>2 应用</b> ..... 1</p> <p><b>3 说明</b> ..... 1</p> <p><b>4 修订历史记录</b> ..... 2</p> <p><b>5 器件比较表</b> ..... 3</p> <p><b>6 Pin Configuration and Functions</b> ..... 3</p> <p><b>7 Specifications</b> ..... 4</p> <p>    7.1 Absolute Maximum Ratings ..... 4</p> <p>    7.2 ESD Ratings ..... 4</p> <p>    7.3 Recommended Operating Conditions ..... 4</p> <p>    7.4 Thermal Information ..... 5</p> <p>    7.5 Power Ratings ..... 5</p> <p>    7.6 Insulation Specifications ..... 6</p> <p>    7.7 Safety-Related Certifications ..... 7</p> <p>    7.8 Safety Limiting Values ..... 7</p> <p>    7.9 Electrical Characteristics ..... 7</p> <p>    7.10 Switching Characteristics ..... 9</p> <p>    7.11 Insulation Characteristics Curves ..... 10</p> <p>    7.12 Typical Characteristics ..... 11</p> <p><b>8 Detailed Description</b> ..... 17</p>	<p>    8.1 Overview ..... 17</p> <p>    8.2 Functional Block Diagram ..... 17</p> <p>    8.3 Feature Description ..... 18</p> <p>    8.4 Device Functional Modes ..... 21</p> <p><b>9 Application and Implementation</b> ..... 22</p> <p>    9.1 Application Information ..... 22</p> <p>    9.2 Typical Application ..... 22</p> <p>    9.3 What to Do and What Not to Do ..... 24</p> <p><b>10 Power Supply Recommendations</b> ..... 25</p> <p><b>11 Layout</b> ..... 26</p> <p>    11.1 Layout Guidelines ..... 26</p> <p>    11.2 Layout Example ..... 26</p> <p><b>12 器件和文档支持</b> ..... 27</p> <p>    12.1 文档支持 ..... 27</p> <p>    12.2 接收文档更新通知 ..... 27</p> <p>    12.3 社区资源 ..... 27</p> <p>    12.4 商标 ..... 27</p> <p>    12.5 静电放电警告 ..... 27</p> <p>    12.6 术语表 ..... 27</p> <p><b>13 机械、封装和可订购信息</b> ..... 28</p>
---	---

## 4 修订历史记录

Changes from Original (June 2018) to Revision A	Page
• 已更改 将文档状态从“预告信息”更改成了“生产数据” .....	1

## 5 器件比较表

参数	ISO224B	ISO224A
输入失调电压, $V_{OS}$	$\pm 5\text{mV}$ (最大值)	$\pm 50\text{mV}$ (最大值)
输入失调电压温漂, $TCV_{OS}$	$\pm 15\mu\text{V}/^\circ\text{C}$ (最大值)	$\pm 60\mu\text{V}/^\circ\text{C}$ (最大值)
输入参考噪声	$3\mu\text{V}/\sqrt{\text{Hz}}$ (典型值)	$4\mu\text{V}/\sqrt{\text{Hz}}$ (典型值)
增益误差, $E_G$	$\pm 0.3\%$ (最大值)	$\pm 1\%$ (最大值)
增益误差漂移, $TCE_G$	$\pm 35\text{ppm}/^\circ\text{C}$ (最大值)	$\pm 60\text{ppm}/^\circ\text{C}$ (最大值)
非线性度	$\pm 0.01\%$ (最大值)	$\pm 0.02\%$ (最大值)
输出带宽, BW	275kHz (典型值)	185kHz (典型值)
共模瞬态抗扰度, CMTI	80kV/ $\mu\text{s}$ (典型值)	30kV/ $\mu\text{s}$ (典型值)
输入到输出, OUTN 信号延迟 (50% – 50%)	2.2 $\mu\text{s}$ (典型值)	2.8 $\mu\text{s}$ (典型值)

## 6 Pin Configuration and Functions

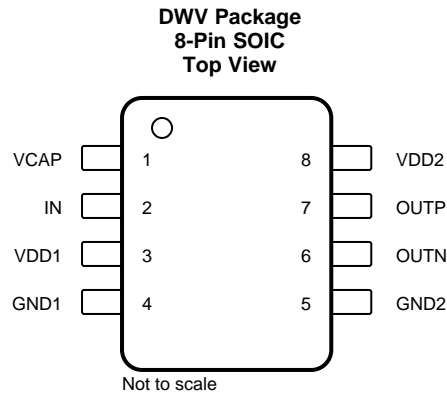

### Pin Functions

PIN		I/O	DESCRIPTION
NO.	NAME		
1	VCAP	—	Supply decoupling capacitor. Connect a 0.22- $\mu\text{F}$ capacitor between this pin and the high-side analog ground.
2	IN	I	Analog input
3	VDD1	—	High-side power supply, 4.5 V to 18 V. See the <a href="#">Power Supply Recommendations</a> section for decoupling recommendations.
4	GND1	—	High-side analog ground
5	GND2	—	Low-side analog ground
6	OUTN	O	Inverting analog output
7	OUTP	O	Noninverting analog output
8	VDD2	—	Low-side power supply, 4.5 V to 5.5 V. See the <a href="#">Power Supply Recommendations</a> section for decoupling recommendations.

## 7 Specifications

### 7.1 Absolute Maximum Ratings

 see <sup>(1)</sup>

		MIN	MAX	UNIT
Power-supply voltage	VDD1 to GND1	-0.3	26	V
	VDD2 to GND2	-0.3	6.5	
Input voltage	IN to GND1 <sup>(2)</sup>	-15	15	V
Input current	Continuous, at IN pin <sup>(3)</sup>	-10	10	mA
Output voltage	OUTP, OUTN	GND2 - 0.3	VDD2 + 0.3	V
Temperature	Junction, T <sub>J</sub>		150	°C
	Storage, T <sub>stg</sub>	-65	150	

- (1) Stresses beyond those listed under *Absolute Maximum Ratings* may cause permanent damage to the device. These are stress ratings only, which do not imply functional operation of the device at these or any other conditions beyond those indicated under *Recommended Operating Conditions*. Exposure to absolute-maximum-rated conditions for extended periods may affect device reliability.
- (2) Exposure to absolute-maximum-rated condition for extended periods may increase input leakage current.
- (3) Limit the input current at IN pin to prevent permanent damage to the device. The IN pin is internally protected by a voltage clamp. See [Figure 42](#) for a typical current versus voltage characteristic curve of the input clamp.

### 7.2 ESD Ratings

			VALUE	UNIT	
V <sub>(ESD)</sub>	Electrostatic discharge	Human-body model (HBM), per ANSI/ESDA/JEDEC JS-001 <sup>(1)</sup>	IN pin only	±9000	V
			All pins except IN	±3000	
		Charged-device model (CDM), per JEDEC specification JESD22-C101 <sup>(2)</sup>	±1000		

- (1) JEDEC document JEP155 states that 500-V HBM allows safe manufacturing with a standard ESD control process.
- (2) JEDEC document JEP157 states that 250-V CDM allows safe manufacturing with a standard ESD control process.

### 7.3 Recommended Operating Conditions

over operating ambient temperature range (unless otherwise noted)

			MIN	NOM	MAX	UNIT
<b>POWER SUPPLY</b>						
	High-side power supply	VDD1 to GND1	4.5	5	18	V
	Low-side power supply	VDD2 to GND2	4.5	5	5.5	V
<b>ANALOG INPUT</b>						
V <sub>Clipping</sub>	Input voltage before clipping output <sup>(1)</sup>	IN to GND1		±13.8		V
V <sub>FSR</sub>	Specified linear input full-scale voltage <sup>(1)</sup>	IN to GND1	-12		12	V
<b>TEMPERATURE RANGE</b>						
T <sub>A</sub>	Specified ambient temperature		-55	25	125	°C

- (1) See the [Analog Input](#) section for more details.

## 7.4 Thermal Information

THERMAL METRIC <sup>(1)</sup>		ISO224x	UNIT
		DWV (SOIC)	
		8 PINS	
$R_{\theta JA}$	Junction-to-ambient thermal resistance	96.3	°C/W
$R_{\theta JC(top)}$	Junction-to-case (top) thermal resistance	36.9	°C/W
$R_{\theta JB}$	Junction-to-board thermal resistance	60.1	°C/W
$\Psi_{JT}$	Junction-to-top characterization parameter	16.9	°C/W
$\Psi_{JB}$	Junction-to-board characterization parameter	58.2	°C/W
$R_{\theta JC(bot)}$	Junction-to-case (bottom) thermal resistance	n/a	°C/W

(1) For more information about traditional and new thermal metrics, see the [Semiconductor and IC Package Thermal Metrics](#) application report.

## 7.5 Power Ratings<sup>(1)</sup>

PARAMETER		TEST CONDITIONS	VALUE	UNIT
$P_D$	Maximum power dissipation (both sides)	VDD1 = 18 V, VDD2 = 5.5 V	194.9	mW
		VDD1 = VDD2 = 5.5 V	97.4	
$P_{D1}$	Maximum power dissipation (high-side supply)	VDD1 = 18 V	140.4	mW
		VDD1 = 5.5 V	42.9	
$P_{D2}$	Maximum power dissipation (low-side supply)	VDD2 = 5.5 V	54.5	mW

(1) See the [Electrical Characteristics](#) table for maximum supply current specifications.

## 7.6 Insulation Specifications

over operating ambient temperature range (unless otherwise noted)

PARAMETER		TEST CONDITIONS	VALUE	UNIT
<b>GENERAL</b>				
CLR	External clearance <sup>(1)</sup>	Shortest pin-to-pin distance through air	≥ 8.5	mm
CPG	External creepage <sup>(1)</sup>	Shortest pin-to-pin distance across the package surface	≥ 8.5	mm
DTI	Distance through insulation	Minimum internal gap (internal clearance) of the double insulation	≥ 0.021	mm
CTI	Comparative tracking index	DIN EN 60112 (VDE 0303-11); IEC 60112	≥ 600	V
	Material group	According to IEC 60664-1	I	
	Overvoltage category per IEC 60664-1	Rated mains voltage ≤ 600 V <sub>RMS</sub>	I-IV	
		Rated mains voltage ≤ 1000 V <sub>RMS</sub>	I-III	
<b>DIN VDE V 0884-11 (VDE V 0884-11): 2017-01<sup>(2)</sup></b>				
V <sub>IORM</sub>	Maximum repetitive peak isolation voltage	At AC voltage (bipolar or unipolar)	2121	V <sub>PK</sub>
V <sub>IOWM</sub>	Maximum-rated isolation working voltage	At AC voltage (sine wave); time dependent dielectric breakdown (TDDB) test; see <a href="#">Fig 4</a>	1500	V <sub>RMS</sub>
		At DC voltage	2121	V <sub>DC</sub>
V <sub>IOTM</sub>	Maximum transient isolation voltage	V <sub>TEST</sub> = V <sub>IOTM</sub> , t = 60 s (qualification test)	7071	V <sub>PK</sub>
		V <sub>TEST</sub> = 1.2 × V <sub>IOTM</sub> , t = 1 s (100% production test)	8485	
V <sub>IOSM</sub>	Maximum surge isolation voltage <sup>(3)</sup>	Test method per IEC 60065, 1.2/50-μs waveform, V <sub>TEST</sub> = 1.6 × V <sub>IOSM</sub> = 12800 V <sub>PK</sub> (qualification)	8000	V <sub>PK</sub>
q <sub>pd</sub>	Apparent charge <sup>(4)</sup>	Method A, after input/output safety test subgroup 2/3, V <sub>ini</sub> = V <sub>IOTM</sub> , t <sub>ini</sub> = 60 s, V <sub>pd(m)</sub> = 1.2 × V <sub>IORM</sub> = 2545 V <sub>PK</sub> , t <sub>m</sub> = 10 s	≤ 5	pC
		Method A, after environmental tests subgroup 1, V <sub>ini</sub> = V <sub>IOTM</sub> , t <sub>ini</sub> = 60 s, V <sub>pd(m)</sub> = 1.6 × V <sub>IORM</sub> = 3394 V <sub>PK</sub> , t <sub>m</sub> = 10 s	≤ 5	
		Method B1, at routine test (100% production) and preconditioning (type test), V <sub>ini</sub> = V <sub>IOTM</sub> , t <sub>ini</sub> = 1 s, V <sub>pd(m)</sub> = 1.875 × V <sub>IORM</sub> = 3977 V <sub>PK</sub> , t <sub>m</sub> = 1 s	≤ 5	
C <sub>IO</sub>	Barrier capacitance, input to output <sup>(5)</sup>	V <sub>IO</sub> = 0.5 V <sub>PP</sub> at 1 MHz	~1	pF
R <sub>IO</sub>	Insulation resistance, input to output <sup>(5)</sup>	V <sub>IO</sub> = 500 V at T <sub>A</sub> = 25°C	> 10 <sup>12</sup>	Ω
		V <sub>IO</sub> = 500 V at 100°C ≤ T <sub>A</sub> ≤ 125°C	> 10 <sup>11</sup>	
		V <sub>IO</sub> = 500 V at T <sub>S</sub> = 150°C	> 10 <sup>9</sup>	
	Pollution degree		2	
	Climatic category		55/125/21	
<b>UL1577</b>				
V <sub>ISO</sub>	Withstand isolation voltage	V <sub>TEST</sub> = V <sub>ISO</sub> = 5000 V <sub>RMS</sub> or 7071 V <sub>DC</sub> , t = 60 s (qualification), V <sub>TEST</sub> = 1.2 × V <sub>ISO</sub> = 6000 V <sub>RMS</sub> , t = 1 s (100% production test)	5000	V <sub>RMS</sub>

- (1) Apply creepage and clearance requirements according to the specific equipment isolation standards of an application. Care must be taken to maintain the creepage and clearance distance of a board design to ensure that the mounting pads of the isolator on the printed circuit board (PCB) do not reduce this distance. Creepage and clearance on a PCB become equal in certain cases. Techniques such as inserting grooves and ribs on the PCB are used to help increase these specifications.
- (2) This coupler is suitable for *safe electrical insulation* only within the safety ratings. Compliance with the safety ratings shall be ensured by means of suitable protective circuits.
- (3) Testing is carried out in air or oil to determine the intrinsic surge immunity of the isolation barrier.
- (4) Apparent charge is electrical discharge caused by a partial discharge (pd).
- (5) All pins on each side of the barrier are tied together, creating a two-pin device.

## 7.7 Safety-Related Certifications

VDE	UL
Certified according to DIN VDE V 0884-11 (VDE V 0884-11): 2017-01, DIN EN 60950-1 (VDE 0805 Teil 1): 2014-08, and DIN EN 60065 (VDE 0860): 2005-11	Recognized under 1577 component recognition and CSA component acceptance NO 5 programs
Reinforced insulation	Single protection
File number: 40040142	File number: E181974

## 7.8 Safety Limiting Values

Safety limiting intends to minimize potential damage to the isolation barrier upon failure of input or output circuitry.

PARAMETER		TEST CONDITIONS	MIN	TYP	MAX	UNIT
I <sub>S</sub>	Safety input, output, or supply current	R <sub>θJA</sub> = 96.3°C/W, T <sub>J</sub> = 150°C, T <sub>A</sub> = 25°C, VDD1 = 18 V, VDD2 = 5.5 V, see <a href="#">Figure 2</a>			55	mA
		R <sub>θJA</sub> = 96.3°C/W, T <sub>J</sub> = 150°C, T <sub>A</sub> = 25°C, VDD1 = VDD2 = 5.5 V, see <a href="#">Figure 2</a>			236	
P <sub>S</sub>	Safety input, output, or total power	R <sub>θJA</sub> = 96.3°C/W, T <sub>J</sub> = 150°C, T <sub>A</sub> = 25°C, see <a href="#">Figure 3</a>			1298 <sup>(1)</sup>	mW
T <sub>S</sub>	Maximum safety temperature				150	°C

- (1) The maximum safety temperature, T<sub>S</sub>, has the same value as the maximum junction temperature, T<sub>J</sub>, specified for the device. The I<sub>S</sub> and P<sub>S</sub> parameters represent the safety current and safety power, respectively. Do not exceed the maximum limits of I<sub>S</sub> and P<sub>S</sub>. These limits vary with the ambient temperature, T<sub>A</sub>.

The junction-to-air thermal resistance, R<sub>θJA</sub>, in the [Thermal Information](#) table is that of a device installed on a high-K test board for leaded surface-mount packages. Use these equations to calculate the value for each parameter:

$T_J = T_A + R_{\theta JA} \times P$ , where P is the power dissipated in the device.

$T_{J(max)} = T_S = T_A + R_{\theta JA} \times P_S$ , where T<sub>J(max)</sub> is the maximum junction temperature.

$P_S = I_S \times VDD1_{max} + I_S \times VDD2_{max}$ , where VDD1<sub>max</sub> is the maximum high-side supply voltage and VDD2<sub>max</sub> is the maximum low-side supply voltage.

## 7.9 Electrical Characteristics

minimum and maximum specifications apply from T<sub>A</sub> = –55°C to +125°C, VDD1 = 4.5 V to 18 V, VDD2 = 4.5 V to 5.5 V, V<sub>IN</sub> = –12 V to 12 V, and R<sub>LOAD</sub> = 10 kΩ; typical specifications are at T<sub>A</sub> = 25°C, and VDD1 = VDD2 = 5 V (unless otherwise noted)

PARAMETER		TEST CONDITIONS	MIN	TYP	MAX	UNIT
<b>ANALOG INPUT</b>						
V <sub>OS</sub>	Input offset voltage <sup>(1)</sup>	Initial, at T <sub>A</sub> = 25°C, IN = GND1, ISO224B	–5	±1	5	mV
		Initial, at T <sub>A</sub> = 25°C, IN = GND1, ISO224A	–50	±1	50	
TCV <sub>OS</sub>	Input offset voltage drift <sup>(1)</sup>	ISO224B	–15	±3	15	μV/°C
		ISO224A	–60	±12	60	
C <sub>IN</sub>	Input capacitance	IN to GND1		2		pF
R <sub>IN</sub>	Input resistance	IN to GND1	1	1.25		MΩ
I <sub>IB</sub>	Input bias current	IN = GND1		±15		nA
TCl <sub>IB</sub>	Input bias current drift	IN = GND1		±30		pA/°C
e <sub>n</sub>	Input-referred noise density	ISO224B		3		μV/√Hz
		ISO224A		4		

- (1) The typical value includes one sigma statistical variation.

**Electrical Characteristics (continued)**

minimum and maximum specifications apply from  $T_A = -55^\circ\text{C}$  to  $+125^\circ\text{C}$ ,  $V_{DD1} = 4.5\text{ V}$  to  $18\text{ V}$ ,  $V_{DD2} = 4.5\text{ V}$  to  $5.5\text{ V}$ ,  $V_{IN} = -12\text{ V}$  to  $12\text{ V}$ , and  $R_{LOAD} = 10\text{ k}\Omega$ ; typical specifications are at  $T_A = 25^\circ\text{C}$ , and  $V_{DD1} = V_{DD2} = 5\text{ V}$  (unless otherwise noted)

PARAMETER		TEST CONDITIONS	MIN	TYP	MAX	UNIT
<b>ANALOG OUTPUTS</b>						
	Nominal gain	$(V_{OUTP} - V_{OUTN}) / V_{IN}$		1/3		V/V
$E_G$	Gain error <sup>(1)</sup>	Initial, at $T_A = 25^\circ\text{C}$ , ISO224B	-0.3%	$\pm 0.05\%$	0.3%	
		Initial, at $T_A = 25^\circ\text{C}$ , ISO224A	-1%	0.4%	1%	
$TCE_G$	Gain error drift <sup>(1)</sup>	ISO224B	-35	$\pm 10$	35	ppm/ $^\circ\text{C}$
		ISO224A	-60	$\pm 20$	60	
	Nonlinearity	ISO224B	-0.01%	$\pm 0.003\%$	0.01%	
		ISO224A	-0.02%	$\pm 0.003\%$	0.02%	
	Nonlinearity drift			$\pm 0.1$		ppm/ $^\circ\text{C}$
THD	Total harmonic distortion	$f_{IN} = 10\text{ kHz}$		-84		dB
	Output noise	IN = GND1, $f_{IN} = 0\text{ Hz}$ , BW = 10 kHz		300		$\mu\text{V}_{\text{RMS}}$
		IN = GND1, $f_{IN} = 0\text{ Hz}$ , BW = 100 kHz		360		
PSRR	Power-supply rejection ratio <sup>(2)</sup>	vs $V_{DD1}$ , at DC		-107		dB
		vs $V_{DD1}$ , 100-mV and 10-kHz ripple		-101		
		vs $V_{DD2}$ , at DC		-71		
		vs $V_{DD2}$ , 100-mV and 10-kHz ripple		-56		
$V_{OUT}$	Output voltage	OUTP or OUTN to GND2	GND2 + 0.2		$V_{DD2} - 0.2$	V
$V_{CMout}$	Common-mode output voltage	$(V_{OUTP} + V_{OUTN}) / 2$	$0.48 \times V_{DD2}$	$V_{DD2} / 2$	$0.52 \times V_{DD2}$	V
$V_{FAILSAFE}$	Failsafe output voltage	$V_{DD1}$ missing, OUTP and OUTN forced to GND2			GND2 + 0.1	V
$I_{SC}$	Output short-circuit current	On OUTP or OUTN to GND2		$\pm 18$		mA
	Overload recovery time			5		$\mu\text{s}$
$R_{OUT}$	Output resistance	On OUTP or OUTN to GND2		< 0.5		$\Omega$
$C_{LOAD}$	Capacitive load drive <sup>(3)</sup>	On OUTP or OUTN to GND2			100	pF
		OUTP to OUTN			50	
$R_{LOAD}$	Resistive load	On OUTP or OUTN		10		k $\Omega$
BW	Small signal output bandwidth	ISO224B	220	275		kHz
		ISO224A	150	185		
CMTI	Common-mode transient immunity	$ GND1 - GND2  = 1\text{ kV}$ , ISO224B	55	80		kV/ $\mu\text{s}$
		$ GND1 - GND2  = 1\text{ kV}$ , ISO224A	15	30		
<b>POWER SUPPLY</b>						
$I_{DD1}$	High-side supply current			6.1	7.8	mA
$I_{DD2}$	Low-side supply current			7.8	9.9	mA

(2) This parameter is output referred.

(3) Use series resistor to decouple higher capacitive load.

## 7.10 Switching Characteristics

over operating ambient temperature range (unless otherwise noted)

PARAMETER	TEST CONDITIONS	MIN	TYP	MAX	UNIT
$t_r, t_f$	ISO224B on OUTP, OUTN		1.5		$\mu\text{s}$
	ISO224A on OUTP, OUTN		2		$\mu\text{s}$
IN to OUTP, OUTN signal delay (50% – 10%)	ISO224B, unfiltered output, see 图 1		1.5	2	$\mu\text{s}$
	ISO224A, unfiltered output, see 图 1		1.9	2.9	
IN to OUTP, OUTN signal delay (50% – 50%)	ISO224B, unfiltered output, see 图 1		2.2	2.7	$\mu\text{s}$
	ISO224A, unfiltered output, see 图 1		2.8	3.8	
IN to OUTP, OUTN signal delay (50% – 90%)	ISO224B, unfiltered output, see 图 1		3	3.5	$\mu\text{s}$
	ISO224A, unfiltered output, see 图 1		3.8	4.8	
$t_{AS}$	VDD1 step to 4.5 V with VDD2 $\geq$ 4.5 V, to OUTP, OUTN valid, 0.1% settling		250		$\mu\text{s}$



图 1. Delay Time Test Waveforms

### 7.11 Insulation Characteristics Curves

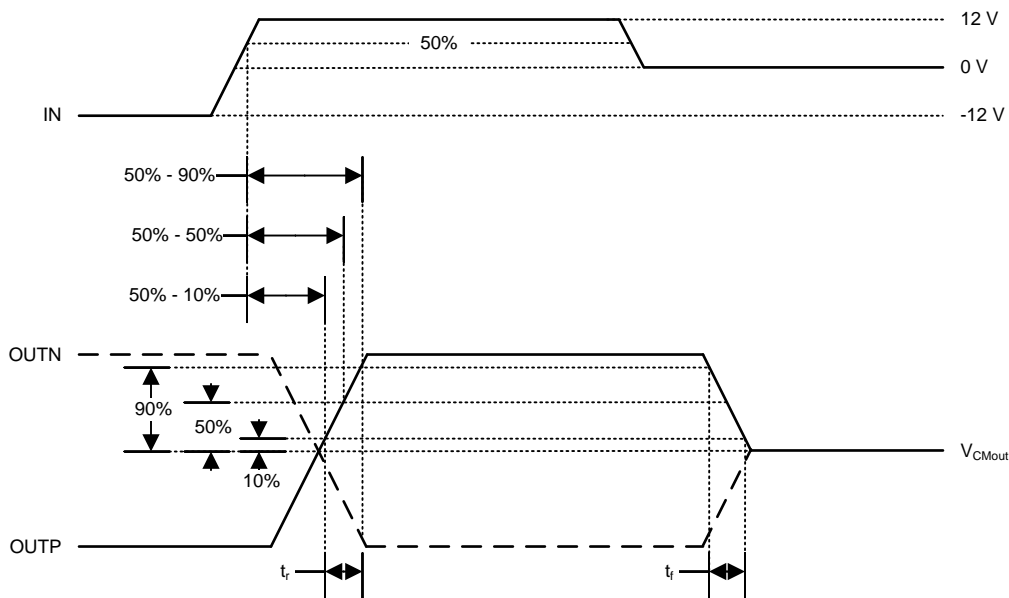

图 2. Thermal Derating Curve for Safety-Limiting Current per VDE

图 3. Thermal Derating Curve for Safety-Limiting Power per VDE

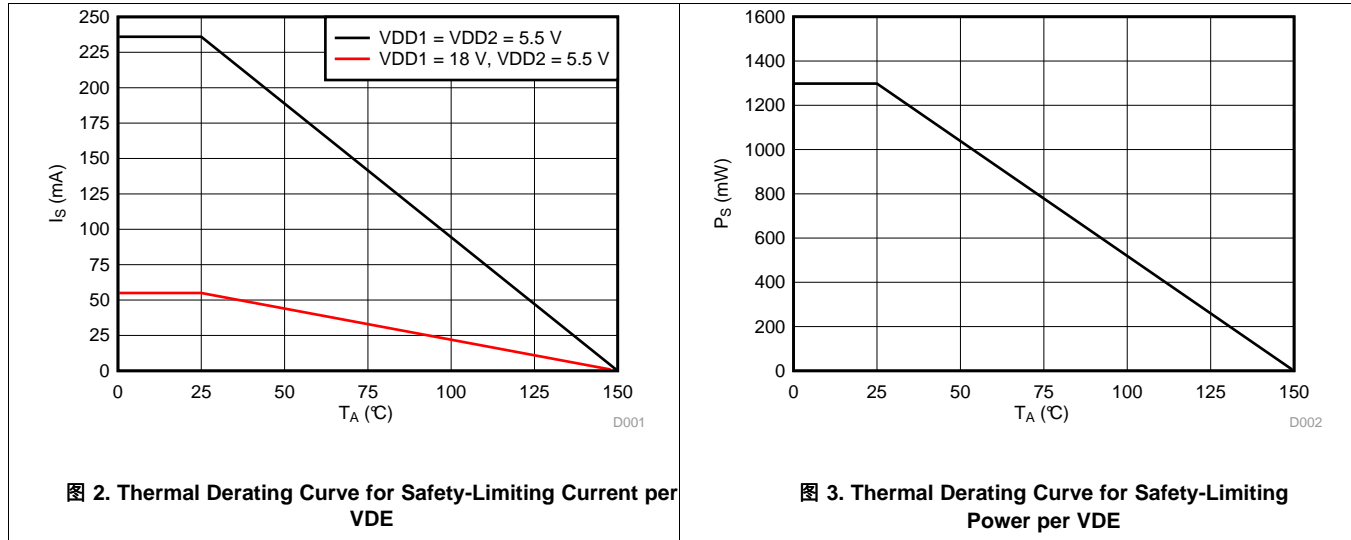

图 4. Reinforced Isolation Capacitor Lifetime Projection

### 7.12 Typical Characteristics

at  $T_A = 25^\circ\text{C}$ ,  $V_{DD1} = V_{DD2} = 5\text{ V}$ , and  $V_{INP} = -12\text{ V}$  to  $12\text{ V}$ , unless otherwise noted.

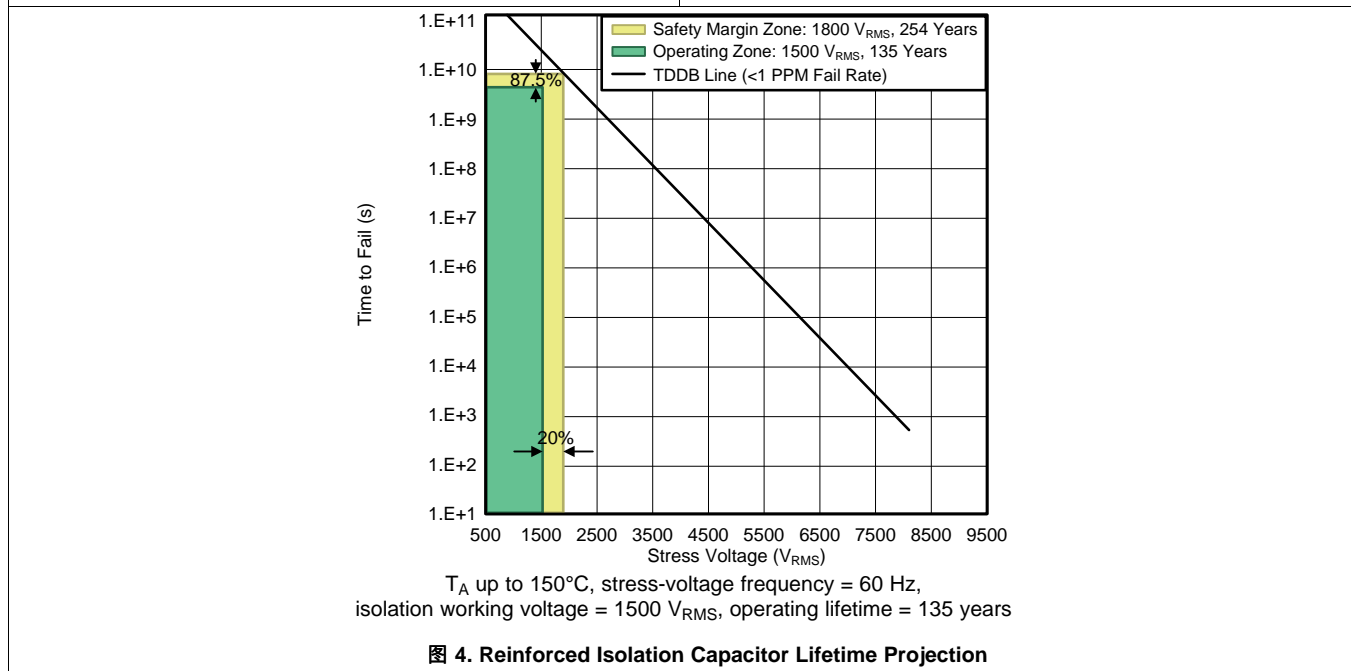

图 5. Input Offset Voltage Histogram



图 6. Input Offset Voltage vs High-Side Supply Voltage

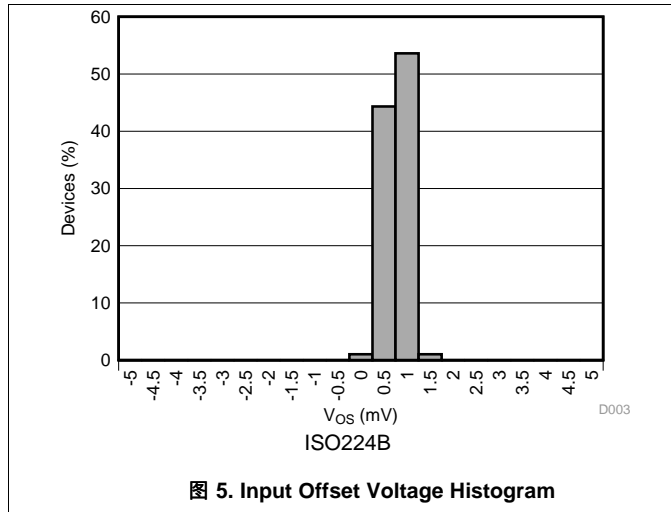

图 7. Input Offset Voltage vs Low-Side Supply Voltage

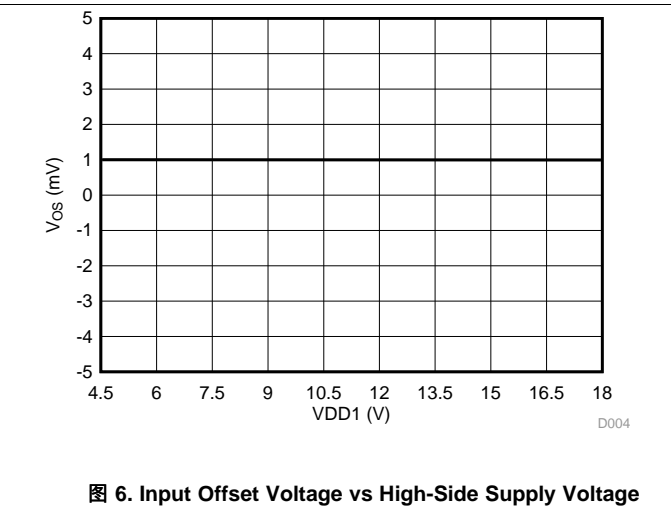

图 8. Input Offset Voltage vs Temperature

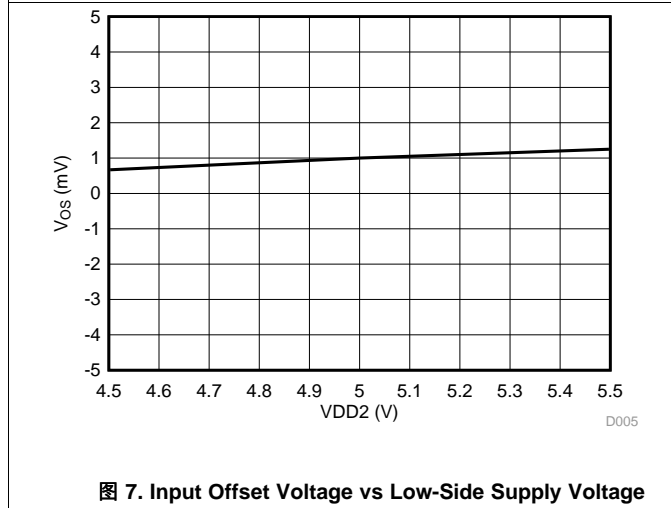

图 9. Input Offset Drift Histogram

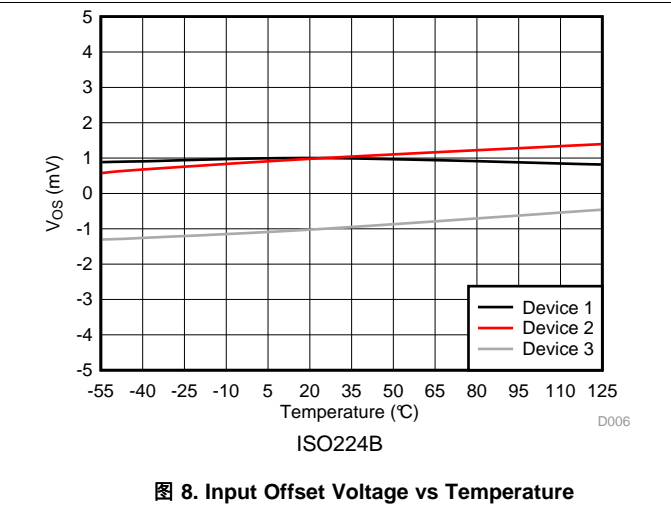

图 10. Input Bias Current vs High-Side Supply Voltage

Typical Characteristics (接下页)

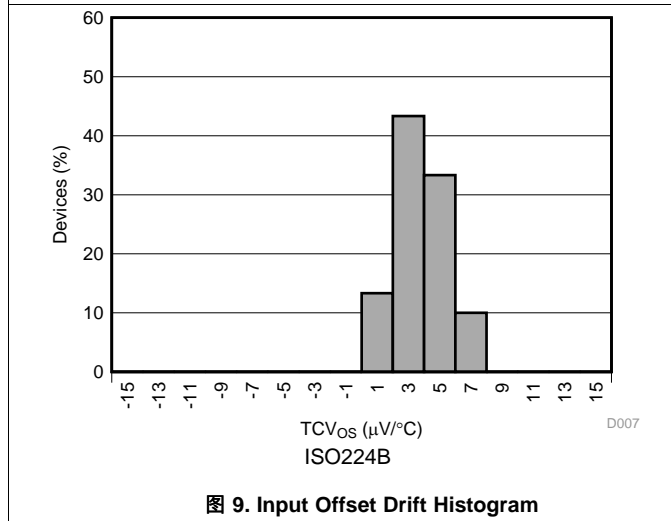
at  $T_A = 25^\circ\text{C}$ ,  $V_{DD1} = V_{DD2} = 5\text{ V}$ , and  $V_{INP} = -12\text{ V}$  to  $12\text{ V}$ , unless otherwise noted.

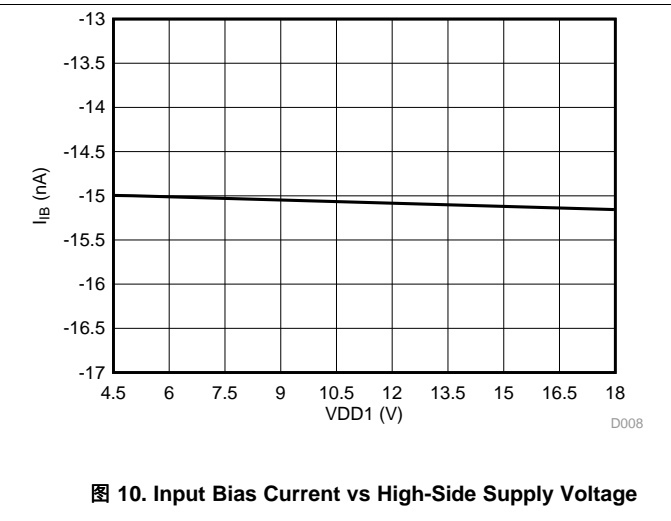
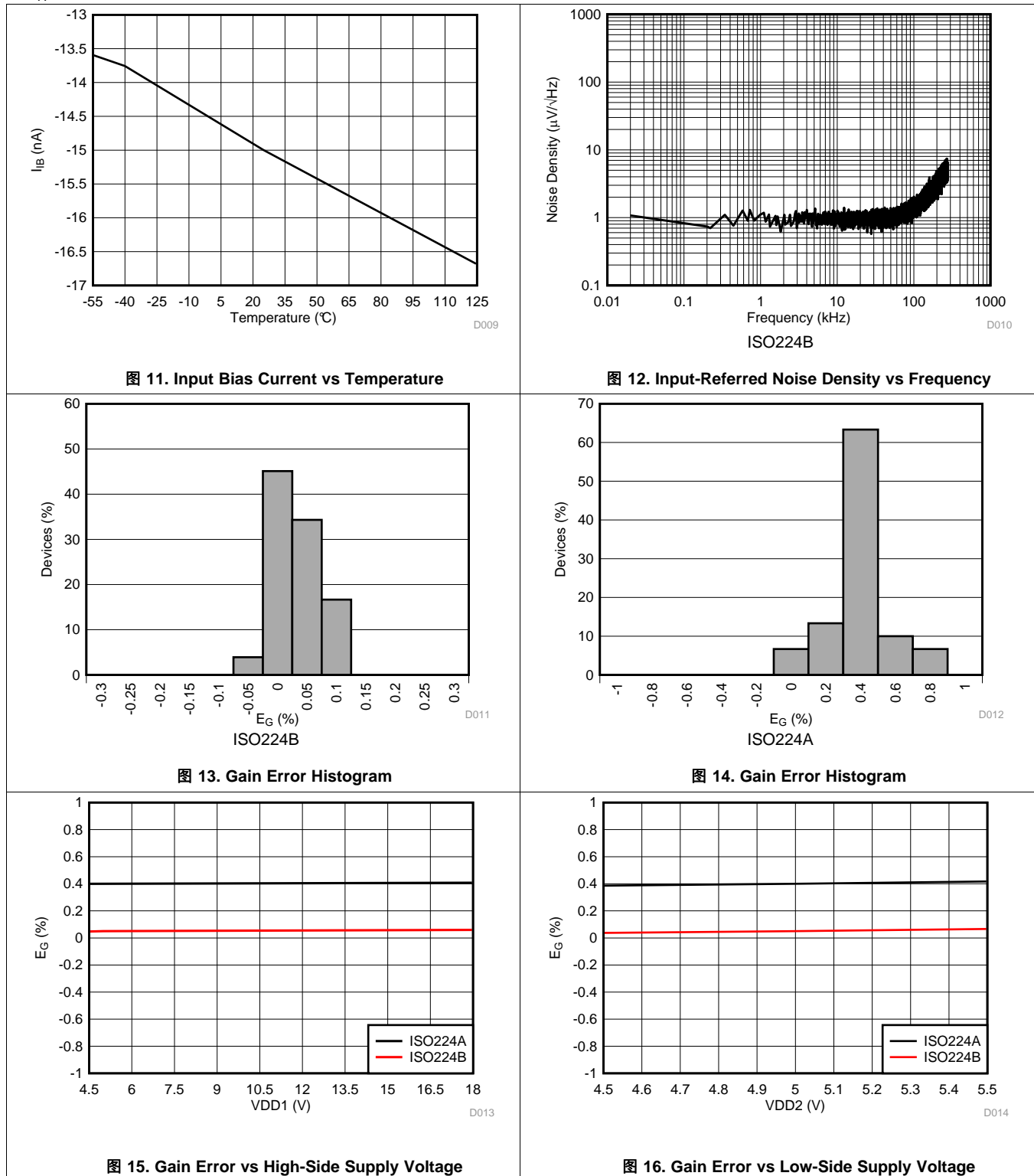

Typical Characteristics (接下页)

at  $T_A = 25^\circ\text{C}$ ,  $V_{DD1} = V_{DD2} = 5\text{ V}$ , and  $V_{INP} = -12\text{ V to } 12\text{ V}$ , unless otherwise noted.



图 17. Gain Error vs Temperature



图 18. Gain Error Drift Histogram

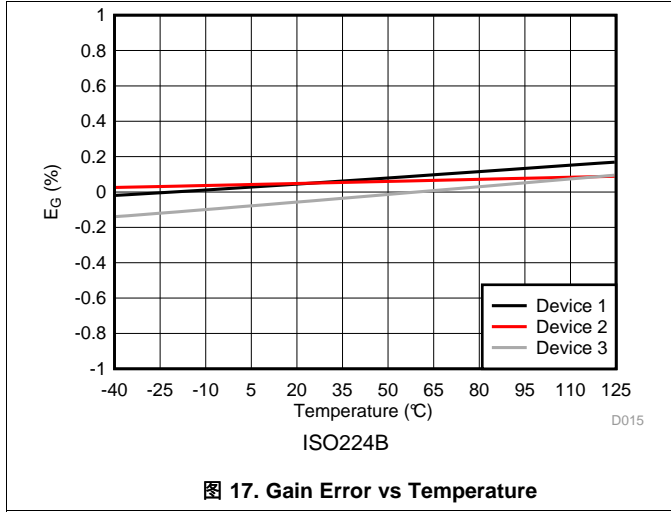

图 19. Normalized Gain vs Input Frequency

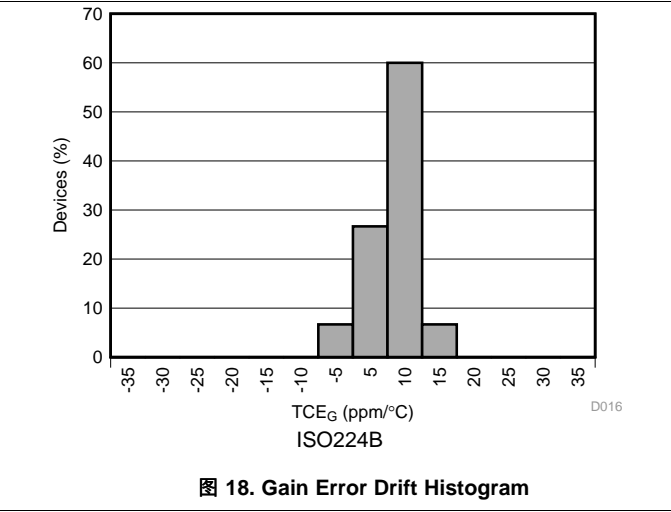

图 20. Output Phase vs Input Frequency

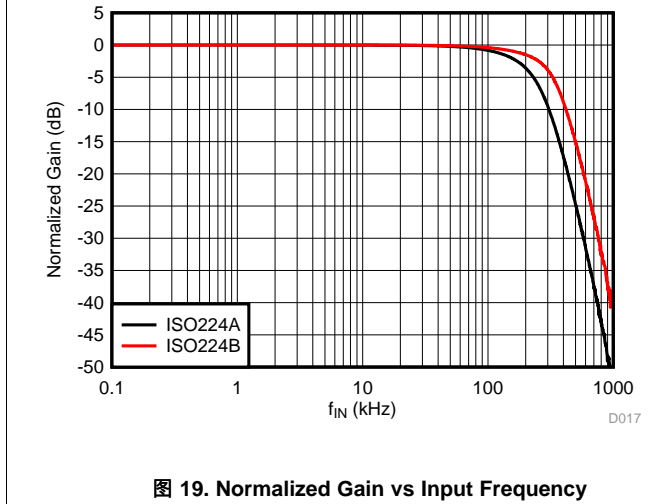

图 21. Output Voltage vs Input Voltage

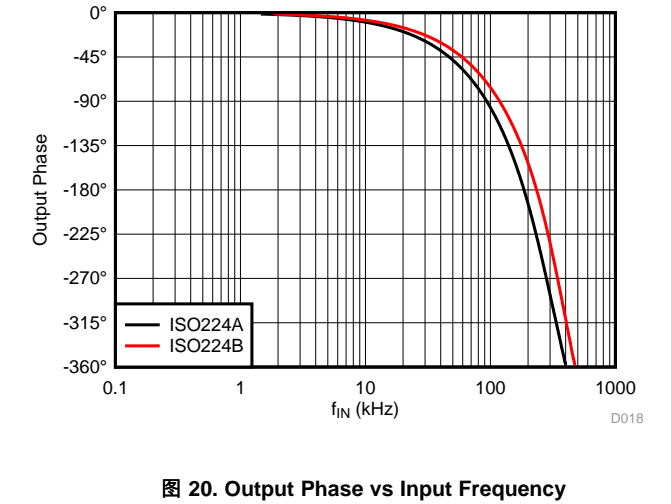

图 22. Nonlinearity vs Input Voltage

Typical Characteristics (接下页)

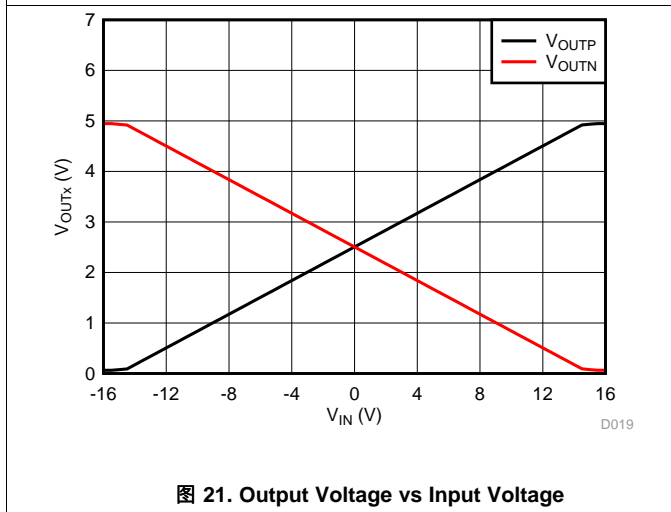
at  $T_A = 25^\circ\text{C}$ ,  $V_{DD1} = V_{DD2} = 5\text{ V}$ , and  $V_{INP} = -12\text{ V}$  to  $12\text{ V}$ , unless otherwise noted.

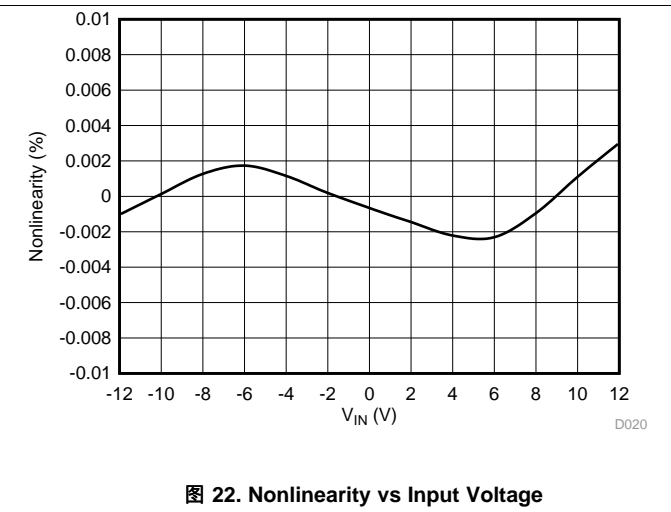
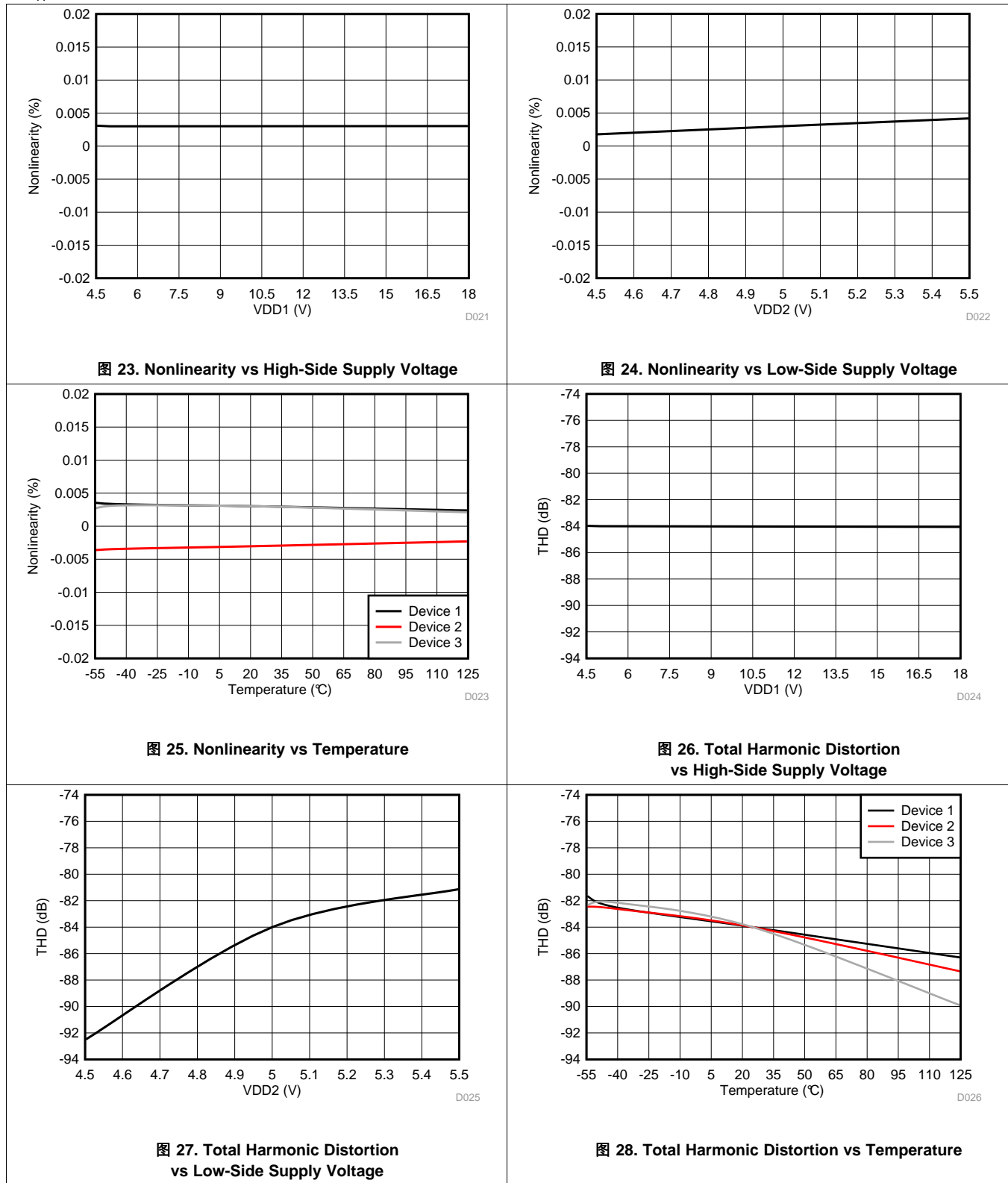

Typical Characteristics (接下页)

at  $T_A = 25^\circ\text{C}$ ,  $V_{DD1} = V_{DD2} = 5\text{ V}$ , and  $V_{INP} = -12\text{ V}$  to  $12\text{ V}$ , unless otherwise noted.

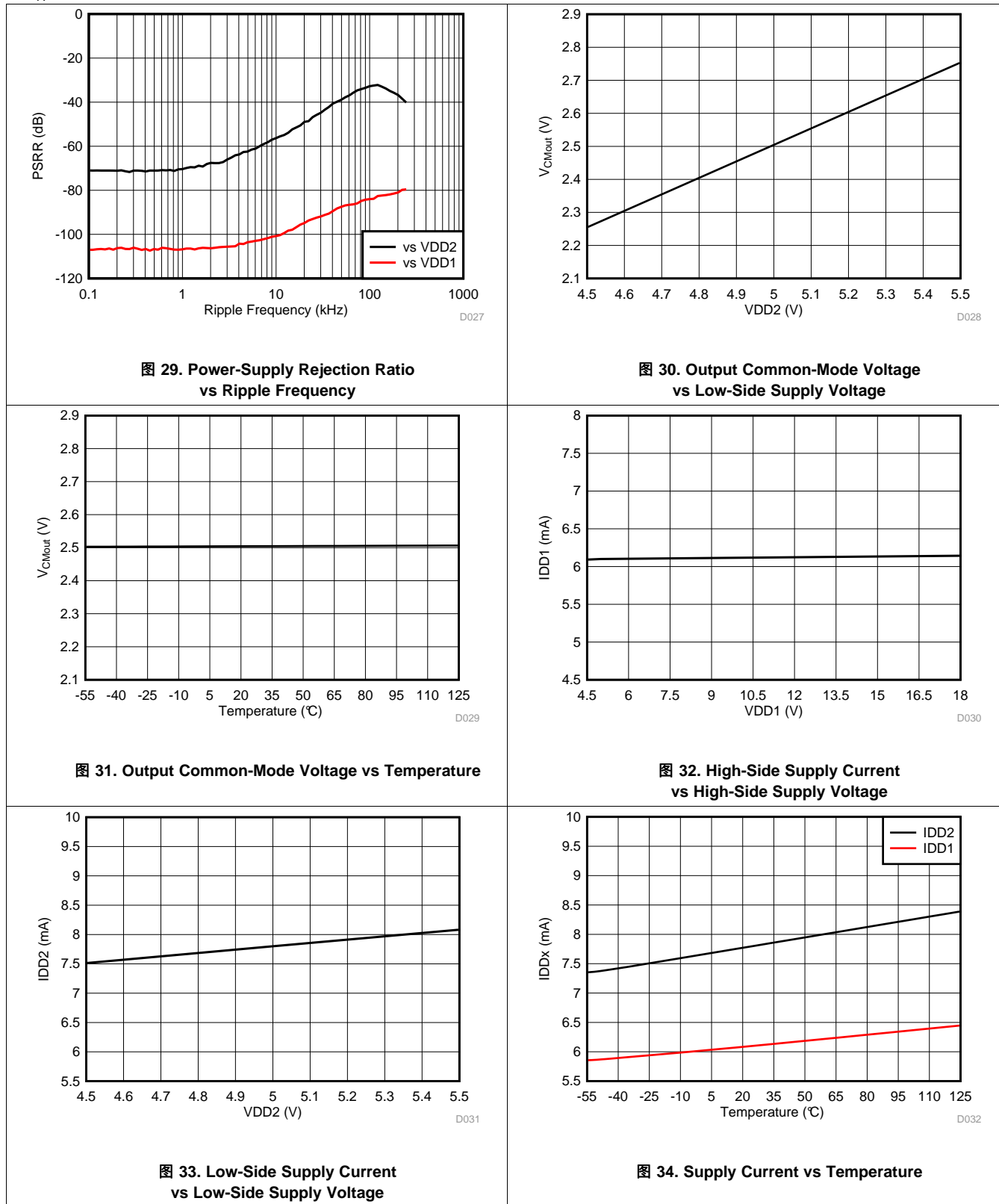

Typical Characteristics (接下页)

at  $T_A = 25^\circ\text{C}$ ,  $V_{DD1} = V_{DD2} = 5\text{ V}$ , and  $V_{INP} = -12\text{ V}$  to  $12\text{ V}$ , unless otherwise noted.

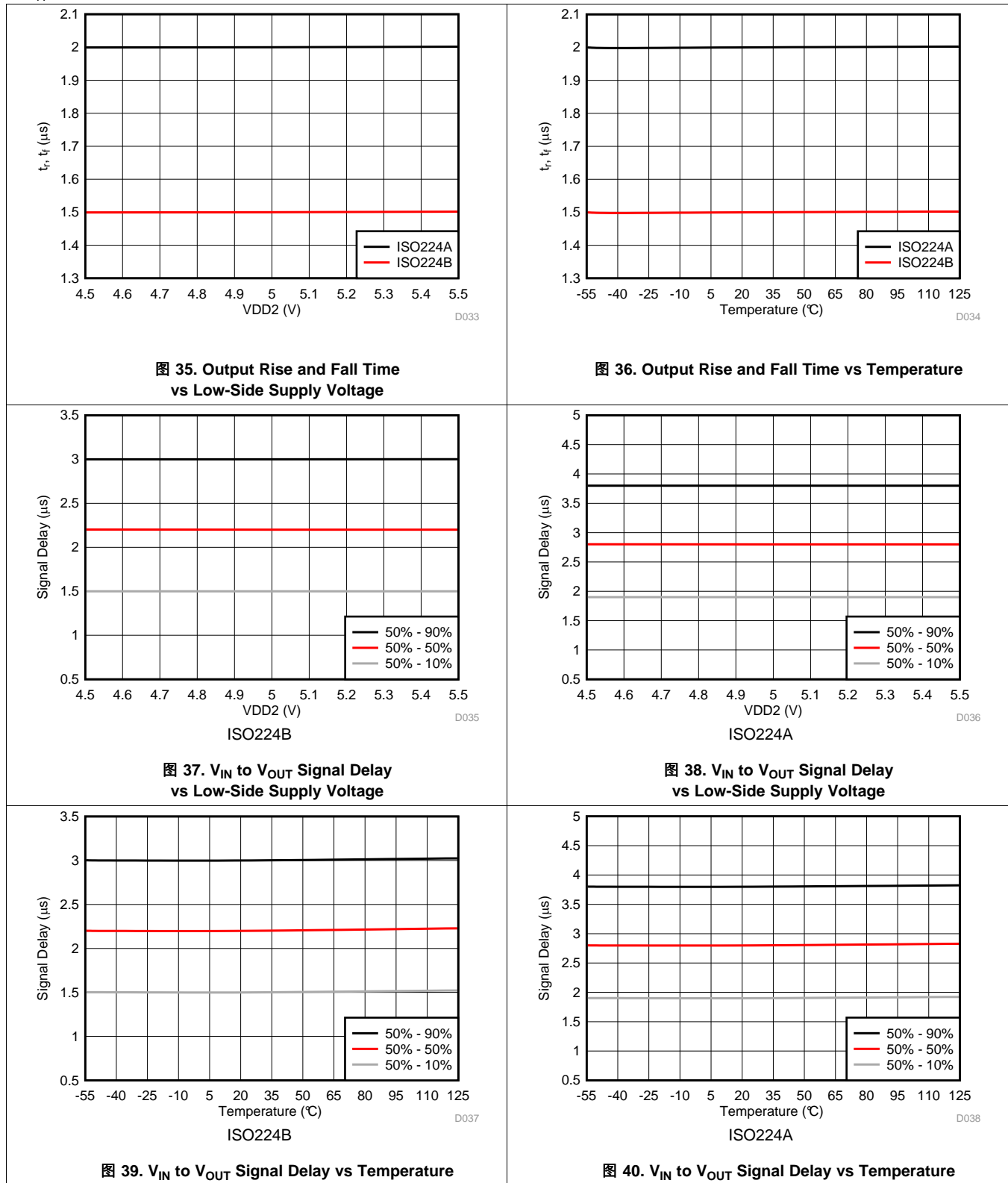

## 8 Detailed Description

### 8.1 Overview

The ISO224 is a precision, isolated amplifier with a high input impedance and wide input voltage range suitable for wide range of industrial applications. The input stage of the device drives a delta-sigma ( $\Delta\Sigma$ ) modulator. The modulator uses the internal voltage reference and clock generator to convert the analog input signal to a digital bitstream. The drivers (called TX in the *Functional Block Diagram* section) transfer the output of the modulator across the isolation barrier that separates the high-side and low-side voltage domains. The received bitstream and clock are synchronized and processed by a digital-to-analog conversion stage on the low-side and presented as a differential analog output.

The SiO<sub>2</sub>-based, double-capacitive isolation barrier supports a high level of magnetic field immunity, as described in *ISO72x Digital Isolator Magnetic-Field Immunity*. The digital modulation used in the ISO224 and the isolation barrier characteristics result in high reliability and high common-mode transient immunity.

### 8.2 Functional Block Diagram

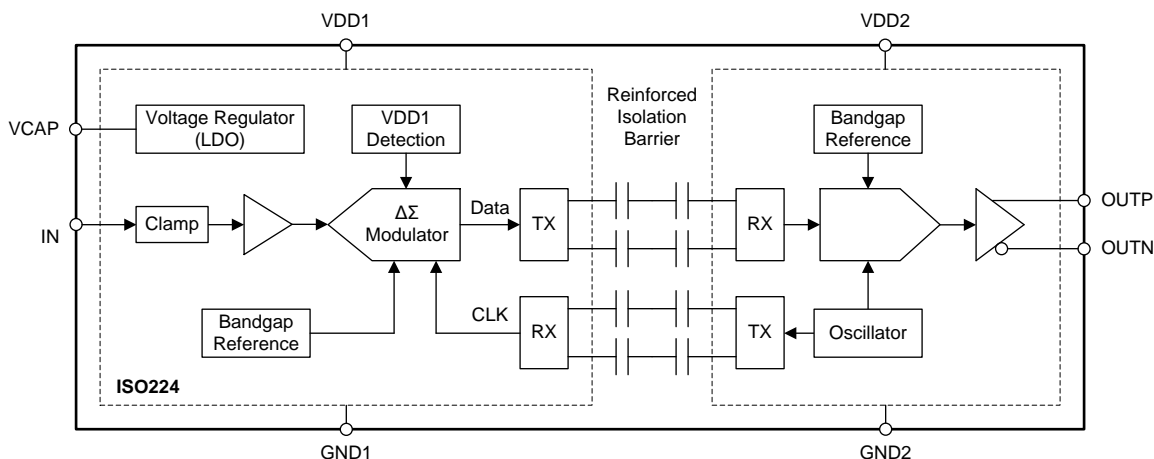

## 8.3 Feature Description

### 8.3.1 Analog Input

The input stage of the ISO224 feeds a switched capacitor, feed-forward  $\Delta\Sigma$  modulator. The modulator converts the analog signal into a bitstream that is transferred over the isolation barrier, as described in the [Isolation Channel Signal Transmission](#) section. The high-impedance and low bias-current input of the ISO224 makes the device suitable for isolated voltage sensing applications.

图 41 visualizes the difference in the transfer function of the ISO224 depending on the input signal  $V_{IN}$ , as specified in the [Recommended Operating Conditions](#) table. With the input voltage within the specified full-scale range  $V_{FSR}$ , the output of the device changes in a linear way with small error as specified by the nonlinearity parameter in the [Electrical Characteristics](#) table. If the input signal exceeds the  $V_{FSR}$  range, the nonlinearity of the output signals increases and the amplitude clips at  $V_{IN} = V_{CLIPPING}$ .



图 41. Transfer Function of the ISO224

There are two restrictions on the analog input signal at the IN pin. First, if the input voltage  $V_{IN}$  exceeds the range of  $-15\text{ V}$  to  $15\text{ V}$ , the current must be limited to  $10\text{ mA}$  to prevent damage to the input clamp, see the [Input Clamp Protection Circuit](#) section for further information. In addition, the linearity and noise performance of the ISO224 are ensured only when the analog input voltage remains within the specified linear full-scale range ( $V_{FSR}$ ).

## Feature Description (接下页)

### 8.3.2 Input Clamp Protection Circuit

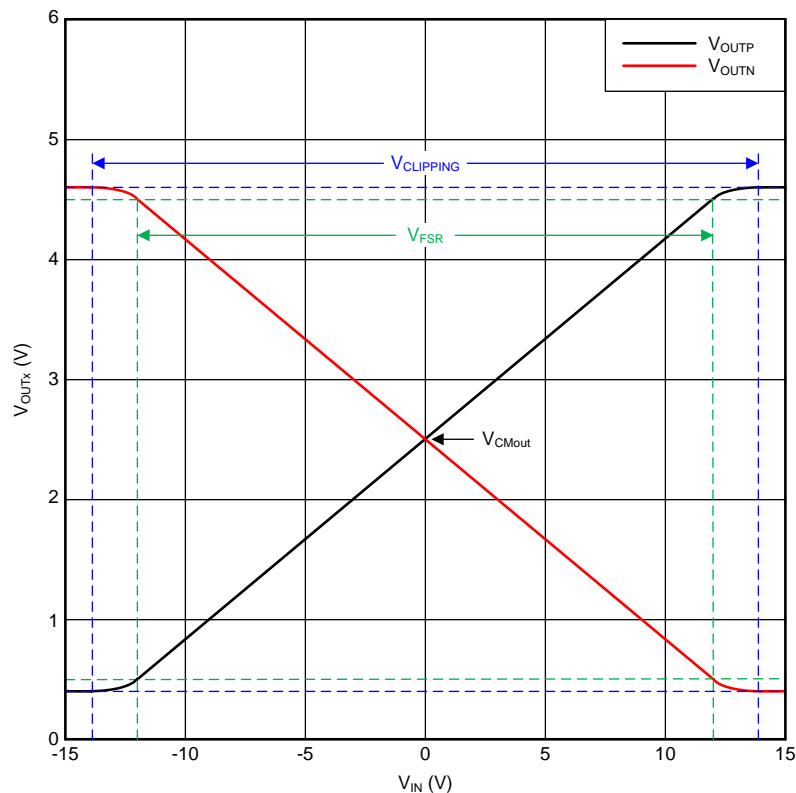
As illustrated in the *Functional Block Diagram*, the ISO224 features an internal clamp protection circuit on the analog input IN. Using external protection circuits is recommended as a secondary protection scheme to protect the device against surges, ESD events, and electrical fast transient (EFT) conditions.

图 42 shows a typical current versus voltage characteristic curve for the input clamp. Limit either the voltage  $V_{IN}$  at the input pin IN to the voltage range as defined in the *Recommended Operating Conditions* table or the input current to the limits as defined in the *Absolute Maximum Ratings* table.



图 42. I-V Curve of the Input Clamp Protection Circuit

图 43 shows a simple method to limit the input current with an external series resistor that is also used as part of the input low-pass filter.

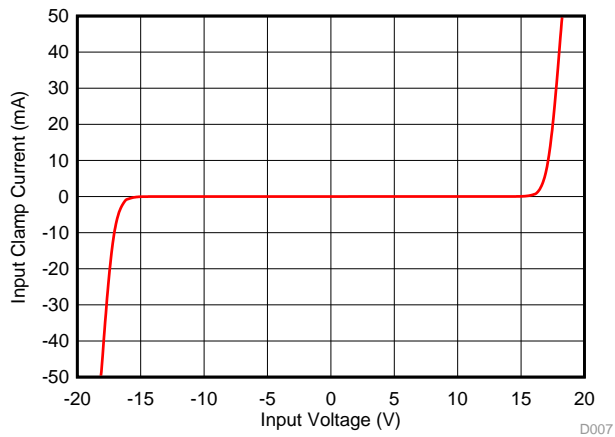

图 43. Series Resistor-Based Input Current Limitation on the Analog Inputs of ISO224

The input overvoltage protection clamp on the ISO224 is intended to control transient excursions on the input pins. Leaving the device in a state such that the clamp circuit is activated for extended periods of time in normal or power-down mode is not recommended because this fault condition can degrade device performance and reliability.

## Feature Description (接下页)

### 8.3.3 Isolation Channel Signal Transmission

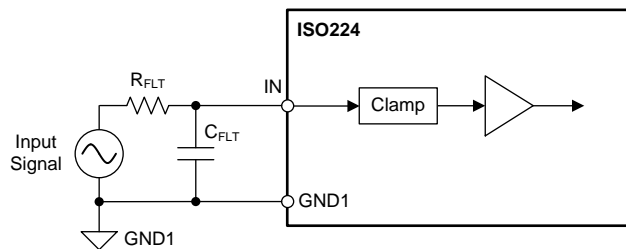
The ISO224 uses an on-off keying (OOK) modulation scheme to transmit the modulator output bitstream across the SiO<sub>2</sub>-based isolation barrier. As shown in 图 44, the transmitter modulates the bitstream at TX IN with an internally-generated, high-frequency carrier across the isolation barrier to represent a digital *one* and does not send a signal to represent the digital *zero*. The nominal frequency of the carrier used inside the ISO224 is 480 MHz.

The receiver demodulates the signal after advanced signal conditioning and produces the output. The ISO224 also incorporates advanced circuit techniques to maximize the CMTI performance and minimize the radiated emissions caused by the high-frequency carrier and IO buffer switching.



图 44. Block Diagram of an Isolation Channel

图 45 shows the concept of the OOK scheme.

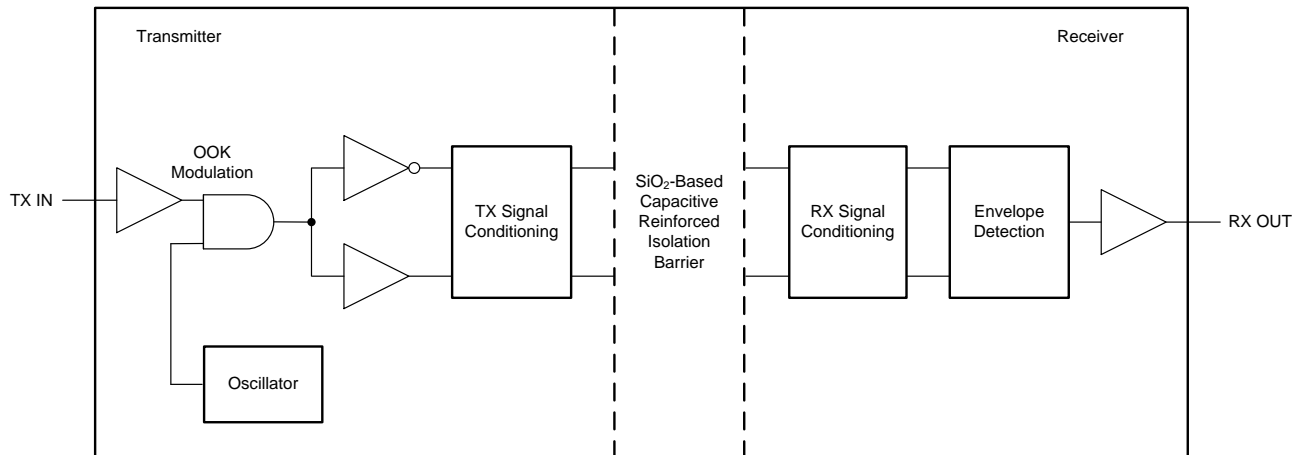

图 45. OOK-Based Modulation Scheme

## Feature Description (接下页)

### 8.3.4 Fail-Safe Output

The ISO224 offers a fail-safe output that simplifies diagnostics on system level. The fail-safe output is active when the high-side power supply VDD1 of the device is missing, independent of the input signal at the IN pin. 图 46 shows that in that case both outputs, OUTP and OUTN, of the device are actively driven close to GND2 (see the  $V_{\text{FAILSAFE}}$  specification in the *Electrical Characteristics* table for details). For easy visualization, an example with the input signal  $V_{\text{IN}} = 0 \text{ V}$  is shown for the valid VDD1 range of 4.5 V to 5.5 V.

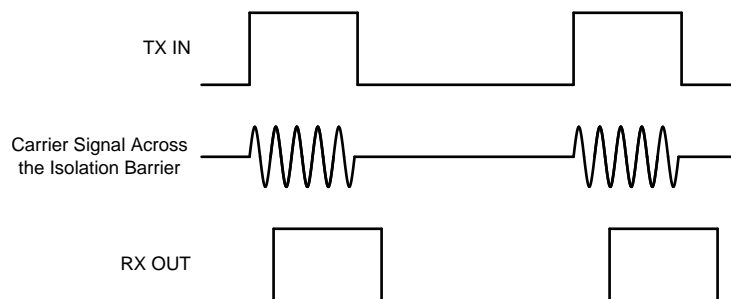

图 46. ISO224 Failsafe Output Behavior With  $V_{\text{IN}} = 0 \text{ V}$

The *ISO224 Fail-Safe Output Feature application report* describes an example of a comparator-based circuit that detects the missing high-side supply in a system.

### 8.4 Device Functional Modes

The ISO224 is operational when the power supplies VDD1 and VDD2 are applied, as specified in the *Recommended Operating Conditions* table.

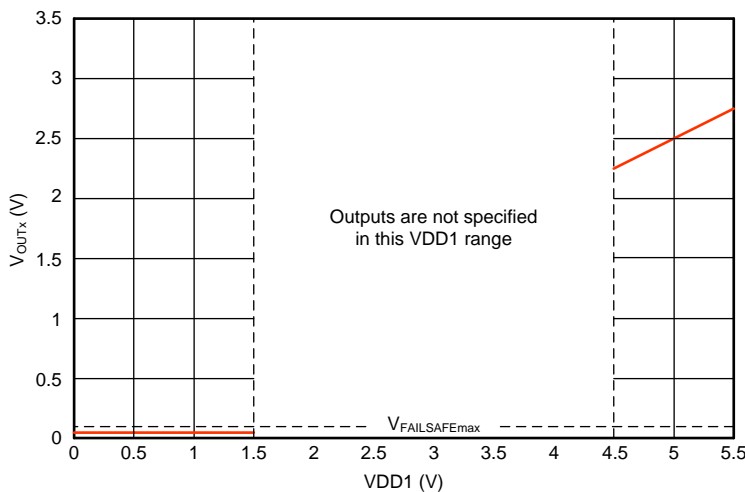
## 9 Application and Implementation

### 注

Information in the following applications sections is not part of the TI component specification, and TI does not warrant its accuracy or completeness. TI's customers are responsible for determining suitability of components for their purposes. Customers should validate and test their design implementation to confirm system functionality.

### 9.1 Application Information

The ISO224 enables high-precision measurement of  $\pm 10$ -V signals that are used in a harsh environment in a wide range of industrial applications. The high input resistance of the device simplifies the connection of its input to different sensors or other signal sources. The very low nonlinearity, AC and DC errors, and temperature drift make the ISO224 a robust, high-performance, isolated amplifier for applications where high voltage isolation is required. The differential output with a full-scale voltage of 4 V offers high immunity to noise and allows connection to a wide range of analog-to-digital converters (ADCs) powered on a 5-V nominal supply.

### 9.2 Typical Application

Isolated amplifiers are often used for data acquisition in industrial applications to safely separate the low-voltage portion of the system from the high common-mode voltage input of the system. The input structure of the ISO224 is optimized for isolated voltage sensing in this kind of application.

图 47 shows a typical operation of the device for voltage sensing as used in power line monitoring systems. The phase voltage amplitude is reduced with a resistive divider to match the input voltage range of the ISO224. The high input voltage range and the high common-mode transient immunity of the device ensure reliable and accurate operation even in high-noise environments.



图 47. Using the ISO224 for AC Voltage Sensing

#### 9.2.1 Design Requirements

表 1 summarizes the typical design requirements for an AC power line voltage sensing application.

表 1. Design Requirements

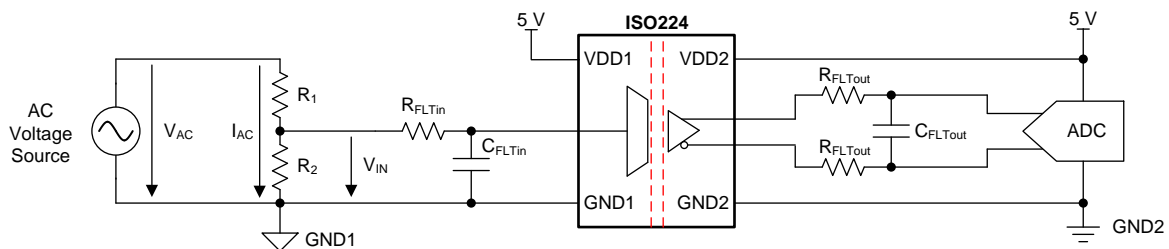
PARAMETER	VALUE
AC voltage range, $V_{AC}$	50 V to 750 V
Bandwidth	600 Hz (minimum)
Current through the resistive divider, $I_{AC}$	1 mA (maximum)

### 9.2.2 Detailed Design Procedure

The high-side power supply (VDD1) for the device is generated with a suitable isolated power source. An example of such a circuit is provided in the [Power Supply Recommendations](#) section.

The floating ground reference (GND1) is derived from one of the ends of the shunt resistor that is connected to the negative input of the device (VINN). If a four-pin shunt is used, the inputs of the device are connected to the inner leads and GND1 is connected to one of the outer shunt leads.

Use Ohm's Law to calculate the minimum total resistance of the resistive divider to limit the cross current  $I_{AC}$  to the desired value:  $R_1 + R_2 = V_{AC} / I_{AC}$ . The input voltage at the ISO224 results from the resistance ratio of  $R_1$  and  $R_2$  and the actual AC voltage:  $V_{IN} = V_{AC} \times R_2 / (R_1 + R_2)$ .

Consider the following two restrictions to choose the proper value of the  $R_1$  and  $R_2$  resistors:

- The voltage drop on  $R_2$  caused by the nominal AC voltage range of the system must not exceed the recommended input voltage range  $V_{IN}$  of the ISO224
- The voltage drop on  $R_2$  caused by the maximum allowed system overvoltage must not exceed the input voltage that causes a clipping output:  $V_{IN} \leq V_{Clipping}$

表 2 lists examples of nominal E96-series (1% accuracy) resistor values for AC systems using 120 V, 240 V, and 400 V as nominal voltages.

表 2. Resistor Value Examples

PARAMETER	120-V <sub>AC</sub> SYSTEM	240-V <sub>AC</sub> SYSTEM	400-V <sub>AC</sub> SYSTEM
Resistive divider resistor $R_1$	115 k $\Omega$	237 k $\Omega$	392 k $\Omega$
Resistive divider resistor $R_2$	12.7 k $\Omega$	12.4 k $\Omega$	12.1 k $\Omega$
Resulting current through resistive divider $I_{AC}$	0.93 mA	0.93 mA	0.98 mA
Resulting input voltage $V_{IN}$	$\pm 11.934$ V	$\pm 11.933$ V	$\pm 11.977$ V

For systems using single-ended input ADCs with a 5-V supply, 图 48 shows an example of a TLV6001-based signal conversion and filter circuit. Tailor the bandwidth of this filter stage to the bandwidth requirement of the system and use NP0-type capacitors for best performance.



图 48. Connecting the ISO224 Output to a Single-Ended Input 5-V ADC

For systems using single-ended,  $\pm 10$ -V input ADCs, the ISO224EVM offers a signal path based on an OPA277 that converts the differential output of the ISO224 and limits the signal bandwidth to 50 kHz.

For more information on the general procedure to design the filtering and driving stages of SAR ADCs, consult the [18-Bit, 1MSPS Data Acquisition Block \(DAQ\) Optimized for Lowest Distortion and Noise](#) and [18-Bit Data Acquisition Block \(DAQ\) Optimized for Lowest Power](#) TI Precision Designs, available for download at [www.ti.com](http://www.ti.com).

### 9.2.3 Application Curves

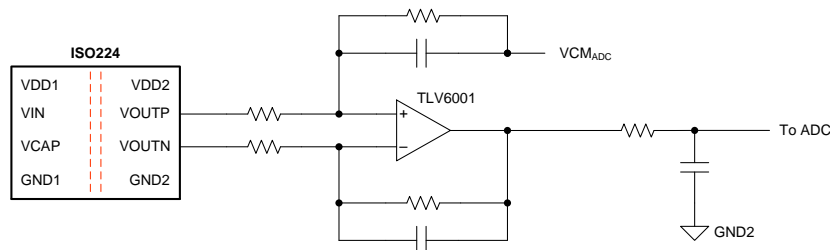
In some applications the system must be protected in case of an overvoltage condition. To allow for fast powering off of the system, a low delay caused by the isolated amplifier is required. 图 49 shows the typical full-scale step response of the device. Consider the delay of the required window comparator and the MCU to calculate the overall response time of the system.



图 49. Step Response of the ISO224

图 50 shows the typical AC response of the device with a full-scale sine wave with a frequency of 20 kHz applied at the input.

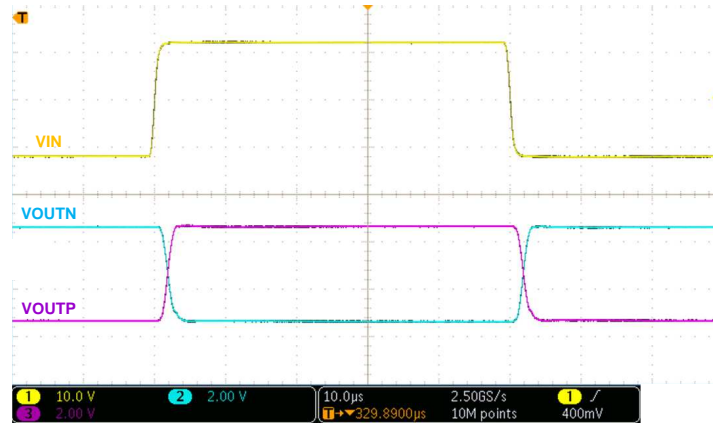

图 50. AC Response of the ISO224 at  $f_{IN} = 20 \text{ kHz}$

### 9.3 What to Do and What Not to Do

Do not leave the input of the ISO224 unconnected (floating) when the device is powered up. If the device input is left floating, both outputs are at the common-mode output voltage level  $V_{CMout}$  as specified in the [Switching Characteristics](#) table. See the [ISO224 Fail-Safe Output Feature application report](#) for more details.

## 10 Power Supply Recommendations

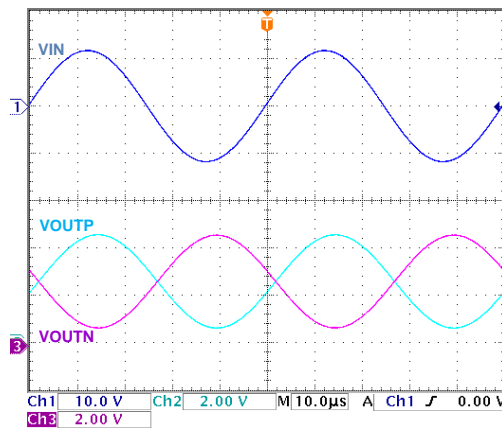
In a typical application, the high-side power supply (VDD1) for the ISO224 is generated from the low-side supply (VDD2) of the device by an isolated DC/DC converter circuit. A low-cost solution is based on the push-pull driver SN6501 and a transformer that supports the desired isolation voltage ratings. TI recommends using a low-ESR decoupling capacitor of 0.1  $\mu\text{F}$  and an additional capacitor of a minimum 1  $\mu\text{F}$  for both supplies of the ISO224. [Figure 51](#) shows the recommended placement of these decoupling capacitors as close as possible to the ISO224 power-supply pins to minimize supply current loops and electromagnetic emissions.

To decouple the output of the integrated LDO, use a 0.22- $\mu\text{F}$  capacitor placed as close to the VCAP pin of the ISO224 as possible.

The ISO224 does not require any specific power up sequencing. Consider the analog settling time  $t_{AS}$  as specified in the [Switching Characteristics](#) table after ramp up of the VDD1 high-side supply.



图 51. SN6501-Based, High-Side Power Supply

## 11 Layout

### 11.1 Layout Guidelines

For best performance, place the 0.22- $\mu$ F capacitor (C7, as shown in [图 52](#)) required for decoupling of the internal LDO output as close as possible to the ISO224 VCAP pin. The 0.1- $\mu$ F ceramic decoupling capacitors for both power supplies (C8 and C9) are located as close as possible to the corresponding VDDx pins followed by the additional 1- $\mu$ F ceramic capacitors for lower-frequency decoupling (C3 and C12). The resistor and capacitor used for the analog input (R1 and C2) are placed next to the decoupling capacitors. For best performance, use 0603-size or 1206-size, SMD-type, ceramic capacitors with low ESR. Connect the supply voltage sources in a way that allows the supply current to flow through the pads of the decoupling capacitors before powering the device.

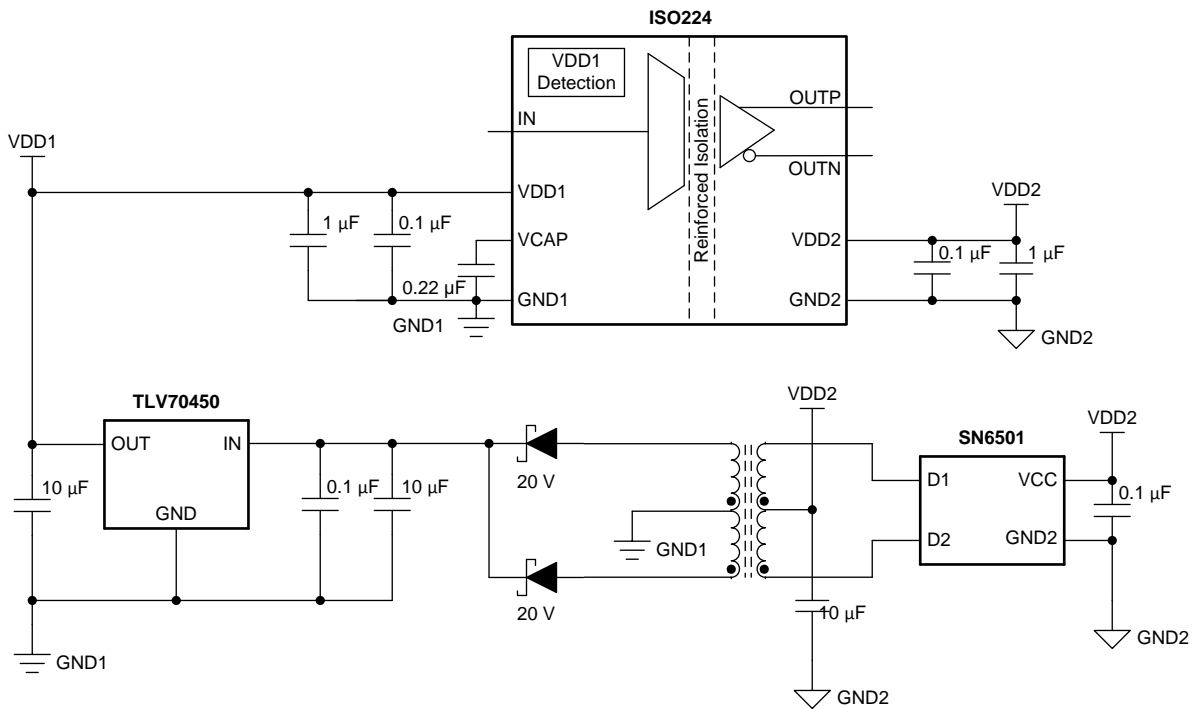
[图 52](#) shows this approach as implemented on the ISO224EVM. Capacitors C3 and C8 decouple the high-side supply VDD1 and capacitors C9 and C12 are used to support the low-side supply VDD2 of the ISO224.

### 11.2 Layout Example

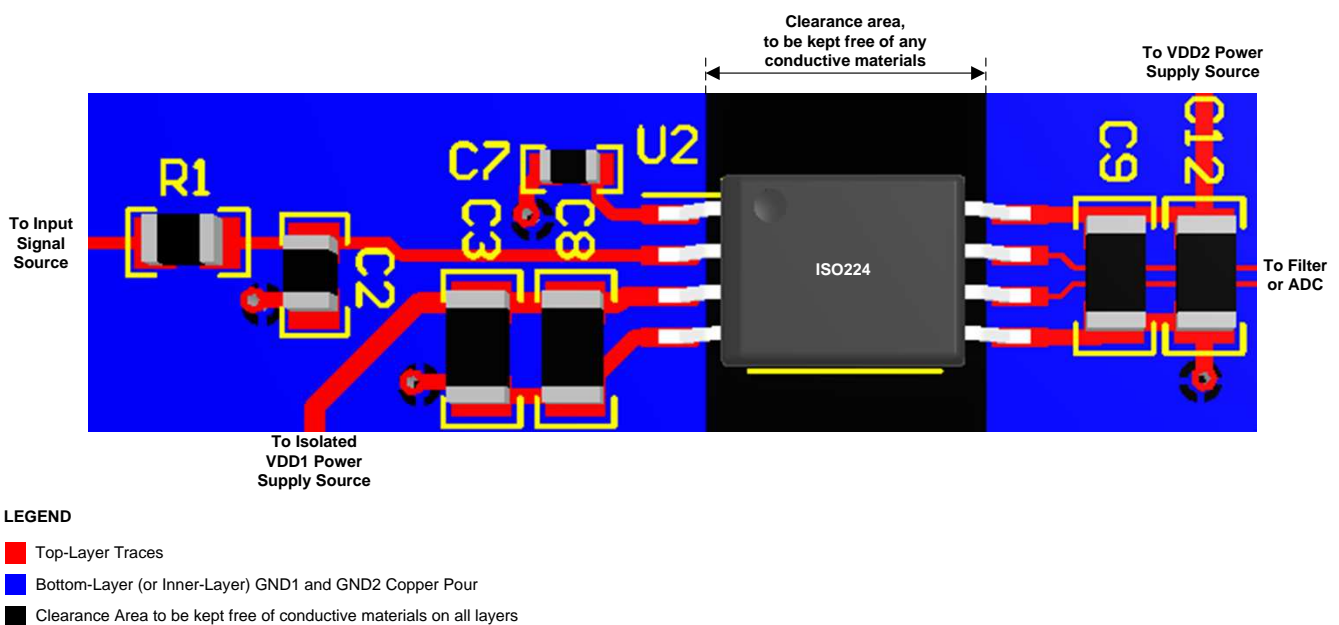

**图 52. Recommended Layout of the ISO224**

## 12 器件和文档支持

### 12.1 文档支持

#### 12.1.1 相关文档

请参阅如下相关文档:

- 德州仪器 (TI), 《隔离相关术语》应用报告
- 德州仪器 (TI), 《ADS794x 14 位、2MSPS、双通道、差分/单端、超低功耗模数转换器》数据表
- 德州仪器 (TI), 《半导体和 IC 封装热指标》应用报告
- 德州仪器 (TI), 《ISO72x 数字隔离器磁场抗扰度》应用报告
- 德州仪器 (TI), 《ISO224 失效防护输出功能》应用报告
- 德州仪器 (TI), 《适用于成本敏感型系统的 TLV600x 低功耗、轨至轨输入/输出、1MHz 运算放大器》数据表
- 德州仪器 (TI), 《OPAx277 高精度运算放大器》数据表
- 德州仪器 (TI), 《经优化可实现最低失真和噪声的 18 位、1MSPS 数据采集块 (DAQ)》TI 设计
- 德州仪器 (TI), 《经优化可实现最低功耗的 18 位数据采集块 (DAQ)》TI 设计
- 德州仪器 (TI), 《SN6501 用于隔离式电源的变压器驱动器》数据表
- 德州仪器 (TI), 《TLV704 24V 输入电压、150mA 超低 I<sub>Q</sub> 低压降稳压器》数据表
- 德州仪器 (TI), 《ISO224EVM 评估模块》用户指南

### 12.2 接收文档更新通知

要接收文档更新通知, 请导航至 [TI.com.cn](http://TI.com.cn) 上的器件产品文件夹。单击右上角的通知我进行注册, 即可每周接收产品信息更改摘要。有关更改的详细信息, 请查看任何已修订文档中包含的修订历史记录。

### 12.3 社区资源

下列链接提供到 TI 社区资源的连接。链接的内容由各个分销商“按照原样”提供。这些内容并不构成 TI 技术规范, 并且不一定反映 TI 的观点; 请参阅 TI 的《使用条款》。

**TI E2E™ 在线社区** TI 的工程师对工程师 (E2E) 社区。此社区的创建目的在于促进工程师之间的协作。在 [e2e.ti.com](http://e2e.ti.com) 中, 您可以咨询问题、分享知识、拓展思路并与同行工程师一道帮助解决问题。

**设计支持** TI 参考设计支持 可帮助您快速查找有帮助的 E2E 论坛、设计支持工具以及技术支持的联系信息。

### 12.4 商标

E2E is a trademark of Texas Instruments.  
All other trademarks are the property of their respective owners.

### 12.5 静电放电警告



这些装置包含有限的内置 ESD 保护。存储或装卸时, 应将导线一起截短或将装置放置于导电泡棉中, 以防止 MOS 门极遭受静电损伤。

### 12.6 术语表

**SLYZ022** — TI 术语表。

这份术语表列出并解释术语、缩写和定义。

### 13 机械、封装和可订购信息

以下页面包含机械、封装和可订购信息。这些信息是指定器件的最新可用数据。数据如有变更，恕不另行通知，且不会对此文档进行修订。如需获取此数据表的浏览器版本，请查阅左侧的导航栏。

**PACKAGING INFORMATION**

Orderable Device	Status (1)	Package Type	Package Drawing	Pins	Package Qty	Eco Plan (2)	Lead finish/ Ball material (6)	MSL Peak Temp (3)	Op Temp (°C)	Device Marking (4/5)	Samples
ISO224ADWV	ACTIVE	SOIC	DWV	8	64	RoHS & Green	NIPDAU	Level-3-260C-168 HR	-55 to 125	ISO224A	<a href="#">Samples</a>
ISO224ADWVR	ACTIVE	SOIC	DWV	8	1000	RoHS & Green	NIPDAU	Level-3-260C-168 HR	-55 to 125	ISO224A	<a href="#">Samples</a>
ISO224BDWV	ACTIVE	SOIC	DWV	8	64	RoHS & Green	NIPDAU	Level-3-260C-168 HR	-55 to 125	ISO224B	<a href="#">Samples</a>
ISO224BDWVR	ACTIVE	SOIC	DWV	8	1000	RoHS & Green	NIPDAU	Level-3-260C-168 HR	-55 to 125	ISO224B	<a href="#">Samples</a>

(1) The marketing status values are defined as follows:

**ACTIVE:** Product device recommended for new designs.

**LIFEBUY:** TI has announced that the device will be discontinued, and a lifetime-buy period is in effect.

**NRND:** Not recommended for new designs. Device is in production to support existing customers, but TI does not recommend using this part in a new design.

**PREVIEW:** Device has been announced but is not in production. Samples may or may not be available.

**OBSOLETE:** TI has discontinued the production of the device.

(2) **RoHS:** TI defines "RoHS" to mean semiconductor products that are compliant with the current EU RoHS requirements for all 10 RoHS substances, including the requirement that RoHS substance do not exceed 0.1% by weight in homogeneous materials. Where designed to be soldered at high temperatures, "RoHS" products are suitable for use in specified lead-free processes. TI may reference these types of products as "Pb-Free".

**RoHS Exempt:** TI defines "RoHS Exempt" to mean products that contain lead but are compliant with EU RoHS pursuant to a specific EU RoHS exemption.

**Green:** TI defines "Green" to mean the content of Chlorine (Cl) and Bromine (Br) based flame retardants meet JS709B low halogen requirements of <=1000ppm threshold. Antimony trioxide based flame retardants must also meet the <=1000ppm threshold requirement.

(3) MSL, Peak Temp. - The Moisture Sensitivity Level rating according to the JEDEC industry standard classifications, and peak solder temperature.

(4) There may be additional marking, which relates to the logo, the lot trace code information, or the environmental category on the device.

(5) Multiple Device Markings will be inside parentheses. Only one Device Marking contained in parentheses and separated by a "-" will appear on a device. If a line is indented then it is a continuation of the previous line and the two combined represent the entire Device Marking for that device.

(6) Lead finish/Ball material - Orderable Devices may have multiple material finish options. Finish options are separated by a vertical ruled line. Lead finish/Ball material values may wrap to two lines if the finish value exceeds the maximum column width.

**Important Information and Disclaimer:**The information provided on this page represents TI's knowledge and belief as of the date that it is provided. TI bases its knowledge and belief on information provided by third parties, and makes no representation or warranty as to the accuracy of such information. Efforts are underway to better integrate information from third parties. TI has taken and

continues to take reasonable steps to provide representative and accurate information but may not have conducted destructive testing or chemical analysis on incoming materials and chemicals. TI and TI suppliers consider certain information to be proprietary, and thus CAS numbers and other limited information may not be available for release.

In no event shall TI's liability arising out of such information exceed the total purchase price of the TI part(s) at issue in this document sold by TI to Customer on an annual basis.

**TAPE AND REEL INFORMATION**

**QUADRANT ASSIGNMENTS FOR PIN 1 ORIENTATION IN TAPE**



\*All dimensions are nominal

Device	Package Type	Package Drawing	Pins	SPQ	Reel Diameter (mm)	Reel Width W1 (mm)	A0 (mm)	B0 (mm)	K0 (mm)	P1 (mm)	W (mm)	Pin1 Quadrant
ISO224ADWVR	SOIC	DWV	8	1000	330.0	16.4	12.05	6.15	3.3	16.0	16.0	Q1
ISO224BDWVR	SOIC	DWV	8	1000	330.0	16.4	12.05	6.15	3.3	16.0	16.0	Q1

**TAPE AND REEL BOX DIMENSIONS**

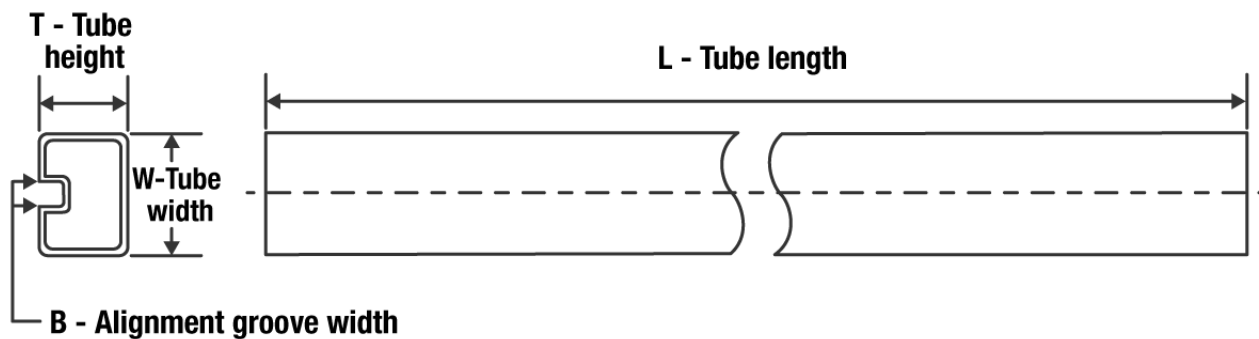

\*All dimensions are nominal

Device	Package Type	Package Drawing	Pins	SPQ	Length (mm)	Width (mm)	Height (mm)
ISO224ADWVR	SOIC	DWV	8	1000	350.0	350.0	43.0
ISO224BDWVR	SOIC	DWV	8	1000	350.0	350.0	43.0

**TUBE**

\*All dimensions are nominal

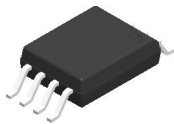
Device	Package Name	Package Type	Pins	SPQ	L (mm)	W (mm)	T (μm)	B (mm)
ISO224ADWV	DWV	SOIC	8	64	505.46	13.94	4826	6.6
ISO224BDWV	DWV	SOIC	8	64	505.46	13.94	4826	6.6



DWV0008A

SOIC - 2.8 mm max height

SOIC

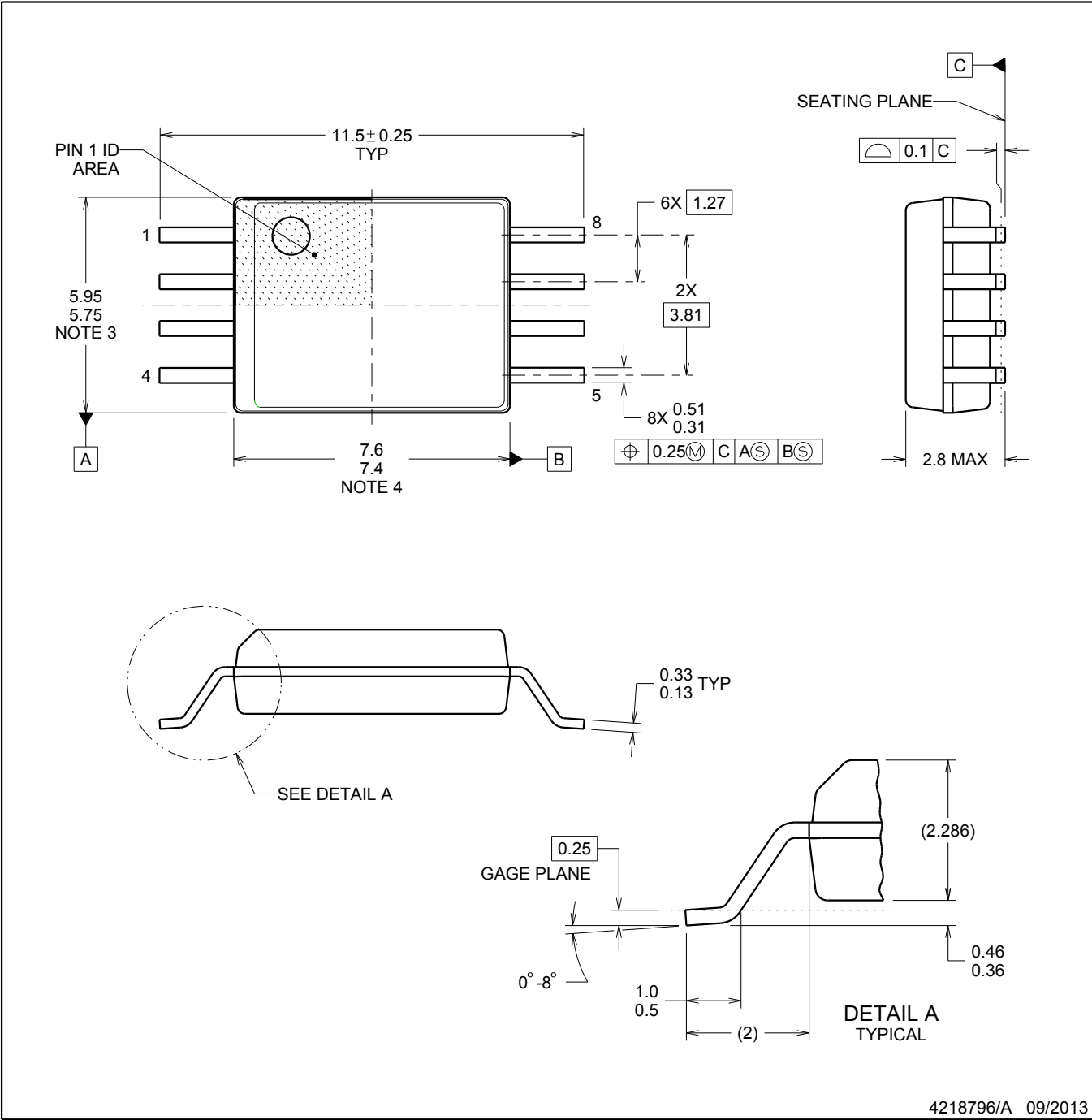

NOTES:

- 1. All linear dimensions are in millimeters. Dimensions in parenthesis are for reference only. Dimensioning and tolerancing per ASME Y14.5M.
- 2. This drawing is subject to change without notice.
- 3. This dimension does not include mold flash, protrusions, or gate burrs. Mold flash, protrusions, or gate burrs shall not exceed 0.15 mm, per side.
- 4. This dimension does not include interlead flash. Interlead flash shall not exceed 0.25 mm, per side.

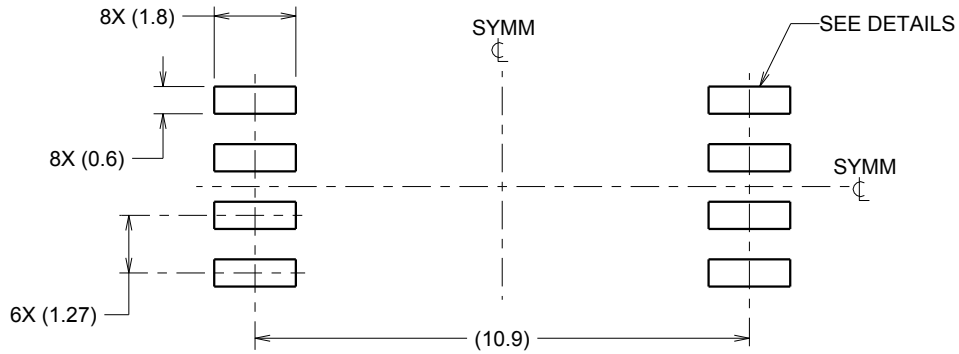

LAND PATTERN EXAMPLE  
 9.1 mm NOMINAL CLEARANCE/CREEPAGE  
 SCALE:6X

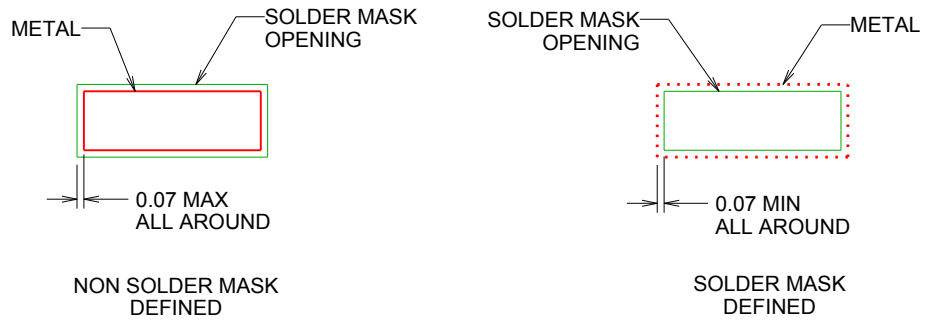

SOLDER MASK DETAILS

4218796/A 09/2013

NOTES: (continued)

- 5. Publication IPC-7351 may have alternate designs.
- 6. Solder mask tolerances between and around signal pads can vary based on board fabrication site.

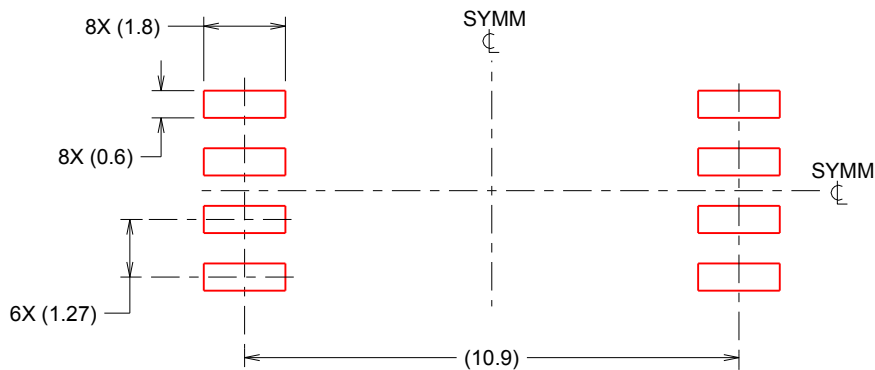

SOLDER PASTE EXAMPLE  
 BASED ON 0.125 mm THICK STENCIL  
 SCALE:6X

4218796/A 09/2013

NOTES: (continued)

- 7. Laser cutting apertures with trapezoidal walls and rounded corners may offer better paste release. IPC-7525 may have alternate design recommendations.
- 8. Board assembly site may have different recommendations for stencil design.

## 重要声明和免责声明

TI“按原样”提供技术和可靠性数据（包括数据表）、设计资源（包括参考设计）、应用或其他设计建议、网络工具、安全信息和其他资源，不保证没有瑕疵且不做任何明示或暗示的担保，包括但不限于对适销性、某特定用途方面的适用性或不侵犯任何第三方知识产权的暗示担保。

这些资源可供使用 TI 产品进行设计的熟练开发人员使用。您将自行承担以下全部责任：(1) 针对您的应用选择合适的 TI 产品，(2) 设计、验证并测试您的应用，(3) 确保您的应用满足相应标准以及任何其他功能安全、信息安全、监管或其他要求。

这些资源如有变更，恕不另行通知。TI 授权您仅可将这些资源用于研发本资源所述的 TI 产品的应用。严禁对这些资源进行其他复制或展示。您无权使用任何其他 TI 知识产权或任何第三方知识产权。您应全额赔偿因在这些资源的使用中对 TI 及其代表造成的任何索赔、损害、成本、损失和债务，TI 对此概不负责。

TI 提供的产品受 [TI 的销售条款](#) 或 [ti.com](#) 上其他适用条款/TI 产品随附的其他适用条款的约束。TI 提供这些资源并不会扩展或以其他方式更改 TI 针对 TI 产品发布的适用的担保或担保免责声明。

TI 反对并拒绝您可能提出的任何其他或不同的条款。

邮寄地址：Texas Instruments, Post Office Box 655303, Dallas, Texas 75265

Copyright © 2022，德州仪器 (TI) 公司