



LOW-NOISE, HIGH-SPEED, CURRENT FEEDBACK AMPLIFIERS

Check for Samples: [THS3112](#), [THS3115](#)

FEATURES

- **Low Noise:**
 - 2.9-pA/ $\sqrt{\text{Hz}}$ Noninverting Current Noise
 - 10.8-pA/ $\sqrt{\text{Hz}}$ Inverting Current Noise
 - 2.2-nV/ $\sqrt{\text{Hz}}$ Voltage Noise
- **Wide Supply Voltage Range: $\pm 5\text{ V}$ to $\pm 15\text{ V}$**
- **Wide Output Swing:**
 - 25-V_{PP} Output Voltage, $R_L = 100\ \Omega$, $\pm 15\text{-V}$ Supply
- **High Output Current: 150 mA (Min)**
- **High Speed:**
 - 110-MHz (-3-dB BW , $G = 1$, $\pm 15\text{ V}$)
 - 1550-V/ μs Slew Rate ($G = 2$, $\pm 15\text{ V}$)
- **Low Distortion ($G = 2$):**
 - -78 dBc (1 MHz, 2 V_{PP}, 100- Ω Load)
- **Low-Power Shutdown (THS3115)**
 - 300- μA Shutdown Quiescent Current per Channel
- **Standard SOIC, SOIC PowerPAD™, and TSSOP PowerPAD Packages**
- **Evaluation Module Available**

APPLICATIONS

- **Communication Equipment**
- **Video Distribution**
- **Motor Drivers**
- **Piezo Drivers**

DESCRIPTION

The THS3112/5 are low-noise, high-speed current feedback amplifiers, ideal for any application requiring high output current. The low noninverting current noise of 2.9 pA/ $\sqrt{\text{Hz}}$ and the low inverting current noise of 10.8 pA/ $\sqrt{\text{Hz}}$ increase signal-to-noise ratios for enhanced signal resolution. The THS3112/5 can operate from $\pm 5\text{-V}$ to $\pm 15\text{-V}$ supply voltages, while drawing as little as 4.5 mA of supply current per channel. It offers low -78-dBc total harmonic distortion driving 2 V_{PP} into a 100- Ω load. The THS3115 features a low-power shutdown mode, consuming only 300- μA shutdown quiescent current per channel. The THS3112/5 are packaged in standard SOIC, SOIC PowerPAD™, and TSSOP PowerPAD packages.

VOLTAGE NOISE AND CURRENT NOISE
VS
FREQUENCY

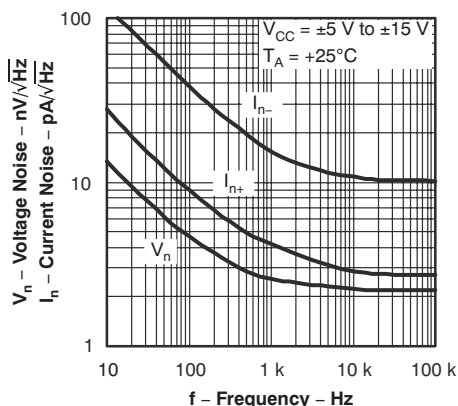

THS3112
SOIC (D) AND
SOIC PowerPAD™ (DDA) PACKAGE
(TOP VIEW)

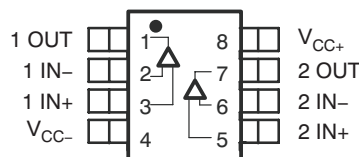

THS3115
SOIC (D) AND
TSSOP PowerPAD™ (PWP) PACKAGE
(TOP VIEW)

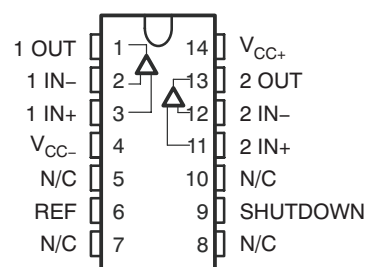

Please be aware that an important notice concerning availability, standard warranty, and use in critical applications of Texas Instruments semiconductor products and disclaimers thereto appears at the end of this data sheet.

PowerPAD is a trademark of Texas Instruments.

All other trademarks are the property of their respective owners.



This integrated circuit can be damaged by ESD. Texas Instruments recommends that all integrated circuits be handled with appropriate precautions. Failure to observe proper handling and installation procedures can cause damage.

ESD damage can range from subtle performance degradation to complete device failure. Precision integrated circuits may be more susceptible to damage because very small parametric changes could cause the device not to meet its published specifications.

AVAILABLE OPTIONS⁽¹⁾

T _A	PACKAGED DEVICE				EVALUATION MODULES
	SOIC-8 (D)	SOIC-8 PowerPAD (DDA)	SOIC-14 (D)	TSSOP-14 (PWP)	
0°C to +70°C	THS3112CD	THS3112CDDA	THS3115CD	THS3115CPWP	THS3112EVM THS3115EVM
40°C to +85°C	THS3112ID	THS3112IDDA	THS3115ID	THS3115IPWP	

(1) For the most current specification and package information, refer to the Package Option Addendum located at the end of this data sheet or see the TI web site at www.ti.com.

ABSOLUTE MAXIMUM RATINGS⁽¹⁾

Over operating free-air temperature (unless otherwise noted).

	UNIT	
Supply voltage, V _{CC+} to V _{CC-}	33 V	
Input voltage	±V _{CC}	
Output current (see ⁽²⁾)	275 mA	
Differential input voltage	±4 V	
Maximum junction temperature	+150°C	
Total power dissipation at (or below) +25°C free-air temperature	See Dissipation Ratings Table	
Operating free-air temperature, T _A	Commercial	0°C to +70°C
	Industrial	–40°C to +85°C
Storage temperature, T _{stg}	Commercial	–65°C to +125°C
	Industrial	–65°C to +125°C

- (1) Stresses beyond those listed under *Absolute Maximum Ratings* may cause permanent damage to the device. These are stress ratings only, and functional operation of the device at these or any other conditions beyond those indicated under *Recommended Operating Conditions* is not implied. Exposure to absolute-maximum-rated conditions for extended periods may affect device reliability.
- (2) The THS3122 and THS3125 may incorporate a PowerPAD™ on the underside of the chip. This pad acts as a heatsink and must be connected to a thermally dissipating plane for proper power dissipation. Failure to do so may result in exceeding the maximum junction temperature which could permanently damage the device. See TI Technical Brief [SLMA002](#) for more information about utilizing the PowerPAD™ thermally-enhanced package.

DISSIPATION RATINGS TABLE

PACKAGE	θ _{JA}	T _A = +25°C POWER RATING
D-8	95°C/W ⁽¹⁾	1.32 W
DDA	67°C/W	1.87 W
D-14	66.6°C/W ⁽¹⁾	1.88 W
PWP	37.5°C/W	3.3 W

(1) These data were taken using the JEDEC proposed high-K test PCB. For the JEDEC low-K test PCB, the θ_{JA} is 168°C/W for the D-8 package and 122.3°C/W for the D-14 package.

RECOMMENDED OPERATING CONDITIONS

		MIN	NOM	MAX	UNIT
Supply voltage, V_{CC+} to V_{CC-}	Dual supply	± 5		± 15	V
	Single supply	10		30	
Operating free-air temperature, T_A	C-suffix	0		+70	°C
	I-suffix	-40		+85	

ELECTRICAL CHARACTERISTICS

Over operating free-air temperature range, $T_A = +25^\circ\text{C}$, $V_{CC} = \pm 15\text{ V}$, $R_F = 750\ \Omega$, and $R_L = 100\ \Omega$ (unless otherwise noted).

DYNAMIC PERFORMANCE								
PARAMETER		TEST CONDITIONS			MIN	TYP	MAX	UNIT
BW	Small-signal bandwidth (-3 dB)	$R_L = 100\ \Omega$	$R_F = 1\ \text{k}\Omega$, $G = 1$	$V_{CC} = \pm 5\text{ V}$		95	MHz	
				$V_{CC} = \pm 15\text{ V}$		110		
	$R_L = 100\ \Omega$	$R_F = 750\ \Omega$, $G = 2$	$V_{CC} = \pm 5\text{ V}$		103			
			$V_{CC} = \pm 15\text{ V}$		110			
Bandwidth (0.1 dB)	$R_F = 750\ \Omega$, $G = 2$	$V_{CC} = \pm 5\text{ V}$		25				
		$V_{CC} = \pm 15\text{ V}$		48				
SR	Slew rate ⁽¹⁾ , $G = 8$	$G = 2$, $R_F = 680\ \Omega$	$V_O = 10\ V_{PP}$	$V_{CC} = \pm 15\text{ V}$		1550	V/ μs	
			$V_O = 5\ V_{PP}$	$V_{CC} = \pm 5\text{ V}$		820		
				$V_{CC} = \pm 15\text{ V}$		1300		
t_s	Settling time to 0.1%	$G = -1$	$V_O = 2\ V_{PP}$	$V_{CC} = \pm 5\text{ V}$		50	ns	
			$V_O = 5\ V_{PP}$	$V_{CC} = \pm 15\text{ V}$		63		

(1) Slew rate is defined from the 25% to the 75% output levels.

NOISE/DISTORTION PERFORMANCE								
PARAMETER		TEST CONDITIONS			MIN	TYP	MAX	UNIT
THD	Total harmonic distortion	$G = 2$, $R_F = 680\ \Omega$, $V_{CC} = \pm 15\text{ V}$, $f = 1\ \text{MHz}$	$V_{O(PP)} = 2\text{ V}$		-78		dBc	
			$V_{O(PP)} = 8\text{ V}$		-75			
		$G = 2$, $R_F = 680\ \Omega$, $V_{CC} = \pm 5\text{ V}$, $f = 1\ \text{MHz}$	$V_{O(PP)} = 2\text{ V}$		-76			
			$V_{O(PP)} = 6\text{ V}$		-74			
V_n	Input voltage noise	$V_{CC} = \pm 5\text{ V}, \pm 15\text{ V}$	$f = 10\ \text{kHz}$		2.2		nV/ $\sqrt{\text{Hz}}$	
I_n	Input current noise	Noninverting Input	$V_{CC} = \pm 5\text{ V}, \pm 15\text{ V}$	$f = 10\ \text{kHz}$	2.9		pA/ $\sqrt{\text{Hz}}$	
		Inverting Input			10.8			
Crosstalk		$G = 2$, $f = 1\ \text{MHz}$, $V_O = 2\ V_{PP}$	$V_{CC} = \pm 5\text{ V}$		-67		dBc	
			$V_{CC} = \pm 15\text{ V}$		-67			
Differential gain error		$G = 2$, $R_L = 150\ \Omega$ 40 IRE modulation	$V_{CC} = \pm 5\text{ V}$		0.01		%	
			$V_{CC} = \pm 15\text{ V}$		0.01			
Differential phase error		$\pm 100\ \text{IRE Ramp}$ NTSC and PAL	$V_{CC} = \pm 5\text{ V}$		0.011		degrees	
			$V_{CC} = \pm 15\text{ V}$		0.011			

ELECTRICAL CHARACTERISTICS (continued)

Over operating free-air temperature range, $T_A = +25^\circ\text{C}$, $V_{CC} = \pm 15\text{ V}$, $R_F = 750\ \Omega$, and $R_L = 100\ \Omega$ (unless otherwise noted).

DC PERFORMANCE								
PARAMETER		TEST CONDITIONS			MIN	TYP	MAX	UNIT
V_{IO}	Input offset voltage	$V_{CC} = \pm 5\text{ V}, V_{CC} = \pm 15\text{ V}$	$T_A = +25^\circ\text{C}$		6	10	mV	
			$T_A = \text{full range}$			13		
	Channel offset voltage matching		$T_A = +25^\circ\text{C}$		1	3		
			$T_A = \text{full range}$			4		
	Offset drift		$T_A = \text{full range}$		10		$\mu\text{V}/^\circ\text{C}$	
I_{IB}	IN- Input bias current	$V_{CC} = \pm 5\text{ V}, V_{CC} = \pm 15\text{ V}$	$T_A = +25^\circ\text{C}$			23	μA	
			$T_A = \text{full range}$			30		
	IN+ Input bias current		$T_A = +25^\circ\text{C}$		0.33	2		
			$T_A = \text{full range}$			3		
I_{IO}	Input offset current	$V_{CC} = \pm 5\text{ V}, V_{CC} = \pm 15\text{ V}$	$T_A = +25^\circ\text{C}$		4	22	μA	
			$T_A = \text{full range}$			30		
Z_{OL}	Open-loop transimpedance	$V_{CC} = \pm 5\text{ V}, V_{CC} = \pm 15\text{ V}$	$R_L = 1\text{ k}\Omega$		1		M Ω	

INPUT CHARACTERISTICS								
PARAMETER		TEST CONDITIONS			MIN	TYP	MAX	UNIT
V_{ICR}	Input common-mode voltage range	$V_{CC} = \pm 5\text{ V}$	$T_A = \text{full range}$		± 2.5	± 2.7	V	
		$V_{CC} = \pm 15\text{ V}$			± 12.5	± 12.7		
CMRR	Common-mode rejection ratio	$V_{CC} = \pm 5\text{ V}, V_I = -2.5\text{ V to } 2.5\text{ V}$	$T_A = +25^\circ\text{C}$		56	62	dB	
			$T_A = \text{full range}$		54			
		$V_{CC} = \pm 15\text{ V}, V_I = -12.5\text{ V to } 12.5\text{ V}$	$T_A = +25^\circ\text{C}$		63	67		
			$T_A = \text{full range}$		60			
R_I	Input resistance	IN+			1.5		M Ω	
		IN-			15		Ω	
C_I	Input capacitance				2		pF	

OUTPUT CHARACTERISTICS								
PARAMETER		TEST CONDITIONS			MIN	TYP	MAX	UNIT
V_O	Output voltage swing	$G = 4, V_I = 1\text{ V}, V_{CC} = \pm 5\text{ V},$	$R_L = 1\text{ k}\Omega$	$T_A = +25^\circ\text{C}$		3.9	V	
			$R_L = 100\ \Omega$	$T_A = +25^\circ\text{C}$		3.6		3.8
				$T_A = \text{full range}$		3.4		
		$G = 4, V_I = 3.4\text{ V}, V_{CC} = \pm 15\text{ V},$	$R_L = 1\text{ k}\Omega$	$T_A = +25^\circ\text{C}$		13.5	V	
			$R_L = 100\ \Omega$	$T_A = +25^\circ\text{C}$		12.2		13.3
				$T_A = \text{full range}$		12		
I_O	Output current drive	$G = 4, V_I = 0.9\text{ V}, V_{CC} = \pm 5\text{ V},$	$R_L = 25\ \Omega$	$T_A = +25^\circ\text{C}$	100	130	mA	
		$G = 4, V_I = 1.7\text{ V}, V_{CC} = \pm 15\text{ V},$	$R_L = 25\ \Omega$	$T_A = +25^\circ\text{C}$	175	270	mA	
r_o	Output resistance	Open loop			14		Ω	

ELECTRICAL CHARACTERISTICS (continued)

Over operating free-air temperature range, $T_A = +25^\circ\text{C}$, $V_{CC} = \pm 15\text{ V}$, $R_F = 750\ \Omega$, and $R_L = 100\ \Omega$ (unless otherwise noted).

POWER SUPPLY							
PARAMETER		TEST CONDITIONS		MIN	TYP	MAX	UNIT
I_{CC}	Quiescent current (per channel)	$V_{CC} = \pm 5\text{ V}$	$T_A = +25^\circ\text{C}$		4.4	5.5	mA
			$T_A = \text{full range}$			6	
		$V_{CC} = \pm 15\text{ V}$	$T_A = +25^\circ\text{C}$		4.9	6.5	
			$T_A = \text{full range}$			7.5	
PSRR	Power-supply rejection ratio	$V_{CC} = \pm 5\text{ V}$	$T_A = +25^\circ\text{C}$	53	60	dB	
			$T_A = \text{full range}$	50			
		$V_{CC} = \pm 15\text{ V}$	$T_A = +25^\circ\text{C}$	60	69		
			$T_A = \text{full range}$	55			

SHUTDOWN CHARACTERISTICS (THS3115 Only)							
PARAMETER		TEST CONDITIONS		MIN	TYP	MAX	UNIT
V_{REF}	REF pin voltage level			V_{CC-}		$V_{CC+} - 4$	V
V_{SHDN}	SHUTDOWN pin voltage level	Enable				REF + 0.8	V
		Disable		REF + 2			V
$I_{CC(SHDN)}$	Shutdown quiescent current (per channel)	REF = 0 V, $V_{CC} = \pm 5\text{ V}$ to $\pm 15\text{ V}$			0.3	0.45	mA
t_{DIS}	Disable time ⁽¹⁾	$V_{CC} = \pm 15\text{ V}$			200		ns
t_{EN}	Enable time ⁽¹⁾	$V_{CC} = \pm 15\text{ V}$			300		ns
$I_{IL(SHDN)}$	Shutdown pin low level leakage current	$V_{CC} = \pm 5\text{ V}$ to $\pm 15\text{ V}$, $V_{SHDN} = 0\text{ V}$, REF = 0 V			18	25	μA
$I_{IH(SHDN)}$	Shutdown pin high level leakage current	$V_{CC} = \pm 5\text{ V}$ to $\pm 15\text{ V}$, $V_{SHDN} = 3.3\text{ V}$, REF = 0 V			110	130	μA

(1) Disable/enable time is defined as the time from when the shutdown signal is applied to the SHDN pin to when the supply current has reached half of its final value.

TYPICAL CHARACTERISTICS

TABLE OF GRAPHS

			FIGURE
Small-signal closed-loop gain	vs Frequency		Figure 1 to Figure 11, Figure 13, Figure 14
Gain and phase	vs Frequency		Figure 12
Small-signal closed-loop noninverting gain	vs Frequency		Figure 15, Figure 16
Small-signal closed-loop inverting gain	vs Frequency		Figure 17, Figure 18
Small- and large-signal output	vs Frequency		Figure 19, Figure 20
Harmonic distortion	vs Frequency		Figure 20, Figure 21
	vs Peak-to-peak output voltage		Figure 23, Figure 24
V_n, I_n	Voltage noise and current noise	vs Frequency	Figure 25
CMRR	Common-mode rejection ratio	vs Frequency	Figure 26
PSRR	Power-supply rejection ratio	vs Frequency	Figure 27
	Crosstalk	vs Frequency	Figure 28
z_o	Output impedance	vs Frequency	Figure 29
SR	Slew rate	vs Output voltage step	Figure 30
V_{IO}	Input offset voltage	vs Free-air temperature	Figure 31
		vs Common-mode input voltage	Figure 32
I_B	Input bias current	vs Free-air temperature	Figure 33
V_O	Output voltage	vs Output current	Figure 34, Figure 35
	Output voltage headroom	vs Output current	Figure 36
I_{CC}	Supply current (per channel)	vs Supply voltage	Figure 37
	Shutdown response		Figure 38

TYPICAL CHARACTERISTICS

SMALL-SIGNAL CLOSED-LOOP GAIN vs FREQUENCY

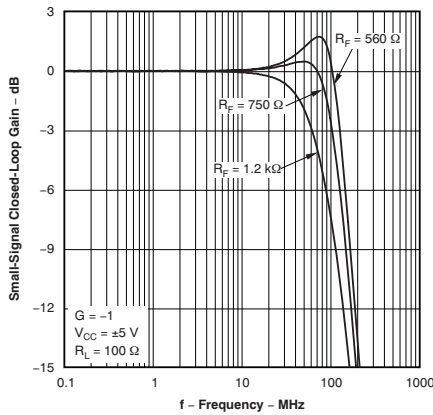

Figure 1.

SMALL-SIGNAL CLOSED-LOOP GAIN vs FREQUENCY

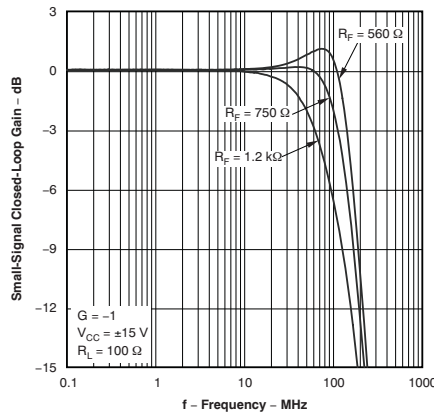

Figure 2.

SMALL-SIGNAL CLOSED-LOOP GAIN vs FREQUENCY

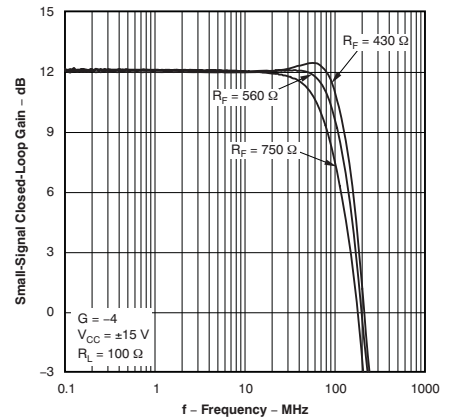

Figure 3.

SMALL-SIGNAL CLOSED-LOOP GAIN vs FREQUENCY

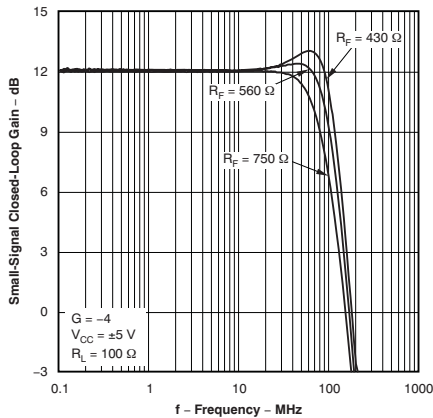

Figure 4.

SMALL-SIGNAL CLOSED-LOOP GAIN vs FREQUENCY

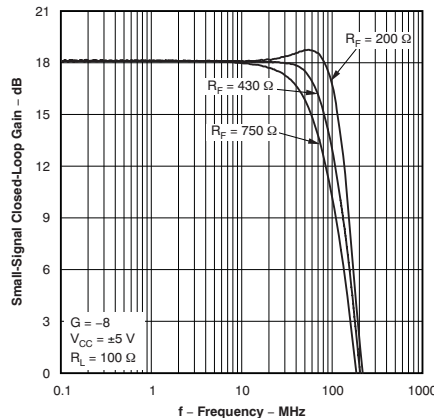

Figure 5.

SMALL-SIGNAL CLOSED-LOOP GAIN vs FREQUENCY

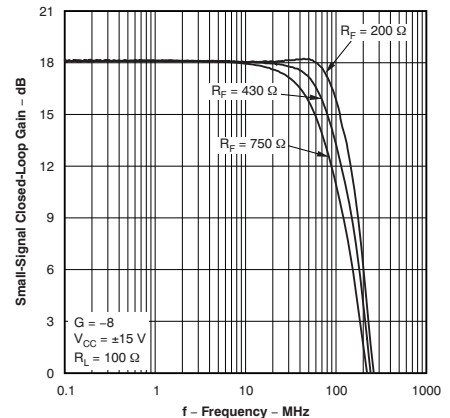

Figure 6.

SMALL-SIGNAL CLOSED-LOOP GAIN vs FREQUENCY

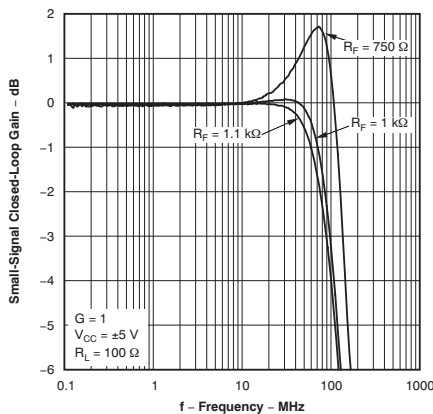

Figure 7.

SMALL-SIGNAL CLOSED-LOOP GAIN vs FREQUENCY

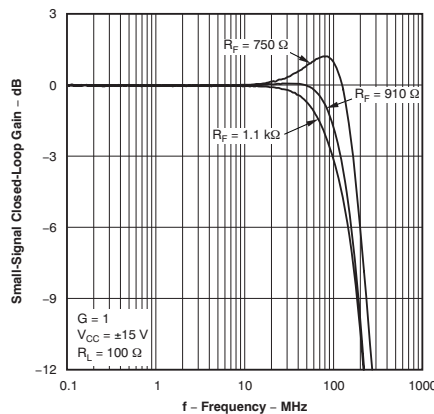

Figure 8.

SMALL-SIGNAL CLOSED-LOOP GAIN vs FREQUENCY

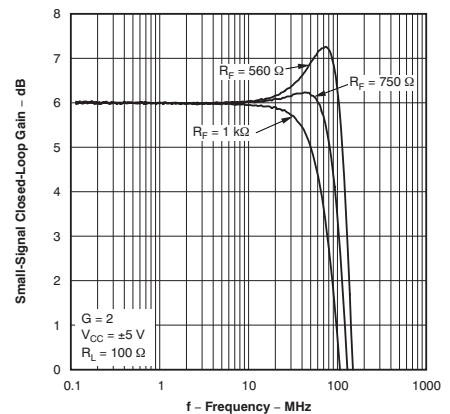

Figure 9.

TYPICAL CHARACTERISTICS (continued)

SMALL-SIGNAL CLOSED-LOOP GAIN vs FREQUENCY

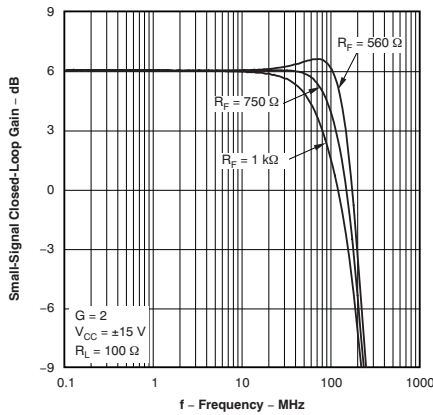

Figure 10.

SMALL-SIGNAL CLOSED-LOOP GAIN vs FREQUENCY

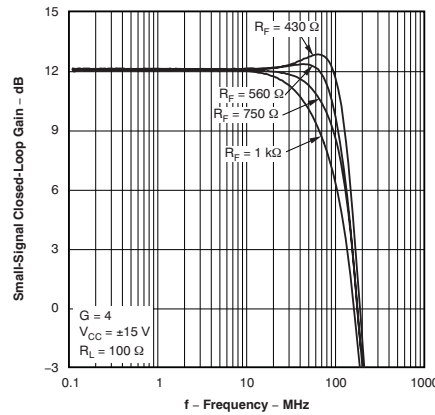

Figure 11.

GAIN AND PHASE vs FREQUENCY

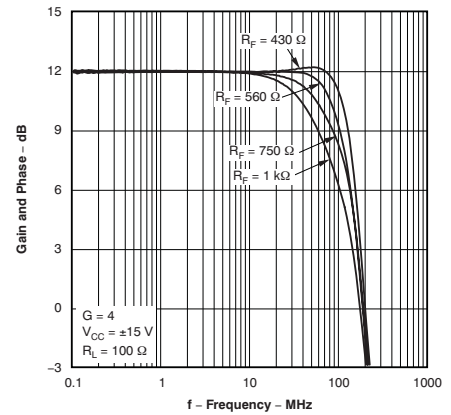

Figure 12.

SMALL-SIGNAL CLOSED-LOOP GAIN vs FREQUENCY

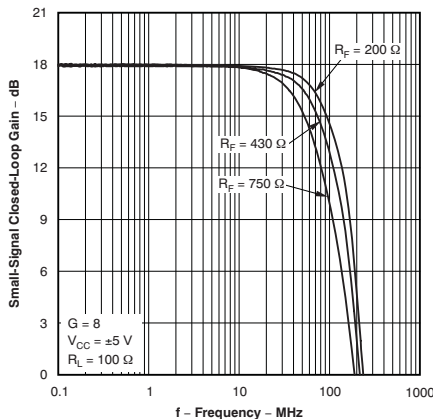

Figure 13.

SMALL-SIGNAL CLOSED-LOOP GAIN vs FREQUENCY

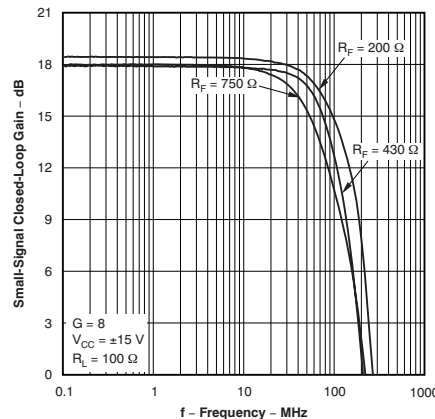

Figure 14.

SMALL-SIGNAL CLOSED-LOOP NONINVERTING GAIN vs FREQUENCY

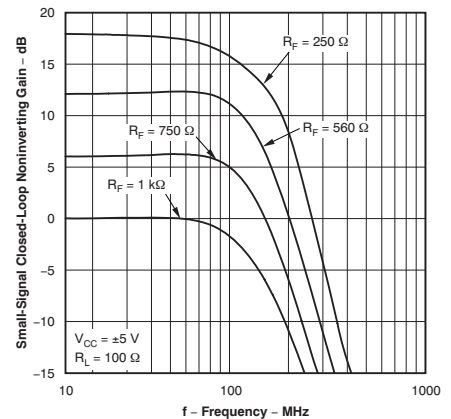

Figure 15.

SMALL-SIGNAL CLOSED-LOOP NONINVERTING GAIN vs FREQUENCY

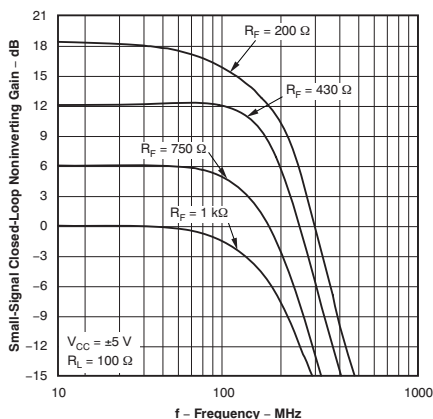

Figure 16.

SMALL-SIGNAL CLOSED-LOOP INVERTING GAIN vs FREQUENCY

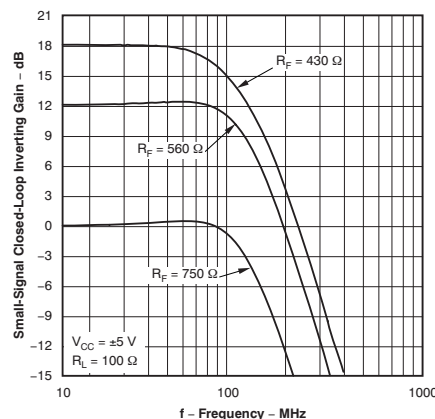

Figure 17.

SMALL-SIGNAL CLOSED-LOOP INVERTING GAIN vs FREQUENCY

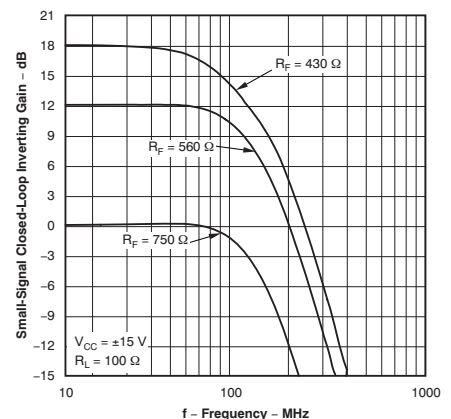

Figure 18.

TYPICAL CHARACTERISTICS (continued)

SMALL- AND LARGE-SIGNAL
OUTPUT
vs FREQUENCY

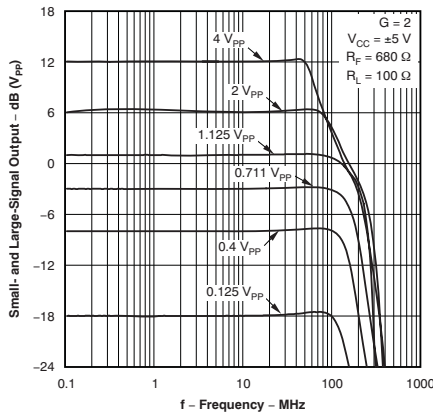

Figure 19.

SMALL- AND LARGE-SIGNAL
OUTPUT
vs FREQUENCY

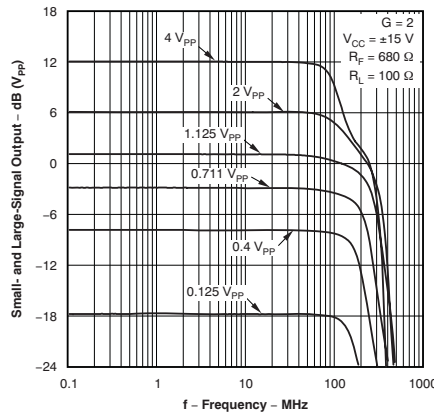

Figure 20.

HARMONIC DISTORTION
vs FREQUENCY

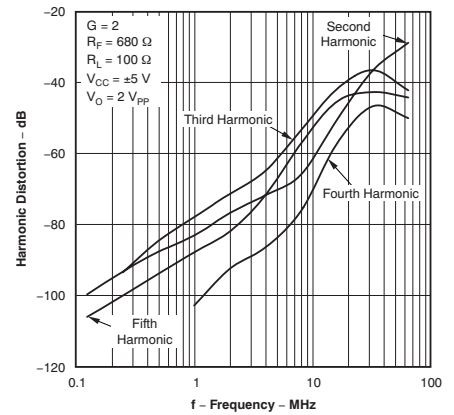

Figure 21.

HARMONIC DISTORTION
vs FREQUENCY

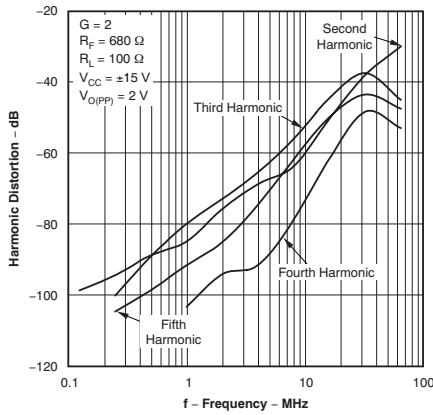

Figure 22.

HARMONIC DISTORTION
vs PEAK-TO-PEAK OUTPUT
VOLTAGE

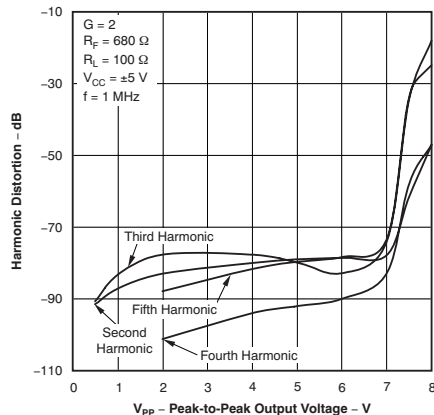

Figure 23.

HARMONIC DISTORTION
vs PEAK-TO-PEAK OUTPUT
VOLTAGE

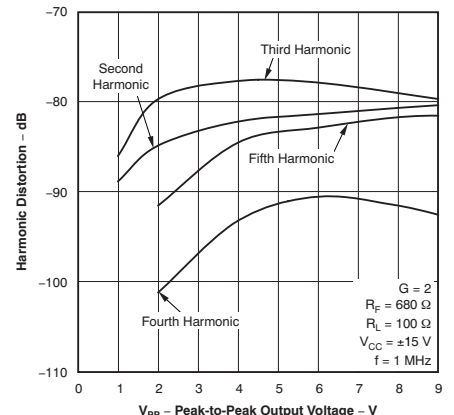

Figure 24.

VOLTAGE NOISE AND CURRENT
NOISE
vs FREQUENCY

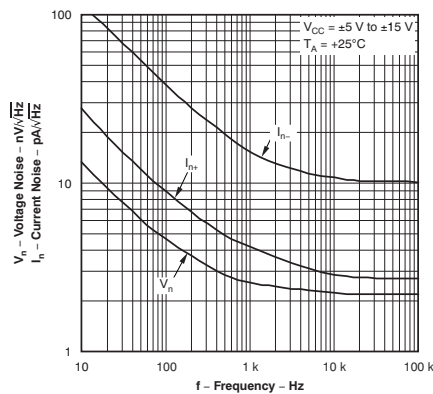

Figure 25.

COMMON-MODE REJECTION RATIO
vs FREQUENCY

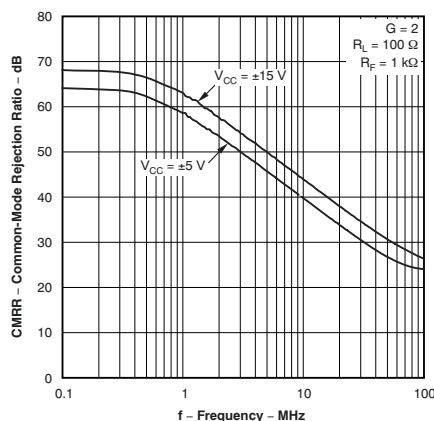

Figure 26.

POWER-SUPPLY REJECTION
RATIO
vs FREQUENCY

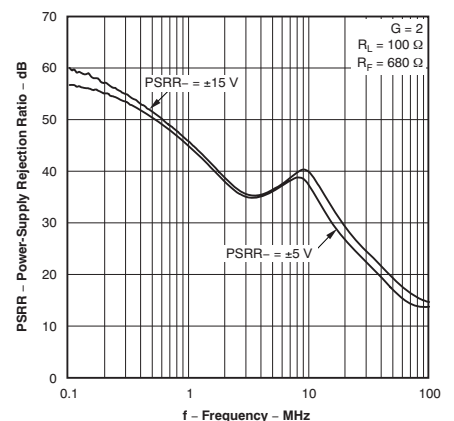

Figure 27.

TYPICAL CHARACTERISTICS (continued)

OUTPUT IMPEDANCE

CROSSTALK vs FREQUENCY

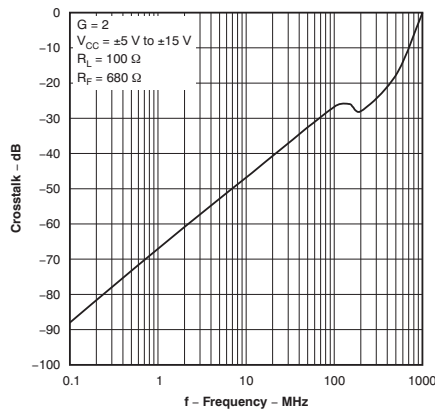

Figure 28.

vs FREQUENCY

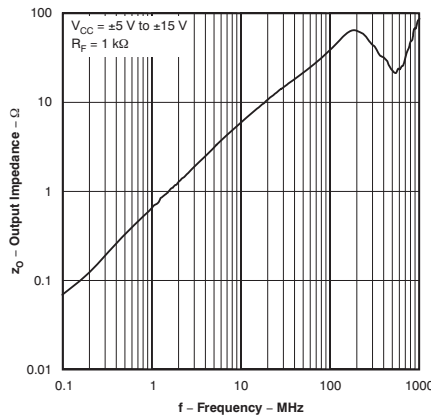

Figure 29.

SLEW RATE vs OUTPUT VOLTAGE STEP

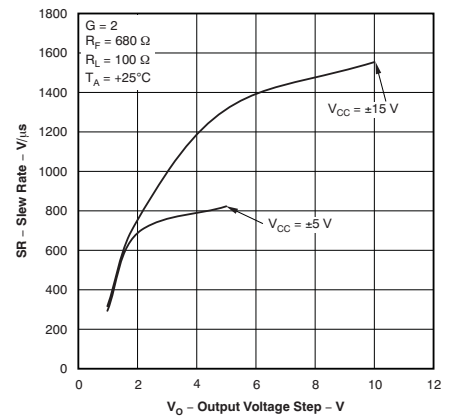

Figure 30.

INPUT OFFSET VOLTAGE vs FREE-AIR TEMPERATURE

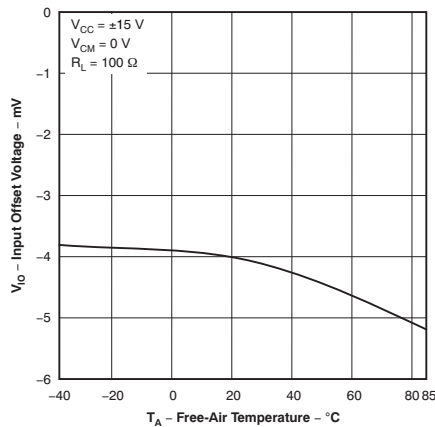

Figure 31.

INPUT OFFSET VOLTAGE vs COMMON-MODE INPUT VOLTAGE

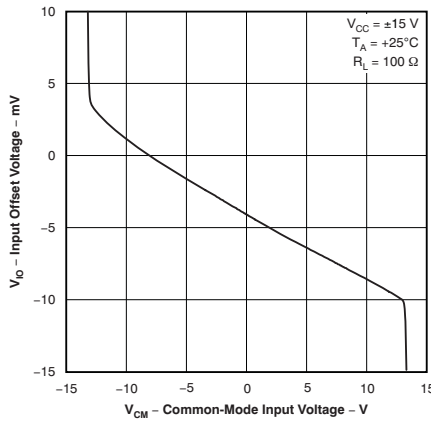

Figure 32.

INPUT BIAS CURRENT vs FREE-AIR TEMPERATURE

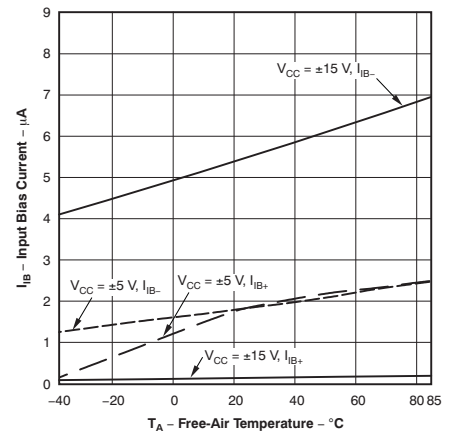

Figure 33.

OUTPUT VOLTAGE vs OUTPUT CURRENT

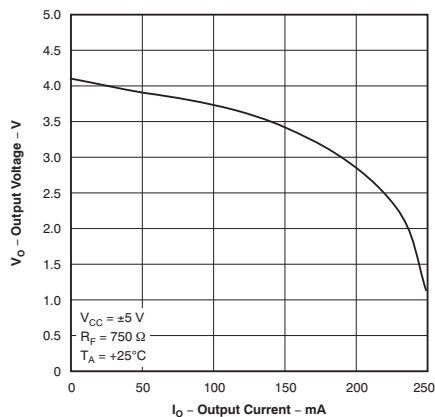

Figure 34.

OUTPUT VOLTAGE vs OUTPUT CURRENT

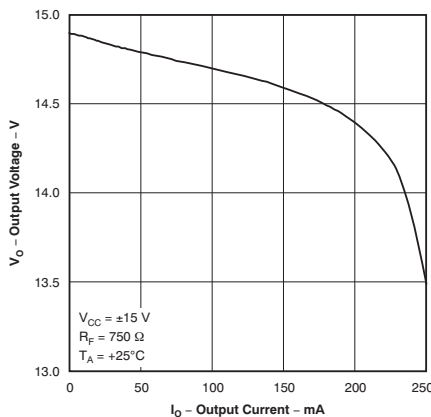

Figure 35.

OUTPUT VOLTAGE HEADROOM vs OUTPUT CURRENT

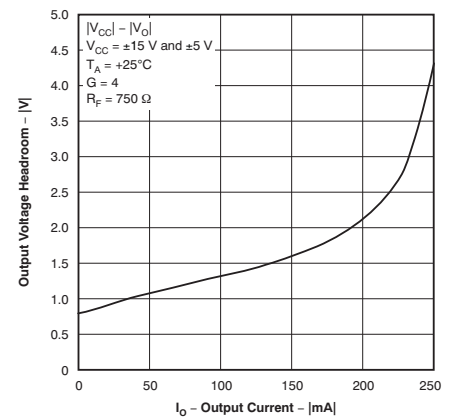

Figure 36.

TYPICAL CHARACTERISTICS (continued)

**SUPPLY CURRENT (PER CHANNEL)
vs SUPPLY VOLTAGE**

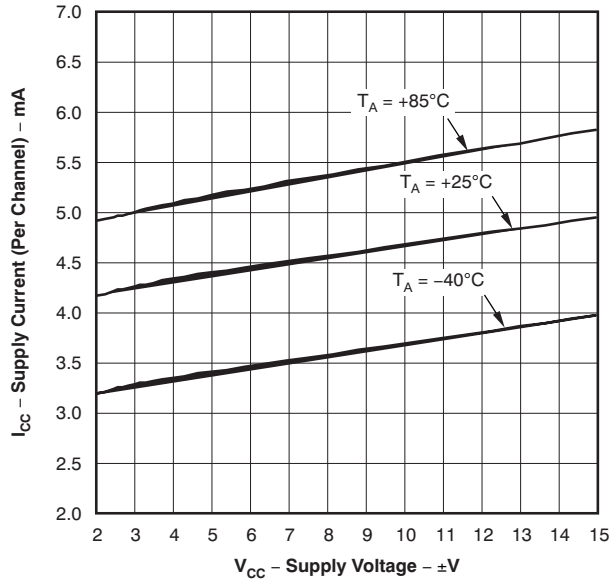

Figure 37.

SHUTDOWN RESPONSE

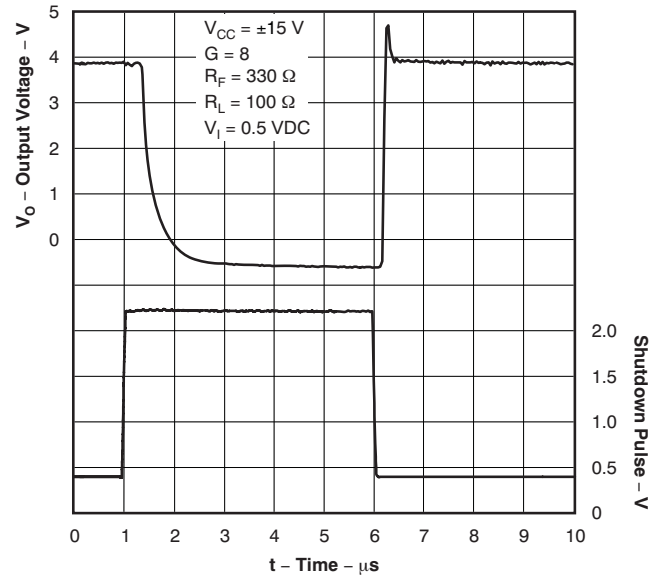

Figure 38.

APPLICATION INFORMATION

Maximum Slew Rate for Repetitive Signals

The THS3115 and THS3112 are recommended for high slew rate pulsed applications where the internal nodes of the amplifier have time to stabilize between pulses. It is recommended to have at least a 20-ns delay between pulses.

The THS3115 and THS3112 are not recommended for applications with repetitive signals (sine, square, sawtooth, or other) that exceed 900 V/μs. Using the part in these applications results in excessive current draw from the power supply and possible device damage.

For applications with high slew rate, repetitive signals, the THS3091 and THS3095 (single versions), or THS3092 and THS3096 (dual versions) are recommended.

Wideband, Noninverting Operation

The THS3115 and THS3112 are unity gain stable 100-MHz current-feedback operational amplifiers, designed to operate from a ±5-V to ±15-V power supply.

Figure 39 shows the THS3115 in a noninverting gain of 2-V/V configuration used to generate the typical characteristic curves. Most of the curves were characterized using signal sources with 50-Ω source impedance and with measurement equipment that presents a 50-Ω load impedance.

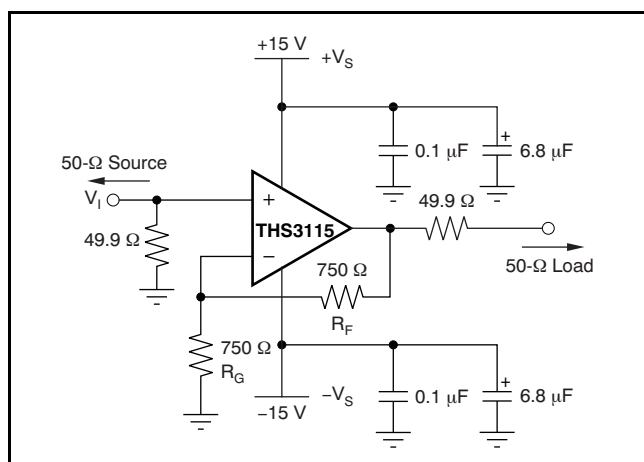

Figure 39. Wideband, Noninverting Gain Configuration

Current-feedback amplifiers are highly dependent on the feedback resistor R_F for maximum performance and stability. Table 1 shows the optimal gain setting resistors R_F and R_G at different gains to give maximum bandwidth with minimal peaking in the frequency response. Higher bandwidths can be achieved, at the expense of added peaking in the frequency response, by using even lower values for R_F . Conversely, increasing R_F decreases the bandwidth, but stability is improved.

Table 1. Recommended Resistor Values for Optimum Frequency Response

THS3115 and THS3112 R_F and R_G VALUES FOR MINIMAL PEAKING WITH $R_L = 50 \Omega$, ± 5 -V to ± 15 -V POWER SUPPLY		
GAIN (V/V)	R_G (Ω)	R_F (Ω)
1	—	1 k
2	750	750
4	187	560
8	28.7	200
–1	750	750
–4	140	560
–8	53.6	430

Wideband, Inverting Operation

Figure 40 shows the THS3115 in a typical inverting gain configuration designed for 50-Ω input/output.

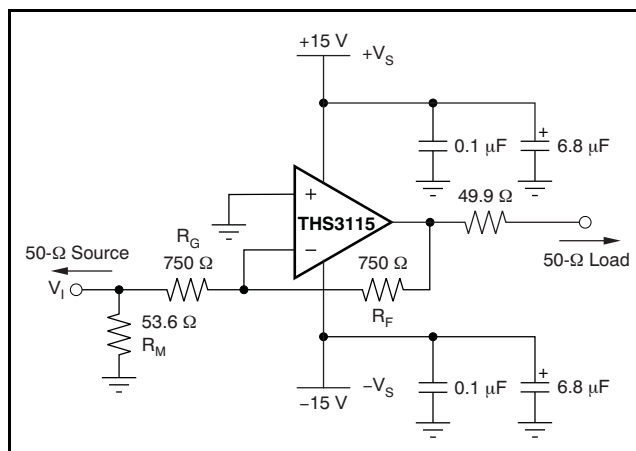

Figure 40. Wideband, Inverting Gain Configuration

Single-Supply Operation

The THS3115 and THS3112 have the capability to operate from a single supply voltage ranging from 10 V to 30 V. When operating from a single power supply, biasing the input and output at mid-supply allows for the maximum output voltage swing. The circuits in Figure 41 show inverting and noninverting amplifiers configured for single-supply operation.

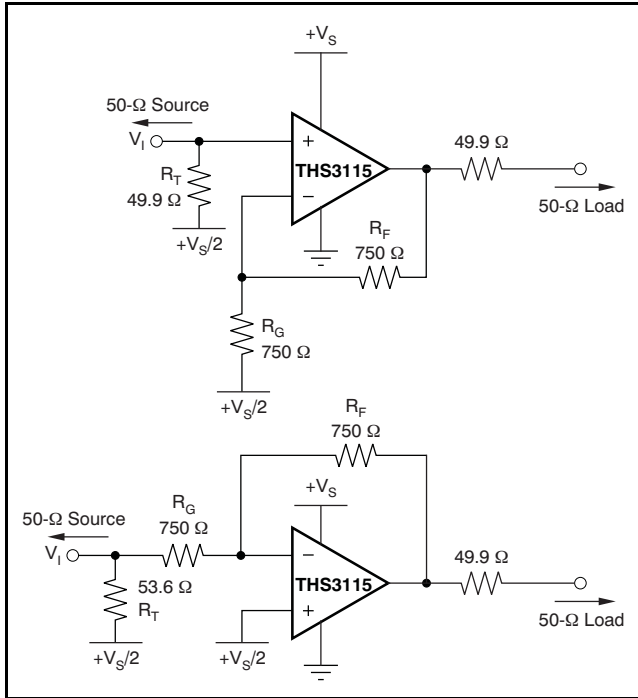

Figure 41. DC-Coupled, Single-Supply Operation

Video Distribution

The wide bandwidth, high slew rate, and high output drive current of the THS3115 and THS3112 match the demands for video distribution to deliver video signals down multiple cables. To ensure high signal quality with minimal degradation of performance, a 0.1-dB gain flatness should be at least 7x the passband frequency to minimize group delay variations from the amplifier. A high slew rate minimizes distortion of the video signal, and supports component video and RGB video signals that require fast transition times and fast settling times for high signal quality. Figure 42 illustrates a typical video distribution amplifier application configuration.

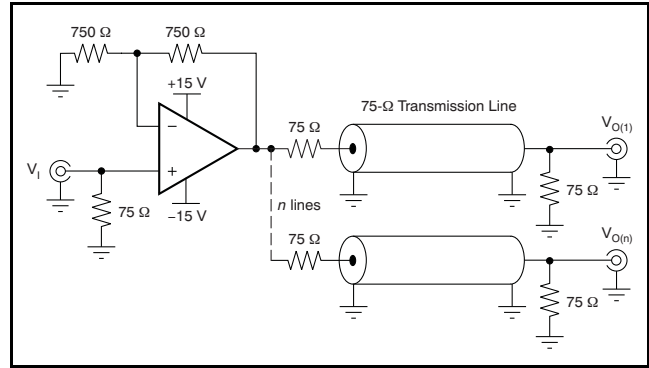

Figure 42. Video Distribution Amplifier Application

Driving Capacitive Loads

Applications such as FET drivers and line drivers can be highly capacitive and cause stability problems for high-speed amplifiers.

Figure 43 through Figure 49 show recommended methods for driving capacitive loads. The basic idea is to use a resistor or ferrite chip to isolate the phase shift at high frequency caused by the capacitive load from the amplifier feedback path. See Figure 43 for recommended resistor values versus capacitive load.

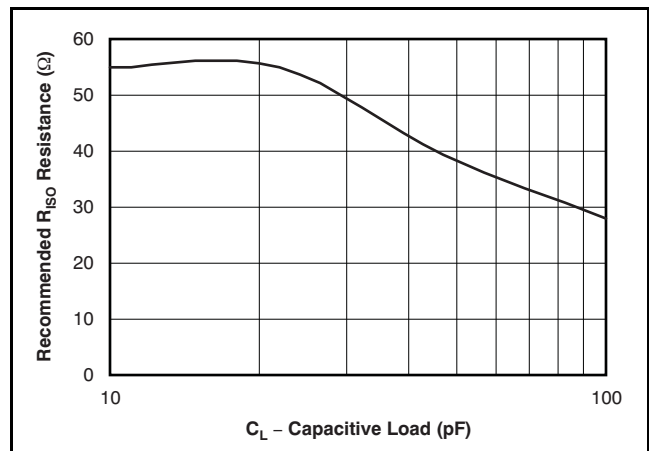

Figure 43. Recommended R_{ISO} vs Capacitive Load

Placing a small series resistor, R_{ISO} , between the amplifier output and the capacitive load, as shown in Figure 44, is an easy way of isolating the load capacitance.

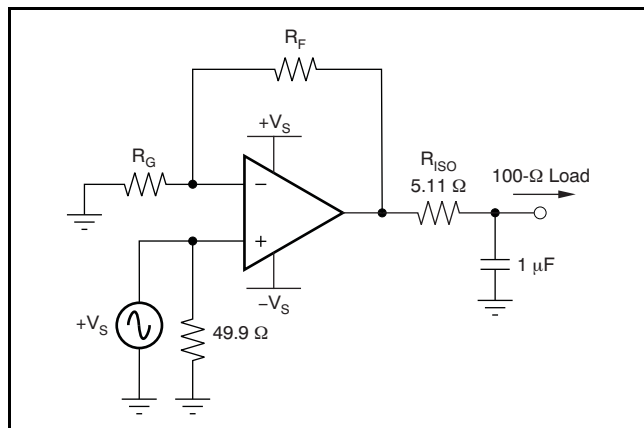

Figure 44. Resistor to Isolate Capacitive Load

Using a ferrite chip in place of R_{ISO} , as Figure 45 shows, is another approach of isolating the output of the amplifier. The ferrite impedance characteristic versus frequency is useful to maintain the low frequency load independence of the amplifier while isolating the phase shift caused by the capacitance at high frequency. Use a ferrite with similar impedance to R_{ISO} , 20 Ω to 50 Ω , at 100 MHz and low impedance at dc.

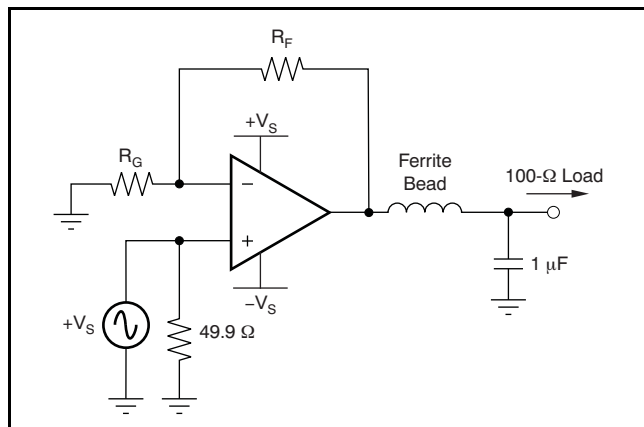

Figure 45. Ferrite Bead to Isolate Capacitive Load

Figure 46 shows another method used to maintain the low-frequency load independence of the amplifier while isolating the phase shift caused by the capacitance at high frequency. At low frequency, feedback is mainly from the load side of R_{ISO} . At high frequency, the feedback is mainly via the 27-pF capacitor. The resistor R_{IN} in series with the negative input is used to stabilize the amplifier and should be equal to the recommended value of R_F at unity gain. Replacing R_{IN} with a ferrite of similar impedance at about 100 MHz as shown in Figure 47 gives similar results with reduced dc offset and low frequency noise.

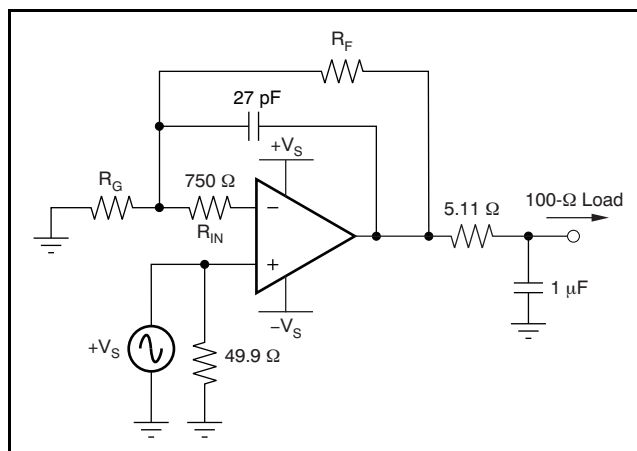

Figure 46. Feedback Technique with Input Resistor for Capacitive Load

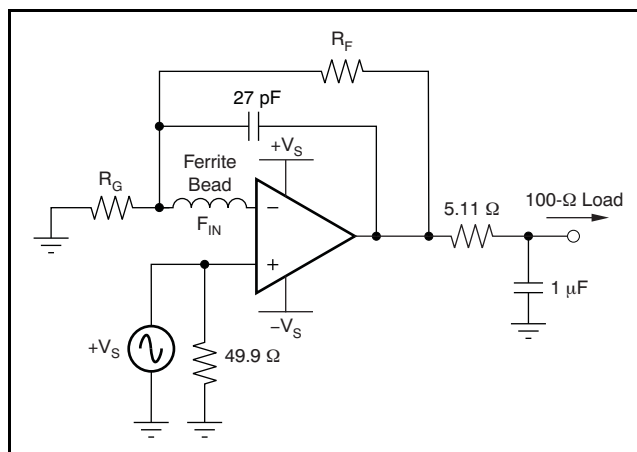

Figure 47. Feedback Technique with Input Ferrite Bead for Capacitive Load

Figure 48 shows a configuration that uses two amplifiers in parallel to double the output drive current to larger capacitive loads. This technique is used when more output current is needed to charge and discharge the load faster as when driving large FET transistors.

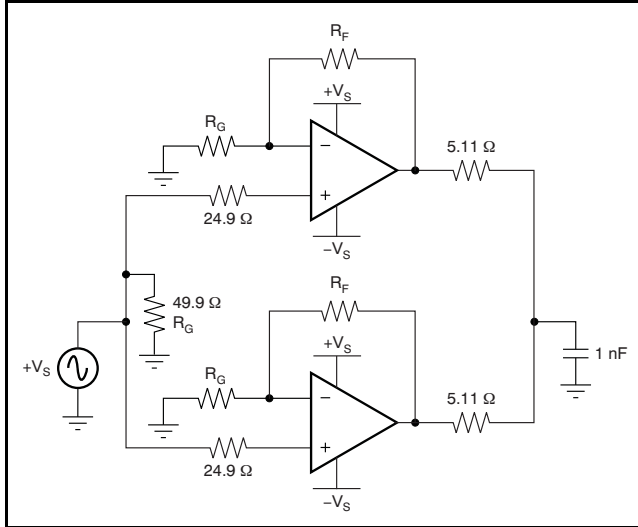

Figure 48. Parallel Amplifiers for Higher Output Drive

Figure 49 shows a push-pull FET driver circuit typical of ultrasound applications with isolation resistors to isolate the gate capacitance from the amplifier.

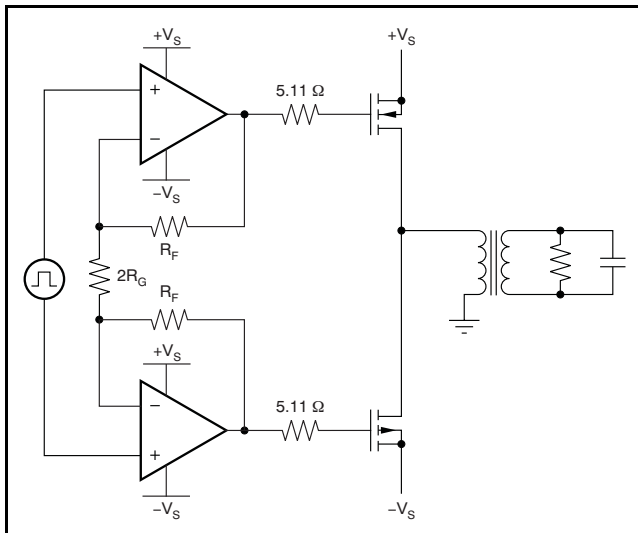

Figure 49. PowerFET Drive Circuit

Saving Power with Shutdown Functionality and Setting Threshold Levels with the Reference Pin

The THS3115 features a shutdown pin (SHUTDOWN) that lowers the quiescent current from 4.9 mA/amp down to 300 μ A/amp, ideal for reducing system power.

The shutdown pin of the amplifier defaults to the REF pin voltage in the absence of an applied voltage, putting the amplifier in the normal on mode of operation. To turn off the amplifier in an effort to conserve power, the shutdown pin can be driven towards the positive rail. The threshold voltages for power-on and power-down (or shutdown) are relative to the supply rails and are given in the [Shutdown Characteristics](#) table. Below the *Enable* threshold voltage, the device is on. Above the *Disable* threshold voltage, the device is off. Behavior between these threshold voltages is not specified.

Note that this shutdown functionality is self-defining: the amplifier consumes less power in shutdown mode. The shutdown mode is not intended to provide a high-impedance output. In other words, the shutdown functionality is not intended to allow use as a 3-state bus driver. When in shutdown mode, the impedance looking back into the output of the amplifier is dominated by the feedback and gain setting resistors, but the output impedance of the device itself varies depending on the voltage applied to the outputs.

As with most current feedback amplifiers, the internal architecture places some limitations on the system when in shutdown mode. Most notably is the fact that the amplifier actually turns *on* if there is a ± 0.7 V or greater difference between the two input nodes (IN+ and IN-) of the amplifier. If this difference exceeds ± 0.7 V, the output of the amplifier creates an output voltage equal to approximately $[(IN+ - IN-) - 0.7V] \times \text{Gain}$. Also, if a voltage is applied to the output while in shutdown mode, the IN- node voltage is equal to $V_{O(\text{applied})} \times R_G / (R_F + R_G)$. For low gain configurations and a large applied voltage at the output, the amplifier may actually turn on because of the behavior described here.

The time delays associated with turning the device on and off are specified as the time it takes for the amplifier to reach either 10% or 90% of the final output voltage. The time delays are in the order of microseconds because the amplifier moves in and out of the linear mode of operation in these transitions.

Power-Down Reference Pin Operation

In addition to the shutdown pin, the THS3115 features a reference pin (REF) which allows the user to control the enable or disable power-down voltage levels applied to the SHUTDOWN pin. In most split-supply applications, the reference pin is connected to ground. In either case, the user needs to be aware of voltage-level thresholds that apply to the shutdown pin. Table 2 shows examples and illustrate the relationship between the reference voltage and the shutdown thresholds. In the table, the threshold levels are derived by the following equations:

$$\text{SHUTDOWN} \leq \text{REF} + 0.8 \text{ V for enable}$$

$$\text{SHUTDOWN} \geq \text{REF} + 2\text{V for disable}$$

Where the usable range at the REF pin is:

$$V_{CC-} \leq V_{REF} \leq (V_{CC+} - 4\text{V})$$

The recommended mode of operation is to tie the REF pin to midrail, therefore setting the enable/disable thresholds to $V_{(\text{midrail})} + 0.8 \text{ V}$ and $V_{(\text{midrail})} = 2 \text{ V}$, respectively.

Table 2. Shutdown Threshold Voltage Levels

SUPPLY VOLTAGE (V)	REFERENCE PIN VOLTAGE (V)	ENABLE LEVEL (V)	DISABLE LEVEL (V)
±15, ±5	0	0.8	2.0
±15	2.0	2.8	4.0
±15	-2.0	-1.2	0
±5	1.0	1.8	3.0
±5	-1.0	-0.2	1.0
+30	15.0	15.8	17
+10	5.0	5.8	7.0

Note that if the REF pin is left unterminated, it floats to the positive rail and falls outside of the recommended operating range given above $V_{CC-} \leq V_{REF} \leq (V_{CC+} - 4\text{V})$. As a result, it no longer serves as a reliable reference for the SHUTDOWN pin, and the enable/disable thresholds given above no longer apply. If the SHUTDOWN pin is also left unterminated, it floats to the positive rail and the device is disabled. If balanced, split supplies are used ($\pm V_{CC}$) and the REF and SHUTDOWN pins are grounded, the device is enabled.

Printed-Circuit Board Layout Techniques for Optimal Performance

Achieving optimum performance with high-frequency amplifiers such as the THS3115 and THS3112 requires careful attention to board layout parasitic and external component types. Recommendations that optimize performance include:

- Minimize parasitic capacitance to any ac ground for all of the signal I/O pins. Parasitic capacitance on the output and input pins can cause instability. To reduce unwanted capacitance, a window around the signal I/O pins should be opened in all of the ground and power planes around those pins. Otherwise, ground and power planes should be unbroken elsewhere on the board.
- Minimize the distance [0.25 inch, (6.4 mm)] from the power-supply pins to high-frequency 0.1- μF and 100-pF decoupling capacitors. At the device pins, the ground and power plane layout should not be in close proximity to the signal I/O pins. Avoid narrow power and ground traces to minimize inductance between the pins and the decoupling capacitors. The power-supply connections should always be decoupled with these capacitors. Larger (6.8 μF or more) tantalum decoupling capacitors, effective at lower frequencies, should also be used on the main supply pins. These capacitors may be placed somewhat farther from the device and may be shared among several devices in the same area of the printed circuit board (PCB).
- Careful selection and placement of external components preserve the high-frequency performance of the THS3115 and THS3112. Resistors should be a very low reactance type. Surface-mount resistors work best and allow a tighter overall layout. Again, keep the leads and PCB trace length as short as possible. Never use wirebound type resistors in a high-frequency application. Because the output pin and inverting input pins are the most sensitive to parasitic capacitance, always position the feedback and series output resistors, if any, as close as possible to the inverting input pins and output pins. Other network components, such as input termination resistors, should be placed close to the gain-setting resistors. Even with a low parasitic capacitance that shunts the external resistors, excessively high resistor values can create significant time constants that can degrade performance. Good axial metal-film or surface-mount resistors have approximately 0.2 pF in shunt with the resistor. For resistor values greater than 2.0 k Ω , this parasitic capacitance can add a pole and/or a zero that can affect circuit operation. Keep resistor values as low as possible, consistent with load driving considerations.

- Connections to other wideband devices on the board may be made with short direct traces or through onboard transmission lines. For short connections, consider the trace and the input to the next device as a lumped capacitive load. Relatively wide traces [0.05 inch (1,3 mm) to 0.1 inch (2,54 mm)] should be used, preferably with ground and power planes opened up around them. Estimate the total capacitive load and determine if isolation resistors on the outputs are necessary. Low parasitic capacitive loads (less than 4 pF) may not need an R_S because the THS3115 and THS3112 are nominally compensated to operate with a 2-pF parasitic load. Higher parasitic capacitive loads without an R_S are allowed as the signal gain increases (thus increasing the unloaded phase margin). If a long trace is required, and the 6-dB signal loss intrinsic to a doubly-terminated transmission line is acceptable, implement a matched-impedance transmission line using microstrip or stripline techniques (consult an ECL design handbook for microstrip and stripline layout techniques). A 50- Ω environment is not necessary onboard, and in fact, a higher impedance environment improves distortion as shown in the distortion versus load plots. With a characteristic board trace impedance based on board material and trace dimensions, a matching series resistor into the trace from the output of the THS3115/THS3112 is used as well as a terminating shunt resistor at the input of the destination device. Remember also that the terminating impedance is the parallel combination of the shunt resistor and the input impedance of the destination device: this total effective impedance should be set to match the trace impedance. If the 6-dB attenuation of a doubly-terminated transmission line is unacceptable, a long trace can be series-terminated at the source end only. Treat the trace as a capacitive load in this case. This configuration does not preserve signal integrity as well as a doubly-terminated line. If the input impedance of the destination device is low, there is some signal attenuation as a result of the voltage divider formed by the series output into the terminating impedance.

- Socketing a high-speed device such as the THS3115 and THS3112 is not recommended. The additional lead length and pin-to-pin capacitance introduced by the socket can create an extremely troublesome parasitic network which can make it almost impossible to achieve a smooth, stable frequency response. Best results are obtained by soldering the THS3115/THS3112 amplifiers directly onto the board.

PowerPAD™ Design Considerations

The THS3115 and THS3112 are available in a thermally-enhanced PowerPAD family of packages. These packages are constructed using a downset leadframe upon which the die is mounted [see Figure 50(a) and Figure 50(b)]. This arrangement results in the lead frame being exposed as a thermal pad on the underside of the package [see Figure 50(c)]. Because this thermal pad has direct thermal contact with the die, excellent thermal performance can be achieved by providing a good thermal path away from the thermal pad. Note that devices such as the THS311x have no electrical connection between the PowerPAD and the die.

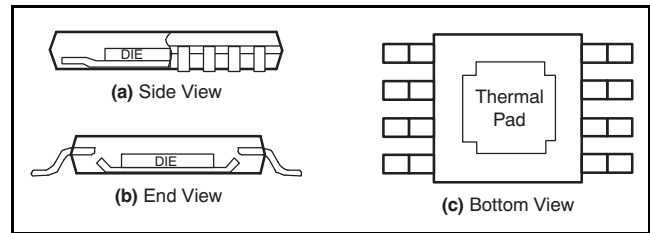

Figure 50. Views of Thermally-Enhanced Package

The PowerPAD package allows for both assembly and thermal management in one manufacturing operation. During the surface-mount solder operation (when the leads are being soldered), the thermal pad can also be soldered to a copper area underneath the package. Through the use of thermal paths within this copper area, heat can be conducted away from the package into either a ground plane or other heat dissipating device.

The PowerPAD package represents a breakthrough in combining the small area and ease of assembly of surface mount with the, heretofore, awkward mechanical methods of heatsinking.

For systems where heat dissipation is more critical, the THS3115 and THS3112 are also available in an 8-pin MSOP with PowerPAD package that offers even better thermal performance. The thermal coefficient for the PowerPAD packages are substantially improved over the traditional SOIC. Maximum power dissipation levels are depicted in Figure 52 for the available packages. The data for the PowerPAD packages assume a board layout that follows the PowerPAD layout guidelines discussed above and detailed in the PowerPAD application note (literature number SLMA002). Figure 52 also illustrates the effect of not soldering the PowerPAD to a PCB. The thermal impedance increases substantially, which may cause serious heat and performance issues. Always solder the PowerPAD to the PCB for optimum performance.

When determining whether or not the device satisfies the maximum power dissipation requirement, it is important to not only consider quiescent power dissipation, but also dynamic power dissipation. Often times, this type of dissipation is difficult to quantify because the signal pattern is inconsistent, but an estimate of the RMS power dissipation can provide visibility into a possible problem.

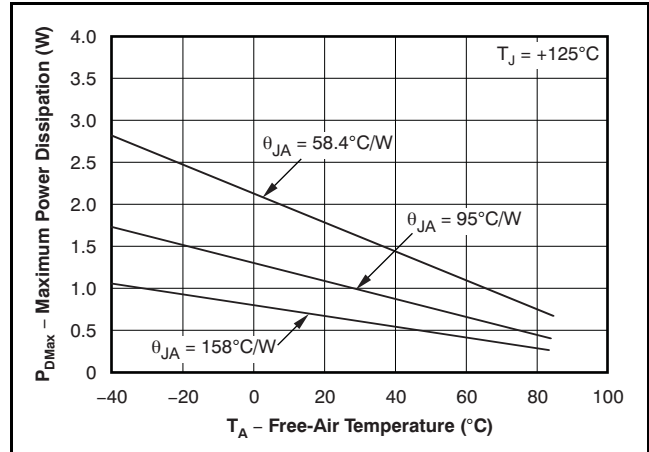

Results shown are with no air flow and PCB size of 3 in x 3 in (76,2 mm x 76,2 mm).

- $\theta_{JA} = 58.4^\circ\text{C/W}$ for 8-pin MSOP with PowerPAD (DGN package)
- $\theta_{JA} = 95^\circ\text{C/W}$ for 8-pin SOIC High-K test PCB (D package)
- $\theta_{JA} = 158^\circ\text{C/W}$ for 8-pin MSOP with PowerPAD without solder

Figure 52. Maximum Power Dissipation vs Ambient Temperature

REVISION HISTORY

NOTE: Page numbers for previous revisions may differ from page numbers in the current version.

Changes from Revision B (October, 2009) to Revision C	Page
• Corrected pin designations for TSSOP pinout drawing	1
• Deleted <i>Shutdown pin input levels</i> parameters from Recommended Operating Conditions table	3
• Added V_{REF} parameter to Shutdown Characteristics table	5
• Added V_{SHDN} parameter to Shutdown Characteristics table	5
• Changed reference to GND pin to "REF" in <i>Shutdown quiescent current</i> parameter test conditions in Shutdown Characteristics table	5
• Added REF = 0 V to test conditions for $I_{IL(SHDN)}$ parameter in Shutdown Characteristics table	5
• Added REF = 0 V to test conditions for $I_{IH(SHDN)}$ parameter in Shutdown Characteristics table	5
• Revised Saving Power with Shutdown Functionality and Setting Threshold Levels with the Reference Pin section	14
• Updated Power-Down Reference Pin Operation section; changed references to V_{S-} , V_{S+} to V_{CC-} , V_{CC+}	15

Changes from Revision A (January, 2009) to Revision B	Page
• Updated document format to conform to current standards	1
• Deleted lead temperature specification from <i>Absolute Maximum Ratings</i> table	2
• Added <i>Application Information</i> section	11

PACKAGING INFORMATION

Orderable Device	Status (1)	Package Type	Package Drawing	Pins	Package Qty	Eco Plan (2)	Lead finish/ Ball material (6)	MSL Peak Temp (3)	Op Temp (°C)	Device Marking (4/5)	Samples
THS3112CD	ACTIVE	SOIC	D	8	75	RoHS & Green	NIPDAU	Level-1-260C-UNLIM	0 to 70	3112C	Samples
THS3112CDDA	ACTIVE	SO PowerPAD	DDA	8	75	RoHS & Green	SN	Level-1-260C-UNLIM	0 to 70	3112C	Samples
THS3112CDR	ACTIVE	SOIC	D	8	2500	RoHS & Green	NIPDAU	Level-1-260C-UNLIM	0 to 70	3112C	Samples
THS3112CDRG4	ACTIVE	SOIC	D	8	2500	RoHS & Green	NIPDAU	Level-1-260C-UNLIM	0 to 70	3112C	Samples
THS3112ID	ACTIVE	SOIC	D	8	75	RoHS & Green	NIPDAU	Level-1-260C-UNLIM	-40 to 85	3112I	Samples
THS3112IDDA	ACTIVE	SO PowerPAD	DDA	8	75	RoHS & Green	SN	Level-1-260C-UNLIM	-40 to 85	3112I	Samples
THS3112IDDAR	ACTIVE	SO PowerPAD	DDA	8	2500	RoHS & Green	SN	Level-1-260C-UNLIM	-40 to 85	3112I	Samples
THS3115CPWP	ACTIVE	HTSSOP	PWP	14	90	RoHS & Green	NIPDAU	Level-2-260C-1 YEAR	0 to 70	HS3115C	Samples
THS3115CPWPR	ACTIVE	HTSSOP	PWP	14	2000	RoHS & Green	NIPDAU	Level-2-260C-1 YEAR	0 to 70	HS3115C	Samples
THS3115ID	ACTIVE	SOIC	D	14	50	RoHS & Green	NIPDAU	Level-1-260C-UNLIM	-40 to 85	THS3115I	Samples
THS3115IPWP	ACTIVE	HTSSOP	PWP	14	90	RoHS & Green	NIPDAU	Level-2-260C-1 YEAR	-40 to 85	HS3115I	Samples
THS3115IPWPG4	ACTIVE	HTSSOP	PWP	14	90	RoHS & Green	NIPDAU	Level-2-260C-1 YEAR	-40 to 85	HS3115I	Samples
THS3115IPWPR	ACTIVE	HTSSOP	PWP	14	2000	RoHS & Green	NIPDAU	Level-2-260C-1 YEAR	-40 to 85	HS3115I	Samples
THS3115IPWPRG4	ACTIVE	HTSSOP	PWP	14	2000	RoHS & Green	NIPDAU	Level-2-260C-1 YEAR	-40 to 85	HS3115I	Samples

(1) The marketing status values are defined as follows:

ACTIVE: Product device recommended for new designs.

LIFEBUY: TI has announced that the device will be discontinued, and a lifetime-buy period is in effect.

NRND: Not recommended for new designs. Device is in production to support existing customers, but TI does not recommend using this part in a new design.

PREVIEW: Device has been announced but is not in production. Samples may or may not be available.

OBSOLETE: TI has discontinued the production of the device.

(2) **RoHS:** TI defines "RoHS" to mean semiconductor products that are compliant with the current EU RoHS requirements for all 10 RoHS substances, including the requirement that RoHS substance do not exceed 0.1% by weight in homogeneous materials. Where designed to be soldered at high temperatures, "RoHS" products are suitable for use in specified lead-free processes. TI may reference these types of products as "Pb-Free".

RoHS Exempt: TI defines "RoHS Exempt" to mean products that contain lead but are compliant with EU RoHS pursuant to a specific EU RoHS exemption.

Green: TI defines "Green" to mean the content of Chlorine (Cl) and Bromine (Br) based flame retardants meet JS709B low halogen requirements of ≤ 1000 ppm threshold. Antimony trioxide based flame retardants must also meet the ≤ 1000 ppm threshold requirement.

(3) MSL, Peak Temp. - The Moisture Sensitivity Level rating according to the JEDEC industry standard classifications, and peak solder temperature.

(4) There may be additional marking, which relates to the logo, the lot trace code information, or the environmental category on the device.

(5) Multiple Device Markings will be inside parentheses. Only one Device Marking contained in parentheses and separated by a "~" will appear on a device. If a line is indented then it is a continuation of the previous line and the two combined represent the entire Device Marking for that device.

(6) Lead finish/Ball material - Orderable Devices may have multiple material finish options. Finish options are separated by a vertical ruled line. Lead finish/Ball material values may wrap to two lines if the finish value exceeds the maximum column width.

Important Information and Disclaimer: The information provided on this page represents TI's knowledge and belief as of the date that it is provided. TI bases its knowledge and belief on information provided by third parties, and makes no representation or warranty as to the accuracy of such information. Efforts are underway to better integrate information from third parties. TI has taken and continues to take reasonable steps to provide representative and accurate information but may not have conducted destructive testing or chemical analysis on incoming materials and chemicals. TI and TI suppliers consider certain information to be proprietary, and thus CAS numbers and other limited information may not be available for release.

In no event shall TI's liability arising out of such information exceed the total purchase price of the TI part(s) at issue in this document sold by TI to Customer on an annual basis.

TAPE AND REEL INFORMATION

QUADRANT ASSIGNMENTS FOR PIN 1 ORIENTATION IN TAPE



*All dimensions are nominal

Device	Package Type	Package Drawing	Pins	SPQ	Reel Diameter (mm)	Reel Width W1 (mm)	A0 (mm)	B0 (mm)	K0 (mm)	P1 (mm)	W (mm)	Pin1 Quadrant
THS3112CDR	SOIC	D	8	2500	330.0	12.4	6.4	5.2	2.1	8.0	12.0	Q1
THS3112IDDAR	SO Power PAD	DDA	8	2500	330.0	12.4	6.4	5.2	2.1	8.0	12.0	Q1
THS3115CPWPR	HTSSOP	PWP	14	2000	330.0	12.4	6.9	5.6	1.6	8.0	12.0	Q1
THS3115IPWPR	HTSSOP	PWP	14	2000	330.0	12.4	6.9	5.6	1.6	8.0	12.0	Q1

TAPE AND REEL BOX DIMENSIONS

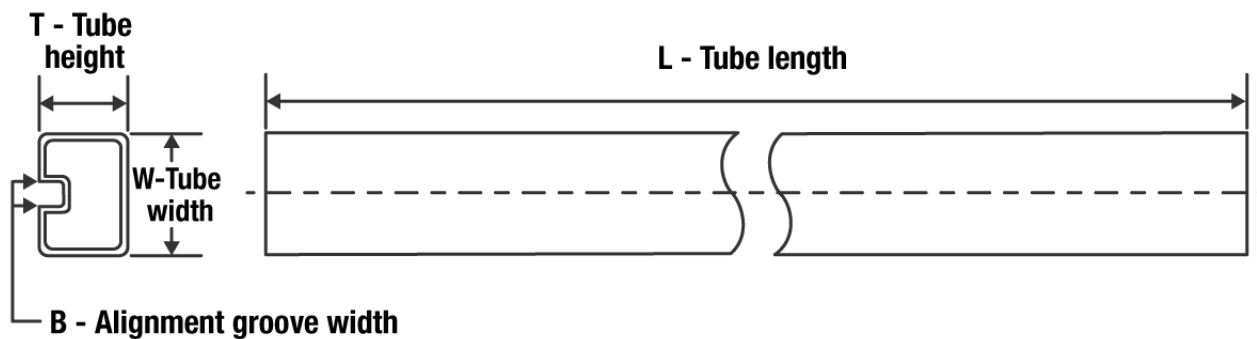

*All dimensions are nominal

Device	Package Type	Package Drawing	Pins	SPQ	Length (mm)	Width (mm)	Height (mm)
THS3112CDR	SOIC	D	8	2500	350.0	350.0	43.0
THS3112IDDAR	SO PowerPAD	DDA	8	2500	350.0	350.0	43.0
THS3115CPWPR	HTSSOP	PWP	14	2000	350.0	350.0	43.0
THS3115IPWPR	HTSSOP	PWP	14	2000	350.0	350.0	43.0

TUBE

*All dimensions are nominal

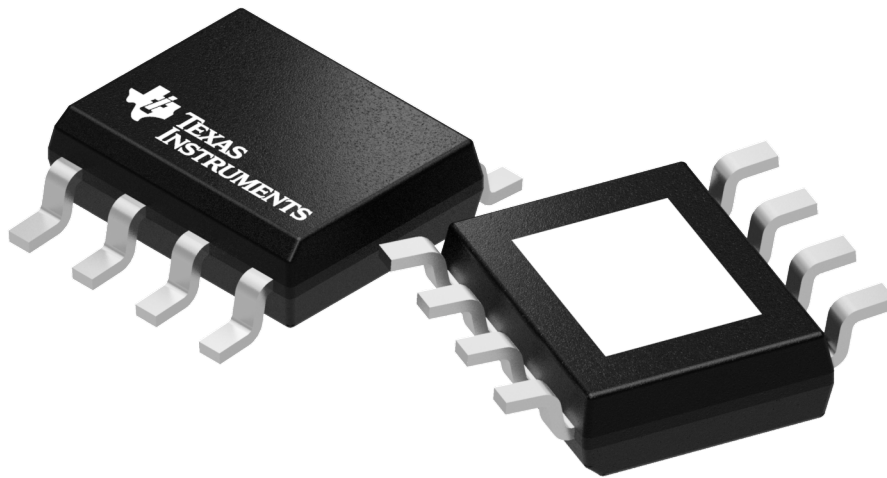
Device	Package Name	Package Type	Pins	SPQ	L (mm)	W (mm)	T (μm)	B (mm)
THS3112CD	D	SOIC	8	75	505.46	6.76	3810	4
THS3112CDDA	DDA	HSOIC	8	75	505.46	6.76	3810	4
THS3112ID	D	SOIC	8	75	505.46	6.76	3810	4
THS3112IDDA	DDA	HSOIC	8	75	505.46	6.76	3810	4
THS3115CPWP	PWP	HTSSOP	14	90	530	10.2	3600	3.5
THS3115ID	D	SOIC	14	50	505.46	6.76	3810	4
THS3115IPWP	PWP	HTSSOP	14	90	530	10.2	3600	3.5
THS3115IPWPG4	PWP	HTSSOP	14	90	530	10.2	3600	3.5



Images above are just a representation of the package family, actual package may vary.
Refer to the product data sheet for package details.

DDA0008B



PACKAGE OUTLINE

PowerPAD™ SOIC - 1.7 mm max height

PLASTIC SMALL OUTLINE

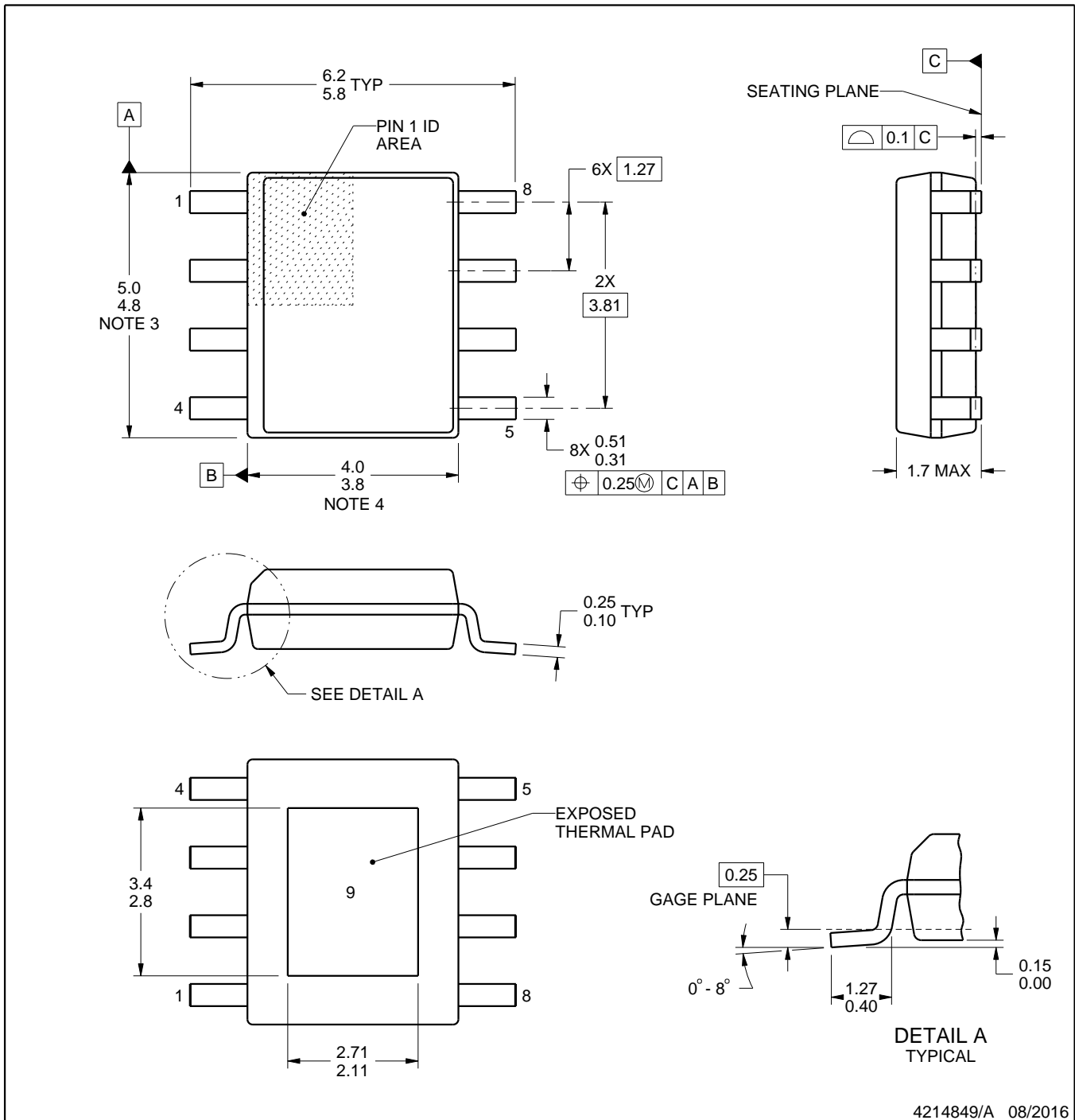

4214849/A 08/2016

PowerPAD is a trademark of Texas Instruments.

NOTES:

1. All linear dimensions are in millimeters. Any dimensions in parenthesis are for reference only. Dimensioning and tolerancing per ASME Y14.5M.
2. This drawing is subject to change without notice.
3. This dimension does not include mold flash, protrusions, or gate burrs. Mold flash, protrusions, or gate burrs shall not exceed 0.15 mm per side.
4. This dimension does not include interlead flash. Interlead flash shall not exceed 0.25 mm per side.
5. Reference JEDEC registration MS-012.

EXAMPLE BOARD LAYOUT

DDA0008B

PowerPAD™ SOIC - 1.7 mm max height

PLASTIC SMALL OUTLINE

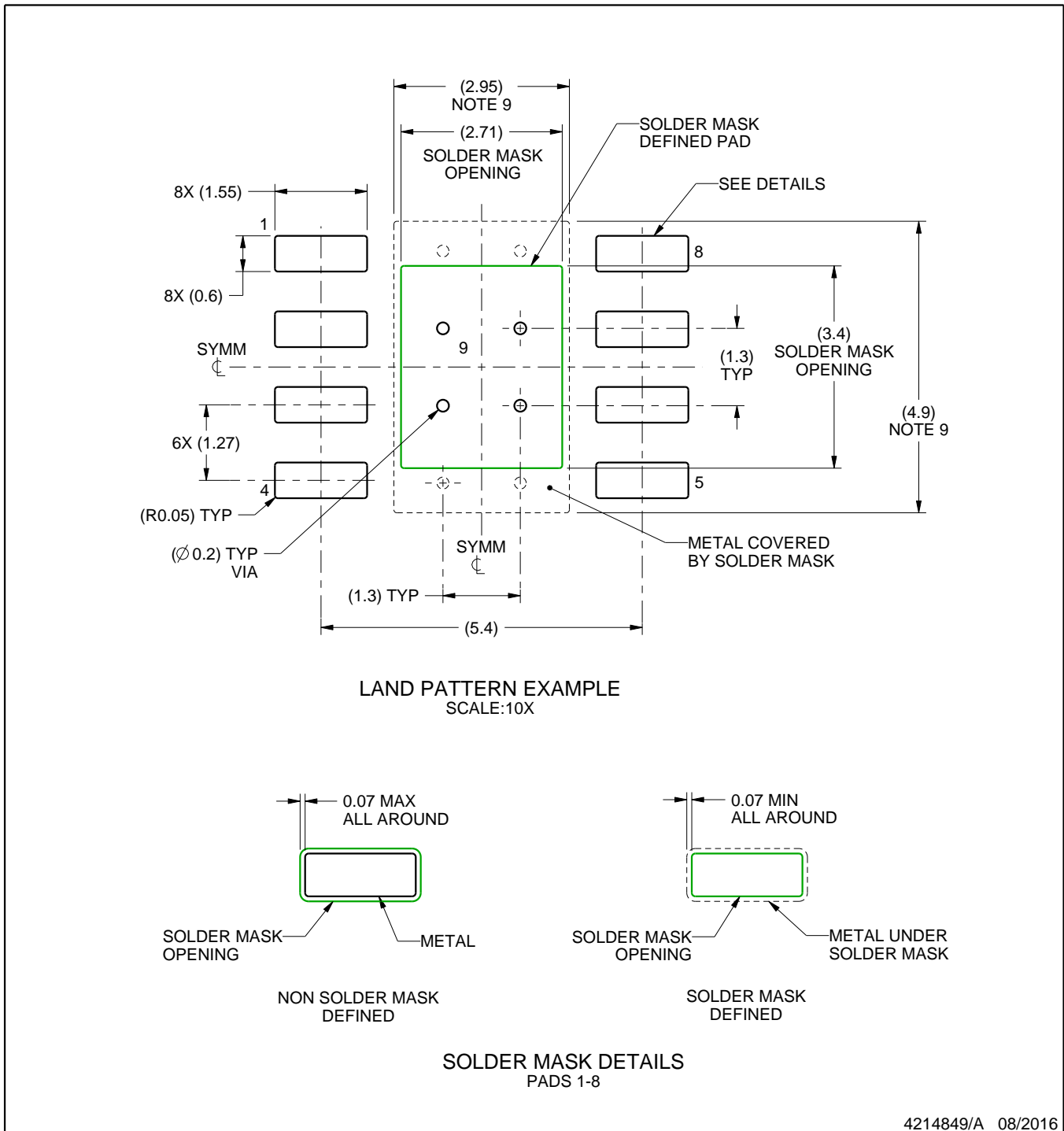

4214849/A 08/2016

NOTES: (continued)

6. Publication IPC-7351 may have alternate designs.
7. Solder mask tolerances between and around signal pads can vary based on board fabrication site.
8. This package is designed to be soldered to a thermal pad on the board. For more information, see Texas Instruments literature numbers SLMA002 (www.ti.com/lit/slma002) and SLMA004 (www.ti.com/lit/slma004).
9. Size of metal pad may vary due to creepage requirement.
10. Vias are optional depending on application, refer to device data sheet. If any vias are implemented, refer to their locations shown on this view. It is recommended that vias under paste be filled, plugged or tented.

EXAMPLE STENCIL DESIGN

DDA0008B

PowerPAD™ SOIC - 1.7 mm max height

PLASTIC SMALL OUTLINE

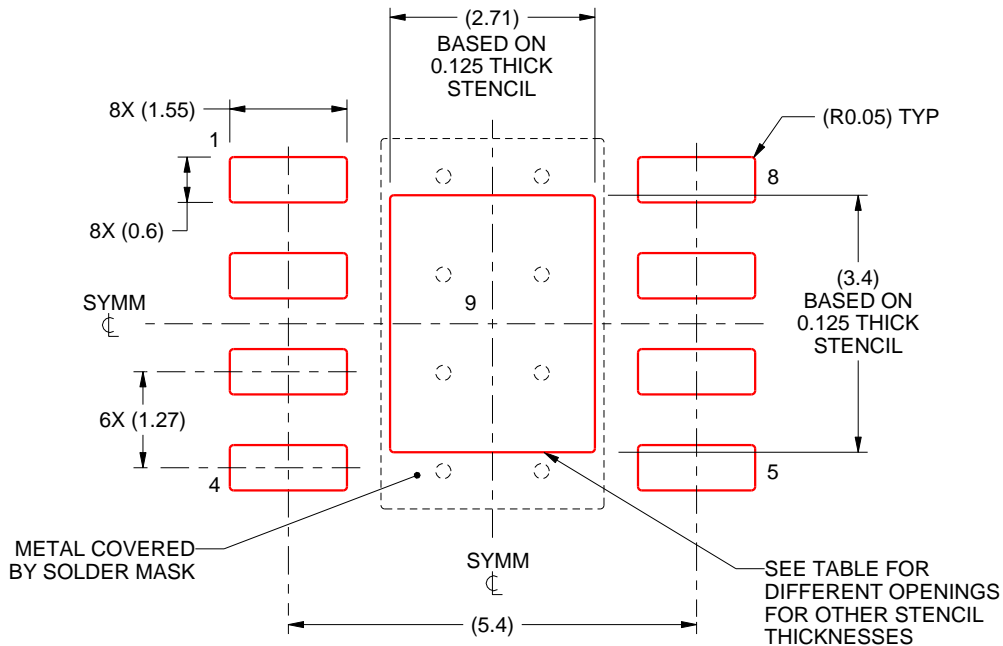

SOLDER PASTE EXAMPLE
 EXPOSED PAD
 100% PRINTED SOLDER COVERAGE BY AREA
 SCALE:10X

STENCIL THICKNESS	SOLDER STENCIL OPENING
0.1	3.03 X 3.80
0.125	2.71 X 3.40 (SHOWN)
0.150	2.47 X 3.10
0.175	2.29 X 2.87

4214849/A 08/2016

NOTES: (continued)

11. Laser cutting apertures with trapezoidal walls and rounded corners may offer better paste release. IPC-7525 may have alternate design recommendations.
12. Board assembly site may have different recommendations for stencil design.

D (R-PDSO-G14)

PLASTIC SMALL OUTLINE



- NOTES:
- A. All linear dimensions are in inches (millimeters).
 - B. This drawing is subject to change without notice.
 -  Body length does not include mold flash, protrusions, or gate burrs. Mold flash, protrusions, or gate burrs shall not exceed 0.006 (0,15) each side.
 -  Body width does not include interlead flash. Interlead flash shall not exceed 0.017 (0,43) each side.
 - E. Reference JEDEC MS-012 variation AB.

D (R-PDSO-G14)

PLASTIC SMALL OUTLINE

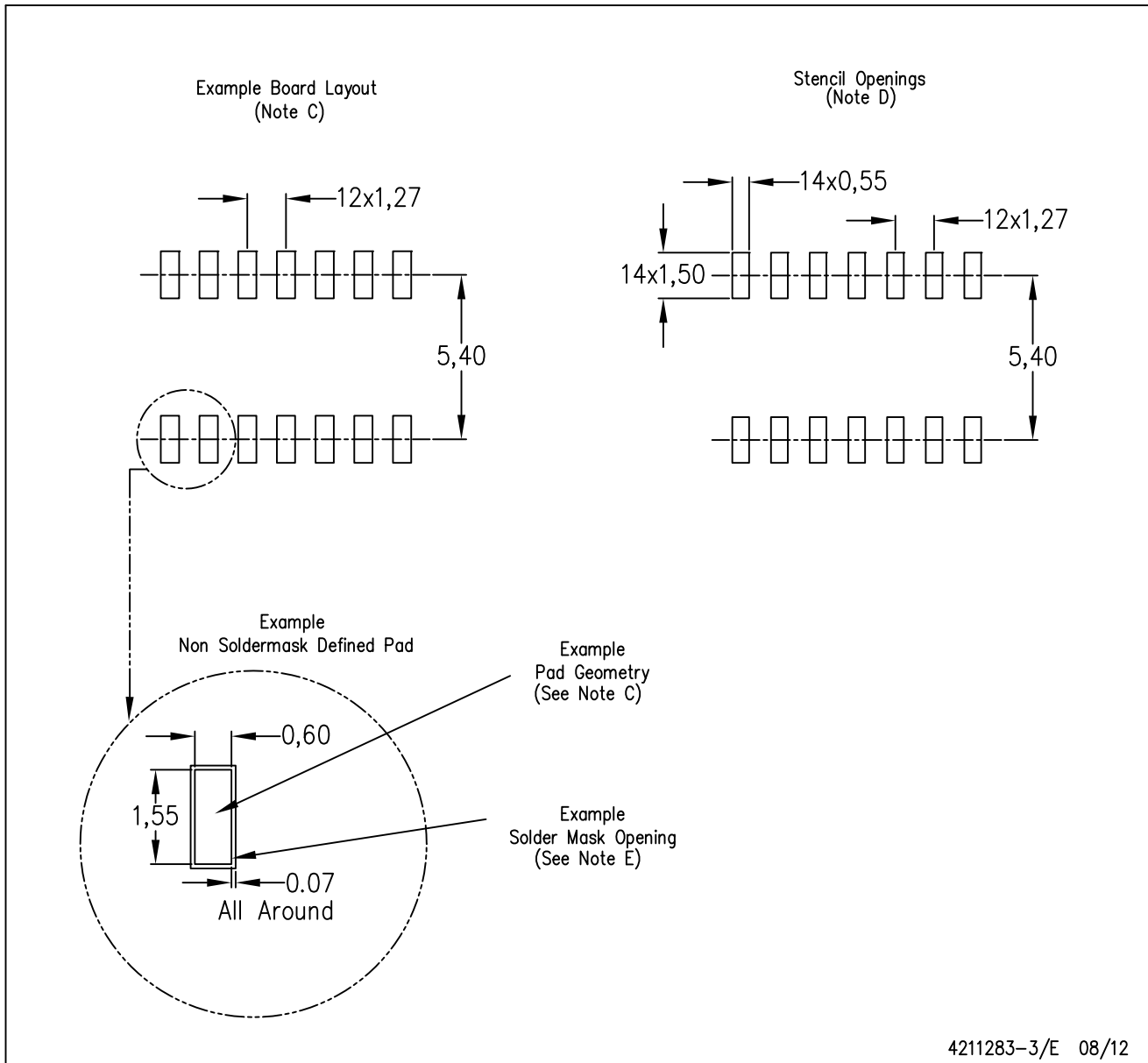

4211283-3/E 08/12

- NOTES:
- All linear dimensions are in millimeters.
 - This drawing is subject to change without notice.
 - Publication IPC-7351 is recommended for alternate designs.
 - Laser cutting apertures with trapezoidal walls and also rounding corners will offer better paste release. Customers should contact their board assembly site for stencil design recommendations. Refer to IPC-7525 for other stencil recommendations.
 - Customers should contact their board fabrication site for solder mask tolerances between and around signal pads.

PWP (R-PDSO-G14)

PowerPAD™ PLASTIC SMALL OUTLINE

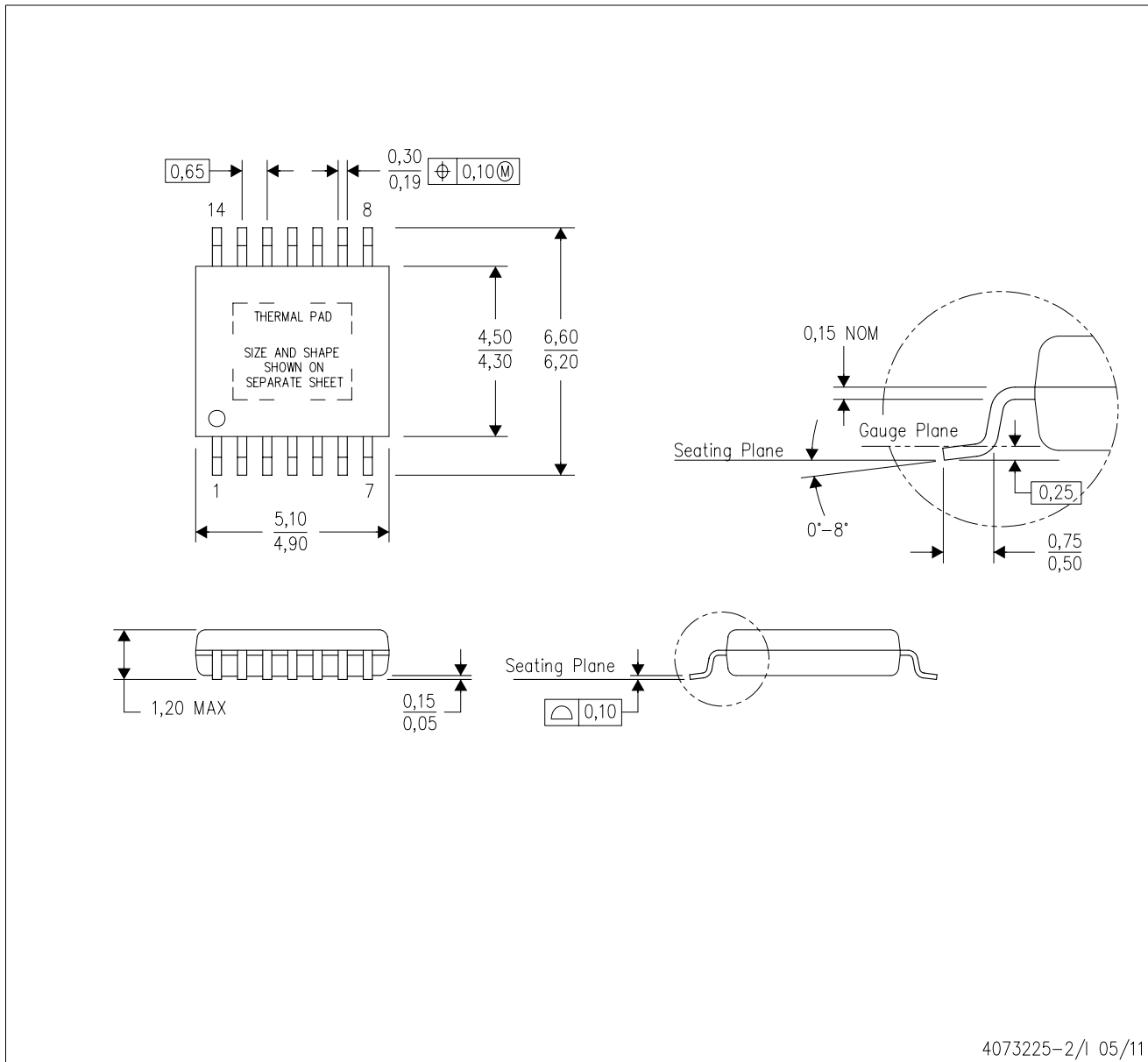

4073225-2/1 05/11

- NOTES:
- All linear dimensions are in millimeters.
 - This drawing is subject to change without notice.
 - Body dimensions do not include mold flash or protrusions. Mold flash and protrusion shall not exceed 0.15 per side.
 - This package is designed to be soldered to a thermal pad on the board. Refer to Technical Brief, PowerPad Thermally Enhanced Package, Texas Instruments Literature No. SLMA002 for information regarding recommended board layout. This document is available at www.ti.com <<http://www.ti.com>>.
 - See the additional figure in the Product Data Sheet for details regarding the exposed thermal pad features and dimensions.
 - Falls within JEDEC MO-153

PowerPAD is a trademark of Texas Instruments.

THERMAL PAD MECHANICAL DATA

PWP (R-PDSO-G14)

PowerPAD™ SMALL PLASTIC OUTLINE

THERMAL INFORMATION

This PowerPAD™ package incorporates an exposed thermal pad that is designed to be attached to a printed circuit board (PCB). The thermal pad must be soldered directly to the PCB. After soldering, the PCB can be used as a heatsink. In addition, through the use of thermal vias, the thermal pad can be attached directly to the appropriate copper plane shown in the electrical schematic for the device, or alternatively, can be attached to a special heatsink structure designed into the PCB. This design optimizes the heat transfer from the integrated circuit (IC).

For additional information on the PowerPAD package and how to take advantage of its heat dissipating abilities, refer to Technical Brief, PowerPAD Thermally Enhanced Package, Texas Instruments Literature No. SLMA002 and Application Brief, PowerPAD Made Easy, Texas Instruments Literature No. SLMA004. Both documents are available at www.ti.com.

The exposed thermal pad dimensions for this package are shown in the following illustration.

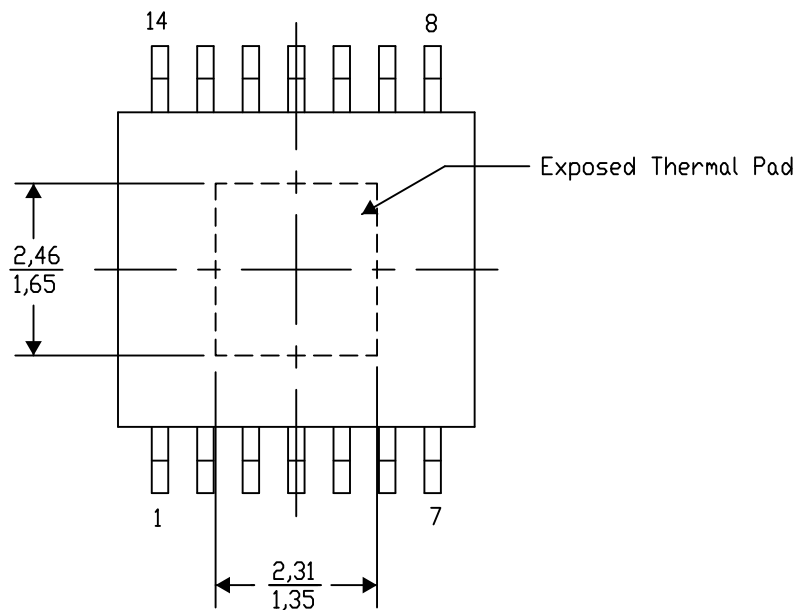

Top View

Exposed Thermal Pad Dimensions

4206332-2/AO 01/16

NOTE: A. All linear dimensions are in millimeters

PowerPAD is a trademark of Texas Instruments

PWP (R-PDSO-G14)

PowerPAD™ PLASTIC SMALL OUTLINE

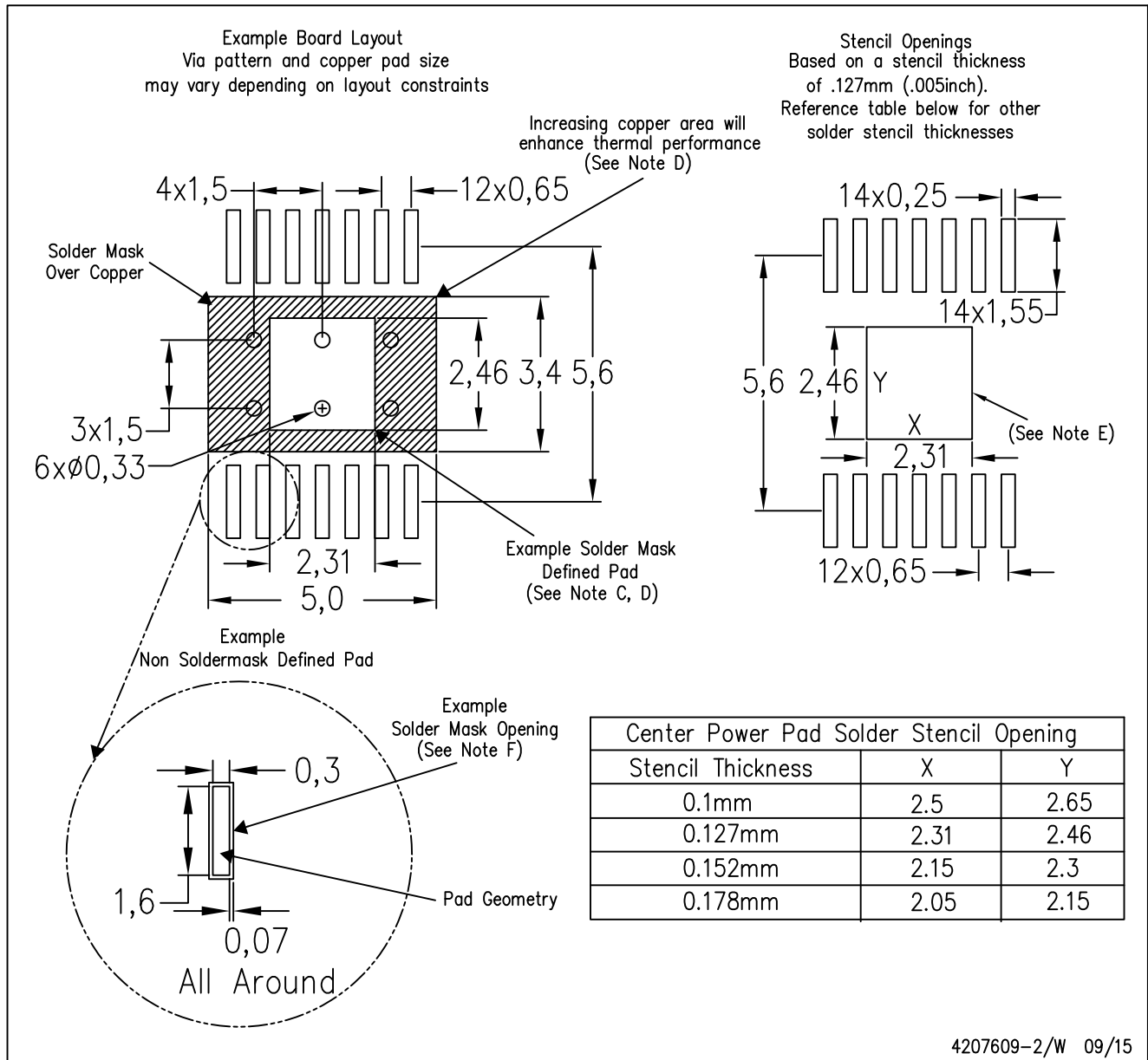

- NOTES:
- A. All linear dimensions are in millimeters.
 - B. This drawing is subject to change without notice.
 - C. Customers should place a note on the circuit board fabrication drawing not to alter the center solder mask defined pad.
 - D. This package is designed to be soldered to a thermal pad on the board. Refer to Technical Brief, PowerPAD Thermally Enhanced Package, Texas Instruments Literature No. SLMA002, SLMA004, and also the Product Data Sheets for specific thermal information, via requirements, and recommended board layout. These documents are available at www.ti.com <<http://www.ti.com>>. Publication IPC-7351 is recommended for alternate designs.
 - E. Laser cutting apertures with trapezoidal walls and also rounding corners will offer better paste release. Customers should contact their board assembly site for stencil design recommendations. Example stencil design based on a 50% volumetric metal load solder paste. Refer to IPC-7525 for other stencil recommendations.
 - F. Customers should contact their board fabrication site for solder mask tolerances between and around signal pads.

THERMAL PAD MECHANICAL DATA

PWP (R-PDSO-G14)

PowerPAD™ SMALL PLASTIC OUTLINE

THERMAL INFORMATION

This PowerPAD™ package incorporates an exposed thermal pad that is designed to be attached to a printed circuit board (PCB). The thermal pad must be soldered directly to the PCB. After soldering, the PCB can be used as a heatsink. In addition, through the use of thermal vias, the thermal pad can be attached directly to the appropriate copper plane shown in the electrical schematic for the device, or alternatively, can be attached to a special heatsink structure designed into the PCB. This design optimizes the heat transfer from the integrated circuit (IC).

For additional information on the PowerPAD package and how to take advantage of its heat dissipating abilities, refer to Technical Brief, PowerPAD Thermally Enhanced Package, Texas Instruments Literature No. SLMA002 and Application Brief, PowerPAD Made Easy, Texas Instruments Literature No. SLMA004. Both documents are available at www.ti.com.

The exposed thermal pad dimensions for this package are shown in the following illustration.

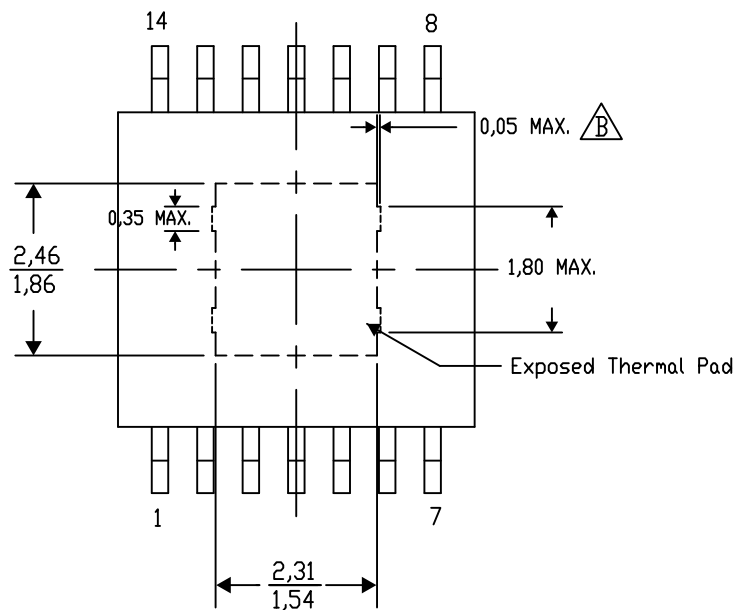

Top View

Exposed Thermal Pad Dimensions

4206332-44/AO 01/16

NOTE: A. All linear dimensions are in millimeters

 Exposed tie strap features may not be present.

PowerPAD is a trademark of Texas Instruments

PWP (R-PDSO-G14)

PowerPAD™ PLASTIC SMALL OUTLINE

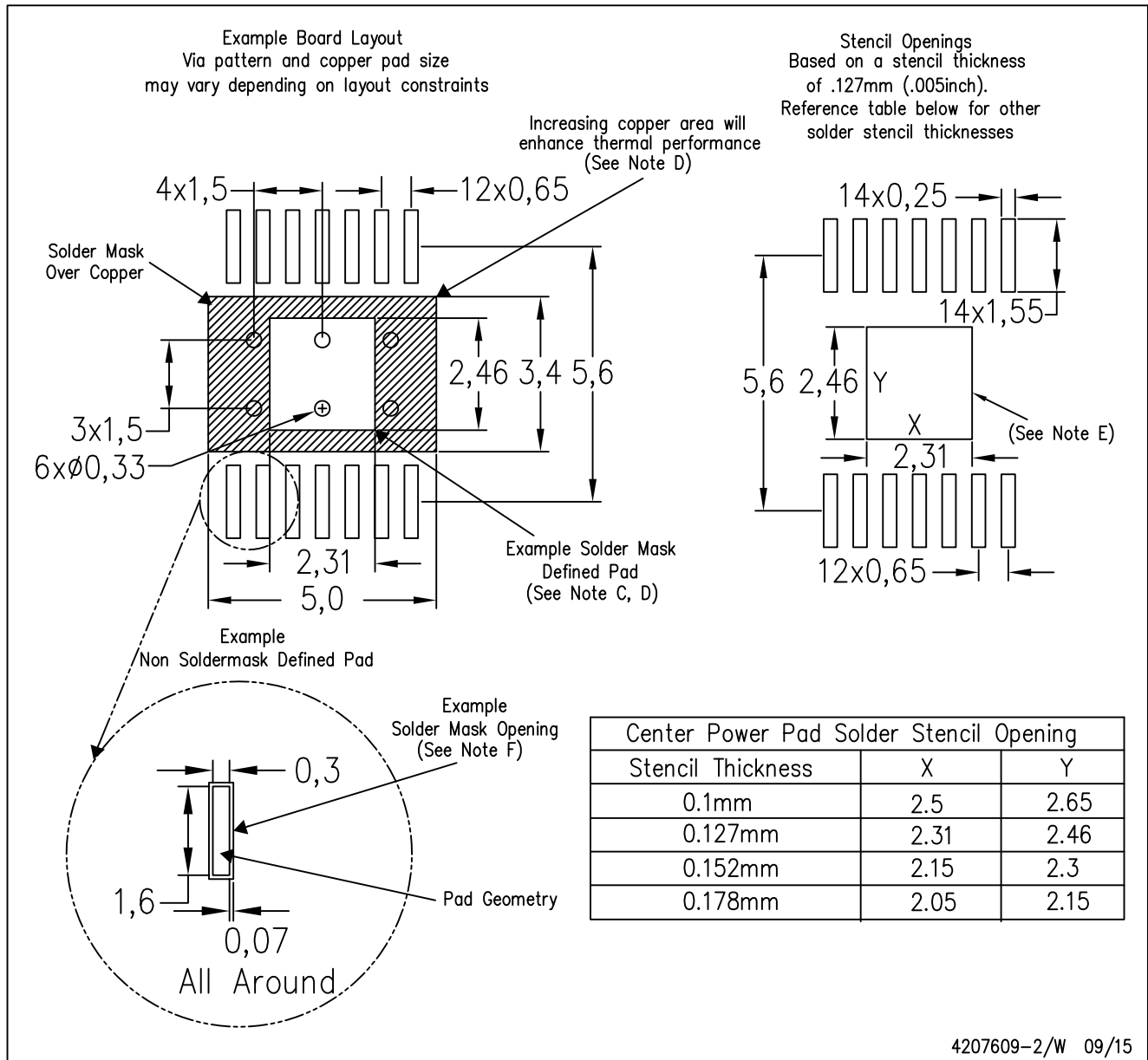

- NOTES:
- A. All linear dimensions are in millimeters.
 - B. This drawing is subject to change without notice.
 - C. Customers should place a note on the circuit board fabrication drawing not to alter the center solder mask defined pad.
 - D. This package is designed to be soldered to a thermal pad on the board. Refer to Technical Brief, PowerPAD Thermally Enhanced Package, Texas Instruments Literature No. SLMA002, SLMA004, and also the Product Data Sheets for specific thermal information, via requirements, and recommended board layout. These documents are available at www.ti.com <<http://www.ti.com>>. Publication IPC-7351 is recommended for alternate designs.
 - E. Laser cutting apertures with trapezoidal walls and also rounding corners will offer better paste release. Customers should contact their board assembly site for stencil design recommendations. Example stencil design based on a 50% volumetric metal load solder paste. Refer to IPC-7525 for other stencil recommendations.
 - F. Customers should contact their board fabrication site for solder mask tolerances between and around signal pads.



D0008A

PACKAGE OUTLINE

SOIC - 1.75 mm max height

SMALL OUTLINE INTEGRATED CIRCUIT



4214825/C 02/2019

NOTES:

- Linear dimensions are in inches [millimeters]. Dimensions in parenthesis are for reference only. Controlling dimensions are in inches. Dimensioning and tolerancing per ASME Y14.5M.
- This drawing is subject to change without notice.
- This dimension does not include mold flash, protrusions, or gate burrs. Mold flash, protrusions, or gate burrs shall not exceed $.006$ [0.15] per side.
- This dimension does not include interlead flash.
- Reference JEDEC registration MS-012, variation AA.

EXAMPLE BOARD LAYOUT

D0008A

SOIC - 1.75 mm max height

SMALL OUTLINE INTEGRATED CIRCUIT



LAND PATTERN EXAMPLE
 EXPOSED METAL SHOWN
 SCALE:8X



SOLDER MASK DETAILS

4214825/C 02/2019

NOTES: (continued)

- 6. Publication IPC-7351 may have alternate designs.
- 7. Solder mask tolerances between and around signal pads can vary based on board fabrication site.

EXAMPLE STENCIL DESIGN

D0008A

SOIC - 1.75 mm max height

SMALL OUTLINE INTEGRATED CIRCUIT



SOLDER PASTE EXAMPLE
BASED ON .005 INCH [0.125 MM] THICK STENCIL
SCALE:8X

4214825/C 02/2019

NOTES: (continued)

8. Laser cutting apertures with trapezoidal walls and rounded corners may offer better paste release. IPC-7525 may have alternate design recommendations.
9. Board assembly site may have different recommendations for stencil design.

IMPORTANT NOTICE AND DISCLAIMER

TI PROVIDES TECHNICAL AND RELIABILITY DATA (INCLUDING DATA SHEETS), DESIGN RESOURCES (INCLUDING REFERENCE DESIGNS), APPLICATION OR OTHER DESIGN ADVICE, WEB TOOLS, SAFETY INFORMATION, AND OTHER RESOURCES "AS IS" AND WITH ALL FAULTS, AND DISCLAIMS ALL WARRANTIES, EXPRESS AND IMPLIED, INCLUDING WITHOUT LIMITATION ANY IMPLIED WARRANTIES OF MERCHANTABILITY, FITNESS FOR A PARTICULAR PURPOSE OR NON-INFRINGEMENT OF THIRD PARTY INTELLECTUAL PROPERTY RIGHTS.

These resources are intended for skilled developers designing with TI products. You are solely responsible for (1) selecting the appropriate TI products for your application, (2) designing, validating and testing your application, and (3) ensuring your application meets applicable standards, and any other safety, security, regulatory or other requirements.

These resources are subject to change without notice. TI grants you permission to use these resources only for development of an application that uses the TI products described in the resource. Other reproduction and display of these resources is prohibited. No license is granted to any other TI intellectual property right or to any third party intellectual property right. TI disclaims responsibility for, and you will fully indemnify TI and its representatives against, any claims, damages, costs, losses, and liabilities arising out of your use of these resources.

TI's products are provided subject to [TI's Terms of Sale](#) or other applicable terms available either on ti.com or provided in conjunction with such TI products. TI's provision of these resources does not expand or otherwise alter TI's applicable warranties or warranty disclaimers for TI products.

TI objects to and rejects any additional or different terms you may have proposed.

Mailing Address: Texas Instruments, Post Office Box 655303, Dallas, Texas 75265
Copyright © 2022, Texas Instruments Incorporated