

LMK00334 四路输出 PCIe/第 1 代/第 2 代/第 3 代/第 4 代/第 5 代时钟缓冲器和电平转换器

1 特性

- 3:1 输入多路复用器
 - 两个通用输入运行频率高达 400MHz，且接受 LVPECL、LVDS、CML、SSTL、HSTL、HCSL 或单端时钟
 - 单个晶体输入可接受 10MHz 至 40MHz 的晶体或单端时钟
- 分为两组，每组具有两路差分输出
 - HCSL 或 Hi-Z (可选)
 - 100MHz 时 PCIe 第 5 代的附加 RMS 相位抖动：
 - 15fs RMS (典型值)
- 高 PSRR：156.25MHz 时为 -72 dBc
- 通过同步使能输入提供 LVCMOS 输出
- 由引脚控制的配置
- V_{CC} 内核电源：3.3V \pm 5%
- 三个独立的 V_{CCO} 输出电源：3.3V、2.5V \pm 5%
- 工业温度范围：-40°C 至 +105°C
- 32 引脚 WQFN (5 mm \times 5 mm)

2 应用

- 面向 ADC、DAC、多千兆以太网、XAUI、光纤通道、SATA/SAS、SONET/SDH、CPRI 和 高频背板的时钟分配和电平转换
- 交换机、路由器、线路接口卡、定时卡
- 服务器、计算、PCI express (PCIe 3.0、4.0、5.0)
- 远程无线电单元和基带单元

3 说明

LMK00334 器件是一款 4 路输出 HCSL 扇出缓冲器，旨在用于高频、低抖动时钟、数据分配和电平转换。可从两个通用输入或一个晶振输入中选择输入时钟。所选择的输入时钟被分配到由两个 HCSL 输出和一个 LVCMOS 输出组成的两个组。LVCMOS 输出具有同步使能输入，在使能或禁用后可实现无短脉冲运行。LMK00334 由一个 3.3V 内核电源和三个独立的 3.3V 或 2.5V 输出电源供电运行。

LMK00334 具有高性能、多用途和高功效特性，因此堪称替代固定输出缓冲器器件的理想选择，同时还能增加系统中的时序余裕。

器件信息(1)

器件型号	封装	封装尺寸 (标称值)
LMK00334	WQFN (32)	5.00mm \times 5.00mm

(1) 如需了解所有可用封装，请参阅数据表末尾的可订购产品附录。

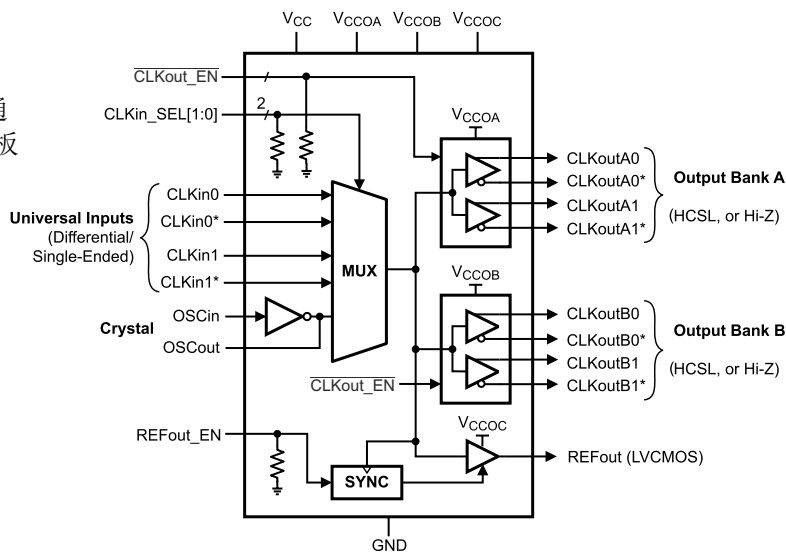

LMK00334 功能框图



Table of Contents

1 特性	1	9 Application and Implementation	15
2 应用	1	9.1 Application Information.....	15
3 说明	1	9.2 Typical Application.....	15
4 Revision History	2	10 Power Supply Recommendations	20
5 Pin Configuration and Functions	3	10.1 Current Consumption and Power Dissipation Calculations.....	20
6 Specifications	4	10.2 Power Supply Bypassing.....	22
6.1 Absolute Maximum Ratings.....	4	11 Layout	23
6.2 ESD Ratings.....	4	11.1 Layout Guidelines.....	23
6.3 Recommended Operating Conditions.....	5	11.2 Layout Example.....	23
6.4 Thermal Information.....	5	11.3 Thermal Management.....	24
6.5 Electrical Characteristics.....	5	12 Device and Documentation Support	25
6.6 Timing Requirements, Propagation Delay, and Output Skew.....	8	12.1 Documentation Support.....	25
6.7 Typical Characteristics.....	9	12.2 接收文档更新通知.....	25
7 Parameter Measurement Information	11	12.3 支持资源.....	25
7.1 Differential Voltage Measurement Terminology.....	11	12.4 Trademarks.....	25
8 Detailed Description	12	12.5 Electrostatic Discharge Caution.....	25
8.1 Overview.....	12	12.6 术语表.....	25
8.2 Functional Block Diagram.....	12	13 Mechanical, Packaging, and Orderable Information	25
8.3 Feature Description.....	12		
8.4 Device Functional Modes.....	14		

4 Revision History

Changes from Revision C (July 2017) to Revision D (July 2021)	Page
• 更新了整个文档中的表格、图和交叉参考的编号格式.....	1
• 在数据表中添加了 PCIe 第 5.0 代.....	1
• Corrected PN in 图 9-4 and 图 9-5 to LMK00334.....	17
Changes from Revision B (May 2017) to Revision C (July 2017)	Page
• Added PCIe 4.0 compliance data.....	5
Changes from Revision A (October 2014) to Revision B (May 2017)	Page
• 已将整个数据表中的 CLKout_EN 引脚更改为 $\overline{\text{CLKout_EN}}$	1
• Add pins 28 and 32 to the <i>Pin Functions</i> table	3
• Moved the storage temperature to the <i>Absolute Maximum Ratings</i> table.....	4
• Added test conditions to the output supply voltage parameter in the <i>Recommended Operating Conditions</i> table.....	5
Changes from Revision * (December 2013) to Revision A (October 2014)	Page
• 添加、更新或重命名了以下各个部分：器件信息表、应用和实施；电源建议；布局；器件和文档支持；机械、 封装和可订购信息	1
• Changed from 1 MHz to 12 kHz in <i>Electrical Characteristics</i>	5
• Deleted "The additive jitter The additive RMS jitter was approximated ... ".....	5

5 Pin Configuration and Functions



图 5-1. RTV Package 32-Pin WQFN Top View

表 5-1. Pin Functions⁽³⁾

PIN		I/O	DESCRIPTION
NAME	NO.		
DAP	DAP	GND	Die Attach Pad. Connect to the PCB ground plane for heat dissipation.
CLKin_SEL0	13	I	Clock input selection pins ⁽²⁾
CLKin_SEL1	16	I	Clock input selection pins ⁽²⁾
CLKin0	14	I	Universal clock input 0 (differential/single-ended)
CLKin0*	15	I	Universal clock input 0 (differential/single-ended)
CLKin1	27	I	Universal clock input 1 (differential/single-ended)
CLKin1*	26	I	Universal clock input 1 (differential/single-ended)
CLKout_EN	9	I	Bank A and Bank B low active output buffer enable. ⁽²⁾
CLKoutA0	3	O	Differential clock output A0.
CLKoutA0*	4	O	Differential clock output A0.
CLKoutA1	6	O	Differential clock output A1.
CLKoutA1*	7	O	Differential clock output A1.
CLKoutB1	19	O	Differential clock output B1.
CLKoutB1*	18	O	Differential clock output B1.
CLKoutB0	22	O	Differential clock output B0.
CLKoutB0*	21	O	Differential clock output B0.
GND	1, 8 17, 24	GND	Ground
NC	25	—	Not connected internally. Pin may be floated, grounded, or otherwise tied to any potential within the Supply Voltage range stated in the Absolute Maximum Ratings .
OSCin	11	I	Input for crystal. Can also be driven by a XO, TCXO, or other external single-ended clock.
OSCout	12	O	Output for crystal. Leave OSCout floating if OSCin is driven by a single-ended clock.
REFout	29	O	LVC MOS reference output. Enable output by pulling REFout_EN pin high.
REFout_EN	31	I	REFout enable input. Enable signal is internally synchronized to selected clock input. ⁽²⁾

表 5-1. Pin Functions⁽³⁾ (continued)

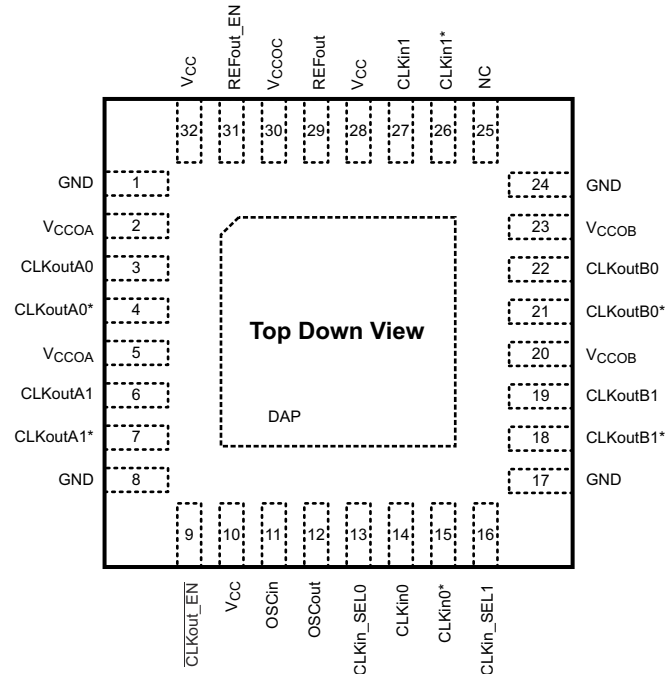
PIN		I/O	DESCRIPTION
NAME	NO.		
V _{CC}	10, 28, 32	PWR	Power supply for Core and Input Buffer blocks. The V _{CC} supply operates from 3.3 V. Bypass with a 0.1-μF, low-ESR capacitor placed very close to each V _{CC} pin.
V _{CCOA}	2, 5	PWR	Power supply for Bank A Output buffers. V _{CCOA} operates from 3.3 V or 2.5 V. The V _{CCOA} pins are internally tied together. Bypass with a 0.1-μF, low-ESR capacitor placed very close to each V _{CCO} pin. ⁽¹⁾
V _{CCOB}	20, 23	PWR	Power supply for Bank B Output buffers. V _{CCOB} operates from 3.3 V or 2.5 V. The V _{CCOB} pins are internally tied together. Bypass with a 0.1-μF, low-ESR capacitor placed very close to each V _{CCO} pin. ⁽¹⁾
V _{CCOC}	30	PWR	Power supply for REFout buffer. V _{CCOC} operates from 3.3 V or 2.5 V. Bypass with a 0.1-μF, low-ESR capacitor placed very close to each V _{CCO} pin. ⁽¹⁾

- (1) The output supply voltages or pins (V_{CCOA}, V_{CCOB}, and V_{CCOC}) will be called V_{CCO} in general when no distinction is needed, or when the output supply can be inferred from the output bank/type.
- (2) CMOS control input with internal pulldown resistor.
- (3) Any unused output pins should be left floating with minimum copper length (see note in [Clock Outputs](#)), or properly terminated if connected to a transmission line, or disabled/Hi-Z if possible. See [Clock Outputs](#) for output configuration and [Termination and Use of Clock Drivers](#) for output interface and termination techniques.

6 Specifications

6.1 Absolute Maximum Ratings

over operating free-air temperature range (unless otherwise noted)^{(1) (2)}

		MIN	MAX	UNIT
V _{CC} , V _{CCO}	Supply voltages	- 0.3	3.6	V
V _{IN}	Input voltage	- 0.3	(V _{CC} + 0.3)	V
T _L	Lead temperature (solder 4 s)		260	°C
T _J	Junction temperature		150	°C
T _{stg}	Storage temperature	- 65	150	°C

- (1) Stresses beyond those listed under *Absolute Maximum Ratings* may cause permanent damage to the device. These are stress ratings only, which do not imply functional operation of the device at these or any other conditions beyond those indicated under *Recommended Operating Conditions*. Exposure to absolute-maximum-rated conditions for extended periods may affect device reliability.
- (2) If Military/Aerospace specified devices are required, please contact the Texas Instruments Sales Office/Distributors for availability and specifications.

6.2 ESD Ratings

		VALUE	UNIT
V _(ESD)	Electrostatic discharge	Human-body model (HBM), per ANSI/ESDA/JEDEC JS-001 ⁽¹⁾	±2000
		Charged-device model (CDM), per JEDEC specification JESD22-C101 ⁽²⁾	±750
		Machine model (MM)	±150

- (1) JEDEC document JEP155 states that 500-V HBM allows safe manufacturing with a standard ESD control process.
- (2) JEDEC document JEP157 states that 250-V CDM allows safe manufacturing with a standard ESD control process.

6.3 Recommended Operating Conditions

over operating free-air temperature range (unless otherwise noted)

		MIN	TYP	MAX	UNIT	
T _A	Ambient temperature	- 40	25	85	°C	
T _J	Junction temperature			125	°C	
V _{CC}	Core supply voltage	3.15	3.3	3.45	V	
V _{CCO}	Output supply voltage ^{(1) (2)}	3.3-V range	3.3 - 5%	3.3	3.3 + 5%	V
		2.5-V range	2.5 - 5%	2.5	2.5 + 5%	

- (1) The output supply voltages or pins (V_{CCOA}, V_{CCOB}, and V_{CCOC}) will be called V_{CCO} in general when no distinction is needed, or when the output supply can be inferred from the output bank/type.
- (2) V_{CCO} for any output bank should be less than or equal to V_{CC} (V_{CCO} ≤ V_{CC}).

6.4 Thermal Information

THERMAL METRIC ⁽¹⁾		LMK00334 ⁽²⁾	UNIT
		RTV (WQFN)	
		32 PINS	
R _{θJA}	Junction-to-ambient thermal resistance	38.1	°C/W
R _{θJC(top)}	Junction-to-case (top) thermal resistance	7.2	°C/W
R _{θJB}	Junction-to-board thermal resistance	12	°C/W
ψ _{JT}	Junction-to-top characterization parameter	0.4	°C/W
ψ _{JB}	Junction-to-board characterization parameter	11.9	°C/W
R _{θJC(bot)}	Junction-to-case (bottom) thermal resistance	4.5	°C/W

- (1) For more information about traditional and new thermal metrics, see the [Semiconductor and IC Package Thermal Metrics](#) application report.
- (2) Specification assumes 5 thermal vias connect the die attach pad (DAP) to the embedded copper plane on the 4-layer JEDEC board. These vias play a key role in improving the thermal performance of the package. TI recommends using the maximum number of vias in the board layout.

6.5 Electrical Characteristics

Unless otherwise specified: V_{CC} = 3.3 V ± 5%, V_{CCO} = 3.3 V ± 5%, 2.5 V ± 5%, - 40°C ≤ T_A ≤ 85°C, CLKin driven differentially, input slew rate ≥ 3 V/ns. Typical values represent the most likely parametric norms at V_{CC} = 3.3 V, V_{CCO} = 3.3 V, T_A = 25°C, and at the Recommended Operation Conditions at the time of product characterization; because of this, typical values are not ensured. ⁽¹⁾

PARAMETER	TEST CONDITIONS	MIN	TYP	MAX	UNIT	
CURRENT CONSUMPTION ⁽¹⁾						
ICC_CORE	Core supply current, all outputs disabled	CLKinX selected	8.5	10.5	mA	
		OSCin selected	10	13.5	mA	
ICC_HCSL			50	58.5	mA	
ICC_CMOS			3.5	5.5	mA	
ICCO_HCSL	Additive output supply current, HCSL banks enabled	Includes output bank bias and load currents for both banks, R _T = 50 Ω on all outputs		65	81.5	mA
ICCO_CMOS	Additive output supply current, LVCMOS output enabled	200 MHz, C _L = 5 pF	V _{CCO} = 3.3 V ± 5%	9	10	mA
			V _{CCO} = 2.5V ± 5%	7	8	mA

Unless otherwise specified: $V_{CC} = 3.3\text{ V} \pm 5\%$, $V_{CCO} = 3.3\text{ V} \pm 5\%$, $2.5\text{ V} \pm 5\%$, $-40^\circ\text{C} \leq T_A \leq 85^\circ\text{C}$, CLKIn driven differentially, input slew rate $\geq 3\text{ V/ns}$. Typical values represent the most likely parametric norms at $V_{CC} = 3.3\text{ V}$, $V_{CCO} = 3.3\text{ V}$, $T_A = 25^\circ\text{C}$, and at the Recommended Operation Conditions at the time of product characterization; because of this, typical values are not ensured. (1)

PARAMETER		TEST CONDITIONS	MIN	TYP	MAX	UNIT
POWER SUPPLY RIPPLE REJECTION (PSRR)						
PSRR _{HCSL}	Ripple-induced phase spur level ⁽²⁾ Differential HCSL Output	156.25 MHz		- 72		dBc
		312.5 MHz		- 63		
CMOS CONTROL INPUTS (CLKIn_SELn, CLKout_TYPEn, REFout_EN)						
V _{IH}	High-level input voltage		1.6		V _{CC}	V
V _{IL}	Low-level input voltage		GND		0.4	V
I _{IH}	High-level input current	V _{IH} = V _{CC} , internal pulldown resistor			50	μA
I _{IL}	Low-level input current	V _{IL} = 0 V, internal pulldown resistor	- 5	0.1		μA
CLOCK INPUTS (CLKIn0/CLKIn0*, CLKIn1/CLKIn1*)						
f _{CLKIn}	Input frequency range ⁽⁸⁾	Functional up to 400 MHz Output frequency range and timing specified per output type (refer to LVCMOS output specifications)	DC		400	MHz
V _{IHD}	Differential input high voltage				V _{CC}	V
V _{ILD}	Differential input low voltage	CLKIn driven differentially	GND			V
V _{ID}	Differential input voltage swing ⁽³⁾		0.15		1.3	V
V _{CMD}	Differential input CMD common-mode voltage	V _{ID} = 150 mV	0.25		V _{CC} - 1.2	V
		V _{ID} = 350 mV	0.25		V _{CC} - 1.1	
		V _{ID} = 800 mV	0.25		V _{CC} - 0.9	
V _{IH}	Single-ended input IH high voltage				V _{CC}	V
V _{IL}	Single-ended input IL low voltage	CLKInX driven single-ended (AC- or DC-coupled), CLKInX* AC-coupled to GND or externally biased within V _{CM} range	GND			V
V _{I_SE}	Single-ended input voltage swing ⁽⁸⁾		0.3		2	V _{pp}
V _{CM}	Single-ended input CM common-mode voltage		0.25		V _{CC} - 1.2	V
ISO _{MUX}	Mux isolation, CLKIn0 to CLKIn1	f _{OFFSET} > 50 kHz, P _{CLKInX} = 0 dBm	f _{CLKIn0} = 100 MHz		- 84	dBc
			f _{CLKIn0} = 200 MHz		- 82	
			f _{CLKIn0} = 500 MHz		- 71	
			f _{CLKIn0} = 1000 MHz		- 65	
CRYSTAL INTERFACE (OSCIn, OSCout)						
F _{CLK}	External clock frequency range ⁽⁸⁾	OSCIn driven single-ended, OSCout floating			250	MHz
F _{XTAL}	Crystal frequency range	Fundamental mode crystal ESR $\leq 200\ \Omega$ (10 to 30 MHz) ESR $\leq 125\ \Omega$ (30 to 40 MHz) ⁽⁴⁾	10		40	MHz
C _{IN}	OSCIn input capacitance			1		pF

Unless otherwise specified: $V_{CC} = 3.3\text{ V} \pm 5\%$, $V_{CCO} = 3.3\text{ V} \pm 5\%$, $2.5\text{ V} \pm 5\%$, $-40^\circ\text{C} \leq T_A \leq 85^\circ\text{C}$, CLKin driven differentially, input slew rate $\geq 3\text{ V/ns}$. Typical values represent the most likely parametric norms at $V_{CC} = 3.3\text{ V}$, $V_{CCO} = 3.3\text{ V}$, $T_A = 25^\circ\text{C}$, and at the Recommended Operation Conditions at the time of product characterization; because of this, typical values are not ensured. (1)

PARAMETER		TEST CONDITIONS		MIN	TYP	MAX	UNIT
HCSL OUTPUTS (CLKoutAn/CLKoutAn*, CLKoutBn/CLKoutBn*)							
f_{CLKout}	Output frequency range ⁽⁸⁾	$R_L = 50\ \Omega$ to GND, $C_L \leq 5\text{ pF}$		DC		400	MHz
Jitter _{ADD_PClE}	Additive RMS phase jitter for PCIe 5.0 ⁽⁸⁾	PCIe Gen 5 filter	CLKin: 100 MHz, slew rate $\geq 0.5\text{ V/ns}$		0.015	0.03	ps
Jitter _{ADD_PClE}	Additive RMS phase jitter for PCIe 4.0 ⁽⁸⁾	PCIe Gen 4, PLL BW = 2 - 5 MHz, CDR = 10 MHz	CLKin: 100 MHz, slew rate $\geq 1.8\text{ V/ns}$		0.03	0.05	ps
Jitter _{ADD_PClE}	Additive RMS phase jitter for PCIe 3.0 ⁽⁸⁾	PCIe Gen 3, PLL BW = 2 - 5 MHz, CDR = 10 MHz	CLKin: 100 MHz, slew rate $\geq 0.6\text{ V/ns}$		0.03	0.15	ps
Jitter _{ADD}	Additive RMS jitter integration bandwidth 12 MHz to 20 MHz ⁽⁵⁾	$V_{CCO} = 3.3\text{ V}$, $R_T = 50\ \Omega$ to GND	CLKin: 100 MHz, slew rate $\geq 3\text{ V/ns}$		77		fs
Noise Floor	Noise floor $f_{\text{OFFSET}} \geq 10\text{ MHz}$ ^{(6) (7)}	$V_{CCO} = 3.3\text{ V}$, $R_T = 50\ \Omega$ to GND	CLKin: 100 MHz, slew rate $\geq 3\text{ V/ns}$		-161.3		dBc/Hz
DUTY	Duty cycle ⁽⁸⁾	50% input clock duty cycle		45%		55%	
V_{OH}	Output high voltage	$T_A = 25^\circ\text{C}$, DC measurement,		520	810	920	mV
V_{OL}	Output low voltage	$R_T = 50\ \Omega$ to GND		-150	0.5	150	mV
V_{CROSS}	Absolute crossing voltage ^{(8) (9)}	$R_L = 50\ \Omega$ to GND, $C_L \leq 5\text{ pF}$		250	350	460	mV
ΔV_{CROSS}	Total variation of V_{CROSS} ^{(8) (9)}					140	mV
t_R	Output rise time 20% to 80% ^{(9) (12)}	250 MHz, uniform transmission line up to 10 in. with 50- Ω characteristic impedance, $R_L = 50\ \Omega$ to GND, $C_L \leq 5\text{ pF}$			225	400	ps
t_F	Output fall time 80% to 20% ^{(9) (12)}				225	400	ps
LVC MOS OUTPUT (REFout)							
f_{CLKout}	Output frequency range ⁽⁸⁾	$C_L \leq 5\text{ pF}$		DC		250	MHz
Jitter _{ADD}	Additive RMS jitter integration bandwidth 1 MHz to 20 MHz ⁽⁵⁾	$V_{CCO} = 3.3\text{ V}$, $C_L \leq 5\text{ pF}$	100 MHz, input slew rate $\geq 3\text{ V/ns}$		95		fs
Noise Floor	Noise floor $f_{\text{OFFSET}} \geq 10\text{ MHz}$ ^{(6) (7)}	$V_{CCO} = 3.3\text{ V}$, $C_L \leq 5\text{ pF}$	100 MHz, input slew rate $\geq 3\text{ V/ns}$		-159.3		dBc/Hz
DUTY	Duty cycle ⁽⁸⁾	50% input clock duty cycle		45%		55%	
V_{OH}	Output high voltage	1-mA load		V_{CCO} - 0.1			V
V_{OL}	Output low voltage					0.1	V
I_{OH}	Output high current (source)			$V_{CCO} = 3.3\text{ V}$	28		mA
I_{OL}	Output low current (sink)	$V_O = V_{CCO} / 2$		$V_{CCO} = 2.5\text{ V}$	20		
				$V_{CCO} = 3.3\text{ V}$	28		mA
				$V_{CCO} = 2.5\text{ V}$	20		
t_R	Output rise time 20% to 80% ^{(9) (12)}	250 MHz, uniform transmission line up to 10 in. with 50- Ω characteristic impedance, $R_L = 50\ \Omega$ to GND, $C_L \leq 5\text{ pF}$			225	400	ps
t_F	Output fall time 80% to 20% ^{(10) (12)}				225	400	ps
t_{EN}	Output enable time ⁽¹⁰⁾					3	cycles
t_{DIS}	Output disable time ⁽¹⁰⁾	$C_L \leq 5\text{ pF}$				3	cycles

- See [Power Supply Recommendations](#) and [Thermal Management](#) for more information on current consumption and power dissipation calculations.
- Power supply ripple rejection, or PSRR, is defined as the single-sideband phase spur level (in dBc) modulated onto the clock output when a single-tone sinusoidal signal (ripple) is injected onto the V_{CCO} supply. Assuming no amplitude modulation effects and small index modulation, the peak-to-peak deterministic jitter (DJ) can be calculated using the measured single-sideband phase spur level (PSRR) as follows: $\text{DJ (ps pk-pk)} = [(2 \times 10^{(\text{PSRR} / 20)}) / (\pi \times f_{\text{CLK}})] \times 1\text{E}12$
- See [Differential Voltage Measurement Terminology](#) for definition of V_{ID} and V_{OD} voltages.

- (4) The ESR requirements stated must be met to ensure that the oscillator circuitry has no start-up issues. However, lower ESR values for the crystal may be necessary to stay below the maximum power dissipation (drive level) specification of the crystal. Refer to [Crystal Interface](#) for crystal drive level considerations.
- (5) For the 100-MHz and 156.25-MHz clock input conditions, Additive RMS Jitter (J_{ADD}) is calculated using Method #1: $J_{ADD} = \text{SQRT}(J_{OUT}^2 - J_{SOURCE}^2)$, where J_{OUT} is the total RMS jitter measured at the output driver and J_{SOURCE} is the RMS jitter of the clock source applied to CLKIn. For the 625-MHz clock input condition, Additive RMS Jitter is approximated using Method #2: $J_{ADD} = \text{SQRT}(2 \times 10^{\text{dBc}/10}) / (2 \times \pi \times f_{CLK})$, where dBc is the phase noise power of the Output Noise Floor integrated from 12-kHz to 20-MHz bandwidth. The phase noise power can be calculated as: $\text{dBc} = \text{Noise Floor} + 10 \times \log_{10}(20 \text{ MHz} - 12 \text{ kHz})$.
- (6) The noise floor of the output buffer is measured as the far-out phase noise of the buffer. Typically this offset is ≥ 10 MHz, but for lower frequencies this measurement offset can be as low as 5 MHz due to measurement equipment limitations.
- (7) Phase noise floor will degrade as the clock input slew rate is reduced. Compared to a single-ended clock, a differential clock input (LVPECL, LVDS) will be less susceptible to degradation in noise floor at lower slew rates due to its common-mode noise rejection. However, TI recommends using the highest possible input slew rate for differential clocks to achieve optimal noise floor performance at the device outputs.
- (8) Specification is ensured by characterization and is not tested in production.
- (9) AC timing parameters for HCSL or CMOS are dependent on output capacitive loading.
- (10) Output Enable Time is the number of input clock cycles it takes for the output to be enabled after REFout_EN is pulled high. Similarly, Output Disable Time is the number of input clock cycles it takes for the output to be disabled after REFout_EN is pulled low. The REFout_EN signal should have an edge transition much faster than that of the input clock period for accurate measurement.
- (11) Output skew is the propagation delay difference between any two outputs with identical output buffer type and equal loading while operating at the same supply voltage and temperature conditions.
- (12) Parameter is specified by design, not tested in production.

6.6 Timing Requirements, Propagation Delay, and Output Skew

			MIN	TYP	MAX	UNIT	
t_{PD_HCSL}	Propagation delay CLKIn-to-HCSL ^{(1) (2)}	$R_T = 50 \Omega$ to GND, $C_L \leq 5 \text{ pF}$	295	590	885	ps	
t_{PD_CMOS}	Propagation delay CLKIn-to-LVCMOS ^{(1) (2)}	$C_L \leq 5 \text{ pF}$	$V_{CCO} = 3.3 \text{ V}$	900	1475	2300	ps
			$V_{CCO} = 2.5 \text{ V}$	1000	1550	2700	
$t_{SK(O)}$	Output skew ^{(11) (9) (4)}	Skew specified between any two CLKouts.		30	50	ps	
$t_{SK(PP)}$	Part-to-part output skew ^{(1) (2) (3)}	Load conditions are the same as propagation delay specifications.		80	120	ps	

- (1) AC timing parameters for HCSL or CMOS are dependent on output capacitive loading.
- (2) Parameter is specified by design, not tested in production.
- (3) Output skew is the propagation delay difference between any two outputs with identical output buffer type and equal loading while operating at the same supply voltage and temperature conditions.
- (4) Specification is ensured by characterization and is not tested in production.

6.7 Typical Characteristics

Unless otherwise specified: $V_{CC} = 3.3\text{ V}$, $V_{CC0} = 3.3\text{ V}$, $T_A = 25^\circ\text{C}$, CLKin driven differentially, input slew rate $\geq 3\text{ V/ns}$.



图 6-1. HCSL Output Swing at 250 MHz



图 6-2. LVCMOS Output Swing at 250 MHz

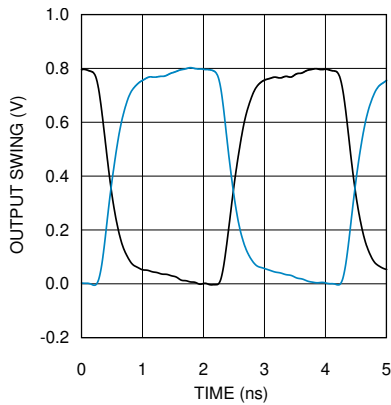

图 6-3. Noise Floor vs. CLKin Slew Rate at 100 MHz

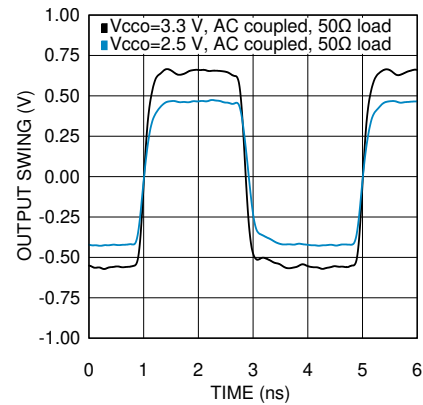

图 6-4. Noise Floor vs. CLKin Slew Rate at 156.25 MHz

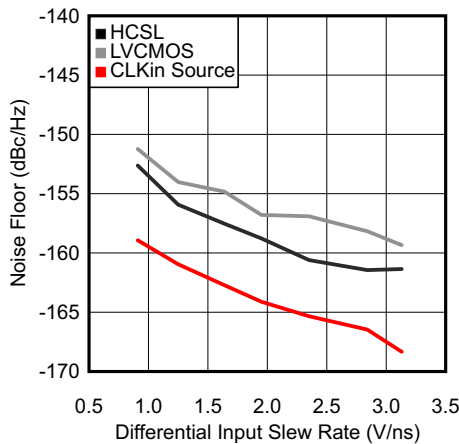

图 6-5. RMS Jitter vs. CLKin Slew Rate at 100 MHz

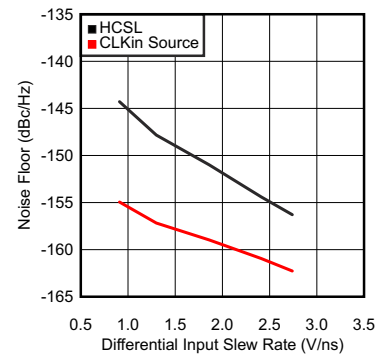

图 6-6. RMS Jitter vs. CLKin Slew Rate at 156.25 MHz

6.7 Typical Characteristics (continued)

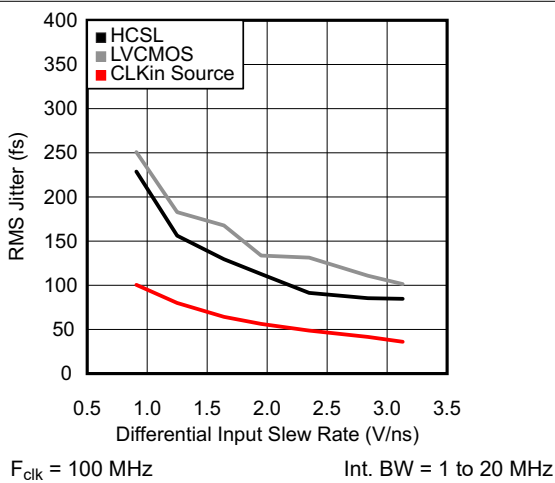
Unless otherwise specified: $V_{CC} = 3.3\text{ V}$, $V_{CC0} = 3.3\text{ V}$, $T_A = 25^\circ\text{C}$, CLKin driven differentially, input slew rate $\geq 3\text{ V/ns}$.

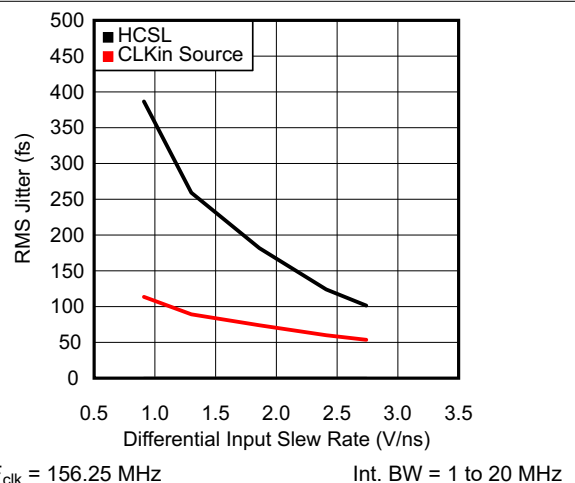

图 6-7. PSRR vs. Ripple Frequency at 156.25 MHz



图 6-8. PSRR vs. Ripple Frequency at 312.5 MHz

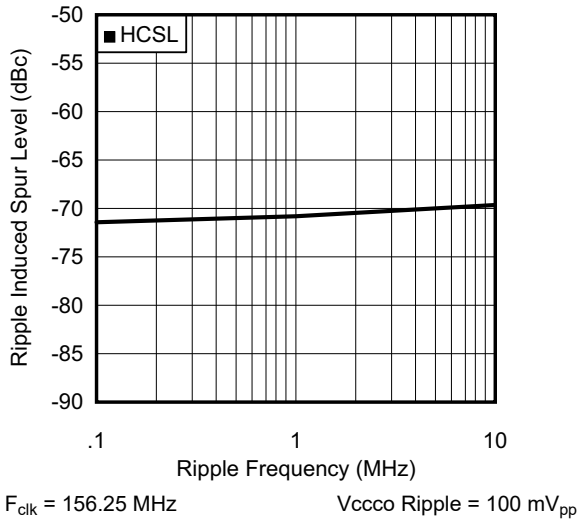

图 6-9. Propagation Delay vs. Temperature

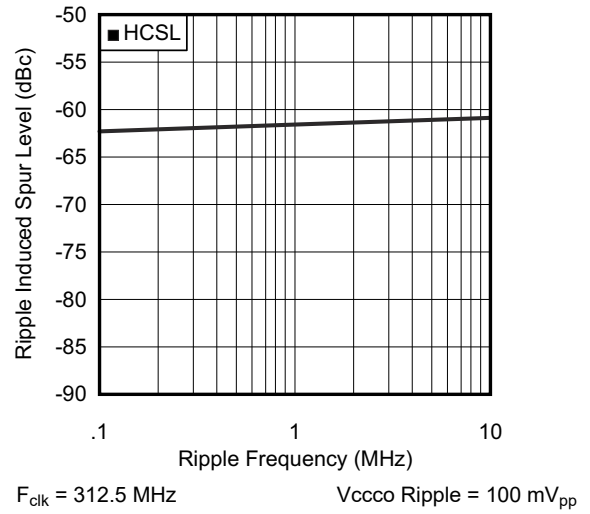

图 6-10. Crystal Power Dissipation vs. R_{LIM}

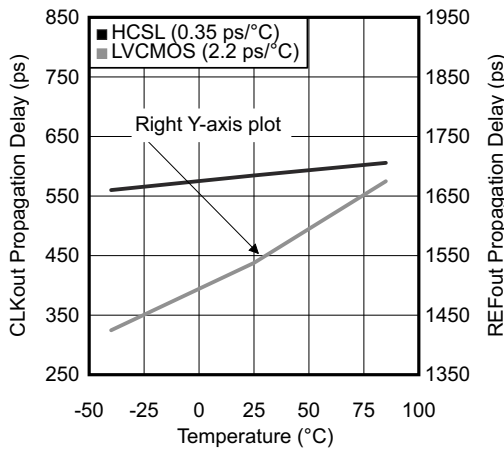

图 6-11. HCSL Phase Noise at 100 MHz

7 Parameter Measurement Information

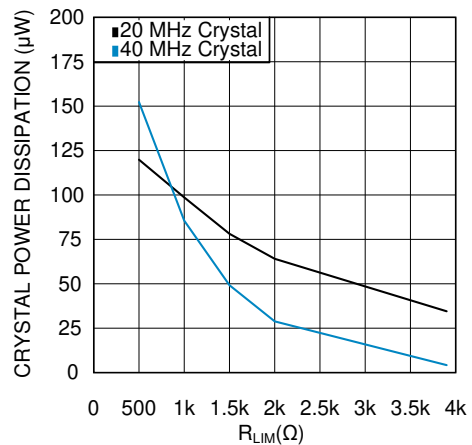
7.1 Differential Voltage Measurement Terminology

The differential voltage of a differential signal can be described by two different definitions, causing confusion when reading data sheets or communicating with other engineers. This section will address the measurement and description of a differential signal so that the reader will be able to understand and discern between the two different definitions when used.

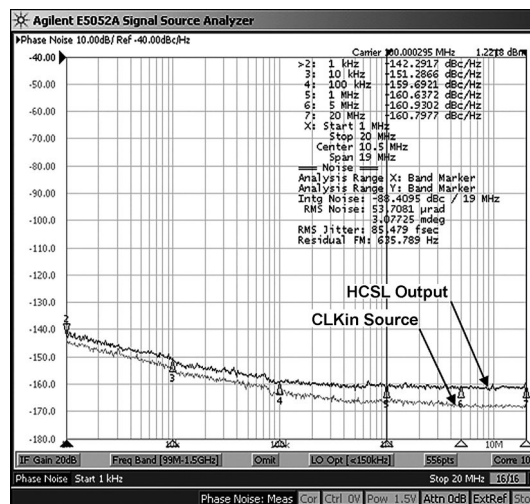
The first definition used to describe a differential signal is the absolute value of the voltage potential between the inverting and noninverting signal. The symbol for this first measurement is typically V_{ID} or V_{OD} depending on if an input or output voltage is being described.

The second definition used to describe a differential signal is to measure the potential of the noninverting signal with respect to the inverting signal. The symbol for this second measurement is V_{SS} and is a calculated parameter. Nowhere in the IC does this signal exist with respect to ground; it only exists in reference to its differential pair. V_{SS} can be measured directly by oscilloscopes with floating references, otherwise this value can be calculated as twice the value of V_{OD} as described in the first description.

图 7-1 illustrates the two different definitions side-by-side for inputs and 图 7-2 illustrates the two different definitions side-by-side for outputs. The V_{ID} (or V_{OD}) definition show the DC levels, V_{IH} and V_{OL} (or V_{OH} and V_{OL}), that the noninverting and inverting signals toggle between with respect to ground. V_{SS} input and output definitions show that if the inverting signal is considered the voltage potential reference, the noninverting signal voltage potential is now increasing and decreasing above and below the noninverting reference. Thus the peak-to-peak voltage of the differential signal can be measured.

V_{ID} and V_{OD} are often defined as volts (V) and V_{SS} is often defined as volts peak-to-peak (V_{PP}).



图 7-1. Two Different Definitions for Differential Input Signals



图 7-2. Two Different Definitions for Differential Output Signals

Refer to [Common Data Transmission Parameters and their Definitions](#) (SNLA036) for more information.

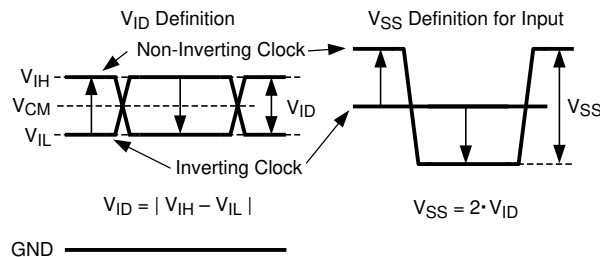
8 Detailed Description

8.1 Overview

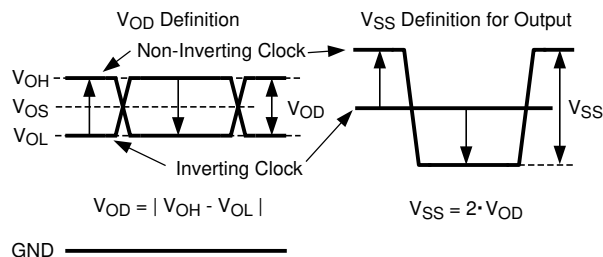
The LMK00334 is a 4-output HCSL clock fanout buffer with low additive jitter that can operate up to 400 MHz. It features a 3:1 input multiplexer with an optional crystal oscillator input, two banks of two HCSL outputs, one LVCMOS output, and three independent output buffer supplies. The input selection and output buffer modes are controlled through pin strapping. The device is offered in a 32-pin WQFN package and leverages much of the high-speed, low-noise circuit design employed in the LMK04800 family of clock conditioners.

8.2 Functional Block Diagram

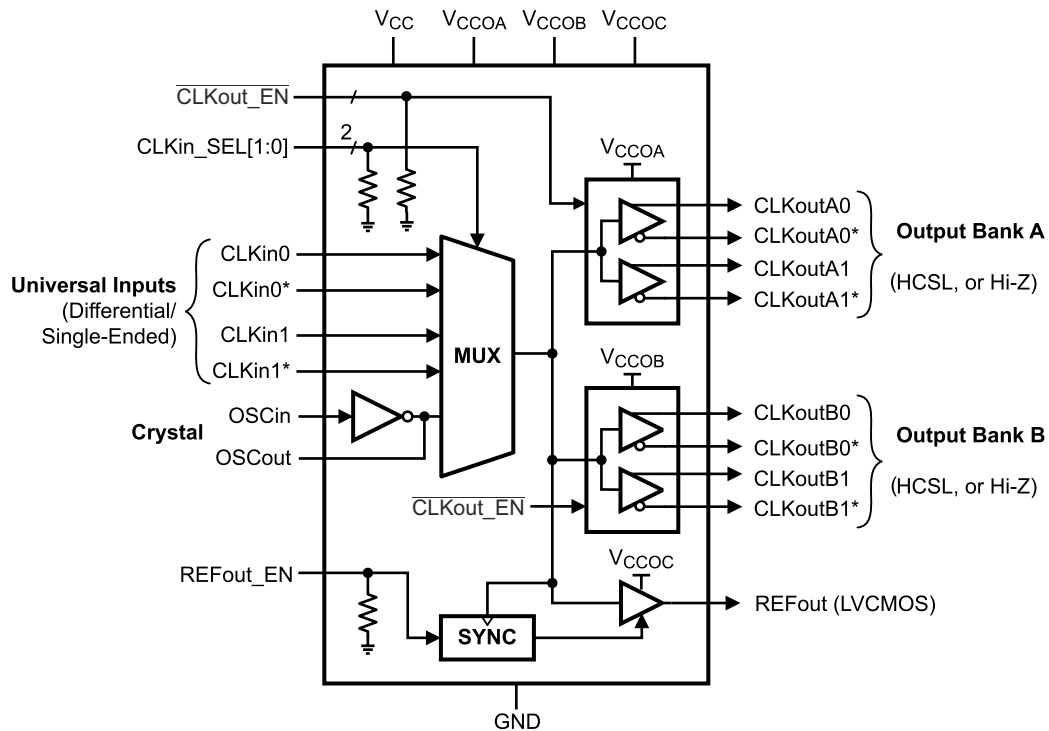

8.3 Feature Description

8.3.1 Crystal Power Dissipation vs. R_{LIM}

For [Figure 6-10](#), the following applies:

- The typical RMS jitter values in the plots show the total output RMS jitter (J_{OUT}) for each output buffer type and the source clock RMS jitter (J_{SOURCE}). From these values, the Additive RMS Jitter can be calculated as: $J_{ADD} = \text{SQRT}(J_{OUT}^2 - J_{SOURCE}^2)$.
- 20-MHz crystal characteristics: Abracon ABL series, AT cut, $C_L = 18$ pF, $C_0 = 4.4$ pF measured (7 pF maximum), ESR = 8.5 Ω measured (40 Ω maximum), and Drive Level = 1 mW maximum (100 μ W typical).
- 40-MHz crystal characteristics: Abracon ABLS2 series, AT cut, $C_L = 18$ pF, $C_0 = 5$ pF measured (7 pF maximum), ESR = 5 Ω measured (40 Ω maximum), and Drive Level = 1 mW maximum (100 μ W typical).

8.3.2 Clock Inputs

The input clock can be selected from CLKin0/CLKin0*, CLKin1/CLKin1*, or OSCin. Clock input selection is controlled using the CLKin_SEL[1:0] inputs as shown in [表 8-1](#). Refer to [Driving the Clock Inputs](#) for clock input requirements. When CLKin0 or CLKin1 is selected, the crystal circuit is powered down. When OSCin is selected, the crystal oscillator circuit will start up and its clock will be distributed to all outputs. Refer to [Crystal Interface](#) for more information. Alternatively, OSCin may be driven by a single-ended clock (up to 250 MHz) instead of a crystal.

表 8-1. Input Selection

CLKin_SEL1	CLKin_SEL0	SELECTED INPUT
0	0	CLKin0, CLKin0*
0	1	CLKin1, CLKin1*
1	X	OSCin

[表 8-2](#) shows the output logic state vs. input state when either CLKin0/CLKin0* or CLKin1/CLKin1* is selected. When OSCin is selected, the output state will be an inverted copy of the OSCin input state.

表 8-2. CLKin Input vs. Output States

STATE OF SELECTED CLKin	STATE OF ENABLED OUTPUTS
CLKinX and CLKinX* inputs floating	Logic low
CLKinX and CLKinX* inputs shorted together	Logic low
CLKin logic low	Logic low
CLKin logic high	Logic high

8.3.3 Clock Outputs

The HCSL output buffer for both Bank A and B outputs can be disabled to Hi-Z using the $\overline{\text{CLKout_EN}}$ [1:0] as shown in [表 8-3](#). For applications where all differential outputs are not needed, any unused output pin should be left floating with a minimum copper length (see note below) to minimize capacitance and potential coupling and reduce power consumption. If all differential outputs are not used, TI recommends disabling (Hi-Z) the banks to reduce power. Refer to [Termination and Use of Clock Drivers](#) for more information on output interface and termination techniques.

Note

For best soldering practices, the minimum trace length for any unused pin should extend to include the pin solder mask. This way during reflow, the solder has the same copper area as connected pins. This allows for good, uniform fillet solder joints helping to keep the IC level during reflow.

表 8-3. Differential Output Buffer Type Selection

CLKout_EN	CLKoutX BUFFER TYPE (BANK A AND B)
0	HCSL
1	Disabled (Hi-Z)

8.3.3.1 Reference Output

The reference output (REFout) provides a LVCMOS copy of the selected input clock. The LVCMOS output high level is referenced to the V_{CCO} voltage. REFout can be enabled or disabled using the enable input pin, REFout_EN, as shown in [表 8-4](#).

表 8-4. Reference Output Enable

REFout_EN	REFout STATE
0	Disabled (Hi-Z)
1	Enabled

The REFout_EN input is internally synchronized with the selected input clock by the SYNC block. This synchronizing function prevents glitches and runt pulses from occurring on the REFout clock when enabled or disabled. REFout will be enabled within three cycles (t_{EN}) of the input clock after REFout_EN is toggled high. REFout will be disabled within three cycles (t_{DIS}) of the input clock after REFout_EN is toggled low.

When REFout is disabled, the use of a resistive loading can be used to set the output to a predetermined level. For example, if REFout is configured with a 1-k Ω load to ground, then the output will be pulled to low when disabled.

8.4 Device Functional Modes

8.4.1 V_{CC} and V_{CCO} Power Supplies

The LMK00334 has separate 3.3-V core supplies (V_{CC}) and three independent 3.3-V or 2.5-V output power supplies (V_{CCOA} , V_{CCOB} , V_{CCOC}). Output supply operation at 2.5 V enables lower power consumption and output-level compatibility with 2.5-V receiver devices. The output levels for HCSL are relatively constant over the specified V_{CCO} range. Refer to [Power Supply Recommendations](#) for additional supply related considerations, such as power dissipation, power supply bypassing, and power supply ripple rejection (PSRR).

Note

Take care to ensure the V_{CCO} voltages do not exceed the V_{CC} voltage to prevent turning-on the internal ESD protection circuitry.

9 Application and Implementation

Note

以下应用部分中的信息不属于 TI 器件规格的范围，TI 不担保其准确性和完整性。TI 的客户应负责确定器件是否适用于其应用。客户应验证并测试其设计，以确保系统功能。

9.1 Application Information

A common PCIe application, such as a server card, consists of several building blocks, which all need a reference clock. In the mostly used Common RefClk architecture, the clock is distributed from a single source to both RX and TX. This requires either a Clock generator with high output count or a buffer like the LMK00334. The buffer simplifies the clocking tree and provides a cost and space optimized solution. While using a buffer to distribute the clock, the additive jitter must be considered. The LMK00334 is an ultra-low additive jitter PCIe clock buffer suitable for all current and future PCIe Generations.

9.2 Typical Application



图 9-1. Example PCI Express Application

9.2.1 Design Requirements

9.2.1.1 Driving the Clock Inputs

The LMK00334 has two universal inputs (CLKin0/CLKin0* and CLKin1/CLKin1*) that can accept DC-coupled, 3.3-V or 2.5-V LVPECL, LVDS, CML, SSTL, and other differential and single-ended signals that meet the input requirements specified in [Electrical Characteristics](#). The device can accept a wide range of signals due to its wide input common-mode voltage range (V_{CM}) and input voltage swing (V_{ID}) / dynamic range. For 50% duty cycle and DC-balanced signals, AC coupling may also be employed to shift the input signal to within the V_{CM} range. Refer to [Termination and Use of Clock Drivers](#) for signal interfacing and termination techniques.

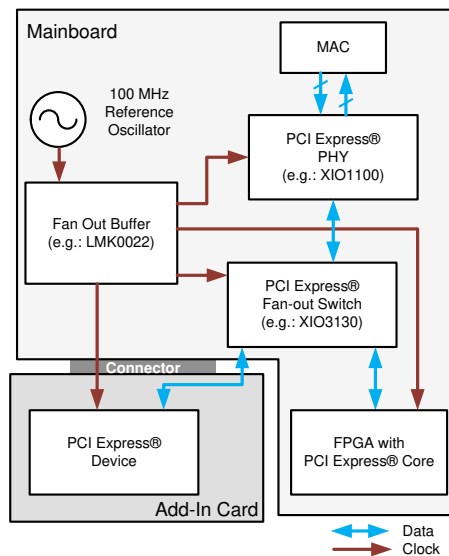
To achieve the best possible phase noise and jitter performance, it is mandatory for the input to have high slew rate of 3 V/ns (differential) or higher. Driving the input with a lower slew rate will degrade the noise floor and jitter. For this reason, a differential signal input is recommended over single-ended because it typically provides higher slew rate and common-mode rejection. Refer to the *Noise Floor vs. CLKin Slew Rate* and *RMS Jitter vs. CLKin Slew Rate* plots in [Typical Characteristics](#).

While TI recommends driving the CLKin/CLKin* pair with a differential signal input, it is possible to drive it with a single-ended clock provided it conforms to the single-ended input specifications for CLKin pins listed in the [Electrical Characteristics](#). For large single-ended input signals, such as 3.3-V or 2.5-V LVCMOS, a 50- Ω load resistor should be placed near the input for signal attenuation to prevent input overdrive as well as for line termination to minimize reflections. Again, the single-ended input slew rate should be as high as possible to minimize performance degradation. The CLKin input has an internal bias voltage of about 1.4 V, so the input can be AC coupled as shown in [Figure 9-2](#). The output impedance of the LVCMOS driver plus R_s should be close to 50 Ω to match the characteristic impedance of the transmission line and load termination.



图 9-2. Single-Ended LVCMOS Input, AC Coupling

A single-ended clock may also be DC-coupled to CLKinX as shown in [Figure 9-3](#). A 50- Ω load resistor should be placed near the CLKin input for signal attenuation and line termination. Because half of the single-ended swing of the driver ($V_{O,PP} / 2$) drives CLKinX, CLKinX* should be externally biased to the midpoint voltage of the attenuated input swing ($(V_{O,PP} / 2) \times 0.5$). The external bias voltage should be within the specified input common mode voltage (V_{CM}) range. This can be achieved using external biasing resistors in the $k\Omega$ range (R_{B1} and R_{B2}) or another low-noise voltage reference. This will ensure the input swing crosses the threshold voltage at a point where the input slew rate is the highest.

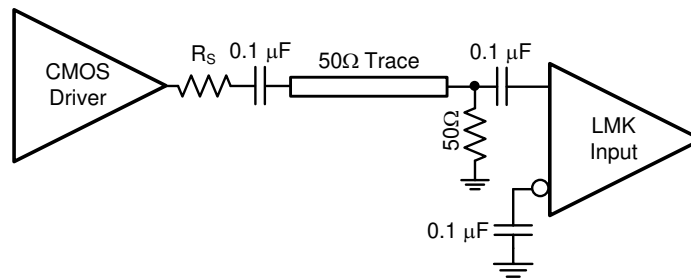

图 9-3. Single-Ended LVCMOS Input, DC Coupling With Common-Mode Biasing

If the crystal oscillator circuit is not used, it is possible to drive the OSCin input with a single-ended external clock as shown in 图 9-4. The input clock should be AC coupled to the OSCin pin, which has an internally-generated input bias voltage, and the OSCout pin should be left floating. While OSCin provides an alternative input to multiplex an external clock, TI recommends using either universal input (CLKinX) because it offers higher operating frequency, better common-mode and power supply noise rejection, and greater performance over supply voltage and temperature variations.

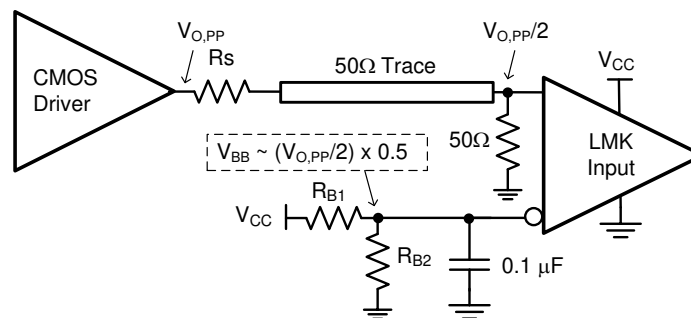

图 9-4. Driving OSCin With a Single-Ended Input

9.2.1.2 Crystal Interface

The LMK00334 has an integrated crystal oscillator circuit that supports a fundamental mode, AT-cut crystal. The crystal interface is shown in 图 9-5.

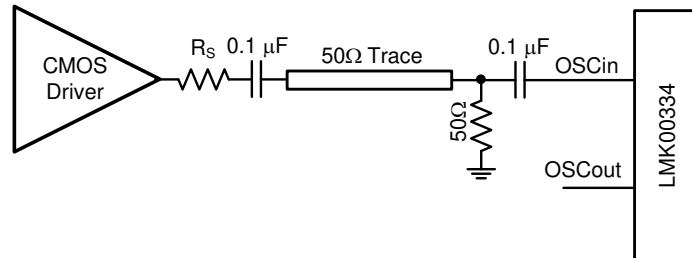

图 9-5. Crystal Interface

The load capacitance (C_L) is specific to the crystal, but usually on the order of 18 to 20 pF. While C_L is specified for the crystal, the OSCin input capacitance ($C_{IN} = 1$ pF typical) of the device and PCB stray capacitance (C_{STRAY} is approximately around 1 to 3 pF) can affect the discrete load capacitor values, C_1 and C_2 .

For the parallel resonant circuit, the discrete capacitor values can be calculated as follows:

$$C_L = (C_1 \times C_2) / (C_1 + C_2) + C_{IN} + C_{STRAY} \quad (1)$$

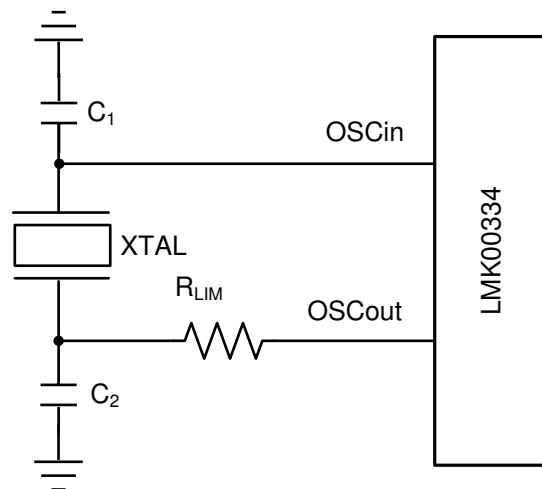
Typically, $C_1 = C_2$ for optimum symmetry, so 方程式 1 can be rewritten in terms of C_1 only:

$$C_L = C_1^2 / (2 \times C_1) + C_{IN} + C_{STRAY} \quad (2)$$

Finally, solve for C_1 :

$$C_1 = (C_L - C_{IN} - C_{STRAY}) \times 2 \quad (3)$$

Electrical Characteristics provides crystal interface specifications with conditions that ensure start-up of the crystal, but it does not specify crystal power dissipation. The designer must ensure the crystal power dissipation does not exceed the maximum drive level specified by the crystal manufacturer. Overdriving the crystal can cause premature aging, frequency shift, and eventual failure. Drive level should be held at a sufficient level necessary to start up and maintain steady-state operation.

The power dissipated in the crystal, P_{XTAL} , can be computed by:

$$P_{XTAL} = I_{RMS}^2 \times R_{ESR} \times (1 + C_0/C_L)^2 \quad (4)$$

where

- I_{RMS} is the RMS current through the crystal.
- R_{ESR} is the maximum equivalent series resistance specified for the crystal
- C_L is the load capacitance specified for the crystal
- C_0 is the minimum shunt capacitance specified for the crystal

I_{RMS} can be measured using a current probe (Tektronix CT-6 or equivalent, for example) placed on the leg of the crystal connected to OSCout with the oscillation circuit active.

As shown in [Figure 9-5](#), an external resistor, R_{LIM} , can be used to limit the crystal drive level, if necessary. If the power dissipated in the selected crystal is higher than the drive level specified for the crystal with R_{LIM} shorted, then a larger resistor value is mandatory to avoid overdriving the crystal. However, if the power dissipated in the crystal is less than the drive level with R_{LIM} shorted, then a zero value for R_{LIM} can be used. As a starting point, a suggested value for R_{LIM} is 1.5 k Ω .

9.2.2 Detailed Design Procedure

9.2.2.1 Termination and Use of Clock Drivers

When terminating clock drivers, keep these guidelines in mind for optimum phase noise and jitter performance:

- Transmission line theory should be followed for good impedance matching to prevent reflections.
- Clock drivers should be presented with the proper loads.
 - HCSL drivers are switched current outputs and require a DC path to ground through 50- Ω termination.
- Receivers should be presented with a signal biased to their specified DC bias level (common-mode voltage) for proper operation. Some receivers have self-biasing inputs that automatically bias to the proper voltage level; in this case, the signal should normally be AC coupled.

9.2.2.2 Termination for DC-Coupled Differential Operation

For DC-coupled operation of an HCSL driver, terminate with 50 Ω to ground near the driver output as shown in [Figure 9-6](#). Series resistors, R_s , may be used to limit overshoot due to the fast transient current. Because HCSL drivers require a DC path to ground, AC coupling is not allowed between the output drivers and the 50- Ω termination resistors.

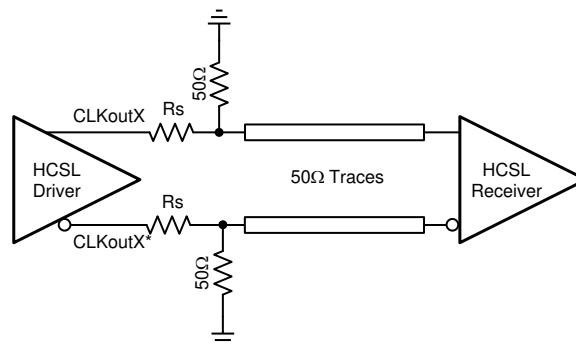
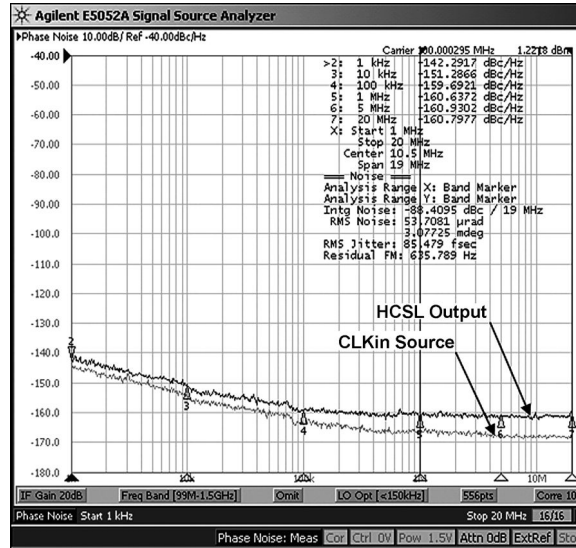

Figure 9-6. HCSL Operation, DC Coupling

9.2.2.3 Termination for AC-Coupled Differential Operation

AC coupling allows for shifting the DC bias level (common-mode voltage) when driving different receiver standards. Because AC-coupling prevents the driver from providing a DC bias voltage at the receiver, it is important to ensure the receiver is biased to its ideal DC level.

9.2.3 Application Curve



9-7. HCSL Phase Noise at 100 MHz

10 Power Supply Recommendations

10.1 Current Consumption and Power Dissipation Calculations

The current consumption values specified in *Electrical Characteristics* can be used to calculate the total power dissipation and IC power dissipation for any device configuration. The total V_{CC} core supply current (I_{CC_TOTAL}) can be calculated using [方程式 5](#):

$$I_{CC_TOTAL} = I_{CC_CORE} + I_{CC_BANKS} + I_{CC_CMOS} \quad (5)$$

where

- I_{CC_CORE} is the V_{CC} current for core logic and input blocks and depends on selected input (CLKinX or OSCin).
- I_{CC_HCSL} is the V_{CC} current for Banks A and B
- I_{CC_CMOS} is the V_{CC} current for the LVCMOS output (or 0 mA if REFout is disabled).

Because the output supplies (V_{CCOA} , V_{CCOB} , V_{CCOC}) can be powered from three independent voltages, the respective output supply currents ($I_{CCO_BANK_A}$, $I_{CCO_BANK_B}$, and I_{CCO_CMOS}) should be calculated separately.

I_{CCO_BANK} for either Bank A or B may be taken as 50% of the corresponding output supply current specified for two banks (I_{CCO_HCSL}) **provided the output loading matches the specified conditions**. Otherwise, I_{CCO_BANK} should be calculated per bank as shown in [方程式 6](#):

$$I_{CCO_BANK} = I_{BANK_BIAS} + (N \times I_{OUT_LOAD}) \quad (6)$$

where

- I_{BANK_BIAS} is the output bank bias current (fixed value).
- I_{OUT_LOAD} is the DC load current per loaded output pair.
- N is the number of loaded output pairs (N = 0 to 2).

[表 10-1](#) shows the typical I_{BANK_BIAS} values and I_{OUT_LOAD} expressions for HCSL.

表 10-1. Typical Output Bank Bias and Load Currents

CURRENT PARAMETER	HCSL
I_{BANK_BIAS}	2.4 mA
I_{OUT_LOAD}	V_{OH}/R_T

Once the current consumption is known for each supply, the total power dissipation (P_{TOTAL}) can be calculated by [方程式 7](#):

$$P_{TOTAL} = (V_{CC} \times I_{CC_TOTAL}) + (V_{CCOA} \times I_{CCO_BANK}) + (V_{CCOB} \times I_{CCO_BANK}) + (V_{CCOC} \times I_{CCO_CMOS}) \quad (7)$$

If the device is configured with HCSL outputs, then it is also necessary to calculate the power dissipated in any termination resistors (P_{RT_HCSL}). The external power dissipation values can be calculated by [方程式 8](#):

$$P_{RT_HCSL} \text{ (per HCSL pair)} = V_{OH}^2 / R_T \quad (8)$$

Finally, the IC power dissipation (P_{DEVICE}) can be computed by subtracting the external power dissipation values from P_{TOTAL} as shown in [方程式 9](#):

$$P_{DEVICE} = P_{TOTAL} - N \times P_{RT_HCSL} \quad (9)$$

where

- N is the number of HCSL output pairs with termination resistors to GND.

10.1.1 Power Dissipation Example: Worst-Case Dissipation

This example shows how to calculate IC power dissipation for a configuration to estimate **worst-case power dissipation**. In this case, the maximum supply voltage and supply current values specified in [Electrical Characteristics](#) are used:

- Max $V_{CC} = V_{CCO} = 3.465$ V. Max I_{CC} and I_{CCO} values.
- CLKin0/CLKin0* input is selected.
- Banks A and B are enabled, and all outputs are terminated with $50\ \Omega$ to GND.
- REFout is enabled with 5-pF load.
- $T_A = 85^\circ\text{C}$

Using the power calculations from the previous section and *maximum* supply current specifications, the user can compute P_{TOTAL} and P_{DEVICE} .

- From [方程式 5](#): $I_{CC_TOTAL} = 10.5\ \text{mA} + 58.5\ \text{mA} + 5.5\ \text{mA} = 74.5\ \text{mA}$
- From I_{CCO_HCSL} max spec: $I_{CCO_BANK} = 50\%$ of $I_{CCO_HCSL} = 40.75\ \text{mA}$
- From [方程式 7](#): $P_{TOTAL} = (3.465\ \text{V} \times 74.5\ \text{mA}) + (3.465\ \text{V} \times 40.75\ \text{mA}) + (3.465\ \text{V} \times 40.75\ \text{mA}) + (3.465\ \text{V} \times 10\ \text{mA}) = 575.2\ \text{mW}$
- From [方程式 8](#): $P_{RT_HCSL} = (0.92\ \text{V})^2 / 50\ \Omega = 16.9\ \text{mW}$ (per output pair)
- From [方程式 9](#): $P_{DEVICE} = 575.2\ \text{mW} - (4 \times 16.9\ \text{mW}) = 510.4\ \text{mW}$

In this worst-case example, the IC device will dissipate about 510.4 mW or 88.7% of the total power (575.2 mW), while the remaining 11.3% will be dissipated in the termination resistors (64.8 mW for 4 pairs). Based on $R_{\theta JA}$ of 38.1°C/W , the estimate die junction temperature would be about 19.4°C above ambient, or 104.4°C when $T_A = 85^\circ\text{C}$.

10.2 Power Supply Bypassing

The V_{CC} and V_{CCO} power supplies should have a high-frequency bypass capacitor, such as 0.1 μF or 0.01 μF , placed very close to each supply pin. 1- μF to 10- μF decoupling capacitors should also be placed nearby the device between the supply and ground planes. All bypass and decoupling capacitors should have short connections to the supply and ground plane through a short trace or via to minimize series inductance.

10.2.1 Power Supply Ripple Rejection

In practical system applications, power supply noise (ripple) can be generated from switching power supplies, digital ASICs or FPGAs, and so forth. While power supply bypassing will help filter out some of this noise, it is important to understand the effect of power supply ripple on the device performance. When a single-tone sinusoidal signal is applied to the power supply of a clock distribution device, such as LMK00334, it can produce narrow-band phase modulation as well as amplitude modulation on the clock output (carrier). In the single-side band phase noise spectrum, the ripple-induced phase modulation appears as a phase spur level relative to the carrier (measured in dBc).

For the LMK00334, power supply ripple rejection, or PSRR, was measured as the single-sideband phase spur level (in dBc) modulated onto the clock output when a ripple signal was injected onto the V_{CCO} supply. The PSRR test setup is shown in [Figure 10-1](#).



图 10-1. PSRR Test Setup

A signal generator was used to inject a sinusoidal signal onto the V_{CCO} supply of the DUT board, and the peak-to-peak ripple amplitude was measured at the V_{CCO} pins of the device. A limiting amplifier was used to remove amplitude modulation on the differential output clock and convert it to a single-ended signal for the phase noise analyzer. The phase spur level measurements were taken for clock frequencies of 156.25 MHz and 312.5 MHz under the following power supply ripple conditions:

- Ripple amplitude: 100 mVpp on $V_{CCO} = 2.5\text{ V}$
- Ripple frequencies: 100 kHz, 1 MHz, and 10 MHz

Assuming no amplitude modulation effects and small index modulation, the peak-to-peak deterministic jitter (DJ) can be calculated using the measured single-sideband phase spur level (PSRR) as follows:

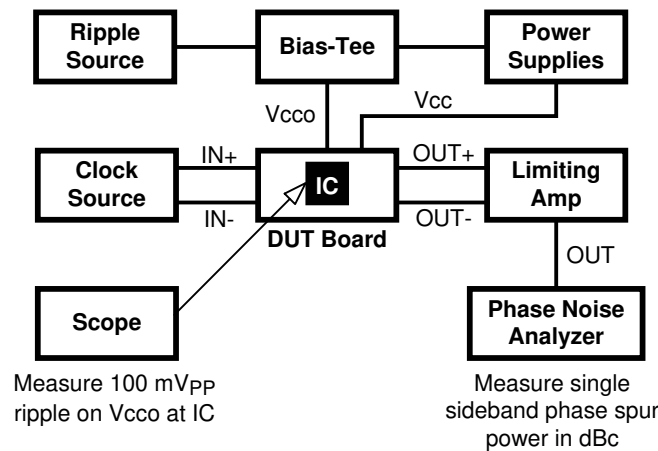
$$\text{DJ (ps pk-pk)} = [(2 \times 10^{(\text{PSRR} / 20)}) / (\pi \times f_{\text{CLK}})] \times 10^{12} \quad (10)$$

The *PSRR vs. Ripple Frequency* plots in [Typical Characteristics](#) show the ripple-induced phase spur levels at 156.25 MHz and 312.5 MHz. The LMK00334 exhibits very good and well-behaved PSRR characteristics across the ripple frequency range. The phase spur levels for HCSL are below -72 dBc at 156.25 MHz and below -63 dBc at 312.5 MHz. Using [Equation 10](#), these phase spur levels translate to Deterministic Jitter values of 1.02 ps pk-pk at 156.25 MHz and 1.44 ps pk-pk at 312.5 MHz. Testing has shown that the PSRR performance of the device improves for $V_{CCO} = 3.3\text{ V}$ under the same ripple amplitude and frequency conditions.

11.3 Thermal Management

Power dissipation in the LMK00334 device can be high enough to require attention to thermal management. For reliability and performance reasons the die temperature should be limited to a maximum of 125°C. That is, as an estimate, T_A (ambient temperature) plus device power dissipation times $R_{\theta JA}$ should not exceed 125°C.

The package of the device has an exposed pad that provides the primary heat removal path as well as excellent electrical grounding to the printed-circuit board. To maximize the removal of heat from the package, a thermal land pattern including multiple vias to a ground plane must be incorporated on the PCB within the footprint of the package. The exposed pad must be soldered down to ensure adequate heat conduction out of the package.

A recommended land and via pattern is shown in 图 11-2. More information on soldering WQFN packages can be obtained at: <https://www.ti.com/packaging>.



图 11-2. Recommended Land and Via Pattern

To minimize junction temperature, TI recommends building a simple heat sink into the PCB (if the ground plane layer is not exposed). This is done by including a copper area of about 2 square inches on the opposite side of the PCB from the device. This copper area may be plated or solder coated to prevent corrosion but should not have conformal coating (if possible), which could provide thermal insulation. The vias shown in 图 11-2 should connect these top and bottom copper layers and to the ground layer. These vias act as *heat pipes* to carry the thermal energy away from the device side of the board to where it can be more effectively dissipated.

12 Device and Documentation Support

12.1 Documentation Support

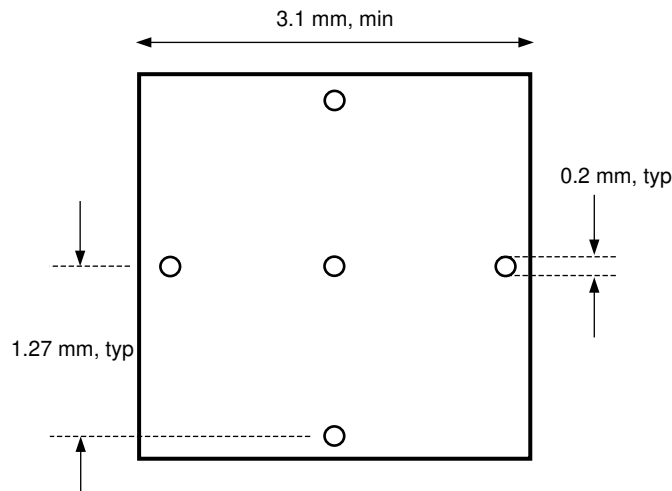
12.1.1 Related Documentation

For related documents, see the following:

- [Absolute Maximum Ratings for Soldering](#) (SNOA549)
- [Common Data Transmission Parameters and their Definitions](#) (SNLA036)
- ["How to Optimize Clock Distribution in PCIe Applications"](#) on the Texas Instruments E2E community forum
- [LMK00338EVM User's Guide](#) (SNAU155)
- [Semiconductor and IC Package Thermal Metrics](#) (SPRA953).

12.2 接收文档更新通知

要接收文档更新通知，请导航至 ti.com 上的器件产品文件夹。点击 [订阅更新](#) 进行注册，即可每周接收产品信息更改摘要。有关更改的详细信息，请查看任何已修订文档中包含的修订历史记录。

12.3 支持资源

[TI E2E™ 支持论坛](#) 是工程师的重要参考资料，可直接从专家获得快速、经过验证的解答和设计帮助。搜索现有解答或提出自己的问题可获得所需的快速设计帮助。

链接的内容由各个贡献者“按原样”提供。这些内容并不构成 TI 技术规范，并且不一定反映 TI 的观点；请参阅 TI 的 [《使用条款》](#)。

12.4 Trademarks

TI E2E™ is a trademark of Texas Instruments.

所有商标均为其各自所有者的财产。

12.5 Electrostatic Discharge Caution



This integrated circuit can be damaged by ESD. Texas Instruments recommends that all integrated circuits be handled with appropriate precautions. Failure to observe proper handling and installation procedures can cause damage.

ESD damage can range from subtle performance degradation to complete device failure. Precision integrated circuits may be more susceptible to damage because very small parametric changes could cause the device not to meet its published specifications.

12.6 术语表

[TI 术语表](#) 本术语表列出并解释了术语、首字母缩略词和定义。

13 Mechanical, Packaging, and Orderable Information

The following pages include mechanical, packaging, and orderable information. This information is the most current data available for the designated devices. This data is subject to change without notice and revision of this document. For browser-based versions of this data sheet, refer to the left-hand navigation.

重要声明和免责声明

TI 提供技术和可靠性数据 (包括数据表)、设计资源 (包括参考设计)、应用或其他设计建议、网络工具、安全信息和其他资源, 不保证没有瑕疵且不做任何明示或暗示的担保, 包括但不限于对适销性、某特定用途方面的适用性或不侵犯任何第三方知识产权的暗示担保。

这些资源可供使用 TI 产品进行设计的熟练开发人员使用。您将自行承担以下全部责任: (1) 针对您的应用选择合适的 TI 产品, (2) 设计、验证并测试您的应用, (3) 确保您的应用满足相应标准以及任何其他安全、安保或其他要求。这些资源如有变更, 恕不另行通知。TI 授权您仅可将这些资源用于研发本资源所述的 TI 产品的应用。严禁对这些资源进行其他复制或展示。您无权使用任何其他 TI 知识产权或任何第三方知识产权。您应全额赔偿因在这些资源的使用中对 TI 及其代表造成的任何索赔、损害、成本、损失和债务, TI 对此概不负责。

TI 提供的产品受 TI 的销售条款 (<https://www.ti.com/legal/termsofsale.html>) 或 [ti.com](https://www.ti.com) 上其他适用条款/TI 产品随附的其他适用条款的约束。TI 提供这些资源并不会扩展或以其他方式更改 TI 针对 TI 产品发布的适用的担保或担保免责声明。

邮寄地址: Texas Instruments, Post Office Box 655303, Dallas, Texas 75265
Copyright © 2021, 德州仪器 (TI) 公司

PACKAGING INFORMATION

Orderable Device	Status (1)	Package Type	Package Drawing	Pins	Package Qty	Eco Plan (2)	Lead finish/ Ball material (6)	MSL Peak Temp (3)	Op Temp (°C)	Device Marking (4/5)	Samples
LMK00334RTVR	ACTIVE	WQFN	RTV	32	1000	RoHS & Green	SN	Level-3-260C-168 HR	-40 to 85	K00334	Samples
LMK00334RTVT	ACTIVE	WQFN	RTV	32	250	RoHS & Green	SN	Level-3-260C-168 HR	-40 to 85	K00334	Samples

(1) The marketing status values are defined as follows:

ACTIVE: Product device recommended for new designs.

LIFEBUY: TI has announced that the device will be discontinued, and a lifetime-buy period is in effect.

NRND: Not recommended for new designs. Device is in production to support existing customers, but TI does not recommend using this part in a new design.

PREVIEW: Device has been announced but is not in production. Samples may or may not be available.

OBSOLETE: TI has discontinued the production of the device.

(2) **RoHS:** TI defines "RoHS" to mean semiconductor products that are compliant with the current EU RoHS requirements for all 10 RoHS substances, including the requirement that RoHS substance do not exceed 0.1% by weight in homogeneous materials. Where designed to be soldered at high temperatures, "RoHS" products are suitable for use in specified lead-free processes. TI may reference these types of products as "Pb-Free".

RoHS Exempt: TI defines "RoHS Exempt" to mean products that contain lead but are compliant with EU RoHS pursuant to a specific EU RoHS exemption.

Green: TI defines "Green" to mean the content of Chlorine (Cl) and Bromine (Br) based flame retardants meet JS709B low halogen requirements of <=1000ppm threshold. Antimony trioxide based flame retardants must also meet the <=1000ppm threshold requirement.

(3) MSL, Peak Temp. - The Moisture Sensitivity Level rating according to the JEDEC industry standard classifications, and peak solder temperature.

(4) There may be additional marking, which relates to the logo, the lot trace code information, or the environmental category on the device.

(5) Multiple Device Markings will be inside parentheses. Only one Device Marking contained in parentheses and separated by a "~" will appear on a device. If a line is indented then it is a continuation of the previous line and the two combined represent the entire Device Marking for that device.

(6) Lead finish/Ball material - Orderable Devices may have multiple material finish options. Finish options are separated by a vertical ruled line. Lead finish/Ball material values may wrap to two lines if the finish value exceeds the maximum column width.

Important Information and Disclaimer:The information provided on this page represents TI's knowledge and belief as of the date that it is provided. TI bases its knowledge and belief on information provided by third parties, and makes no representation or warranty as to the accuracy of such information. Efforts are underway to better integrate information from third parties. TI has taken and continues to take reasonable steps to provide representative and accurate information but may not have conducted destructive testing or chemical analysis on incoming materials and chemicals. TI and TI suppliers consider certain information to be proprietary, and thus CAS numbers and other limited information may not be available for release.

In no event shall TI's liability arising out of such information exceed the total purchase price of the TI part(s) at issue in this document sold by TI to Customer on an annual basis.

OTHER QUALIFIED VERSIONS OF LMK00334 :

- Automotive : [LMK00334-Q1](#)

NOTE: Qualified Version Definitions:

- Automotive - Q100 devices qualified for high-reliability automotive applications targeting zero defects

TAPE AND REEL INFORMATION

QUADRANT ASSIGNMENTS FOR PIN 1 ORIENTATION IN TAPE



*All dimensions are nominal

Device	Package Type	Package Drawing	Pins	SPQ	Reel Diameter (mm)	Reel Width W1 (mm)	A0 (mm)	B0 (mm)	K0 (mm)	P1 (mm)	W (mm)	Pin1 Quadrant
LMK00334RTVR	WQFN	RTV	32	1000	178.0	12.4	5.3	5.3	1.3	8.0	12.0	Q1
LMK00334RTVT	WQFN	RTV	32	250	178.0	12.4	5.3	5.3	1.3	8.0	12.0	Q1

TAPE AND REEL BOX DIMENSIONS

*All dimensions are nominal

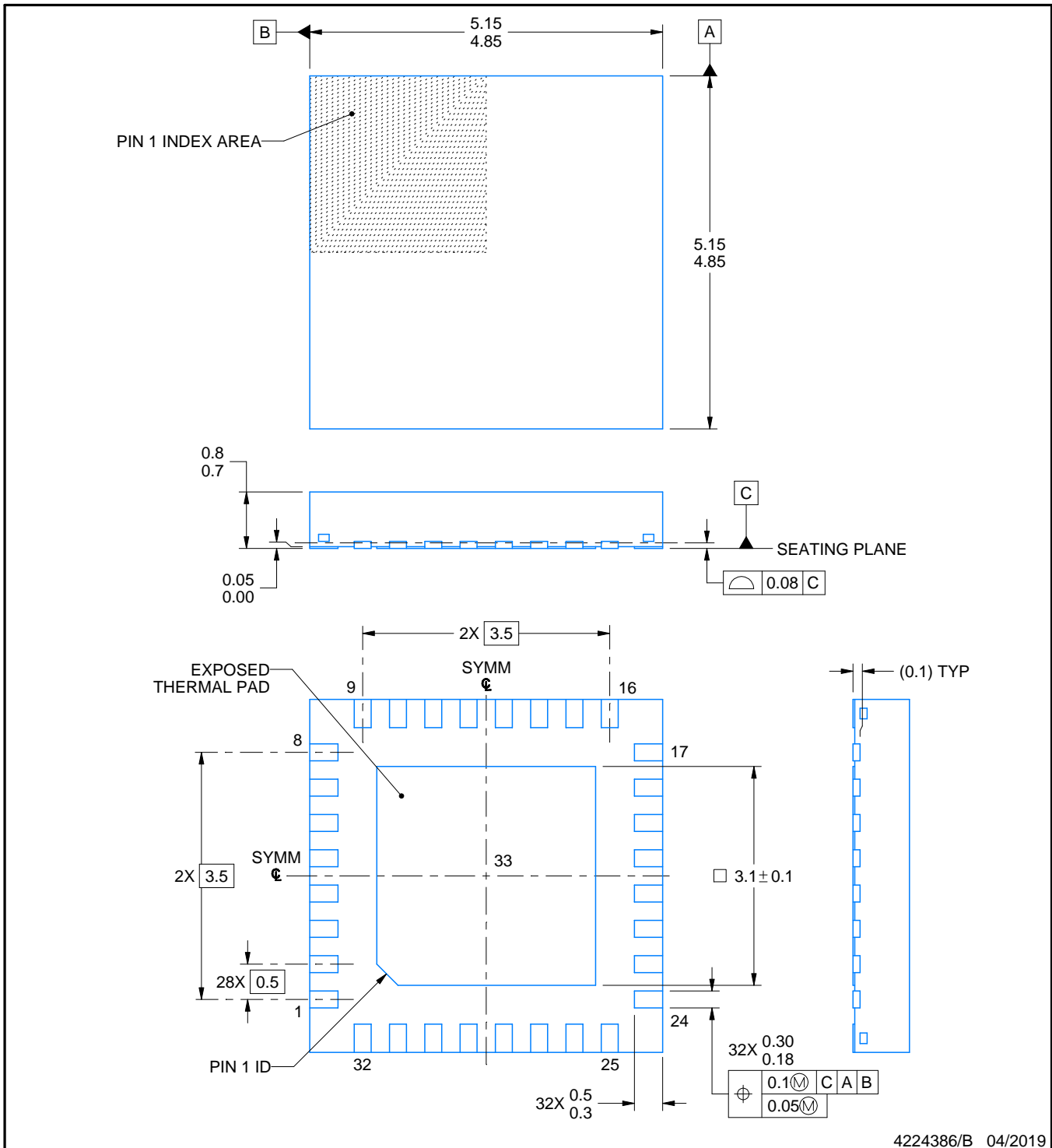
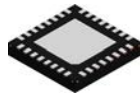
Device	Package Type	Package Drawing	Pins	SPQ	Length (mm)	Width (mm)	Height (mm)
LMK00334RTVR	WQFN	RTV	32	1000	208.0	191.0	35.0
LMK00334RTVT	WQFN	RTV	32	250	208.0	191.0	35.0



NOTES:

1. All linear dimensions are in millimeters. Any dimensions in parenthesis are for reference only. Dimensioning and tolerancing per ASME Y14.5M.
2. This drawing is subject to change without notice.
3. The package thermal pad must be soldered to the printed circuit board for thermal and mechanical performance.

EXAMPLE BOARD LAYOUT

RTV0032A

WQFN - 0.8 mm max height

PLASTIC QUAD FLATPACK - NO LEAD

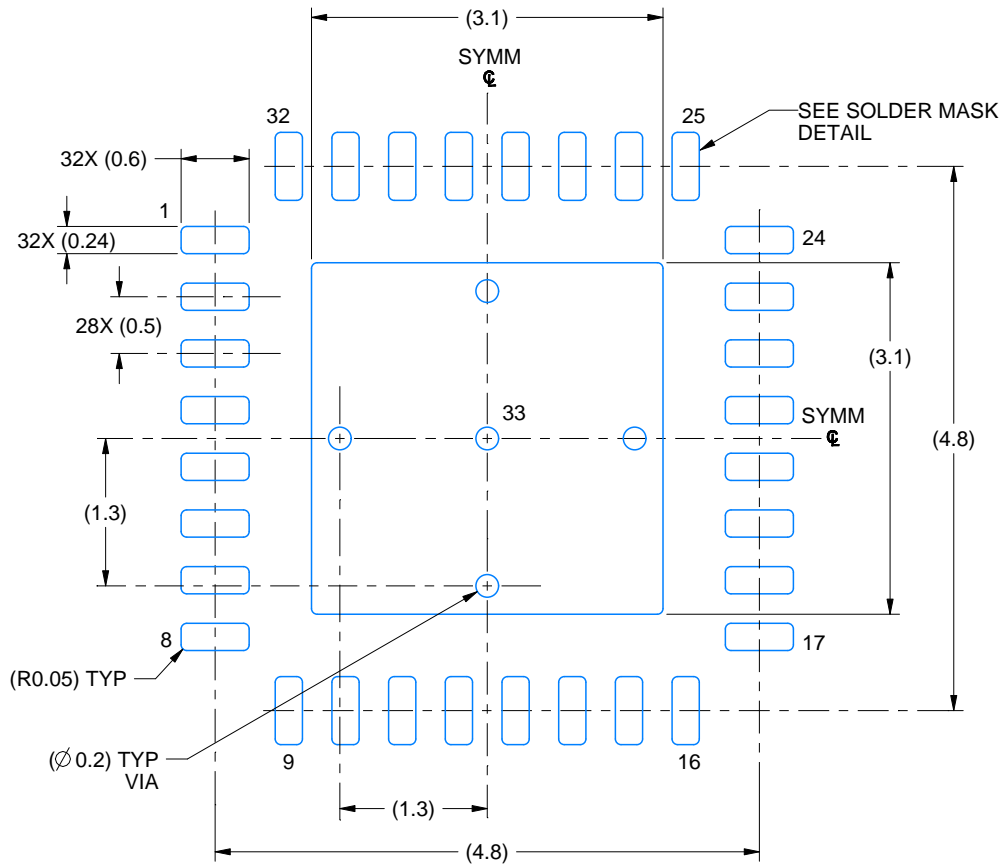

LAND PATTERN EXAMPLE
EXPOSED METAL SHOWN
SCALE: 15X

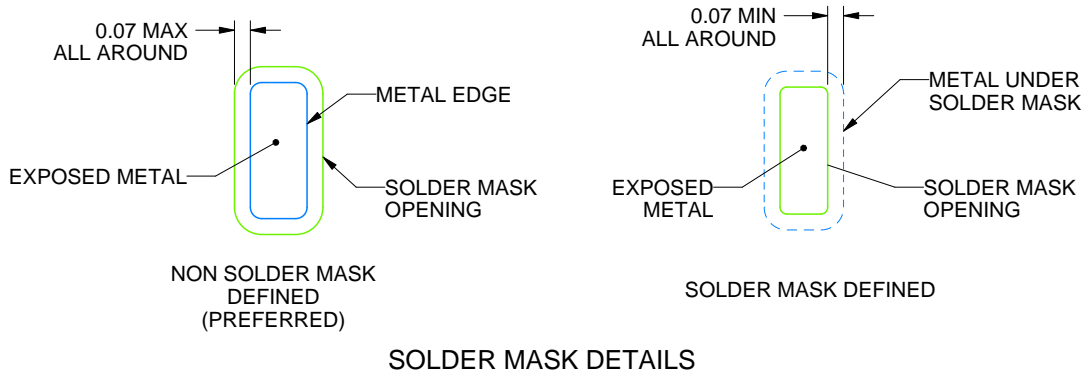

SOLDER MASK DETAILS

4224386/B 04/2019

NOTES: (continued)

4. This package is designed to be soldered to a thermal pad on the board. For more information, see Texas Instruments literature number SLUA271 (www.ti.com/lit/sluea271).
5. Vias are optional depending on application, refer to device data sheet. If any vias are implemented, refer to their locations shown on this view. It is recommended that vias under paste be filled, plugged or tented.

EXAMPLE STENCIL DESIGN

RTV0032A

WQFN - 0.8 mm max height

PLASTIC QUAD FLATPACK - NO LEAD

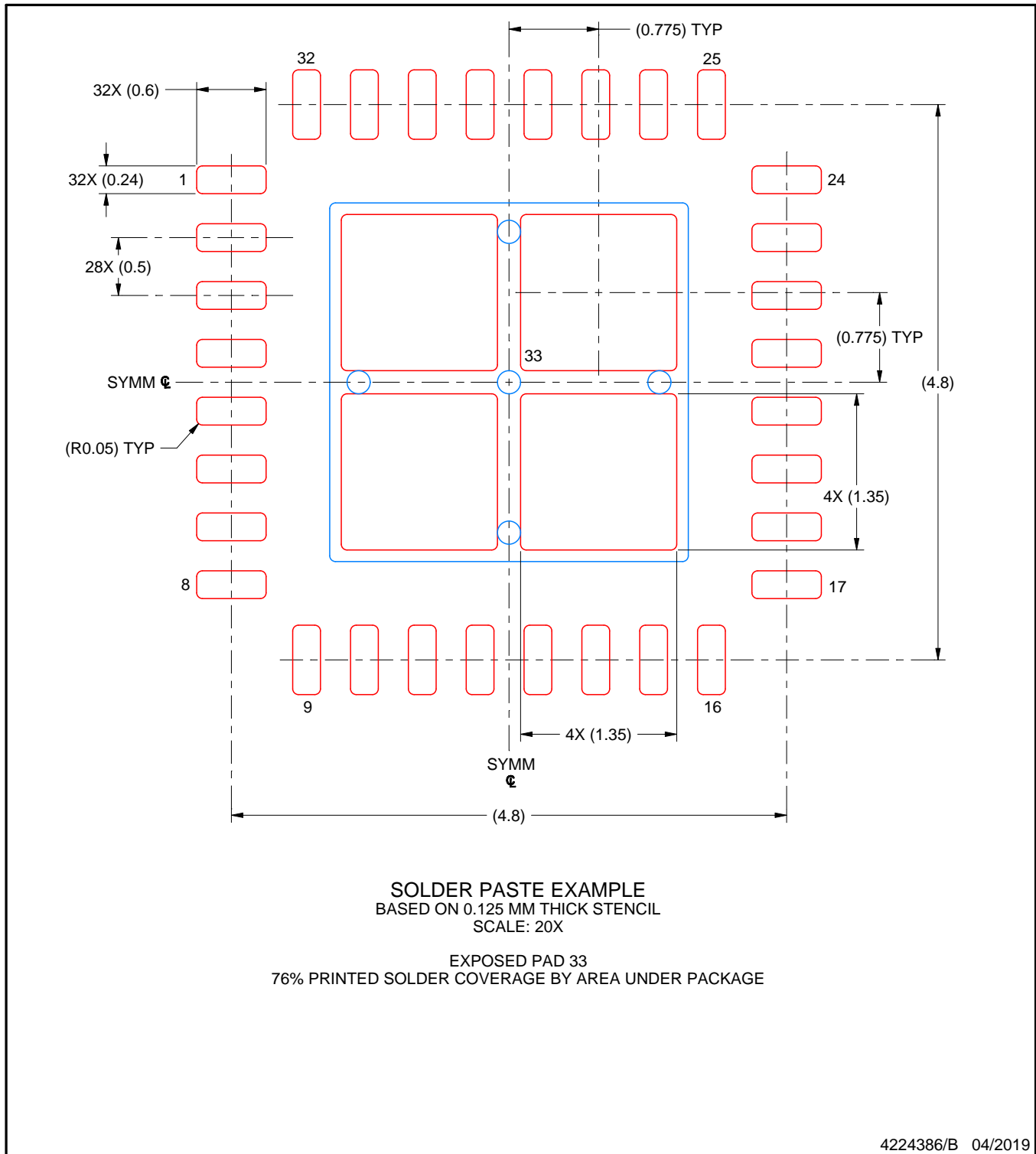

NOTES: (continued)

6. Laser cutting apertures with trapezoidal walls and rounded corners may offer better paste release. IPC-7525 may have alternate design recommendations.

重要声明和免责声明

TI“按原样”提供技术和可靠性数据（包括数据表）、设计资源（包括参考设计）、应用或其他设计建议、网络工具、安全信息和其他资源，不保证没有瑕疵且不做任何明示或暗示的担保，包括但不限于对适销性、某特定用途方面的适用性或不侵犯任何第三方知识产权的暗示担保。

这些资源可供使用 TI 产品进行设计的熟练开发人员使用。您将自行承担以下全部责任：(1) 针对您的应用选择合适的 TI 产品，(2) 设计、验证并测试您的应用，(3) 确保您的应用满足相应标准以及任何其他功能安全、信息安全、监管或其他要求。

这些资源如有变更，恕不另行通知。TI 授权您仅可将这些资源用于研发本资源所述的 TI 产品的应用。严禁对这些资源进行其他复制或展示。您无权使用任何其他 TI 知识产权或任何第三方知识产权。您应全额赔偿因在这些资源的使用中对 TI 及其代表造成的任何索赔、损害、成本、损失和债务，TI 对此概不负责。

TI 提供的产品受 [TI 的销售条款](#) 或 [ti.com](#) 上其他适用条款/TI 产品随附的其他适用条款的约束。TI 提供这些资源并不会扩展或以其他方式更改 TI 针对 TI 产品发布的适用的担保或担保免责声明。

TI 反对并拒绝您可能提出的任何其他或不同的条款。

邮寄地址：Texas Instruments, Post Office Box 655303, Dallas, Texas 75265

Copyright © 2022，德州仪器 (TI) 公司