

# 具有 NVM 和 PMBus™ 的 TPS53681 双通道(6-Phase + 2-Phase) or (5-Phase + 3-Phase) D-CAP+™ 降压多相控制器

## 1 特性

- 转换输入电压范围：4.5V 至 17V
- 具有可选 5mV 或 10mV 分辨率的 8 位 DAC，两个通道的输出范围均为 0.25V 至 1.52V 或 0.5V 至 2.8125V。
- 相位配置
  - 最高（6 相位 + 2 相位）或（5 相位 + 3 相位）
  - 最低（1 相位 + 1 相位）
- 无驱动器配置，有助于实现高效的高频开关
- 可通过 PMBus 接口配置可编程压摆率，从而实现动态输出电压转换
- 通过闭环频率控制进行频率选择：300kHz 至 1MHz
- 可编程内部环路补偿
- 可通过非易失性存储器 (NVM) 进行配置，从而减少外部组件数量
- 单独的相电流校准和报告
- 可通过可编程电流阈值实现动态切相，从而优化轻负载和重负载下的效率
- 快速添相以减弱下冲 (USR)
- 与 TI NexFET™ 功率级完全兼容，可实现高密度解决方案
- 精确可调电压定位
- 已获专利 AutoBalance™ 相位均衡
- 可选 16 级每相位电流限制
- PMBus™ 用于电压、电流、功率、温度和故障条件遥测的系统接口
- 低静态电流
- 5 mm × 5 mm 40 引脚 QFN PowerPad™ 封装

## 2 应用

- 网络处理器电源 (Broadcom®、Cavium®)
- 数据中心、园区和分支交换机
- 核心和边缘路由器
- 高电流 FPGA 电源 (Intel®、Xilinx®)

## 3 说明

TPS53681 是一款多相降压控制器，具有两个通道、内置非易失性存储器 (NVM) 和 PMBus™ 接口，且可与 TINexFET™ 功率级完全兼容。高级控制特性，例如具有下冲减弱 (USR) 功能的 D-CAP+™ 架构，可提供快速瞬态响应、低输出电容和高效。该器件还提供全新的相位交错策略和动态切相功能，可有效提升轻负载条件下的效率。该器件通过可调压摆率支持快速动态电压转换。此外，该器件还支持 PMBus 通信接口，可向系统报告遥测的电压、电流、功率、温度和故障状况。所有可编程参数均可通过 PMBus 接口进行配置，而且可作为新的默认值存储在 NVM 中，以尽可能减少外部组件数量。

TPS53681 器件采用热增强型 40 引脚 QFN 封装，额定工作温度为 -40°C 到 125°C。

器件信息<sup>(1)</sup>

器件型号	封装	封装尺寸 (标称值)
TPS53681	QFN (40)	5mm × 5mm

(1) 如需了解所有可用封装，请参阅数据表末尾的可订购产品附录。

图 1. 简化应用

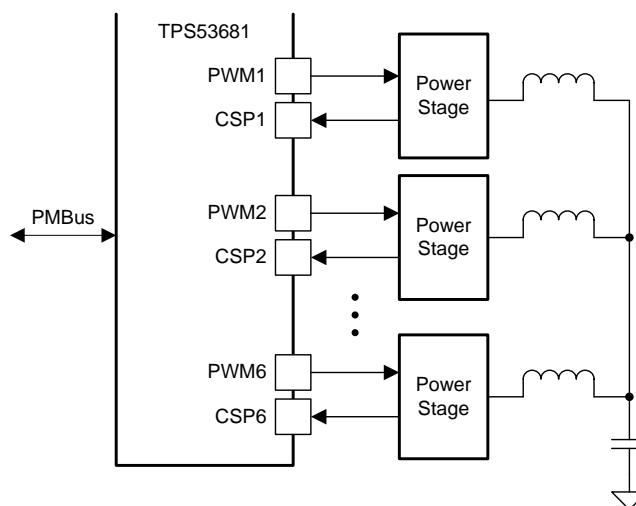

Copyright © 2017, Texas Instruments Incorporated



目录

1	特性 .....	1	6.20	Boot Voltage and TMAX Settings .....	21
2	应用 .....	1	6.21	Protections: OVP and UVP .....	22
3	说明 .....	1	6.22	Protections: ATSEN and BTSEN Pin Voltage Levels and Fault .....	22
4	修订历史记录 .....	2	6.23	PWM: I/O Voltage and Current .....	23
5	<b>Pin Configuration and Functions</b> .....	3	6.24	Dynamic Phase Add and Drop .....	24
6	<b>Specifications</b> .....	6	6.25	Typical Characteristics .....	34
6.1	Absolute Maximum Ratings .....	6	7	<b>Detailed Description</b> .....	35
6.2	ESD Ratings .....	6	7.1	Overview .....	35
6.3	Recommended Operating Conditions .....	6	7.2	Functional Block Diagram .....	35
6.4	Thermal Information .....	7	7.3	Feature Description .....	35
6.5	Supply: Currents, UVLO, and Power-On Reset .....	7	7.4	Device Functional Modes .....	43
6.6	References: DAC and VREF .....	8	7.5	Programming .....	43
6.7	Voltage Sense: AVSP and BVSP, AVSN and BVSN .....	8	8	<b>Applications, Implementation, and Layout</b> .....	105
6.8	Telemetry .....	9	8.1	Application Information .....	105
6.9	Input Current Sensing .....	10	8.2	Typical Application .....	105
6.10	Programmable Loadline Settings .....	11	9	<b>Power Supply Recommendations</b> .....	116
6.11	Current Sense and Calibration .....	15	10	<b>Layout</b> .....	117
6.12	Logic Interface Pins: AVR_EN, AVR_RDY, BVR_EN, BVR_RDY, RESET, VR_FAULT, VR_HOT .....	15	10.1	Layout Guidelines .....	117
6.13	I/O Timing .....	16	10.2	Layout Examples .....	118
6.14	PMBus Address Setting .....	17	11	<b>器件和文档支持</b> .....	120
6.15	Overcurrent Limit Thresholds .....	18	11.1	接收文档更新通知 .....	120
6.16	Switching Frequency .....	19	11.2	社区资源 .....	120
6.17	Slew Rate Settings .....	19	11.3	商标 .....	120
6.18	Ramp Selections .....	20	11.4	静电放电警告 .....	120
6.19	Dynamic Integration and Undershoot Reduction ..	20	11.5	术语表 .....	120
			12	<b>机械、封装和可订购信息</b> .....	121

4 修订历史记录

注：之前版本的页码可能与当前版本有所不同。

Changes from Revision A (November 2018) to Revision B	Page
• Updated the device NVM default values in <a href="#">Supported Commands</a> .....	45

Changes from Original (June 2017) to Revision A	Page
• 更新了应用 列表 .....	1
• 已添加 (21h) VOUT_COMMAND register table in <a href="#">Output Voltage Margin Testing</a> section .....	67

## 5 Pin Configuration and Functions

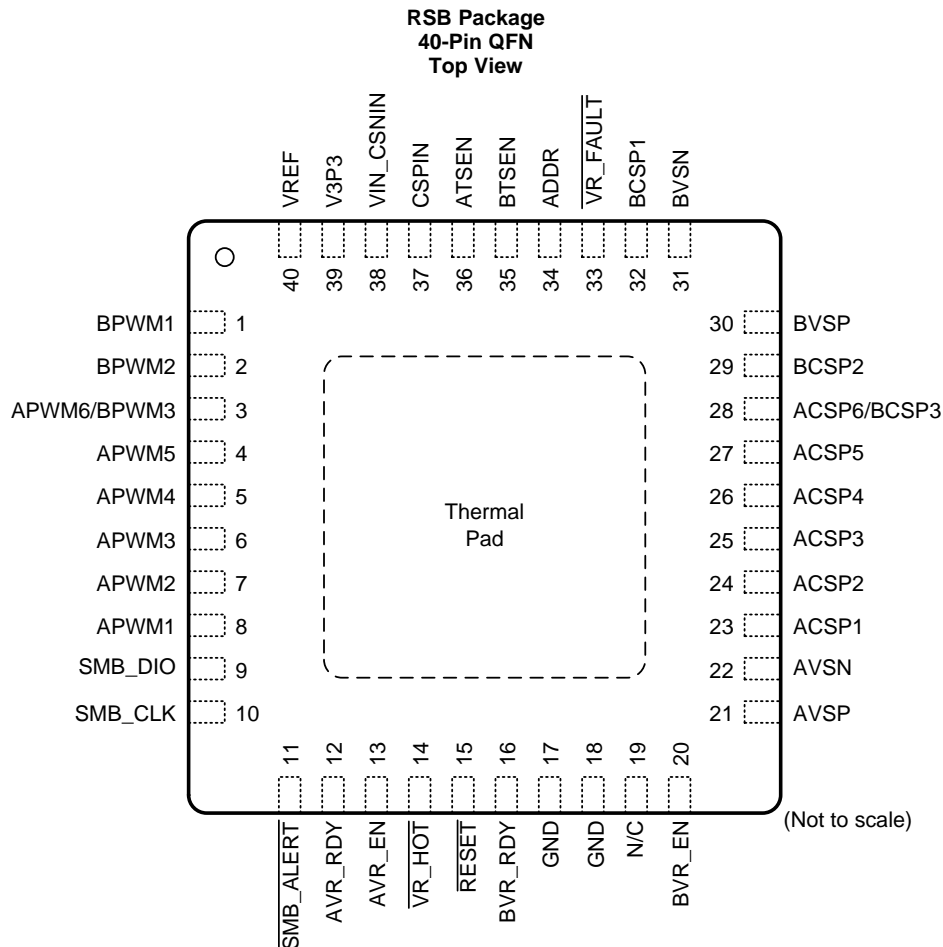

Thermal pad acts as AGND.

NC = not connected

### Pin Functions

PIN		I/O <sup>(1)</sup>	DESCRIPTION
NAME	NO.		
ACSP1	23	I	Current sense input for the channel A. Connect to the IOOUT pin of TI smart power stages. Tie the ACSP5, ACSP4, ACSP3, or ACSP2 pin to the V3P3 pin according to <a href="#">Table 1</a> to disable the corresponding phase.
ACSP2	24		
ACSP3	25		
ACSP4	26		
ACSP5	27		
ACSP6/BCSP3	28		Current sense inputs for channel A or channel B based on NVM option. Connect to the IOOUT pin of smart power stages. Tie ACSP6/BCSP3 to the 3.3-V supply to disable corresponding phase.
ADDR	34	I	Voltage divider to VREF and GND. The voltage level sets the 7-bit PMBus address with an ADC. Address is latched at 3.3-V power up.
APWM1	8	O	PWM signal for phase 1 of channel A.
APWM2	7	O	PWM signal for phase 2 of channel A.
APWM3	6	O	PWM signal for phase 3 of channel A.
APWM4	5	O	PWM signal for phase 4 of channel A.
APWM5	4	O	PWM signal for phase 5 of channel A.

(1) G = ground, I = input, O = output, P = power input

**Pin Functions (continued)**

PIN		I/O <sup>(1)</sup>	DESCRIPTION
NAME	NO.		
APWM6/BPWM3	3	O	PWM signal for phase 6 of channel A, or phase 3 of channel B, based on the NVM option.
ATSEN	36	O	Connect to TAO pin of TI smart power stages of Channel A to sense the highest temperature of the power stages and to sense the built-in fault signal from power stages
AVR_EN	13	I	Active high enable input for channel A. Asserting the AVR_EN pin activates channel A. Re-cycling BVR_EN pin clears the faults of channel A.
AVR_RDY	12	O	Power good open-drain output signal of channel A. This open drain output requires an external pull-up resistor. The AVR_RDY pin is pulled low when a shutdown fault occurs.
AVSN	22	I	Negative input of the remote voltage sense of channel A.
AVSP	21	I	Positive input of the remote voltage sense of channel A.
BCSP1	32	I	Current sense input for channel B. Connect to the IOUT pins of TI smart power stages. If channel B is not used, then connect the BCSP1 pin to GND.
BCSP2	29	I	Current sense input for channel B. Connect to the IOUT pins of TI smart power stages. Tie the BCSP2 pin to the V3P3 pin according to <a href="#">Table 1</a> to disable the corresponding phase.
BPWM1	1	O	PWM signal for phase 1 of channel B
BPWM2	2	O	PWM signal for phase 2 of channel B
BTSEN	35	O	Connect to TAO pin of TI smart power stages of Channel B to sense the highest temperature of the power stages and to sense the built-in fault signal from power stages
BVR_EN	20	I	Active high enable input for channel B. Asserting the BVR_EN pin activates channel B. Re-cycling BVR_EN pin clears the faults of channel B.
BVR_RDY	16	O	Power good open-drain output signal of channel B. This open drain output requires an external pull-up resistor. BVR_RDY is pulled low when a shutdown fault occurs.
BVSN	31	I	Negative input of the remote voltage sense of channel B. If channel B is not used, connect BVSN to GND.
BVSP	30	I	Positive input of the remote voltage sense of channel B. If channel B is not used, connect BVSP to GND.
CSPIN	37	I	Input voltage from the positive terminal connecting to the input current sensing shunt. When input current sensing is not used, short CSPIN to VIN_CSNIN and connect to the converter input voltage (example: 12 V).
GND	17	G	Connect to GND
	18		
NC	19	–	No connection.
$\overline{\text{RESET}}$	15	I/O	Resets the output voltage to BOOT voltage
$\overline{\text{SMB\_ALERT}}$	11	I/O	SMBus or I <sup>2</sup> C bi-directional $\overline{\text{ALERT}}$ pin interface. (Open drain)
SMB_CLK	10	I	SMBus or I <sup>2</sup> C serial clock interface. (Open drain)
SMB_DIO	9	I/O	SMBus or I <sup>2</sup> C bi-directional serial data interface. (Open drain)
V3P3	39	P	3.3-V power input. Bypass to GND with a ceramic capacitor with a value greater than or equal to 1 $\mu\text{F}$ . Used to power all digital logic circuits.
VIN_CSNIN	38	P	Input voltage sensing for on-time control and telemetry. Serves as the negative terminal connecting to the input current sensing shunt. When input current sensing is not used, short VIN_CSNIN to CSPIN and connect to the converter input voltage (example: 12 V).
$\overline{\text{VR\_FAULT}}$	33	O	VR fault indicator. (Open-drain). The failures include the high-side FETs short, over-voltage, over-temperature, and the input over-current conditions. Use the fault signal on the platform to remove the power source by turning off the AC power supply. When the failure occurs, the $\overline{\text{VR\_FAULT}}$ pin is LOW, and put the controller into latch-off mode. One NVM bit is used to select whether or not the faults from channel B asserts the $\overline{\text{VR\_FAULT}}$ pin.
VREF	40	O	1.7-V LDO reference voltage. Bypass to GND with 1- $\mu\text{F}$ ceramic capacitor. Connect the VREF pin to the REFIN pin of the TI smart power stages as the current sense common-mode voltage.
$\overline{\text{VR\_HOT}}$	14	O	Active low external temperature indicator.
Thermal Pad		G	Analog ground pad. Connect to GND plan with vias.

**Table 1. Current Sense Inputs for Active Phases**

Active Phase Channel		ACSP1	ACSP2	ACSP3	ACSP4	ACSP5	ACSP6	BSCP1	BSCP2
A	B								
1	0	AIOUT1	V3P3	n/a	n/a	n/a	n/a	GND	V3P3
2	1	AIOUT1	AIOUT2	V3P3	n/a	n/a	n/a	BIOUT1	V3P3
3	1	AIOUT1	AIOUT2	AIOUT3	V3P3	n/a	n/a	BIOUT1	V3P3
4	1	AIOUT1	AIOUT2	AIOUT3	AIOUT4	V3P3	n/a	BIOUT1	V3P3
5	1	AIOUT1	AIOUT2	AIOUT3	AIOUT4	AIOUT5	V3P3	BIOUT1	V3P3
6	0	AIOUT1	AIOUT2	AIOUT3	AIOUT4	AIOUT5	AIOUT6	GND	V3P3
6 <sup>(1)</sup>	1	AIOUT1	AIOUT2	AIOUT3	AIOUT4	AIOUT5	AIOUT6	BIOUT1	V3P3
6	2	AIOUT1	AIOUT2	AIOUT3	AIOUT4	AIOUT5	AIOUT6	BIOUT1	BIOUT2
5	2	AIOUT1	AIOUT2	AIOUT3	AIOUT4	AIOUT5	V3P3	BIOUT1	BIOUT2
5 <sup>(1)</sup>	3	AIOUT1	AIOUT2	AIOUT3	AIOUT4	AIOUT5	BIOUT3	BIOUT1	BIOUT2

(1) For  $n+1$  or  $n+3$  applications, the NVM setting must be changed. See also the [Phase Configuration for Channel B](#) section.

## 6 Specifications

### 6.1 Absolute Maximum Ratings

over operating free-air temperature range (unless otherwise noted)

		MIN	MAX	UNIT
Input voltage <sup>(1)</sup> <sup>(2)</sup>	CSPIN, VIN_CSNIN	-0.3	19	V
	ACSP1, ACSP2, ACSP3, ACSP4, ACSP5, ACSP6/BCSP3, ADDR, ATSEN, AVR_EN, AVSP, BCSP1, BCSP2, BTSEN, BVR_EN, BVSP, RESET, SMB_CLK, SMB_DIO, V3P3	-0.3	3.6	V
	AGND, AVSN, BVSN	-0.3	0.3	V
Output voltage <sup>(1)</sup> <sup>(2)</sup>	APWM1, APWM2, APWM3, APWM4, APWM5, APWM6/BPWM3, BPWM2, AVR_RDY, BPWM1, BVR_RDY, SMB_ALERT, VREF, VR_FAULT, VR_HOT	-0.3	3.6	V
Operating junction temperature, T <sub>J</sub>		-40	150	°C
Storage temperature, T <sub>STG</sub>		-55	150	°C

- (1) Stresses beyond those listed under "absolute maximum ratings" may cause permanent damage to the device. These are stress ratings only and functional operation of the device at these or any other conditions beyond those indicated under "recommended operating conditions" is not implied. Exposure to absolute-maximum-rated conditions for extended periods may affect device reliability.
- (2) All voltage values are with respect to the network ground terminal GND unless otherwise noted.

### 6.2 ESD Ratings

		VALUE	UNIT
V <sub>(ESD)</sub>	Electrostatic discharge	Human-body model (HBM), per ANSI/ESDA/JEDEC JS-001 <sup>(1)</sup>	±3000
		Charged-device model (CDM), per JEDEC specification JESD22-C101 <sup>(2)</sup>	±1500

- (1) JEDEC document JEP155 states that 500-V HBM allows safe manufacturing with a standard ESD control process.
- (2) JEDEC document JEP157 states that 250-V CDM allows safe manufacturing with a standard ESD control process.

### 6.3 Recommended Operating Conditions

		MIN	NOM	MAX	UNIT
Input voltage	CSPIN, VIN_CSNIN	4.5	12	17	V
	V3P3	2.97	3.3	3.5	
	ACSP1, ACSP2, ACSP3, ACSP4, ACSP5, ACSP6/BCSP3, ADDR, ATSEN, AVR_EN, AVSP, BCSP1, BCSP2, BTSEN, BVR_EN, BVSP, RESET, SMB_CLK, SMB_DIO, V3P3	-0.1		3.5	
	AGND, AVSN, BVSN	-0.1		0.1	
Output voltage	VREF	-0.1		1.72	V
	APWM1, APWM2, APWM3, APWM4, APWM5, APWM6/BPWM3, BPWM2, AVR_RDY, BPWM1, BVR_RDY, SMB_ALERT, VREF, VR_FAULT, VR_HOT	-0.1		3.5	
Ambient temperature, T <sub>A</sub>		-40		125	°C

## 6.4 Thermal Information

THERMAL METRIC <sup>(1)</sup>		TPS53681	
		RSB (WQFN)	
		40 PINS	
Symbol	Description	Value	Unit
$R_{\theta JA}$	Junction-to-ambient thermal resistance	34.1	°C/W
$R_{\theta JC(top)}$	Junction-to-case (top) thermal resistance	16.6	°C/W
$R_{\theta JB}$	Junction-to-board thermal resistance	5.8	°C/W
$\Psi_{JT}$	Junction-to-top characterization parameter	0.2	°C/W
$\Psi_{JB}$	Junction-to-board characterization parameter	5.7	°C/W
$R_{\theta JC(bot)}$	Junction-to-case (bottom) thermal resistance	0.9	°C/W

(1) For more information about traditional and new thermal metrics, see the [Semiconductor and IC Package Thermal Metrics](#) application report.

## 6.5 Supply: Currents, UVLO, and Power-On Reset

$V_{IN\_CSNIN} = 12.0\text{ V}$ ,  $V_{V3P3} = 3.3\text{ V}$ ,  $V_{AVSN} = \text{GND}$ ,  $V_{BVSN} = \text{GND}$ ,  $V_{AVSP} = V_{OUTA}$ ,  $V_{BVSP} = V_{OUTB}$  (Unless otherwise noted).

PARAMETER		TEST CONDITIONS	MIN	TYP	MAX	UNIT
<b>Supply: Currents, UVLO, and Power-On Reset</b>						
$I_{V3P3}$	V3P3 supply current	$VDAC < VSP < VDAC + 100\text{m V}$ , ENABLE = 'HI'		13	18	mA
$I_{V3P3SBY}$	V3P3 standby current	ENABLE = 'LO'		9	13.5	mA
$V_{3NORMAL}$	V3P3 normal range	Normal operation	2.97		3.5	V
$V_{3UVLOH}$	V3P3 UVLO 'OK' threshold	Ramp up	2.85		2.95	V
$V_{3UVLOL}$	V3P3 UVLO fault threshold	Ramp down	2.65		2.75	V
$V_{12ON}$	V12 UVLO 'OK' threshold	VIN_ON = 0xF010	3.75	4	4.25	V
		VIN_ON = 0xF015	5	5.25	5.5	V
		VIN_ON = 0xF019	6	6.25	6.5	V
		VIN_ON = 0xF01D	7	7.25	7.5	V
		VIN_ON = 0xF021	8	8.25	8.5	V
		VIN_ON = 0xF025	9	9.25	9.5	V
		VIN_ON = 0xF029	10	10.25	10.5	V
		VIN_ON = 0xF02D	11	11.25	11.5	V
		VIN_ON = others	invalid			
$V_{12UVF}$	V12 UVLO fault threshold	VIN_UV_FAULT_LIMIT = 0xF011	4	4.25	4.48	V
		VIN_UV_FAULT_LIMIT = 0xF80B	5.25	5.5	5.78	V
		VIN_UV_FAULT_LIMIT = 0xF80D	6.25	6.5	6.78	V
		VIN_UV_FAULT_LIMIT = 0xF80F	7.25	7.5	7.78	V
		VIN_UV_FAULT_LIMIT = 0xF811	8.25	8.5	8.78	V
		VIN_UV_FAULT_LIMIT = 0xF813	9.25	9.5	9.78	V
		VIN_UV_FAULT_LIMIT = 0xF815	10.25	10.5	10.78	V
		VIN_UV_FAULT_LIMIT = 0xF817	11.25	11.5	11.8	V
		VIN_UV_FAULT_LIMIT = others	invalid			

## 6.6 References: DAC and VREF

over recommended operating conditions (unless otherwise noted)

PARAMETER		TEST CONDITIONS	MIN	TYP	MAX	UNIT
V <sub>VIDSTP</sub>	VID step size	10 mV DAC: Change VID0 HI to LO to HI		10		mV
		5 mV DAC: Change VID0 HI to LO to HI		5		mV
V <sub>DAC0</sub>	VSP tolerance	10 mV DAC : $0.50 \leq V_{VSP} \leq 0.99$ V, I <sub>CORE</sub> = 0 A	-10		10	mV
V <sub>DAC1</sub>	VSP tolerance	5 mV DAC: $0.25 \leq V_{VSP} \leq 0.795$ V, I <sub>CORE</sub> = 0 A	-8		8	mV
		10 mV DAC: $1.00$ V $\leq V_{VSP} \leq 1.49$ V, I <sub>CORE</sub> = 0 A				
V <sub>DAC2</sub>	VSP tolerance	5 mV DAC: $0.8 \leq V_{VSP} \leq 0.995$ V, I <sub>CORE</sub> = 0 A	-5		5	mV
V <sub>DAC3</sub>	VSP tolerance	5mV DAC: $1.00$ V $\leq V_{VSP} \leq 1.52$ V, I <sub>CORE</sub> = 0 A	-0.5		0.5	%
		10 mV DAC: $1.50$ V $\leq V_{VSP} \leq 2.50$ V, I <sub>CORE</sub> = 0 A				
V <sub>VREF</sub>	VREF output deeper sleep	$2.97$ V $\leq V_{V3P3} \leq 3.5$ V, I <sub>VREF</sub> = 0 A	1.692	1.7	1.708	V
V <sub>VREFSRC</sub>	VREF output source	$0$ A $\leq I_{VREF} = 2$ mA	-8			mV
V <sub>VREFSNK</sub>	VREF output sink	$-2$ mA $\leq I_{VREF} = 0$ A			8	mV
K <sub>RATIO</sub>	Voltage divider ratio	VOUT_SCALE_LOOP = 0xe809, VOUT_SCALE_MONITOR = 0xe809		1.125		
		VOUT_SCALE_LOOP = 0xe808, VOUT_SCALE_MONITOR = 0xe808		1		
V <sub>OUT_TRIML</sub>	V <sub>OUT</sub> offset LSB	MFR_SPECIFIC_05 = 0x01	0	1.25	2.5	mV
V <sub>OUT_TRIMR</sub>	V <sub>OUT</sub> offset range	MFR_SPECIFIC_05 = 0x1F	37.5	38.75	40	mV
		MFR_SPECIFIC_05 = 0xA0	-43.25	-40	-37.75	
		MFR_SPECIFIC_05 = 0x5F	56.25	58.75	61.25	
		MFR_SPECIFIC_05 = 0xE0	-63	-60	-57	

## 6.7 Voltage Sense: AVSP and BVSP, AVSN and BVSN

over recommended operating conditions (unless otherwise noted)

PARAMETER		TEST CONDITIONS	MIN	TYP	MAX	UNIT
I <sub>AVSP</sub>	AVSP input bias current	Not in Fault, Disable or UVLO; V <sub>VSP</sub> = V <sub>VDAC</sub> = 2.3 V, V <sub>VSN</sub> = 0 V			75	μA
I <sub>AVSN</sub>	AVSN input bias current	Not in Fault, Disable or UVLO; V <sub>VSP</sub> = V <sub>VDAC</sub> = 2.3 V, V <sub>VSN</sub> = 0 V	-75			μA
I <sub>BVSP</sub>	BVSP input bias current	Not in Fault, Disable or UVLO; V <sub>VSP</sub> = V <sub>VDAC</sub> = 1.0 V, V <sub>VSN</sub> = 0 V			75	μA
I <sub>BVSN</sub>	BVSN input bias current	Not in Fault, Disable or UVLO; V <sub>VSP</sub> = V <sub>VDAC</sub> = 1.0 V, V <sub>VSN</sub> = 0 V	-75			μA

## 6.8 Telemetry

over recommended operating conditions (unless otherwise noted)

PARAMETER		TEST CONDITIONS	MIN	TYP	MAX	UNIT
V <sub>READ_VOUT</sub>	MFR_READ_VOUT Accuracy	5 mV DAC : 0.25 V ≤ V <sub>VSP</sub> ≤ 1.52 V 10 mV DAC: 0.5 ≤ V <sub>VSP</sub> ≤ 2.4 V	-12		12	mV
V <sub>READ_VIN</sub>	READ_VIN Accuracy	4.50 V ≤ V <sub>IN</sub> ≤ 17 V	-2.25%		2.25%	
I <sub>MON_ACC</sub>	Digital current monitor accuracy, Rail A (READ_IOUT)	6-phase, I <sub>CC(max)</sub> = 228 A, I <sub>OUT</sub> = 22.8 A	-7.3%		7.3%	
		6-phase, I <sub>CC(max)</sub> = 228 A, I <sub>OUT</sub> = 45.6 A	-4.2%		4.2%	
		6-phase, I <sub>CC(max)</sub> = 228 A, I <sub>OUT</sub> = 68.4 A	-3.1%		3.1%	
		6-phase, I <sub>CC(max)</sub> = 228 A, I <sub>OUT</sub> = 91.2 A	-2.5%		2.5%	
		6-phase, I <sub>CC(max)</sub> = 228 A, I <sub>OUT</sub> = 114 A	-2.3%		2.3%	
		6-phase, I <sub>CC(max)</sub> = 228 A, I <sub>OUT</sub> = 136.8 A	-2%		2%	
		6-phase, I <sub>CC(max)</sub> = 228 A, I <sub>OUT</sub> = 228 A	-1.6%		1.6%	
		6-phase, I <sub>CC(max)</sub> = 228 A, I <sub>OUT</sub> = 255 A	-1.5%		1.5%	
I <sub>MON_ACC</sub>	Digital current monitor accuracy, Rail A (READ_IOUT)	5-phase, I <sub>CC(max)</sub> = 228 A, I <sub>OUT</sub> = 22.8 A	-6.4%		6.4%	
		5-phase, I <sub>CC(max)</sub> = 228 A, I <sub>OUT</sub> = 45.6 A	-3.7%		3.7%	
		5-phase, I <sub>CC(max)</sub> = 228 A, I <sub>OUT</sub> = 68.4 A	-2.9%		2.9%	
		5-phase, I <sub>CC(max)</sub> = 228 A, I <sub>OUT</sub> = 91.2 A	-2.3%		2.3%	
		5-phase, I <sub>CC(max)</sub> = 228 A, I <sub>OUT</sub> = 114 A	-2.1%		2.1%	
		5-phase, I <sub>CC(max)</sub> = 228 A, I <sub>OUT</sub> = 136.8 A	-1.9%		1.9%	
		5-phase, I <sub>CC(max)</sub> = 228 A, I <sub>OUT</sub> = 228 A	-1.5%		1.5%	
I <sub>MON_ACC</sub>	Digital current monitor accuracy, Rail A (READ_IOUT)	4-phase, I <sub>CC(max)</sub> = 200 A, I <sub>OUT</sub> = 20 A	-6.5%		6.5%	
		4-phase, I <sub>CC(max)</sub> = 200 A, I <sub>OUT</sub> = 40 A	-3.7%		3.7%	
		4-phase, I <sub>CC(max)</sub> = 200 A, I <sub>OUT</sub> = 60 A	-2.8%		2.8%	
		4-phase, I <sub>CC(max)</sub> = 200 A, I <sub>OUT</sub> = 80 A	-2.3%		2.3%	
		4-phase, I <sub>CC(max)</sub> = 200 A, I <sub>OUT</sub> = 100 A	-2.1%		2.1%	
		4-phase, I <sub>CC(max)</sub> = 200 A, I <sub>OUT</sub> = 120 A	-1.9%		1.9%	
		4-phase, I <sub>CC(max)</sub> = 200 A, I <sub>OUT</sub> = 200 A	-1.5%		1.5%	
I <sub>MON_ACC</sub>	Digital current monitor accuracy, Rail B (READ_IOUT)	3-phase, I <sub>CC(max)</sub> = 82 A, I <sub>OUT</sub> = 8.2 A	-11.4%		11.4%	
		3-phase, I <sub>CC(max)</sub> = 82 A, I <sub>OUT</sub> = 16.4 A	-6.1%		6.1%	
		3-phase, I <sub>CC(max)</sub> = 82 A, I <sub>OUT</sub> = 24.6 A	-4.6%		4.6%	
		3-phase, I <sub>CC(max)</sub> = 82 A, I <sub>OUT</sub> = 32.8 A	-3.4%		3.4%	
		3-phase, I <sub>CC(max)</sub> = 82 A, I <sub>OUT</sub> = 41 A	-3%		3%	
		3-phase, I <sub>CC(max)</sub> = 82 A, I <sub>OUT</sub> = 49.2 A	-2.8%		2.8%	
		3-phase, I <sub>CC(max)</sub> = 82 A, I <sub>OUT</sub> = 82 A	-2%		2%	
I <sub>MON_ACC</sub>	Digital current monitor accuracy, Rail B (READ_IOUT)	2-phase, I <sub>CC(max)</sub> = 82 A, I <sub>OUT</sub> = 8.2 A	-8.7%		8.7%	
		2-phase, I <sub>CC(max)</sub> = 82 A, I <sub>OUT</sub> = 16.4 A	-4.7%		4.7%	
		2-phase, I <sub>CC(max)</sub> = 82 A, I <sub>OUT</sub> = 24.6 A	-3.7%		3.7%	
		2-phase, I <sub>CC(max)</sub> = 82 A, I <sub>OUT</sub> = 32.8 A	-2.7%		2.7%	
		2-phase, I <sub>CC(max)</sub> = 82 A, I <sub>OUT</sub> = 41 A	-2.5%		2.5%	
		2-phase, I <sub>CC(max)</sub> = 82 A, I <sub>OUT</sub> = 49.2 A	-2.4%		2.4%	
		2-phase, I <sub>CC(max)</sub> = 82 A, I <sub>OUT</sub> = 82 A	-1.8%		1.8%	
Temp	READ_TEMP1	0.28 V (-40°C) ≤ TSEN ≤ 1.8 V (150°C)	-2	0	2	°C

## 6.9 Input Current Sensing

over recommended operating conditions (unless otherwise noted)

PARAMETER		TEST CONDITIONS	MIN	TYP	MAX	UNIT
I <sub>IN</sub>	READ_IIN accuracy	(V <sub>CSPIN</sub> – V <sub>CSNIN</sub> ) = 2.5 mV, I <sub>IN</sub> = 5 A, R <sub>SENSE</sub> = 0.5 mΩ	-10%		10%	
		(V <sub>CSPIN</sub> – V <sub>CSNIN</sub> ) = 5 mV, I <sub>IN</sub> = 10 A, R <sub>SENSE</sub> = 0.5 mΩ	-6%		6%	
		(V <sub>CSPIN</sub> – V <sub>CSNIN</sub> ) = 15 mV, I <sub>IN</sub> = 30 A, R <sub>SENSE</sub> = 0.5 mΩ	-3%		3%	

## 6.10 Programmable Loadline Settings

over recommended operating conditions (unless otherwise noted)

PARAMETER	TEST CONDITIONS	MIN	TYP	MAX	UNIT
DCLL <sub>Channel A</sub>	DC loadline settings for Channel A				
	VOUT_DROOP = 0xD000		0		mΩ
	VOUT_DROOP = 0xD008	0.1125	0.125	0.1395	mΩ
	VOUT_DROOP = 0xD010	0.2412	0.25	0.2587	mΩ
	VOUT_DROOP = 0xD014	0.3031	0.3125	0.3218	mΩ
	VOUT_DROOP = 0xD018	0.3637	0.375	0.3872	mΩ
	VOUT_DROOP = 0xD01C	0.4265	0.4375	0.4484	mΩ
	VOUT_DROOP = 0xD020	0.4875	0.5	0.5125	mΩ
	VOUT_DROOP = 0xD024	0.5484	0.5625	0.5765	mΩ
	VOUT_DROOP = 0xD028	0.6093	0.625	0.6406	mΩ
	VOUT_DROOP = 0xD030	0.6855	0.7031	0.7207	mΩ
	VOUT_DROOP = 0xD033	0.7769	0.7969	0.8168	mΩ
	VOUT_DROOP = 0xD034	0.7921	0.8125	0.8328	mΩ
	VOUT_DROOP = 0xD035	0.8073	0.8281	0.8488	mΩ
	VOUT_DROOP = 0xD036	0.8227	0.8438	0.8648	mΩ
	VOUT_DROOP = 0xD037	0.8379	0.8594	0.8808	mΩ
	VOUT_DROOP = 0xD038	0.8531	0.875	0.8968	mΩ
	VOUT_DROOP = 0xD039	0.8683	0.8906	0.9128	mΩ
	VOUT_DROOP = 0xD03A	0.8836	0.9063	0.9289	mΩ
	VOUT_DROOP = 0xD03B	0.8988	0.9219	0.9449	mΩ
	VOUT_DROOP = 0xD03C	0.9140	0.9375	0.9609	mΩ
	VOUT_DROOP = 0xD03D	0.9292	0.9531	0.9769	mΩ
	VOUT_DROOP = 0xD03E	0.9445	0.9688	0.9930	mΩ
	VOUT_DROOP = 0xD03F	0.9597	0.9844	1.0090	mΩ
	VOUT_DROOP = 0xD040	0.975	1	1.025	mΩ
	VOUT_DROOP = 0xD041	0.9902	1.0156	1.0409	mΩ
	VOUT_DROOP = 0xD042	1.0055	1.0313	1.0570	mΩ
	VOUT_DROOP = 0xD043	1.0207	1.0469	1.0730	mΩ
	VOUT_DROOP = 0xD044	1.0359	1.0625	1.0890	mΩ
	VOUT_DROOP = 0xD048	1.0968	1.125	1.1531	mΩ
	VOUT_DROOP = 0xD050	1.2187	1.25	1.2812	mΩ
	VOUT_DROOP = 0xD058	1.3406	1.375	1.4093	mΩ
	VOUT_DROOP = 0xD060	1.4625	1.5	1.5375	mΩ
	VOUT_DROOP = 0xD068	1.5843	1.625	1.6656	mΩ
	VOUT_DROOP = 0xD070	1.7062	1.75	1.7937	mΩ
	VOUT_DROOP = 0xD078	1.8281	1.875	1.9218	mΩ
VOUT_DROOP = 0xD07C	1.8890	1.9375	1.9859	mΩ	
VOUT_DROOP = 0xD080	1.95	2	2.05	mΩ	
VOUT_DROOP = 0xD084	2.0109	2.0625	2.1141	mΩ	
VOUT_DROOP = 0xD088	2.0718	2.125	2.1781	mΩ	
VOUT_DROOP = 0xD08C	2.1328	2.1875	2.2421	mΩ	
VOUT_DROOP = 0xD090	2.1937	2.25	2.3062	mΩ	
VOUT_DROOP = 0xD098	2.2698	2.328	2.3862	mΩ	
VOUT_DROOP = 0xD09B	2.3612	2.4218	2.4823	mΩ	
VOUT_DROOP = 0xD09C	2.3765	2.4375	2.4984	mΩ	

**Programmable Loadline Settings (continued)**

over recommended operating conditions (unless otherwise noted)

PARAMETER		TEST CONDITIONS	MIN	TYP	MAX	UNIT
DCLL <sub>Channel A</sub>	DC loadline settings for Channel A	VOUT_DROOP = 0xD09D	2.3917	2.4531	2.5144	mΩ
		VOUT_DROOP = 0xD09E	2.4069	2.4687	2.5304	mΩ
		VOUT_DROOP = 0xD09F	2.4221	2.4843	2.5464	mΩ
		VOUT_DROOP = 0xD0A0	2.4375	2.5	2.5625	mΩ
		VOUT_DROOP = 0xD0A1	2.4527	2.5156	2.5784	mΩ
		VOUT_DROOP = 0xD0A2	2.4679	2.5312	2.5944	mΩ
		VOUT_DROOP = 0xD0A3	2.4831	2.5468	2.6104	mΩ
		VOUT_DROOP = 0xD0A4	2.4984	2.5625	2.6265	mΩ
		VOUT_DROOP = 0xD0A5	2.5136	2.5781	2.6425	mΩ
		VOUT_DROOP = 0xD0A6	2.5288	2.5937	2.6585	mΩ
		VOUT_DROOP = 0xD0A7	2.5437	2.609	2.6742	mΩ
		VOUT_DROOP = 0xD0A8	2.5593	2.625	2.6906	mΩ
		VOUT_DROOP = 0xD0A9	2.5745	2.6406	2.7066	mΩ
		VOUT_DROOP = 0xD0AA	2.5897	2.6562	2.7226	mΩ
		VOUT_DROOP = 0xD0AB	2.6050	2.6718	2.7385	mΩ
		VOUT_DROOP = 0xD0AC	2.6203	2.6875	2.7546	mΩ
		VOUT_DROOP = 0xD0B0	2.6812	2.75	2.8187	mΩ
		VOUT_DROOP = 0xD0B8	2.8031	2.875	2.9468	mΩ
VOUT_DROOP = 0xD0C0	2.925	3	3.075	mΩ		
VOUT_DROOP = 0xD0C8	3.0468	3.125	3.2031	mΩ		
DCLL <sub>Channel B</sub>	DC Loadline settings for Channel B	VOUT_DROOP = 0xD000		0		mΩ
		VOUT_DROOP = 0xD008	0.1125	0.125	0.1395	mΩ
		VOUT_DROOP = 0xD010	0.2355	0.25	0.2625	mΩ
		VOUT_DROOP = 0xD014	0.297	0.3125	0.3234	mΩ
		VOUT_DROOP = 0xD018	0.3637	0.375	0.395	mΩ
		VOUT_DROOP = 0xD01C	0.4244	0.4375	0.454	mΩ
		VOUT_DROOP = 0xD020	0.4875	0.5	0.517	mΩ
		VOUT_DROOP = 0xD024	0.5464	0.5625	0.5786	mΩ
		VOUT_DROOP = 0xD028	0.6093	0.625	0.648	mΩ
		VOUT_DROOP = 0xD030	0.6855	0.7031	0.7207	mΩ
		VOUT_DROOP = 0xD033	0.7769	0.7969	0.8168	mΩ
		VOUT_DROOP = 0xD034	0.7921	0.8125	0.8335	mΩ
		VOUT_DROOP = 0xD035	0.8073	0.8281	0.852	mΩ
		VOUT_DROOP = 0xD036	0.8227	0.8438	0.8648	mΩ
		VOUT_DROOP = 0xD037	0.8379	0.8594	0.8815	mΩ
VOUT_DROOP = 0xD038	0.8531	0.875	0.8968	mΩ		

**Programmable Loadline Settings (continued)**

over recommended operating conditions (unless otherwise noted)

PARAMETER		TEST CONDITIONS	MIN	TYP	MAX	UNIT
ACLL	AC Loadline settings for both Channel A and Channel B <sup>(1)</sup>	MFR_SPECIFIC_07 = 0x00		0		mΩ
		MFR_SPECIFIC_07 = 0x01	0.1125	0.125	0.1395	mΩ
		MFR_SPECIFIC_07 = 0x02	0.2412	0.25	0.2587	mΩ
		MFR_SPECIFIC_07 = 0x03	0.3031	0.3125	0.3218	mΩ
		MFR_SPECIFIC_07 = 0x04	0.3637	0.375	0.3862	mΩ
		MFR_SPECIFIC_07 = 0x05	0.4265	0.4375	0.4484	mΩ
		MFR_SPECIFIC_07 = 0x06	0.4875	0.5	0.5125	mΩ
		MFR_SPECIFIC_07 = 0x07	0.5484	0.5625	0.5765	mΩ
		MFR_SPECIFIC_07 = 0x08	0.6093	0.625	0.6406	mΩ
		MFR_SPECIFIC_07 = 0x09	0.7312	0.75	0.7687	mΩ
		MFR_SPECIFIC_07 = 0x0A	0.7769	0.7969	0.8168	mΩ
		MFR_SPECIFIC_07 = 0x0B	0.7921	0.8125	0.8328	mΩ
		MFR_SPECIFIC_07 = 0x0C	0.8073	0.8281	0.8488	mΩ
		MFR_SPECIFIC_07 = 0x0D	0.8227	0.8438	0.8648	mΩ
		MFR_SPECIFIC_07 = 0x0E	0.8379	0.8594	0.8808	mΩ
		MFR_SPECIFIC_07 = 0x0F	0.8531	0.875	0.8968	mΩ
		MFR_SPECIFIC_07 = 0x10	0.8683	0.8906	0.9128	mΩ
		MFR_SPECIFIC_07 = 0x11	0.8836	0.9063	0.9289	mΩ
		MFR_SPECIFIC_07 = 0x12	0.8988	0.9219	0.9449	mΩ
		MFR_SPECIFIC_07 = 0x13	0.9140	0.9375	0.9609	mΩ
		MFR_SPECIFIC_07 = 0x14	0.9292	0.9531	0.9769	mΩ
		MFR_SPECIFIC_07 = 0x15	0.9445	0.9688	0.9930	mΩ
		MFR_SPECIFIC_07 = 0x16	0.9597	0.9844	1.0090	mΩ
		MFR_SPECIFIC_07 = 0x17	0.975	1	1.025	mΩ
		MFR_SPECIFIC_07 = 0x18	0.9902	1.0156	1.0409	mΩ
		MFR_SPECIFIC_07 = 0x19	1.0055	1.0313	1.0570	mΩ
		MFR_SPECIFIC_07 = 0x1A	1.0207	1.0469	1.0730	mΩ
		MFR_SPECIFIC_07 = 0x1B	1.0359	1.0625	1.0890	mΩ
		MFR_SPECIFIC_07 = 0x1C	1.0968	1.125	1.1531	mΩ
		MFR_SPECIFIC_07 = 0x1D	1.2187	1.25	1.2812	mΩ
		MFR_SPECIFIC_07 = 0x1E	1.3406	1.375	1.4093	mΩ
		MFR_SPECIFIC_07 = 0x1F	1.4625	1.5	1.5375	mΩ
MFR_SPECIFIC_07 = 0x20	1.5843	1.625	1.6656	mΩ		
MFR_SPECIFIC_07 = 0x21	1.7062	1.75	1.7937	mΩ		
MFR_SPECIFIC_07 = 0x22	1.8281	1.875	1.9218	mΩ		
MFR_SPECIFIC_07 = 0x23	1.8890	1.9375	1.9859	mΩ		
MFR_SPECIFIC_07 = 0x24	1.95	2	2.05	mΩ		
MFR_SPECIFIC_07 = 0x25	2.0109	2.0625	2.1140	mΩ		
MFR_SPECIFIC_07 = 0x26	2.0718	2.125	2.1781	mΩ		
MFR_SPECIFIC_07 = 0x27	2.1328	2.1875	2.2421	mΩ		
MFR_SPECIFIC_07 = 0x28	2.1937	2.25	2.3062	mΩ		
MFR_SPECIFIC_07 = 0x29	2.3156	2.375	2.4343	mΩ		
MFR_SPECIFIC_07 = 0x2A	2.3612	2.4218	2.4823	mΩ		
MFR_SPECIFIC_07 = 0x2B	2.3765	2.4375	2.4984	mΩ		

(1) Specified by design. Not production tested.

**Programmable Loadline Settings (continued)**

over recommended operating conditions (unless otherwise noted)

PARAMETER		TEST CONDITIONS	MIN	TYP	MAX	UNIT
ACLL	AC Loadline settings for both Channel A and Channel B <sup>(1)</sup>	MFR_SPECIFIC_07 = 0x2C	2.3917	2.4531	2.5144	mΩ
		MFR_SPECIFIC_07 = 0x2D	2.4069	2.4687	2.5304	mΩ
		MFR_SPECIFIC_07 = 0x2E	2.4221	2.4843	2.5464	mΩ
		MFR_SPECIFIC_07 = 0x2F	2.4375	2.5	2.5625	mΩ
		MFR_SPECIFIC_07 = 0x30	2.4527	2.5156	2.5784	mΩ
		MFR_SPECIFIC_07 = 0x31	2.4679	2.5312	2.5944	mΩ
		MFR_SPECIFIC_07 = 0x32	2.4831	2.5468	2.6104	mΩ
		MFR_SPECIFIC_07 = 0x33	2.4984	2.5625	2.6265	mΩ
		MFR_SPECIFIC_07 = 0x34	2.5136	2.5781	2.6425	mΩ
		MFR_SPECIFIC_07 = 0x35	2.5288	2.5937	2.6585	mΩ
		MFR_SPECIFIC_07 = 0x36	2.5437	2.609	2.6742	mΩ
		MFR_SPECIFIC_07 = 0x37	2.5593	2.625	2.6906	mΩ
		MFR_SPECIFIC_07 = 0x38	2.5745	2.6406	2.7066	mΩ
		MFR_SPECIFIC_07 = 0x39	2.5897	2.6562	2.7226	mΩ
		MFR_SPECIFIC_07 = 0x3A	2.6050	2.6718	2.7385	mΩ
		MFR_SPECIFIC_07 = 0x3B	2.6203	2.6875	2.7546	mΩ
		MFR_SPECIFIC_07 = 0x3C	2.6812	2.75	2.8187	mΩ
		MFR_SPECIFIC_07 = 0x3D	2.8031	2.875	2.9468	mΩ
			MFR_SPECIFIC_07 = 0x3E	2.925	3	3.075
	MFR_SPECIFIC_07 = 0x3F	3.0468	3.125	3.2031	mΩ	
t <sub>INT</sub>	Integration time constant <sup>(1)</sup>	MFR_SPEC_7<11:8> = 0000b		5		μs
		MFR_SPEC_7<11:8> = 0001b		10		μs
		MFR_SPEC_7<11:8> = 0010b		15		μs
		MFR_SPEC_7<11:8> = 0011b		20		μs
		MFR_SPEC_7<11:8> = 0100b		25		μs
		MFR_SPEC_7<11:8> = 0101b		30		μs
		MFR_SPEC_7<11:8> = 0110b		35		μs
		MFR_SPEC_7<11:8> = 0111b		40		μs
		MFR_SPEC_7<11:8> = 1000b		1		μs
		MFR_SPEC_7<11:8> = 1001b		2		μs
		MFR_SPEC_7<11:8> = 1010b		3		μs
		MFR_SPEC_7<11:8> = 1011b		4		μs
		MFR_SPEC_7<11:8> = 1100b		5		μs
		MFR_SPEC_7<11:8> = 1101b		6		μs
		MFR_SPEC_7<11:8> = 1110b		7		μs
		MFR_SPEC_7<11:8> = 1111b		8		μs

## 6.11 Current Sense and Calibration

over recommended operating conditions (unless otherwise noted)

PARAMETER		TEST CONDITIONS	MIN	TYP	MAX	UNIT
$I_{ACSP1}$	ACSP1 leakage current	$V_{ACSP1} = 2.5\text{ V}$	0		20	$\mu\text{A}$
$I_{ACSP2}$	ACSP2 leakage current	$V_{ACSP2} = 2.5\text{ V}$	0		20	$\mu\text{A}$
$I_{ACSP3}$	ACSP3 leakage current	$V_{ACSP3} = 2.5\text{ V}$	0		20	$\mu\text{A}$
$I_{ACSP4}$	ACSP4 leakage current	$V_{ACSP4} = 2.5\text{ V}$	0		20	$\mu\text{A}$
$I_{ACSP5}$	ACSP5 leakage current	$V_{ACSP5} = 2.5\text{ V}$	0		20	$\mu\text{A}$
$I_{ACSP6}$	ACSP6 leakage current	$V_{ACSP6} = 2.5\text{ V}$	0		20	$\mu\text{A}$
$I_{BCSP1}$	BCSP1 leakage current	$V_{BCSP1} = 2.5\text{ V}$	0		20	$\mu\text{A}$
$I_{BCSP2}$	BCSP2 leakage current	$V_{BCSP2} = 2.5\text{ V}$	0		20	$\mu\text{A}$
$I_{MON\_CAL\_OF1}$	Current monitor calibration offset LSB (per-phase) <sup>(1)</sup>	IOUT_CAL_OFFSET resolution (per-phase)		0.125		A
$I_{MON\_CAL\_OF2}$	Current monitor calibration offset range (per-phase)	IOUT_CAL_OFFSET = 0xE808 (per-phase)		1		A
		IOUT_CAL_OFFSET = 0xEFF9 (per-phase)		-0.875		A
$I_{MON\_CAL\_OF3}$	Current monitor calibration offset LSB (total) <sup>(1)</sup>	IOUT_CAL_OFFSET resolution (total)		0.25		A
$I_{MON\_CAL\_OF4}$	Current monitor calibration offset range (total)	IOUT_CAL_OFFSET = 0xE820 (total)		4		A
		IOUT_CAL_OFFSET = 0xEFE2 (total)		-3.75		A
$I_{MON\_CAL\_GA\_LSB}$	Current monitor calibration gain LSB <sup>(1)</sup>	IOUT_CAL_GAIN resolution		0.3125%		
$I_{MON\_CAL\_GA\_RNG}$	Current monitor calibration gain range	IOUT_CAL_GAIN = 0xD131		4.7656		m $\Omega$
		IOUT_CAL_GAIN = 0xD150		5.25		m $\Omega$

(1) Specified by design. Not production tested.

## 6.12 Logic Interface Pins: AVR\_EN, AVR\_RDY, BVR\_EN, BVR\_RDY, RESET, VR\_FAULT, VR\_HOT

over recommended operating conditions (unless otherwise noted)

PARAMETER		TEST CONDITIONS	MIN	TYP	MAX	UNIT
$R_{RPGDL}$	Open-drain pulldown resistance	$V_{AVR\_RDY} = V_{BVR\_RDY} = V_{VR\_FAULT} = 0.45\text{ V}$		36	50	$\Omega$
$I_{VRTTLK}$	Open-drain leakage current	SDIO, VR_HOT, AVR_RDY, BVR_RDY, VR_FAULT, Hi Z Leakage, apply to 3.3-V supply in off state	-2	0.2	2	$\mu\text{A}$
$V_{AENL}$	Channel A ENABLE logic low				0.7	V
$V_{AENH}$	Channel A ENABLE logic high		0.8			V
$V_{AENHYS}$	Channel A ENABLE hysteresis		0.028	0.05	0.07	V
$t_{AENDIG}$	Channel A ENABLE deglitch <sup>(1)</sup>		0.2			$\mu\text{s}$
$I_{AENH}$	Channel A I/O 1.1-V leakage	$V_{AVR\_EN} = 1.1\text{ V}$			25	$\mu\text{A}$
$V_{BENL}$	Channel B ENABLE logic low				0.7	V
$V_{BENH}$	Channel B ENABLE logic high		0.8			V
$V_{BENHYS}$	Channel B ENABLE hysteresis		0.028	0.05	0.07	V
$t_{BENDIG}$	Channel B ENABLE deglitch <sup>(1)</sup>		0.2			$\mu\text{s}$
$t_{AENVRDYF}$	Channel A ENABLE low to AVR_RDY low	From AVR_EN low to AVR_RDY low			1.5	$\mu\text{s}$
$I_{BENH}$	Channel B I/O 1.1-V leakage	$V_{BENH} = 1.1\text{ V}$			25	$\mu\text{A}$
$V_{RSTL}$	RESET logic low				0.8	V
$V_{RSTH}$	RESET logic high <sup>(1)</sup>		1.09			V
$t_{RSTTDLY}$	RESET delay time			1		$\mu\text{s}$

(1) Specified by design. Not production tested.

### 6.13 I/O Timing

over recommended operating conditions (unless otherwise noted)

PARAMETER		TEST CONDITIONS	MIN	TYP	MAX	UNIT
t <sub>STARTUPA</sub>	Channel A startup time <sup>(1)</sup>	V <sub>BOOT</sub> > 0 V, no faults, C <sub>REF</sub> = 1 μF, TON_DELAY = 0xB1EC (PAGE 0)	0.38	0.48	0.58	ms
		TON_DELAY = 0xB396 (PAGE 0)	0.8	0.9	1	ms
		TON_DELAY = 0xBAD1 (PAGE 0)	1.308	1.408	1.508	ms
		TON_DELAY = 0xC26E (PAGE 0)	2.28	2.432	2.584	ms
		TON_DELAY = others	Invalid			
t <sub>STARTUPB</sub>	Channel B startup time <sup>(2)</sup>	V <sub>BOOT</sub> > 0 V, no faults, C <sub>REF</sub> = 1 μF, TON_DELAY = 0xB1EC (PAGE 1)	0.38	0.48	0.58	ms
		TON_DELAY = 0xB396 (PAGE 1)	0.8	0.9	1	ms
		TON_DELAY = 0xBAD1 (PAGE 1)	1.308	1.408	1.508	ms
		TON_DELAY = 0xC26E (PAGE 1)	2.28	2.432	2.584	ms
		TON_DELAY = others	Invalid			
t <sub>VCCVID</sub>	VID change to VSP change <sup>(3)</sup>	ACK of SetVID_x command to start of voltage ramp			500	ns
t <sub>VRTDGLT</sub>	$\overline{VR\_HOT}$ update time	Temperature data update time		0.3	0.5	ms
t <sub>ON_BLANK</sub>	Rising-edge blanking time <sup>(3)</sup>	MFR_SPEC_09<8:6> = 000b	53	72	92	ns
		MFR_SPEC_09<8:6> = 001b	58	78	98	ns
		MFR_SPEC_09<8:6> = 010b	66	86	108	ns
		MFR_SPEC_09<8:6> = 011b	70	92	114	ns
		MFR_SPEC_09<8:6> = 100b	78	100	125	ns
		MFR_SPEC_09<8:6> = 101b	82	108	132	ns
		MFR_SPEC_09<8:6> = 110b	88	114	139	ns
		MFR_SPEC_09<8:6> = 111b	91	120	145	ns

- (1) Time from AVR\_EN to output voltage ramp up to target voltage.  
 (2) Time from AVR\_EN or BVR\_EN to output voltage ramp up to target voltage.  
 (3) Specified by design. Not production tested.

## 6.14 PMBus Address Setting

over recommended operating conditions (unless otherwise noted)

PARAMETER		TEST CONDITIONS	MIN	TYP	MAX	UNIT
P <sub>ADDR</sub>	PMBus address bits (7-bit format)	V <sub>ADDR</sub> ≤ 0.039 V		1011000 (B0h)		Bin
		V <sub>ADDR</sub> = 0.073 V with ±15 mV tolerance		1011001 (B2h)		Bin
		V <sub>ADDR</sub> = 0.122 V with ±15 mV tolerance		1011010 (B4h)		Bin
		V <sub>ADDR</sub> = 0.171 V with ±15 mV tolerance		1011011 (B6h)		Bin
		V <sub>ADDR</sub> = 0.219 V with ±15 mV tolerance		1011100 (B8h)		Bin
		V <sub>ADDR</sub> = 0.268 V with ±15 mV tolerance		1011101 (BAh)		Bin
		V <sub>ADDR</sub> = 0.317 V with ±15 mV tolerance		1011110 (BCh)		Bin
		V <sub>ADDR</sub> = 0.366 V with ±15 mV tolerance		1011111 (BEh)		Bin
		V <sub>ADDR</sub> = 0.415 V with ±15 mV tolerance		1100000 (C0h)		Bin
		V <sub>ADDR</sub> = 0.464 V with ±15 mV tolerance		1100001 (C2h)		Bin
		V <sub>ADDR</sub> = 0.513 V with ±15 mV tolerance		1100010 (C4h)		Bin
		V <sub>ADDR</sub> = 0.562 V with ±15 mV tolerance		1100011 (C6h)		Bin
		V <sub>ADDR</sub> = 0.610 V with ±15 mV tolerance		1100100 (C8h)		Bin
		V <sub>ADDR</sub> = 0.660 V with ±15 mV tolerance		1100101 (CAh)		Bin
		V <sub>ADDR</sub> = 0.708 V with ±15 mV tolerance		1100110 (CCh)		Bin
		V <sub>ADDR</sub> = 0.757 V with ±15 mV tolerance		1100111 (CEh)		Bin
		V <sub>ADDR</sub> = 0.806 V with ±15 mV tolerance		1101000 (D0h)		Bin
		V <sub>ADDR</sub> = 0.854 V with ±15 mV tolerance		1101001 (D2h)		Bin
		V <sub>ADDR</sub> = 0.903 V with ±15 mV tolerance		1101010 (D4h)		Bin
		V <sub>ADDR</sub> = 0.952 V with ±15 mV tolerance		1101011 (D6h)		Bin
		V <sub>ADDR</sub> = 1.000 V with ±15 mV tolerance		1101100 (D8h)		Bin
		V <sub>ADDR</sub> = 1.050 V with ±15 mV tolerance		1101101 (DAh)		Bin
		V <sub>ADDR</sub> = 1.098 V with ±15 mV tolerance		1101110 (DCh)		Bin
		V <sub>ADDR</sub> = 1.147 V with ±15 mV tolerance		1101111 (DEh)		Bin
		V <sub>ADDR</sub> = 1.196 V with ±15 mV tolerance		1110000 (E0h)		Bin
		V <sub>ADDR</sub> = 1.245 V with ±15 mV tolerance		1110001 (E2h)		Bin
		V <sub>ADDR</sub> = 1.294 V with ±15 mV tolerance		1110010 (E4h)		Bin
		V <sub>ADDR</sub> = 1.343 V with ±15 mV tolerance		1110011 (E6h)		Bin
		V <sub>ADDR</sub> = 1.392 V with ±15 mV tolerance		1110100 (E8h)		Bin
		V <sub>ADDR</sub> = 1.440 V with ±15 mV tolerance		1110101 (EAh)		Bin
V <sub>ADDR</sub> = 1.489 V with ±15 mV tolerance		1110110 (ECh)		Bin		
V <sub>ADDR</sub> = 1.540 V with ±15 mV tolerance		1110111 (EEh)		Bin		

## 6.15 Overcurrent Limit Thresholds

over recommended operating conditions (unless otherwise noted)

PARAMETER		TEST CONDITIONS	MIN	TYP	MAX	UNIT
$I_{OCLAx}$	Phase OCL levels for Channel A (ACSPx-VREF), valley current limit	MFR_SPEC_00<3:0>, (PAGE0) = 0000b	12.5	14.5	16.5	A
		MFR_SPEC_00<3:0>, (PAGE0) = 0001b	16.5	18.5	20.5	A
		MFR_SPEC_00<3:0>, (PAGE0) = 0010b	20.5	22.5	24.5	A
		MFR_SPEC_00<3:0>, (PAGE0) = 0011b	24.5	26.5	28.5	A
		MFR_SPEC_00<3:0>, (PAGE0) = 0100b	28.5	30.5	32.5	A
		MFR_SPEC_00<3:0>, (PAGE0) = 0101b	32.5	34.5	36.5	A
		MFR_SPEC_00<3:0>, (PAGE0) = 0110b	36.5	38.5	40.5	A
		MFR_SPEC_00<3:0>, (PAGE0) = 0111b	40.5	42.5	44.5	A
		MFR_SPEC_00<3:0>, (PAGE0) = 1000b	44.5	46.5	48.5	A
		MFR_SPEC_00<3:0>, (PAGE0) = 1001b	48.5	50.5	52.5	A
		MFR_SPEC_00<3:0>, (PAGE0) = 1010b	52.5	54.5	56.5	A
		MFR_SPEC_00<3:0>, (PAGE0) = 1011b	56.5	58.5	60.5	A
		MFR_SPEC_00<3:0>, (PAGE0) = 1100b	60.5	62.5	64.5	A
		MFR_SPEC_00<3:0>, (PAGE0) = 1101b	64.5	66.5	68.5	A
		MFR_SPEC_00<3:0>, (PAGE0) = 1110b	68.5	70.5	72.5	A
		MFR_SPEC_00<3:0>, (PAGE0) = 1111b	72.5	74.5	76.5	A
$I_{OCLBx}$	Phase OCL levels for Channel B (BCSPx-VREF), valley current limit	MFR_SPEC_00<3:0>, (PAGE1) = 0000b	12	14	16	A
		MFR_SPEC_00<3:0>, (PAGE1) = 0001b	16	18	20	A
		MFR_SPEC_00<3:0>, (PAGE1) = 0010b	20	22	24	A
		MFR_SPEC_00<3:0>, (PAGE1) = 0011b	24	26	28	A
		MFR_SPEC_00<3:0>, (PAGE1) = 0100b	28	30	32	A
		MFR_SPEC_00<3:0>, (PAGE1) = 0101b	32	34	36	A
		MFR_SPEC_00<3:0>, (PAGE1) = 0110b	36	38	40	A
		MFR_SPEC_00<3:0>, (PAGE1) = 0111b	40	42	44	A
		MFR_SPEC_00<3:0>, (PAGE1) = 1000b	44	46	48	A
		MFR_SPEC_00<3:0>, (PAGE1) = 1001b	48	50	52	A
		MFR_SPEC_00<3:0>, (PAGE1) = 1010b	52	54	56	A
		MFR_SPEC_00<3:0>, (PAGE1) = 1011b	56	58	60	A
		MFR_SPEC_00<3:0>, (PAGE1) = 1100b	60	62	64	A
		MFR_SPEC_00<3:0>, (PAGE1) = 1101b	64	66	68	A
		MFR_SPEC_00<3:0>, (PAGE1) = 1110b	68	70	72	A
		MFR_SPEC_00<3:0>, (PAGE1) = 1111b	72	74	76	A

## 6.16 Switching Frequency

 $V_{IN} = 12\text{ V}$ ,  $V_{AVSP} = 1.0\text{ V}$ ,  $V_{BVSP} = 0.8\text{ V}$ ,  $T_A = 25^\circ\text{C}$ 

PARAMETER		TEST CONDITIONS	MIN	TYP	MAX	UNIT
f <sub>SW</sub>	Switching frequency	FREQUENCY_SWITCH = 0x012C	270	300	330	kHz
		FREQUENCY_SWITCH = 0x015E	315	350	385	kHz
		FREQUENCY_SWITCH = 0x0190	360	400	440	kHz
		FREQUENCY_SWITCH = 0x01C2	405	450	495	kHz
		FREQUENCY_SWITCH = 0x01F4	450	500	550	kHz
		FREQUENCY_SWITCH = 0x0226	500	550	600	kHz
		FREQUENCY_SWITCH = 0x0258	540	600	660	kHz
		FREQUENCY_SWITCH = 0x028A	585	650	715	kHz
		FREQUENCY_SWITCH = 0x02BC	630	700	770	kHz
		FREQUENCY_SWITCH = 0x02EE	675	750	825	kHz
		FREQUENCY_SWITCH = 0x0320	720	800	880	kHz
		FREQUENCY_SWITCH = 0x0352	765	850	935	kHz
		FREQUENCY_SWITCH = 0x0384	810	900	990	kHz
		FREQUENCY_SWITCH = 0x03B6	855	950	1045	kHz
		FREQUENCY_SWITCH = 0x03E8	900	1000	1100	kHz
	FREQUENCY_SWITCH = others		Invalid		kHz	

## 6.17 Slew Rate Settings

over recommended operating conditions (unless otherwise noted)

PARAMETER		TEST CONDITIONS	MIN	TYP	MAX	UNIT
SL <sub>SET</sub>	Slew rate setting	VOUT_TRANSITION_RATE = 0xE050	5	6	7	mV/μs
		VOUT_TRANSITION_RATE = 0xE0A0	10	12	14	mV/μs
		VOUT_TRANSITION_RATE = 0xE0F0	15	18		mV/μs
		VOUT_TRANSITION_RATE = 0xE140	20	24		mV/μs
		VOUT_TRANSITION_RATE = 0xE190	25	30		mV/μs
		VOUT_TRANSITION_RATE = 0xE1E0	30	36		mV/μs
		VOUT_TRANSITION_RATE = 0xE230	35	42		mV/μs
		VOUT_TRANSITION_RATE = 0xE280	40	48		mV/μs
		VOUT_TRANSITION_RATE = 0xE005	0.3125			mV/μs
		VOUT_TRANSITION_RATE = 0xE00A	0.625			mV/μs
		VOUT_TRANSITION_RATE = 0xE00F	0.9375			mV/μs
		VOUT_TRANSITION_RATE = 0xE014	1.25			mV/μs
		VOUT_TRANSITION_RATE = 0xE019	1.5625			mV/μs
		VOUT_TRANSITION_RATE = 0xE01E	1.875			mV/μs
		VOUT_TRANSITION_RATE = 0xE023	2.1875			mV/μs
		VOUT_TRANSITION_RATE = 0xE028	2.5			mV/μs
	VOUT_TRANSITION_RATE = others		Invalid data		mV/μs	
SL <sub>F</sub>	AVSP and BVSP slew rate SetVID_Fast			SL <sub>SET</sub>	mV/μs	
SL <sub>S1</sub>	AVSP and BVSP slew rate slow			SL <sub>SET</sub> / 4	mV/μs	
				SL <sub>SET</sub> / 2	mV/μs	
SL <sub>SS</sub>	AVSP and BVSP slew rate slew rate soft-start	MFR_SPEC_13<8> = 0b		SL <sub>SET</sub> / 4	mV/μs	
		MFR_SPEC_13<8> = 1b		SL <sub>SET</sub> / 16	mV/μs	

## 6.18 Ramp Selections

over recommended operating conditions (unless otherwise noted)

PARAMETER		TEST CONDITIONS	MIN	TYP	MAX	UNIT
V <sub>RAMP</sub>	RAMP Setting	MFR_SPEC_14<2:0> = 000b	30	40	55	mV
		MFR_SPEC_14<2:0> = 001b	70	80	95	mV
		MFR_SPEC_14<2:0> = 010b	110	120	135	mV
		MFR_SPEC_14<2:0> = 011b	150	160	175	mV
		MFR_SPEC_14<2:0> = 100b	190	200	215	mV
		MFR_SPEC_14<2:0> = 101b	230	240	255	mV
		MFR_SPEC_14<2:0> = 110b	270	280	300	mV
		MFR_SPEC_14<2:0> = 111b	305	320	335	mV

## 6.19 Dynamic Integration and Undershoot Reduction

 T<sub>A</sub> = 25°C (unless otherwise noted)

PARAMETER		TEST CONDITIONS	MIN	TYP	MAX	UNIT
V <sub>DYN</sub>	Dynamic integration voltage setting	MFR_SPEC_12<10:8> = 000b;	90	100	116	mV
		MFR_SPEC_12<10:8> = 001b;	135	150	175	mV
		MFR_SPEC_12<10:8> = 010b;	175	200	230	mV
		MFR_SPEC_12<10:8> = 011b;	225	250	285	mV
		MFR_SPEC_12<10:8> = 100b;	270	300	345	mV
		MFR_SPEC_12<10:8> = 101b;	315	350	400	mV
		MFR_SPEC_12<10:8> = 110b;	360	400	455	mV
		MFR_SPEC_12<10:8> = 111b;		OFF		mV
t <sub>DINT</sub>	Dynamic integration time constant <sup>(1)</sup>	MFR_SPEC_12<7:4> = 0000b;		1		μs
		MFR_SPEC_12<7:4> = 0001b;		2		μs
		MFR_SPEC_12<7:4> = 0010b;		3		μs
		MFR_SPEC_12<7:4> = 0011b;		4		μs
		MFR_SPEC_12<7:4> = 0100b;		5		μs
		MFR_SPEC_12<7:4> = 0101b;		6		μs
		MFR_SPEC_12<7:4> = 0110b;		7		μs
		MFR_SPEC_12<7:4> = 0111b;		8		μs
		MFR_SPEC_12<7:4> = 1000b;		12		μs
		MFR_SPEC_12<7:4> = 1001b;		13		μs
		MFR_SPEC_12<7:4> = 1010b;		14		μs
		MFR_SPEC_12<7:4> = 1011b;		15		μs
		MFR_SPEC_12<7:4> = 1100b;		16		μs
		MFR_SPEC_12<7:4> = 1101b;		17		μs
		MFR_SPEC_12<7:4> = 1110b;		18		μs
		MFR_SPEC_12<7:4> = 1111b;		19		μs
V <sub>USR2</sub>	USR level 2 voltage setting	MFR_SPEC_09<14:12> = 000b;	120	140	160	mV
		MFR_SPEC_09<14:12> = 001b;	155	180	205	mV
		MFR_SPEC_09<14:12> = 010b;	190	220	245	mV
		MFR_SPEC_09<14:12> = 011b;	230	260	290	mV
		MFR_SPEC_09<14:12> = 100b;	265	300	335	mV
		MFR_SPEC_09<14:12> = 101b;	300	340	375	mV
		MFR_SPEC_09<14:12> = 110b;	335	380	420	mV
		MFR_SPEC_09<14:12> = 111b;		OFF		mV

(1) Specified by design. Not production tested.

## Dynamic Integration and Undershoot Reduction (continued)

 $T_A = 25^\circ\text{C}$  (unless otherwise noted)

PARAMETER		TEST CONDITIONS	MIN	TYP	MAX	UNIT
$V_{\text{USR1}}$	USR level 1 voltage setting	MFR_SPEC_09<2:0> = 000b;	70	90	110	mV
		MFR_SPEC_09<2:0> = 001b;	100	120	140	mV
		MFR_SPEC_09<2:0> = 010b;	130	150	170	mV
		MFR_SPEC_09<2:0> = 011b;	160	180	205	mV
		MFR_SPEC_09<2:0> = 100b;	185	210	240	mV
		MFR_SPEC_09<2:0> = 101b;	215	240	270	mV
		MFR_SPEC_09<2:0> = 110b;	240	270	305	mV
		MFR_SPEC_09<2:0> = 111b;		OFF		mV
$\text{PH}_{\text{USR1}}$	Maximum phase added in USR level 1 <sup>(1)</sup>	MFR_SPEC_09<5> = 0b;		3		phases
		MFR_SPEC_09<5> = 1b;		4		phases
$V_{\text{OUSRHYS}}$	Dynamic integration/USR voltage hysteresis	MFR_SPEC_09<4:3> = 00b;	2	5	9	mV
		MFR_SPEC_09<4:3> = 01b;	5	10	15	mV
		MFR_SPEC_09<4:3> = 10b;	10	15	20	mV
		MFR_SPEC_09<4:3> = 11b;	15	20	25	mV

## 6.20 Boot Voltage and TMAX Settings

over recommended operating conditions (unless otherwise noted)

PARAMETER		TEST CONDITIONS	MIN	TYP	MAX	UNIT
$T_{\text{MAX}}$	Maximum temperature setting	MFR_SPEC_12<2:0> = 000b		90		$^\circ\text{C}$
		MFR_SPEC_12<2:0> = 001b		95		$^\circ\text{C}$
		MFR_SPEC_12<2:0> = 010b		100		$^\circ\text{C}$
		MFR_SPEC_12<2:0> = 011b		105		$^\circ\text{C}$
		MFR_SPEC_12<2:0> = 100b		110		$^\circ\text{C}$
		MFR_SPEC_12<2:0> = 101b		115		$^\circ\text{C}$
		MFR_SPEC_12<2:0> = 110b		120		$^\circ\text{C}$
		MFR_SPEC_12<2:0> = 111b		125		$^\circ\text{C}$
$V_{\text{BOOT}}$	BOOT voltage setting (10-mV DAC)	MFR_SPEC_11<7:0> = 00h		0		V
		MFR_SPEC_11<7:0> = 74h		1.65		V
		MFR_SPEC_11<7:0> = 79h		1.7		V
		MFR_SPEC_11<7:0> = 7Eh		1.75		V
	BOOT voltage setting (5-mV DAC)	MFR_SPEC_11<7:0> = 00h		0		V
		MFR_SPEC_11<7:0> = 83h		0.9		V
		MFR_SPEC_11<7:0> = 97h		1		V
		MFR_SPEC_11<7:0> = BFh		1.2		V

## 6.21 Protections: OVP and UVP

over recommended operating conditions (unless otherwise noted)

PARAMETER		TEST CONDITIONS	MIN	TYP	MAX	UNIT
$V_{RDYH5}$	Tracking OVP	Measured at the VSP pin wrt VID code. Device latches OFF.	330		400	mV
$V_{RDYH0}$		Measured at the VSP pin wrt VID code. Device latches OFF.	140		200	mV
$t_{RDYDGLTO}$	VR_RDY deglitch time <sup>(1)</sup>				<sup>(2)</sup> 2.5	μs
$t_{RDYDGLTU}$	VR_RDY deglitch time <sup>(1)</sup>	$f_{SW} = 500$ kHz		4		μs
$V_{RDYL}$	Undervoltage protection <sup>(3)</sup>	( $V_{VSP} + V_{DROOP}$ ) with respect to VID	370	400	430	mV
$V_{OVPA}$	Fixed overvoltage protection, Channel A <sup>(3)</sup>	$V_{AVSP} > V_{OVP}$ for 1 μs, ENABLE = HI or LO, PWM to LO	2.75	2.8	2.86	V
$V_{OVPB}$	Fixed overvoltage protection, Channel B <sup>(3)</sup>	$V_{BVSP} > V_{OVP}$ for 1 μs, ENABLE = HI or LO, PWM to LO	1.85	1.9	1.95	V

(1) Specified by design. Not production tested.

(2) Time from VSP out of +200 or +400 mV VDAC boundary to VR\_RDY low.

(3) Can be programmed with different configurations.

## 6.22 Protections: ATSEN and BTSEN Pin Voltage Levels and Fault

over recommended operating conditions (unless otherwise noted)

PARAMETER		TEST CONDITIONS	MIN	TYP	MAX	UNIT
TSEN	Thermal voltage definition	$V_{TSEN} = 0.28$ V	–42	–40	–38	°C
		$V_{TSEN} = 0.8$ V	23	25	27	°C
		$V_{TSEN} = 1.2$ V	73	75	77	°C
		$V_{TSEN} = 1.4$ V	98	100	102	°C
		$V_{TSEN} = 1.6$ V	123	125	127	°C
		$V_{TSEN} = 1.8$ V	148	150	152	°C
$I_{TSEN}$	TSEN leakage current		–3		3	μA

## 6.23 PWM: I/O Voltage and Current

over recommended operating conditions (unless otherwise noted)

PARAMETER		TEST CONDITIONS	MIN	TYP	MAX	UNIT
V <sub>PWML</sub>	PWMx output low-level	I <sub>LOAD</sub> = 0.5 mA		0.15	0.3	V
V <sub>PWMH</sub>	PWMx output high-level	I <sub>LOAD</sub> = -0.5 mA; V <sub>V3P3</sub> = 2.97 V	2.8			V
V <sub>PW-SCLK</sub>	PWMx tri-state	I <sub>LOAD</sub> = ± 100 μA	1.6	1.7	1.8	V
t <sub>P-S_H-L</sub>	PWMx H-L transition time <sup>(1)</sup>	C <sub>LOAD</sub> = 10 pF, I <sub>LOAD</sub> = ± 100 μA, 10% to 90% both edges			10	ns
t <sub>P-S_TRI</sub>	PWMx tri-state transition <sup>(1)</sup>	C <sub>LOAD</sub> = 10 pF, I <sub>LOAD</sub> = ± 100 μA, 10% or 90% to tri-state, both edges			10	ns

(1) Specified by design. Not production tested.

## 6.24 Dynamic Phase Add and Drop

over recommended operating conditions (unless otherwise noted)

PARAMETER		TEST CONDITIONS	MIN	TYP	MAX	UNIT
V <sub>DPSTHA1</sub>	Dynamic phase adding threshold, 1 to 2 Phases (Peak Current)	Peak Efficiency = 12 A; (MFR_SPECIFIC_15<1:0> = 00b); Offset = 2 A; (MFR_SPECIFIC_15<4:3> = 00b); V <sub>RIPPLE</sub> ≈ 18 A (estimation)	21	23	25	A
		Peak Efficiency = 12 A; (MFR_SPECIFIC_15<1:0> = 00b); Offset = 4 A; (MFR_SPECIFIC_15<4:3> = 01b); V <sub>RIPPLE</sub> ≈ 18 A (estimation)	23	25	27	A
		Peak Efficiency = 12 A; (MFR_SPECIFIC_15<1:0> = 00b); Offset = 6 A; (MFR_SPECIFIC_15<4:3> = 10b); V <sub>RIPPLE</sub> ≈ 18 A (estimation)	25	27	29	A
		Peak Efficiency = 12 A; (MFR_SPECIFIC_15<1:0> = 00b); Offset = 8 A; (MFR_SPECIFIC_15<4:3> = 11b); V <sub>RIPPLE</sub> ≈ 18 A (estimation)	27	29	31	A
		Peak Efficiency = 14 A; (MFR_SPECIFIC_15<1:0> = 01b); Offset = 2 A; (MFR_SPECIFIC_15<4:3> = 00b); V <sub>RIPPLE</sub> ≈ 18 A (estimation)	23	25	27	A
		Peak Efficiency = 14 A; (MFR_SPECIFIC_15<1:0> = 01b); Offset = 4 A; (MFR_SPECIFIC_15<4:3> = 01b); V <sub>RIPPLE</sub> ≈ 18 A (estimation)	25	27	29	A
		Peak Efficiency = 14 A; (MFR_SPECIFIC_15<1:0> = 01b); Offset = 6 A; (MFR_SPECIFIC_15<4:3> = 10b); V <sub>RIPPLE</sub> ≈ 18 A (estimation)	27	29	31	A
		Peak Efficiency = 14 A; (MFR_SPECIFIC_15<1:0> = 01b); Offset = 8 A; (MFR_SPECIFIC_15<4:3> = 11b); V <sub>RIPPLE</sub> ≈ 18 A (estimation)	29	31	33	A
		Peak Efficiency = 16 A; (MFR_SPECIFIC_15<1:0> = 10b); Offset = 2 A; (MFR_SPECIFIC_15<4:3> = 00b); V <sub>RIPPLE</sub> ≈ 18 A (estimation)	25	27	29	A
		Peak Efficiency = 16 A; (MFR_SPECIFIC_15<1:0> = 10b); Offset = 4 A; (MFR_SPECIFIC_15<4:3> = 01b); V <sub>RIPPLE</sub> ≈ 18 A (estimation)	27	29	31	A
		Peak Efficiency = 16 A; (MFR_SPECIFIC_15<1:0> = 10b); Offset = 6 A; (MFR_SPECIFIC_15<4:3> = 10b); V <sub>RIPPLE</sub> ≈ 18 A (estimation)	29	31	33	A
		Peak Efficiency = 16 A; (MFR_SPECIFIC_15<1:0> = 10b); Offset = 8 A; (MFR_SPECIFIC_15<4:3> = 11b); V <sub>RIPPLE</sub> ≈ 18 A (estimation)	31	33	35	A
		Peak Efficiency = 18 A; (MFR_SPECIFIC_15<1:0> = 11b); Offset = 2 A; (MFR_SPECIFIC_15<4:3> = 00b); V <sub>RIPPLE</sub> ≈ 18 A (estimation)	27	29	31	A
		Peak Efficiency = 18 A; (MFR_SPECIFIC_15<1:0> = 11b); Offset = 4 A; (MFR_SPECIFIC_15<4:3> = 01b); V <sub>RIPPLE</sub> ≈ 18 A (estimation)	29	31	33	A
		Peak Efficiency = 18 A; (MFR_SPECIFIC_15<1:0> = 11b); Offset = 6 A; (MFR_SPECIFIC_15<4:3> = 10b); V <sub>RIPPLE</sub> ≈ 18 A (estimation)	31	33	35	A
Peak Efficiency = 18 A; (MFR_SPECIFIC_15<1:0> = 11b); Offset = 8 A; (MFR_SPECIFIC_15<4:3> = 11b); V <sub>RIPPLE</sub> ≈ 18 A (estimation)	33	35	37	A		

### Dynamic Phase Add and Drop (continued)

over recommended operating conditions (unless otherwise noted)

PARAMETER		TEST CONDITIONS	MIN	TYP	MAX	UNIT
V <sub>DPSTHS1</sub>	Dynamic phase shedding threshold, 2 to 1 phase (average current)	Peak Efficiency = 12 A; (MFR_SPECIFIC_15<1:0> = 00b); Offset = -6 A; (MFR_SPECIFIC_15<14:13> = 00b)	4	6	8	A
		Peak Efficiency = 12 A; (MFR_SPECIFIC_15<1:0> = 00b); Offset = -4 A; (MFR_SPECIFIC_15<14:13> = 01b)	6	8	10	A
		Peak Efficiency = 12 A; (MFR_SPECIFIC_15<1:0> = 00b); Offset = -2 A; (MFR_SPECIFIC_15<14:13> = 10b)	8	10	12	A
		Peak Efficiency = 12 A; (MFR_SPECIFIC_15<1:0> = 00b); Offset = 0 A; (MFR_SPECIFIC_15<14:13> = 11b)	10	12	14	A
		Peak Efficiency = 14 A; (MFR_SPECIFIC_15<1:0> = 01b); Offset = -6 A; (MFR_SPECIFIC_15<14:13> = 00b)	6	8	10	A
		Peak Efficiency = 14 A; (MFR_SPECIFIC_15<1:0> = 01b); Offset = -4 A; (MFR_SPECIFIC_15<14:13> = 01b)	8	10	12	A
		Peak Efficiency = 14 A; (MFR_SPECIFIC_15<1:0> = 01b); Offset = -2 A; (MFR_SPECIFIC_15<14:13> = 10b)	10	12	14	A
		Peak Efficiency = 14 A; (MFR_SPECIFIC_15<1:0> = 01b); Offset = 0 A; (MFR_SPECIFIC_15<14:13> = 11b)	12	14	16	A
		Peak Efficiency = 16 A; (MFR_SPECIFIC_15<1:0> = 10b); Offset = -6 A; (MFR_SPECIFIC_15<14:13> = 00b)	8	10	12	A
		Peak Efficiency = 16 A; (MFR_SPECIFIC_15<1:0> = 10b); Offset = -4 A; (MFR_SPECIFIC_15<14:13> = 01b)	10	12	14	A
		Peak Efficiency = 16 A; (MFR_SPECIFIC_15<1:0> = 10b); Offset = -2 A; (MFR_SPECIFIC_15<14:13> = 10b)	12	14	16	A
		Peak Efficiency = 16 A; (MFR_SPECIFIC_15<1:0> = 10b); Offset = 0 A; (MFR_SPECIFIC_15<14:13> = 11b)	14	16	18	A
		Peak Efficiency = 18 A; (MFR_SPECIFIC_15<1:0> = 11b); Offset = -6 A; (MFR_SPECIFIC_15<14:13> = 00b)	10	12	14	A
		Peak Efficiency = 18 A; (MFR_SPECIFIC_15<1:0> = 11b); Offset = -4 A; (MFR_SPECIFIC_15<14:13> = 01b)	12	14	16	A
		Peak Efficiency = 18 A; (MFR_SPECIFIC_15<1:0> = 11b); Offset = -2 A; (MFR_SPECIFIC_15<14:13> = 10b)	14	16	18	A
Peak Efficiency = 18 A; (MFR_SPECIFIC_15<1:0> = 11b); Offset = 0 A; (MFR_SPECIFIC_15<14:13> = 11b)	16	18	20	A		

### Dynamic Phase Add and Drop (continued)

over recommended operating conditions (unless otherwise noted)

PARAMETER	TEST CONDITIONS	MIN	TYP	MAX	UNIT	
V <sub>DPSTHA2</sub>	Dynamic phase adding threshold, 2 to 3 phases (Peak Current)	Peak Efficiency = 12 A; (MFR_SPECIFIC_15<1:0> = 00b); Offset = 4 A; (MFR_SPECIFIC_15<6:5> = 00b); V <sub>RIPPLE</sub> = 14 A (estimation)	32.5	35	37.5	A
	Peak Efficiency = 12 A; (MFR_SPECIFIC_15<1:0> = 00b); Offset = 6 A; (MFR_SPECIFIC_15<6:5> = 01b); V <sub>RIPPLE</sub> = 14 A (estimation)	34.5	37	39.5	A	
	Peak Efficiency = 12 A; (MFR_SPECIFIC_15<1:0> = 00b); Offset = 8 A; (MFR_SPECIFIC_15<6:5> = 10b); V <sub>RIPPLE</sub> = 14 A (estimation)	36.5	39	41.5	A	
	Peak Efficiency = 12 A; (MFR_SPECIFIC_15<1:0> = 00b); Offset = 10 A; (MFR_SPECIFIC_15<6:5> = 11b); V <sub>RIPPLE</sub> = 14 A (estimation)	38.5	41	43.5	A	
	Peak Efficiency = 14 A; (MFR_SPECIFIC_15<1:0> = 01b); Offset = 4 A; (MFR_SPECIFIC_15<6:5> = 00b); V <sub>RIPPLE</sub> = 14 A (estimation)	36.5	39	41.5	A	
	Peak Efficiency = 14 A; (MFR_SPECIFIC_15<1:0> = 01b); Offset = 6 A; (MFR_SPECIFIC_15<6:5> = 01b); V <sub>RIPPLE</sub> = 14 A (estimation)	38.5	41	43.5	A	
	Peak Efficiency = 14 A; (MFR_SPECIFIC_15<1:0> = 01b); Offset = 8 A; (MFR_SPECIFIC_15<6:5> = 10b); V <sub>RIPPLE</sub> = 14 A (estimation)	40.5	43	45.5	A	
	Peak Efficiency = 14 A; (MFR_SPECIFIC_15<1:0> = 01b); Offset = 10 A; (MFR_SPECIFIC_15<6:5> = 11b); V <sub>RIPPLE</sub> = 14 A (estimation)	42.5	45	47.5	A	
	Peak Efficiency = 16 A; (MFR_SPECIFIC_15<1:0> = 10b); Offset = 4 A; (MFR_SPECIFIC_15<6:5> = 00b); V <sub>RIPPLE</sub> = 14 A (estimation)	40.5	43	45.5	A	
	Peak Efficiency = 16 A; (MFR_SPECIFIC_15<1:0> = 10b); Offset = 6 A; (MFR_SPECIFIC_15<6:5> = 01b); V <sub>RIPPLE</sub> = 14 A (estimation)	42.5	45	47.5	A	
	Peak Efficiency = 16 A; (MFR_SPECIFIC_15<1:0> = 10b); Offset = 8 A; (MFR_SPECIFIC_15<6:5> = 10b); V <sub>RIPPLE</sub> = 14 A (estimation)	44.5	47	49.5	A	
	Peak Efficiency = 16 A; (MFR_SPECIFIC_15<1:0> = 10b); Offset = 10 A; (MFR_SPECIFIC_15<6:5> = 11b); V <sub>RIPPLE</sub> = 14 A (estimation)	46.5	49	51.5	A	
	Peak Efficiency = 18 A; (MFR_SPECIFIC_15<1:0> = 11b); Offset = 4 A; (MFR_SPECIFIC_15<6:5> = 00b); V <sub>RIPPLE</sub> = 14 A (estimation)	44.5	47	49.5	A	
	Peak Efficiency = 18 A; (MFR_SPECIFIC_15<1:0> = 11b); Offset = 6 A; (MFR_SPECIFIC_15<6:5> = 01b); V <sub>RIPPLE</sub> = 14 A (estimation)	46.5	49	51.5	A	
	Peak Efficiency = 18 A; (MFR_SPECIFIC_15<1:0> = 11b); Offset = 8 A; (MFR_SPECIFIC_15<6:5> = 10b); V <sub>RIPPLE</sub> = 14 A (estimation)	48.5	51	53.5	A	
Peak Efficiency = 18 A; (MFR_SPECIFIC_15<1:0> = 11b); Offset = 10 A; (MFR_SPECIFIC_15<6:5> = 11b); V <sub>RIPPLE</sub> = 14 A (estimation)	50.5	53	55.5	A		

### Dynamic Phase Add and Drop (continued)

over recommended operating conditions (unless otherwise noted)

PARAMETER		TEST CONDITIONS	MIN	TYP	MAX	UNIT
V <sub>DPSTHS2</sub>	Dynamic phase shedding threshold, 3 to 2 phases (average current)	Peak Efficiency = 12 A; (MFR_SPECIFIC_15<1:0> = 00b); Offset = -4 A; (MFR_SPECIFIC_14<9:8> = 00b)	17.5	20	22.5	A
		Peak Efficiency = 12 A; (MFR_SPECIFIC_15<1:0> = 00b); Offset = -2 A; (MFR_SPECIFIC_14<9:8> = 01b)	19.5	22	24.5	A
		Peak Efficiency = 12 A; (MFR_SPECIFIC_15<1:0> = 00b); Offset = 0 A; (MFR_SPECIFIC_14<9:8> = 10b)	21.5	24	26.5	A
		Peak Efficiency = 12 A; (MFR_SPECIFIC_15<1:0> = 00b); Offset = 2 A; (MFR_SPECIFIC_14<9:8> = 11b)	23.5	26	28.5	A
		Peak Efficiency = 14 A; (MFR_SPECIFIC_15<1:0> = 01b); Offset = -4 A; (MFR_SPECIFIC_14<9:8> = 00b)	21.5	24	26.5	A
		Peak Efficiency = 14 A; (MFR_SPECIFIC_15<1:0> = 01b); Offset = -2 A; (MFR_SPECIFIC_14<9:8> = 01b)	23.5	26	28.5	A
		Peak Efficiency = 14 A; (MFR_SPECIFIC_15<1:0> = 01b); Offset = 0 A; (MFR_SPECIFIC_14<9:8> = 10b)	25.5	28	30.5	A
		Peak Efficiency = 14 A; (MFR_SPECIFIC_15<1:0> = 01b); Offset = 2 A; (MFR_SPECIFIC_14<9:8> = 11b)	27.5	30	32.5	A
		Peak Efficiency = 16 A; (MFR_SPECIFIC_15<1:0> = 10b); Offset = -4 A; (MFR_SPECIFIC_14<9:8> = 00b)	25.5	28	30.5	A
		Peak Efficiency = 16 A; (MFR_SPECIFIC_15<1:0> = 10b); Offset = -2 A; (MFR_SPECIFIC_14<9:8> = 01b)	27.5	30	32.5	A
		Peak Efficiency = 16 A; (MFR_SPECIFIC_15<1:0> = 10b); Offset = 0 A; (MFR_SPECIFIC_14<9:8> = 10b)	29.5	32	34.5	A
		Peak Efficiency = 16 A; (MFR_SPECIFIC_15<1:0> = 10b); Offset = 2 A; (MFR_SPECIFIC_14<9:8> = 11b)	31.5	34	36.5	A
		Peak Efficiency = 18 A; (MFR_SPECIFIC_15<1:0> = 11b); Offset = -4 A; (MFR_SPECIFIC_14<9:8> = 00b)	29.5	32	34.5	A
		Peak Efficiency = 18 A; (MFR_SPECIFIC_15<1:0> = 11b); Offset = -2 A; (MFR_SPECIFIC_14<9:8> = 01b)	31.5	34	36.5	A
		Peak Efficiency = 18 A; (MFR_SPECIFIC_15<1:0> = 11b); Offset = 0 A; (MFR_SPECIFIC_14<9:8> = 10b)	33.5	36	38.5	A
Peak Efficiency = 18 A; (MFR_SPECIFIC_15<1:0> = 11b); Offset = 2 A; (MFR_SPECIFIC_14<9:8> = 11b)	35.5	38	40.5	A		

**Dynamic Phase Add and Drop (continued)**

over recommended operating conditions (unless otherwise noted)

PARAMETER		TEST CONDITIONS	MIN	TYP	MAX	UNIT
V <sub>DPSTHA3</sub>	Dynamic phase adding threshold, 3 to 4 Phases (Peak Current)	Peak Efficiency = 12 A; (MFR_SPECIFIC_15<1:0> = 00b); Offset = 6 A; (MFR_SPECIFIC_15<8:7> = 00b); V <sub>RIPPLE</sub> = 10 A (estimation)	44	47	50	A
		Peak Efficiency = 12 A; (MFR_SPECIFIC_15<1:0> = 00b); Offset = 8 A; (MFR_SPECIFIC_15<8:7> = 01b); V <sub>RIPPLE</sub> = 10 A (estimation)	46	49	52	A
		Peak Efficiency = 12 A; (MFR_SPECIFIC_15<1:0> = 00b); Offset = 10 A; (MFR_SPECIFIC_15<8:7> = 10b); V <sub>RIPPLE</sub> = 10 A (estimation)	48	51	54	A
		Peak Efficiency = 12 A; (MFR_SPECIFIC_15<1:0> = 00b); Offset = 12 A; (MFR_SPECIFIC_15<8:7> = 11b); V <sub>RIPPLE</sub> = 10 A (estimation)	50	53	56	A
		Peak Efficiency = 14 A; (MFR_SPECIFIC_15<1:0> = 01b); Offset = 6 A; (MFR_SPECIFIC_15<8:7> = 00b); V <sub>RIPPLE</sub> = 10 A (estimation)	50	53	56	A
		Peak Efficiency = 14 A; (MFR_SPECIFIC_15<1:0> = 01b); Offset = 8 A; (MFR_SPECIFIC_15<8:7> = 01b); V <sub>RIPPLE</sub> = 10 A (estimation)	52	55	58	A
		Peak Efficiency = 14 A; (MFR_SPECIFIC_15<1:0> = 01b); Offset = 10 A; (MFR_SPECIFIC_15<8:7> = 10b); V <sub>RIPPLE</sub> = 10 A (estimation)	54	57	60	A
		Peak Efficiency = 14 A; (MFR_SPECIFIC_15<1:0> = 01b); Offset = 12 A; (MFR_SPECIFIC_15<8:7> = 11b); V <sub>RIPPLE</sub> = 10 A (estimation)	56	59	62	A
		Peak Efficiency = 16 A; (MFR_SPECIFIC_15<1:0> = 10b); Offset = 6 A; (MFR_SPECIFIC_15<8:7> = 00b); V <sub>RIPPLE</sub> = 10 A (estimation)	56	59	62	A
		Peak Efficiency = 16 A; (MFR_SPECIFIC_15<1:0> = 10b); Offset = 8 A; (MFR_SPECIFIC_15<8:7> = 01b); V <sub>RIPPLE</sub> = 10 A (estimation)	58	61	64	A
		Peak Efficiency = 16 A; (MFR_SPECIFIC_15<1:0> = 10b); Offset = 10 A; (MFR_SPECIFIC_15<8:7> = 10b); V <sub>RIPPLE</sub> = 10 A (estimation)	60	63	66	A
		Peak Efficiency = 16 A; (MFR_SPECIFIC_15<1:0> = 10b); Offset = 12 A; (MFR_SPECIFIC_15<8:7> = 11b); V <sub>RIPPLE</sub> = 10 A (estimation)	62	65	68	A
		Peak Efficiency = 18 A; (MFR_SPECIFIC_15<1:0> = 11b); Offset = 6 A; (MFR_SPECIFIC_15<8:7> = 00b); V <sub>RIPPLE</sub> = 10 A (estimation)	62	65	68	A
		Peak Efficiency = 18 A; (MFR_SPECIFIC_15<1:0> = 11b); Offset = 8 A; (MFR_SPECIFIC_15<8:7> = 01b); V <sub>RIPPLE</sub> = 10 A (estimation)	64	67	70	A
		Peak Efficiency = 18 A; (MFR_SPECIFIC_15<1:0> = 11b); Offset = 10 A; (MFR_SPECIFIC_15<8:7> = 10b); V <sub>RIPPLE</sub> = 10 A (estimation)	66	69	72	A
Peak Efficiency = 18 A; (MFR_SPECIFIC_15<1:0> = 11b); Offset = 12 A; (MFR_SPECIFIC_15<8:7> = 11b); V <sub>RIPPLE</sub> = 10 A (estimation)	68	71	74	A		

### Dynamic Phase Add and Drop (continued)

over recommended operating conditions (unless otherwise noted)

PARAMETER		TEST CONDITIONS	MIN	TYP	MAX	UNIT
V <sub>DPSTHS3</sub>	Dynamic phase shedding threshold, 4 to 3 phases (average current)	Peak Efficiency = 12 A; (MFR_SPECIFIC_15<1:0> = 00b); Offset = -2 A; (MFR_SPECIFIC_14<11:10> = 00b)	31	34	37	A
		Peak Efficiency = 12 A; (MFR_SPECIFIC_15<1:0> = 00b); Offset = 0 A; (MFR_SPECIFIC_14<11:10> = 01b)	33	36	39	A
		Peak Efficiency = 12 A; (MFR_SPECIFIC_15<1:0> = 00b); Offset = 2 A; (MFR_SPECIFIC_14<11:10> = 10b)	35	38	41	A
		Peak Efficiency = 12 A; (MFR_SPECIFIC_15<1:0> = 00b); Offset = 4 A; (MFR_SPECIFIC_14<11:10> = 11b)	37	40	43	A
		Peak Efficiency = 14 A; (MFR_SPECIFIC_15<1:0> = 01b); Offset = -2 A; (MFR_SPECIFIC_14<11:10> = 00b)	37	40	43	A
		Peak Efficiency = 14 A; (MFR_SPECIFIC_15<1:0> = 01b); Offset = 0 A; (MFR_SPECIFIC_14<11:10> = 01b)	39	42	45	A
		Peak Efficiency = 14 A; (MFR_SPECIFIC_15<1:0> = 01b); Offset = 2 A; (MFR_SPECIFIC_14<11:10> = 10b)	41	44	47	A
		Peak Efficiency = 14 A; (MFR_SPECIFIC_15<1:0> = 01b); Offset = 4 A; (MFR_SPECIFIC_14<11:10> = 11b)	43	46	49	A
		Peak Efficiency = 16 A; (MFR_SPECIFIC_15<1:0> = 10b); Offset = -2 A; (MFR_SPECIFIC_14<11:10> = 00b)	43	46	49	A
		Peak Efficiency = 16 A; (MFR_SPECIFIC_15<1:0> = 10b); Offset = 0 A; (MFR_SPECIFIC_14<11:10> = 01b)	45	48	51	A
		Peak Efficiency = 16 A; (MFR_SPECIFIC_15<1:0> = 10b); Offset = 2 A; (MFR_SPECIFIC_14<11:10> = 10b)	47	50	53	A
		Peak Efficiency = 16 A; (MFR_SPECIFIC_15<1:0> = 10b); Offset = 4 A; (MFR_SPECIFIC_14<11:10> = 11b)	49	52	55	A
		Peak Efficiency = 18 A; (MFR_SPECIFIC_15<1:0> = 11b); Offset = -2 A; (MFR_SPECIFIC_14<11:10> = 00b)	49	52	55	A
		Peak Efficiency = 18 A; (MFR_SPECIFIC_15<1:0> = 11b); Offset = 0 A; (MFR_SPECIFIC_14<11:10> = 01b)	51	54	57	A
		Peak Efficiency = 18 A; (MFR_SPECIFIC_15<1:0> = 11b); Offset = 2 A; (MFR_SPECIFIC_14<11:10> = 10b)	53	56	59	A
		Peak Efficiency = 18 A; (MFR_SPECIFIC_15<1:0> = 11b); Offset = 4 A; (MFR_SPECIFIC_14<11:10> = 11b)	55	58	61	A

**Dynamic Phase Add and Drop (continued)**

over recommended operating conditions (unless otherwise noted)

PARAMETER		TEST CONDITIONS	MIN	TYP	MAX	UNIT
V <sub>DPSTHA4</sub>	Dynamic phase adding threshold, 4 to 5 Phases (Peak Current)	Peak Efficiency = 12 A; (MFR_SPECIFIC_15<1:0> = 00b); Offset = 6 A; (MFR_SPECIFIC_15<10:9> = 00b); V <sub>RIPPLE</sub> = 8 A (estimation)	54.5	58	61.5	A
		Peak Efficiency = 12 A; (MFR_SPECIFIC_15<1:0> = 00b); Offset = 8 A; (MFR_SPECIFIC_15<10:9> = 01b); V <sub>RIPPLE</sub> = 8 A (estimation)	56.5	60	63.5	A
		Peak Efficiency = 12 A; (MFR_SPECIFIC_15<1:0> = 00b); Offset = 10 A; (MFR_SPECIFIC_15<10:9> = 10b); V <sub>RIPPLE</sub> = 8 A (estimation)	58.5	62	65.5	A
		Peak Efficiency = 12 A; (MFR_SPECIFIC_15<1:0> = 00b); Offset = 12 A; (MFR_SPECIFIC_15<10:9> = 11b); V <sub>RIPPLE</sub> = 8 A (estimation)	60.5	64	67.5	A
		Peak Efficiency = 14 A; (MFR_SPECIFIC_15<1:0> = 01b); Offset = 6 A; (MFR_SPECIFIC_15<10:9> = 00b); V <sub>RIPPLE</sub> = 8 A (estimation)	62.5	66	69.5	A
		Peak Efficiency = 14 A; (MFR_SPECIFIC_15<1:0> = 01b); Offset = 8 A; (MFR_SPECIFIC_15<10:9> = 01b); V <sub>RIPPLE</sub> = 8 A (estimation)	64.5	68	71.5	A
		Peak Efficiency = 14 A; (MFR_SPECIFIC_15<1:0> = 01b); Offset = 10 A; (MFR_SPECIFIC_15<10:9> = 10b); V <sub>RIPPLE</sub> = 8 A (estimation)	66.5	70	73.5	A
		Peak Efficiency = 14 A; (MFR_SPECIFIC_15<1:0> = 01b); Offset = 12 A; (MFR_SPECIFIC_15<10:9> = 11b); V <sub>RIPPLE</sub> = 8 A (estimation)	68.5	72	75.5	A
		Peak Efficiency = 16 A; (MFR_SPECIFIC_15<1:0> = 10b); Offset = 6 A; (MFR_SPECIFIC_15<10:9> = 00b); V <sub>RIPPLE</sub> = 8 A (estimation)	70.5	74	77.5	A
		Peak Efficiency = 16 A; (MFR_SPECIFIC_15<1:0> = 10b); Offset = 8 A; (MFR_SPECIFIC_15<10:9> = 01b); V <sub>RIPPLE</sub> = 8 A (estimation)	72.5	76	79.5	A
		Peak Efficiency = 16 A; (MFR_SPECIFIC_15<1:0> = 10b); Offset = 10 A; (MFR_SPECIFIC_15<10:9> = 10b); V <sub>RIPPLE</sub> = 8 A (estimation)	74.5	78	81.5	A
		Peak Efficiency = 16 A; (MFR_SPECIFIC_15<1:0> = 10b); Offset = 12 A; (MFR_SPECIFIC_15<10:9> = 11b); V <sub>RIPPLE</sub> = 8 A (estimation)	76.5	80	83.5	A
		Peak Efficiency = 18 A; (MFR_SPECIFIC_15<1:0> = 11b); Offset = 6 A; (MFR_SPECIFIC_15<10:9> = 00b); V <sub>RIPPLE</sub> = 8 A (estimation)	78.5	82	85.5	A
		Peak Efficiency = 18 A; (MFR_SPECIFIC_15<1:0> = 11b); Offset = 8 A; (MFR_SPECIFIC_15<10:9> = 01b); V <sub>RIPPLE</sub> = 8 A (estimation)	80.5	84	87.5	A
		Peak Efficiency = 18 A; (MFR_SPECIFIC_15<1:0> = 11b); Offset = 10 A; (MFR_SPECIFIC_15<10:9> = 10b); V <sub>RIPPLE</sub> = 8 A (estimation)	82.5	86	89.5	A
Peak Efficiency = 18 A; (MFR_SPECIFIC_15<1:0> = 11b); Offset = 12 A; (MFR_SPECIFIC_15<10:9> = 11b); V <sub>RIPPLE</sub> = 8 A (estimation)	84.5	88	91.5	A		

### Dynamic Phase Add and Drop (continued)

over recommended operating conditions (unless otherwise noted)

PARAMETER		TEST CONDITIONS	MIN	TYP	MAX	UNIT
V <sub>DPSTHS4</sub>	Dynamic phase shedding threshold, 5 to 4 phases (average current)	Peak Efficiency = 12 A; (MFR_SPECIFIC_15<1:0> = 00b); Offset = -2 A; (MFR_SPECIFIC_14<13:12> = 00b)	42.5	46	49.5	A
		Peak Efficiency = 12 A; (MFR_SPECIFIC_15<1:0> = 00b); Offset = 0 A; (MFR_SPECIFIC_14<13:12> = 01b)	44.5	48	51.5	A
		Peak Efficiency = 12 A; (MFR_SPECIFIC_15<1:0> = 00b); Offset = 2 A; (MFR_SPECIFIC_14<13:12> = 10b)	46.5	50	53.5	A
		Peak Efficiency = 12 A; (MFR_SPECIFIC_15<1:0> = 00b); Offset = 4 A; (MFR_SPECIFIC_14<13:12> = 11b)	48.5	52	55.5	A
		Peak Efficiency = 14 A; (MFR_SPECIFIC_15<1:0> = 01b); Offset = -2 A; (MFR_SPECIFIC_14<13:12> = 00b)	50.5	54	57.5	A
		Peak Efficiency = 14 A; (MFR_SPECIFIC_15<1:0> = 01b); Offset = 0 A; (MFR_SPECIFIC_14<13:12> = 01b)	52.5	56	59.5	A
		Peak Efficiency = 14 A; (MFR_SPECIFIC_15<1:0> = 01b); Offset = 2 A; (MFR_SPECIFIC_14<13:12> = 10b)	54.5	58	61.5	A
		Peak Efficiency = 14 A; (MFR_SPECIFIC_15<1:0> = 01b); Offset = 4 A; (MFR_SPECIFIC_14<13:12> = 11b)	56.5	60	63.5	A
		Peak Efficiency = 16 A; (MFR_SPECIFIC_15<1:0> = 10b); Offset = -2 A; (MFR_SPECIFIC_14<13:12> = 00b)	58.5	62	65.5	A
		Peak Efficiency = 16 A; (MFR_SPECIFIC_15<1:0> = 10b); Offset = 0 A; (MFR_SPECIFIC_14<13:12> = 01b)	60.5	64	67.5	A
		Peak Efficiency = 16 A; (MFR_SPECIFIC_15<1:0> = 10b); Offset = 2 A; (MFR_SPECIFIC_14<13:12> = 10b)	62.5	66	69.5	A
		Peak Efficiency = 16 A; (MFR_SPECIFIC_15<1:0> = 10b); Offset = 4 A; (MFR_SPECIFIC_14<13:12> = 11b)	64.5	68	71.5	A
		Peak Efficiency = 18 A; (MFR_SPECIFIC_15<1:0> = 11b); Offset = -2 A; (MFR_SPECIFIC_14<13:12> = 00b)	66.5	70	73.5	A
		Peak Efficiency = 18 A; (MFR_SPECIFIC_15<1:0> = 11b); Offset = 0 A; (MFR_SPECIFIC_14<13:12> = 01b)	68.5	72	75.5	A
		Peak Efficiency = 18 A; (MFR_SPECIFIC_15<1:0> = 11b); Offset = 2 A; (MFR_SPECIFIC_14<13:12> = 10b)	70.5	74	77.5	A
Peak Efficiency = 18 A; (MFR_SPECIFIC_15<1:0> = 11b); Offset = 4 A; (MFR_SPECIFIC_14<13:12> = 11b)	72.5	76	79.5	A		

### Dynamic Phase Add and Drop (continued)

over recommended operating conditions (unless otherwise noted)

PARAMETER		TEST CONDITIONS	MIN	TYP	MAX	UNIT
V <sub>DPSTHA5</sub>	Dynamic phase adding threshold, 5 to 6 Phases (Peak Current)	Peak Efficiency = 12 A; (MFR_SPECIFIC_15<1:0> = 00b); Offset = 6 A; (MFR_SPECIFIC_15<12:11> = 00b); V <sub>RIPPLE</sub> = 6 A (estimation)	65	69	73	A
		Peak Efficiency = 12 A; (MFR_SPECIFIC_15<1:0> = 00b); Offset = 8 A; (MFR_SPECIFIC_15<12:11> = 01b); V <sub>RIPPLE</sub> = 6 A (estimation)	67	71	75	A
		Peak Efficiency = 12 A; (MFR_SPECIFIC_15<1:0> = 00b); Offset = 10 A; (MFR_SPECIFIC_15<12:11> = 10b); V <sub>RIPPLE</sub> = 6 A (estimation)	69	73	77	A
		Peak Efficiency = 12 A; (MFR_SPECIFIC_15<1:0> = 00b); Offset = 12 A; (MFR_SPECIFIC_15<12:11> = 11b); V <sub>RIPPLE</sub> = 6 A (estimation)	71	75	79	A
		Peak Efficiency = 14 A; (MFR_SPECIFIC_15<1:0> = 01b); Offset = 6 A; (MFR_SPECIFIC_15<12:11> = 00b); V <sub>RIPPLE</sub> = 6 A (estimation)	75	79	83	A
		Peak Efficiency = 14 A; (MFR_SPECIFIC_15<1:0> = 01b); Offset = 8 A; (MFR_SPECIFIC_15<12:11> = 01b); V <sub>RIPPLE</sub> = 6 A (estimation)	77	81	85	A
		Peak Efficiency = 14 A; (MFR_SPECIFIC_15<1:0> = 01b); Offset = 10 A; (MFR_SPECIFIC_15<12:11> = 10b); V <sub>RIPPLE</sub> = 6 A (estimation)	79	83	87	A
		Peak Efficiency = 14 A; (MFR_SPECIFIC_15<1:0> = 01b); Offset = 12 A; (MFR_SPECIFIC_15<12:11> = 11b); V <sub>RIPPLE</sub> = 6 A (estimation)	81	85	89	A
		Peak Efficiency = 16 A; (MFR_SPECIFIC_15<1:0> = 10b); Offset = 6 A; (MFR_SPECIFIC_15<12:11> = 00b); V <sub>RIPPLE</sub> = 6 A (estimation)	85	89	93	A
		Peak Efficiency = 16 A; (MFR_SPECIFIC_15<1:0> = 10b); Offset = 8 A; (MFR_SPECIFIC_15<12:11> = 01b); V <sub>RIPPLE</sub> = 6 A (estimation)	87	91	95	A
		Peak Efficiency = 16 A; (MFR_SPECIFIC_15<1:0> = 10b); Offset = 10 A; (MFR_SPECIFIC_15<12:11> = 10b); V <sub>RIPPLE</sub> = 6 A (estimation)	89	93	97	A
		Peak Efficiency = 16 A; (MFR_SPECIFIC_15<1:0> = 10b); Offset = 12 A; (MFR_SPECIFIC_15<12:11> = 11b); V <sub>RIPPLE</sub> = 6 A (estimation)	91	95	99	A
		Peak Efficiency = 18 A; (MFR_SPECIFIC_15<1:0> = 11b); Offset = 6 A; (MFR_SPECIFIC_15<12:11> = 00b); V <sub>RIPPLE</sub> = 6 A (estimation)	95	99	103	A
		Peak Efficiency = 18 A; (MFR_SPECIFIC_15<1:0> = 11b); Offset = 8 A; (MFR_SPECIFIC_15<12:11> = 01b); V <sub>RIPPLE</sub> = 6 A (estimation)	97	101	105	A
		Peak Efficiency = 18 A; (MFR_SPECIFIC_15<1:0> = 11b); Offset = 10 A; (MFR_SPECIFIC_15<12:11> = 10b); V <sub>RIPPLE</sub> = 6 A (estimation)	99	103	107	A
Peak Efficiency = 18 A; (MFR_SPECIFIC_15<1:0> = 11b); Offset = 12 A; (MFR_SPECIFIC_15<12:11> = 11b); V <sub>RIPPLE</sub> = 6 A (estimation)	101	105	109	A		

### Dynamic Phase Add and Drop (continued)

over recommended operating conditions (unless otherwise noted)

PARAMETER		TEST CONDITIONS	MIN	TYP	MAX	UNIT
V <sub>DPSTHS5</sub>	Dynamic phase shedding threshold, 6 to 5 phases (average current)	Peak Efficiency = 12 A; (MFR_SPECIFIC_15<1:0> = 00b); Offset = -2 A; (MFR_SPECIFIC_14<15:14> = 00b)	54	58	62	A
		Peak Efficiency = 12 A; (MFR_SPECIFIC_15<1:0> = 00b); Offset = 0 A; (MFR_SPECIFIC_14<15:14> = 01b)	56	60	64	A
		Peak Efficiency = 12 A; (MFR_SPECIFIC_15<1:0> = 00b); Offset = 2 A; (MFR_SPECIFIC_14<15:14> = 10b)	58	62	66	A
		Peak Efficiency = 12 A; (MFR_SPECIFIC_15<1:0> = 00b); Offset = 4 A; (MFR_SPECIFIC_14<15:14> = 11b)	60	64	68	A
		Peak Efficiency = 14 A; (MFR_SPECIFIC_15<1:0> = 01b); Offset = -2 A; (MFR_SPECIFIC_14<15:14> = 00b)	64	68	72	A
		Peak Efficiency = 14 A; (MFR_SPECIFIC_15<1:0> = 01b); Offset = 0 A; (MFR_SPECIFIC_14<15:14> = 01b)	66	70	74	A
		Peak Efficiency = 14 A; (MFR_SPECIFIC_15<1:0> = 01b); Offset = 2 A; (MFR_SPECIFIC_14<15:14> = 10b)	68	72	76	A
		Peak Efficiency = 14 A; (MFR_SPECIFIC_15<1:0> = 01b); Offset = 4 A; (MFR_SPECIFIC_14<15:14> = 11b)	70	74	78	A
		Peak Efficiency = 16 A; (MFR_SPECIFIC_15<1:0> = 10b); Offset = -2 A; (MFR_SPECIFIC_14<15:14> = 00b)	74	78	82	A
		Peak Efficiency = 16 A; (MFR_SPECIFIC_15<1:0> = 10b); Offset = 0 A; (MFR_SPECIFIC_14<15:14> = 01b)	76	80	84	A
		Peak Efficiency = 16 A; (MFR_SPECIFIC_15<1:0> = 10b); Offset = 2 A; (MFR_SPECIFIC_14<15:14> = 10b)	78	82	86	A
		Peak Efficiency = 16 A; (MFR_SPECIFIC_15<1:0> = 10b); Offset = 4 A; (MFR_SPECIFIC_14<15:14> = 11b)	80	84	88	A
		Peak Efficiency = 18 A; (MFR_SPECIFIC_15<1:0> = 11b); Offset = -2 A; (MFR_SPECIFIC_14<15:14> = 00b)	84	88	92	A
		Peak Efficiency = 18 A; (MFR_SPECIFIC_15<1:0> = 11b); Offset = 0 A; (MFR_SPECIFIC_14<15:14> = 01b)	86	90	94	A
		Peak Efficiency = 18 A; (MFR_SPECIFIC_15<1:0> = 11b); Offset = 2 A; (MFR_SPECIFIC_14<15:14> = 10b)	88	92	96	A
		Peak Efficiency = 18 A; (MFR_SPECIFIC_15<1:0> = 11b); Offset = 4 A; (MFR_SPECIFIC_14<15:14> = 11b)	90	94	98	A

## 6.25 Typical Characteristics



图 2. VOUTA Load Line



图 3. Efficiency

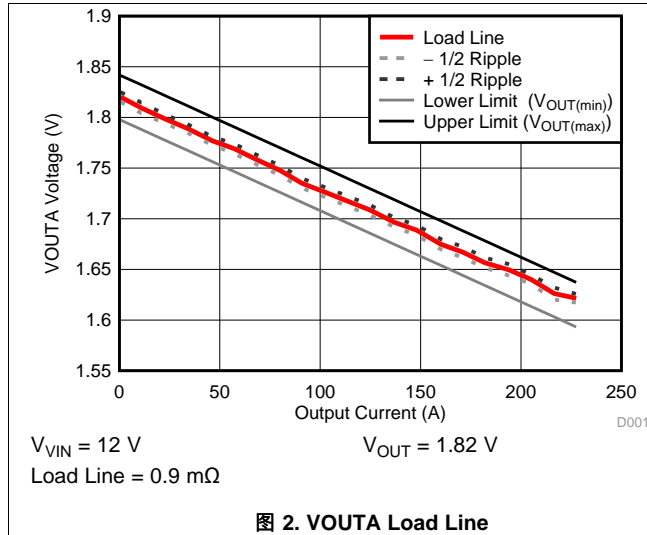

图 4. VOUTA Reported Input Power by PMBus

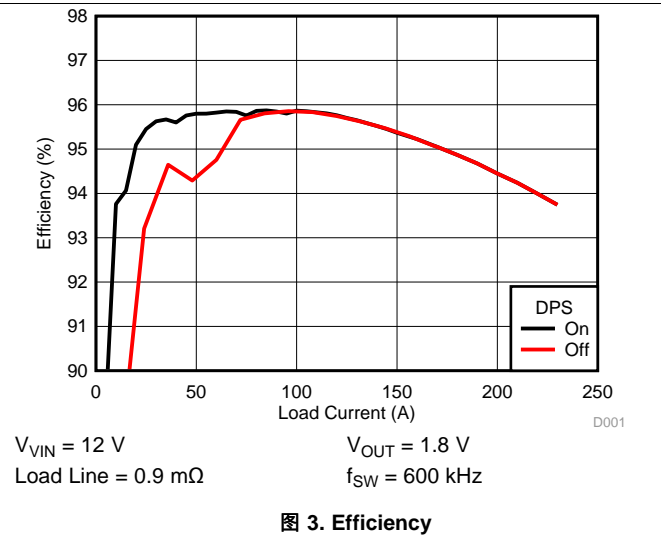

图 5. VOUTA Reported Output Current by PMBus

## 7 Detailed Description

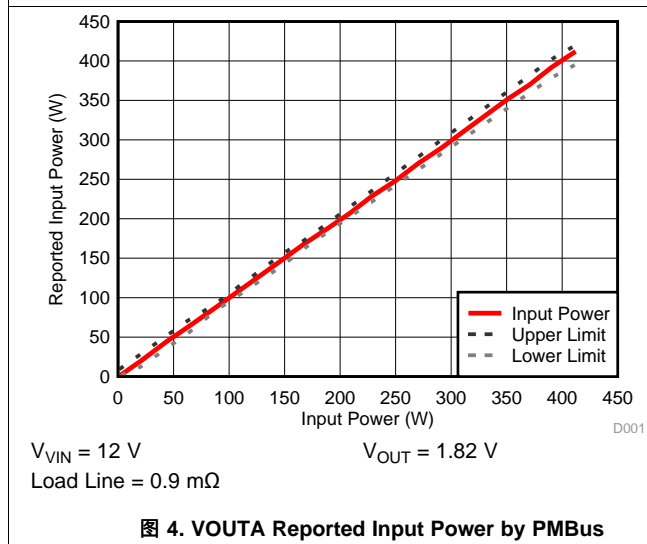
### 7.1 Overview

The TPS53681 is a multiphase step-down controller with dual channels, built-in non-volatile memory (NVM), and PMBus™ interface, and is fully compatible with TI NexFET™ power stages. Advanced control features such as D-CAP+™ architecture with undershoot reduction (USR) provide transient response,

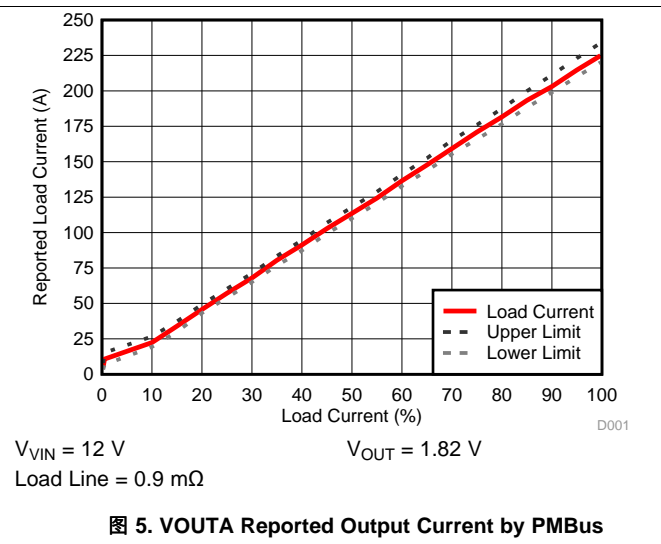
### 7.2 Functional Block Diagram

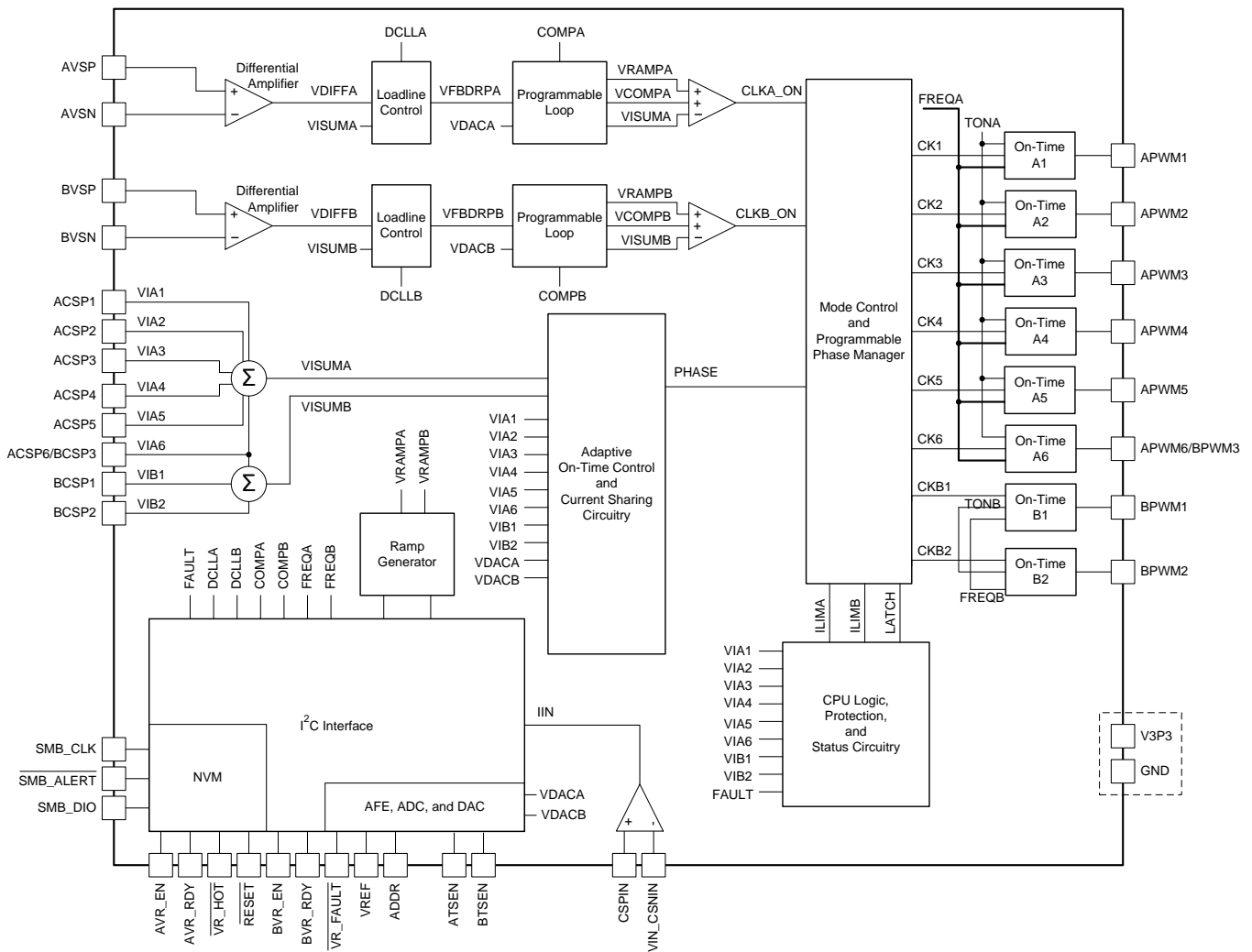

Copyright © 2017, Texas Instruments Incorporated

### 7.3 Feature Description

#### 7.3.1 Phase Interleaving and PWM Operation

As shown in the [Overview](#) section, in 8-phase continuous conduction mode, the device operates as described in [Figure 6](#).

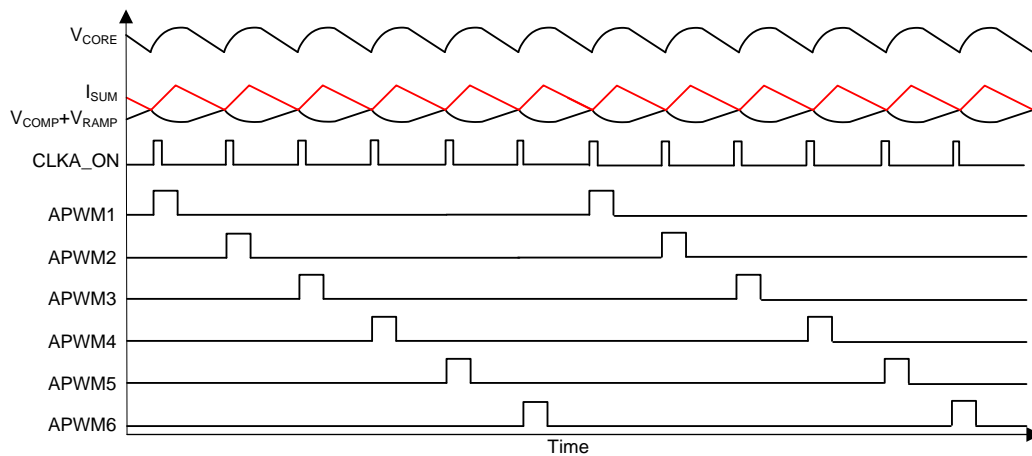
**Feature Description (接下页)**

**图 6. D-CAP+ Mode Basic Waveforms**

Starting with the condition that the high-side FETs are off and the low-side FETs are on, the summed current feedback ( $V_{ISUM}$ ) is higher than the summed error amplifier output ( $V_{COMP}$ ) and the internal ramp signal ( $V_{RAMP}$ ).  $I_{SUM}$  falls until it hits  $V_{COMP}+V_{RAMP}$ , which contains a component of the output ripple voltage. The PWM comparator senses where the two waveforms cross and triggers the on-time generator. This generates the internal CLKA\_ON signal. Each CLKA\_ON signal corresponds to one switching ON pulse for one phase.

In case of single-phase operation, every CLKA\_ON signal generates a switching pulse on the same phase. Also,  $V_{ISUM}$  corresponds to just a single-phase inductor current.

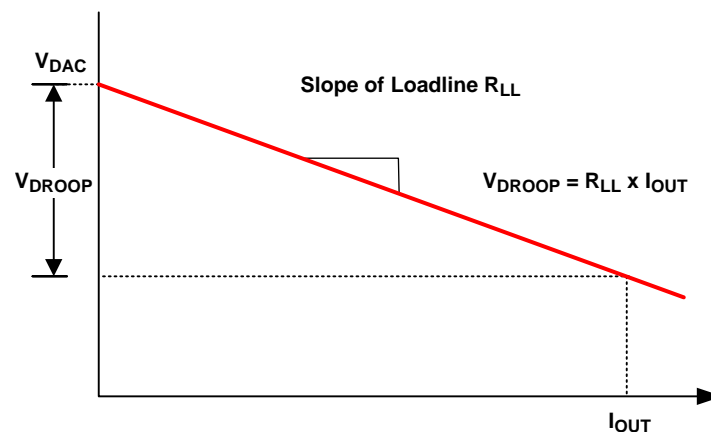
In case of multi-phase operation, the CLKA\_ON signal gets distributed to each of the phases in a cycle. This approach of using the summed inductor current and cyclically distributing the ON pulses to each phase automatically gives the required interleaving of  $360 / n$ , where  $n$  is the number of phases.

**7.3.1.1 Setting the Load-Line (DROOP)**

**图 7. Load Line**

The loadline can be set with VOUT\_DROOP register via PMBus. The programmable range for channel A is between 0 mΩ and 3.125 mΩ with 64 options, and the range for channel B is between 0 mΩ and 0.875 mΩ with 16 options to fulfill the requirements for different applications.

## Feature Description (接下页)

### 7.3.1.2 Load Transitions

When there is a sudden load increase, the output voltage immediately drops. The TPS53681 device reacts to this drop in a rising voltage on the COMP pin. This rise forces the PWM pulses to come in sooner and more frequently which causes the inductor current to rapidly increase. As the inductor current reaches the new load current, the device reaches a steady-state operating condition and the PWM switching resumes the steady-state frequency.

When there is a sudden load release, the output voltage flies high. The TPS53681 device reacts to this rise in a falling voltage on the COMP pin. This drop forces the PWM pulses to be delayed until the inductor current reaches the new load current. At that point, the switching resumes and steady-state switching continues.

Please note in 图 8 and 图 9, the ripples on  $V_{OUT}$ ,  $V_{RAMP}$ , and  $V_{COMP}$  voltages are not shown for simplicity.



图 8. Load Insertion



图 9. Load Release

The TPS53681 achieves fast load transient performance using the inherent variable switching frequency characteristics. 图 8 illustrates the load insertion behavior that the PWM pulses can be generated with faster frequency than the steady-state frequency to provide more energy to improve the undershoot performance. 图 9 illustrates the load release behavior that PWM pulses can be gated to avoid charging extra energy to the load until the output voltage reaches the peak overshoot.

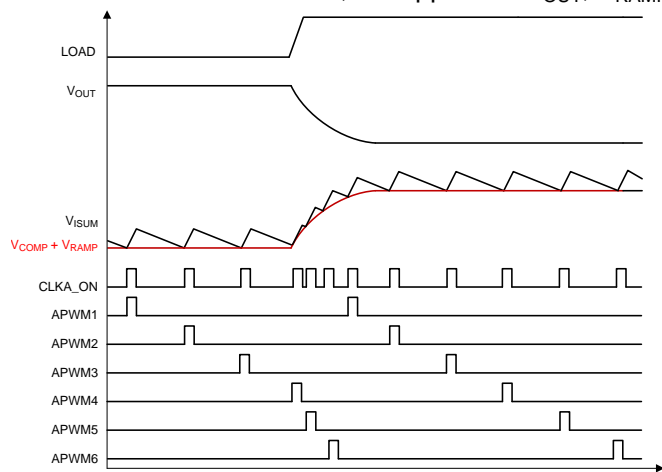
#### 7.3.1.2.1 VID Table

The DAC voltage  $V_{DAC}$  can be changed via PMBus according to 表 2 . Set the `VOUT_SCALE_LOOP` command to 1.125 to achieve output voltages higher than 2.500. The controller will acknowledge all VID codes and ignore those which are unsupported per the table below.

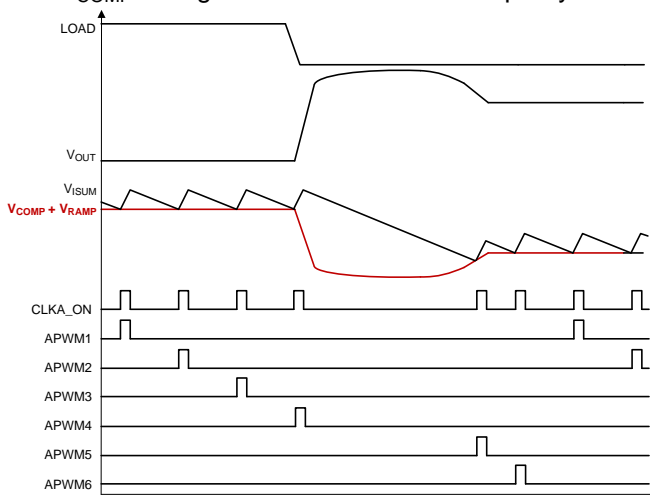
**表 2. VID Table**

VID Hex VALUE	DAC STEP (5 mV)	DAC STEP (10 mV)
00	0	0
01	0.25	0.50
02	0.255	0.51
03	0.26	0.52
04	0.265	0.53
05	0.27	0.54
06	0.275	0.55
07	0.28	0.56
08	0.285	0.57
09	0.29	0.58
0A	0.295	0.59
0B	0.30	0.60
0C	0.305	0.61
0D	0.31	0.62
0E	0.315	0.63
0F	0.32	0.64
10	0.325	0.65
11	0.33	0.66
12	0.335	0.67
13	0.34	0.68
14	0.345	0.69
15	0.35	0.70
16	0.355	0.71
17	0.36	0.72
18	0.365	0.73
19	0.37	0.74
1A	0.375	0.75
1B	0.38	0.76
1C	0.385	0.77
1D	0.39	0.78
1E	0.395	0.79
1F	0.40	0.80
20	0.405	0.81
21	0.41	0.82
22	0.415	0.83
23	0.42	0.84
24	0.425	0.85
25	0.43	0.86
26	0.435	0.87
27	0.44	0.88
28	0.445	0.89
29	0.45	0.90
2A	0.455	0.91
2B	0.46	0.92
2C	0.465	0.93
2D	0.47	0.94
2E	0.475	0.95

**表 2. VID Table (接下页)**

VID Hex VALUE	DAC STEP (5 mV)	DAC STEP (10 mV)
2F	0.48	0.96
30	0.485	0.97
31	0.49	0.98
32	0.495	0.99
33	0.50	1.00
34	0.505	1.01
35	0.51	1.02
36	0.515	1.03
37	0.52	1.04
38	0.525	1.05
39	0.53	1.06
3A	0.535	1.07
3B	0.54	1.08
3C	0.545	1.09
3D	0.55	1.10
3E	0.555	1.11
3F	0.56	1.12
40	0.565	1.13
41	0.57	1.14
42	0.575	1.15
43	0.58	1.16
44	0.585	1.17
45	0.59	1.18
46	0.595	1.19
47	0.60	1.20
48	0.605	1.21
49	0.61	1.22
4A	0.615	1.23
4B	0.62	1.24
4C	0.625	1.25
4D	0.63	1.26
4E	0.635	1.27
4F	0.64	1.28
50	0.645	1.29
51	0.65	1.30
52	0.655	1.31
53	0.66	1.32
54	0.665	1.33
55	0.67	1.34
56	0.675	1.35
57	0.68	1.36
58	0.685	1.37
59	0.69	1.38
5A	0.695	1.39
5B	0.70	1.40
5C	0.705	1.41
5D	0.71	1.42

**表 2. VID Table (接下页)**

VID Hex VALUE	DAC STEP (5 mV)	DAC STEP (10 mV)
5E	0.715	1.43
5F	0.72	1.44
60	0.725	1.45
61	0.73	1.46
62	0.735	1.47
63	0.74	1.48
64	0.745	1.49
65	0.75	1.50
66	0.755	1.51
67	0.76	1.52
68	0.765	1.53
69	0.77	1.54
6A	0.775	1.55
6B	0.78	1.56
6C	0.785	1.57
6D	0.79	1.58
6E	0.795	1.59
6F	0.80	1.60
70	0.805	1.61
71	0.81	1.62
72	0.815	1.63
73	0.82	1.64
74	0.825	1.65
75	0.83	1.66
76	0.835	1.67
77	0.84	1.68
78	0.845	1.69
79	0.85	1.70
7A	0.855	1.71
7B	0.86	1.72
7C	0.865	1.73
7D	0.87	1.74
7E	0.875	1.75
7F	0.88	1.76
80	0.885	1.77
81	0.89	1.78
82	0.895	1.79
83	0.90	1.80
84	0.905	1.81
85	0.91	1.82
86	0.915	1.83
87	0.92	1.84
88	0.925	1.85
89	0.93	1.86
8A	0.935	1.87
8B	0.94	1.88
8C	0.945	1.89

**表 2. VID Table (接下页)**

VID Hex VALUE	DAC STEP (5 mV)	DAC STEP (10 mV)
8D	0.95	1.90
8E	0.955	1.91
8F	0.96	1.92
90	0.965	1.93
91	0.97	1.94
92	0.975	1.95
93	0.98	1.96
94	0.985	1.97
95	0.99	1.98
96	0.995	1.99
97	1.00	2.00
98	1.005	2.01
99	1.01	2.02
9A	1.015	2.03
9B	1.02	2.04
9C	1.025	2.05
9D	1.03	2.06
9E	1.035	2.07
9F	1.04	2.08
A0	1.045	2.09
A1	1.05	2.10
A2	1.055	2.11
A3	1.06	2.12
A4	1.065	2.13
A5	1.07	2.14
A6	1.075	2.15
A7	1.08	2.16
A8	1.085	2.17
A9	1.09	2.18
AA	1.095	2.19
AB	1.10	2.20
AC	1.105	2.21
AD	1.11	2.22
AE	1.115	2.23
AF	1.12	2.24
B0	1.125	2.25
B1	1.13	2.26
B2	1.135	2.27
B3	1.14	2.28
B4	1.145	2.29
B5	1.15	2.30
B6	1.155	2.31
B7	1.16	2.32
B8	1.165	2.33
B9	1.17	2.34
BA	1.175	2.35
BB	1.18	2.36

**表 2. VID Table (接下页)**

VID Hex VALUE	DAC STEP (5 mV)	DAC STEP (10 mV)
BC	1.185	2.37
BD	1.19	2.38
BE	1.195	2.39
BF	1.20	2.40
C0	1.205	2.41
C1	1.21	2.42
C2	1.215	2.43
C3	1.22	2.44
C4	1.225	2.45
C5	1.23	2.46
C6	1.235	2.47
C7	1.24	2.48
C8	1.245	2.49
C9	1.25	2.50
CA	1.255	n/a
CB	1.26	n/a
CC	1.265	n/a
CD	1.27	n/a
CE	1.275	n/a
CF	1.28	n/a
D0	1.285	n/a
D1	1.29	n/a
D2	1.295	n/a
D3	1.30	n/a
D4	1.305	n/a
D5	1.31	n/a
D6	1.315	n/a
D7	1.32	n/a
D8	1.325	n/a
D9	1.33	n/a
DA	1.335	n/a
DB	1.34	n/a
DC	1.345	n/a
DD	1.35	n/a

**表 2. VID Table (接下页)**

VID Hex VALUE	DAC STEP (5 mV)	DAC STEP (10 mV)
DE	1.355	n/a
DF	1.36	n/a
E0	1.365	n/a
E1	1.37	n/a
E2	1.375	n/a
E3	1.38	n/a
E4	1.385	n/a
E5	1.39	n/a
E6	1.395	n/a
E7	1.40	n/a
E8	1.405	n/a
E9	1.41	n/a
EA	1.415	n/a
EB	1.42	n/a
EC	1.425	n/a
ED	1.43	n/a
EE	1.435	n/a
EF	1.44	n/a
F0	1.445	n/a
F1	1.45	n/a
F2	1.455	n/a
F3	1.46	n/a
F4	1.465	n/a
F5	1.47	n/a
F6	1.475	n/a
F7	1.48	n/a
F8	1.485	n/a
F9	1.49	n/a
FA	1.495	n/a
FB	1.50	n/a
FC	1.505	n/a
FD	1.51	n/a
FE	1.515	n/a
FF	1.52	n/a

### 7.3.1.3 Temperature and Fault Sensing

TI smart power stage senses the die temperature and sends out the temperature information as a voltage through the TAO pin. In a multi-phase application, the TAO pin of the TI smart power stages are connected together and then tied to the ATSEN and BTSEN pins of the TPS53681 device. In this case, the device reports the temperature of the hottest power stage. The reported temperature can be calculated as shown in 公式 1.

$$\text{TEMP} = \frac{(V_{\text{TSEN}} - 0.6)}{0.008}$$

where

- TEMP is the sensed temperature in °C
- $V_{\text{TSEN}}$  is the voltage at ATSEN and BTSEN pins (1)

TSEN signal is also used as an indicator for power stage fault. When an internal fault occurs in the TI smart power stage, the power stage pulls the xTAO pins high. If the TSEN voltage is higher than 2.5 V, the TPS53681 device senses the fault and turns off both the high-side and the low-side MOSFETS.

The TSEN signal is also used to indicate hand-shaking between the controller and the power stages. If the power stages are not powered, the TAO pin is pulled down to prevent switching, even if the controller is enabled.

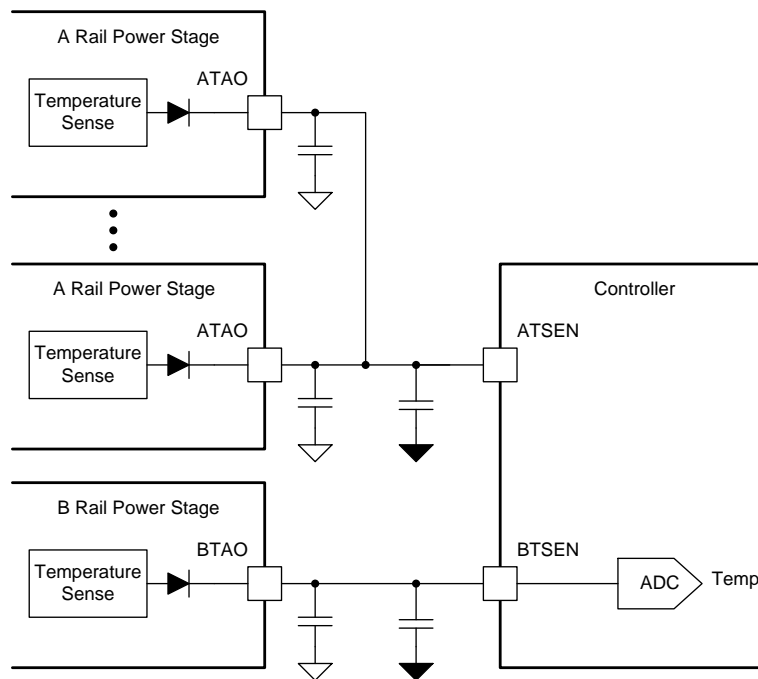

Copyright © 2017, Texas Instruments Incorporated

图 10. Temperature Sense

### 7.3.1.4 AutoBalance™ Current Sharing

The basic mechanism for current sharing is to sense the average phase current, then adjust the pulse width of each phase to equalize the current in each phase as shown in 图 11. The PWM comparator (not shown) starts a pulse when the feedback voltage meets the reference. The  $V_{\text{IN}}$  voltage charges  $C_{\text{t(on)}}$  through  $R_{\text{t(on)}}$ . The pulse terminates when the voltage at  $C_{\text{t(on)}}$  matches the on-time reference, which normally equals the DAC voltage ( $V_{\text{DAC}}$ ).

The circuit operates in the following fashion. First assume that the 1- $\mu\text{s}$  averaged value from each phase current are equal. In this case, the PWM modulator terminates at  $V_{\text{DAC}}$ , and the normal pulse width is delivered to the system. If instead,  $I_1 > I_{\text{AVG}}$ , then an offset is subtracted from  $V_{\text{DAC}}$ , and the pulse width for Phase 1 is shortened to reduce the phase current in Phase 1 for balancing. If  $I_1 < I_{\text{AVG}}$ , then a longer pulse is generated to increase the phase current in Phase 1 to achieve current balancing.



图 11. AutoBalance Current Sharing Circuit Detail

### 7.3.1.5 Phase Configuration for Channel B

By default, the second rail of the TPS53681 is configured for two-phase operation. Two NVM bits, CHB\_2PH and CHB\_3PH control the number of phases available to channel B. The CHB\_2PH bit is found in MFR\_SPECIFIC\_13 (bit 12), and the CHB\_3PH bit is found in USER\_DATA\_11. See 表 3 below, which describes these bit settings, versus phase configuration for channel B. Refer to the accompanying *Technical Reference Manual* for a register map of MFR\_SPECIFIC\_13 and USER\_DATA\_11. Refer to [Current Sense Inputs for Active Phases](#) for information about pin configuration of CSP signals for various channel B phase configuration settings.

表 3. Channel B Phase Configuration

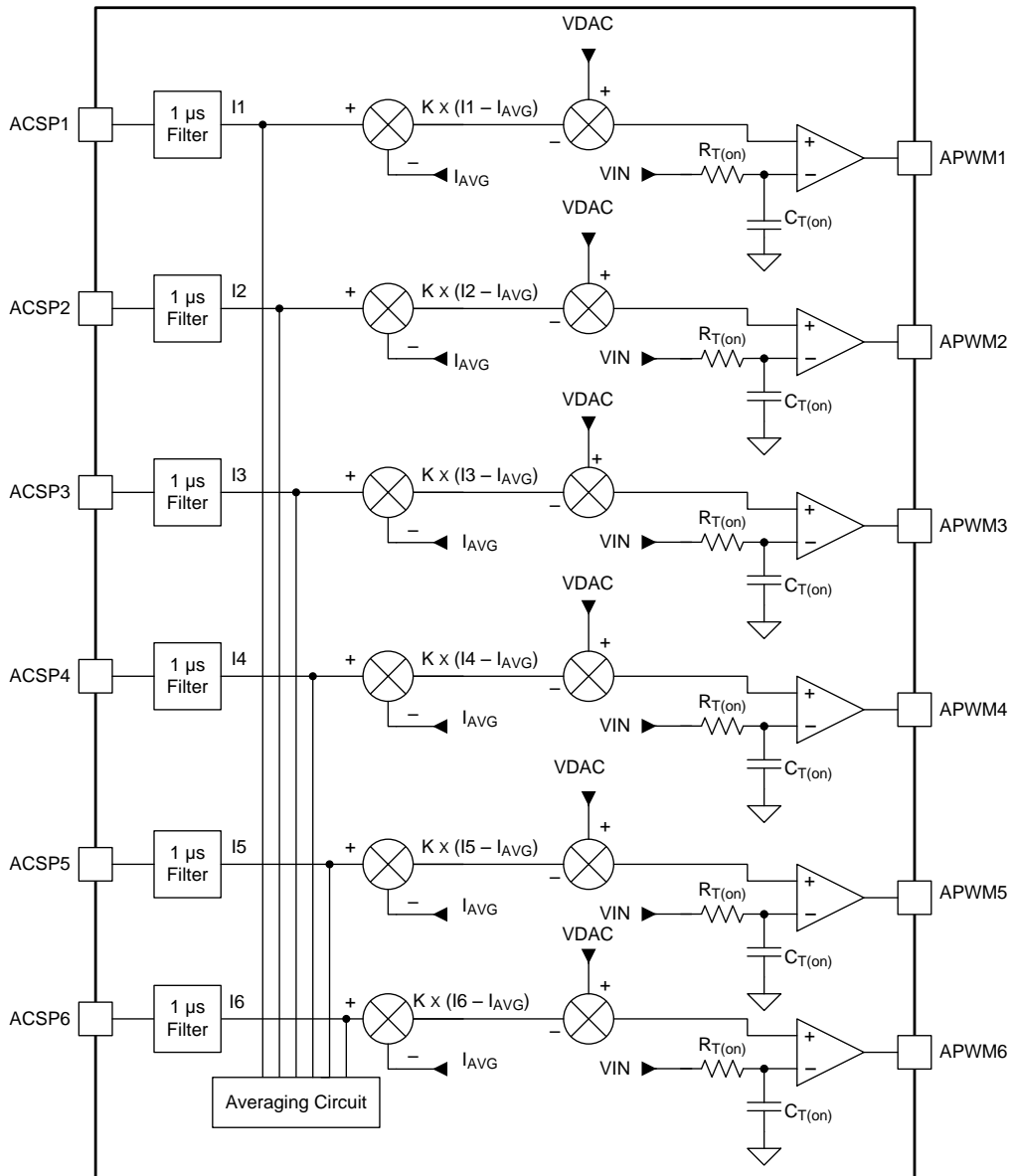
Channel B Phases	CHB_2PH MFR_SPECIFIC_13[PAGE0][12] USER_DATA_11[PAGE0][9]	CHB_3PH USER_DATA_11[PAGE0][9]
1	1b	0b
2	0b	0b
3	0b	1b

### 7.3.1.6 RESET Function

During adaptive voltage scaling (AVS) operation, the voltage may become falsely adjusted to be out of ASIC operating range. The RESET function returns the voltage to the VBOOT voltage. When the voltage is out of ASIC operating range, the ASIC issues a  $\overline{\text{RESET}}$  signal to the TPS53681 device, as shown in 图 12. The device senses this signal and after a delay of greater than 1  $\mu\text{s}$ , it sets an internal RESET\_FAULT signal and sets VOUT\_COMMAND to VBOOT. The device pulls the output voltage to the VBOOT level with the slew rate set by VOUT\_TRANSITION\_RATE command, as shown in 图 13.

When the  $\overline{\text{RESET}}$  pin signal goes high, the internal RESET\_FAULT signal goes low.



图 12.  $\overline{\text{RESET}}$  Pin Connection



图 13. Reset Function

## 7.4 Device Functional Modes

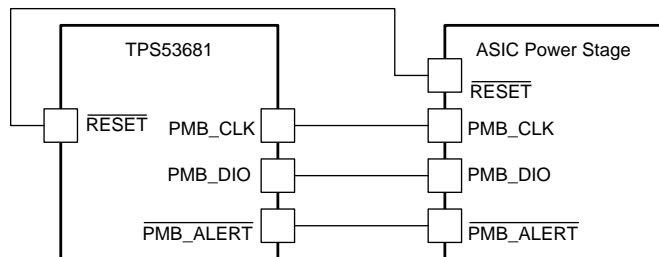
## 7.5 Programming

### 7.5.1 PMBus Connections

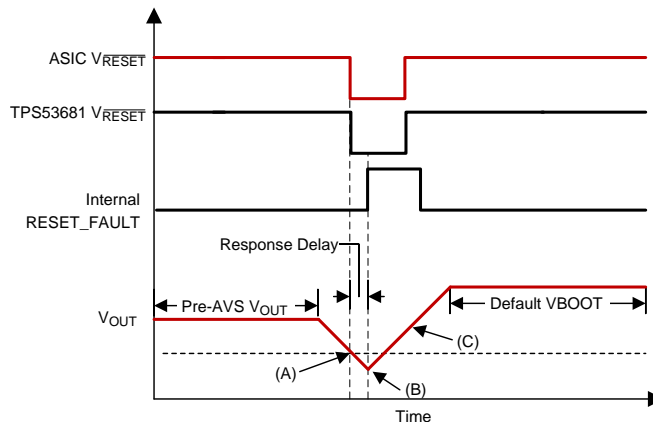
The TPS53681 device can support either 100kHz class, 400 kHz class or 1 MHz class operation, with 1.8-V or 3.3-V logic levels. Connection for the PMBus interface should follow the DC specifications given in *Section 4.3 of the System Management Bus (SMBus) Specification V3.0*. The complete SMBus specification is available from the SMBus website, [smbus.org](http://smbus.org).

### 7.5.2 PMBus Address Selection

The PMBus slave addresses for TPS53681 are selected with a resistor divider from VREF to ADDR.

## Programming (continued)

The PMBus slave address is set by the voltage on the ADDR pin. Refer to [Table 4](#). With the desired PMBus address, and  $R_{\text{ADDRL}}$  selected, calculate the  $R_{\text{ADDRH}}$  using [Equation 2](#).

Note that TPS53681 uses 7 bit addressing, per the SMBus specification. Users communicating to the device using generic I<sup>2</sup>C drivers should be aware that these 7 bits occupy the most significant bits of the first byte in each transaction, with the least significant bit being the data direction bit (0 for write operations, 1 for read operations). That is, for read transactions, the address byte is  $A_6A_5A_4A_3A_2A_1A_01$  and for write operations the address byte is  $A_6A_5A_4A_3A_2A_1A_00$ . Refer to the SMBus specification for more information.

The general procedure for selecting these resistors is as follows:

1. Determine the desired PMBus slave addresses, per system requirements
2. Select an  $R_{\text{ADDRL}}$  value of 10 k $\Omega$  or 20 k $\Omega$
3. Using the desired PMBus address, refer to [Table 4](#) for the desired address pin voltage
4. Use [Equation 2](#) to calculate  $R_{\text{ADDRH}}$

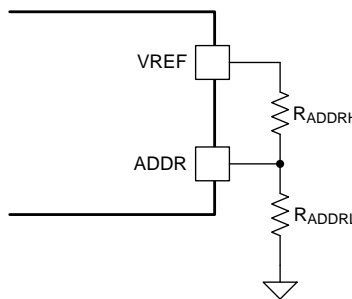

**Figure 14. PMBus Address Selection**

Contact your local Texas Instruments representative for a copy of the PMBus address setting design tool spreadsheet.

$$R_{\text{ADDRH}} = R_{\text{ADDRL}} \left( \frac{V_{\text{REF}}}{V_{\text{ADDR}}} - 1 \right)$$

(2)

**Table 4. PMBus Slave Address Selection**

$V_{\text{ADDR}}$ (V)	PMBus Address (7 bit binary) $A_6A_5A_4A_3A_2A_1A_0$	PMBus Address (7-bit decimal)	I <sup>2</sup> C Address Byte (Write Operation)	I <sup>2</sup> C Address Byte (Read Operation)
$\leq 0.039$ V	1011000b	88d	B0h	B1h
$0.073$ V $\pm$ 15 mV	1011001b	89d	B2h	B3h
$0.122$ V $\pm$ 15 mV	1011010b	90d	B4h	B5h
$0.171$ V $\pm$ 15 mV	1011011b	91d	B6h	B7h
$0.219$ V $\pm$ 15 mV	1011100b	92d	B8h	B9h
$0.268$ V $\pm$ 15 mV	1011101b	93d	BAh	BBh
$0.317$ V $\pm$ 15 mV	1011110b	94d	BC h	BD h
$0.366$ V $\pm$ 15 mV	1011111b	95d	BEh	BFh
$0.415$ V $\pm$ 15 mV	1100000b	96d	C0h	C1h
$0.464$ V $\pm$ 15 mV	1100001b	97d	C2h	C3h
$0.513$ V $\pm$ 15 mV	1100010b	98d	C4h	C5h
$0.562$ V $\pm$ 15 mV	1100011b	99d	C6h	C7h
$0.610$ V $\pm$ 15 mV	1100100b	100d	C8h	C9h
$0.660$ V $\pm$ 15 mV	1100101b	101d	CAh	CBh
$0.708$ V $\pm$ 15 mV	1100110b	102d	CCh	CDh

**Table 4. PMBus Slave Address Selection (continued)**

V <sub>ADDR</sub> (V)	PMBus Address (7 bit binary) A <sub>6</sub> A <sub>5</sub> A <sub>4</sub> A <sub>3</sub> A <sub>2</sub> A <sub>1</sub> A <sub>0</sub>	PMBus Address (7-bit decimal)	I <sup>2</sup> C Address Byte (Write Operation)	I <sup>2</sup> C Address Byte (Read Operation)
0.757 V ± 15 mV	1100111b	103d	CEh	CFh
0.806 V ± 15 mV	1101000b	104d	D0h	D1h
0.854 V ± 15 mV	1101001b	105d	D2h	D3h
0.903 V ± 15 mV	1101010b	106d	D4h	D5h
0.952 V ± 15 mV	1101011b	107d	D6h	D7h
1.000 V ± 15 mV	1101100b	108d	D8h	D9h
1.050 V ± 15 mV	1101101b	109d	DAh	DBh
1.098 V ± 15 mV	1101110b	110d	DCh	DDh
1.147 V ± 15 mV	1101111b	111d	DEh	DFh
1.196 V ± 15 mV	1110000b	112d	E0h	E1h
1.245 V ± 15 mV	1110001b	113d	E2h	E3h
1.294 V ± 15 mV	1110010b	114d	E4h	E5h
1.343 V ± 15 mV	1110011b	115d	E6h	E7h
1.392 V ± 15 mV	1110100b	116d	E8h	E9h
1.440 V ± 15 mV	1110101b	117d	EAh	EBh
1.489 V ± 15 mV	1110110b	118d	ECh	EDh
1.540 V ± 15 mV	1110111b	119d	EEh	EFh

### 7.5.3 Supported Commands

The table below summarizes the PMBus commands supported by the TPS53681. Only selected commands, which are most commonly used during device configuration and usage are reproduced in this document. For a full set of register maps for this device, refer to the accompanying *Technical Reference Manual*.

CMD	Command Name	Description	R/W, NVM	Default Behavior	Default Value	
					Ch. A (PAGE 0)	Ch. B PAGE 1
00h	PAGE	Selects which channel subsequent PMBus commands address	RW	All commands address Channel A	N/A	
01h	OPERATION	Enable or disable each channel, enter or exit margin.	RW	Conversion disabled. Margin None.	00h	00h
02h	ON_OFF_CONFIG	Configure the combination of OPERATION, and enable pin required to enable power conversion for each channel.	RW, NVM	OPERATION command only.	1Bh	1Bh
03h	CLEAR_FAULT	Clears all fault status registers to 00h and releases PMB_ALERT	W	Write-only	N/A	
04h	PHASE	Selects which phase of the active channel subsequent PMBus commands address	RW	Commands address all phases.	FFh	FFh
10h	WRITE_PROTECT	Used to control writing to the volatile operating memory (PMBus and restore from NVM).	RW	Writes to all commands are allowed	00h	
11h	STORE_DEFAULT_ALL	Stores all current storable register settings into NVM as new defaults.	W	Write-only	N/A	
12h	RESTORE_DEFAULT_ALL	Restores all storable register settings from NVM.	W	Write-only	N/A	
19h	CAPABILITY	Provides a way for a host system to determine key PMBus capabilities of the device.	R	1 MHz, PEC, PMB_ALERT Supported	D0h	
1Bh	SMBALERT_MASK (STATUS_VOUT)	Selects which faults/status bits may to assert PMB_ALERT	RW, NVM	All bits may assert PMB_ALERT	00h	00h
1Bh	SMBALERT_MASK (STATUS_IOUT)	Selects which faults/status bits may to assert PMB_ALERT	RW, NVM	All bits may assert PMB_ALERT	00h	00h
1Bh	SMBALERT_MASK (STATUS_INPUT)	Selects which faults/status bits may to assert PMB_ALERT	RW, NVM	LOW_VIN does not assert PMB_ALERT	08h	08h
1Bh	SMBALERT_MASK (STATUS_TEMPERATURE)	Selects which faults/status bits may to assert PMB_ALERT	RW, NVM	All bits may assert PMB_ALERT	00h	00h
1Bh	SMBALERT_MASK (STATUS_CML)	Selects which faults/status bits may to assert PMB_ALERT	RW, NVM	All bits may assert PMB_ALERT	00h	00h
1Bh	SMBALERT_MASK (STATUS_MFR_SPECIFIC)	Selects which faults/status bits may to assert PMB_ALERT	RW, NVM	All bits may assert PMB_ALERT	00h	00h
20h	VOUT_MODE	Read-only output mode indicator	R <sup>(1)</sup>	VID mode. 5 mV Step (Ch A), 5 mV Step (Ch B)	21h	21h
21h	VOUT_COMMAND	Output voltage target.	RW, NVM	0.500 V (Ch A) 0.500 V (Ch B)	0033h	0033h
24h	VOUT_MAX	Sets the maximum output voltage	RW, NVM	1.520 V (Ch A) 1.520 V (Ch B)	00FFh	00FFh
25h	VOUT_MARGIN_HIGH	Load the unit with the voltage to which the output is to be changed when OPERATION command is set to "Margin High".	RW	0.000 V (CH A) 0.000 V (Ch B)	0000h	0000h
26h	VOUT_MARGIN_LOW	Load the unit with the voltage to which the output is to be changed when OPERATION command is set to "Margin Low".	RW	0.000 V (CH A) 0.000 V (Ch B)	0000h	0000h
27h	VOUT_TRANSITION_RATE	Used to set slew rate settings for output voltage updates	RW, NVM	1.5625 mV/μs (Ch A) 1.5625 mV/μs (Ch B)	E019h	E019h

(1) NVM-backed bits in the MFR\_SPECIFIC or USER\_DATA commands affect the reset value of these commands. Refer to the individual register maps for more detail.

CMD	Command Name	Description	R/W, NVM	Default Behavior	Default Value	
					Ch. A (PAGE 0)	Ch. B PAGE 1
28h	VOUT_DROOP	The VOUT_DROOP sets the rate, in mV/A (mΩ) at which the output voltage decreases (or increases) with increasing (or decreasing) output current for use with Adaptive Voltage Positioning	RW, NVM	0.000 mΩ (Ch A) 0.000 mΩ (Ch B)	D000h	D000h
29h	VOUT_SCALE_LOOP	Used for scaling the VID code	RW, NVM	1.000 (Ch A) 1.000 (Ch B)	E808h	E808h
2Ah	VOUT_SCALE_MONITOR	Used for scaling output voltage telemetry	RW, NVM	1.000 (Ch A) 1.000 (Ch B)	E808h	E808h
2Bh	VOUT_MIN	Sets the minimum output voltage	RW, NVM	0.000 V (Ch A) 0.000 V (Ch B)	0000h	0000h
33h	FREQUENCY_SWITCH	Sets the switching frequency	RW, NVM	500 kHz (Ch A) 500 kHz (Ch B)	01F4h	01F4h
35h	VIN_ON	Sets value of input voltage at which the device should start power conversion.	RW, NVM	6.25 V	F019h	
38h	IOUT_CAL_GAIN	Sets the ratio of voltage at the current sense pins to the sensed current.	RW, NVM	5.000 mΩ (Ch A) 5.000 mΩ (Ch B)	D140h	D140h
39h	IOUT_CAL_OFFSET	Used to null offsets in the output current sensing circuit	RW, NVM	0.000 A (Ch A) 0.000 A (Ch B) (All Phases)	E800h	E800h
40h	VOUT_OV_FAULT_LIMIT	Sets the value of the sensed output voltage which triggers an output overvoltage fault	R	1.520 V (Ch A) 1.520 V (Ch B)	00FFh	00FFh
41h	VOUT_OV_FAULT_RESPONSE	Sets the converter response to an output overvoltage event	R	Shutdown, do not restart	80h	80h
44h	VOUT_UV_FAULT_LIMIT	Sets the value of the sensed output voltage which triggers an output undervoltage fault	R	0.000 V (Ch A) 0.000 V (Ch B)	0000h	0000h
45h	VOUT_UV_FAULT_RESPONSE	Sets the converter response to an output undervoltage event	RW, NVM	Shutdown, do not restart	80h	80h
46h	IOUT_OC_FAULT_LIMIT	Sets the output Over Current fault limit	RW, NVM <sup>(1)</sup>	39 A (Ch A) 39 A (Ch B)	0027h	0027h
47h	IOUT_OC_FAULT_RESPONSE	Define the over-current fault response.	RW, NVM	Shutdown, and Hiccup	FAh	FAh
4Ah	IOUT_OC_WARN_LIMIT	Sets the value of the output current that causes the over current detector to indicate an over current warning.	RW, NVM <sup>(1)</sup>	26 A (Ch A) 26 A (Ch B)	001Ah	001Ah
4Fh	OT_FAULT_LIMIT	Sets the temperature, in degrees Celsius, of the unit at which it should indicate an Over temperature Fault.	RW, NVM <sup>(1)</sup>	135 °C (Ch A) 135 °C (Ch B)	0087h	0087h
50h	OT_FAULT_RESPONSE	Sets the converter response to an over temperature fault.	RW, NVM	Shutdown, do not restart	80h	80h
51h	OT_WARN_LIMIT	Sets the temperature, in degrees Celsius, of the unit at which it should indicate an Over temperature warning.	RW	105 °C (Ch A) 105 °C (Ch B)	0069h	0069h
55h	VIN_OV_FAULT_LIMIT	Set the voltage, in volts, of the unit at which it should indicate a Vin Over-voltage Fault.	RW, NVM	14.000 V	000Eh	
56h	VIN_OV_FAULT_RESPONSE	Instructs the device on what action to take in response to an input overvoltage fault.	R	Continue Uninterrupted	00h	
59h	VIN_UV_FAULT_LIMIT	Sets the value of the input voltage that causes an Input Under voltage Fault	RW, NVM	5.500 V	F80Bh	
5Ah	VIN_UV_FAULT_RESPONSE	Sets the converter response to an input undervoltage event	R	Shutdown, do not restart	C0h	

CMD	Command Name	Description	R/W, NVM	Default Behavior	Default Value	
					Ch. A (PAGE 0)	Ch. B PAGE 1
5Bh	IIN_OC_FAULT_LIMIT	Sets the value in amperes that causes the over current fault condition of the input current	RW, NVM	63.5 A	F87Fh	
5Ch	IIN_OC_FAULT_RESPONSE	Sets the converter response to input overcurrent events	R	Shutdown, do not restart	C0h	
5Dh	IIN_OC_WARN_LIMIT	Sets the value in amperes that causes the over current warning condition of the input current	RW, NVM	63.5 A	F87Fh	
60h	TON_DELAY	Sets the time, in milliseconds, from when a start condition is received (as programmed by the ON_OFF_CONFIG command) until the output voltage starts to rise.	RW, NVM	2.43 ms (Ch A) 2.43 ms (Ch B)	C26Eh	C26Eh
6Bh	PIN_OP_WARN_LIMIT	The PIN_OP_WARN_LIMIT command sets the value of the input power, in watts, that causes a warning that the input power is high	RW	450 W	08E1h	
78h	STATUS_BYTE	PMBus read-only status and flag bits.	RW	Current Status	N/A	N/A
79h	STATUS_WORD	PMBus read-only status and flag bits.	RW	Current Status	N/A	N/A
7Ah	STATUS_VOUT	PMBus read-only status and flag bits.	RW	Current Status	N/A	N/A
7Bh	STATUS_IOUT	PMBus read-only status and flag bits.	RW	Current Status	N/A	N/A
7Ch	STATUS_INPUT	PMBus read-only status and flag bits.	RW	Current Status	N/A	
7Dh	STATUS_TEMPERATURE	PMBus read-only status and flag bits.	RW	Current Status	N/A	N/A
7Eh	STATUS_CML	PMBus read-only status and flag bits.	RW	Current Status	N/A	
80h	STATUS_MFR_SPECIFIC	PMBus read-only status and flag bits.	RW	Current Status	N/A	N/A
88h	READ_VIN	Returns the input voltage in volts	R	Current Status	N/A	
89h	READ_IIN	Returns the input current in amperes	R	Current Status	N/A	
8Bh	READ_VOUT	Returns the output voltage in VID format	R	Current Status	N/A	N/A
8Ch	READ_IOUT	Returns the output current in amperes	R	Current Status	N/A	N/A
8Dh	READ_TEMPERATURE_1	Returns the highest power stage temperature in °C	R	Current Status	N/A	N/A
96h	READ_POUT	Returns the output power in Watts	R	Current Status	N/A	N/A
97h	READ_PIN	Returns the input power in Watts	R	Current Status	N/A	
98h	PMBUS_REVISION	Returns the version of the PMBus specification to which this device complies	R	PMBus 1.3 Part I, Part II	33h	
99h	MFR_ID	Loads the unit with bits that contain the manufacturer's ID	RW, NVM	Arbitrary NVM for user	0000h	
9Ah	MFR_MODEL	Loads the unit with bits that contain the manufacturer's model number	RW, NVM	Arbitrary NVM for user	0000h	
9Bh	MFR_REVISION	Loads the unit with bits that contain the manufacturer's model revision	RW, NVM	Arbitrary NVM for user	0400h	
9Dh	MFR_DATE	Loads the unit with bits that contain the manufacture date	RW, NVM	March 2017	1103h	
9Eh	MFR_SERIAL	NVM Checksum	R	NVM checksum	484D2979h	
ADh	IC_DEVICE_ID	Returns a number indicating the part number of the device	R	TPS53681	81h	
AEh	IC_DEVICE_REV	Returns a number indicating the device revision	R	Rev 1.0	00h	
B0h	USER_DATA_00	Used for batch NVM programming.	RW NVM	Current configuration	Factory Default Settings	
B1h	USER_DATA_01	Used for batch NVM programming.	RW NVM	Current configuration	Factory Default Settings	

CMD	Command Name	Description	R/W, NVM	Default Behavior	Default Value	
					Ch. A (PAGE 0)	Ch. B PAGE 1
B2h	USER_DATA_02	Used for batch NVM programming.	RW NVM	Current configuration	Factory Default Settings	
B3h	USER_DATA_03	Used for batch NVM programming.	RW NVM	Current configuration	Factory Default Settings	
B4h	USER_DATA_04	Used for batch NVM programming.	RW NVM	Current configuration	Factory Default Settings	
B5h	USER_DATA_05	Used for batch NVM programming.	RW NVM	Current configuration	Factory Default Settings	
B6h	USER_DATA_06	Used for batch NVM programming.	RW NVM	Current configuration	Factory Default Settings	
B7h	USER_DATA_07	Used for batch NVM programming.	RW NVM	Current configuration	Factory Default Settings	
B8h	USER_DATA_08	Used for batch NVM programming.	RW NVM	Current configuration	Factory Default Settings	
B9h	USER_DATA_09	Used for batch NVM programming.	RW NVM	Current configuration	Factory Default Settings	
BAh	USER_DATA_10	Used for batch NVM programming.	RW NVM	Current configuration	Factory Default Settings	
BBh	USER_DATA_11	Used for batch NVM programming.	RW NVM	Current configuration	Factory Default Settings	
BCh	USER_DATA_12	Used for batch NVM programming.	RW NVM	Current configuration	Factory Default Settings	
D0h	MFR_SPECIFIC_00	Configures per-phase overcurrent levels, current share thresholds, and other miscellaneous settings.	RW NVM	Misc. configuration, See register maps	0006h	3006h
D3h	MFR_SPECIFIC_03	Returns information regarding current imbalance warnings for each phase	R	Current status	N/A	N/A
D4h	MFR_SPECIFIC_04	Returns the output voltage for the active channel, in linear format	R	Current status	N/A	N/A
D5h	MFR_SPECIFIC_05	Used to trim the output voltage of the active channel, by applying an offset to the currently selected VID code.	RW NVM	0 mV offset (Ch A and Ch B)	00h	00h
D6h	MFR_SPECIFIC_06	Configures dynamic load line options for both channels, and selects Auto-DCM operation.	RW NVM	Misc. configuration, See register maps	0000h	0000h
D7h	MFR_SPECIFIC_07	Configures the internal loop compensation for both channels.	RW NVM	Misc. configuration, See to register maps	118Fh	118Fh
D8h	MFR_SPECIFIC_08	Used to identify catastrophic faults which occur first, and store this information to NVM	RW NVM	Current status	00h	00h
D9h	MFR_SPECIFIC_09	Used to configure non-linear transient performance enhancements such as undershoot reduction (USR)	RW NVM	Misc. configuration, See register maps	76C7h	06C7h
DAh	MFR_SPECIFIC_10	Used to configure input current sensing, and set the maximum output current	RW NVM	Misc. configuration, See register maps	C81Ah	001Ah
DBh	MFR_SPECIFIC_11	Boot-up VID code for each channel	RW NVM	VID 51d (Ch A) VID 51d (Ch B)	33h	33h
DCh	MFR_SPECIFIC_12	Used to configure input current sensing and other miscellaneous settings	RW NVM	Misc. configuration, See register maps	C704h	0700h
DDh	MFR_SPECIFIC_13	Used to configure output voltage slew rates, DAC stepsize, and other miscellaneous settings.	RW NVM	Misc. configuration, See register maps	8825h	0025h

CMD	Command Name	Description	R/W, NVM	Default Behavior	Default Value	
					Ch. A (PAGE 0)	Ch. B PAGE 1
DEh	MFR_SPECIFIC_14	Used to configure dynamic phase shedding, and compensation ramp amplitude, and dynamic ramp amplitude during USR, and different power states	RW NVM	Misc. configuration, See register maps	0005h	0005h
DFh	MFR_SPECIFIC_15	Used to configure dynamic phase shedding.	RW NVM	Misc. configuration, See register maps	1FFAh	0000h
E4h	MFR_SPECIFIC_20	Used to set the maximum operational phase number, on-the-fly.	RW NVM	Misc. configuration, See register maps	Hardware Configured	
F0h	MFR_SPECIFIC_32	Used to set the input over-power warning	RW	450 W	00E1h	
FAh	MFR_SPECIFIC_42	NVM Security	RW NVM	NVM Security Key	0000h	

#### 7.5.4 Commonly Used PMBus Commands

The following sections describe the most commonly used PMBus commands and their usage in the configuration, operation and testing of TPS53681 power solutions:

- [Voltage, Current, Power, and Temperature Readings](#)
- [Input Current Sense and Calibration](#)
- [Output Current Sense and Calibration](#)
- [Output Voltage Margin Testing](#)
- [Loop Compensation](#)
- [Converter Protection and Response](#)
- [Dynamic Phase Shedding](#)
- [NVM Programming](#)
- [NVM Security](#)
- [Black Box Fault Recording](#)
- [Board Identification and Inventory Tracking](#)
- [Status Reporting](#)

### 7.5.5 Voltage, Current, Power, and Temperature Readings

Using an internal ADC, the TPS53681 provides a full set of telemetry capabilities, allowing the user to read back critical information about the converter's input voltage, input current, input power, output voltage, output current, output power and temperature. The table below summarizes the available commands and their formats. Register maps for each command are included.

表 5. Telemetry Functions

Command	Description	Format	Units	Channel/Phase
READ_VIN	Input voltage telemetry	Linear	V	Shared, Channel A and B
READ_IIN	Input current telemetry	Linear	A	Shared, Channel A and B
READ_VOUT	Output voltage telemetry (VID format)	VID	VID Code	Per Channel
READ_IOUT	Output current telemetry	Linear	A	Per Channel and Per Phase
READ_TEMPERATURE_1	Power stage temperature telemetry	Linear	°C	Per Channel, Highest phase temperature only
READ_POUT	Output power telemetry	Linear	W	Per Channel
READ_PIN	Input power telemetry	Linear	W	Shared, Channel A and B
MFR_SPECIFIC_04	Output voltage telemetry (linear format)	Linear	V	Per Channel

#### 7.5.5.1 (88h) READ\_VIN

The READ\_VIN command returns the input voltage in volts. The two data bytes are formatted in the Linear Data format. The refresh rate is 1200  $\mu$ s. This command should be accessed through Read Word transactions, and is shared between channel A and channel B.

15	14	13	12	11	10	9	8
R	R	R	R	R	R	R	R
READ_VIN_EXP				READ_VIN_MAN			
7	6	5	4	3	2	1	0
R	R	R	R	R	R	R	R
READ_VIN_MAN							

LEGEND: R/W = Read/Write; R = Read only

图 15. READ\_VIN

表 6. READ\_VIN Register Field Descriptions

Bit	Field	Type	Reset	Description
15:11	READ_VIN_EXP	R	Current Status	Linear two's complement format exponent.
10:0	READ_VIN_MAN	R	Current Status	Linear two's complement format mantissa.

#### 7.5.5.2 (89h) READ\_IIN

The READ\_IIN command returns the input current in amperes. The refresh rate is 100  $\mu$ s. The two data bytes are formatted in the Linear Data format. This command should be accessed through Read Word transactions, and is shared between channel A and channel B.

15	14	13	12	11	10	9	8
R	R	R	R	R	R	R	R
READ_IIN_EXP				READ_IIN_MAN			
7	6	5	4	3	2	1	0
R	R	R	R	R	R	R	R
READ_IIN_MAN							

LEGEND: R/W = Read/Write; R = Read only

**图 16. READ\_IIN**

**表 7. READ\_IIN Register Field Descriptions**

Bit	Field	Type	Reset	Description
15:11	READ_IIN_EXP	R	Current Status	Linear two's complement format exponent.
10:0	READ_IIN_MAN	R	Current Status	Linear two's complement format mantissa.

### 7.5.5.3 (8Bh) READ\_VOUT

The READ\_VOUT command returns the actual, measured output voltage. The two data bytes are formatted in the VID Data format, and the refresh rate is 1200 us. This command should be accessed through Read Word transactions. READ\_VOUT is a paged register. In order to access READ\_VOUT command for channel A, PAGE must be set to 00h. In order to access READ\_VOUT register for channel B, PAGE must be set to 01h.

15	14	13	12	11	10	9	8
R	R	R	R	R	R	R	R
0	0	0	0	0	0	0	0
7	6	5	4	3	2	1	0
R	R	R	R	R	R	R	R
READ_VOUT_VID							

LEGEND: R/W = Read/Write; R = Read only

**图 17. READ\_VOUT**

**表 8. READ\_VOUT Register Field Descriptions**

Bit	Field	Type	Reset	Description
7:0	READ_VOUT_VID	R	Current Status	Output voltage, VID format

### 7.5.5.4 (8Ch) READ\_IOUT

The READ\_IOUT command returns the output current in amperes. The update rate is 100us. READ\_IOUT is a linear format command, and must be accessed through Read Word Transactions.

READ\_IOUT is a paged register. In order to access READ\_IOUT for channel A, PAGE must be set to 00h. In order to access the READ\_IOUT register for channel B, PAGE must be set to 01h. For simultaneous access of channels A and B, the PAGE command must be set to FFh. READ\_IOUT is also a phased register. Depending on the configuration of the design, for channel A, PHASE must be set to 00h to access Phase 1, 01h to access Phase 2, etc... PHASE must be set to FFh to access all phases simultaneously. PHASE may also be set to 80h to readback the total phase current (sum of all active phase currents for the active channel) measurement, as described in [Output Current Sense and Calibration](#). Note that READ\_IOUT is only a phased command for Channel A (PAGE 0).

15	14	13	12	11	10	9	8
R	R	R	R	R	R	R	R
READ_IOUT_EXP				READ_IOUT_MAN			
7	6	5	4	3	2	1	0
R	R	R	R	R	R	R	R
READ_IOUT_MAN							

LEGEND: R/W = Read/Write; R = Read only

**图 18. READ\_IOUT**

**表 9. READ\_IOUT Register Field Descriptions**

Bit	Field	Type	Reset	Description
15:11	READ_IOUT_EXP	R	Current Status	Linear two's complement format exponent.
10:0	READ_IOUT_MAN	R	Current Status	Linear two's complement format mantissa.

Attempts to write to this command results in invalid transactions. The device ignores the invalid data, sets the appropriate flags in STATUS\_CML and STATUS\_WORD, and asserts the PMB\_ALERT signal to notify the system host of an invalid transaction.

#### 7.5.5.5 (8Dh) READ\_TEMPERATURE\_1

The READ\_TEMPERATURE\_1 command returns the temperature in degree Celsius. The refresh rate is 1200 us.

READ\_TEMPERATURE\_1 is a linear format command. The READ\_TEMPERATURE\_1 command must be accessed through Read Word transactions.

READ\_TEMPERATURE\_1 is a paged register. In order to access READ\_TEMPERATURE\_1 command for channel A, PAGE must be set to 00h. In order to access READ\_TEMPERATURE\_1 register for channel B, PAGE must be set to 01h. For simultaneous access of channels A and B, the PAGE command must be set to FFh.

15	14	13	12	11	10	9	8
R	R	R	R	R	R	R	R
READ_TEMP_EXP				READ_TEMP_MAN			
7	6	5	4	3	2	1	0
R	R	R	R	R	R	R	R
READ_TEMP_MAN							

LEGEND: R/W = Read/Write; R = Read only

**图 19. READ\_TEMPERATURE\_1**

**表 10. READ\_TEMPERATURE\_1 Register Field Descriptions**

Bit	Field	Type	Reset	Description
15:11	READ_TEMP_EXP	R	Current Status	Linear two's complement format exponent.
10:0	READ_TEMP_MAN	R	Current Status	Linear two's complement format mantissa.

Attempts to write to this command results in invalid transactions. The device ignores the invalid data, sets the appropriate flags in STATUS\_CML and STATUS\_WORD, and asserts the PMB\_ALERT signal to notify the system host of an invalid transaction

**7.5.5.6 (96h) READ\_POUT**

The READ\_POUT command returns the calculated output power, in watts for the active channel. The refresh rate is 1200 μs.

READ\_POUT is a linear format command. The READ\_POUT command must be accessed through Read Word transactions.

READ\_POUT is a paged register. In order to access READ\_POUT command for channel A, PAGE must be set to 00h. In order to access READ\_POUT register for channel B, PAGE must be set to 01h. For simultaneous access of channels A and B, the PAGE command must be set to FFh.

15	14	13	12	11	10	9	8
R	R	R	R	R	R	R	R
READ_POUT_EXP				READ_POUT_MAN			
7	6	5	4	3	2	1	0
R	R	R	R	R	R	R	R
READ_POUT_MAN							

LEGEND: R/W = Read/Write; R = Read only

图 20. READ\_POUT

表 11. READ\_POUT Register Field Descriptions

Bit	Field	Type	Reset	Description
15:11	READ_POUT_EXP	R	Current Status	Linear two's complement format exponent.
10:0	READ_POUT_MAN	R	Current Status	Linear two's complement format mantissa.

Attempts to write to this command results in invalid transactions. The device ignores the invalid data, sets the appropriate flags in STATUS\_CML and STATUS\_WORD, and asserts the PMB\_ALERT signal to notify the system host of an invalid transaction

**7.5.5.7 (97h) READ\_PIN**

The READ\_PIN command returns the calculated input power. The refresh rate is 1200 μs.

READ\_PIN is a linear format command. The READ\_PIN command must be accessed through Read Word transactions.

The READ\_PIN command is shared between Channel A and Channel B. All transactions to this command will affect both channels regardless of the PAGE command.

15	14	13	12	11	10	9	8
R	R	R	R	R	R	R	R
READ_PIN_EXP				READ_PIN_MAN			
7	6	5	4	3	2	1	0
R	R	R	R	R	R	R	R
READ_PIN_MAN							

LEGEND: R/W = Read/Write; R = Read only

图 21. READ\_PIN

**表 12. READ\_PIN Register Field Descriptions**

Bit	Field	Type	Reset	Description
15:11	READ_PIN_EXP	R	Current Status	Linear two's complement format exponent.
10:0	READ_PIN_MAN	R	Current Status	Linear two's complement format mantissa.

**7.5.5.8 (D4h) MFR\_SPECIFIC\_04**

The MFR\_SPECIFIC\_04 command is used to return the output voltage for the active channel, in the **linear** format (READ\_VOUT uses VID format).

The MFR\_SPECIFIC\_04 command must be accessed through Read Word transactions. MFR\_SPECIFIC\_04 is a Linear format command.

MFR\_SPECIFIC\_04 is a paged register. In order to access MFR\_SPECIFIC\_04 command for channel A, PAGE must be set to 00h. In order to access the MFR\_SPECIFIC\_04 register for channel B, PAGE must be set to 01h.

15	14	13	12	11	10	9	8
R	R	R	R	R	R	R	R
VOUT_LIN_EXP					VOUT_LIN_MAN		
7	6	5	4	3	2	1	0
R	R	R	R	R	R	R	R
VOUT_LIN_MAN							

LEGEND: R/W = Read/Write; R = Read only

**图 22. MFR\_SPECIFIC\_04**
**表 13. MFR\_SPECIFIC\_04 Register Field Descriptions**

Bit	Field	Type	Reset	Description
15:11	VOUT_LIN_EXP	R	Current Status	Linear format two's complement exponent.
10:0	VOUT_LIN_MAN	R	Current Status	Linear format two's complement mantissa.

## 7.5.6 Input Current Sense and Calibration

The `READ_IIN` command reports the total input current to both channels. TPS53681 supports shunt or inductor DCR sensing. The section below describes how to calibrate the gain and offset of the sensed signal for accurate input current reporting. When input current sensing is not used, the `CSPIN` and `VIN_CSNIN` pins should be shorted together and connected to the power input voltage.

### 7.5.6.1 Measured Input Current Calibration

The TPS53681 reports input current via an integrated current sense interface on the `CSPIN` and `VIN_CSNIN` pins. A conceptual block diagram is shown in 图 23. This circuit must be calibrated to the value of the sense element,  $R_{SENSE}$  (e.g. shunt resistance or DCR), chosen. The values of  $A_{IIN}$ , `IIN_MAX` and `IIN_OFS` may be used to calibrate input current sensing. These settings are programmed using the `MFR_SPECIFIC_10` and `MFR_SPECIFIC_12` commands.



图 23. Measured Input Current Interface

The `IIN_RGAIN` bits in `MFR_SPECIFIC_12`, and the `IIN_GAIN_CTRL` bit in `MFR_SPECIFIC_10` select  $A_{IIN}$ , the gain of the analog input current sense interface. Refer to 表 18 for a table of supported  $A_{IIN}$  values. Note that the analog gain setting also corresponds to maximum allowed signal level and measured input current according to 表 14.

表 14.  $A_{IIN}$ , Input Current Sense Analog Gain

<code>IIN_GAIN_CTRL</code> ( <code>MFR_SPECIFIC_10</code> )	<code>IIN_RGAIN</code> ( <code>MFR_SPECIFIC_12</code> )	Effective $A_{IIN}$	Maximum Supported ( <code>CSPIN-VIN_CSNIN</code> ) Voltage	Maximum Supported Input Current Measurement
0b	00b	0.15 m $\Omega$	7.5 mV	50.0 A
0b	01b	0.25 m $\Omega$	12.5 mV	50.0 A
0b	10b	0.3 m $\Omega$	15.0 mV	50.0 A
0b	11b	0.5 m $\Omega$	25.0 mV	50.0 A
1b	00b	1.2 m $\Omega$	7.5 mV	6.25 A
1b	01b	2.0 m $\Omega$	12.5 mV	6.25 A
1b	10b	2.4 m $\Omega$	15.0 mV	6.25 A
1b	11b	4.0 m $\Omega$	25.0 mV	6.25 A

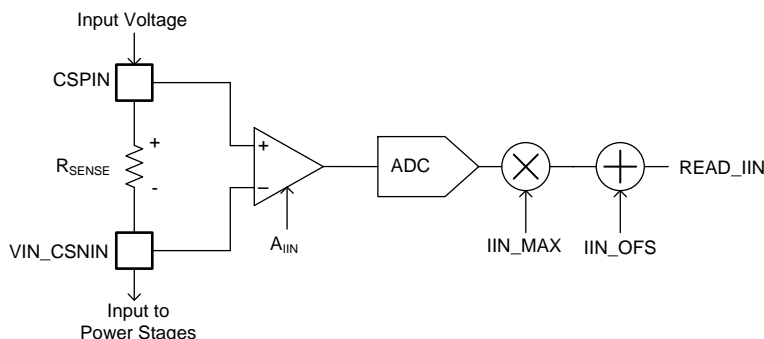
The `IIN_MAX` bits in `MFR_SPECIFIC_10` may also be used to digitally calibrate the gain of the input current reporting. Changing `IIN_MAX` allows the user to achieve fine gain calibration of the input current sense circuit, as well as support sense element resistor values other than those directly supported using  $A_{IIN}$ .

The nominal value of `IIN_MAX` is 50d. When the sense element resistance and  $A_{IIN}$  are equal, `IIN_MAX` should remain set to 50d. Changing `IIN_MAX` adjusts the current sense gain ratiometrically with respect to the nominal value of 50d. For example, changing `IIN_MAX` to 25d, reduces the effective gain by a factor of 2, and changing `IIN_MAX` to 10d, reduces the effective gain by a factor of 5. `IIN_MAX` has a maximum value of 64d. When using a sense element  $R_{SENSE}$  not equal to one of the supported  $A_{IIN}$  values, the `IIN_MAX` register must be adjusted according to 公式 3 to achieve accurate gain calibration.

$$IIN\_MAX = 50d \times \frac{A_{IIN}}{R_{SENSE}} \tag{3}$$

The IIN\_OFS bits in [MFR\\_SPECIFIC\\_10](#) may also be used to apply an offset to the sensed current in amperes.

**Example #1: 0.5 mΩ R<sub>SENSE</sub>**

With a 0.5 mΩ sense element value, for example, (V<sub>CSPIN</sub> - V<sub>VIN\_CSNIN</sub>) = 10 mV corresponds to 20 A current. Select the analog interface gain, A<sub>IIN</sub> = 0.5 mΩ, since this selection is available in [表 18](#), and do not apply any scaling via IIN\_MAX (set it to 50d).

1. Select the value of A<sub>IIN</sub> that most closely matches the target sense resistance. In this case, A<sub>IIN</sub> = 0.5 mΩ is available, which gives IIN\_RGAIN = 11b, and IIN\_GAIN\_CTRL = 0b.
2. Set IIN\_MAX = 50d × (0.5 mΩ / 0.5 mΩ) = 50d
3. Set IIN\_OFS = 0 A to start with, and tune as needed based on measurements.

**Example #2: 1.0 mΩ R<sub>SENSE</sub>**

With a 1.0 mΩ sense element value, for example, (V<sub>CSPIN</sub> - V<sub>VIN\_CSNIN</sub>) = 10 mV corresponds to 10 A current. With the analog interface gain, A<sub>IIN</sub> set to 0.5 mΩ, 10 mV would be interpreted as 20 A. Therefore apply IIN\_MAX = 50\*(0.5 mΩ / 1 mΩ) to reduce the effective gain by a factor of 2, so 10 mV is interpreted as 10 A.

1. Select the value of A<sub>IIN</sub> that most closely matches the target sense resistance. In this case, 1.0 mΩ is not directly available. Select A<sub>IIN</sub> = 0.5 mΩ, which gives IIN\_RGAIN = 11b, and IIN\_GAIN\_CTRL = 0b.
2. Set IIN\_MAX = 50d × (0.5 mΩ / 1.0 mΩ) = 25d
3. Set IIN\_OFS = 0 A to start with, and tune as needed based on measurements.

**7.5.6.2 (DAh) MFR\_SPECIFIC\_10**

The MFR\_SPECIFIC\_10 command is used to configure input current sensing, and set the maximum output current. These values are used for input current and output current telemetry.

The MFR\_SPECIFIC\_10 command must be accessed through Write Word/Read Word transactions. MFR\_SPECIFIC\_10 is a paged register. In order to access MFR\_SPECIFIC\_10 command for channel A, PAGE must be set to 00h. In order to access the MFR\_SPECIFIC\_10 register for channel B, PAGE must be set to 01h. Note that input current calibration is shared across both channels, but the configuration makes use of both PAGES.

15	14	13	12	11	10	9	8
RW	RW	RW	RW	R	RW	RW	RW
IIN_MAX (PAGE 0, bits 15:8) IIN_GAIN_CTRL (PAGE 1, bit 13) IIN_OFS (PAGE 1, bits 12:8)							
7	6	5	4	3	2	1	0
RW	RW	RW	RW	RW	RW	RW	RW
IOUT_MAX (PAGE 0, PAGE 1)							

LEGEND: R/W = Read/Write; R = Read only

**图 24. MFR\_SPECIFIC\_10**

**表 15. MFR\_SPECIFIC\_10 Register Field Descriptions**

Bit	Field	Type	Reset	Description
15:8	IIN_MAX (PAGE 0)	RW	NVM	Maximum IIN setting. LSB = 0.25 A. Valid values range from 0 A to 63.75 A.
13	IIN_GAIN_CTRL (PAGE 1)	RW	NVM	Used to increase the effective IIN_RGAIN. See <a href="#">MFR_SPECIFIC_12</a> for more information.
12:8	IIN_OFS (PAGE 1)	RW	NVM	Input current sense offset calibration. See <a href="#">表 16</a> .
7:0	IOUT_MAX	RW	NVM	Sets the maximum output current for each channel (PAGE 0 for channel A, PAGE 1 for channel B). LSB = 1 A.

**表 16. Input Current Offset Calibration Settings**

IIN_OFS (hex)	IIN Offset (A)
00h	0
01h	0.1
02h	0.2
03h	0.3
04h	0.4
05h	0.5
06h	0.6
07h	0.7
08h	0.8
09h	0.9
0Ah	1.0
0Bh	1.1
0Ch	1.2
0Dh	1.3
0Eh	1.4
0Fh	1.5
10h	-1.6
11h	-1.5
12h	-1.4
13h	-1.3
14h	-1.2
15h	-1.1
16h	-1.0
17h	-0.9
18h	-0.8
19h	-0.7
1Ah	-0.6
1Bh	-0.5
1Ch	-0.4
1Dh	-0.3
1Eh	-0.2
1Fh	-0.1

**7.5.6.3 (DCh) MFR\_SPECIFIC\_12**

The MFR\_SPECIFIC\_12 command is used to configure input current sensing.

The MFR\_SPECIFIC\_12 command must be accessed through Write Word/Read Word transactions. MFR\_SPECIFIC\_12 is a paged register, but all relevant configuration bits are associated with PAGE 0. PAGE should be set to 00h when accessing MFR\_SPECIFIC\_12.

15	14	13	12	11	10	9	8
RW	RW	R	RW	RW	RW	RW	RW
IIN_RGAIN		0	TI_INTERNAL				
7	6	5	4	3	2	1	0
RW	RW	RW	RW	RW	RW	RW	RW
TI_INTERNAL							

LEGEND: R/W = Read/Write; R = Read only

**图 25. MFR\_SPECIFIC\_12**
**表 17. MFR\_SPECIFIC\_12 Register Field Descriptions**

Bit	Field	Type	Reset	Description
15:14	IIN_RGAIN (PAGE 0 only)	RW	NVM	Input shunt resistance value. Combined with IIN_RGAIN, IIN_OFS, IIN_MAX to calibrate measured input current sensing. Note that finer adjustments can be made using IIN_MAX.
12:0	TI_INTERNAL	RW	NVM	TI Internal bits. These bits are writeable, but should not be modified from their factory default setting.

**表 18.  $A_{IIN}$ , Input Current Sense Analog Gain<sup>(1)</sup>**

IIN_GAIN_CTRL ( MFR_SPECIFIC_10)	IIN_RGAIN ( MFR_SPECIFIC_12)	Effective $A_{IIN}$
0b	00b	0.15 m $\Omega$
0b	01b	0.25 m $\Omega$
0b	10b	0.3 m $\Omega$
0b	11b	0.5 m $\Omega$
1b	00b	1.2 m $\Omega$
1b	01b	2.0 m $\Omega$
1b	10b	2.4 m $\Omega$
1b	11b	4.0 m $\Omega$

(1) See Also 表 14

**表 19. Maximum Temperature Settings**

TMAX (binary)	Maximum Temperature (°C)
000b	90
001b	95
010b	100
011b	105
100b	110
101b	115
110b	120
111b	125

## 7.5.7 Output Current Sense and Calibration

The READ\_IOUT command may be used to read the individual phase currents, and the total channel current.

### 7.5.7.1 Reading Individual Phase Currents

Using the PAGE and PHASE commands, the TPS53681 can be configured to return output current information for each individual phase. The examples below demonstrate this process:

#### Example #1: Read back the output current of Channel A, First Phase

1. Select Channel A. Write PAGE to 00h
2. Select first phase. Write PHASE to 00h
3. Read READ\_IOUT

#### Example #2: Read back the output current of Channel B, Second Phase

1. Select Channel B. Write PAGE to 01h
2. Select second phase. Write PHASE to 01h
3. Read READ\_IOUT

#### 7.5.7.1.1 Reading Total Current

When the PHASE command is set to 80h, the TPS53681 device is configured to return the total channel current (sum of individual phase currents) in response to the READ\_IOUT command.

#### Example: Read the Total Output Current of Channel A

1. Select Channel A. Write PAGE to 00h
2. Select total current measurement. Write PHASE to 80h
3. Read READ\_IOUT

#### 7.5.7.1.2 Calibrating Current Measurements

The IOUT\_CAL\_GAIN and IOUT\_CAL\_OFFSET commands are available to allow the user to fine-tune current measurements. Setting the PHASE command to 80h also allows the total current measurement to be calibrated in a similar manner. The TI power stage devices supply current information to the controller device, using the CSPx and CSNx pins, with a scale of 5 mV/A. The IOUT\_CAL\_GAIN command may be used to fine-tune the scaling inside the controller to account for any gain mismatch. Likewise, the IOUT\_CAL\_OFFSET command may be used to apply an offset to the controller current measurements, to null offset errors.

#### Example: Calibrating Total Output Current Measurement

1. Select Channel A. Write PAGE to 00h
2. Select the total current. Write PHASE to 80h
3. First read back READ\_IOUT under two known output currents:
  1. For this example, apply a load of 60 A
  2. Read back READ\_IOUT, record the value. For this example, consider that READ\_IOUT gives 59.0 A.
  3. For this example, apply a load of 120 A
  4. Read back READ\_IOUT, record the value. For this example, consider that READ\_IOUT gives 119.6 A
4. Calculate the gain error:
  1. The current reading increased  $(119.6 \text{ A} - 59.0 \text{ A}) = 60.6 \text{ A}$  for a 60 A current step
  2. Hence, the current reading gain is  $(60.6 \text{ A} / 60 \text{ A}) = 1.01$ .
  3. Ideally, the current reading gain is 1.00, so the readings show a +1% gain error.
5. Apply IOUT\_CAL\_GAIN to correct the gain error:
  1. The gain error is +1%, and the nominal current sense gain is 5 mΩ, so the current sense gain must be lowered by 1%.
  2. Hence, the IOUT\_CAL\_GAIN should be programmed to  $5 \text{ m}\Omega \times (1-1\%) = 4.95 \text{ m}\Omega$
  3. Referring to 表 21 the closest acceptable value is 4.953125 mΩ, or D13Dh.
  4. Write IOUT\_CAL\_GAIN to D13Dh.

6. Determine the offset error at a given point:
  1. Apply a known load. In this example, 90 A.
  2. Read back READ\_IOUT. For this example, consider that READ\_IOUT gives 89 A.
  3. Hence, the offset error is (89 A - 90A) = -1A.
7. Apply IOUT\_CAL\_OFFSET to correct the gain error
  1. The offset error is -1 A, so an offset of +1 A must be applied.
  2. Refer to [表 24](#), the closest available value of IOUT\_CAL\_OFFSET is +1.0 A or E808h
  3. Write IOUT\_CAL\_OFFSET to E808h.
8. Issue STORE\_DEFAULT\_ALL to commit the calibration values to NVM.

**7.5.7.2 (38h) IOUT\_CAL\_GAIN**

The IOUT\_CAL\_GAIN command is used to set the ratio of the voltage at the current sense pins to the sensed current, in mΩ.

IOUT\_CAL\_GAIN is a linear format command. The IOUT\_CAL\_GAIN command must be accessed through Read Word/Write Word transactions.

IOUT\_CAL\_GAIN is a paged register. In order to access IOUT\_CAL\_GAIN for channel A, PAGE must be set to 00h. In order to access the IOUT\_CAL\_GAIN register for channel B, PAGE must be set to 01h. For simultaneous access of channels A and B, the PAGE command must be set to FFh. IOUT\_CAL\_GAIN is also a phased register. Depending on the configuration of the design, for channel A, PHASE must be set to 00h to access Phase 1, 01h to access Phase 2, etc... PHASE must be set to FFh to access all phases simultaneously. PHASE may also be set to 80h to apply IOUT\_CAL\_GAIN to the total phase current (sum of all active phases for the current channel) measurement, as described in [Output Current Sense and Calibration](#).

15		14		13		12		11		10		9		8	
R		R		R		R		R		RW		RW		RW	
IOCG_EXP										IOCG_MAN					
7		6		5		4		3		2		1		0	
RW		RW		RW		RW		RW		RW		RW		RW	
IOCG_MAN															

LEGEND: R/W = Read/Write; R = Read only

**图 26. IOUT\_CAL\_GAIN**

**表 20. IOUT\_CAL\_GAIN Register Field Descriptions**

Bit	Field	Type	Reset	Description
15:11	IOCG_EXP	R	11010b	Linear two's complement exponent, -6. LSB = 0.015625 mΩ
10:0	IOCG_MAN	RW	NVM	Linear two's complement mantissa. See the table of acceptable values below.

**表 21. Acceptable Values of IOUT\_CAL\_GAIN**

IOUT_CAL_GAIN (hex)	Current Sense Gain (mΩ)
D131h	4.765625
D132h	4.78125
D133h	4.796875
D134h	4.8125
D135h	4.828125
D136h	4.84375
D137h	4.859375
D138h	4.875
D139h	4.890625
D13Ah	4.90625

**表 21. Acceptable Values of IOUT\_CAL\_GAIN (接下页)**

IOUT_CAL_GAIN (hex)	Current Sense Gain (mΩ)
D13Bh	4.921875
D13Ch	4.9375
D13Dh	4.953125
D13Eh	4.96875
D13Fh	4.984375
D140h	5
D141h	5.015625
D142h	5.03125
D143h	5.046875
D144h	5.0625
D145h	5.078125
D146h	5.09375
D147h	5.109375
D148h	5.125
D149h	5.140625
D14Ah	5.15625
D14Bh	5.171875
D14Ch	5.1875
D14Dh	5.203125
D14Eh	5.21875
D14Fh	5.234375
D150h	5.25

Attempts to write any value other than those specified above results in invalid transactions. The device ignores the invalid data, sets the appropriate flags in STATUS\_CML and STATUS\_WORD, and asserts the PMB\_ALERT signal to notify the system host of an invalid transaction.

### 7.5.7.3 (39h) IOUT\_CAL\_OFFSET

The IOUT\_CAL\_OFFSET command is used to compensate for offset errors in the READ\_IOUT command, in Amperes.

IOUT\_CAL\_OFFSET is a linear format command. The IOUT\_CAL\_OFFSET command must be accessed through Read Word/Write Word transactions

IOUT\_CAL\_OFFSET is a paged register. In order to access IOUT\_CAL\_OFFSET for channel A, PAGE must be set to 00h. In order to access the IOUT\_CAL\_OFFSET register for channel B, PAGE must be set to 01h. For simultaneous access of channels A and B, the PAGE command must be set to FFh. IOUT\_CAL\_OFFSET is also a phased register. Depending on the configuration of the design, for channel A, PHASE must be set to 00h to access Phase 1, 01h to access Phase 2, etc... PHASE must be set to FFh to access all phases simultaneously. PHASE may also be set to 80h to apply IOUT\_CAL\_OFFSET to the total phase current (sum of all active phases for the current channel) measurement, as described in [Output Current Sense and Calibration](#).

15	14	13	12	11	10	9	8
R	R	R	R	R	RW	RW	RW
IOCOS_EXP					IOCOS_MAN		
7	6	5	4	3	2	1	0
RW	RW	RW	RW	RW	RW	RW	RW
IOCOS_MAN							

LEGEND: R/W = Read/Write; R = Read only

**图 27. IOUT\_CAL\_OFFSET**
**表 22. IOUT\_CAL\_OFFSET Register Field Descriptions**

Bit	Field	Type	Reset	Description
15:11	IOCOS_EXP	R	11101b	Linear two's complement exponent, -3. LSB = 0.125 A
10:0	IOCOS_MAN	RW	NVM	Linear two's complement mantissa. See the table of acceptable values below. Note that there is a different set of acceptable values for individual phases (e.g. PHASE = 00h - 05h, and FFh) vs. the total current telemetry function (e.g. PHASE = 80h). See <a href="#">Output Current Sense and Calibration</a> for more information.

**表 23. Acceptable Values of IOUT\_CAL\_OFFSET (Individual Phases, PHASE # 80h)**

IOUT_CAL_OFFSET (hex)	Current Sense Offset (A)
E800h	0.00
E801h	0.125
E802h	0.25
E803h	0.375
E804h	0.5
E805h	0.625
E806h	0.75
E807h	0.875
E808h	1.0
EFF9h	-0.875
EFFAh	-0.75
EFFBh	-0.625
EFFCh	-0.5
EFFDh	-0.375
EFFEh	-0.25
EFFFh	-0.125

**表 24. Acceptable Values of IOUT\_CAL\_OFFSET (Total Current, PHASE = 80h)**

IOUT_CAL_OFFSET (hex)	Current Sense Offset (A)
E800h	0.00
E802h	0.25
E804h	0.5
E806h	0.75
E808h	1.0
E80Ah	1.25
E80Ch	1.5
E80Eh	1.75
E810h	2.0
E812h	2.25
E814h	2.5
E816h	2.75
E818h	3.0
E81Ah	3.25
E81Ch	3.5
E81Eh	3.75
E820h	4.0

**表 24. Acceptable Values of IOUT\_CAL\_OFFSET (Total Current, PHASE = 80h)**  
(接下页)

IOUT_CAL_OFFSET (hex)	Current Sense Offset (A)
EFE2h	-3.75
EFE4h	-3.5
EFE6h	-3.25
EFE8h	-3.0
EFEAh	-2.75
EFECh	-2.5
EFEEh	-2.25
EFF0h	-2.0
EFF2h	-1.75
EFF4h	-1.5
EFF6h	-1.25
EFF8h	-1.0
EFFAh	-0.75
EFFCh	-0.5
EFFEh	-0.25

Attempts to write any value other than those specified above results in invalid transactions. The device ignores the invalid data, sets the appropriate flags in STATUS\_CML and STATUS\_WORD, and asserts the PMB\_ALERT signal to notify the system host of an invalid transaction.

### 7.5.8 Output Voltage Margin Testing

The TPS53681 provides several commands to enable voltage margin testing.

The upper two MARGIN bits in the OPERATION command can be used to toggle the active channel between three states:

1. **Margin None (MARGIN = 0000b)**. The output voltage target is equal to VOUT\_COMMAND.
2. **Margin Low (MARGIN = 01xxb)**. The output voltage target is equal to VOUT\_MARGIN\_LOW.
3. **Margin High (MARGIN = 10xxb)**. The output voltage target is equal to VOUT\_MARGIN\_HIGH.

In order to use OPERATION, the active channel must be configured for to respect the OPERATION command, via ON\_OFF\_CONFIG. Output voltage transitions will occur at the slew rate defined by VOUT\_TRANSITION\_RATE.

The lower two MARGIN bits in the OPERATION command select overvoltage/undervoltage fault handling during margin testing:

1. **Ignore Faults (MARGIN = xx01b)** . Overvoltage/Undervoltage faults will not trigger during margin tests.
2. **Act on Faults (MARGIN = xx10b)**. Overvoltage/Undervoltage faults will trigger during margin tests.

#### Example: Output Voltage Margin Testing (Ignore Faults)

1. Write to the PAGE command to select the desired channel (E.g. PAGE = 00h for channel A).
2. Write VOUT\_COMMAND to the desired VID code during Margin None operation.
3. Write VOUT\_MARGIN\_LOW to the desired VID code during Margin Low operation.
4. Write VOUT\_MARGIN\_HIGH to the desired VID code during Margin High operation.
5. Set the CMD bit in ON\_OFF\_CONFIG to 1b to ensure the device is configured to respect the OPERATION command.
6. Margin None. Write OPERATION to 80h.
7. Margin Low. Write OPERATION to 94h.
8. Margin High. Write OPERATION to A4h.

#### 7.5.8.1 (01h) OPERATION

The OPERATION command is used to turn the device output on or off in conjunction with the input from the AVR\_EN pin for channel A, and BEN pin for channel B, according to the configuration of the ON\_OFF\_CONFIG command. It is also used to set the output voltage to the upper or lower MARGIN levels.

OPERATION is a paged register. In order to access OPERATION command for channel A, PAGE must be set to 00h. In order to access OPERATION register for channel B, PAGE must be set to 01h. For simultaneous access of channels A and B, the PAGE command must be set to FFh.

The OPERATION command must be accessed through Read Byte/Write Byte transactions.

7	6	5	4	3	2	1	0
RW	R	RW	RW	RW	RW	RW	RW
ON	0	MARGIN				0	0

LEGEND: R/W = Read/Write; R = Read only

图 28. OPERATION

表 25. OPERATION Register Field Descriptions

Bit	Field	Type	Reset	Description
7	ON	RW	0b	Enable/disable power conversion for the currently selected channel(s) according to the PAGE command, when the ON_OFF_CONFIG command is configured to require input from the ON bit for output control. Note that there may be several other requirements that must be satisfied before the currently selected channel(s) can begin converting power (e.g. input voltages above UVLO thresholds, AVR_EN/BEN pins high if required by ON_OFF_CONFIG, etc...) 0b: Disable power conversion 1b: Enable power conversion
5:2	MARGIN	RW	0000b	Set the output voltage to either the value selected by the VOUT_MARGIN_HIGH or MARGIN_LOW commands, for the currently selected channel(s), according to the PAGE command. 0000b: Margin Off. Output voltage is set to the value of VOUT_COMMAND 0101b: Margin Low (Ignore Fault). Output voltage is set to the value of VOUT_MARGIN_LOW. 0110b: Margin Low (Act on Fault). Output voltage is set to the value of VOUT_MARGIN_LOW. 1001b: Margin High (Ignore Fault). Output voltage is set to the value of VOUT_MARGIN_HIGH 1010b: Margin High (Act on Fault). Output voltage is set to the value of VOUT_MARGIN_HIGH.
1:0	0	RW	00b	These bits are writeable but should always be set to 00b.

Note that the VOUT\_MAX\_WARN bit in STATUS\_VOUT can be caused by a margin operation, if "Act on Fault" is selected, and the VOUT\_MARGIN\_HIGH/VOUT\_MARGIN\_LOW value loaded by the margin operation exceeds the value of VOUT\_COMMAND.

7.5.8.2 (21h) VOUT\_COMMAND

VOUT\_COMMAND is used to set the output voltage of the active PAGE.

VOUT\_COMMAND is a VID format command. VOUT\_COMMAND command must be accessed through Read Word/Write Word transactions.

VOUT\_COMMAND is a paged register. In order to access VOUT\_COMMAND for channel A, PAGE must be set to 00h. In order to access the VOUT\_COMMAND register for channel B, PAGE must be set to 01h. For simultaneous access of channels A and B, the PAGE command must be set to FFh.

15	14	13	12	11	10	9	8
R	R	R	R	R	R	R	R
0	0	0	0	0	0	0	0
7	6	5	4	3	2	1	0
RW	RW	RW	RW	RW	RW	RW	RW
VOUT_CMD_VID							

LEGEND: R/W = Read/Write; R = Read only

图 29. VOUT\_COMMAND

表 26. VOUT\_COMMAND Register Field Descriptions

Bit	Field	Type	Reset	Description
7:0	VOUT_CMD_VID	RW	NVM	Used to set the commanded VOUT. Cannot be set to a level above the value set by VOUT_MAX.

### 7.5.8.3 (26h) VOUT\_MARGIN\_LOW

The VOUT\_MARGIN\_LOW command loads the unit with the voltage to which the output is to be changed when the OPERATION command is set to “Margin Low”.

VOUT\_MARGIN\_LOW is a VID format command. The VOUT\_MARGIN\_LOW command must be accessed through Read Word/Write Word transactions.

VOUT\_MARGIN\_LOW is a paged register. In order to access VOUT\_MARGIN\_LOW for channel A, PAGE must be set to 00h. In order to access the VOUT\_MARGIN\_LOW register for channel B, PAGE must be set to 01h. For simultaneous access of channels A and B, the PAGE command must be set to FFh.

15	14	13	12	11	10	9	8
R	R	R	R	R	R	R	R
0	0	0	0	0	0	0	0
7	6	5	4	3	2	1	0
RW	RW	RW	RW	RW	RW	RW	RW
VOUT_MARGL_VID							

LEGEND: R/W = Read/Write; R = Read only

**图 30. VOUT\_MARGIN\_LOW**

**表 27. VOUT\_MARGIN\_LOW Register Field Descriptions**

Bit	Field	Type	Reset	Description
7:0	VOUT_MARGL_VID	RW	00h	Used to set the output voltage to be loaded when the active PAGE is set to Margin Low, in VID format.

### 7.5.8.4 (25h) VOUT\_MARGIN\_HIGH

The VOUT\_MARGIN\_HIGH command loads the unit with the voltage to which the output is to be changed when the OPERATION command is set to “Margin High”.

VOUT\_MARGIN\_HIGH is a VID format command. The VOUT\_MARGIN\_HIGH command must be accessed through Read Word/Write Word transactions.

VOUT\_MARGIN\_HIGH is a paged register. In order to access VOUT\_MARGIN\_HIGH for channel A, PAGE must be set to 00h. In order to access the VOUT\_MARGIN\_HIGH register for channel B, PAGE must be set to 01h. For simultaneous access of channels A and B, the PAGE command must be set to FFh.

15	14	13	12	11	10	9	8
R	R	R	R	R	R	R	R
0	0	0	0	0	0	0	0
7	6	5	4	3	2	1	0
RW	RW	RW	RW	RW	RW	RW	RW
VOUT_MARGH_VID							

LEGEND: R/W = Read/Write; R = Read only

**图 31. VOUT\_MARGIN\_HIGH**

**表 28. VOUT\_MARGIN\_HIGH Register Field Descriptions**

Bit	Field	Type	Reset	Description
7:0	VOUT_MARGH_VID	RW	00h	Used to set the output voltage to be loaded when the active PAGE is set to Margin High, in VID format.

### 7.5.9 Loop Compensation

The TPS53681 provides several options for tuning the output voltage feedback and response to transients. These may be configured by programming the [MFR\\_SPECIFIC\\_07](#), [VOUT\\_DROOP](#), and [MFR\\_SPECIFIC\\_14](#). Several such parameters may be configured through these commands:

- **DC Load Line** - Selects the DC shift in output voltage corresponding to increased output current. The DC load line affects both the final value the output voltage settles to, as well as the settling time. Use the [VOUT\\_DROOP](#) command to select the DC load line.
- **Integration Time Constant** - In order to maintain DC accuracy, the control loop includes an integration stage. Use [MFR\\_SPECIFIC\\_07](#) to select the integration time constant.
- **Integration Path Gain** - The gain of the integration and AC paths may be selected independently. The AC and DC gains both affect the small-signal bandwidth of the converter. Use [MFR\\_SPECIFIC\\_07](#) to select the integration path gain.
- **AC Load Line** - Selects the AC response to output voltage error. The AC load line affects the settling and response time following a load transient event. Use the [MFR\\_SPECIFIC\\_07](#) command to select the AC load line.
- **AC Path Gain** - The gain of the integration and AC paths may be selected independently. The AC and DC gains both affect the small-signal bandwidth of the converter. Use [MFR\\_SPECIFIC\\_07](#) to select the AC path gain.
- **Ramp Amplitude** - Smaller ramp settings result in faster response, but may also lead to increased frequency jitter. Likewise, large ramp settings result in lower frequency jitter, but may be slightly slower to respond to changing conditions. The ramp setting also affects the small-signal bandwidth of the converter. Use [MFR\\_SPECIFIC\\_14](#) to select the ramp height setting.

#### 7.5.9.1 (D7h) MFR\_SPECIFIC\_07

The MFR\_SPECIFIC\_07 command is used to configure the internal loop compensation for both channels. The MFR\_SPECIFIC\_07 command must be accessed through Write Word/Read Word transactions.

MFR\_SPECIFIC\_07 is a paged register. In order to access MFR\_SPECIFIC\_07 command for channel A, PAGE must be set to 00h. In order to access the MFR\_SPECIFIC\_07 register for channel B, PAGE must be set to 01h.

15	14	13	12	11	10	9	8
R	R	RW	RW	RW	RW	RW	RW
0	0	INT_GAIN		INT_TC			
7	6	5	4	3	2	1	0
RW	RW	RW	RW	RW	RW	RW	RW
AC_GAIN		ACLL					

LEGEND: R/W = Read/Write; R = Read only

图 32. MFR\_SPECIFIC\_07

表 29. MFR\_SPECIFIC\_07 Register Field Descriptions

Bit	Field	Type	Reset	Description
15:14	Not used	R	0	Not used and set to 0.
13:12	INT_GAIN	RW	NVM	Integration path gain. See <a href="#">表 30</a> .
11:8	INT_TC	RW	NVM	Integration time constant. See <a href="#">表 31</a> .
7:6	AC_GAIN	RW	NVM	AC path gain. See <a href="#">表 32</a> .
5:0	ACLL	RW	NVM	AC Load Line. See <a href="#">表 33</a> .

表 30. Integration path gain settings

INT_GAIN (binary)	Integration path gain (V/V)
00b	2 × AC_GAIN
01b	1 × AC_GAIN
10b	0.66 × AC_GAIN

**表 30. Integration path gain settings (接下页)**

INT_GAIN (binary)	Integration path gain (V/V)
11b	$0.5 \times AC\_GAIN$

**表 31. Integration time constant settings**

INT_TC (binary)	Time constant ( $\mu$ s)
0000b	5
0001b	10
0010b	15
0011b	20
0100b	25
0101b	30
0110b	35
0111b	40
1000b	1
1001b	2
1010b	3
1011b	4
1100b	5
1101b	6
1110b	7
1111b	8

**表 32. AC path gain settings**

AC_GAIN (binary)	AC path gain (V/V)
00b	1
01b	1.5
10b	2
11b	0.5

**表 33. AC Load line settings**

Bin	ACLL (hex)	AC Load line ( $m\Omega$ )
0	00h	0.0000
1	01h	0.1250
2	02h	0.2500
3	03h	0.3125
4	04h	0.3750
5	05h	0.4375
6	06h	0.5000
7	07h	0.5625
8	08h	0.6250
9	09h	0.7500
10	0Ah	0.7969
11	0Bh	0.8125
12	0Ch	0.8281
13	0Dh	0.8438
14	0Eh	0.8594
15	0Fh	0.8750
16	10h	0.8906

**表 33. AC Load line settings (接下页)**

Bin	ACLL (hex)	AC Load line (mΩ)
17	11h	0.9063
18	12h	0.9219
19	13h	0.9375
20	14h	0.9531
21	15h	0.9688
22	16h	0.9844
23	17h	1.000
24	18h	1.0156
25	19h	1.0313
26	1Ah	1.0469
27	1Bh	1.0625
28	1Ch	1.1250
29	1Dh	1.2500
30	1Eh	1.3750
31	1Fh	1.5000
32	20h	1.6250
33	21h	1.7500
34	22h	1.8750
35	23h	1.9375
36	24h	2.000
37	25h	2.0625
38	26h	2.1250
39	27h	2.1875
40	28h	2.2500
41	29h	2.375
42	2Ah	2.4218
43	2Bh	2.4375
44	2Ch	2.4531
45	2Dh	2.4687
46	2Eh	2.4843
47	2Fh	2.5000
48	30h	2.5156
49	31h	2.5312
50	32h	2.5468
51	33h	2.5625
52	34h	2.5781
53	35h	2.5937
54	36h	2.609
55	37h	2.625
56	38h	2.6406
57	39h	2.6562
58	3Ah	2.6718
59	3Bh	2.6875
60	3Ch	2.750
61	3Dh	2.875
62	3Eh	3.000
63	3Fh	3.125

### 7.5.9.2 (28h) VOUT\_DROOP

The VOUT\_DROOP command sets the rate, in mV/A (mΩ) at which the output voltage decreases (or increases) with increasing (or decreasing) output current for use with adaptive voltage positioning. This is also referred to as the DC Load Line (DCLL).

VOUT\_DROOP is a linear format command. The VOUT\_DROOP command must be accessed through Read Word/Write Word transactions.

VOUT\_DROOP is a paged register. In order to access VOUT\_DROOP for channel A, PAGE must be set to 00h. In order to access the VOUT\_DROOP register for channel B, PAGE must be set to 01h. For simultaneous access of channels A and B, the PAGE command must be set to FFh.

15	14	13	12	11	10	9	8
R	R	R	R	R	RW	RW	RW
VDROOP_EXP				VDROOP_MAN			
7	6	5	4	3	2	1	0
RW	RW	RW	RW	RW	RW	RW	RW
VDROOP_MAN							

LEGEND: R/W = Read/Write; R = Read only

图 33. VOUT\_DROOP

表 34. VOUT\_DROOP Register Field Descriptions

Bit	Field	Type	Reset	Description
15:11	VDROOP_EXP	R	11010b	Linear two's complement fixed exponent, -6. LSB = 0.015625 mΩ
10:0	VDROOP_MAN	RW	NVM	Linear two's complement mantissa. See table of acceptable values below, note that Channel A and Channel B support different acceptable values of VOUT_DROOP.

The table below summarizes the acceptable values of VOUT\_DROOP for channel A and channel B. Attempts to write any value other than those specified below will be treated as invalid data - invalid data will be ignored, the appropriate flags in STATUS\_CML and STATUS\_WORD will be set, and the PMB\_ALERT will be asserted to notify the system host of an invalid transaction.

表 35. Acceptable VOUT\_DROOP Values

Bin	VOUT_DROOP (hex)	Supported by Channel A	Supported by Channel B	DC Load Line (mΩ)
0	D000h	Yes	Yes	0
1	D008h	Yes	Yes	0.125
2	D010h	Yes	Yes	0.25
3	D014h	Yes	Yes	0.3125
4	D018h	Yes	Yes	0.375
5	D01Ch	Yes	Yes	0.4375
6	D020h	Yes	Yes	0.5
7	D024h	Yes	Yes	0.5625
8	D028h	Yes	Yes	0.625
9	D030h	Yes	Yes	0.7031
10	D033h	Yes	Yes	0.7969
11	D034h	Yes	Yes	0.8125
12	D035h	Yes	Yes	0.8281
13	D036h	Yes	Yes	0.8438
14	D037h	Yes	Yes	0.8594
15	D038h	Yes	Yes	0.875
16	D039h	Yes	No	0.8906

**表 35. Acceptable VOUT\_DROOP Values (接下页)**

Bin	VOUT_DROOP (hex)	Supported by Channel A	Supported by Channel B	DC Load Line (mΩ)
17	D03Ah	Yes	No	0.9063
18	D03Bh	Yes	No	0.9219
19	D03Ch	Yes	No	0.9375
20	D03Dh	Yes	No	0.9531
21	D03Eh	Yes	No	0.9688
22	D03Fh	Yes	No	0.9844
23	D040h	Yes	No	1
24	D041h	Yes	No	1.0156
25	D042h	Yes	No	1.0313
26	D043h	Yes	No	1.0469
27	D044h	Yes	No	1.0625
28	D048h	Yes	No	1.125
29	D050h	Yes	No	1.25
30	D058h	Yes	No	1.375
31	D060h	Yes	No	1.5
32	D068h	Yes	No	1.625
33	D070h	Yes	No	1.75
34	D078h	Yes	No	1.875
35	D07Ch	Yes	No	1.9375
36	D080h	Yes	No	2
37	D084h	Yes	No	2.0625
38	D088h	Yes	No	2.125
39	D08Ch	Yes	No	2.1875
40	D090h	Yes	No	2.25
41	D098h	Yes	No	2.328
42	D09Bh	Yes	No	2.4218
43	D09Ch	Yes	No	2.4375
44	D09Dh	Yes	No	2.4531
45	D09Eh	Yes	No	2.4687
46	D09Fh	Yes	No	2.4843
47	D0A0h	Yes	No	2.5
48	D0A1h	Yes	No	2.5156
49	D0A2h	Yes	No	2.5312
50	D0A3h	Yes	No	2.5468
51	D0A4h	Yes	No	2.5625
52	D0A5h	Yes	No	2.5781
53	D0A6h	Yes	No	2.5937
54	D0A7h	Yes	No	2.609
55	D0A8h	Yes	No	2.625
56	D0A9h	Yes	No	2.6406
57	D0AAh	Yes	No	2.6562
58	D0ABh	Yes	No	2.6718
59	D0ACh	Yes	No	2.6875
60	D0B0h	Yes	No	2.75
61	D0B8h	Yes	No	2.875
62	D0C0h	Yes	No	3
63	D0C8h	Yes	No	3.125

### 7.5.10 Converter Protection and Response

The TPS53681 supports a variety of power supply protection features. The table below summarizes these protection features, and their related PMBus registers. See the following sections for more details.

**Table 36. TPS53681 Protection and Response**

	Threshold		Response	
	Command Name	Default Value	Command Name	Default Value
<b>Output Voltage</b>				
Over-Voltage Protection	<a href="#">VOUT_OV_FAULT_LIMIT</a>	1.520 V (Ch A) 1.520 V (Ch B)	<a href="#">VOUT_OV_FAULT_RESPONSE</a>	Shutdown, do not restart
Maximum Allowed Output Voltage	<a href="#">VOUT_MAX</a>	1.520 V (Ch A) 1.520 V (Ch B)	Refer to Register Description	
Under-Voltage Protection	<a href="#">VOUT_UV_FAULT_LIMIT</a>	0.000 V (Ch A) 0.000 V (Ch B)	<a href="#">VOUT_UV_FAULT_RESPONSE</a>	Shutdown, do not restart
Minimum Allowed Output Voltage	<a href="#">VOUT_MIN</a>	0.000 V (Ch A) 0.000 V (Ch B)	Refer to Register Description	
<b>Output Current</b>				
Over-Current Protection	<a href="#">IOUT_OC_FAULT_LIMIT</a> <a href="#">MFR_SPECIFIC_10</a>	39 A (Ch A) 39 A (Ch B)	<a href="#">IOUT_OC_FAULT_RESPONSE</a>	Shutdown, do not restart
Over-Current Warning	<a href="#">IOUT_OC_WARN_LIMIT</a>	26 A (Ch A) 26 A (Ch B)	N/A. Warning Only.	
<b>Input Voltage</b>				
Turn-On Threshold	<a href="#">VIN_ON</a>	6.25 V	N/A	
Over-Voltage Protection	<a href="#">VIN_OV_FAULT_LIMIT</a>	14.00 V	<a href="#">VIN_OV_FAULT_RESPONSE</a>	Continue Uninterrupted
Under-Voltage Protection	<a href="#">VIN_UV_FAULT_LIMIT</a>	5.50 V	<a href="#">VIN_UV_FAULT_RESPONSE</a>	Shutdown, do not restart
<b>Input Current</b>				
Over-Current Protection	<a href="#">IIN_OC_FAULT_LIMIT</a>	63.5 A	<a href="#">IIN_OC_FAULT_RESPONSE</a>	Shutdown, do not restart
Over-Current Warning	<a href="#">IIN_OC_WARN_LIMIT</a>	63.5 A	N/A. Warning Only	
<b>Temperature</b>				
Over-Temperature Protection	<a href="#">OT_FAULT_LIMIT</a>	135 °C (Ch A) 135 °C (Ch B)	<a href="#">OT_FAULT_RESPONSE</a>	Shutdown, do not restart
Over-Temperature Warning	<a href="#">OT_WARN_LIMIT</a>	105 °C (Ch A) 105 °C (Ch B)	N/A. Warning Only.	

### 7.5.11 Output Overvoltage Protection and Response

The output overvoltage thresholds track the configured maximum output voltage, VOUT\_MAX, with a fixed offset, and may be read back in VID format via the read-only VOUT\_OV\_FAULT\_LIMIT command. The converter response to an overvoltage fault is configured by the read-only VOUT\_OV\_FAULT\_RESPONSE command.

#### 7.5.11.1 (40h) VOUT\_OV\_FAULT\_LIMIT

The VOUT\_OV\_FAULT\_LIMIT is used to read back the value of the output voltage measured at the sense or output pins that causes an output overvoltage fault in VID format. VOUT\_OV\_FAULT\_LIMIT is a VID format command, and must be accessed through Read Word/Write Word transactions. VOUT\_OV\_FAULT\_LIMIT is a paged register. In order to access VOUT\_OV\_FAULT\_LIMIT for channel A, PAGE must be set to 00h. In order to access the VOUT\_OV\_FAULT\_LIMIT register for channel B, PAGE must be set to 01h. For simultaneous access of channels A and B, the PAGE command must be set to FFh.

15	14	13	12	11	10	9	8
R	R	R	R	R	R	R	R
0	0	0	0	0	0	0	0
7	6	5	4	3	2	1	0
R	R	R	R	R	R	R	R
VO_OVF_VID							

LEGEND: R/W = Read/Write; R = Read only

图 34. VOUT\_OV\_FAULT\_LIMIT

表 37. VOUT\_OV\_FAULT\_LIMIT Register Field Descriptions

Bit	Field	Type	Reset	Description
7:0	VO_OVF_VID	R	See below.	Read-only overvoltage fault limit, in VID format.

When the 5-mV DAC mode VID table is selected via MFR\_SPECIFIC\_13, the VOUT\_OV\_FAULT\_LIMIT register will be set to FFh. When the 10-mV DAC mode VID table is enabled, the VOUT\_OV\_FAULT\_LIMIT is determined according to the value of VOUT\_MAX, with a fixed offset applied.

#### 7.5.11.2 (41h) VOUT\_OV\_FAULT\_RESPONSE

The VOUT\_OV\_FAULT\_RESPONSE instructs the device on what action to take in response to an output overvoltage fault. The VOUT\_OV\_FAULT\_RESPONSE command must be accessed through Read Byte transactions. The VOUT\_OV\_FAULT\_RESPONSE command is shared between Channel A and Channel B. All transactions to this command will affect both channels regardless of the PAGE command.

Upon triggering the over-voltage fault, the controller is latched off, and the following actions are taken:

- Set the VOUT\_OV\_FAULT bit in the STATUS\_BYTE
- Set the VOUT bit in the STATUS\_WORD
- Set the VOUT\_OV\_FAULT bit in the STATUS\_VOUT register
- The device notifies the host (asserts PMB\_ALERT, if the corresponding mask bit in SMBALERT\_MASK is not set)

7	6	5	4	3	2	1	0
R	R	R	R	R	R	R	R
VO_OV_RESP							

LEGEND: R/W = Read/Write; R = Read only

图 35. VOUT\_OV\_FAULT\_RESPONSE

**表 38. VOUT\_OV\_FAULT\_RESPONSE Register Field Descriptions**

Bit	Field	Type	Reset	Description
7:0	VO_OV_RESP	R	80h	80h: Latch-off and do not restart. To clear a shutdown event due to a fault event, the user must toggle the AVR_EN/BEN pin and/or the ON bit in OPERATION, per the settings in ON_OFF_CONFIG, or power cycle the bias power to the V3P3 pin of the controller device.

**7.5.12 Maximum Allowed Output Voltage Setting**

The **VOUT\_MAX** command sets an upper limit on the output voltage that the unit may be commanded to, regardless of an other commands or combinations. The intent of this command is to provide a safeguard against a user accidentally setting the output voltage to a possibly destructive level.

**7.5.12.1 (24h) VOUT\_MAX**

The VOUT\_MAX command sets an upper limit on the output voltage that the unit may be commanded to, regardless of an other commands or combinations. The intent of this command is to provide a safeguard against a user accidentally setting the output voltage to a possibly destructive level. VOUT\_MAX is a VID format command, and must be accessed through Read Word/Write Word transactions. VOUT\_MAX is a paged register. In order to access VOUT\_MAX for channel A, PAGE must be set to 00h. In order to access the VOUT\_COMMAND register for channel B, PAGE must be set to 01h. For simultaneous access of channels A and B, the PAGE command must be set to FFh.

The device detects that an attempt has been made to program the output to a voltage greater than the value set by the VOUT\_MAX command. Attempts to program the output voltage greater than VOUT\_MAX can include VOUT\_COMMAND attempts, and margin events where the VOUT\_MARGIN\_HIGH/VOUT\_MARGIN\_LOW values exceed the value of VOUT\_MAX. These events will be treated as warning conditions and not as fault conditions. If an attempt is made to program the output voltage higher than the limit set by the VOUT\_MAX command, the device will respond as follows:

- The commanded output voltage will be clamped to VOUT\_MAX,
- The OTHER bit will be set in the STATUS\_BYTE,
- The VOUT bit will be set in the STATUS\_WORD,
- The VOUT\_MIN\_MAX warning bit will be set in the STATUS\_VOUT register, and
- The device notifies the host (asserts PMB\_ALERT, if the corresponding mask bit in SMBALERT\_MASK is not set).

This register should be programmed by the user depending upon the maximum output voltage the converter can support.

15	14	13	12	11	10	9	8
R	R	R	R	R	R	R	R
0	0	0	0	0	0	0	0
7	6	5	4	3	2	1	0
RW	RW	RW	RW	RW	RW	RW	RW
VOUT_MAX_VID							

LEGEND: R/W = Read/Write; R = Read only

**图 36. VOUT\_MAX**

**表 39. VOUT\_MAX Register Field Descriptions**

Bit	Field	Type	Reset	Description
7:0	VOUT_MAX_VID	RW	NVM	Used to set the maximum VOUT of the device in VID format.

### 7.5.13 Output Undervoltage Protection and Response

The output undervoltage protection threshold is configured based on commanded output voltage, VOUT\_COMMAND, including the shift due to the DC load line, and a fixed offset. The undervoltage threshold may be read back in VID format via the read-only VOUT\_UV\_FAULT\_LIMIT command. The converter response to an undervoltage fault is configured by the read-only VOUT\_UV\_FAULT\_RESPONSE command.

#### 7.5.13.1 (44h) VOUT\_UV\_FAULT\_LIMIT

The VOUT\_UV\_FAULT\_LIMIT is used to read back the value of the output voltage measured at the sense or output pins that causes an output undervoltage fault in VID format. VOUT\_UV\_FAULT\_LIMIT is a VID format command, and must be accessed through Read Word transactions. VOUT\_UV\_FAULT\_LIMIT is a paged register. In order to access VOUT\_UV\_FAULT\_LIMIT for channel A, PAGE must be set to 00h. In order to access the VOUT\_UV\_FAULT\_LIMIT register for channel B, PAGE must be set to 01h. For simultaneous access of channels A and B, the PAGE command must be set to FFh.

15	14	13	12	11	10	9	8
R	R	R	R	R	R	R	R
0	0	0	0	0	0	0	0
7	6	5	4	3	2	1	0
R	R	R	R	R	R	R	R
VO_UVF_VID							

LEGEND: R/W = Read/Write; R = Read only

图 37. VOUT\_UV\_FAULT\_LIMIT

表 40. VOUT\_UV\_FAULT\_LIMIT Register Field Descriptions

Bit	Field	Type	Reset	Description
7:0	VO_UVF_VID	R	See below.	Read-only undervoltage fault limit, in VID format.

#### 7.5.13.2 (45h) VOUT\_UV\_FAULT\_RESPONSE

The VOUT\_UV\_FAULT\_RESPONSE instructs the device on what action to take in response to an output undervoltage fault.

Upon triggering the undervoltage fault, the following actions are taken:

- Set the OTHER bit in the STATUS\_BYTE
- Set the VOUT bit in the STATUS\_WORD
- Set the VOUT\_UV\_FAULT bit in the STATUS\_VOUT register
- The device notifies the host (asserts PMB\_ALERT, if the corresponding mask bit in SMBALERT\_MASK is not set)

The VOUT\_UV\_FAULT\_RESPONSE command must be accessed through Read Byte/Write Byte transactions.

The VOUT\_UV\_FAULT\_RESPONSE command is shared between Channel A and Channel B. All transactions to this command will affect both channels regardless of the PAGE command.

7	6	5	4	3	2	1	0
RW	RW	RW	RW	RW	RW	RW	RW
VO_UV_RESP							

LEGEND: R/W = Read/Write; R = Read only

图 38. VOUT\_UV\_FAULT\_RESPONSE

**表 41. VOUT\_UV\_FAULT\_RESPONSE Register Field Descriptions**

Bit	Field	Type	Reset	Description
7:0	VO_UV_RESP	RW	NVM	00h: Ignore. The controller will set the appropriate status bits, and alert the host, but continue converting power. BAh: Shutdown and restart. The controller will shutdown the channel on which the fault occurred, and attempt to restart 20ms later. This will occur continuously until the condition causing the fault has disappeared, or the controller has been disabled. 80h: Latch-off and do not restart. To clear a shutdown event due to a fault event, the user must toggle the AVR_EN/BEN pin and/or the ON bit in OPERATION, per the settings in ON_OFF_CONFIG, or power cycle the bias power to the V3P3 pin of the controller device.

### 7.5.14 Minimum Allowed Output Voltage Setting

The **VOUT\_MIN** command sets a lower bound on the output voltage to which the unit can be commanded, regardless of any other commands or combinations. The intent of this command is to provide a safeguard against a user accidentally setting the output voltage to a possibly destructive level rather than to be the primary output under voltage protection.

#### 7.5.14.1 (2Bh) VOUT\_MIN

The VOUT\_MIN command sets a lower bound on the output voltage to which the unit can be commanded, regardless of any other commands or combinations. The intent of this command is to provide a safeguard against a user accidentally setting the output voltage to a possibly destructive level rather than to be the primary output under voltage protection. VOUT\_MIN is a VID format command, and must be accessed through Read Word/Write Word transactions. VOUT\_MIN is a paged register. In order to access VOUT\_MIN for channel A, PAGE must be set to 00h. In order to access the VOUT\_MIN register for channel B, PAGE must be set to 01h. For simultaneous access of channels A and B, the PAGE command must be set to FFh.

If an attempt is made to program the output voltage lower than the limit set by this command, the device will respond as follows:

- The commanded output voltage will be clamped to VOUT\_MIN
- The OTHER bit will be set in the STATUS\_BYTE
- The VOUT bit will be set in the STATUS\_WORD
- The VOUT\_MIN\_MAX Warning bit will be set in the STATUS\_VOUT register
- The device notifies the host (asserts PMB\_ALERT, if the corresponding mask bit in SMBALERT\_MASK is not set).

15	14	13	12	11	10	9	8
R	R	R	R	R	R	R	R
0	0	0	0	0	0	0	0
7	6	5	4	3	2	1	0
RW	RW	RW	RW	RW	RW	RW	RW
VOUT_MIN_VID							

LEGEND: R/W = Read/Write; R = Read only

**图 39. VOUT\_MIN**
**表 42. VOUT\_MIN Register Field Descriptions**

Bit	Field	Type	Reset	Description
7:0	VOUT_MIN_VID	RW	NVM	Used to set a lower bound for output voltage programming for the active PAGE, is set to in VID format.

## 7.5.15 Output Overcurrent Protection and Response

Overcurrent thresholds are configured using the `IOUT_OC_FAULT_LIMIT`. When the overcurrent fault threshold is reached, the converter will respond according to the settings in `IOUT_OC_FAULT_RESPONSE`. The `IOUT_OC_WARN_LIMIT` may also be used to configure an information-only overcurrent warning, which triggers prior to an overcurrent fault. Note, that the `MFR_SPECIFIC_00` command, not listed below, also contains settings for per-phase overcurrent limits. Refer to the device *Technical Reference Manual* for more information.

### 7.5.15.1 (46h) IOUT\_OC\_FAULT\_LIMIT

The `IOUT_OC_FAULT_LIMIT` command sets the value of the total output current, in amperes, that causes the over-current detector to indicate an over-current fault condition. The command has two data bytes and the data format is Linear as shown in the table below. The units are amperes. `IOUT_OC_FAULT_LIMIT` is a linear format command, and must be accessed through Read Word/Write Word transactions. `IOUT_OC_FAULT_LIMIT` is a paged register. In order to access `IOUT_OC_FAULT_LIMIT` command for channel A, `PAGE` must be set to 00h. In order to access `IOUT_OC_FAULT_LIMIT` register for channel B, `PAGE` must be set to 01h. For simultaneous access of channels A and B, the `PAGE` command must be set to FFh.

15	14	13	12	11	10	9	8
R	R	R	R	R	RW	RW	RW
IOOCF_EXP				IOOCF_MAN			
7	6	5	4	3	2	1	0
RW	RW	RW	RW	RW	RW	RW	RW
IOOCF_MAN							

LEGEND: R/W = Read/Write; R = Read only

图 40. IOUT\_OC\_FAULT\_LIMIT

表 43. IOUT\_OC\_FAULT\_LIMIT Register Field Descriptions

Bit	Field	Type	Reset	Description
15:11	IOOCF_EXP	R	00000b	Linear two's complement exponent, 0. LSB = 1.0 A
10:0	IOOCF_MAN	RW	See below.	Linear two's complement mantissa

At power-on, or after a `RESTORE_DEFAULT_ALL` operation, the `IOUT_OC_FAULT_LIMIT` command will be loaded with the value of `IOUT_MAX` × 1.50. The `IOUT_MAX` bits for each channel are stored in `MFR_SPECIFIC_10` (`PAGE` 0 for channel A, `PAGE` 1 for channel B). `IOUT_OC_FAULT_LIMIT` may be changed during operation, but returns to this value on reset.

### 7.5.15.2 (4Ah) IOUT\_OC\_WARN\_LIMIT

The `IOUT_OC_WARN_LIMIT` command sets the value of the output current, in amperes, that causes the over-current detector to indicate an over-current warning condition. `IOUT_OC_WARN_LIMIT` is a linear format command, and must be accessed through Read Word/Write Word transactions. `IOUT_OC_WARN_LIMIT` is a paged register. In order to access `IOUT_OC_WARN_LIMIT` command for channel A, `PAGE` must be set to 00h. In order to access `IOUT_OC_WARN_LIMIT` register for channel B, `PAGE` must be set to 01h. For simultaneous access of channels A and B, the `PAGE` command must be set to FFh.

#### 注

`IOUT_OC_WARN_LIMIT` maximum default value is 255A. In case, Application maximum load current is greater than 255A, `IOUT_OC_WARN_LIMIT` needs to change as max load current value each time after power-on or `RESTORE_DEFAULT_ALL` operation.

Upon triggering the overcurrent warning, the following actions are taken:

- Set the `OTHER` bit in the `STATUS_BYTE`
- Set the `IOUT` bit in the `STATUS_WORD`
- Set the `IOUT` Over current Warning bit in the `STATUS_IOUT` register
- The device notifies the host (asserts `PMB_ALERT`, if the corresponding mask bit in `SMBALERT_MASK` is not

set)

15	14	13	12	11	10	9	8
R	R	R	R	R	RW	RW	RW
IOOCW_EXP					IOOCW_MAN		
7	6	5	4	3	2	1	0
RW	RW	RW	RW	RW	RW	RW	RW
IOOCW_MAN							

LEGEND: R/W = Read/Write; R = Read only

**图 41. IOUT\_OC\_WARN\_LIMIT**
**表 44. IOUT\_OC\_WARN\_LIMIT Register Field Descriptions**

Bit	Field	Type	Reset	Description
15:11	IOOCW_EXP	R	00000b	Linear two's complement exponent, 0. LSB = 1.0 A
10:0	IOOCW_MAN	RW	See below.	Linear two's complement mantissa.

At power-on, or after a RESTORE\_DEFAULT\_ALL operation, the IOUT\_OC\_WARN\_LIMIT command will be loaded with the value of IOUT\_MAX. The IOUT\_MAX bits for each channel are stored in [MFR\\_SPECIFIC\\_10](#) (PAGE 0 for channel A, PAGE 1 for channel B). IOUT\_OC\_WARN\_LIMIT may be changed during operation, but will return to this value on reset.

### 7.5.15.3 (47h) IOUT\_OC\_FAULT\_RESPONSE

The IOUT\_OC\_FAULT\_RESPONSE instructs the device on what action to take in response to an output over-current fault. The IOUT\_OC\_FAULT\_RESPONSE command must be accessed through Read Byte/Write Byte transactions. The IOUT\_OC\_FAULT\_RESPONSE command is shared between Channel A and Channel B. All transactions to this command will affect both channels regardless of the PAGE command.

Upon triggering the over-current fault, the controller is latched off, and the following actions are taken:

- Set the IOUT\_OC\_FAULT bit in the STATUS\_BYTE
- Set the IOUT bit in the STATUS\_WORD
- Set the IOUT\_OC\_FAULT bit in the STATUS\_IOUT register
- The device notifies the host (asserts PMB\_ALERT, if the corresponding mask bit in SMBALERT\_MASK is not set)

7	6	5	4	3	2	1	0
RW	RW	RW	RW	RW	RW	RW	RW
IO_OC_RESP							

LEGEND: R/W = Read/Write; R = Read only

**图 42. IOUT\_OC\_FAULT\_RESPONSE**
**表 45. IOUT\_OC\_FAULT\_RESPONSE Register Field Descriptions**

Bit	Field	Type	Reset	Description
7:0	IO_OC_RESP	RW	NVM	<p>C0h: Latch-off and do not restart. To clear a shutdown event due to a fault event, the user must toggle the AVR_EN/BEN pin and/or the ON bit in OPERATION, per the settings in ON_OFF_CONFIG, or power cycle the bias power to the V3P3 pin of the controller device.</p> <p>FAh: Shutdown and restart. The controller will shutdown the channel on which the fault occurred, and attempt to restart 20ms later. This will occur continuously until the condition causing the fault has disappeared, or the controller has been disabled.</p>

### 7.5.16 Input Under-Voltage Lockout (UVLO)

The TPS53681 may not start converting power, until the power stage input voltage reaches the level specified by [VIN\\_ON](#).

#### 7.5.16.1 (35h) VIN\_ON

The VIN\_ON command sets the value of the input voltage, in Volts, at which the unit should start power conversion. This command has two data bytes encoded in linear data format, and must be accessed through Read Word/Write Word transactions. The VIN\_ON command is shared between Channel A and Channel B. All transactions to this command will affect both channels regardless of the PAGE command. The supported range for VIN\_ON is from 4.0 V volts to 11.25 Volts.

15	14	13	12	11	10	9	8
R	R	R	R	R	RW	RW	RW
VINON_EXP					VINON_MAN		
7	6	5	4	3	2	1	0
RW	RW	RW	RW	RW	RW	RW	RW
VINON_MAN							

LEGEND: R/W = Read/Write; R = Read only

**图 43. VIN\_ON**

**表 46. VIN\_ON Register Field Descriptions**

Bit	Field	Type	Reset	Description
15:11	VINON_EXP	R	11110b	Linear two's complement exponent, –2. LSB = 0.25 V
10:0	VINON_MAN	RW	NVM	Linear two's complement mantissa. See the table of acceptable values below.

**表 47. Acceptable Values of VIN\_ON**

VIN_ON (hex)	Turn-On Voltage (V)
F010h	4.0
F015h	5.25
F019h	6.25
F01Dh	7.25
F021h	8.25
F025h	9.25
F029h	10.25
F02Dh	11.25

### 7.5.17 Input Over-Voltage Protection and Response

The TPS53681 provides protection from input transients via the [VIN\\_OV\\_FAULT\\_LIMIT](#) and [VIN\\_OV\\_FAULT\\_RESPONSE](#) commands.

#### 7.5.17.1 (55h) VIN\_OV\_FAULT\_LIMIT

The VIN\_OV\_FAULT\_LIMIT command sets the value of the input voltage that causes an input overvoltage fault. VIN\_OV\_FAULT\_LIMIT is a linear format command, and must be accessed through Read Word/Write Word transactions. The VIN\_OV\_FAULT\_LIMIT command is shared between Channel A and Channel B. All transactions to this command will affect both channels regardless of the PAGE command.

15	14	13	12	11	10	9	8
R	R	R	R	R	RW	RW	RW
VIN_OVF_EXP					VIN_OVF_MAN		
7	6	5	4	3	2	1	0
RW	RW	RW	RW	RW	RW	RW	RW
VIN_OVF_MAN							

LEGEND: R/W = Read/Write; R = Read only

**图 44. VIN\_OV\_FAULT\_LIMIT**
**表 48. VIN\_OV\_FAULT\_LIMIT Register Field Descriptions**

Bit	Field	Type	Reset	Description
15:11	VIN_OVF_EXP	R	00000b	Linear two's complement exponent, 0. LSB = 1 V
10:0	VIN_OVF_MAN	RW	NVM	Linear two's complement mantissa. Valid values of the mantissa range from 0d to 31d.

### 7.5.17.2 (56h) VIN\_OV\_FAULT\_RESPONSE

The VIN\_OV\_FAULT\_RESPONSE command instructs the device on what action to take in response to an input overvoltage fault. The VIN\_OV\_FAULT\_RESPONSE command must be accessed through Read Byte transactions. The VIN\_OV\_FAULT\_RESPONSE command is shared between Channel A and Channel B. All transactions to this command will affect both channels regardless of the PAGE command.

In response to the VIN\_OV\_LIMIT being exceeded, the device will:

- Set the OTHER bit in the STATUS\_BYTE
- Set the INPUT bit in the upper byte of the STATUS\_WORD
- Sets the VIN\_OV\_FAULT bit in the STATUS\_INPUT register
- Notify the host (assert the PMB\_ALERT signal, if the corresponding mask bit in SMBALERT\_MASK is not set)

7	6	5	4	3	2	1	0
R	R	R	R	R	R	R	R
VI_OVF_RESP							

LEGEND: R/W = Read/Write; R = Read only

**图 45. VIN\_OV\_FAULT\_RESPONSE**
**表 49. VIN\_OV\_FAULT\_RESPONSE Register Field Descriptions**

Bit	Field	Type	Reset	Description
7:0	VI_OVF_RESP	R	00h	00h: Ignore. The controller will set the appropriate status bits, and alert the host, but continue converting power.

### 7.5.18 Input Undervoltage Protection and Response

The TPS53681 provides protection from input transients via the [VIN\\_UV\\_FAULT\\_LIMIT](#) and [VIN\\_UV\\_FAULT\\_RESPONSE](#) commands.

#### 7.5.18.1 (59h) VIN\_UV\_FAULT\_LIMIT

The VIN\_UV\_FAULT\_LIMIT command sets the value of the input voltage that causes an Input Under voltage Fault. This fault is masked until the input exceeds the value set by the VIN\_ON command for the first time, and the unit has been enabled. VIN\_UV\_FAULT\_LIMIT is a linear format command, and must be accessed through Read Word/Write Word transactions. The VIN\_UV\_FAULT\_LIMIT command is shared between Channel A and Channel B. All transactions to this command will affect both channels regardless of the PAGE command.

15	14	13	12	11	10	9	8
RW	RW	RW	RW	RW	RW	RW	RW
VIN_UVF_EXP				VIN_UVF_MAN			
7	6	5	4	3	2	1	0
RW	RW	RW	RW	RW	RW	RW	RW
VIN_UVF_MAN							

LEGEND: R/W = Read/Write; R = Read only

图 46. VIN\_UV\_FAULT\_LIMIT

表 50. VIN\_UV\_FAULT\_LIMIT Register Field Descriptions

Bit	Field	Type	Reset	Description
15:11	VIN_UVF_EXP	RW	NVM	Linear two's complement exponent. See the table of acceptable values below.
10:0	VIN_UVF_MAN	RW	NVM	Linear two's complement mantissa. See the table of acceptable values below.

表 51. Acceptable Values of VIN\_UV\_FAULT\_LIMIT

VIN_UV_FAULT_LIMIT (hex)	VIN UVF Limit (V)
F011h	4.25
F80Bh	5.5
F80Dh	6.5
F80Fh	7.5
F811h	8.5
F813h	9.5
F815h	10.5
F817h	11.5

7.5.18.2 (5Ah) VIN\_UV\_FAULT\_RESPONSE

The VIN\_UV\_FAULT\_RESPONSE command instructs the device on what action to take in response to an input overvoltage fault. The VIN\_UV\_FAULT\_RESPONSE command must be accessed through Read Byte transactions. The VIN\_UV\_FAULT\_RESPONSE command is shared between Channel A and Channel B. All transactions to this command will affect both channels regardless of the PAGE command.

In response to the VIN\_UV\_LIMIT being exceeded, the device will:

- Set the OTHER bit in the STATUS\_BYTE
- Set the INPUT bit in the upper byte of the STATUS\_WORD
- Set the VIN\_UV\_FAULT bit in the STATUS\_INPUT register
- The device notifies the host (asserts PMB\_ALERT, if the corresponding mask bit in SMBALERT\_MASK is not set)

7	6	5	4	3	2	1	0
R	R	R	R	R	R	R	R
VI_UVF_RESP							

LEGEND: R/W = Read/Write; R = Read only

图 47. VIN\_UV\_FAULT\_RESPONSE

表 52. VIN\_UV\_FAULT\_RESPONSE Register Field Descriptions

Bit	Field	Type	Reset	Description
7:0	VI_UVF_RESP	R	C0h	C0h: Shutdown and restart when the fault condition is no longer present.

### 7.5.19 Input Overcurrent Protection and Response

Input overcurrent protection is configured via the `IIN_OC_FAULT_LIMIT`, `IIN_OC_WARN_LIMIT` and `IIN_OC_FAULT_RESPONSE` commands.

#### 7.5.19.1 (5Bh) IIN\_OC\_FAULT\_LIMIT

The `IIN_OC_FAULT_LIMIT` command sets the value of the input current, in amperes, that causes the input over current fault condition. `IIN_OC_FAULT_LIMIT` is a linear format command, and must be accessed through Read Word/Write Word transactions. The `IIN_OC_FAULT_LIMIT` command is shared between Channel A and Channel B. All transactions to this command will affect both channels regardless of the `PAGE` command.

15	14	13	12	11	10	9	8
R	R	R	R	R	RW	RW	RW
IIN_OCF_EXP					IIN_OCF_MAN		
7	6	5	4	3	2	1	0
RW	RW	RW	RW	RW	RW	RW	RW
IIN_OCF_MAN							

LEGEND: R/W = Read/Write; R = Read only

图 48. IIN\_OC\_FAULT\_LIMIT

表 53. IIN\_OC\_FAULT\_LIMIT Register Field Descriptions

Bit	Field	Type	Reset	Description
15:11	IIN_OCF_EXP	R	11111b	Linear two's complement format exponent, –1. LSB = 0.5 A.
10:0	IIN_OCF_MAN	RW	See below.	Linear two's complement format mantissa. Acceptable values range from 0d (0 A) to 127d (63.5 A).

During operation, the `IIN_OC_FAULT_LIMIT` may be changed to any valid value, as specified above. The `IIN_OC_FAULT_LIMIT` command has only limited NVM backup. The table below summarizes the values that `IIN_OC_FAULT_LIMIT` may be restored to following a reset, or `RESTORE_DEFAULT_ALL` operation.

表 54. IIN\_OC\_FAULT\_LIMIT reset values

Hex Value	IIN_OC_FAULT_LIMIT during NVM store operation	IIN_OC_FAULT_LIMIT following Reset/Restore Operation
F810h	8 A	8 A
F820h	16 A	16 A
F830h	24 A	24 A
F840h	32 A	32 A
F850h	40 A	40 A
F860h	48 A	48 A
F870h	56 A	56 A
F87Fh	63.5 A	63.5 A
Any other valid data	Any other valid data	63.5 A

#### 7.5.19.2 (5Dh) IIN\_OC\_WARN\_LIMIT

The `IIN_OC_WARN_LIMIT` command sets the value of the input current, in amperes, that causes the input overcurrent warning condition. The `IIN_OC_WARN_LIMIT` command must be accessed through Read Word/Write Word transactions. The `IIN_OC_WARN_LIMIT` command is shared between Channel A and Channel B. All transactions to this command will affect both channels regardless of the `PAGE` command.

Upon triggering the over-current warning, the following actions are taken:

- Set the `OTHER` bit in the `STATUS_BYTE`
- Set the `INPUT` bit in the `STATUS_WORD`
- Set the `IIN Over-current Warning` bit in the `STATUS_INPUT` register
- The device notifies the host (asserts `PMB_ALERT`, if the corresponding mask bit in `SMBALERT_MASK` is not set)

15	14	13	12	11	10	9	8
R	R	R	R	R	R	R	R
IIN_OCW_EXP				IIN_OCW_MAN			
7	6	5	4	3	2	1	0
R	RW	RW	RW	RW	RW	RW	RW
IIN_OCW_MAN							

LEGEND: R/W = Read/Write; R = Read only

**图 49. IIN\_OC\_WARN\_LIMIT**

**表 55. IIN\_OC\_FAULT\_LIMIT Register Field Descriptions**

Bit	Field	Type	Reset	Description
15:11	IIN_OCW_EXP	R	11111b	Linear two's complement format exponent, -1. LSB = 0.5 A.
10:0	IIN_OCW_MAN	RW	See below.	Linear two's complement format mantissa. Acceptable values range from 0d (0 A) to 127d (63.5 A).

During operation, the IIN\_OC\_FAULT\_LIMIT may be changed to any valid value, as specified above. The IIN\_OC\_FAULT\_LIMIT command has only limited NVM backup. The table below summarizes the values that IIN\_OC\_FAULT\_LIMIT may be restored to following a reset, or RESTORE\_DEFAULT\_ALL operation.

**表 56. IIN\_OC\_WARN\_LIMIT reset values**

Hex Value	IIN_OC_WARN_LIMIT during NVM store operation	IIN_OC_WARN_LIMIT following Reset/Restore Operation
F810h	8 A	8 A
F820h	16 A	16 A
F830h	24 A	24 A
F840h	32 A	32 A
F850h	40 A	40 A
F860h	48 A	48 A
F870h	56 A	56 A
F87Fh	63.5 A	63.5 A
Any other valid data	Any other valid data	63.5 A

**7.5.19.3 (5Ch) IIN\_OC\_FAULT\_RESPONSE**

The IIN\_OC\_FAULT\_RESPONSE command instructs the device on what action to take in response to an input over-current fault. IIN\_OC\_FAULT\_RESPONSE command must be accessed through Read Byte transactions. The IIN\_OC\_FAULT\_RESPONSE command is shared between Channel A and Channel B. All transactions to this command will affect both channels regardless of the PAGE command.

Upon triggering the input over-current fault, the controller is latched off, and the following actions are taken:

- Set the OTHER bit in the STATUS\_BYTE
- Set the INPUT bit in the STATUS\_WORD
- Set the IIN\_OC\_FAULT bit in the STATUS\_INPUT register
- The device notifies the host (asserts PMB\_ALERT and VR\_FAULT, if the corresponding mask bit in SMBALERT\_MASK is not set)

7	6	5	4	3	2	1	0
R	R	R	R	R	R	R	R
IIN_OC_RESP							

LEGEND: R/W = Read/Write; R = Read only

**图 50. IIN\_OC\_FAULT\_RESPONSE**
**表 57. IIN\_OC\_FAULT\_LIMIT Register Field Descriptions**

Bit	Field	Type	Reset	Description
7:0	IIN_OC_RESP	R	C0h	C0h: Latch-off and do not restart. To clear a shutdown event due to a fault event, the user must toggle the AVR_EN/BEN pin and/or the ON bit in OPERATION, per the settings in ON_OFF_CONFIG, or power cycle the bias power to the V3P3 pin of the controller device.

**7.5.20 Over-Temperature Protection and Response**

Overtemperature protection is configured via the [OT\\_FAULT\\_LIMIT](#), [OT\\_WARN\\_LIMIT](#) and [OT\\_FAULT\\_RESPONSE](#) commands.

**7.5.20.1 (4Fh) OT\_FAULT\_LIMIT**

The OT\_FAULT\_LIMIT command sets the value of the temperature limit, in degrees Celsius, that causes an overtemperature fault condition when the sensed temperature from the external sensor exceeds this limit. The default value is selected in MFR\_SPECIFIC\_13, using the OTF\_DFLT bit. Refer to the device *Technical Reference Manual* for more information. OT\_FAULT\_LIMIT is a linear format command, and must be accessed through Read Word/Write Word transactions. OT\_FAULT\_LIMIT is a paged register. In order to access OT\_FAULT\_LIMIT command for channel A, PAGE must be set to 00h. In order to access OT\_FAULT\_LIMIT register for channel B, PAGE must be set to 01h. For simultaneous access of channels A and B, the PAGE command must be set to FFh.

15	14	13	12	11	10	9	8
R	R	R	R	R	RW	RW	RW
OTF_EXP					OTF_MAN		
7	6	5	4	3	2	1	0
RW	RW	RW	RW	RW	RW	RW	RW
OTF_MAN							

LEGEND: R/W = Read/Write; R = Read only

**图 51. OT\_FAULT\_LIMIT**
**表 58. OT\_FAULT\_LIMIT Register Field Descriptions**

Bit	Field	Type	Reset	Description
15:11	OTF_EXP	R	00000b	Linear two's complement exponent, 0. LSB = 1 °C
10:0	OTF_MAN	RW	NVM	Linear two's complement mantissa. The default OT_FAULT_LIMIT is set by the OTF_DFLT bit in MFR_SPECIFIC_13.

**7.5.20.2 (51h) OT\_WARN\_LIMIT**

The OT\_WARN\_LIMIT command sets the temperature, in degrees Celsius, of the unit at which it should indicate an Over-temperature Warning event. OT\_WARN\_LIMIT is a linear format command, and must be accessed through Read Word/Write Word transactions. OT\_WARN\_LIMIT is a paged register. In order to access OT\_WARN\_LIMIT command for channel A, PAGE must be set to 00h. In order to access OT\_WARN\_LIMIT register for channel B, PAGE must be set to 01h. For simultaneous access of channels A and B, the PAGE command must be set to FFh.

In response to the OT\_WARN\_LIMIT being exceeded, the device will:

- Set the TEMPERATURE bit in the STATUS\_BYTE
- Set the Over-temperature Warning bit in the STATUS\_TEMPERATURE register
- Notify the host (asserts PMB\_ALERT, if the corresponding mask bit in SMBALERT\_MASK is not set)

15	14	13	12	11	10	9	8
R	R	R	R	R	RW	RW	RW
OTW_EXP				OTW_MAN			
7	6	5	4	3	2	1	0
RW	RW	RW	RW	RW	RW	RW	RW
OTW_MAN							

LEGEND: R/W = Read/Write; R = Read only

图 52. OT\_WARN\_LIMIT

表 59. OT\_WARN\_LIMIT Register Field Descriptions

Bit	Field	Type	Reset	Description
15:11	OTF_EXP	R	00000b	Linear two's complement exponent, 0. LSB = 1 °C
10:0	OTF_MAN	RW	105d	Linear two's complement mantissa. Default = 105 °C

7.5.20.3 (50h) OT\_FAULT\_RESPONSE

The OT\_FAULT\_RESPONSE instructs the device on what action to take in response to an output over-temperature fault. The OT\_FAULT\_RESPONSE command must be accessed through Read Byte/Write Byte transactions. The OT\_FAULT\_RESPONSE command is shared between Channel A and Channel B. All transactions to this command will affect both channels regardless of the PAGE command.

Upon triggering the over-temperature fault, the controller is latched off, and the following actions are taken:

- Set the TEMPERATURE bit in the STATUS\_BYTE
- Set the OT\_FAULT bit in the STATUS\_TEMPERATURE register
- The device notifies the host (asserts PMB\_ALERT, if the corresponding mask bit in SMBALERT\_MASK is not set).

7	6	5	4	3	2	1	0
RW	RW	RW	RW	RW	RW	RW	RW
OTF_RESP							

LEGEND: R/W = Read/Write; R = Read only

图 53. OT\_FAULT\_RESPONSE

表 60. OT\_FAULT\_RESPONSE Register Field Descriptions

Bit	Field	Type	Reset	Description
7:0	OTF_RESP	RW	NVM	80h: Latch-off and do not restart. To clear a shutdown event due to a fault event, the user must toggle the AVR_EN/BEN pin and/or the ON bit in OPERATION, per the settings in ON_OFF_CONFIG, or power cycle the bias power to the V3P3 pin of the controller device. C0h: Shutdown and restart when the fault condition is no longer present.

### 7.5.21 Dynamic Phase Shedding (DPS)

The dynamic phase shedding (DPS) feature allows the TPS53681 to dynamically select the number of operational phases for each channel, based on the total output current. This increases the total converter efficiency by reducing unnecessary switching losses when the output current is low enough to be supported by a fewer number of phases, than are available in hardware. The [MFR\\_SPECIFIC\\_14](#) and [MFR\\_SPECIFIC\\_15](#) commands may be used to configure dynamic phase shedding behavior and thresholds.

The DPS\_EN bit in [MFR\\_SPECIFIC\\_14](#) may be used to enable or disable dynamic phase shedding. Un-setting (writing to 0b) this bit forces each channel to use the maximum number of available phases, regardless of the output current.

The phase add/drop thresholds, at which phases are added or dropped are configured based on the peak efficiency point per phase. For a given switching frequency/duty cycle, the efficiency of an individual power stage has a "peak" point, at which switching losses become less significant and conduction losses begin to dominate. For a multiphase converter, the optimum efficiency is achieved when all of the power stages operate as close as possible to their peak efficiency point. For example, consider a 4-phase design, with power stages that have a peak efficiency point of 12 A per phase. When the total output current is 25 A, if all four phases were active, each phase would be supplying 6.25 A, and hence would be operating far away from their peak efficiency point. With only two phases active, however, each phase supplies 12.5A, meaning that each power stage is operating close to its peak efficiency point, therefore the total converter efficiency is higher overall.

In order to maintain regulation during severe load transient events, phases may be added immediately whenever the total peak current reaches phase addition thresholds. To prevent chattering, phases are dropped when the total average current falls below phase drop thresholds, after a delay of 85  $\mu$ s typically. Phases are always added/dropped, in numerical order. For example, phase 3 is added after phase 2, and dropped after phase 4.

The DPS\_COURSE\_TH bits in [MFR\\_SPECIFIC\\_15](#) select the peak efficiency point per phase. Refer to the power stage datasheet to determine the peak efficiency point per phase.

Phase adding thresholds are configured based on the peak efficiency point per phase. Each phase transition has a configurable threshold of 6 A to 12 A above the peak efficiency point. For example, the threshold at which the converter transitions from 2 phases to 3 phases is determined by the DPS\_2TO3\_FINE\_ADD bits in [MFR\\_SPECIFIC\\_15](#). When 8 A is selected, the total peak current which causes the third phase to be added is  $2 \times I_{\text{EFF(PEAK)}} + 8$  A. See the register descriptions below for more detailed information.

Likewise, phase drop thresholds are configured based on the peak efficiency point per phase. Each phase transition has a configurable threshold of 2A below to 4 A above the peak efficiency point. For example, the threshold at which the converter transitions from 3 phases to 2 phases is determined by the DPS\_3TO2\_FINE\_DROP bits in [MFR\\_SPECIFIC\\_14](#). When 0 A is selected, the total average current which causes the third phase to be dropped is  $2 \times I_{\text{EFF(PEAK)}}$ . See the register descriptions below for more detailed information.

### 7.5.21.1 (DEh) MFR\_SPECIFIC\_14

The MFR\_SPECIFIC\_14 command is used to configure dynamic phase shedding, and compensation ramp amplitude, and dynamic ramp amplitude during USR, and different power states. The MFR\_SPECIFIC\_14 command must be accessed through Write Word/Read Word transactions.

MFR\_SPECIFIC\_14 is a paged register. In order to access MFR\_SPECIFIC\_14 command for channel A, PAGE must be set to 00h. In order to access the MFR\_SPECIFIC\_14 register for channel B, PAGE must be set to 01h.

15		14		13		12		11		10		9		8	
RW		RW		RW		RW		RW		RW		RW		RW	
DPS_6TO5_FINE_DROP (PAGE 0 only)				DPS_5TO4_FINE_DROP (PAGE 0 only)				DPS_4TO3_FINE_DROP (PAGE 0 only)				DPS_3TO2_FINE_DROP			
7		6		5		4		3		2		1		0	
RW		RW		RW		RW		RW		RW		RW		RW	
DPS_EN		DYN_RAMP_USR				DYN_RAMP_2 PH		DYN_RAMP_1 PH		RAMP					

LEGEND: R/W = Read/Write; R = Read only

图 54. MFR\_SPECIFIC\_14

表 61. MFR\_SPECIFIC\_14 Register Field Descriptions

Bit	Field	Type	Reset	Description
15:14	DPS_6TO5_FINE_DROP (PAGE 0 only)	RW	NVM	Dynamic phase drop threshold, fine adjustment, 6 phases to 5 phases. Set as an offset from peak efficiency point per phase in Amperes. Phases drop when average phase current reaches the stated threshold. $I_{EFF(PEAK)}$ refers to the value selected by DPS_COURSE_TH in <a href="#">MFR_SPECIFIC_15</a> . 00b: Threshold = $5 \times I_{EFF(PEAK)} - 2 A$ 01b: Threshold = $5 \times I_{EFF(PEAK)}$ 10b: Threshold = $5 \times I_{EFF(PEAK)} + 2 A$ 11b: Threshold = $5 \times I_{EFF(PEAK)} + 4 A$
13:12	DPS_5TO4_FINE_DROP (PAGE 0 only)	RW	NVM	Dynamic phase drop threshold, fine adjustment, 5 phases to 4 phases. Set as an offset from peak efficiency point per phase in Amperes. Phases drop when average phase current reaches the stated threshold. $I_{EFF(PEAK)}$ refers to the value selected by DPS_COURSE_TH in <a href="#">MFR_SPECIFIC_15</a> . 00b: Threshold = $4 \times I_{EFF(PEAK)} - 2 A$ 01b: Threshold = $4 \times I_{EFF(PEAK)}$ 10b: Threshold = $4 \times I_{EFF(PEAK)} + 2 A$ 11b: Threshold = $4 \times I_{EFF(PEAK)} + 4 A$
11:10	DPS_4TO3_FINE_DROP (PAGE 0 only)	RW	NVM	Dynamic phase drop threshold, fine adjustment, 4 phases to 3 phases. Set as an offset from peak efficiency point per phase in Amperes. Phases drop when average phase current reaches the stated threshold. $I_{EFF(PEAK)}$ refers to the value selected by DPS_COURSE_TH in <a href="#">MFR_SPECIFIC_15</a> . 00b: Threshold = $3 \times I_{EFF(PEAK)} - 2 A$ 01b: Threshold = $3 \times I_{EFF(PEAK)}$ 10b: Threshold = $3 \times I_{EFF(PEAK)} + 2 A$ 11b: Threshold = $3 \times I_{EFF(PEAK)} + 4 A$
9:8	DPS_3TO2_FINE_DROP	RW	NVM	Dynamic phase drop threshold, fine adjustment, 3 phases to 2 phases. Set as an offset from peak efficiency point per phase in Amperes. Phases drop when average phase current reaches the stated threshold. $I_{EFF(PEAK)}$ refers to the value selected by DPS_COURSE_TH in <a href="#">MFR_SPECIFIC_15</a> . 00b: Threshold = $2 \times I_{EFF(PEAK)} - 2 A$ 01b: Threshold = $2 \times I_{EFF(PEAK)}$ 10b: Threshold = $2 \times I_{EFF(PEAK)} + 2 A$ 11b: Threshold = $2 \times I_{EFF(PEAK)} + 4 A$

**表 61. MFR\_SPECIFIC\_14 Register Field Descriptions (接下页)**

Bit	Field	Type	Reset	Description
7	DPS_EN	RW	NVM	Enable or Disable Dynamic Phase Shedding 0b: Disable dynamic phase shedding 1b: Enable dynamic phase shedding
6:5	DYN_RAMP_USR	RW	NVM	Dynamic ramp amplitude setting during USR operation. Only applies to USR Level 1. 00b: Equal to the settings in the RAMP bits 01b: 40 mV 10b: 80 mV 11b: 120 mV
4	DYN_RAMP_2PH	RW	NVM	Dynamic ramp amplitude setting during 2 phase operation. 0b: Equal to the settings in the RAMP bits 1b: 120 mV
3	DYN_RAMP_1PH	RW	NVM	Dynamic ramp amplitude setting during 1 phase operation. 0b: Equal to the settings in the RAMP bits 1b: 80 mV
2:0	RAMP	RW	NVM	Ramp amplitude settings. See 表 62.

**表 62. Ramp Amplitude Settings**

RAMP (binary)	Ramp Amplitude Setting (mV)
000b	40
001b	80
010b	120
011b	160
100b	200
101b	240
110b	280
111b	320

**7.5.21.2 (DFh) MFR\_SPECIFIC\_15**

The MFR\_SPECIFIC\_15 command is used to configure dynamic phase shedding. The MFR\_SPECIFIC\_15 command must be accessed through Write Word/Read Word transactions.

MFR\_SPECIFIC\_15 is a paged register. In order to access MFR\_SPECIFIC\_15 command for channel A, PAGE must be set to 00h. In order to access the MFR\_SPECIFIC\_15 register for channel B, PAGE must be set to 01h.

15	14	13	12	11	10	9	8
RW	RW	RW	RW	RW	RW	RW	RW
DPS_DCM	DPS_2TO1_FINE_DROP		DPS_5TO6_FINE_ADD (PAGE 0 only)		DPS_4TO5_FINE_ADD (PAGE 0 only)		DPS_3TO4_FINE_ADD (PAGE 0 only)
7	6	5	4	3	2	1	0
RW	RW	RW	RW	RW	RW	RW	RW
DPS_3TO4_FINE_ADD (PAGE 0 only)	DPS_2TO3_FINE_ADD		DPS_1TO2_FINE_ADD		2TO1_PH_EN	DPS_COURSE_TH	

LEGEND: R/W = Read/Write; R = Read only

**图 55. MFR\_SPECIFIC\_15**

**表 63. MFR\_SPECIFIC\_15 Register Field Descriptions**

Bit	Field	Type	Reset	Description
15	DPS_DCM	RW	NVM	Enable DCM mode during 1 phase operation, when higher order phases are dropped due to dynamic phase shedding. 0b: Disable DCM operation during 1 phase operation 1b: Enable DCM operation during 1 phase operation
14:13	DPS_2TO1_FINE_DROP	RW	NVM	Dynamic phase drop threshold, fine adjustment, 2 phases to 1phase. Set as an offset from peak efficiency point per phase in Amperes. Phases drop when average phase current reaches the stated threshold. $I_{EFF(PEAK)}$ refers to the value selected by DPS_COURSE_TH below. 00b: Threshold = $1 \times I_{EFF(PEAK)} - 2 \text{ A}$ 01b: Threshold = $1 \times I_{EFF(PEAK)}$ 10b: Threshold = $1 \times I_{EFF(PEAK)} + 2 \text{ A}$ 11b: Threshold = $1 \times I_{EFF(PEAK)} + 4 \text{ A}$
12:11	DPS_5TO6_FINE_ADD (PAGE 0 only)	RW	NVM	Dynamic phase add threshold, fine adjustment, 5 phases to 6 phases. Set as an offset from peak efficiency point per phase in Amperes. Phases add when peak phase current reaches the stated threshold. $I_{EFF(PEAK)}$ refers to the value selected by DPS_COURSE_TH below. 00b: Threshold = $5 \times I_{EFF(PEAK)} + 6 \text{ A}$ 01b: Threshold = $5 \times I_{EFF(PEAK)} + 8 \text{ A}$ 10b: Threshold = $5 \times I_{EFF(PEAK)} + 10 \text{ A}$ 11b: Threshold = $5 \times I_{EFF(PEAK)} + 12 \text{ A}$
10:9	DPS_4TO5_FINE_ADD (PAGE 0 only)	RW	NVM	Dynamic phase add threshold, fine adjustment, 4 phases to 5 phases. Set as an offset from peak efficiency point per phase in Amperes. Phases add when peak phase current reaches the stated threshold. $I_{EFF(PEAK)}$ refers to the value selected by DPS_COURSE_TH below 00b: Threshold = $4 \times I_{EFF(PEAK)} + 6 \text{ A}$ 01b: Threshold = $4 \times I_{EFF(PEAK)} + 8 \text{ A}$ 10b: Threshold = $4 \times I_{EFF(PEAK)} + 10 \text{ A}$ 11b: Threshold = $4 \times I_{EFF(PEAK)} + 12 \text{ A}$
8:7	DPS_3TO4_FINE_ADD (PAGE 0 only)	RW	NVM	Dynamic phase add threshold, fine adjustment, 3 phases to 4 phases. Set as an offset from peak efficiency point per phase in Amperes. Phases add when peak phase current reaches the stated threshold. $I_{EFF(PEAK)}$ refers to the value selected by DPS_COURSE_TH below 00b: Threshold = $3 \times I_{EFF(PEAK)} + 6 \text{ A}$ 01b: Threshold = $3 \times I_{EFF(PEAK)} + 8 \text{ A}$ 10b: Threshold = $3 \times I_{EFF(PEAK)} + 10 \text{ A}$ 11b: Threshold = $3 \times I_{EFF(PEAK)} + 12 \text{ A}$
6:5	DPS_2TO3_FINE_ADD	RW	NVM	Dynamic phase add threshold, fine adjustment, 2 phases to 3 phases. Set as an offset from peak efficiency point per phase in Amperes. Phases add when peak phase current reaches the stated threshold. $I_{EFF(PEAK)}$ refers to the value selected by DPS_COURSE_TH below 00b: Threshold = $2 \times I_{EFF(PEAK)} + 6 \text{ A}$ 01b: Threshold = $2 \times I_{EFF(PEAK)} + 8 \text{ A}$ 10b: Threshold = $2 \times I_{EFF(PEAK)} + 10 \text{ A}$ 11b: Threshold = $2 \times I_{EFF(PEAK)} + 12 \text{ A}$

**表 63. MFR\_SPECIFIC\_15 Register Field Descriptions (接下页)**

Bit	Field	Type	Reset	Description
5:4	DPS_1TO2_FINE_ADD	RW	NVM	Dynamic phase add threshold, fine adjustment, 1 phase to 2 phases. Set as an offset from peak efficiency point per phase in Amperes. Phases add when peak phase current reaches the stated threshold. $I_{EFF(PEAK)}$ refers to the value selected by DPS_COURSE_TH below 00b: Threshold = $1 \times I_{EFF(PEAK)} + 6A$ 01b: Threshold = $1 \times I_{EFF(PEAK)} + 8A$ 10b: Threshold = $1 \times I_{EFF(PEAK)} + 10A$ 11b: Threshold = $1 \times I_{EFF(PEAK)} + 12A$
3	2TO1_PH_EN	RW	NVM	Enable phase dropping from 2 phases to 1 phase operation. 0b: Disable phase shedding to 1 phase 1b: Enable phase shedding to 1 phase
2:0	DPS_COURSE_TH	RW	NVM	Sets the peak efficiency point per phase. This is used to determine phase add/drop thresholds. 00b: $I_{EFF(PEAK)} = 12A$ 01b: $I_{EFF(PEAK)} = 14A$ 10b: $I_{EFF(PEAK)} = 16A$ 11b: $I_{EFF(PEAK)} = 18A$

### 7.5.22 NVM Programming

The USER\_DATA\_00 - USER\_DATA\_12 commands are provided to streamline NVM programming. These 6-byte block commands are mapped internally to all of the user-configurable parameters the TPS53681 supports. The MFR\_SERIAL command also provides a checksum, to streamline verification of desired programming values.

The generalized procedure for programming the TPS53681 is summarized below.

#### Configure User-Programmable Parameters

1. First, configure all of the user-accessible parameters via the standard PMBus, and Manufacturer Specific commands. TI provides the [Fusion Digital Power Designer](#) graphical interface software to streamline this step. The user can also refer to the *Technical Reference Manual* for a full set of register maps for these commands.
2. Once the device is configured as desired, issue the STORE\_DEFAULT\_ALL command to commit these values to NVM, and update the checksum value. Wait approximately 100 ms after issuing STORE\_DEFAULT\_ALL before communicating with the device again.
3. Write PAGE to 00h
4. Read-back and Record the value of IC\_DEVICE\_ID and IC\_DEVICE\_REV commands
5. Read-back and Record the value of the USER\_DATA\_00 through USER\_DATA\_12 commands
6. Read-back and Record the value of the MFR\_SERIAL command
7. Read-back and Record the value of VOUT\_MAX
8. Write PAGE to 01h
9. Read-back and Record the value of VOUT\_MAX

#### Program and Verify NVM (repeat for each device)

1. Power the device by supplying +3.3V to the V3P3 pin. Power conversion should be disabled for NVM programming.
2. Read-back and verify that IC\_DEVICE\_ID and IC\_DEVICE\_REV values match those recorded previously. This ensures that user-parameters being programmed correspond to the same device/revision as previously configured.
3. Write PAGE to 00h.
4. Write the USER\_DATA\_00 through USER\_DATA\_12 commands, with the values recorded previously.
5. Write VOUT\_MAX (Page 0) with the value recorded previously.
6. Write PAGE to 01h
7. Write VOUT\_MAX (Page 1) with the value recorded previously.
8. Issue STORE\_DEFAULT\_ALL. Wait appx 100 ms after issuing STORE\_DEFAULT\_ALL before communicating with the device again.
9. Read-back the MFR\_SERIAL command, and compare the value to that recorded previously. If the new MFR\_SERIAL matches the value recorded previously, NVM programming was successful.

### 7.5.23 NVM Security

The `MFR_SPECIFIC_42` command can be optionally used to set a password for NVM programming. To prevent a hacker from simply sending the password command with all possible passwords, the TPS53681 goes into a special extra-secure state when an incorrect password is received. In this state, all passwords are rejected, even the valid one. The device must be power cycled to clear this state so that another password attempt may be made. When NVM security is enabled, the TPS53681 will not accept writes to any command other than PAGE and PHASE, which are necessary for reading certain parameters.

#### Enabling NVM Security

1. Set the NVM password. Write `MFR_SPECIFIC_42` to a value other than `FFFFh`.
2. Issue `STORE_DEFAULT_ALL`
3. Wait 100ms for the NVM store to complete
4. Power cycle V3P3. NVM Security will be enabled at the next power-up.

#### Disabling NVM Security

To disable NVM security, use the following procedure:

1. Write the password to `MFR_SPECIFIC_42` to disable NVM security. Once the correct password has been given, NVM security will be disabled, and the device will once again accept write transactions to configuration registers.

NVM security will be re-enabled at the next power-on, unless `MFR_SPECIFIC_42` is set to `FFFFh` (NVM Security Disabled), and an NVM store operation (issue `STORE_DEFAULT_ALL` and wait 100 ms) is performed.

#### Determining Whether NVM Security is Active

Reads to the `MFR_SPECIFIC_42` command returns one of three values:

- `0000h` = NVM Security is Disabled
- `0001h` = NVM Security is Enabled
- `0002h` = `MFR_SPECIFIC_42` is locked due to incorrect password entry

##### 7.5.23.1 (FAh) MFR\_SPECIFIC\_42

`MFR_SPECIFIC_42` is used for NVM Security. The `MFR_SPECIFIC_42` command must be accessed through Read Word/Write Word transactions.

`MFR_SPECIFIC_42` is a shared register. Write transactions to this register will apply to both channels, and read transactions to this register returns the same data regardless of the current PAGE.

15	14	13	12	11	10	9	8
RW	RW	RW	RW	RW	RW	RW	RW
NVM_SECURITY_KEY							
7	6	5	4	3	2	1	0
RW	RW	RW	RW	RW	RW	RW	RW
NVM_SECURITY_KEY							

LEGEND: R/W = Read/Write; R = Read only

图 56. MFR\_SPECIFIC\_42

表 64. MFR\_SPECIFIC\_42 Register Field Descriptions

Bit	Field	Type	Reset	Description
7:0	NVM_SECURITY_KEY	RW	NVM	16 bit code for NVM security key.

### 7.5.24 Black Box Recording

The TPS53681 provides a "black box" feature to aid in system-level debugging. According to the PMBus specification, status bits are latched whenever the condition causing them occurs, regardless of whether or not other status bits are already set. This, however, makes it difficult for the system designer to understand which fault condition occurred first, in the case that one fault condition causes others to trigger. The [MFR\\_SPECIFIC\\_08](#) command provides a "snapshot" of the first faults to occur chronologically, for each channel, which may be stored to NVM, for future debugging. Only the most catastrophic fault conditions are logged, such as the over-voltage fault, over-current fault, and power stage failure. The black box command may also be reset, or cleared by writing 00h to the register, and storing to NVM if the NVM value must also be cleared.

#### Resetting the Black Box Record

Resetting the record allows the user to determine which faults occur first, *after* the register is cleared. To clear the record, write 00h to [MFR\\_SPECIFIC\\_08](#), and issue STORE\_DEFAULT\_ALL.

#### Triggering Black Box Recording

Black box recording is always active, whether or not the TPS53681 is converting power. Note however many of the critical faults summarized in [MFR\\_SPECIFIC\\_08](#) are only possible to trigger during power conversion. Whenever any of the following catastrophic faults occur, the MFR\_SPECIFIC\_08 register will be updated according to the register description below, but only if the black box record has been cleared since the last catastrophic faults occurred. Faults logged include:

- Overvoltage Fault (Device was Converting Power)
- Overvoltage Fault (Device was not Converting Power)
- Input Overcurrent Fault
- Output Overcurrent Fault
- Power Stage Fault
- Input Over-Power Fault

#### Retrieving the Black Box Record

Reading the [MFR\\_SPECIFIC\\_08](#) returns the current value of the Black Box record. If the register reads 00h, no catastrophic faults have occurred since the record was last cleared. If any value other than 00h is stored in the register, then de-code the value according to the register description below. In order to read-back the black box record following a power-down, the STORE\_DEFAULT\_ALL command must be issued, to store the contents of the black box record to NVM.

##### 7.5.24.1 (D8h) MFR\_SPECIFIC\_08

The MFR\_SPECIFIC\_08 command is used to identify catastrophic faults which occur first, and store this information to NVM. The MFR\_SPECIFIC\_08 command must be accessed through Write Byte/Read Byte transactions. MFR\_SPECIFIC\_08 is a shared register. Transactions to this register do not require specific PAGE settings. However, note that channels A and B have independent bit fields within the command.

7	6	5	4	3	2	1	0
R	R	RW	RW	RW	RW	RW	RW
0	0	CF_CHB			CF_CHA		

LEGEND: R/W = Read/Write; R = Read only

**图 57. MFR\_SPECIFIC\_08**

**表 65. MFR\_SPECIFIC\_08 Register Field Descriptions**

Bit	Field	Type	Reset	Description
7:6	Not used	R	0	Not used and set to 0.
5:3	CF_CHB	RW	NVM	Catastrophic fault record for channel B.
2:0	CF_CHA	RW	NVM	Catastrophic fault record for channel A.

Whenever a catastrophic fault occurs, the first event detected will trigger the MFR\_SPECIFIC\_08 command to update according to the tables below. This recording happens independently for channel A and channel B. If the PMBus host issues a STORE\_DEFAULT\_ALL, this information will be committed to NVM, and may be retrieved at a later time. In order to clear the record for either channel, the PMBus host must write the corresponding bits (CF\_CHA for channel A, CF\_CHB for channel B) to 000b, and issue STORE\_DEFAULT\_ALL.

Attempts to write any non-zero value to this command will be treated as invalid data - data will be ignored, the appropriate flags in STATUS\_CML, and STATUS\_WORD, will be set, and the PMB\_ALERT pin will be asserted to notify the host of the invalid transaction.

**表 66. Catastrophic Fault Recording Interpretation**

CF_CHA / CF_CHB (binary)	Interpretation
000b	No fault occurred
001b	OVF occurred, power conversion was disabled
010b	OVF occurred, power conversion was enabled
011b	IIN Overcurrent fault occurred
100b	IOUT Overcurrent fault occurred
101b	Overtemperature fault occurred
110b	Power stage fault occurred
111b	Input overpower warning occurred

### 7.5.25 Board Identification and Inventory Tracking

The TPS53681 provides several bytes of arbitrarily programmable NVM-backed memory to allow for inventory management and board identification. By default, these values reflect information about the date/revision of the TPS53681 device being used itself. However, they may be re-programmed by the user, at the board level during manufacturing. This provides a convenient and easy to use method of tracking boards, revisions and manufacturing dates. The following commands are provided for this purpose:

- **MFR\_ID** - 16 bits of NVM for end-users to track the PCB/power supply supplier name
- **MFR\_MODEL** - 16 bits of NVM for tracking the manufacturer model number
- **MFR\_REVISION** - 16 bits of NVM for tracking PCB/power supply revision code
- **MFR\_DATE** - 16 bits of NVM for tracking PCB manufacturing date code

#### 7.5.25.1 (9Ah) MFR\_MODEL

The MFR\_MODEL command is used to either set or read the manufacturer's model number.

The MFR\_MODEL command must be accessed through Block Write/Block Read transactions.

The MFR\_MODEL command is shared between Channel A and Channel B. All transactions to this command will affect both channels regardless of the PAGE command.

15	14	13	12	11	10	9	8
RW	RW	RW	RW	RW	RW	RW	RW
MFR_MODEL							
7	6	5	4	3	2	1	0
RW	RW	RW	RW	RW	RW	RW	RW
MFR_MODEL							

LEGEND: R/W = Read/Write; R = Read only

**图 58. MFR\_MODEL**
**表 67. MFR\_MODEL Register Field Descriptions**

Bit	Field	Type	Reset	Description
15:0	MFR_MODEL	RW	NVM	Arbitrary 16 bits with NVM backup for Model number identification

### 7.5.25.2 (9Bh) MFR\_REVISION

The MFR\_REVISION command is used to either set or read the manufacturer's revision number

The MFR\_REVISION command must be accessed through Block Write/Block Read transactions.

The MFR\_REVISION command is shared between Channel A and Channel B. All transactions to this command will affect both channels regardless of the PAGE command.

15	14	13	12	11	10	9	8
RW	RW	RW	RW	RW	RW	RW	RW
MFR_REV							
7	6	5	4	3	2	1	0
RW	RW	RW	RW	RW	RW	RW	RW
MFR_REV							

LEGEND: R/W = Read/Write; R = Read only

**图 59. MFR\_REVISION**

**表 68. MFR\_REVISION Register Field Descriptions**

Bit	Field	Type	Reset	Description
15:0	MFR_REV	RW	NVM	Arbitrary 16 bits with NVM backup for revision number identification

### 7.5.25.3 (9Dh) MFR\_DATE

The MFR\_DATE command is used to either set or read the manufacturing date.

The MFR\_DATE command must be accessed through Block Write/Block Read transactions.

The MFR\_DATE command is shared between Channel A and Channel B. All transactions to this command will affect both channels regardless of the PAGE command.

15	14	13	12	11	10	9	8
RW	RW	RW	RW	RW	RW	RW	RW
MFR_DATE							
7	6	5	4	3	2	1	0
RW	RW	RW	RW	RW	RW	RW	RW
MFR_DATE							

LEGEND: R/W = Read/Write; R = Read only

**图 60. MFR\_DATE**

**表 69. MFR\_DATE Register Field Descriptions**

Bit	Field	Type	Reset	Description
15:0	MFR_DATE	RW	NVM	Arbitrary 16 bits with NVM backup for manufacture date identification

## 7.5.26 Status Reporting

The TPS53681 provides several registers containing status information. The flags in these registers are latched whenever their corresponding condition occurs, and are not cleared until either the CLEAR\_FAULTS command is issued, or the host writes a value of 1b to that bit location. Register maps for the all of the supported status registers are shown in the following sections.

### 7.5.26.1 (78h) STATUS\_BYTE

The STATUS\_BYTE command returns one byte of information with a summary of the most critical faults, such as over-voltage, overcurrent, over-temperature, etc.

The STATUS\_BYTE command must be accessed through Read Byte transactions. STATUS\_BYTE is a paged register. In order to access STATUS\_BYTE command for channel A, PAGE must be set to 00h. In order to access STATUS\_BYTE register for channel B, PAGE must be set to 01h. If PAGE is set FFh, the device return value will reflect the status of Channel A.

7	6	5	4	3	2	1	0
0	R	R	R	R	R	R	R
BUSY	OFF	VOUT_OV	IOUT_OC	VIN_UV	TEMP	CML	OTHER

图 61. STATUS\_BYTE

表 70. STATUS\_BYTE Register Field Descriptions

Bit	Field	Type	Reset	Description
7	BUSY	R	0	Not supported and always set to 0.
6	OFF	R	Current Status	This bit is asserted if the unit is not providing power to the output, regardless of the reason, including simply not being enabled. 0: Raw status indicating the IC is providing power to VOUT. 1: Raw status indicating the IC is not providing power to VOUT.
5	VOUT_OV	R	Current Status	Output Over-Voltage Fault Condition 0: Latched flag indicating no VOUT OV fault has occurred. 1: Latched flag indicating a VOUT OV fault occurred
4	IOUT_OC	R	Current Status	Output Over-Current Fault Condition 0: Latched flag indicating no IOUT OC fault has occurred. 1: Latched flag indicating an IOUT OC fault has occurred.
3	VIN_UV	R	Current Status	Input Under-Voltage Fault Condition 0: Latched flag indicating VIN is above the UVLO threshold. 1: Latched flag indicating VIN is below the UVLO threshold.
2	TEMP	R	Current Status	Over-Temperature Fault/Warning 0: Latched flag indicating no OT fault or warning has occurred. 1: Latched flag indicating an OT fault or warning has occurred.
1	CML	R	Current Status	Communications, Memory or Logic Fault 0: Latched flag indicating no communication, memory, or logic fault has occurred. 1: Latched flag indicating a communication, memory, or logic fault has occurred.
0	OTHER	R	Current Status	Other Fault (None of the Above) This bit is used to flag faults not covered with the other bit faults. In this case, UVF or OCW faults are examples of other faults not covered by the bits [7:1] in this register. 0: No fault has occurred 1: A fault or warning not listed in bits [7:1] has occurred.

Per the description in the PMBus 1.3 specification, part II, TPS53681 does support clearing of status bits by writing to STATUS registers. However, the bits in the STATUS\_BYTE are summary bits only and reflect the status of corresponding bits in STATUS\_VOUT, STATUS\_IOUT, etc... To clear these bits individually, the user must clear them by writing to the corresponding STATUS\_X register. For example: the output overcurrent fault sets the IOUT\_OC bit in STATUS\_BYTE, and the IOUT\_OC\_FLT bit in STATUS\_IOUT. Writing a 1 to the IOUT\_OC\_FLT bit in STATUS\_IOUT clears the fault in both STATUS\_BYTE and STATUS\_IOUT. Writes to STATUS\_BYTE itself will be treated as invalid transactions.

### 7.5.26.2 (79h) STATUS\_WORD

The STATUS\_WORD command returns two bytes of information with a summary of critical faults, such as over-voltage, overcurrent, over-temperature, etc..

The STATUS\_WORD command must be accessed through Read Word transactions. STATUS\_WORD is a paged register. In order to access STATUS\_WORD command for channel A, PAGE must be set to 00h. In order to access STATUS\_WORD register for channel B, PAGE must be set to 01h. If PAGE is set FFh, the device return value will reflect the status of Channel A.

15	14	13	12	11	10	9	8
R	R	R	R	R	R	R	R
VOUT	IOUT	INPUT	MFR	PGOOD	FANS	OTHER	UNKNOWN
7	6	5	4	3	2	1	0
R	R	R	R	R	R	R	R
BUSY	OFF	VOUT_OV	IOUT_OC	VIN_UV	TEMP	CML	OTHER

图 62. STATUS\_WORD

表 71. STATUS\_WORD Register Field Descriptions

Bit	Field	Type	Reset	Description
15	VOUT	R	Current Status	Output Voltage Fault/Warning. Refer to STATUS_VOUT for more information. 0: Latched flag indicating no VOUT fault or warning has occurred. 1: Latched flag indicating a VOUT fault or warning has occurred.
14	IOUT	R	Current Status	Output Current Fault/Warning. Refer to STATUS_IOUT for more information. 0: Latched flag indicating no IOUT fault or warning has occurred. 1: Latched flag indicating an IOUT fault or warning has occurred.
13	INPUT	R	Current Status	Input Voltage/Current Fault/Warning. Refer to STATUS_INPUT for more information. 0: Latched flag indicating no VIN or IIN fault or warning has occurred. 1: Latched flag indicating a VIN or IIN fault or warning has occurred.
12	MFR	R	Current Status	MFR_SPECIFIC Fault. Refer to STATUS_MFR for more information. 0: Latched flag indicating no MFR_SPECIFIC fault has occurred. 1: Latched flag indicating a MFR_SPECIFIC fault has occurred.
11	PGOOD	R	Current Status	Power Good Status. Note: Per the PMBus specification, the PGOOD bit is not latched, always reflecting the current status of the AVR_RDY/BVR_RDY pin. 0: Raw status indicating AVR_RDY/BVR_RDY pin is at logic high. 1: Raw status indicating AVR_RDY/BVR_RDY pin is at logic low.
10	FANS	R	0	Not supported and always set to 0.
9	OTHER	R	0	Not supported and always set to 0.
8	UNKNOWN	R	0	Not supported and always set to 0.
7	BUSY	R	0	Not supported and always set to 0.
6	OFF	R	Current Status	This bit is asserted if the unit is not providing power to the output, regardless of the reason, including simply not being enabled. 0: Raw status indicating the IC is providing power to VOUT. 1: Raw status indicating the IC is not providing power to VOUT.
5	VOUT_OV	R	Current Status	Output Over-Voltage Fault Condition 0: Latched flag indicating no VOUT OV fault has occurred. 1: Latched flag indicating a VOUT OV fault occurred
4	IOUT_OC	R	Current Status	Output Over-Current Fault Condition 0: Latched flag indicating no IOUT OC fault has occurred. 1: Latched flag indicating an IOUT OC fault has occurred.

**表 71. STATUS\_WORD Register Field Descriptions (接下页)**

Bit	Field	Type	Reset	Description
3	VIN_UV	R	Current Status	Input Under-Voltage Fault Condition 0: Latched flag indicating VIN is above the UVLO threshold. 1: Latched flag indicating VIN is below the UVLO threshold.
2	TEMP	R	Current Status	Over-Temperature Fault/Warning 0: Latched flag indicating no OT fault or warning has occurred. 1: Latched flag indicating an OT fault or warning has occurred.
1	CML	R	Current Status	Communications, Memory or Logic Fault 0: Latched flag indicating no communication, memory, or logic fault has occurred. 1: Latched flag indicating a communication, memory, or logic fault has occurred.
0	OTHER	R	Current Status	Other Fault (None of the Above) This bit is used to flag faults not covered with the other bit faults. In this case, UVF or OCW faults are examples of other faults not covered by the bits [7:1] in this register. 0: No fault has occurred 1: A fault or warning not listed in bits [7:1] has occurred.

Per the description in the PMBus 1.3 specification, part II, TPS53681 does support clearing of status bits by writing to STATUS registers. However, the bits in the STATUS\_WORD are summary bits only and reflect the status of corresponding bits in STATUS\_VOUT, STATUS\_IOUT, etc... To clear these bits individually, the user must clear them by writing to the corresponding STATUS\_X register. For example: the output overcurrent fault sets the IOUT\_OC bit in STATUS\_WORD, and the IOUT\_OC\_FLT bit in STATUS\_IOUT. Writing a 1 to the IOUT\_OC\_FLT bit in STATUS\_IOUT clears the fault in both STATUS\_WORD and STATUS\_IOUT. Writes to STATUS\_WORD will be treated as invalid transactions.

### 7.5.26.3 (7Ah) STATUS\_VOUT

The STATUS\_VOUT command returns one byte of information relating to the status of the converter's output voltage related faults.

The STATUS\_VOUT command must be accessed through Read Byte/Write Byte transactions. STATUS\_VOUT is a paged register. In order to access STATUS\_VOUT command for channel A, PAGE must be set to 00h. In order to access STATUS\_VOUT register for channel B, PAGE must be set to 01h. If PAGE is set FFh, the device return value will reflect the status of Channel A.

7	6	5	4	3	2	1	0
RW	0	0	RW	RW	0	0	0
VOUT_OVF	VOUT_OVW	VOUT_UVW	VOUT_UVF	VOUT_MIN_MAX	TON_MAX	TOFF_MAX	VOUT_TRACK

**图 63. STATUS\_VOUT**
**表 72. STATUS\_VOUT Register Field Descriptions**

Bit	Field	Type	Reset	Description
7	VOUT_OVF	RW	Current Status	Output Over-Voltage Fault 0: Latched flag indicating no VOUT OV fault has occurred. 1: Latched flag indicating a VOUT OV fault has occurred.
6	VOUT_OVW	R	0	Not supported and always set to 0.
5	VOUT_UVW	R	0	Not supported and always set to 0.
4	VOUT_UVF	RW	Current Status	Output Under-Voltage Fault 0: Latched flag indicating no VOUT UV fault has occurred. 1: Latched flag indicating a VOUT UV fault has occurred.

**表 72. STATUS\_VOUT Register Field Descriptions (接下页)**

Bit	Field	Type	Reset	Description
3	VOUT_MIN_MAX	RW	Current Status	Output Voltage Max/Min Exceeded Warning 0: Latched flag indicating no VOUT_MAX/VOUT_MIN warning has occurred. 1: Latched flag indicating that an attempt has been made to set the output voltage to a value higher than allowed by the VOUT_MAX/VOUT_MIN command.
2	TON_MAX	R	0	Not supported and always set to 0.
1	TOFF_MAX	R	0	Not supported and always set to 0.
0	VOUT_TRACK	R	0	Not supported and always set to 0.

Per the description in the PMBus 1.3 specification, part II, TPS53681 does support clearing of status bits by writing to STATUS registers. Writing a 1 to any supported bit in this register will attempt to clear it as a fault condition.

#### 7.5.26.4 (7Bh) STATUS\_IOUT

The STATUS\_IOUT command returns one byte of information relating to the status of the converter's output current related faults.

The STATUS\_IOUT command must be accessed through Read Byte/Write Byte transactions. STATUS\_IOUT is a paged register. In order to access STATUS\_IOUT command for channel A, PAGE must be set to 00h. In order to access STATUS\_IOUT register for channel B, PAGE must be set to 01h. If PAGE is set FFh, the device return value will reflect the status of Channel A.

7	6	5	4	3	2	1	0
RW	0	RW	0	RW	0	0	0
IOUT_OCF	IOUT_OCUVF	IOUT_OCW	IOUT_UCF	CUR_SHAREF	POW_LIMIT	POUT_OPF	POUT_OPW

**图 64. STATUS\_IOUT**
**表 73. STATUS\_IOUT Register Field Descriptions**

Bit	Field	Type	Reset	Description
7	IOUT_OCF	RW	Current Status	Output Over-Current Fault 0: Latched flag indicating no IOUT OC fault has occurred. 1: Latched flag indicating a IOUT OC fault has occurred .
6	IOUT_OCUVF	R	0	Not supported and always set to 0.
5	IOUT_OCW	RW	Current Status	0: Latched flag indicating no IOUT OC warning has occurred 1: Latched flag indicating a IOUT OC warning has occurred
4	IOUT_UCF	R	0	Not supported and always set to 0.
3	CUR_SHAREF	RW	Current Status	0: Latched flag indicating no current sharing fault has occurred 1: Latched flag indicating a current sharing fault has occurred
2	POW_LIMIT	R	0	Not supported and always set to 0.
1	POUT_OPF	R	0	Not supported and always set to 0.
0	POUT_OPW	R	0	Not supported and always set to 0.

Per the description in the PMBus 1.3 specification, part II, TPS53681 does support clearing of status bits by writing to STATUS registers. Writing a 1 to any supported bit in this register will attempt to clear it as a fault condition.

#### 7.5.26.5 (7Ch) STATUS\_INPUT

The STATUS\_INPUT command returns one byte of information relating to the status of the converter's input voltage and current related faults.

The STATUS\_INPUT command must be accessed through Read Byte/Write Byte transactions. The STATUS\_INPUT command is shared between Channel A and Channel B. All transactions to this command will affect both channels regardless of the PAGE command.

7	6	5	4	3	2	1	0
RW	0	0	RW	RW	RW	RW	RW
VIN_OVF	VIN_OVW	VIN_UVW	VIN_UVF	LOW_VIN	IIN_OCF	IIN_OCW	PIN_OPW

图 65. STATUS\_INPUT Register

表 74. STATUS\_INPUT Register Field Descriptions

Bit	Field	Type	Reset	Description
7	VIN_OVF	R	Current Status	Input Over-Voltage Fault 0: Latched flag indicating no VIN OV fault has occurred. 1: Latched flag indicating a VIN OV fault has occurred.
6	VIN_OVW	R	0	Not supported and always set to 0.
5	VIN_UVW	R	0	Not supported and always set to 0.
4	VIN_UVF	R	Current Status	Input Under-Voltage Fault 0: Latched flag indicating no VIN UV fault has occurred. 1: Latched flag indicating a VIN UV fault has occurred.
3	LOW_VIN	R	Current Status	Unit Off for insufficient input voltage 0: Latched flag indicating no LOW_VIN fault has occurred. 1: Latched flag indicating a LOW_VIN fault has occurred
2	IIN_OCF	R	Current Status	Input Over-Current Fault 0: Latched flag indicating no IIN OC fault has occurred. 1: Latched flag indicating a IIN OC fault has occurred.
1	IIN_OCW	R	Current Status	Input Over-Current Warning 0: Latched flag indicating no IIN OC warning has occurred. 1: Latched flag indicating a IIN OC warning has occurred.
0	PIN_OPW	R	Current Status	Input Over-Power Warning 0: Latched flag indicating no input over-power warning has occurred. 1: Latched flag indicating a input over-power warning has occurred.

Per the description in the PMBus 1.3 specification, part II, TPS53681 does support clearing of status bits by writing to STATUS registers. Writing a 1 to any supported bit in this register will attempt to clear it as a fault condition.

### 7.5.26.6 (7Dh) STATUS\_TEMPERATURE

The STATUS\_TEMPERATURE command returns one byte of information relating to the status of the converter's temperature related faults.

The STATUS\_TEMPERATURE command must be accessed through Read Byte/Write Byte transactions. STATUS\_TEMPERATURE is a paged register. In order to access STATUS\_TEMPERATURE command for channel A, PAGE must be set to 00h. In order to access STATUS\_TEMPERATURE register for channel B, PAGE must be set to 01h. If PAGE is set FFh, the device return value will reflect the status of Channel A.

7	6	5	4	3	2	1	0
RW	RW	0	0	0	0	0	0
OTF	OTW	UTW	UTF	Reserved			

图 66. STATUS\_TEMPERATURE Register

表 75. STATUS\_TEMPERATURE Register Field Descriptions

Bit	Field	Type	Reset	Description
7	OTF	RW	Current Status	Over-Temperature Fault 0: (Default) A temperature fault has not occurred. 1: A temperature fault has occurred.
6	OTW	RW	Current Status	Over-Temperature Warning 0: (Default) A temperature warning has not occurred. 1: A temperature warning has occurred.

**表 75. STATUS\_TEMPERATURE Register Field Descriptions (接下页)**

Bit	Field	Type	Reset	Description
5	UTW	R	0	Not supported and always set to 0.
4	UTF	R	0	Not supported and always set to 0.
3-0	Reserved	R	0000	Always set to 0.

Per the description in the PMBus 1.3 specification, part II, TPS53681 does support clearing of status bits by writing to STATUS registers. Writing a 1 to any supported bit in this register will attempt to clear it as a fault condition.

#### 7.5.26.7 (7Eh) STATUS\_CML

The STATUS\_CML command returns one byte with contents regarding communication, logic, or memory conditions.

The STATUS\_CML command must be accessed through Read Byte/Write Byte transactions. The STATUS\_CML command is shared between Channel A and Channel B. All transactions to this command will affect both channels regardless of the PAGE command.

7	6	5	4	3	2	1	0
RW	RW	RW	RW	0	0	RW	0
IV_CMD	IV_DATA	PEC_FAIL	MEM	PRO_FAULT	Reserved	COM_FAIL	CML_OTHER

**图 67. STATUS\_CML Register**
**表 76. STATUS\_CML Register Field Descriptions**

Bit	Field	Type	Reset	Description
7	IV_CMD	RW	Current Status	Invalid or Unsupported Command Received 0: Latched flag indicating no invalid or unsupported command has been received. 1: Latched flag indicating an invalid or unsupported command has been received.
6	IV_DATA	RW	Current Status	Invalid or Unsupported Data Received 0: Latched flag indicating no invalid or unsupported data has been received. 1: Latched flag indicating an invalid or unsupported data has been received.
5	PEC_FAIL	RW	Current Status	Packet Error Check Failed 0: Latched flag indicating no packet error check has failed 1: Latched flag indicating a packet error check has failed
4	Reserved	R	0	Always set to 0.
3	MEM	RW	Current Status	Memory/NVM Error 0: Latched flag indicating no memory error has occurred 1: Latched flag indicating a memory error has occurred
2	Reserved	R	0	Always set to 0.
1	COM_FAIL	RW	Current Status	Other Communication Faults 0: Latched flag indicating no communication fault other than the ones listed in this table has occurred. 1: Latched flag indicating a communication fault other than the ones listed in this table has occurred.
0	CML_OTHER	R	0	Not supported and always set to 0.

Per the description in the PMBus 1.3 specification, part II, TPS53681 does support clearing of status bits by writing to STATUS registers. Writing a 1 to any bit in this register will attempt to clear it as a fault condition.

#### 7.5.26.8 (80h) STATUS\_MFR\_SPECIFIC

The STATUS\_MFR\_SPECIFIC command returns one byte containing manufacturer-defined faults or warnings.

The STATUS\_MFR\_SPECIFIC command must be accessed through Read Byte/Write Byte transactions. STATUS\_MFR\_SPECIFIC is a paged register. In order to access STATUS\_MFR\_SPECIFIC command for channel A, PAGE must be set to 00h. In order to access STATUS\_MFR\_SPECIFIC register for channel B, PAGE must be set to 01h. If PAGE is set FFh, the device return value will reflect the status of Channel A.

**图 68. STATUS\_MFR\_SPECIFIC Register**

7		6		5		4		3		2		1		0	
RW		RW		RW		RW		RW		0		0		RW	
FLT_PS		VSNS_OPEN		MAX_PH_WARN		TSNS_LOW		RST_VID (Page 0)		Reserved				PHFLT	

**表 77. STATUS\_MFR\_SPECIFIC Register Field Descriptions**

Bit	Field	Type	Reset	Description
7	MFR_FAULT_PS	RW	Current Status	Power Stage Fault 0b: Latched flag indicating no fault from TI power stage has occurred. 1b: Latched flag indicating a fault from TI power stage has occurred.
6	VSNS_OPEN	RW	Current Status	VSNS pin open 0b: Latched flag indicating VSNS pin was not open at power-up. 1b: Latched flag indicating VSNS pin was open at power-up.
5	MAX_PH_WARN	RW	Current Status	Maximum Phase Warning If the selected operational phase number is larger than the maximum available phase number specified by the hardware, then MAX_PH_WARN is set, and the operational phase number is changed to the maximum available phase number. 0b: Latched flag indicating no maximum phase warning has occurred. 1b: Latched flag indicating a maximum phase warning has occurred.
4	TSNS_LOW	RW	Current Status	0b: Latched flag indicating that TSEN < 150 mV before soft-start. 1b: Latched flag indicating that TSEN ≥ 150 mV before soft-start.
3	RST_VID (Page 0)	RW	Current Status	RST_VID (Page 0 only) 0b: A VID reset operation has NOT occurred 1b: A VID reset operation has occurred
2:1	Reserved	R	00b	Always set to 0.
0	PHFLT	RW	Current Status	Phase current share fault. The PHFLT bit is set if any phase has current imbalance warnings occurring repetitively for 7 detection cycles (~500 μs continuously). Phases with current imbalance warnings may be read back via MFR_SPECIFIC_03. 0b: No repetitive current share fault has occurred 1b: Repetitive current share fault has occurred

Per the description in the PMBus 1.3 specification, part II, TPS53681 does support clearing of status bits by writing to STATUS registers. Writing a 1 to any supported bit in this register will attempt to clear it as a fault condition.

## 8 Applications, Implementation, and Layout

---

### NOTE

Information in the following Applications section is not part of the TI component specification, and TI does not warrant its accuracy or completeness. TI's customers are responsible for determining suitability of components for their purposes. Customers should validate and test their design implementation to confirm system functionality.

---

### 8.1 Application Information

The TPS53681 device has a very simple design procedure. All programmable parameters can be configured by PMBus and stored in NVM as the new default values to minimize external component count. This design describes a typical 6-phase, 0.9-V, 300-A application and 2-phase 0.8-V, 90-A application.

### 8.2 Typical Application

#### 8.2.1 6-phase, 0.9-V, 300-A Application and 2-phase 0.8-V, 90-A Application

TPS53681

ZHCSGE0B – JUNE 2017 – REVISED JANUARY 2019

www.ti.com.cn

8.2.1.1 Schematic

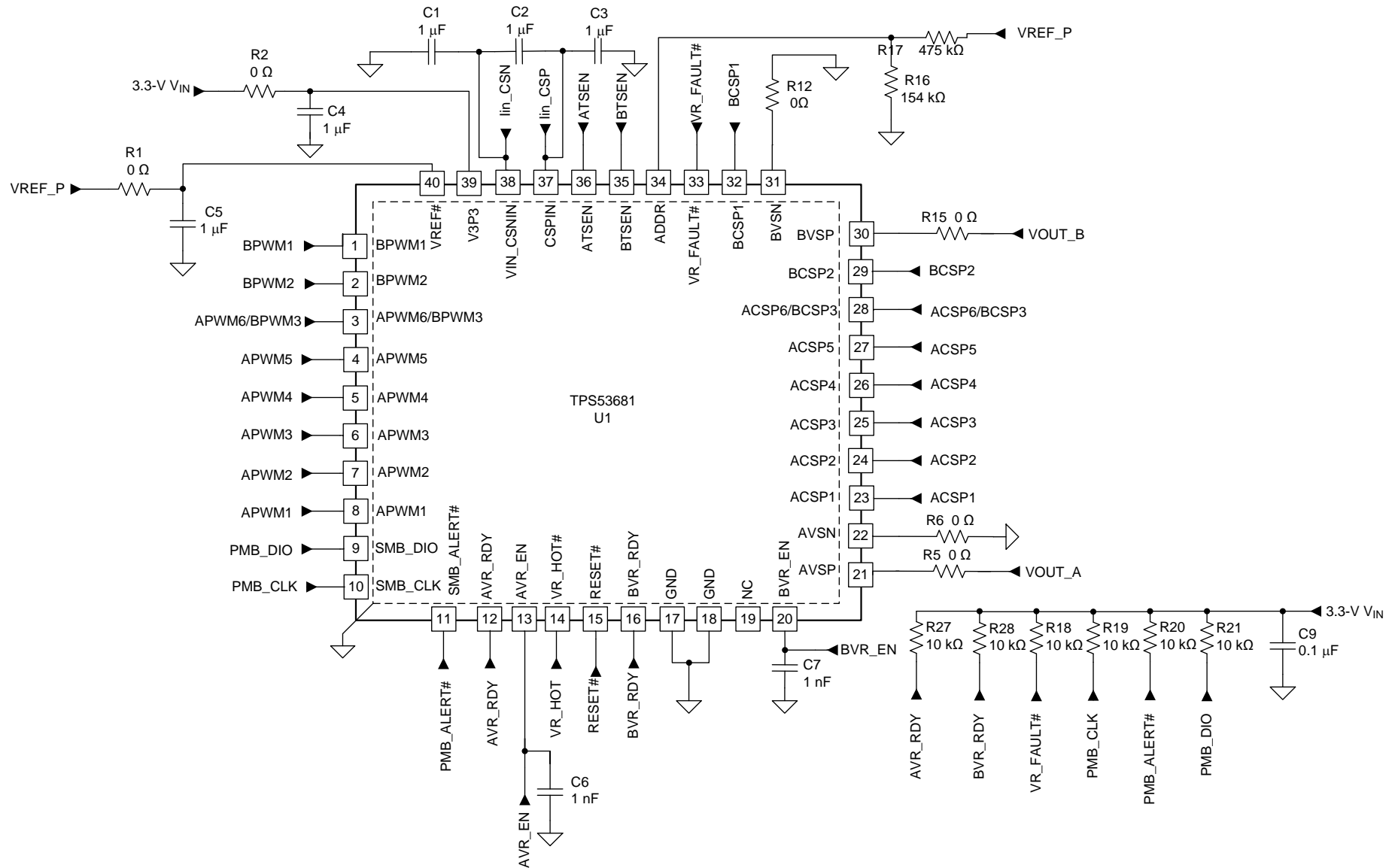

Figure 69. 6-Phase + 2-Phase Application

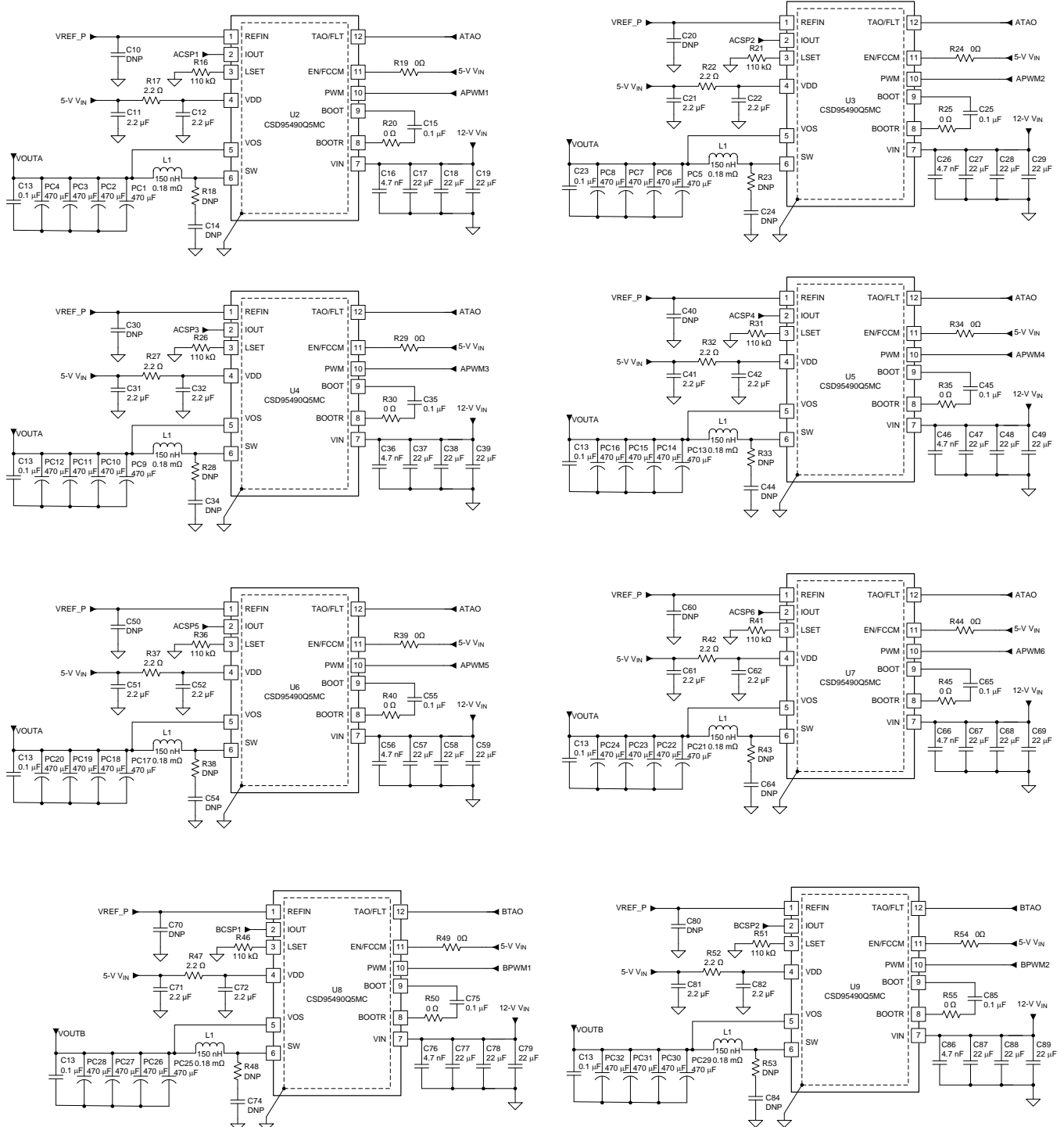

Figure 70. Power Stage

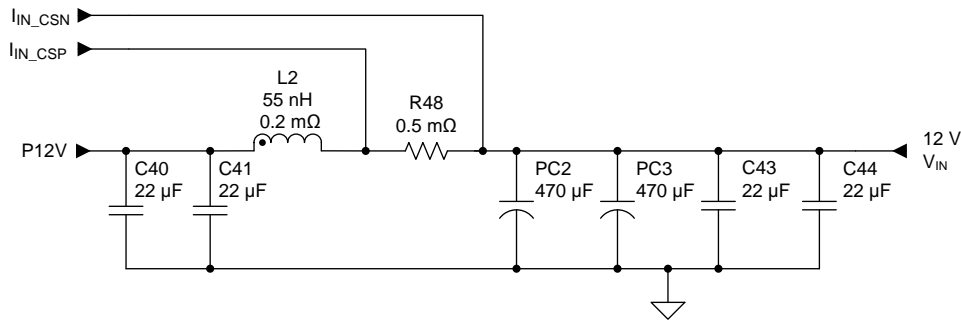

Figure 71. 12-V Input Filter

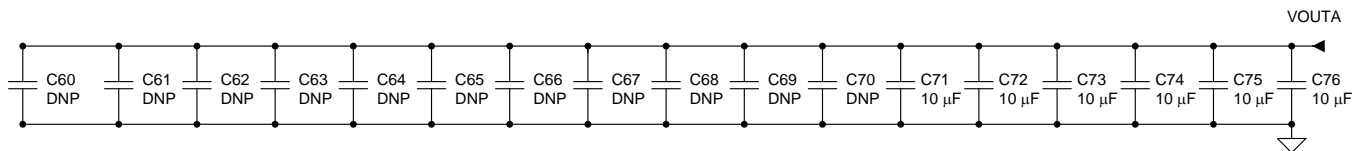

Figure 72. VOUTA Filter for a 6-Phase Application

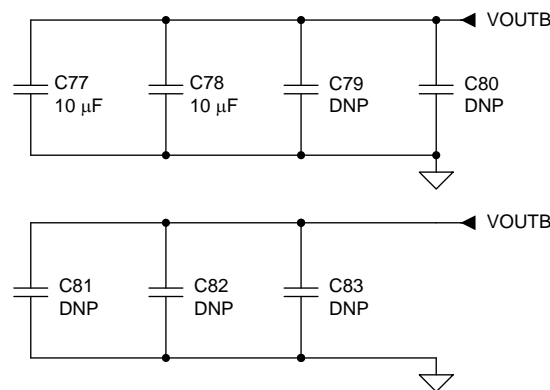

Figure 73. VOUTB Filter for a 2-Phase Application

8.2.1.2 Design Requirements

Table 78. Target Application Specifications

	VOUTA	VOUTB
Number of phases	6	2
Input voltage range	10.8 V – 13.2 V	
Output voltage	0.9 V	0.8 V
I <sub>OUT</sub>	300 A	90 A
I <sub>DYN(max)</sub>	150 A	45 A
Load-line	0 mΩ	0 mΩ
Fast slew rate (min)	10 mV/μs	
Boot voltage, V <sub>BOOT</sub>	0.9 V	0.8 V
Maximum temperature, T <sub>MAX</sub>	90°C	
PMBus Address	1100000 (C0h)	
Switching frequency (f <sub>SW</sub> )	500 kHz	

### 8.2.1.3 Detailed Design Procedure

The following steps illustrate how to configure and fine-tune via PMBus and stored in NVM as the new default setting.

#### 8.2.1.3.1 Choose Inductor

Smaller inductance values yield better transient performance, but also have a higher ripple and lower efficiency. Higher inductance values have the opposite characteristics. It is common practice to limit the ripple current to between 30% and 45% of the maximum per-phase current. In this design example, 30% of the maximum per-phase current is used.

$$I_{P-P} = \frac{I_{OUT}}{n} \times 30\% = \frac{300 \text{ A}}{6} \times 0.3 = 15 \text{ A} \quad (4)$$

$$L \approx \frac{V_{IN(max)} - V_{OUT}}{I_{P-P}} \times \frac{V_{OUT}}{V_{IN(max)}} \times \frac{1}{f_{SW}} = \frac{13.2 \text{ V} - 0.9 \text{ V}}{15 \text{ A}} \times \frac{0.9 \text{ V}}{13.2 \text{ V}} \times \frac{1}{500 \text{ kHz}} = 0.112 \text{ } \mu\text{H} \quad (5)$$

A standard inductor value of 150 nH with 0.18 mΩ DCR is chosen. With the same design procedure, the inductor value for the Rail B ( $V_{OUTB}$ ) of 150 nH is chosen.

#### 8.2.1.3.2 Select the Per-Phase Valley Current Limit

Equation 6 shows the calculation of the per-phase, valley current limit based on the maximum processor current, the operating phase number and the per-phase current ripple  $I_{P-P}$ .

$$I_{OCL} = \left( k \times \frac{I_{OUT}}{n} \right) - \left( \frac{I_{P-P}}{2} \right) = 150\% \times \frac{300 \text{ A}}{6} - \left( \frac{15 \text{ A}}{2} \right) = 67.5 \text{ A}$$

where

- k is the maximum operating margin
- $I_{OUT}$  is the maximum processor current
- $I_{P-P}$  is the ripple current
- n is the number of phases

The factor k of 150% is used to avoid reaching current limits during transients. For this design, a 70-A valley current limit is selected in PMBus GUI.

$$I_{SAT} = I_{OCL} + I_{P-P} = 70 \text{ A} + 15 \text{ A} = 85 \text{ A} \quad (7)$$

Equation 7 indicates that the maximum saturation current for the inductor needs to be higher than 85 A. Using the same design procedure, the valley current limit for Channel B is selected to be 80 A.

#### 8.2.1.3.3 Set the Maximum Temperature Level ( $T_{MAX}$ )

For this design,  $T_{MAX}$  is selected as 90°C. The temperature is sensed by the ATSEN and BTSEN pins through its connection to the xTAO pins of each phase of the CSD95490Q5MC. The controller reports the highest temperature sensed by power stages of Rail A and Rail B.

#### 8.2.1.3.4 Set USR Thresholds to Improve Load Transient Performance

There are two levels of undershoot reduction protection (USR) (USR1/USR2) selection. USR1 enables up to 3 or 4 phases and USR2 enables up to the maximum number of phases. The initial setting of the USR threshold is to start with USR1 and USR2 as OFF, and then to meet the load insertion requirement by lowering the threshold to enable pulse-overlap during the load transients.

For this design, VOUTA USR1 is selected as 240 mV and USR2 is selected as 300 mV. VOUTB USR1 and USR2 are selected as OFF.

### 8.2.1.4 Inductor DCR and Shunt Current Sensing Design for Input Power

This section describes designing the thermal compensation network. The NTC thermistor is used to compensate thermal variations in the resistance of the inductor winding. The winding is usually copper. And as such has a resistance coefficient of 3900 PPM/°C. Alternatively, the NTC thermistor characteristic is very non-linear and requires two or three resistors to linearize them over the range of interest. Figure 74 shows a typical DCR circuit.

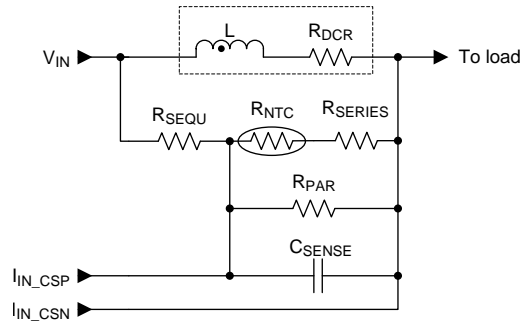
**Figure 74. Typical DCR Current Sensing Circuit**

Equation 8 calculates the voltage across the  $C_{SENSE}$  capacitor when it exactly equals the voltage across  $R_{DCR}$ .

$$C_{SENSE} \times R_{EQ} = \frac{L}{R_{DCR}}$$

where

- $R_{EQ}$  is the series/parallel combination of  $R_{SEQU}$ ,  $R_{NTC}$ ,  $R_{SERIES}$  and  $R_{PAR}$  (8)

$$R_{EQ} = \frac{R_{P\_N} \times R_{SEQU}}{R_{P\_N} + R_{SEQU}} \quad (9)$$

$$R_{P\_N} = \frac{R_{PAR} \times (R_{NTC} + R_{SERIES})}{R_{PAR} + R_{NTC} + R_{SERIES}} \quad (10)$$

Ensure that  $C_{SENSE}$  is a capacitor type which is stable over temperature, use X7R or better dielectric (C0G preferred). Because calculating these values by hand can be time-consuming, TI offers a spreadsheet using the Excel Solver function available to provide calculation assistance. Contact your local TI representative to get a copy of the spreadsheet.

This example uses a simple design process to enable input shunt sensing, so no DCR network is needed. Insert a 0.5-m $\Omega$  shunt resistor in series between the input inductor and the input bulk capacitors.

#### 8.2.1.4.1 Compensation Design

Figure 75 shows the compensation block diagram of the DCAP+ architecture.

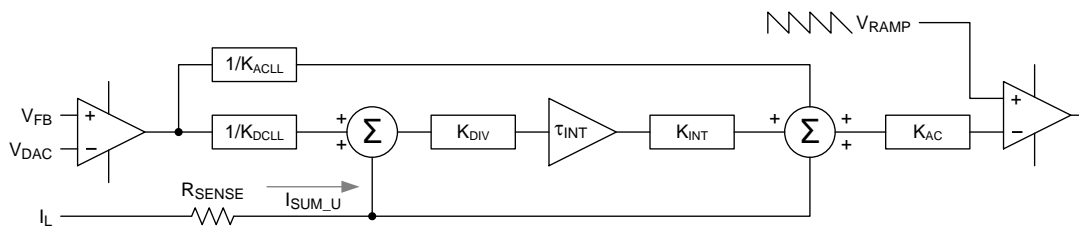
**Figure 75. DCAP+ Compensation Block Diagram**

- $R_{SENSE}$ : typical 5 m $\Omega$  which is gain from power stage
- $K_{DCLL}$ : DC load line which is adjustable from 0 m $\Omega$  to 3.125 m $\Omega$
- $K_{ACLL}$ : AC load line which is adjustable from 0.5 m $\Omega$  to 3.125 m $\Omega$
- $K_{DIV}$ : not be adjustable. Changing DCLL, this parameter changes automatically
- $\tau_{INT}$ : Integrator time constant which is adjustable from 01  $\mu$ s to 08  $\mu$ s (scale = 1  $\mu$ s) and from 10  $\mu$ s to 40  $\mu$ s (scale = 5  $\mu$ s)
- $K_{INT}$ : Integrator time gain which can be adjustable from 0.5x, 0.66x, 1x, 2x
- $K_{AC}$ : AC gain which is adjustable from 0.5x, 1x, 1.5x, 2x

For this design, Table 79 lists the default values that are preset into the PMBus GUI.

**Table 79. PMBus GUI Default Values**

	VOUTA	VOUTB
AC_gain	2x	
AC_LL	0.5 mΩ	
INT_Time	01 μs	10 μs
INTGAIN	2x	

**8.2.1.4.2 Set PMBus Addresses**

To communicate with other system controllers with the PMBus interfaces, use the values of R16 and R17 resistors to set the PMBus address.

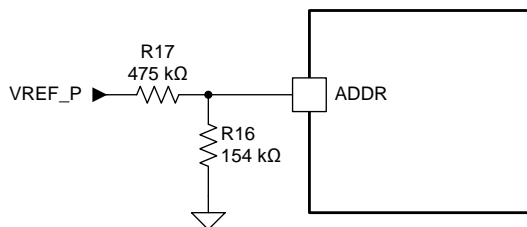

**Figure 76. PMBus Address Setting**

Contact your local Texas Instruments representative for a copy of PMBus address setting design tool spreadsheet.

### 8.2.1.5 Application Performance Plots

For this design, choose 500 kHz for the switching frequency. The frequency is an approximate frequency and is expected to vary based on load and input voltage.



$V_{VIN} = 12\text{ V}$   
 $I_{OUTA} = 10\text{ A}$   
 $V_{VOUT\_A} = 0.9\text{ V}$

Figure 77. VOUT\_A Enable Start-up

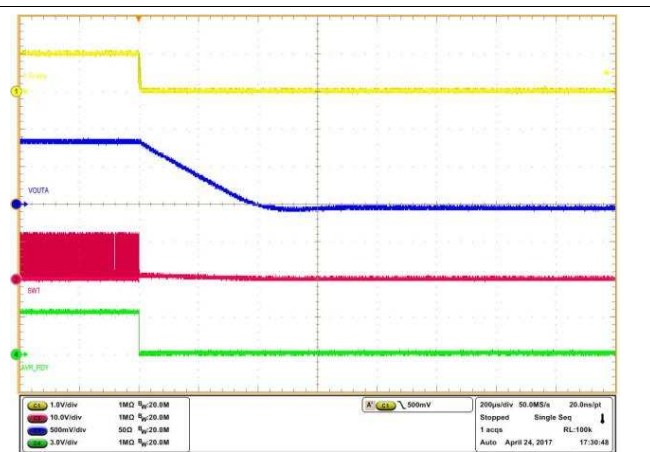

$V_{VIN} = 12\text{ V}$   
 $I_{OUTA} = 10\text{ A}$   
 $V_{VOUT\_A} = 0.9\text{ V}$

Figure 78. VOUT\_A Enable Shut-down



$V_{VIN} = 12\text{ V}$   
 $I_{OUTB} = 10\text{ A}$   
 $V_{VOUT\_B} = 0.8\text{ V}$

Figure 79. VOUT\_B Enable Start-up



$V_{VIN} = 12\text{ V}$   
 $I_{OUTB} = 10\text{ A}$   
 $V_{VOUT\_B} = 0.8\text{ V}$

Figure 80. VOUT\_B Enable Shut-down

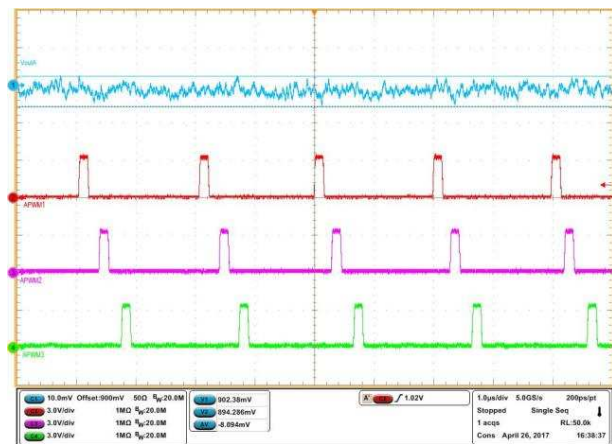

$V_{VIN} = 12\text{ V}$   
 $I_{OUTA} = 30\text{ A}$   
 $V_{VOUT\_A} = 0.9\text{ V}$

Figure 81. Output Voltage (VOUTA) Ripple

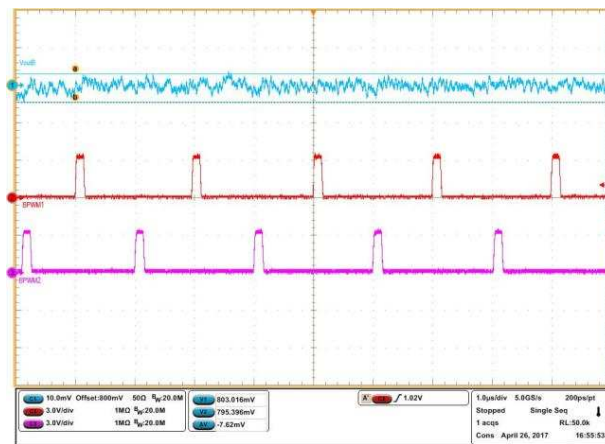

$V_{VIN} = 12\text{ V}$   
 $I_{OUT\_B} = 30\text{ A}$   
 $V_{VOUT\_B} = 0.8\text{ V}$

Figure 82. Output Voltage (VOUTB) Ripple

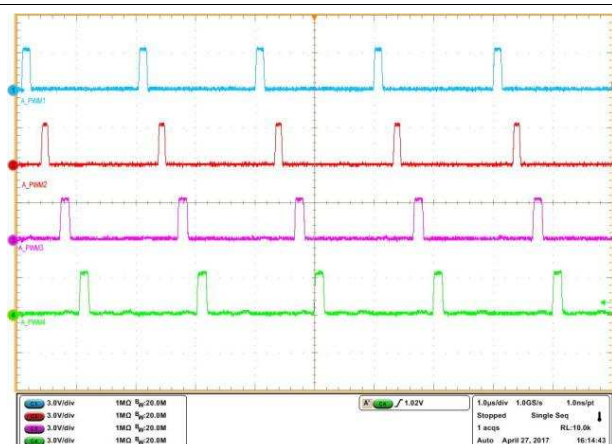

$V_{VIN} = 12\text{ V}$   
 $I_{OUT\_A} = 10\text{ A}$   
 $V_{VOUT\_A} = 0.9\text{ V}$

Figure 83. VOUTA PWM Interleaving (Phases 1-4)

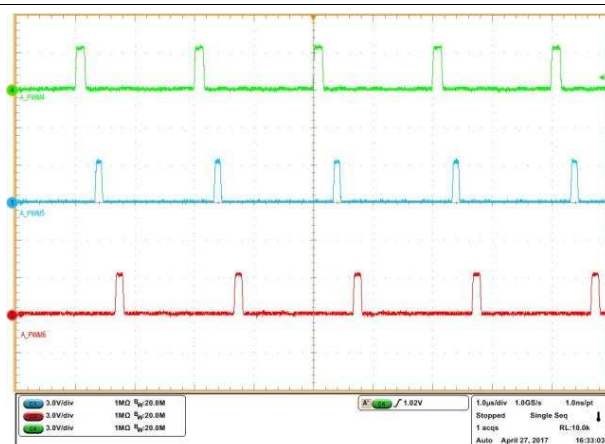

$V_{VIN} = 12\text{ V}$   
 $I_{OUT\_A} = 10\text{ A}$   
 $V_{VOUT\_A} = 0.9\text{ V}$

Figure 84. VOUTA PWM Interleaving (Phases 4-6)

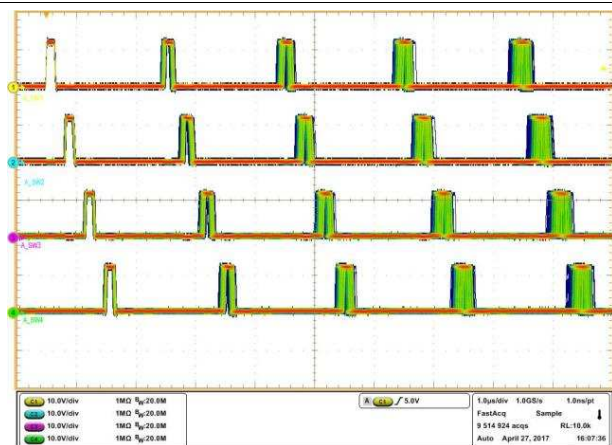

$V_{VIN} = 12\text{ V}$   
 $I_{OUT\_A} = 10\text{ A}$   
 $V_{VOUT\_A} = 0.9\text{ V}$

Figure 85. VOUTA PWM Jitter

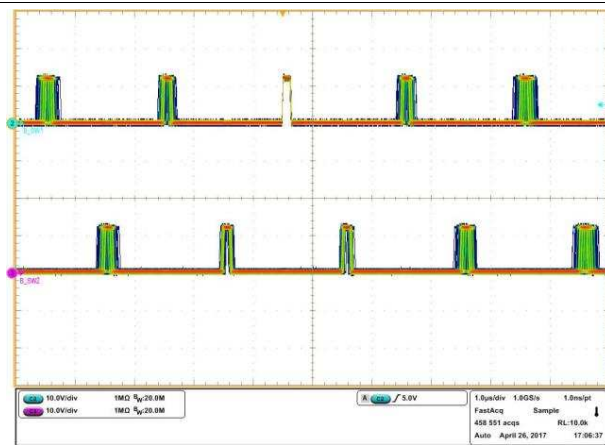

$V_{VIN} = 12\text{ V}$   
 $I_{OUT\_B} = 10\text{ A}$   
 $V_{VOUT\_B} = 0.8\text{ V}$

Figure 86. VOUTB PWM Jitter

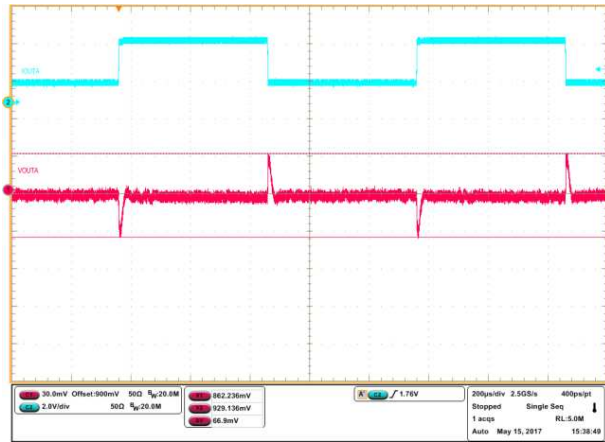

$V_{VIN} = 12\text{ V}$   $V_{VOUT\_A} = 0.9\text{ V}$   
 $I_{OUT\_A}$  from 150 A to 300 A  
 Slew rate = 100 A/µs

Figure 87. VOUTA Transient Response

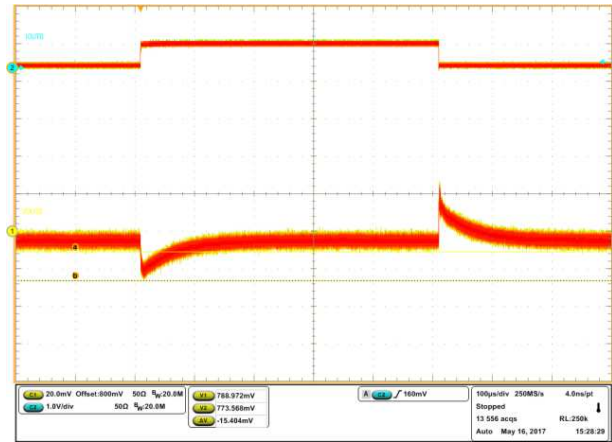

$V_{VIN} = 12\text{ V}$   $V_{VOUT\_B} = 0.8\text{ V}$   
 $I_{OUT\_B}$  from 1 A to 41 A  
 Slew rate = 100 A/µs

Figure 88. VOUTB Transient Response



$V_{VIN} = 12\text{ V}$   $I_{VOUT\_A} = 30\text{ A}$   
 $V_{OUT\_A}$  VID step from 0.8 V to 1.2 V

Figure 89. VOUTA VID-up Change

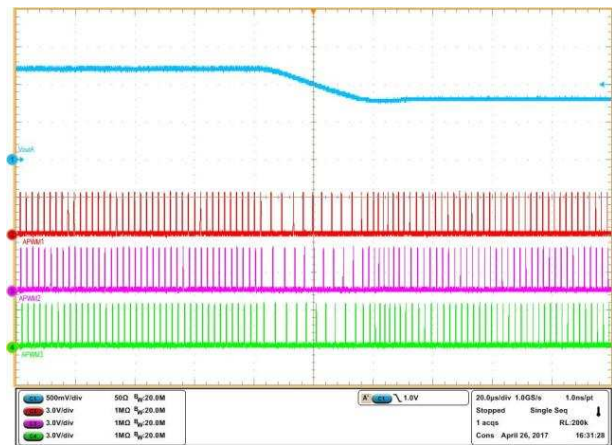

$V_{VIN} = 12\text{ V}$   $I_{VOUT\_A} = 30\text{ A}$   
 $V_{OUT\_A}$  VID step from 1.2 V to 0.8 V

Figure 90. VOUTA VID-down Change



$V_{VIN} = 12\text{ V}$   $I_{VOUT\_B} = 30\text{ A}$   
 $V_{OUT\_B}$  VID step from 0.8 V to 1.2 V

Figure 91. VOUTB VID-up Change

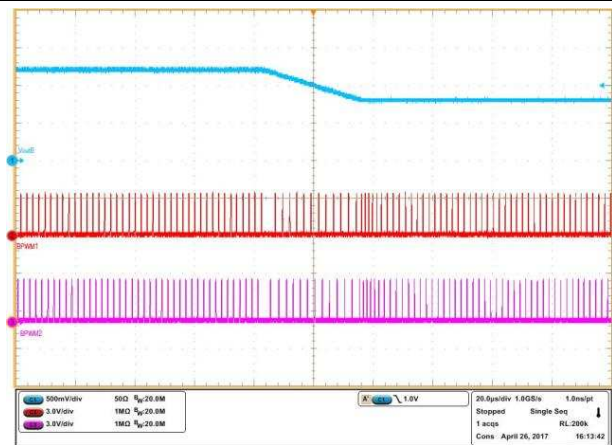

$V_{VIN} = 1.2\text{ V}$   $I_{VOUT\_B} = 30\text{ A}$   
 $V_{OUT\_B}$  VID step from 1.2 V to 0.8 V

Figure 92. VOUTB VID-down Change

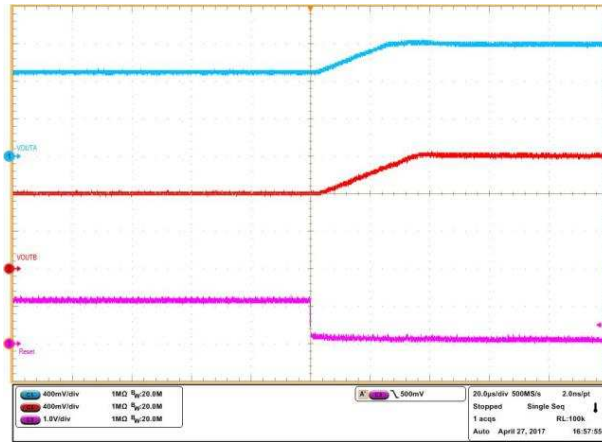

$V_{VIN} = 12\text{ V}$   
 $V_{OUT\_A}$  change from 0.9 V to 1.2 V  
 $V_{OUT\_B}$  change from 0.8 V to 1.2 V

Figure 93. RESET Function

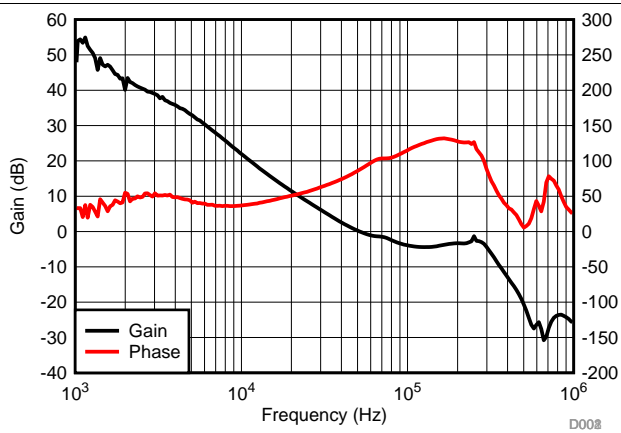

$V_{VIN} = 12\text{ V}$   
 $I_{OUT\_A} = 100\text{ A}$   
 $V_{VOUT\_A} = 900\text{ mV}$

Figure 94. Bode Plot

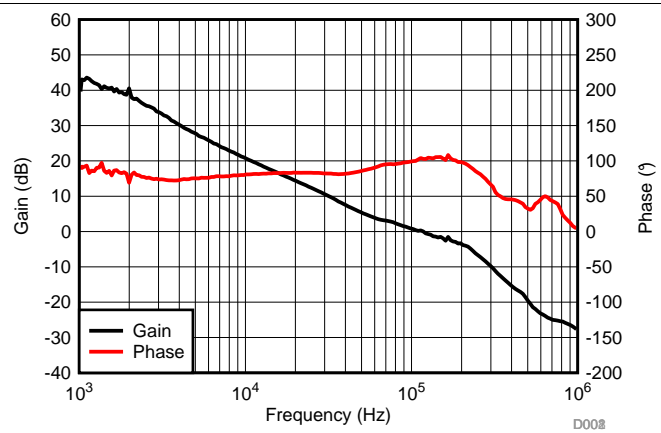

$V_{VIN} = 12\text{ V}$   
 $I_{OUT\_B} = 30\text{ A}$   
 $V_{VOUT\_B} = 800\text{ mV}$

Figure 95. Bode Plot

## 9 Power Supply Recommendations

The TPS53681 device operates from 3.3-V supply at the V3P3 pin (pin 39) and the 12-V supply from the VIN\_CSNIN pin (pin 38). TI recommends the following power-up and power-down sequence in order for the controller to monitor the complete power-up and power-down procedure, fault protection and fault recording. The device provides pre-start up overvoltage protection when the controller and the power stage are enabled before the 12-V input is applied.



图 96. StartUp Waveforms

The recommended power-up sequence is:

1. 3.3 V
2. 5 V
3. PS\_EN
4. 12 V
5. VR\_EN

The recommended power-down sequence is:

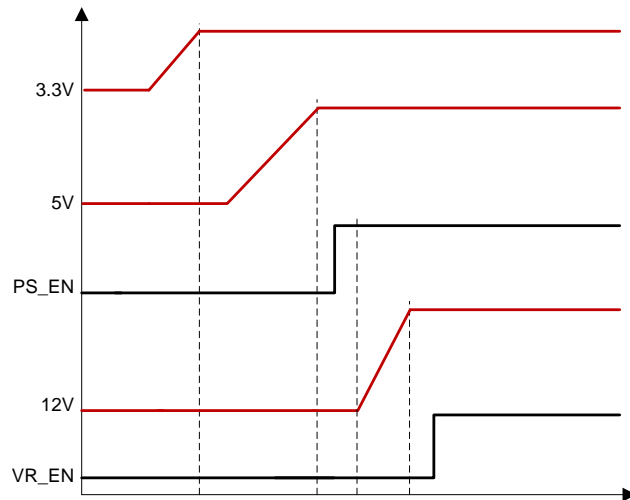
1. VR\_EN
2. 12 V
3. PS\_EN
4. 5 V
5. 3.3 V

## 10 Layout

### 10.1 Layout Guidelines

Contact your local TI representative to get a copy of the schematic and PCB layout guide.

#### 10.1.1 Device Guidelines

The TPS53681 device makes it easy to separate noisy driver interface lines from sensitive interface lines. Because the power stage is external to the device, all gate-drive and switch-node traces must be local to the inductor and power stages.

The device does not require special care in the layout of power chain components, because independent isolated current feedback is provided. Route the phases as symmetrically as possible. Current feedback from each phase must be free of noise and have equal amounts of effective current sense resistance.

---

#### **MOST IMPORTANT LAYOUT SUGGESTION**

**Separate noisy driver interface lines from sensitive analog and PMBus interface lines.**

---

#### 10.1.2 Power Stage Guidelines

- Use the recommended land pattern including the via pattern for the power stage footprint.
- The input voltage bypass capacitors require a minimum of two vias per pad (for both VIN and GND).
- Place additional GND vias along the sides of the device as space allows.
- For multi-phase systems, ensure that the GND pour connects all phases.
- The VOS pin feedback point begins at the inner edge of the inductor output voltage pad.
- Place the VDD and PVDD bypass capacitors directly next to pins on the top layer of the board.

## 10.2 Layout Examples



图 97. Controller Layout Example

Layout Examples (接下页)

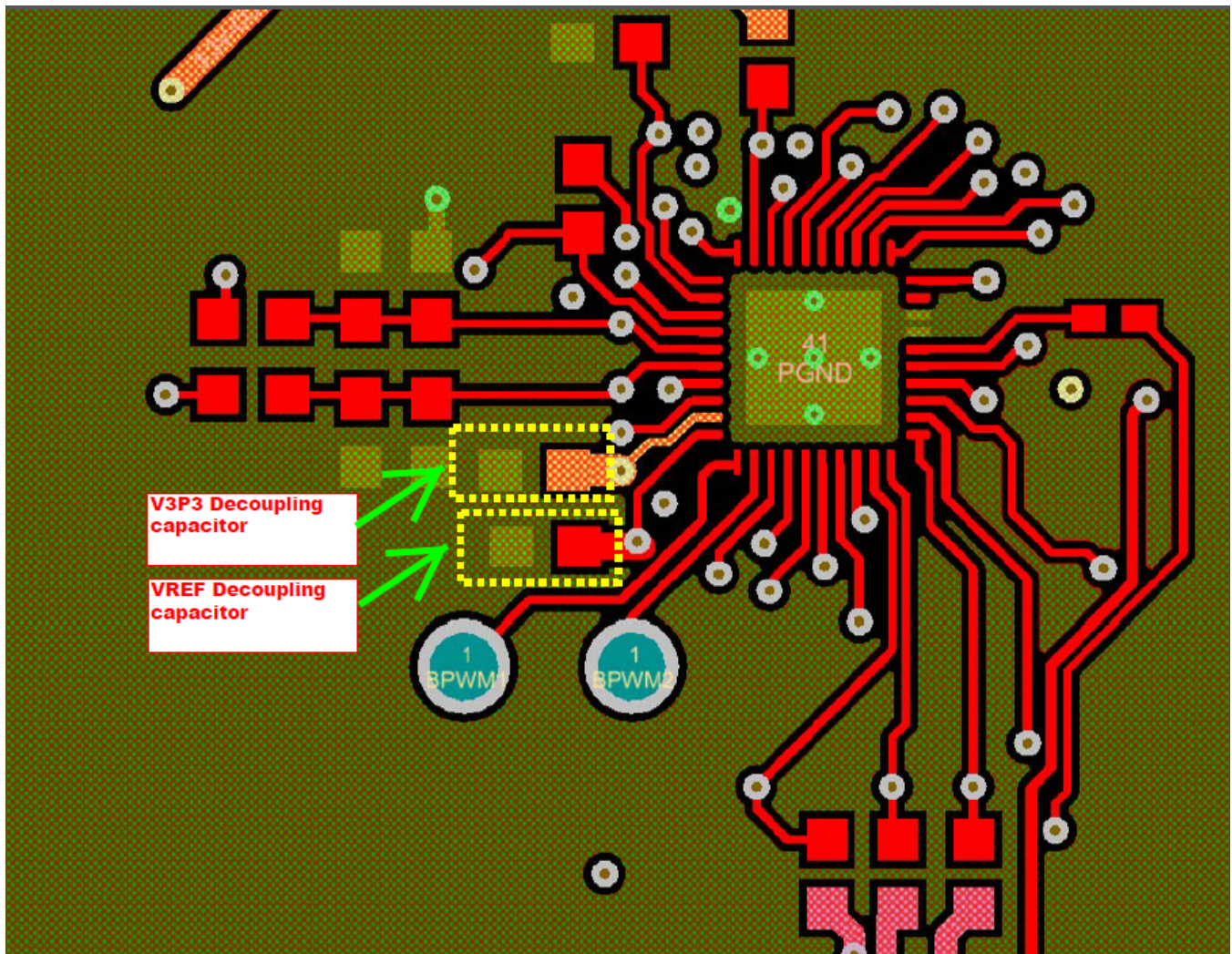

图 98. Power Stage Current Sense Differential Pairs Layout Example

## 11 器件和文档支持

### 11.1 接收文档更新通知

要接收文档更新通知，请导航至 [TI.com.cn](http://TI.com.cn) 上的器件产品文件夹。单击右上角的 [通知我](#) 进行注册，即可每周接收产品信息更改摘要。有关更改的详细信息，请查看任何已修订文档中包含的修订历史记录。

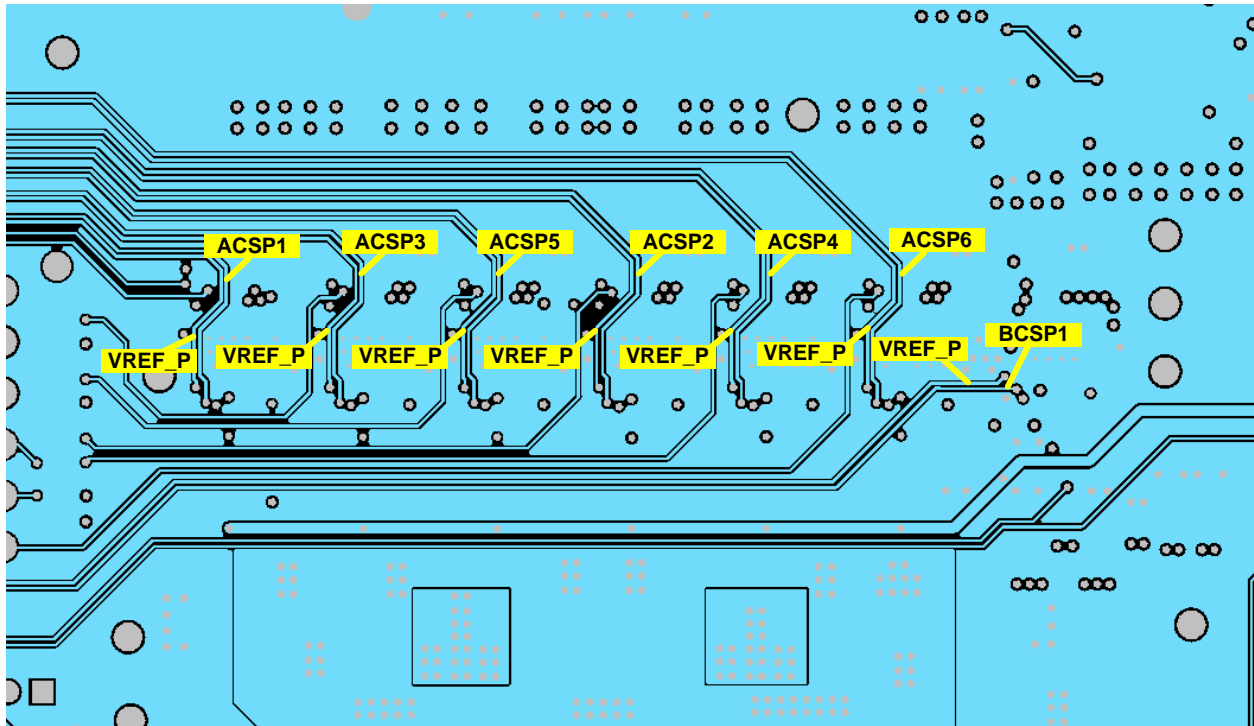
### 11.2 社区资源

下列链接提供到 TI 社区资源的连接。链接的内容由各个分销商“按照原样”提供。这些内容并不构成 TI 技术规范，并且不一定反映 TI 的观点；请参阅 TI 的 [《使用条款》](#)。

**TI E2E™ 在线社区** [TI 的工程师对工程师 \(E2E\) 社区](#)。此社区的创建目的在于促进工程师之间的协作。在 [e2e.ti.com](http://e2e.ti.com) 中，您可以咨询问题、分享知识、拓展思路并与同行工程师一道帮助解决问题。

**设计支持** [TI 参考设计支持](#) 可帮助您快速查找有帮助的 E2E 论坛、设计支持工具以及技术支持的联系信息。

### 11.3 商标

NexFET, AutoBalance, PowerPad, PMBus, D-CAP+, E2E are trademarks of Texas Instruments.

Broadcom is a registered trademark of Broadcom Limited .

Cavium is a registered trademark of Cavium, Inc..

Intel is a registered trademark of Intel Corporation.

PMBus is a trademark of SMIF, Inc..

Xilinx is a registered trademark of Xilinx Inc..

All other trademarks are the property of their respective owners.

### 11.4 静电放电警告



ESD 可能会损坏该集成电路。德州仪器 (TI) 建议通过适当的预防措施处理所有集成电路。如果不遵守正确的处理措施和安装程序，可能会损坏集成电路。

ESD 的损坏小至导致微小的性能降级，大至整个器件故障。精密的集成电路可能更容易受到损坏，这是因为非常细微的参数更改都可能会导致器件与其发布的规格不相符。

### 11.5 术语表

[SLYZ022](#) — *TI 术语表*。

这份术语表列出并解释术语、缩写和定义。

## 12 机械、封装和可订购信息

以下页面包含机械、封装和可订购信息。这些信息是指定器件的最新可用数据。数据如有变更，恕不另行通知，且不会对此文档进行修订。如需获取此数据表的浏览器版本，请查阅左侧的导航栏。

## 重要声明和免责声明



TI 均以“原样”提供技术性数据（包括数据表）、设计资源（包括参考设计）、应用或其他设计建议、网络工具、安全信息和其他资源，不保证其中不含任何瑕疵，且不做任何明示或暗示的担保，包括但不限于对适销性、适合某特定用途或不侵犯任何第三方知识产权的暗示担保。

所述资源可供专业开发人员应用TI 产品进行设计使用。您将对以下行为独自承担全部责任：(1) 针对您的应用选择合适的TI 产品；(2) 设计、验证并测试您的应用；(3) 确保您的应用满足相应标准以及任何其他安全、安保或其他要求。所述资源如有变更，恕不另行通知。TI 对您使用所述资源的授权仅限于开发资源所涉及TI 产品的相关应用。除此之外不得复制或展示所述资源，也不提供其它TI 或任何第三方的知识产权授权许可。如因使用所述资源而产生任何索赔、赔偿、成本、损失及债务等，TI 对此概不负责，并且您须赔偿由此对TI 及其代表造成的损害。

TI 所提供产品均受TI 的销售条款 (<http://www.ti.com.cn/zh-cn/legal/termsofsale.html>) 以及ti.com.cn上或随附TI产品提供的其他可适用条款的约束。TI提供所述资源并不扩展或以其他方式更改TI 针对TI 产品所发布的可适用的担保范围或担保免责声明。

邮寄地址：上海市浦东新区世纪大道 1568 号中建大厦 32 楼，邮政编码：200122  
Copyright © 2019 德州仪器半导体技术（上海）有限公司

**PACKAGING INFORMATION**

Orderable Device	Status (1)	Package Type	Package Drawing	Pins	Package Qty	Eco Plan (2)	Lead finish/ Ball material (6)	MSL Peak Temp (3)	Op Temp (°C)	Device Marking (4/5)	Samples
TPS53681RSBR	ACTIVE	WQFN	RSB	40	3000	RoHS & Green	NIPDAUAG	Level-2-260C-1 YEAR	-40 to 125	TPS 53681	
TPS53681RSBT	ACTIVE	WQFN	RSB	40	250	RoHS & Green	NIPDAUAG	Level-2-260C-1 YEAR	-40 to 125	TPS 53681	

(1) The marketing status values are defined as follows:

**ACTIVE:** Product device recommended for new designs.

**LIFEBUY:** TI has announced that the device will be discontinued, and a lifetime-buy period is in effect.

**NRND:** Not recommended for new designs. Device is in production to support existing customers, but TI does not recommend using this part in a new design.

**PREVIEW:** Device has been announced but is not in production. Samples may or may not be available.

**OBSOLETE:** TI has discontinued the production of the device.

(2) **RoHS:** TI defines "RoHS" to mean semiconductor products that are compliant with the current EU RoHS requirements for all 10 RoHS substances, including the requirement that RoHS substance do not exceed 0.1% by weight in homogeneous materials. Where designed to be soldered at high temperatures, "RoHS" products are suitable for use in specified lead-free processes. TI may reference these types of products as "Pb-Free".

**RoHS Exempt:** TI defines "RoHS Exempt" to mean products that contain lead but are compliant with EU RoHS pursuant to a specific EU RoHS exemption.

**Green:** TI defines "Green" to mean the content of Chlorine (Cl) and Bromine (Br) based flame retardants meet JS709B low halogen requirements of <=1000ppm threshold. Antimony trioxide based flame retardants must also meet the <=1000ppm threshold requirement.

(3) MSL, Peak Temp. - The Moisture Sensitivity Level rating according to the JEDEC industry standard classifications, and peak solder temperature.

(4) There may be additional marking, which relates to the logo, the lot trace code information, or the environmental category on the device.

(5) Multiple Device Markings will be inside parentheses. Only one Device Marking contained in parentheses and separated by a "~" will appear on a device. If a line is indented then it is a continuation of the previous line and the two combined represent the entire Device Marking for that device.

(6) Lead finish/Ball material - Orderable Devices may have multiple material finish options. Finish options are separated by a vertical ruled line. Lead finish/Ball material values may wrap to two lines if the finish value exceeds the maximum column width.

**Important Information and Disclaimer:**The information provided on this page represents TI's knowledge and belief as of the date that it is provided. TI bases its knowledge and belief on information provided by third parties, and makes no representation or warranty as to the accuracy of such information. Efforts are underway to better integrate information from third parties. TI has taken and continues to take reasonable steps to provide representative and accurate information but may not have conducted destructive testing or chemical analysis on incoming materials and chemicals. TI and TI suppliers consider certain information to be proprietary, and thus CAS numbers and other limited information may not be available for release.

In no event shall TI's liability arising out of such information exceed the total purchase price of the TI part(s) at issue in this document sold by TI to Customer on an annual basis.



## TAPE AND REEL INFORMATION

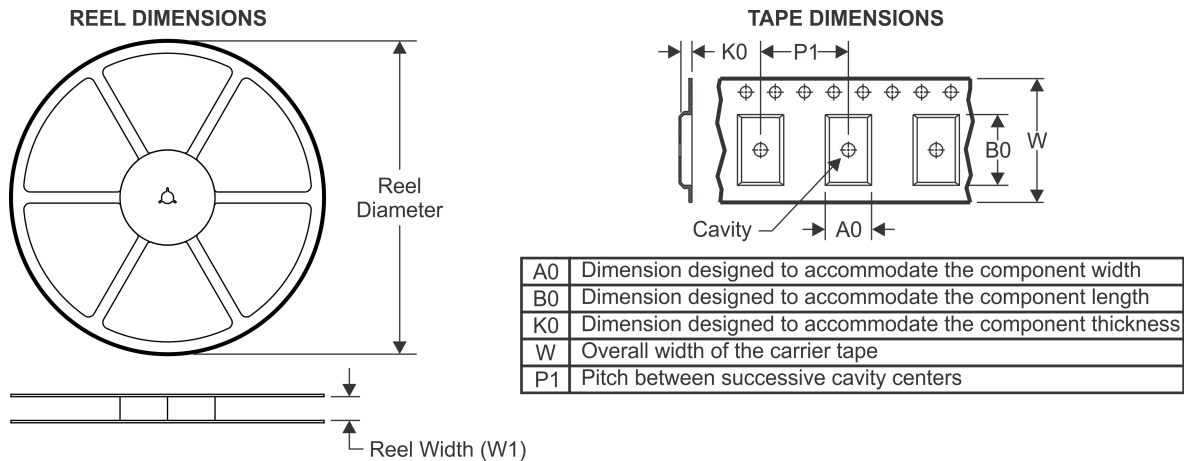

### QUADRANT ASSIGNMENTS FOR PIN 1 ORIENTATION IN TAPE

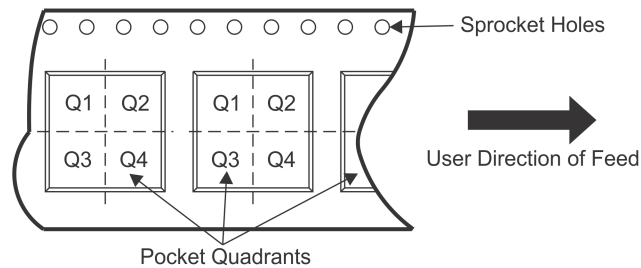

\*All dimensions are nominal

Device	Package Type	Package Drawing	Pins	SPQ	Reel Diameter (mm)	Reel Width W1 (mm)	A0 (mm)	B0 (mm)	K0 (mm)	P1 (mm)	W (mm)	Pin1 Quadrant
TPS53681RSBR	WQFN	RSB	40	3000	330.0	12.4	5.25	5.25	1.1	8.0	12.0	Q2
TPS53681RSBT	WQFN	RSB	40	250	330.0	12.4	5.25	5.25	1.1	8.0	12.0	Q2

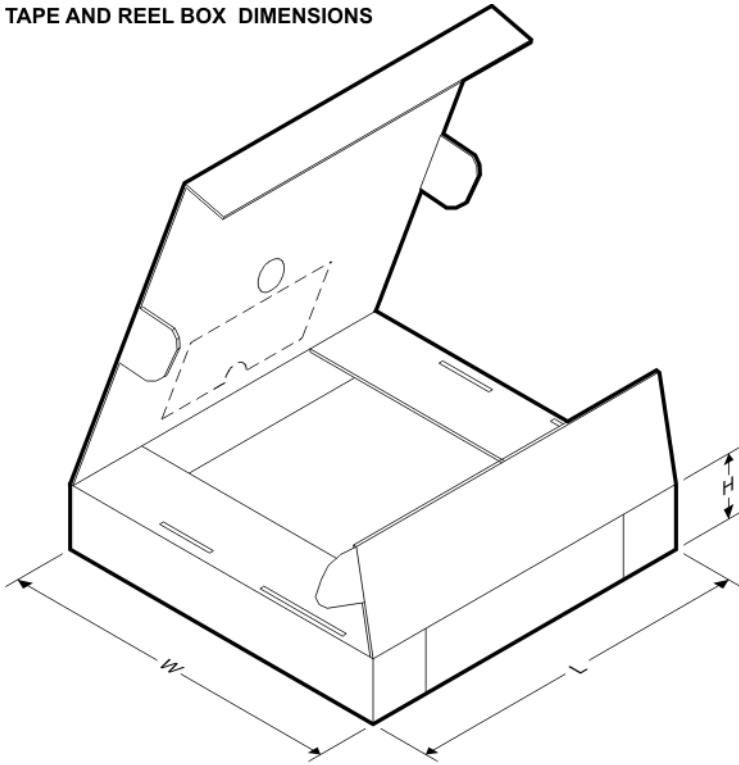
**TAPE AND REEL BOX DIMENSIONS**

\*All dimensions are nominal

Device	Package Type	Package Drawing	Pins	SPQ	Length (mm)	Width (mm)	Height (mm)
TPS53681RSBR	WQFN	RSB	40	3000	338.0	355.0	50.0
TPS53681RSBT	WQFN	RSB	40	250	338.0	355.0	50.0

## GENERIC PACKAGE VIEW

**RSB 40**

**WQFN - 0.8 mm max height**

5 x 5 mm, 0.4 mm pitch

PLASTIC QUAD FLATPACK - NO LEAD

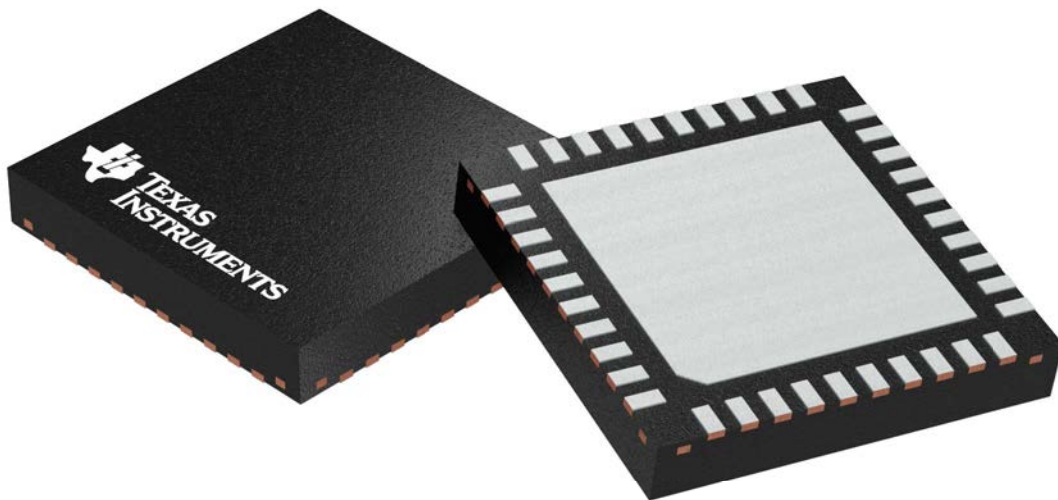

Images above are just a representation of the package family, actual package may vary.  
Refer to the product data sheet for package details.

4207182/D

# RSB0040E

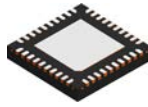

# PACKAGE OUTLINE

## WQFN - 0.8 mm max height

PLASTIC QUAD FLATPACK - NO LEAD

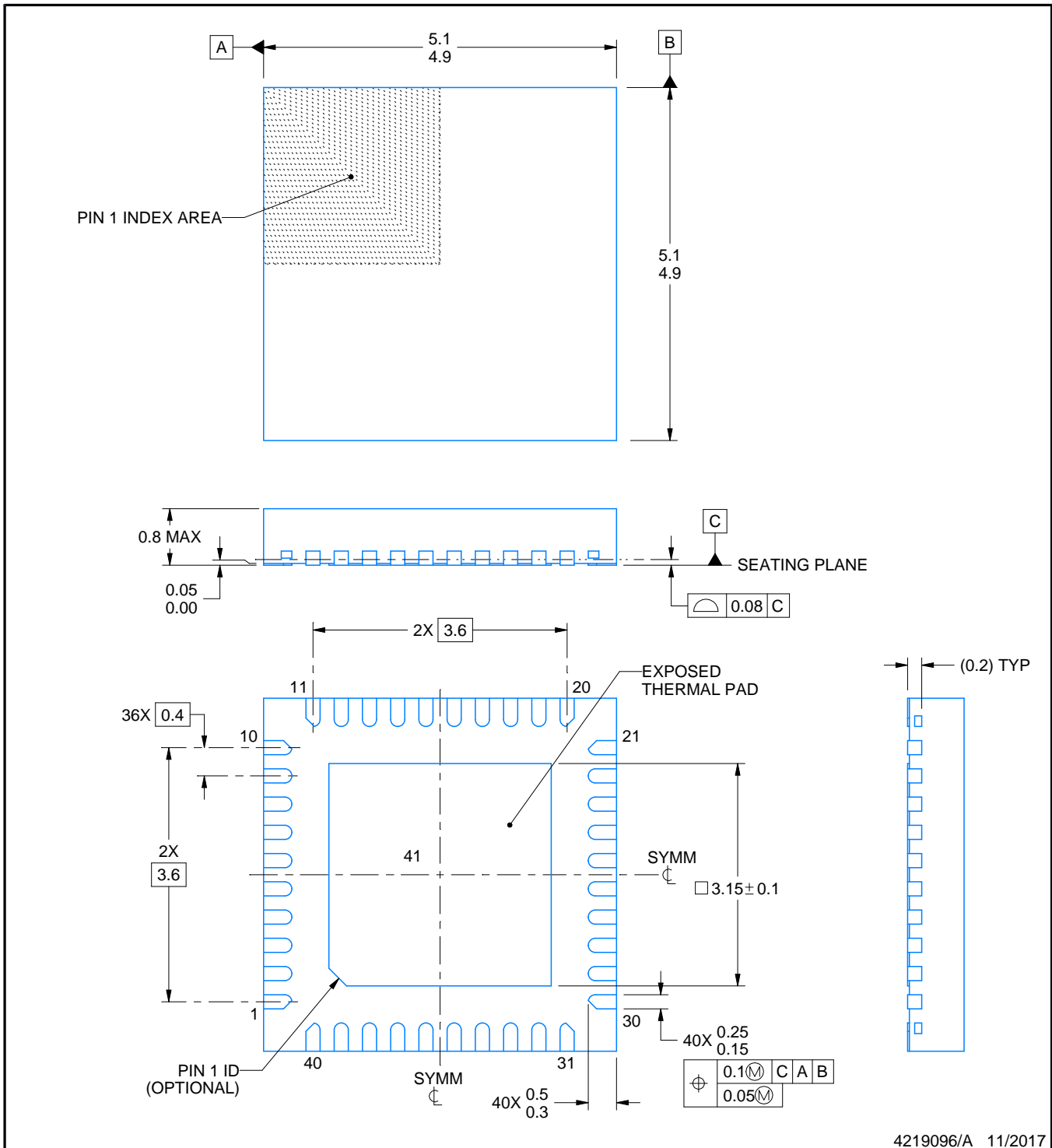

4219096/A 11/2017

**NOTES:**

1. All linear dimensions are in millimeters. Any dimensions in parenthesis are for reference only. Dimensioning and tolerancing per ASME Y14.5M.
2. This drawing is subject to change without notice.
3. The package thermal pad must be soldered to the printed circuit board for thermal and mechanical performance.

# EXAMPLE BOARD LAYOUT

RSB0040E

WQFN - 0.8 mm max height

PLASTIC QUAD FLATPACK - NO LEAD

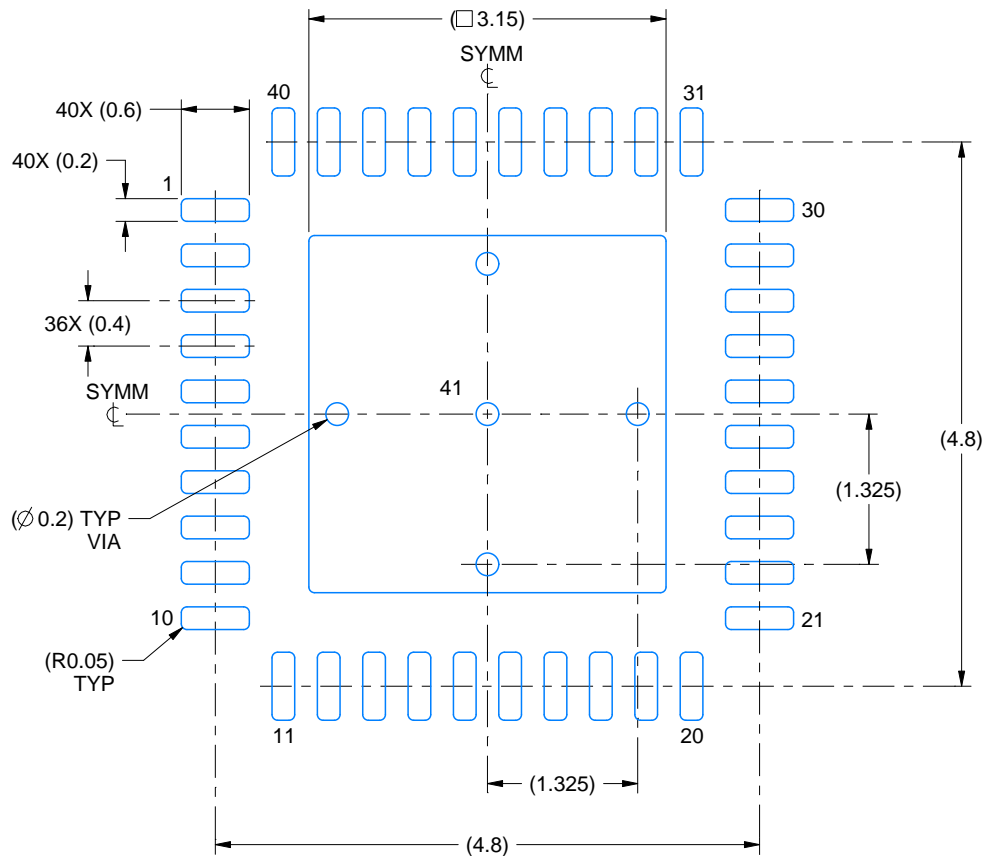

LAND PATTERN EXAMPLE  
EXPOSED METAL SHOWN  
SCALE:15X

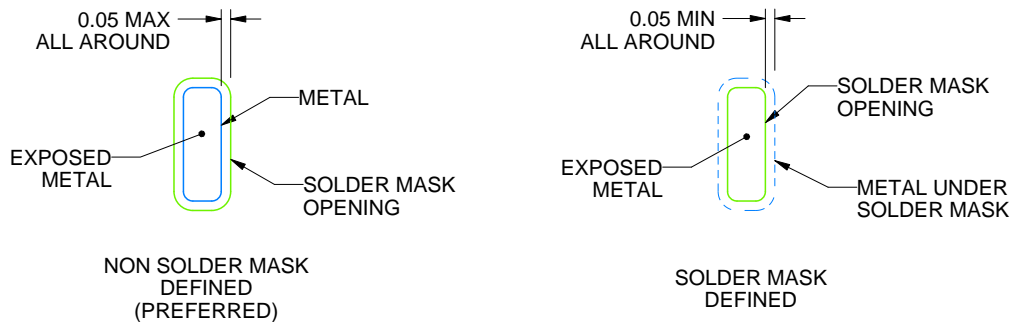

SOLDER MASK DETAILS

4219096/A 11/2017

NOTES: (continued)

4. This package is designed to be soldered to a thermal pad on the board. For more information, see Texas Instruments literature number SLUA271 ([www.ti.com/lit/slua271](http://www.ti.com/lit/slua271)).
5. Vias are optional depending on application, refer to device data sheet. If any vias are implemented, refer to their locations shown on this view. It is recommended that vias under paste be filled, plugged or tented.

# EXAMPLE STENCIL DESIGN

RSB0040E

WQFN - 0.8 mm max height

PLASTIC QUAD FLATPACK - NO LEAD

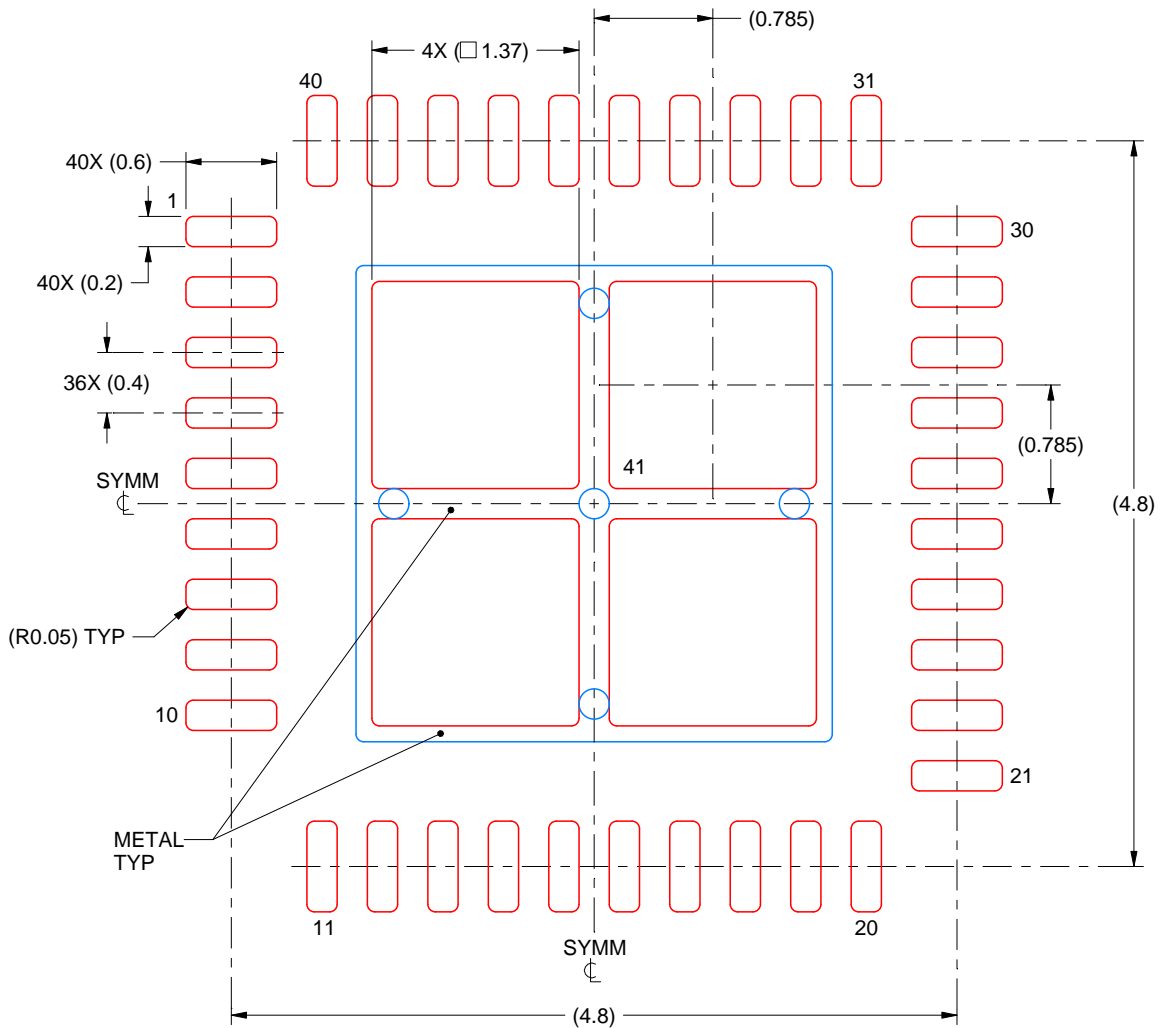

SOLDER PASTE EXAMPLE  
BASED ON 0.1 mm THICK STENCIL

EXPOSED PAD 41  
75% PRINTED SOLDER COVERAGE BY AREA UNDER PACKAGE  
SCALE:20X

4219096/A 11/2017

NOTES: (continued)

6. Laser cutting apertures with trapezoidal walls and rounded corners may offer better paste release. IPC-7525 may have alternate design recommendations.

## 重要声明和免责声明

TI 均以“原样”提供技术性 & 可靠性数据（包括数据表）、设计资源（包括参考设计）、应用或其他设计建议、网络工具、安全信息和其他资源，不保证其中不含任何瑕疵，且不做任何明示或暗示的担保，包括但不限于对适销性、适合某特定用途或不侵犯任何第三方知识产权的暗示担保。

所述资源可供专业开发人员应用 TI 产品进行设计使用。您将对以下行为独自承担全部责任：(1) 针对您的应用选择合适的 TI 产品；(2) 设计、验证并测试您的应用；(3) 确保您的应用满足相应标准以及任何其他安全、安保或其他要求。所述资源如有变更，恕不另行通知。TI 对您使用所述资源的授权仅限于开发资源所涉及 TI 产品的相关应用。除此之外不得复制或展示所述资源，也不提供其它 TI 或任何第三方的知识产权授权许可。如因使用所述资源而产生任何索赔、赔偿、成本、损失及债务等，TI 对此概不负责，并且您须赔偿由此对 TI 及其代表造成的损害。

TI 所提供产品均受 TI 的销售条款 (<http://www.ti.com.cn/zh-cn/legal/termsofsale.html>) 以及 [ti.com.cn](http://www.ti.com.cn) 上或随附 TI 产品提供的其他可适用条款的约束。TI 提供所述资源并不扩展或以其他方式更改 TI 针对 TI 产品所发布的可适用的担保范围或担保免责声明。

邮寄地址：上海市浦东新区世纪大道 1568 号中建大厦 32 楼，邮政编码：200122  
Copyright © 2020 德州仪器半导体技术（上海）有限公司