

# TPA0253

## 1-W MONO AUDIO POWER AMPLIFIER WITH HEADPHONE DRIVE

SLOS280D – JANUARY 2000 – REVISED NOVEMBER 2002

- Ideal for Notebook Computers, PDAs, and Other Small Portable Audio Devices
- 1 W Into 8-Ω From 5-V Supply
- 0.3 W Into 8-Ω From 3-V Supply
- Stereo Head Phone Drive
- Mono (BTL) Signal Created by Summing Left and Right Signals Internally
- Wide Power Supply Compatibility  
2.5 V to 5.5 V
- Low Supply Current
  - 3.2 mA Typical at 5 V
  - 2.7 mA Typical at 3 V
- Shutdown Control . . . 1 μA Typical
- Shutdown Pin Is TTL Compatible
- –40°C to 85°C Operating Temperature Range
- Space-Saving, Thermally-Enhanced MSOP Packaging

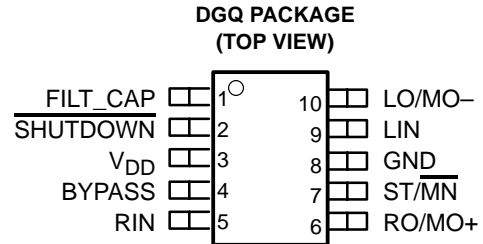

### description

The TPA0253 is a 1-W mono bridge-tied-load (BTL) amplifier designed to drive speakers with as low as 8-Ω impedance. The mono signal is created by summing left and right inputs internally. The amplifier can be reconfigured on the fly to drive two stereo single-ended (SE) signals into headphones. This makes the device ideal for use in small notebook computers, PDAs, digital personal audio players, anyplace a mono speaker and stereo headphones are required. From a 5-V supply, the TPA0253 can deliver 1-W of power into an 8-Ω speaker.

The gain of the input stage is set by the user-selected input resistor and a 50-kΩ internal feedback resistor ( $A_V = -R_F/R_I$ ). The power stage is internally configured with a gain of –1.25 V/V in SE mode, and –2.5 V/V in BTL mode. Thus, the overall gain of the amplifier is 62.5 kΩ/R<sub>I</sub> in SE mode and 125 kΩ/R<sub>I</sub> in BTL mode. The input terminals are high-impedance CMOS inputs, and can be used as summing nodes.

The TPA0253 is available in the 10-pin thermally-enhanced MSOP package (DGQ) and operates over an ambient temperature range of –40°C to 85°C.

#### AVAILABLE OPTIONS

T <sub>A</sub>	PACKAGED DEVICES	MSOP SYMBOLIZATION
	MSOP† (DGQ)	
–40°C to 85°C	TPA0253DGQ	AEL

† The DGQ package are available taped and reeled. To order a taped and reeled part, add the suffix R to the part number (e.g., TPA0253DGQR).



Please be aware that an important notice concerning availability, standard warranty, and use in critical applications of Texas Instruments semiconductor products and disclaimers thereto appears at the end of this data sheet.

PRODUCTION DATA information is current as of publication date. Products conform to specifications per the terms of Texas Instruments standard warranty. Production processing does not necessarily include testing of all parameters.

**TEXAS  
INSTRUMENTS**

POST OFFICE BOX 655303 • DALLAS, TEXAS 75265

Copyright © 2002, Texas Instruments Incorporated

# TPA0253 1-W MONO AUDIO POWER AMPLIFIER WITH HEADPHONE DRIVE

SLOS280D – JANUARY 2000 – REVISED NOVEMBER 2002

## schematic

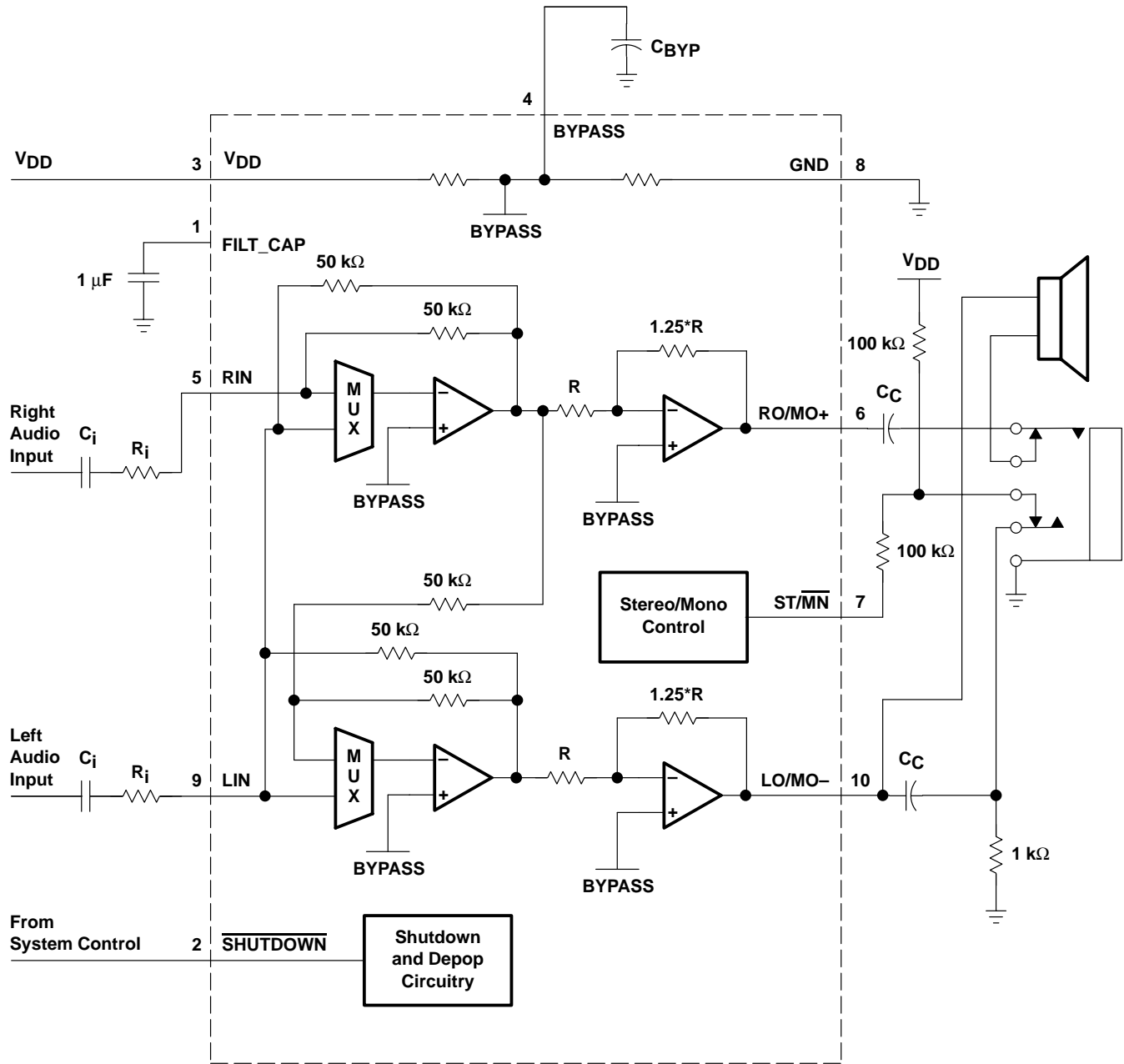

### Terminal Functions

TERMINAL NAME	NO.	I/O	DESCRIPTION
BYPASS	4	I	Midrail bias voltage
FILT_CAP	1		Terminal used to filter power supply
GND	8		Ground terminal
LIN	9	I	Left-channel input terminal
LO/MO-	10	O	Left-output in SE mode and mono negative output in BTL mode.
RIN	5	I	Right-channel input terminal
RO/MO+	6	O	Right-output in SE mode and mono positive output in BTL mode
SHUTDOWN	2	I	TTL-compatible shutdown terminal
ST/MN	7	I	Selects between stereo and mono mode. When held high, the amplifier is in SE stereo mode; while held low, the amplifier is in BTL mono mode.
V <sub>DD</sub>	3	I	Positive power supply

### absolute maximum ratings over operating free-air temperature range (unless otherwise noted)†

Supply voltage, V <sub>DD</sub>	6 V
Input voltage range, V <sub>I</sub>	-0.3 V to V <sub>DD</sub> +0.3 V
Continuous total power dissipation	internally limited (see Dissipation Rating Table)
Operating free-air temperature range, T <sub>A</sub> (see Table 3)	-40°C to 85°C
Operating junction temperature range, T <sub>J</sub>	-40°C to 150°C
Storage temperature range, T <sub>stg</sub>	-65°C to 150°C
Lead temperature 1,6 mm (1/16 inch) from case for 10 seconds	260°C

† Stresses beyond those listed under “absolute maximum ratings” may cause permanent damage to the device. These are stress ratings only, and functional operation of the device at these or any other conditions beyond those indicated under “recommended operating conditions” is not implied. Exposure to absolute-maximum-rated conditions for extended periods may affect device reliability.

**DISSIPATION RATING TABLE**

PACKAGE	T <sub>A</sub> ≤ 25°C	DERATING FACTOR	T <sub>A</sub> = 70°C	T <sub>A</sub> = 85°C
DGQ	2.14 W <sup>§</sup>	17.1 mW/°C	1.37 W	1.11 W

‡ Please see the Texas Instruments document, *PowerPAD Thermally Enhanced Package Application Report* (SLMA002), for more information on the PowerPAD™ package. The thermal data was measured on a PCB layout based on the information in the section entitled *Texas Instruments Recommended Board for PowerPAD* on page 33 of that document.

**TPA0253**  
**1-W MONO AUDIO POWER AMPLIFIER**  
**WITH HEADPHONE DRIVE**

SLOS280D – JANUARY 2000 – REVISED NOVEMBER 2002

**recommended operating conditions**

			MIN	MAX	UNIT
Supply voltage, $V_{DD}$			2.5	5.5	V
High-level input voltage, $V_{IH}$	ST/MN	$V_{DD} = 3\text{ V}$	2.7		V
		$V_{DD} = 5\text{ V}$	4.5		
	SHUTDOWN		2		
Low-level input voltage, $V_{IL}$	ST/MN	$V_{DD} = 3\text{ V}$		1.65	V
		$V_{DD} = 5\text{ V}$		2.75	
	SHUTDOWN			0.8	
Operating free-air temperature, $T_A$			-40	85	°C

**electrical characteristics at specified free-air temperature,  $V_{DD} = 3\text{ V}$ ,  $T_A = 25^\circ\text{C}$  (unless otherwise noted)**

PARAMETER		TEST CONDITIONS	MIN	TYP	MAX	UNIT
$ V_{OO} $	Output offset voltage (measured differentially)	$R_L = 4\ \Omega$ , ST/MN = 0 V, SHUTDOWN = 2 V			30	mV
PSRR	Power supply rejection ratio	$V_{DD} = 2.9\text{ V to } 3.1\text{ V}$ , BTL mode		65		dB
$ I_{IH} $	High-level input current	SHUTDOWN, $V_{DD} = 3.3\text{ V}$ , $V_I = V_{DD}$			1	$\mu\text{A}$
		ST/MN, $V_{DD} = 3.3\text{ V}$ , $V_I = V_{DD}$			1	
$ I_{IL} $	Low-level input current	SHUTDOWN, $V_{DD} = 3.3\text{ V}$ , $V_I = 0\text{ V}$			1	$\mu\text{A}$
		ST/MN, $V_{DD} = 3.3\text{ V}$ , $V_I = 0\text{ V}$			1	
$Z_I$	Input impedance			50		k $\Omega$
$I_{DD}$	Supply current	$V_{DD} = 2.5\text{ V}$ , SHUTDOWN = 2 V		2.7	4	mA
$I_{DD(SD)}$	Supply current, shutdown mode	SHUTDOWN = 0 V		1	10	$\mu\text{A}$
$R_F$	Feedback resistor	$V_{DD} = 2.5\text{ V}$ , $R_L = 4\ \Omega$ , ST/MN = 1.375 V, SHUTDOWN = 2 V	47	50	57	k $\Omega$

**operating characteristics,  $V_{DD} = 3\text{ V}$ ,  $T_A = 25^\circ\text{C}$ ,  $R_L = 8\ \Omega$ ,  $f = 1\text{ kHz}$  (unless otherwise noted)**

PARAMETER		TEST CONDITIONS	MIN	TYP	MAX	UNIT
$P_O$	Output power, see Note 1	THD = 0.1%, BTL mode, Gain = 14 dB		300		mW
		THD = 0.1%, SE mode, $R_L = 32\ \Omega$ , Gain = 1.9 dB		30		
THD + N	Total harmonic distortion plus noise	$P_O = 250\text{ mW}$ , $f = 20\text{ Hz to } 20\text{ kHz}$		0.2%		
BOM	Maximum output power bandwidth	Gain = 1.9 dB, THD = 2%		20		kHz
	Supple ripple rejection ratio	$f = 1\text{ kHz}$ , $C_{(BYP)} = 0.47\ \mu\text{F}$	BTL mode	46		dB
			SE mode	68		
$V_n$	Noise output voltage	$C_{(BYP)} = 0.47\ \mu\text{F}$ , $f = 20\text{ Hz to } 20\text{ kHz}$	BTL mode	83		$\mu\text{V}_{RMS}$
			SE mode	33		

NOTE 1: Output power is measured at the output terminals of the device at  $f = 1\text{ kHz}$ .



**TPA0253**  
**1-W MONO AUDIO POWER AMPLIFIER**  
**WITH HEADPHONE DRIVE**

SLOS280D – JANUARY 2000 – REVISED NOVEMBER 2002

**electrical characteristics at specified free-air temperature,  $V_{DD} = 5\text{ V}$ ,  $T_A = 25^\circ\text{C}$  (unless otherwise noted)**

PARAMETER		TEST CONDITIONS	MIN	TYP	MAX	UNIT
$ V_{OO} $	Output offset voltage (measured differentially)	$R_L = 4\ \Omega$ , $ST/MN = 0\text{ V}$ , $SHUTDOWN = 2\text{ V}$			30	mV
PSRR	Power supply rejection ratio	$V_{DD} = 4.9\text{ V}$ to $5.1\text{ V}$ , BTL mode		62		dB
$ I_{IH} $	High-level input current	$SHUTDOWN$ , $V_{DD} = 5.5\text{ V}$ , $V_I = V_{DD}$			1	$\mu\text{A}$
		$ST/MN$ , $V_{DD} = 5.5\text{ V}$ , $V_I = V_{DD}$			1	
$ I_{IL} $	Low-level input current	$SHUTDOWN$ , $V_{DD} = 5.5\text{ V}$ , $V_I = 0\text{ V}$			1	$\mu\text{A}$
		$ST/MN$ , $V_{DD} = 5.5\text{ V}$ , $V_I = 0\text{ V}$			1	
$Z_I$	Input impedance			50		k $\Omega$
$I_{DD}$	Supply current	$SHUTDOWN = 2\text{ V}$		3.2	4.8	mA
$I_{DD(SD)}$	Supply current, shutdown mode	$SHUTDOWN = 0\text{ V}$		1	10	$\mu\text{A}$

**operating characteristics,  $V_{DD} = 5\text{ V}$ ,  $T_A = 25^\circ\text{C}$ ,  $R_L = 8\ \Omega$ ,  $f = 1\text{ kHz}$  (unless otherwise noted)**

PARAMETER		TEST CONDITIONS		MIN	TYP	MAX	UNIT
$P_O$	Output power (see Note 1)	THD = 0.1%,	BTL mode		1		W
		THD = 0.1%,	SE mode, $R_L = 32\ \Omega$		85		mW
THD + N	Total harmonic distortion plus noise	$P_O = 1\text{ W}$ ,	$f = 20\text{ Hz}$ to $20\text{ kHz}$		0.33%		
BOM	Maximum output power bandwidth	Gain = 8 dB,	THD = 2%		20		kHz
	Supply ripple rejection ratio	$f = 1\text{ kHz}$ ,	$C_{(BYP)} = 0.47\ \mu\text{F}$	BTL mode		46	dB
				SE mode		60	
$V_n$	Noise output voltage	$C_{(BYP)} = 0.47\ \mu\text{F}$ ,	$f = 20\text{ Hz}$ to $20\text{ kHz}$	BTL mode		85	$\mu\text{VRMS}$
				SE mode		34	

NOTE 1: Output power is measured at the output terminals of the device at  $f = 1\text{ kHz}$ .

## PACKAGING INFORMATION

Orderable Device	Status (1)	Package Type	Package Drawing	Pins	Package Qty	Eco Plan (2)	Lead finish/ Ball material (6)	MSL Peak Temp (3)	Op Temp (°C)	Device Marking (4/5)	Samples
TPA0253DGQ	ACTIVE	HVSSOP	DGQ	10	80	RoHS & Green	NIPDAU	Level-1-260C-UNLIM	-40 to 85	AEL	<a href="#">Samples</a>
TPA0253DGQG4	ACTIVE	HVSSOP	DGQ	10	80	RoHS & Green	NIPDAU	Level-1-260C-UNLIM	-40 to 85	AEL	<a href="#">Samples</a>
TPA0253DGQR	ACTIVE	HVSSOP	DGQ	10	2500	RoHS & Green	NIPDAU	Level-1-260C-UNLIM	-40 to 85	AEL	<a href="#">Samples</a>
TPA0253DGQRG4	ACTIVE	HVSSOP	DGQ	10	2500	RoHS & Green	NIPDAU	Level-1-260C-UNLIM	-40 to 85	AEL	<a href="#">Samples</a>

(1) The marketing status values are defined as follows:

**ACTIVE:** Product device recommended for new designs.

**LIFEBUY:** TI has announced that the device will be discontinued, and a lifetime-buy period is in effect.

**NRND:** Not recommended for new designs. Device is in production to support existing customers, but TI does not recommend using this part in a new design.

**PREVIEW:** Device has been announced but is not in production. Samples may or may not be available.

**OBSELETE:** TI has discontinued the production of the device.

(2) **RoHS:** TI defines "RoHS" to mean semiconductor products that are compliant with the current EU RoHS requirements for all 10 RoHS substances, including the requirement that RoHS substance do not exceed 0.1% by weight in homogeneous materials. Where designed to be soldered at high temperatures, "RoHS" products are suitable for use in specified lead-free processes. TI may reference these types of products as "Pb-Free".

**RoHS Exempt:** TI defines "RoHS Exempt" to mean products that contain lead but are compliant with EU RoHS pursuant to a specific EU RoHS exemption.

**Green:** TI defines "Green" to mean the content of Chlorine (Cl) and Bromine (Br) based flame retardants meet JS709B low halogen requirements of <=1000ppm threshold. Antimony trioxide based flame retardants must also meet the <=1000ppm threshold requirement.

(3) MSL, Peak Temp. - The Moisture Sensitivity Level rating according to the JEDEC industry standard classifications, and peak solder temperature.

(4) There may be additional marking, which relates to the logo, the lot trace code information, or the environmental category on the device.

(5) Multiple Device Markings will be inside parentheses. Only one Device Marking contained in parentheses and separated by a "-" will appear on a device. If a line is indented then it is a continuation of the previous line and the two combined represent the entire Device Marking for that device.

(6) Lead finish/Ball material - Orderable Devices may have multiple material finish options. Finish options are separated by a vertical ruled line. Lead finish/Ball material values may wrap to two lines if the finish value exceeds the maximum column width.

**Important Information and Disclaimer:**The information provided on this page represents TI's knowledge and belief as of the date that it is provided. TI bases its knowledge and belief on information provided by third parties, and makes no representation or warranty as to the accuracy of such information. Efforts are underway to better integrate information from third parties. TI has taken and

continues to take reasonable steps to provide representative and accurate information but may not have conducted destructive testing or chemical analysis on incoming materials and chemicals. TI and TI suppliers consider certain information to be proprietary, and thus CAS numbers and other limited information may not be available for release.

In no event shall TI's liability arising out of such information exceed the total purchase price of the TI part(s) at issue in this document sold by TI to Customer on an annual basis.

## TAPE AND REEL INFORMATION



### QUADRANT ASSIGNMENTS FOR PIN 1 ORIENTATION IN TAPE



\*All dimensions are nominal

Device	Package Type	Package Drawing	Pins	SPQ	Reel Diameter (mm)	Reel Width W1 (mm)	A0 (mm)	B0 (mm)	K0 (mm)	P1 (mm)	W (mm)	Pin1 Quadrant
TPA0253DGQR	HVSSOP	DGQ	10	2500	330.0	12.4	5.3	3.4	1.4	8.0	12.0	Q1

TAPE AND REEL BOX DIMENSIONS



\*All dimensions are nominal

Device	Package Type	Package Drawing	Pins	SPQ	Length (mm)	Width (mm)	Height (mm)
TPA0253DGQR	HVSSOP	DGQ	10	2500	358.0	335.0	35.0

## GENERIC PACKAGE VIEW

**DGQ 10**

**PowerPAD™ HVSSOP - 1.1 mm max height**

3 x 3, 0.5 mm pitch

PLASTIC SMALL OUTLINE

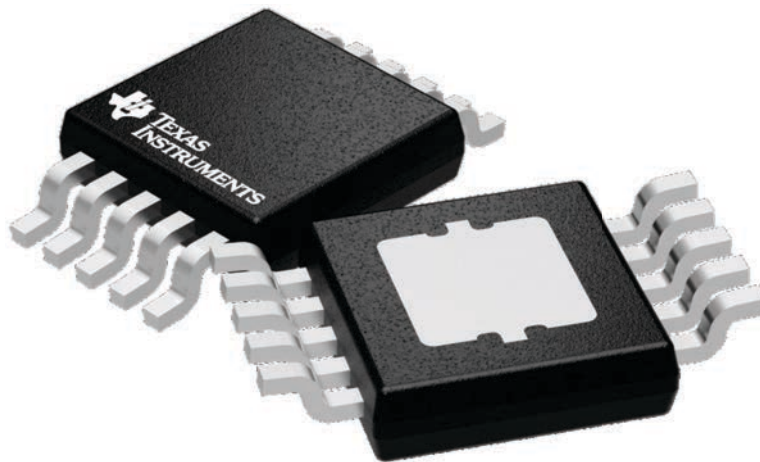

Images above are just a representation of the package family, actual package may vary.  
Refer to the product data sheet for package details.

4224775/A

# DGQ0010D

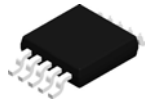

# PACKAGE OUTLINE

PowerPAD™ - 1.1 mm max height

PLASTIC SMALL OUTLINE

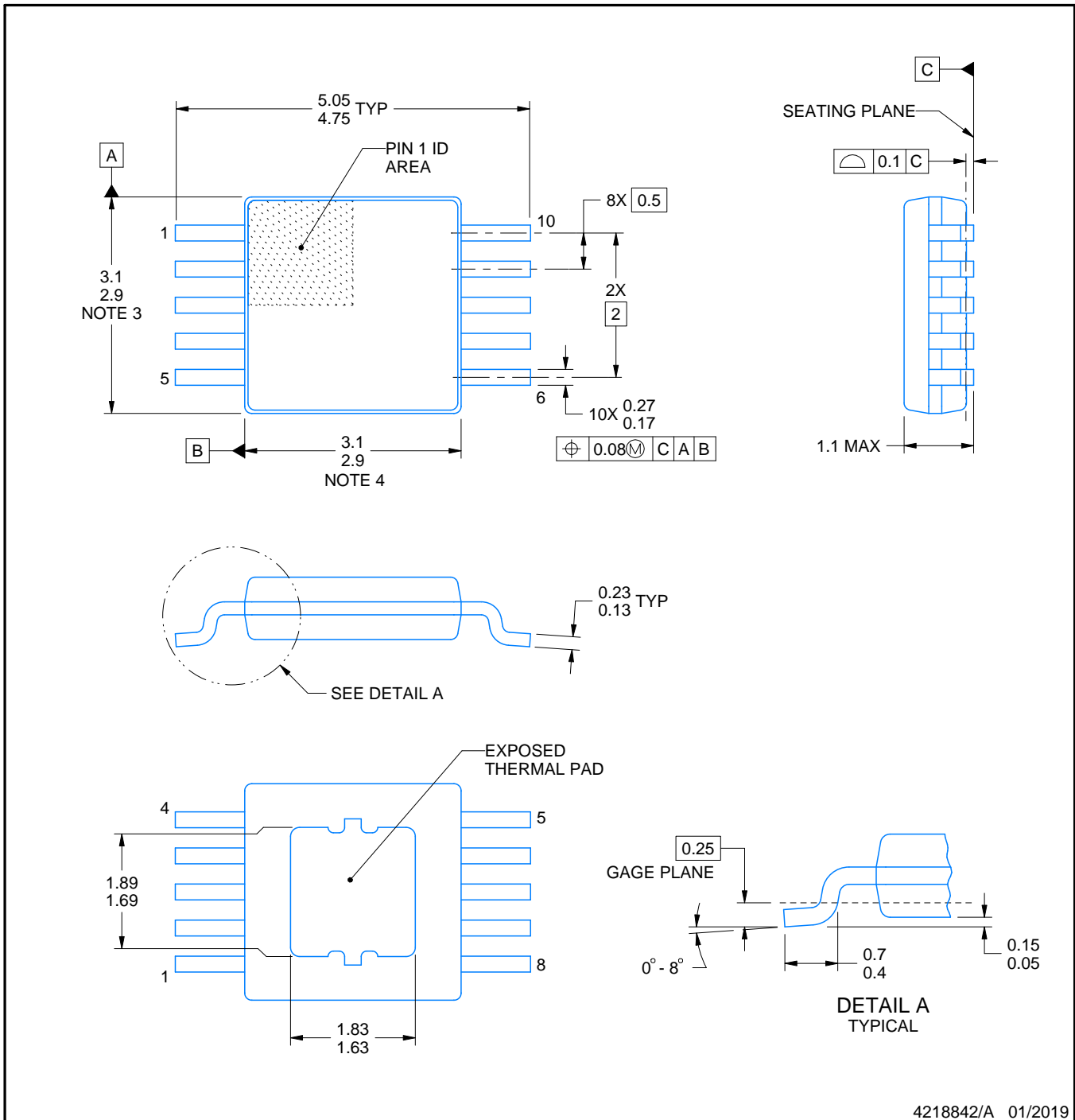

4218842/A 01/2019

PowerPAD is a trademark of Texas Instruments.

## NOTES:

1. All linear dimensions are in millimeters. Any dimensions in parenthesis are for reference only. Dimensioning and tolerancing per ASME Y14.5M.
2. This drawing is subject to change without notice.
3. This dimension does not include mold flash, protrusions, or gate burrs. Mold flash, protrusions, or gate burrs shall not exceed 0.15 mm per side.
4. This dimension does not include interlead flash. Interlead flash shall not exceed 0.25 mm per side.
5. Reference JEDEC registration MO-187, variation BA-T.

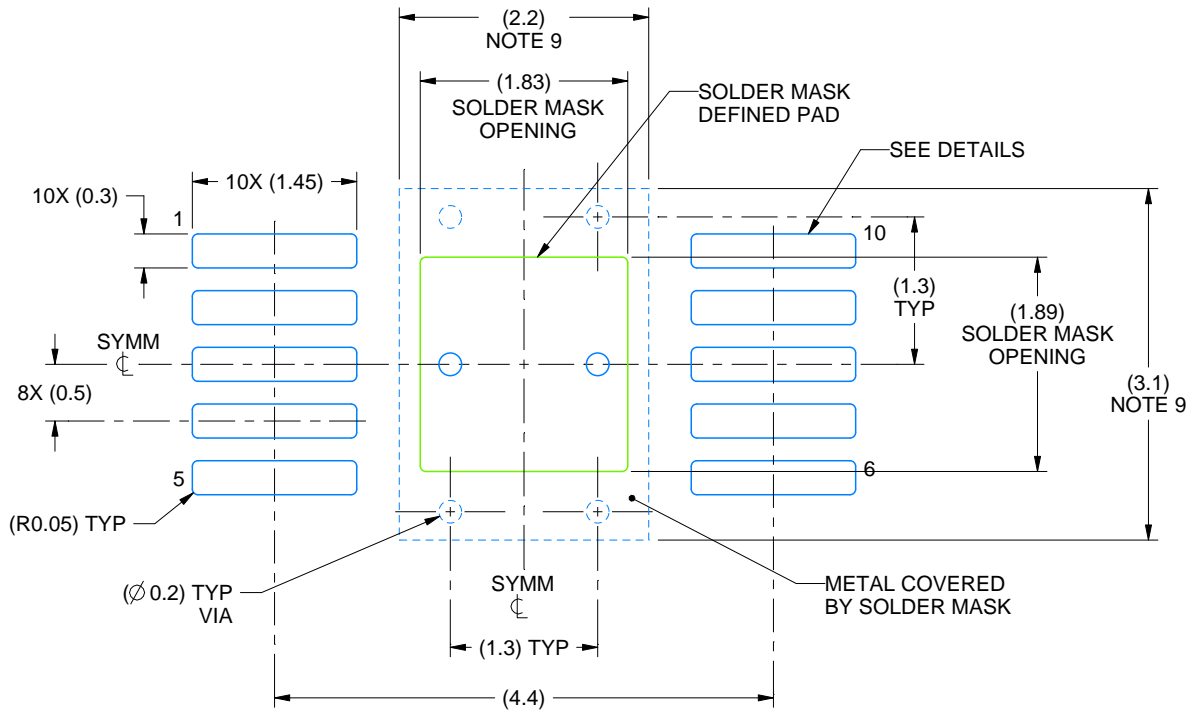

LAND PATTERN EXAMPLE  
SCALE:15X

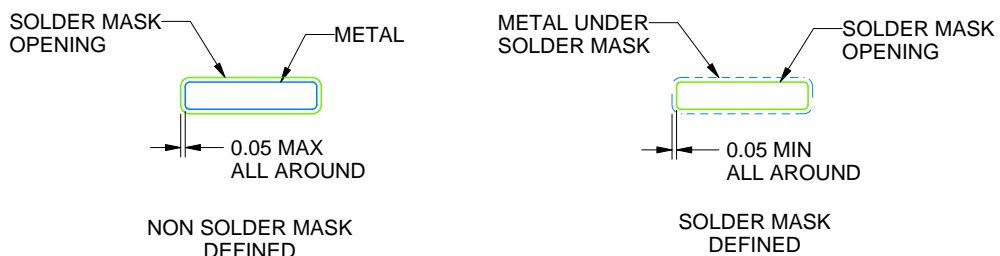

SOLDER MASK DETAILS

4218842/A 01/2019

NOTES: (continued)

6. Publication IPC-7351 may have alternate designs.
7. Solder mask tolerances between and around signal pads can vary based on board fabrication site.
8. This package is designed to be soldered to a thermal pad on the board. For more information, see Texas Instruments literature numbers SLMA002 ([www.ti.com/lit/slma002](http://www.ti.com/lit/slma002)) and SLMA004 ([www.ti.com/lit/slma004](http://www.ti.com/lit/slma004)).
9. Size of metal pad may vary due to creepage requirement.

# EXAMPLE STENCIL DESIGN

DGQ0010D

PowerPAD™ - 1.1 mm max height

PLASTIC SMALL OUTLINE

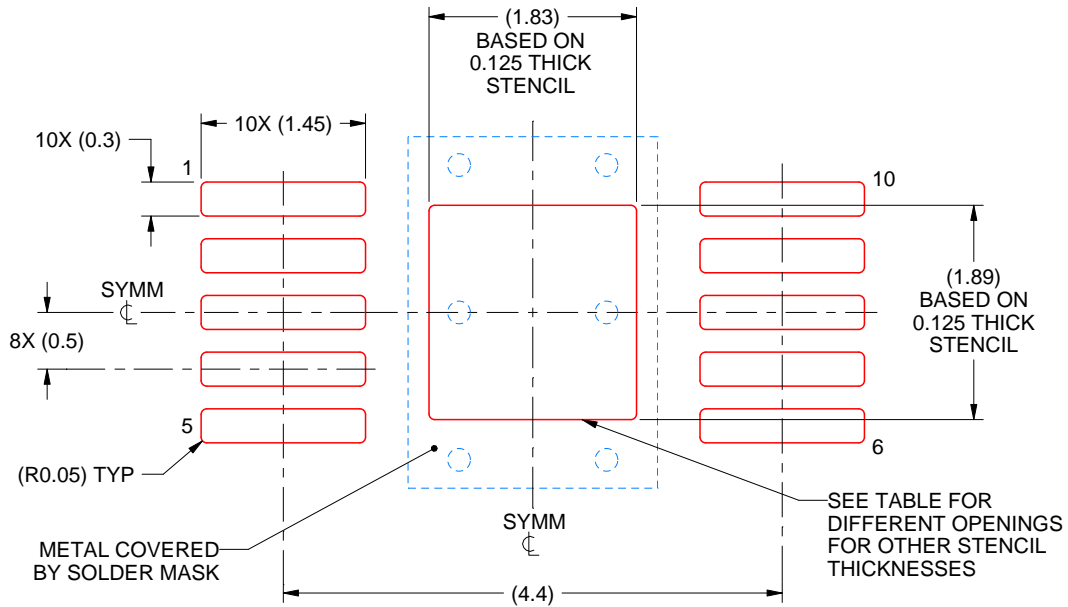

SOLDER PASTE EXAMPLE  
EXPOSED PAD  
100% PRINTED SOLDER COVERAGE BY AREA  
SCALE:15X

STENCIL THICKNESS	SOLDER STENCIL OPENING
0.1	2.05 X 2.11
0.125	1.83 X 1.89 (SHOWN)
0.150	1.67 X 1.73
0.175	1.55 X 1.60

4218842/A 01/2019

NOTES: (continued)

10. Laser cutting apertures with trapezoidal walls and rounded corners may offer better paste release. IPC-7525 may have alternate design recommendations.
11. Board assembly site may have different recommendations for stencil design.

## IMPORTANT NOTICE AND DISCLAIMER

TI PROVIDES TECHNICAL AND RELIABILITY DATA (INCLUDING DATASHEETS), DESIGN RESOURCES (INCLUDING REFERENCE DESIGNS), APPLICATION OR OTHER DESIGN ADVICE, WEB TOOLS, SAFETY INFORMATION, AND OTHER RESOURCES "AS IS" AND WITH ALL FAULTS, AND DISCLAIMS ALL WARRANTIES, EXPRESS AND IMPLIED, INCLUDING WITHOUT LIMITATION ANY IMPLIED WARRANTIES OF MERCHANTABILITY, FITNESS FOR A PARTICULAR PURPOSE OR NON-INFRINGEMENT OF THIRD PARTY INTELLECTUAL PROPERTY RIGHTS.

These resources are intended for skilled developers designing with TI products. You are solely responsible for (1) selecting the appropriate TI products for your application, (2) designing, validating and testing your application, and (3) ensuring your application meets applicable standards, and any other safety, security, or other requirements. These resources are subject to change without notice. TI grants you permission to use these resources only for development of an application that uses the TI products described in the resource. Other reproduction and display of these resources is prohibited. No license is granted to any other TI intellectual property right or to any third party intellectual property right. TI disclaims responsibility for, and you will fully indemnify TI and its representatives against, any claims, damages, costs, losses, and liabilities arising out of your use of these resources.

TI's products are provided subject to TI's Terms of Sale (<https://www.ti.com/legal/termsofsale.html>) or other applicable terms available either on [ti.com](https://www.ti.com) or provided in conjunction with such TI products. TI's provision of these resources does not expand or otherwise alter TI's applicable warranties or warranty disclaimers for TI products.

Mailing Address: Texas Instruments, Post Office Box 655303, Dallas, Texas 75265  
Copyright © 2021, Texas Instruments Incorporated