



THERMISTOR SIGNAL AMPLIFIER FOR TEMPERATURE CONTROL

FEATURES

- **OPTIMIZED FOR PRECISION 10kΩ THERMISTOR APPLICATIONS**
 - **LOW OFFSET OVER TEMPERATURE:**
0.009°C Temperature Error, -40°C to +85°C
 - **EXCELLENT LONG-TERM STABILITY**
 - **VERY LOW 1/f NOISE: (0.01Hz to 10Hz)**
(Peak-to-Peak Equivalent to 0.0001°C)
- **WIDE OUTPUT SWING:** Within 10mV of Rails
- **SUPPLY RANGE:** Single +2.7V to +5.5V
- **microPACKAGE:** MSOP-10
- **REQUIRES ONLY ONE PRECISION RESISTOR**

APPLICATIONS

- **THERMISTOR-BASED TEMPERATURE CONTROLLERS FOR OPTICAL NETWORKING**
- **HIGH ACCURACY FOR TEC APPLICATIONS**
- **LASER TEMPERATURE CONTROL**

DESCRIPTION

The INA330 is a precision amplifier designed for thermoelectric cooler (TEC) control in optical networking applications. It is optimized for use in 10kΩ thermistor-based temperature controllers. The INA330 provides thermistor excitation and generates an output voltage proportional to the difference in resistances applied to the inputs. It uses only one precision resistor plus the thermistor, thus providing an alternative to the traditional bridge circuit. This new topology eliminates the need for two precision resistors while maintaining excellent accuracy for temperature control applications.

An excitation voltage is applied to the thermistor (R_{THERM}) and precision resistor (R_{SET}), creating currents I_1 and I_2 . The current conveyor circuit produces an output current, I_O , equal to $I_1 - I_2$, which flows through the external gain-setting resistor. A buffered voltage output proportional to I_O is also provided.

The INA330 offers excellent long-term stability, and very low 1/f noise throughout the life of the product. The low offset results in a 0.009°C temperature error from -40°C to +85°C. It comes in MSOP-10 packaging and operates with supply voltages from +2.7V to +5.5V. It is specified over the industrial temperature range, -40°C to +85°C, with operation from -40°C to +125°C.

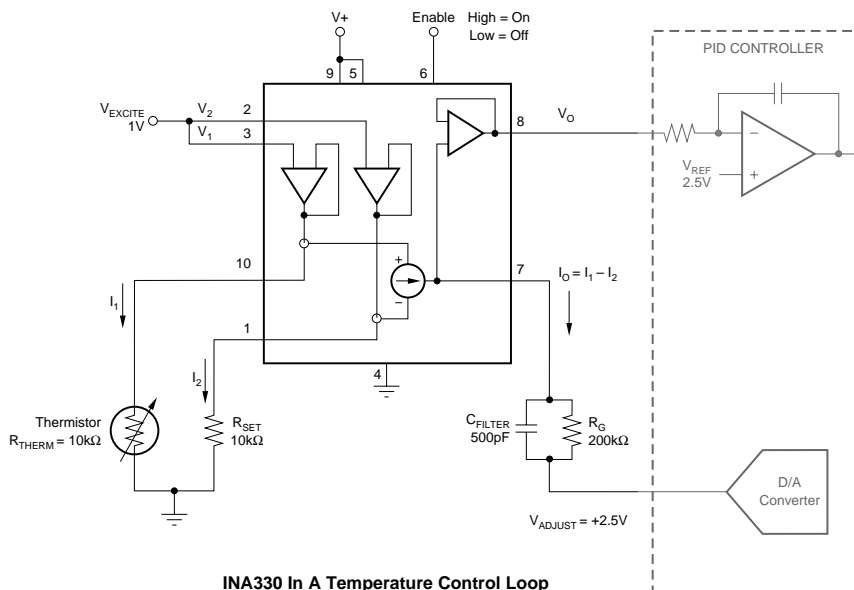

Please be aware that an important notice concerning availability, standard warranty, and use in critical applications of Texas Instruments semiconductor products and disclaimers thereto appears at the end of this data sheet.

ABSOLUTE MAXIMUM RATINGS⁽¹⁾

Supply Voltage	+5.5V
Signal Input Terminals: (Pins 1, 2, 3, 6, and 10) Voltage ⁽²⁾	-0.5V to (V+) + 0.5V
Current ⁽²⁾	±10mA
Output Short-Circuit ⁽³⁾	Continuous
Operating Temperature Range	-40°C to +125°C
Storage Temperature Range	-65°C to +150°C
Junction Temperature	+150°C
Lead Temperature (soldering, 10s)	+300°C

NOTES: (1) Stresses above these ratings may cause permanent damage. Exposure to absolute maximum conditions for extended periods may degrade device reliability. These are stress ratings only, and functional operation of the device at these or any other conditions beyond those specified is not implied. (2) Input terminals are diode clamped to the power-supply rails. Input signals that can swing more than 0.5V beyond the supply rails should be current limited to 10mA or less. (3) Short-circuit to ground.



ELECTROSTATIC DISCHARGE SENSITIVITY

This integrated circuit can be damaged by ESD. Texas Instruments recommends that all integrated circuits be handled with appropriate precautions. Failure to observe proper handling and installation procedures can cause damage.

ESD damage can range from subtle performance degradation to complete device failure. Precision integrated circuits may be more susceptible to damage because very small parametric changes could cause the device not to meet its published specifications.

PACKAGE/ORDERING INFORMATION

PRODUCT	PACKAGE-LEAD	PACKAGE DESIGNATOR ⁽¹⁾	SPECIFIED TEMPERATURE RANGE	PACKAGE MARKING	ORDERING NUMBER	TRANSPORT MEDIA, QUANTITY
INA330 "	MSOP-10 "	DGS "	-40°C to +85°C "	TLB "	INA330AIDGST INA330AIDGSR	Tape and Reel, 250 Tape and Reel, 2500

NOTE: (1) For the most current specifications and package information, refer to our web site at www.ti.com.

PIN CONFIGURATION

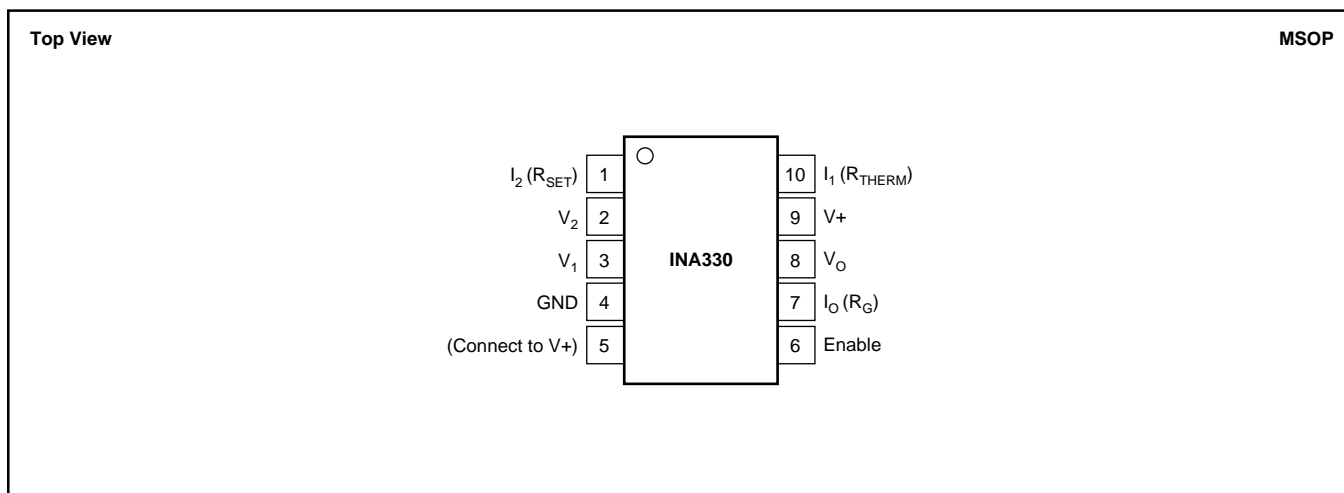

ELECTRICAL CHARACTERISTICS: $V_S = +5V$

BOLDFACE limits apply over the specified temperature range, $T_A = -40^{\circ}C$ to $+85^{\circ}C$

At $T_A = +25^{\circ}C$, $V_1 = V_2 = +1V$, $V_{ADJUST} = +2.5V$, $R_{SET} = 10k\Omega$, $R_{THERM} = 10k\Omega$, $R_G = 200k\Omega$, $C_{FILTER} = 500pF$, external 1kHz filtering, unless otherwise noted.

PARAMETER	CONDITION	INA330			UNITS
		MIN	TYP	MAX	
VOLTAGE EXCITATION BUFFERS					
Voltage Range	$R_{SET} = 10k\Omega$, $R_{THERM} = 10k\Omega$ $R_{SET} = 100k\Omega$, $R_{THERM} = 100k\Omega$ $V_S = +5V$, $V_1 - V_2 = 0$	0.1	0.1 to 4.9	1.25	V
Offset Voltage vs Temperature	V_{OS}		± 60		μV
Offset Voltage vs Power Supply	ΔV_{OS}		± 0.2		$\mu V/^{\circ}C$
Offset Voltage Match ⁽¹⁾ vs Temperature	PSR		3		$\mu V/V$
Input Bias Current	I_B		± 30		$\mu V/^{\circ}C$
Output Current			0.2		nA
			± 0.2		nA
				+125	μA
CURRENT CONVEYOR⁽²⁾					
Gain Equation			$I_O = I_1 - I_2$		μA
Current Output Range		± 12.5			V
Voltage Compliance Range		0.075		4.925	A/A
Gain			1		%
Gain Error	$V_O = +0.075V$ to $+4.925V$		± 0.1	± 0.2	%
Current Offset Error	$I_1 = I_2$		± 100	± 200	nA
Change Over Temperature vs V_1 , V_2	$+25^{\circ}C$ to $+85^{\circ}C$, or $+25^{\circ}C$ to $-40^{\circ}C$		± 100	± 40	nA
vs Power Supply	$V_1 = V_2 = +0.1V$ to $+1.25V$		25	± 200	nA/V
Noise Current			12		nA/V
f = 0.01Hz to 10Hz			500		pA/ \sqrt{Hz}
					pAp-p
OUTPUT BUFFER					
Voltage Output Swing-to-Rail	$R_L = 100k\Omega$ $R_L = 10k\Omega$	75	5 10 30		mV
Offset Voltage vs Temperature	dV_{OS}/dT		0.1		mV
Input Bias Current			Included in I_{ERROR}		$\mu V/^{\circ}C$
Short-Circuit Current	I_{SC}		± 25		mA

NOTES: (1) Total errors in voltage seen between pin 1 and pin 10. (2) See Figure 2.

TEST CONFIGURATION

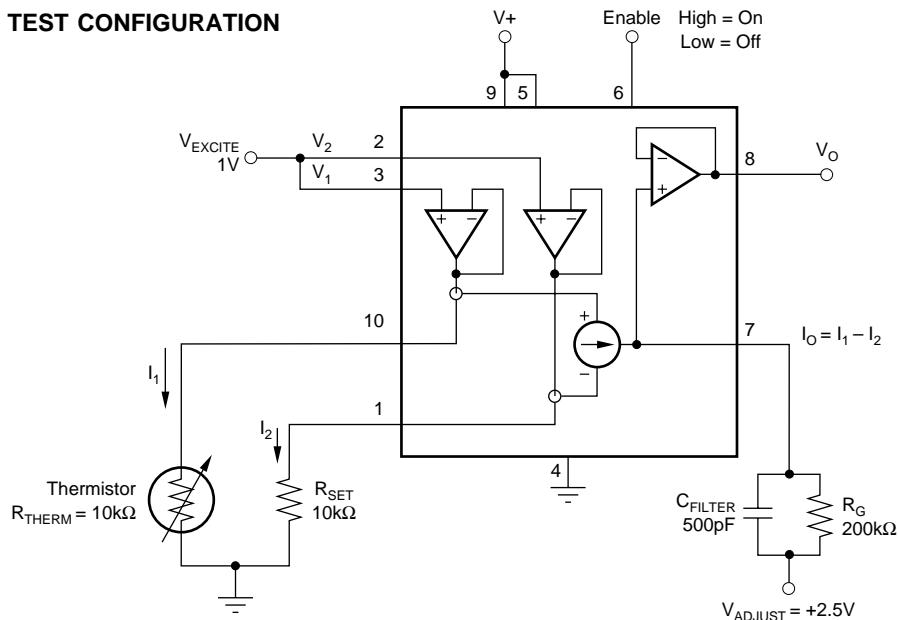

ELECTRICAL CHARACTERISTICS: $V_S = +5V$ (Cont.)

BOLDFACE limits apply over the specified temperature range, $T_A = -40^{\circ}C$ to $+85^{\circ}C$.

At $T_A = +25^{\circ}C$, $V_1 = V_2 = +1V$, $V_{ADJUST} = +2.5V$, $R_{SET} = 10k\Omega$, $R_{THERM} = 10k\Omega$, $R_G = 200k\Omega$, $C_{FILTER} = 500pF$, external 1kHz filtering, unless otherwise noted.

PARAMETER	CONDITION	INA330			UNITS
		MIN	TYP	MAX	
FREQUENCY RESPONSE					
Bandwidth, $-3dB^{(3)}$	BW		1		kHz
Slew Rate	SR		Not Slew Rate Limited		
POWER SUPPLY					
Specified Voltage Range	$I_O = 0$, $V_1 - V_2 = 0V$, $V_S = +5V$	+2.7	2.6	+5.5	V
Quiescent Current				3.6	mA
Over Temperature				3.9	mA
SHUTDOWN					
Disable (Logic LOW Threshold)	$V_S = +5V$, Disabled	1.6	75	0.25	V
Enable (Logic HIGH Threshold)					V
Enable Time					μs
Disable Time					μs
Shutdown Current and Enable Pin Current					μA
TEMPERATURE RANGE					
Specified Range	MSOP-10 Surface-Mount	-40	150	+85	$^{\circ}C$
Operating Range		-40		+125	$^{\circ}C$
Storage Range		-65		+150	$^{\circ}C$
Thermal Resistance					$^{\circ}C/W$

NOTES: (3) Dynamic response is limited by filtering.

TYPICAL CHARACTERISTICS

At $T_A = +25^\circ\text{C}$, $V_1 = V_2 = +1\text{V}$, $V_{\text{ADJUST}} = +2.5\text{V}$, $R_{\text{SET}} = 10\text{k}\Omega$, $R_{\text{THERM}} = 10\text{k}\Omega$ (5%), $R_G = 200\text{k}\Omega$, $C_{\text{FILTER}} = 500\text{pF}$, and external 1kHz filtering, unless otherwise noted.

CURRENT CONVEYOR OFFSET ERROR
PRODUCTION DISTRIBUTION

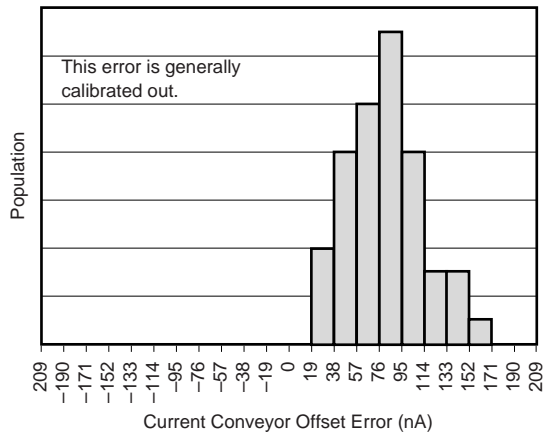

CURRENT CONVEYOR OFFSET ERROR
CHANGE OVER TEMPERATURE
PRODUCTION DISTRIBUTION

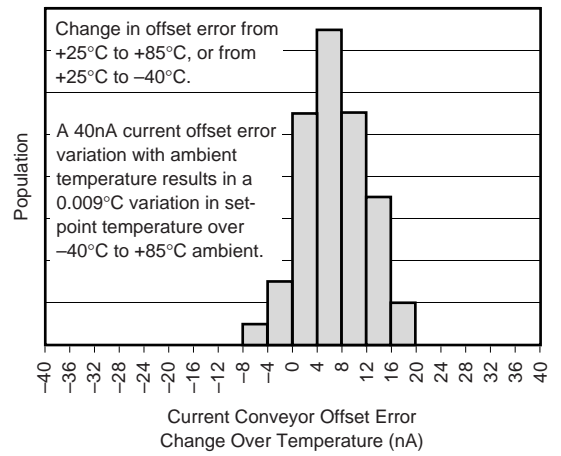

0.01Hz TO 10Hz VOLTAGE NOISE

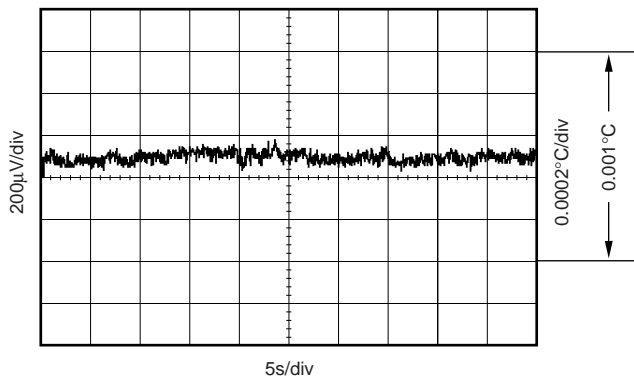

Test Configuration
for this page.

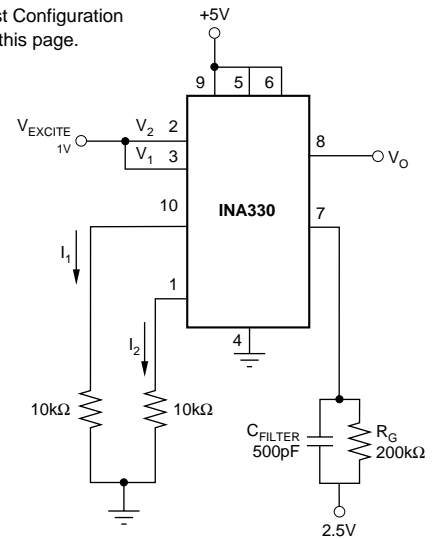

APPLICATIONS INFORMATION

OVERVIEW

Precision temperature controllers are generally adjusted to their set-point temperature to achieve the desired system performance and to compensate for tolerance of the thermistor and reference circuitry. After this adjustment, the crucial issue is the stability of this set-point temperature. When used in a temperature control loop (Figure 1), the INA330 provides excellent control-point stability over time and ambient temperature changes. Low 1/f noise assures excellent short-term stability. Internal auto-zero circuitry assures excellent stability throughout product life.

SOURCES OF ERRORS

The largest source of error in a control system will occur due to R_{SET} , see "Selecting Components" section.

The INA330 errors are extremely low. The primary errors in the INA330 occur in the current conveyer circuitry, as shown in Figure 2. Equal currents in R_{SET} and R_{THERM} produce a small output current error of 200nA (maximum), and some variation with temperature of 40nA (maximum). The offset is calibrated out. Only the variation affects set-point stability.

The variation can be referred to the input as a set-point temp variation: 10k Ω thermistor with a 4.5% temperature coefficient, ($\alpha = -0.045$) changes resistance by 450 $\Omega/^{\circ}C$. This results in 4500nA change in I_1 for a 1 $^{\circ}C$ temperature change at the thermistor. Therefore, the 40nA maximum current offset error variation with ambient temperature results in a 0.009 $^{\circ}C$ variation in set-point temperature over -40 $^{\circ}C$ to +85 $^{\circ}C$ ambient (40nA/4500nA/ $^{\circ}C = 0.009^{\circ}C$ set-point/ $^{\circ}C$

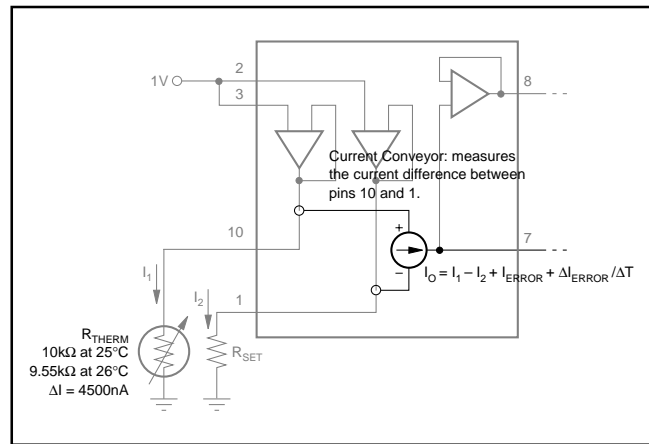

FIGURE 2. Current Conveyor Portion of the INA330.

ambient). This is the variation in set-point temperature due to variation in ambient temperature of the INA330.

Insignificant Errors

Input offset voltage of the voltage excitation buffers are auto-zeroed to approximately 60 μV and match to 30 μV . Drift with temperature is very low. They contribute negligible error.

Voltage excitation buffers have an input bias current of 0.2nA. With a source impedance of less than 10k Ω , errors produced by the input bias current will be negligible.

Output buffer errors are auto-zeroed. When referred to the input, their errors are negligible.

Gain error does not produce any significant temperature set-point error when used in a temperature set-point control loop.

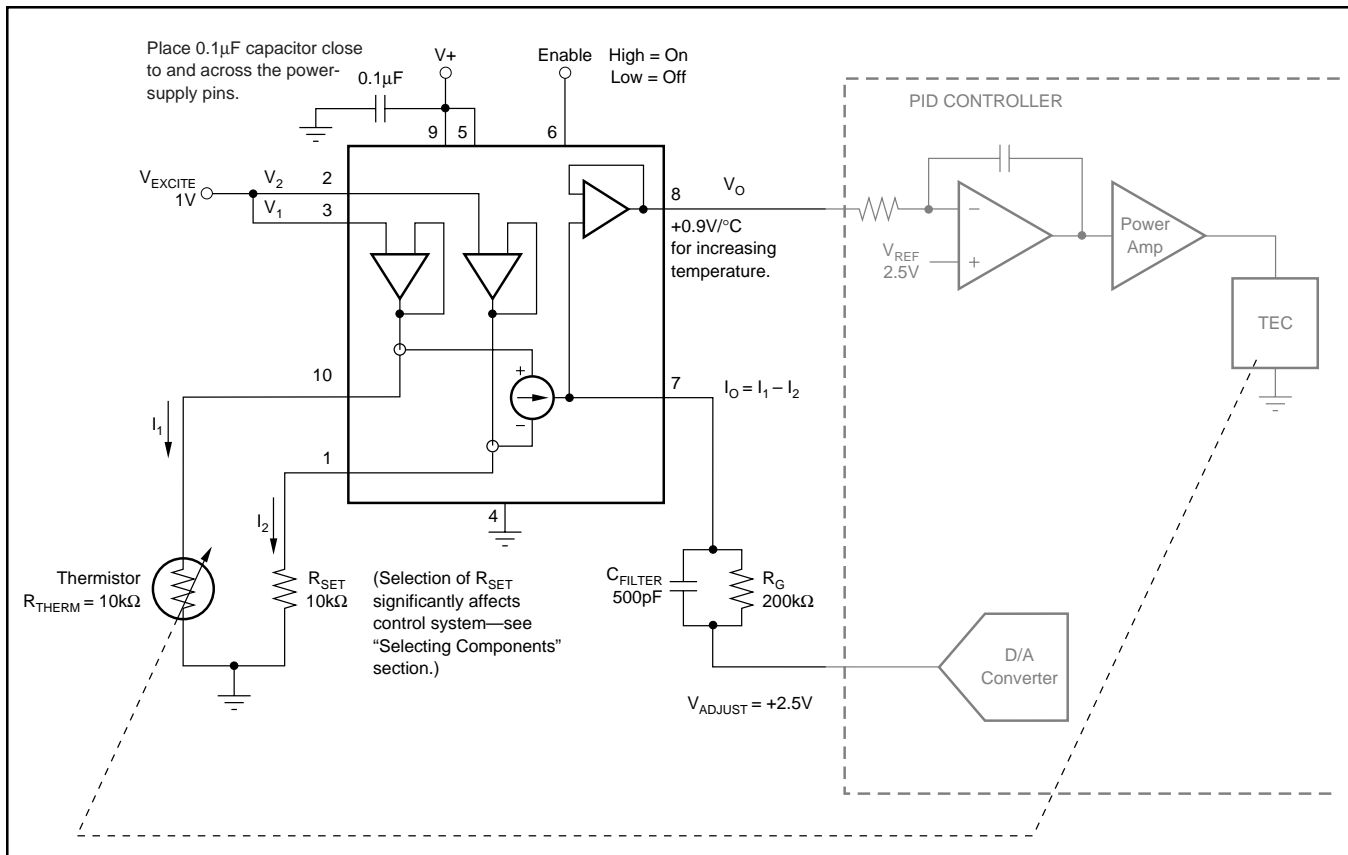

FIGURE 1. The INA330 In Simplified Temperature Control Loop.

SELECTING COMPONENTS

R_{SET} is the primary “reference” for the temperature control loop. Its absolute resistance controls the set-point temperature. Again, its initial accuracy can be calibrated, but its stability is crucial. Therefore, a high-quality, low-temperature coefficient type must be used.

A 25ppm/°C precision resistor changes 0.15% from –40°C to +85°C. This will produce a 0.03°C change in set-point temperature. This error is approximately three-times larger than that produced by the INA330.

The transfer function for the configuration shown in Figure 3 is:

$$V_O = V_{ADJ} + R_G(I_1 - I_2)$$

or

$$V_O = V_{ADJ} + R_G \left(\frac{V_1}{R_{THERM}} - \frac{V_2}{R_{SET}} \right)$$

With $V_1 = V_2 = V_{EXCITE}$,

$$V_O = V_{ADJ} + V_{EXCITE} R_G \left(\frac{1}{R_{THERM}} - \frac{1}{R_{SET}} \right)$$

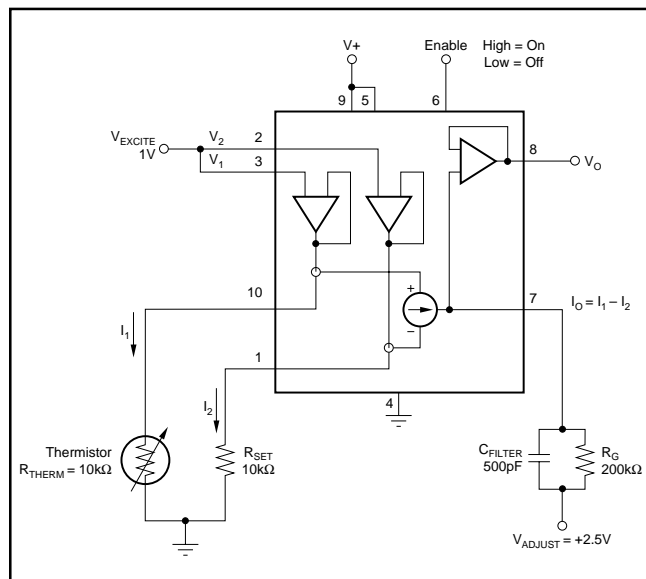

FIGURE 3. Basic Configuration for the INA330.

Nominal values should use $R_{SET} = R_{THERM} = 10k\Omega$ at the designed control temperature. Values less than 2kΩ can cause the voltage excitation buffers to become unstable. The buffer connected to pin 10 is characterized and tested to supply the changing current in the thermistor. The thermistor should not be connected to pin 1. An inversion of the control

loop can be accomplished by simply reversing the connections to the TEC, or by creating the desired polarity in the intervening control circuitry. If differing values of V_1 and V_2 are used, resistor values should be chosen to maintain balanced currents, I_1 and I_2 . Likewise, if a lower value of R_{SET} is used, the excitation voltage must be lowered to keep I_1 and I_2 at or below 125μA.

C_{FILTER} is calculated by:

$$C_{FILTER} = \frac{1}{2\pi R_G (1.6kHz)}$$

NOISE PERFORMANCE

Temperature control loops require low noise over a small bandwidth, typically 10Hz, or less. The INA330’s internal auto-correction circuitry eliminates virtually all 1/f noise (noise that increases at low frequency). The peak-to-peak voltage noise due to I_{ERROR} , R_{THERM} , R_{SET} , and the buffers at 0.01Hz to 10Hz results in a 0.0001°C contribution.

OUTPUT

The INA330 output (pin 8) is capable of swinging to within 10mV of the power-supply rails. It is able to achieve rail-to-rail output performance while sinking or sourcing 12.5μA.

V_{ADJUST} can be used to create an offset voltage around which the output can be centered.

ENABLE FUNCTION

The INA330 is enabled by applying a logic HIGH voltage level to the Enable pin. Conversely, a logic LOW voltage level will disable the amplifier, reducing its supply current from 2.6mA to typically 2μA. This pin should be connected to a valid HIGH or LOW voltage or driven, not left open circuit. Applications not requiring disable can connect pin 6 directly to V+. The Enable pin can be modeled as a CMOS input gate, as shown in Figure 4.

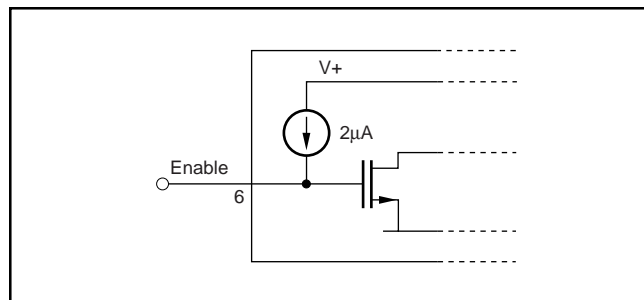

FIGURE 4. Enable Pin Model.

INSIDE THE INA330

The INA330 is designed and tested for amplifying 10kΩ thermistor signals used in the control of thermoelectric coolers for optical networking applications. The simplified schematic in Figure 5 shows the basic function of the INA330. An excitation voltage is applied as V_1 and V_2 . Typically, these voltages are equal. They generate currents I_1 and I_2 in the thermistor and R_{SET} resistor.

Auto-corrected current mirror circuitry around A_1 and A_2 produce an output current, I_o , equal to the difference

current $I_1 - I_2$. The gain is set by the value of R_G . The output voltage, V_o , is the voltage resulting from I_o flowing through R_G .

The INA330 uses internal charge pumps to create voltages beyond the power-supply rails. As a result, the voltage on R_G can actually swing 20mV below the negative power-supply rail, and 100mV beyond the positive supply rail. An internal oscillator has a frequency of 90kHz and accuracy of $\pm 20\%$.

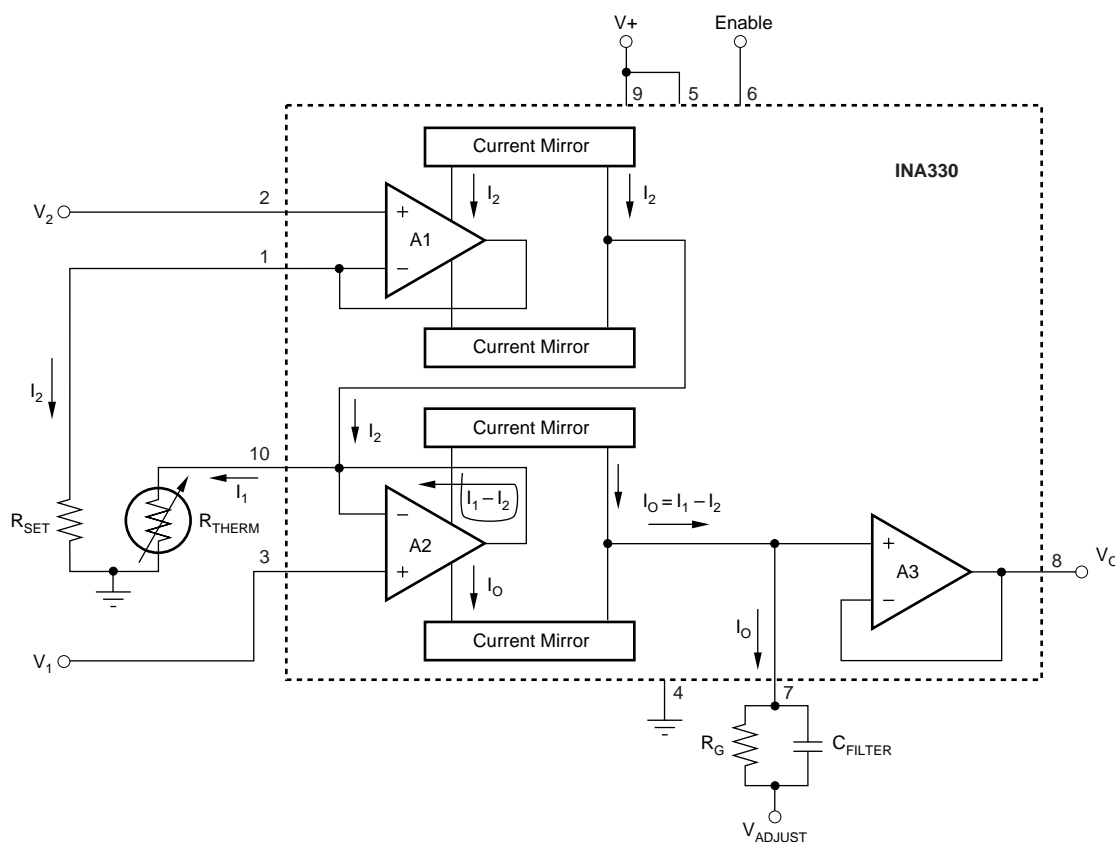

FIGURE 5. INA330 Simplified Schematic.

INA330 PIN 5

Pin 5 of the INA330 should be connected to V_+ to ensure proper operation.

COMPLETE TEMPERATURE CONTROLLER

See Figure 6 for a complete temperature control loop with a TEC (thermoelectric cooler) for cooling and heating. PID (proportional, integral, differential) control circuitry is shown for loop compensation and stability.

The loop controls temperature to an adjustable set-point of 22.5°C to 27.5°C. The nominal 10kΩ at 25°C thermistor ranges from approximately 11.4kΩ to 8.7kΩ over this range. A 1V excitation voltage is applied to V_1 and V_2 , producing a nominal 100μA current in the 10kΩ R_{SET} resistor. The ther-

mistor current is approximately 100μA at 25°C, but will vary above or below this value over the $\pm 2.5^\circ\text{C}$ set-point temperature range. The difference of these two currents flows in the gain-set resistor, R_G . This produces a voltage output of approximately 0.9V/°C.

The set-point temperature is adjusted with V_{ADJ} . Thus, the voltage at V_o is the sum of $(I_o)(R_G) + V_{ADJ}$. V_{ADJ} can be manually adjusted or set with a Digital-to-Analog (D/A) converter. Optionally, set-point temperature can be adjusted by choosing a different fixed value resistor more closely approximating the value of R_{THERM} at the desired temperature.

The noninverting input of the integrator in the PID compensation is connected to V_{BIAS} . Thus, the feedback loop will drive the heating or cooling of the TEC to force V_o to equal $V_{BIAS} - V_{ADJ} = 2.5\text{V}$ will produce a set-point temperature of

25°C. $V_{ADJ} = 2.5V + 0.9V$ will change the set-point by 1°C. A 0V to 5V D/A converter will provide approximately $\pm 2.5^\circ\text{C}$ adjustment range. A 12-bit D/A converter will allow for approximately 0.001°C resolution on the set-point temperature.

For best temperature stability, the set-point temperature voltage should be derived ratiometrically from V_{BIAS} . A D/A converter used to derive the set-point voltage should share the same reference voltage source as V_{BIAS} . Likewise, the 1V

source for V_1 and V_2 should be derived from the same reference.

The PID loop compensation can be optimized for loop stability and best response to thermal transients by adjusting C_1 , C_2 , C_3 , R_2 , R_3 , and R_4 . This is highly dependant on the thermal characteristics of the temperature-controlled block and thermistor/TEC mounting. Figure 7 shows a circuit that can be used as an intermediate circuit to easily adjust components and determine system requirements.

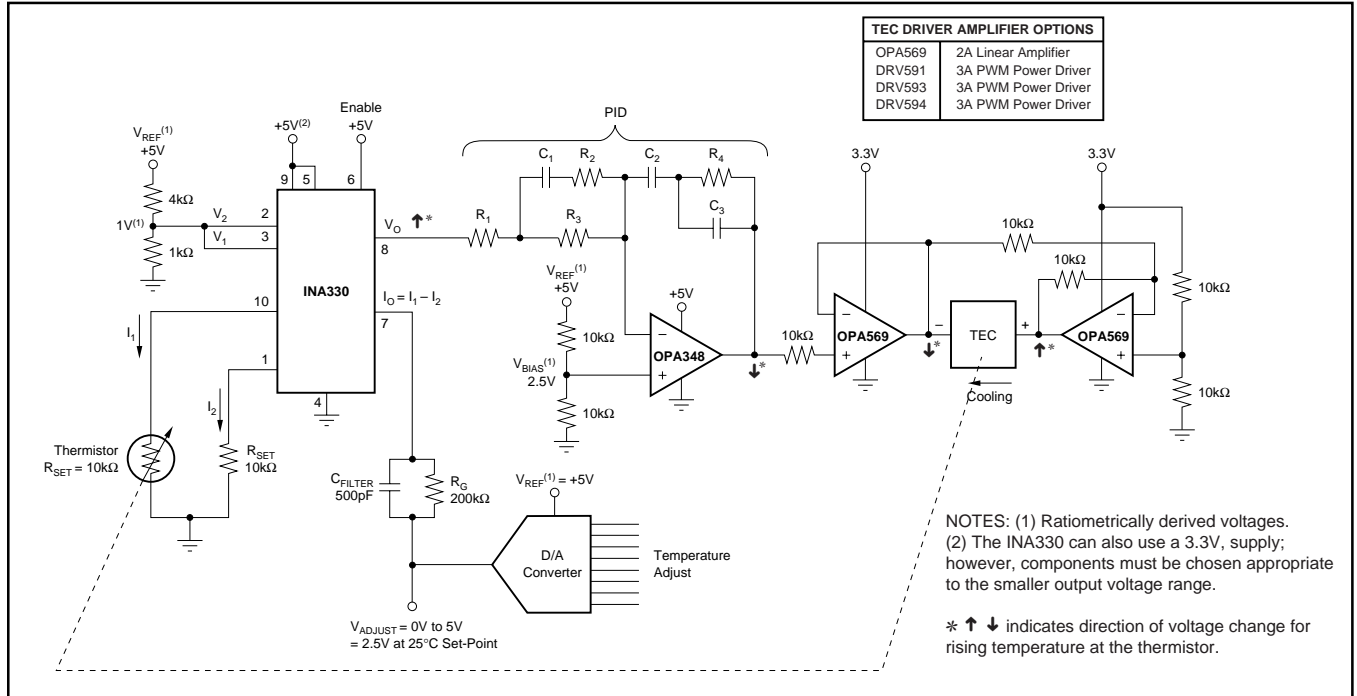

FIGURE 6. PID Temperature Control Loop.

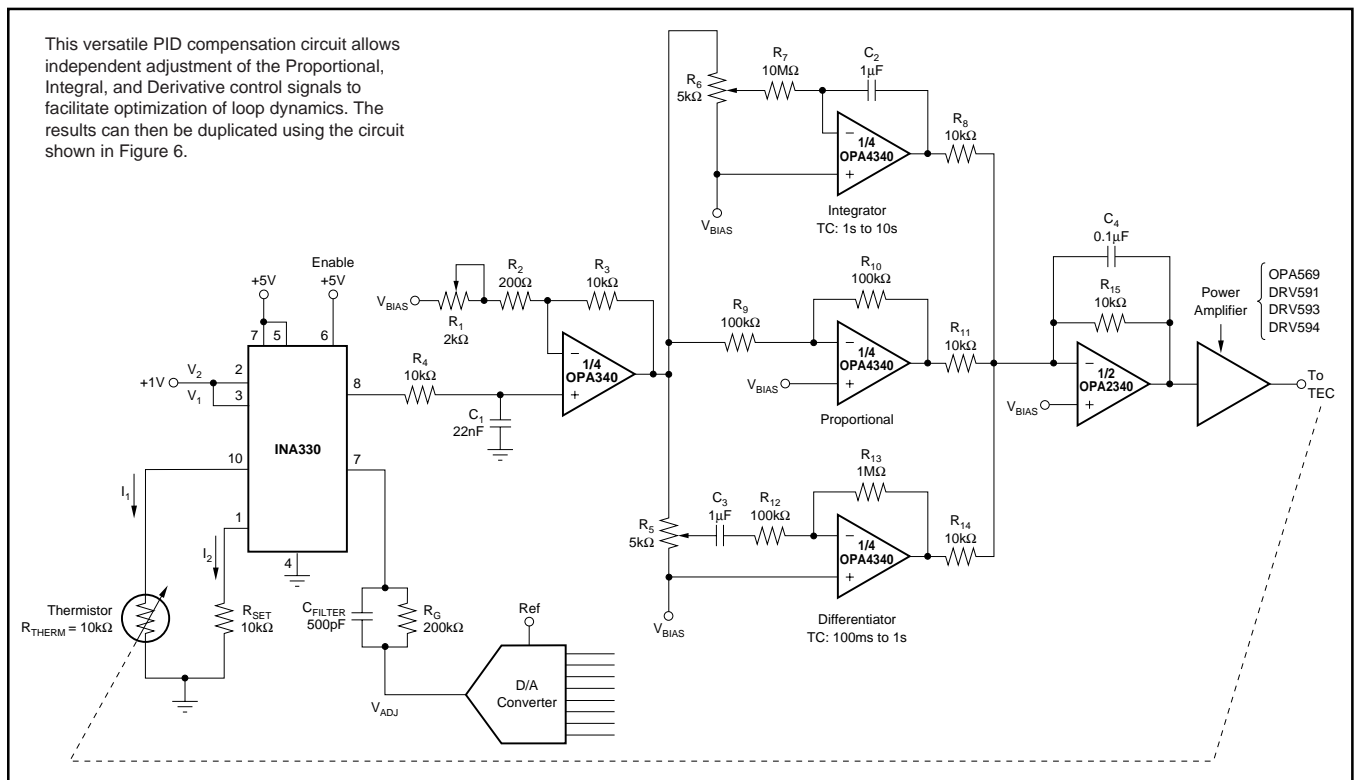

FIGURE 7. Diagnostic and Optimization PID Temperature Control Loop.

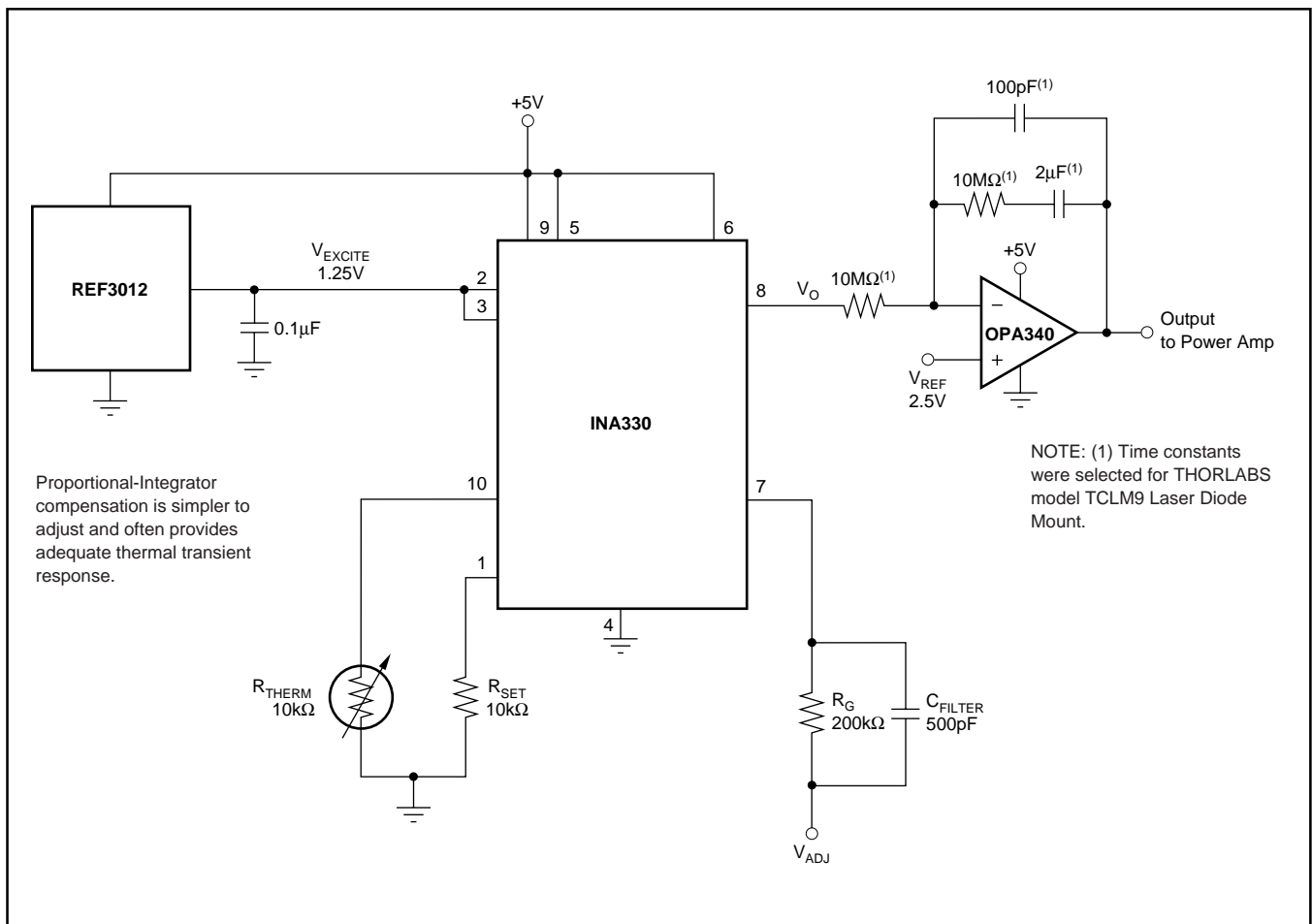

FIGURE 8. Simple PI Temperature Control Amplifier.

FILTERING

Subsequent stages will frequently provide adequate filtering for the INA330. However, filtering can be adjusted through selection of $R_G C_{\text{FILTER}}$, and by adding a filter at V_O for the desired trade-off of noise and bandwidth. Adjustment of these components will result in more or less ripple due to auto-correction circuitry noise and will also affect broadband noise.

It is generally desirable to keep any resistor added at V_O (see R_O in Figure 9) relatively low to avoid DC gain error created by the subsequent stage loading. This may result in relatively high values for the filter capacitor at V_O to produce the desired filter response. The impedance of this filter can be scaled higher to produce smaller capacitor values if the load impedance is very high. Electrolytic capacitors are not recommended for the filters due to dielectric absorption effects.

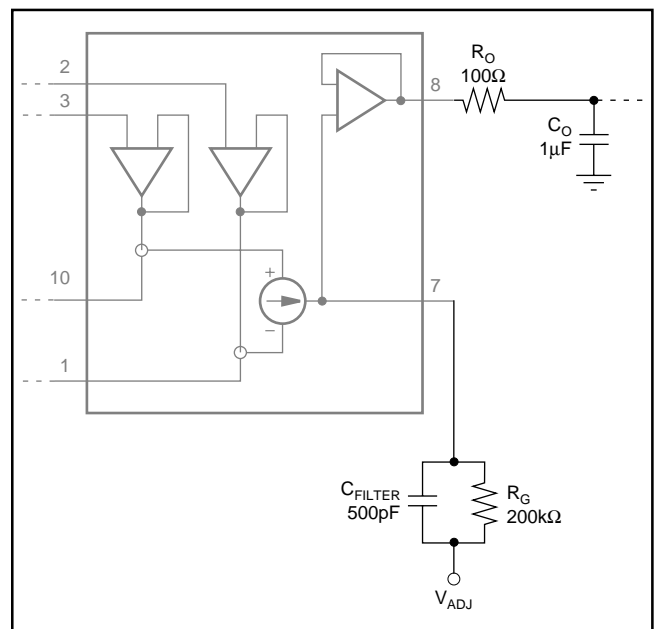

FIGURE 9. Required 1.6kHz (or lower) Filtering.

DIGITALLY COMPENSATED LOOP

The PID compensation can be replaced with a microcontroller or DSP, as shown in Figure 10. An Analog-to-Digital (A/D) converter would be used to digitize the output of the INA330. The analog PID provides sufficient filtering inherently, and, therefore requires no additional filtering. The digital control loop shown in Figure 10 does not provide this inherent filtering, requiring additional output filtering (R_O and C_O) as shown to avoid sampling the internal chopping noise of the INA330 and the A/D converter input and affecting accuracy. High-frequency noise is created by internal auto-correction circuitry and is highly dependent on the filter characteristics

chosen. "Spurs" occur at approximately 90kHz and its harmonics which is reduced by additional filtering at or below 1kHz. This may be the dominant source of noise visible when viewing the output on an oscilloscope. Low cutoff frequency filters will provide lowest noise.

TRADITIONAL BRIDGE CIRCUIT

The traditional bridge circuit (Figure 11) uses three matched resistors and a thermistor to detect temperature changes. The INA326 and INA327 instrumentation amplifiers are well suited to a bridge implementation for thermistor measurement.

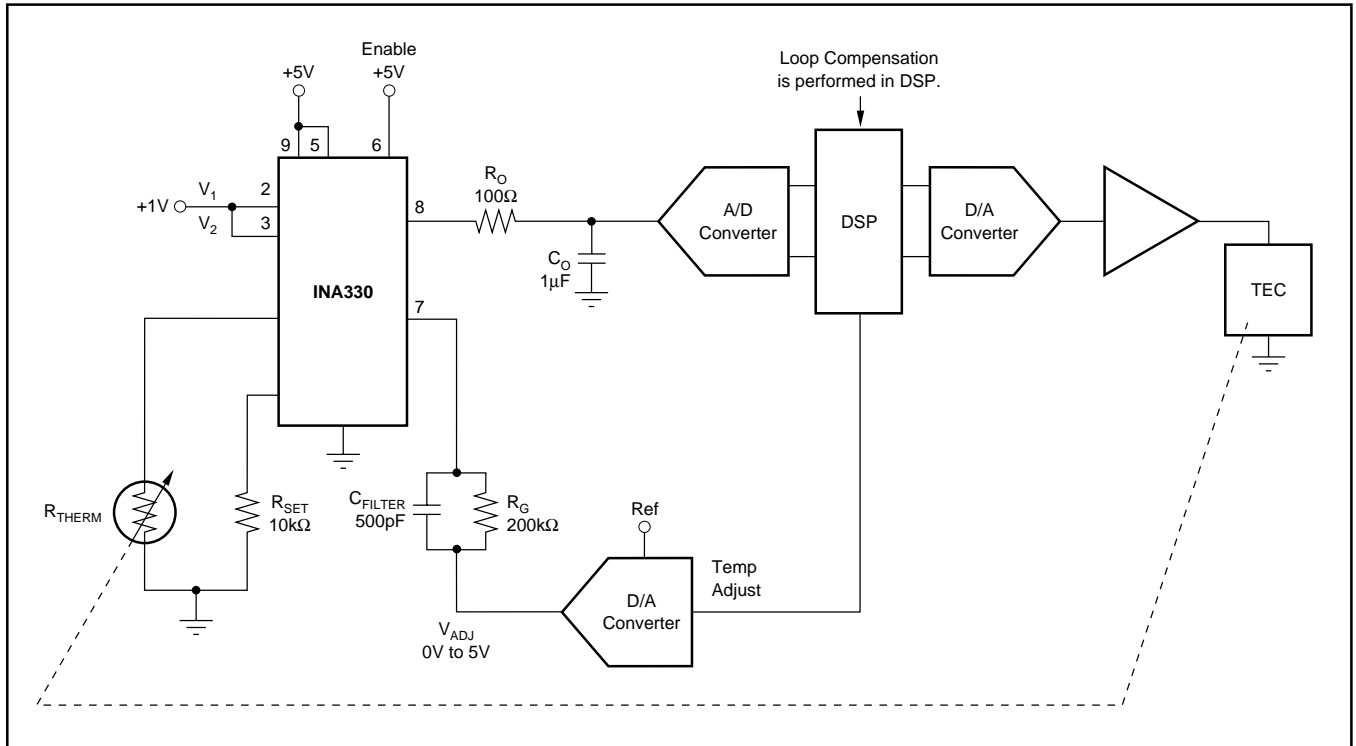

FIGURE 10. Digitally Compensated Loop.

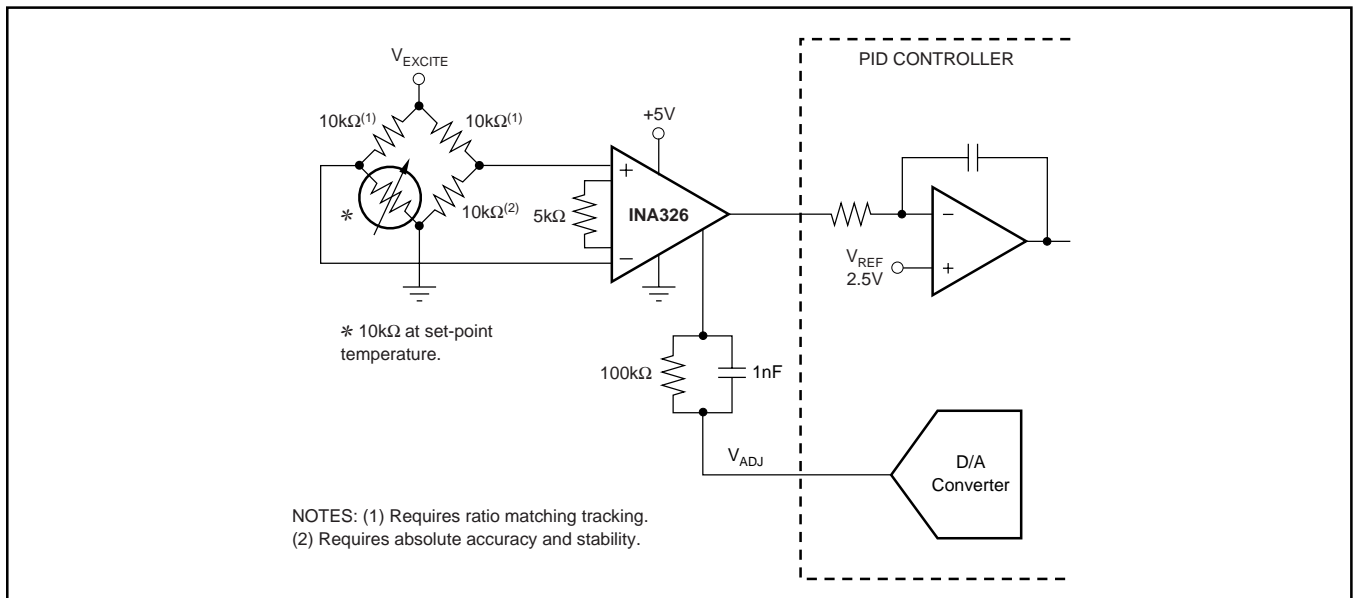
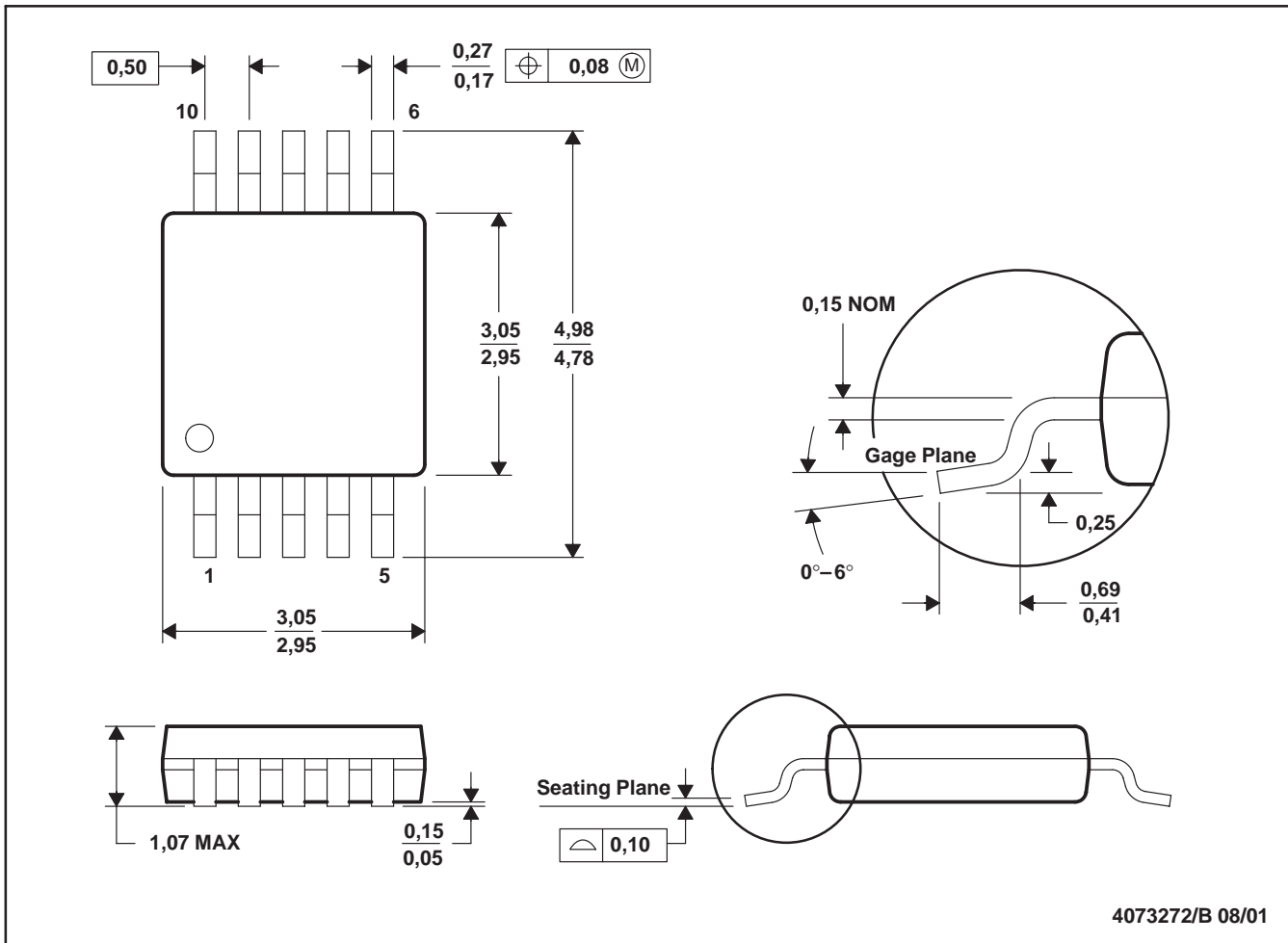

FIGURE 11. Traditional Bridge Circuit.



- NOTES: A. All linear dimensions are in millimeters.
 B. This drawing is subject to change without notice.
 C. Body dimensions do not include mold flash or protrusion.
 A. Falls within JEDEC MO-187

PACKAGING INFORMATION

Orderable Device	Status (1)	Package Type	Package Drawing	Pins	Package Qty	Eco Plan (2)	Lead finish/ Ball material (6)	MSL Peak Temp (3)	Op Temp (°C)	Device Marking (4/5)	Samples
INA330AIDGST	ACTIVE	VSSOP	DGS	10	250	RoHS & Green	NIPDAUAG	Level-2-260C-1 YEAR	-40 to 85	TLB	Samples

(1) The marketing status values are defined as follows:

ACTIVE: Product device recommended for new designs.

LIFEBUY: TI has announced that the device will be discontinued, and a lifetime-buy period is in effect.

NRND: Not recommended for new designs. Device is in production to support existing customers, but TI does not recommend using this part in a new design.

PREVIEW: Device has been announced but is not in production. Samples may or may not be available.

OBSOLETE: TI has discontinued the production of the device.

(2) **RoHS:** TI defines "RoHS" to mean semiconductor products that are compliant with the current EU RoHS requirements for all 10 RoHS substances, including the requirement that RoHS substance do not exceed 0.1% by weight in homogeneous materials. Where designed to be soldered at high temperatures, "RoHS" products are suitable for use in specified lead-free processes. TI may reference these types of products as "Pb-Free".

RoHS Exempt: TI defines "RoHS Exempt" to mean products that contain lead but are compliant with EU RoHS pursuant to a specific EU RoHS exemption.

Green: TI defines "Green" to mean the content of Chlorine (Cl) and Bromine (Br) based flame retardants meet JS709B low halogen requirements of <=1000ppm threshold. Antimony trioxide based flame retardants must also meet the <=1000ppm threshold requirement.

(3) MSL, Peak Temp. - The Moisture Sensitivity Level rating according to the JEDEC industry standard classifications, and peak solder temperature.

(4) There may be additional marking, which relates to the logo, the lot trace code information, or the environmental category on the device.

(5) Multiple Device Markings will be inside parentheses. Only one Device Marking contained in parentheses and separated by a "-" will appear on a device. If a line is indented then it is a continuation of the previous line and the two combined represent the entire Device Marking for that device.

(6) Lead finish/Ball material - Orderable Devices may have multiple material finish options. Finish options are separated by a vertical ruled line. Lead finish/Ball material values may wrap to two lines if the finish value exceeds the maximum column width.

Important Information and Disclaimer:The information provided on this page represents TI's knowledge and belief as of the date that it is provided. TI bases its knowledge and belief on information provided by third parties, and makes no representation or warranty as to the accuracy of such information. Efforts are underway to better integrate information from third parties. TI has taken and continues to take reasonable steps to provide representative and accurate information but may not have conducted destructive testing or chemical analysis on incoming materials and chemicals. TI and TI suppliers consider certain information to be proprietary, and thus CAS numbers and other limited information may not be available for release.

In no event shall TI's liability arising out of such information exceed the total purchase price of the TI part(s) at issue in this document sold by TI to Customer on an annual basis.

TAPE AND REEL INFORMATION

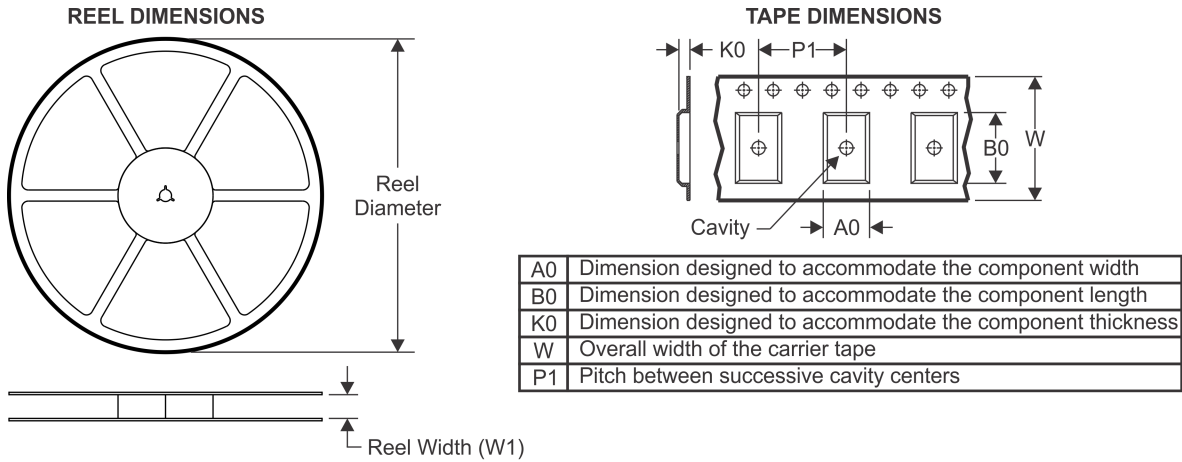

QUADRANT ASSIGNMENTS FOR PIN 1 ORIENTATION IN TAPE



*All dimensions are nominal

Device	Package Type	Package Drawing	Pins	SPQ	Reel Diameter (mm)	Reel Width W1 (mm)	A0 (mm)	B0 (mm)	K0 (mm)	P1 (mm)	W (mm)	Pin1 Quadrant
INA330AIDGST	VSSOP	DGS	10	250	180.0	12.4	5.3	3.4	1.4	8.0	12.0	Q1

TAPE AND REEL BOX DIMENSIONS



*All dimensions are nominal

Device	Package Type	Package Drawing	Pins	SPQ	Length (mm)	Width (mm)	Height (mm)
INA330AIDGST	VSSOP	DGS	10	250	210.0	185.0	35.0

DGS0010A

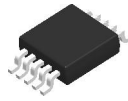

PACKAGE OUTLINE

VSSOP - 1.1 mm max height

SMALL OUTLINE PACKAGE

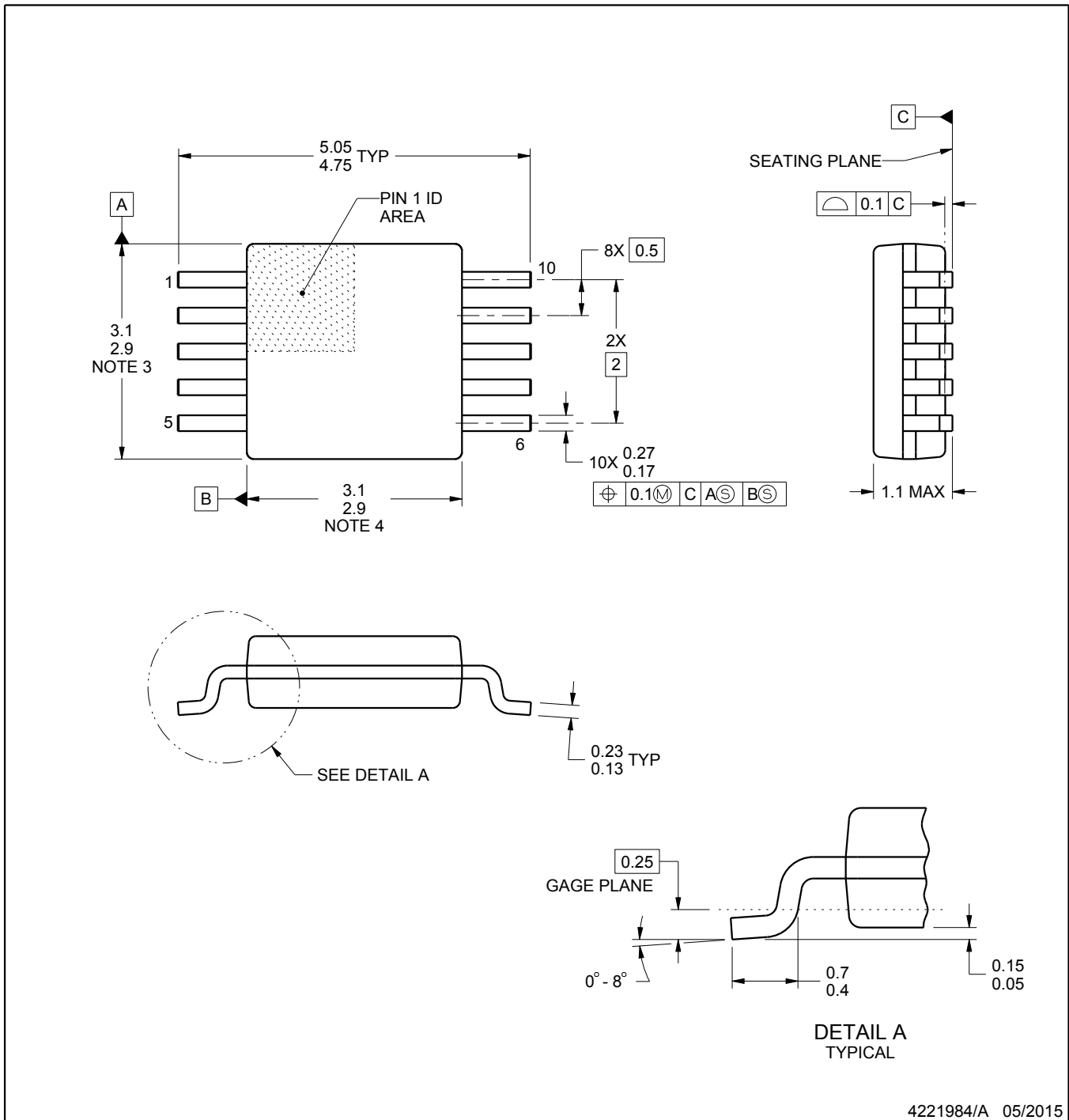

4221984/A 05/2015

NOTES:

1. All linear dimensions are in millimeters. Any dimensions in parenthesis are for reference only. Dimensioning and tolerancing per ASME Y14.5M.
2. This drawing is subject to change without notice.
3. This dimension does not include mold flash, protrusions, or gate burrs. Mold flash, protrusions, or gate burrs shall not exceed 0.15 mm per side.
4. This dimension does not include interlead flash. Interlead flash shall not exceed 0.25 mm per side.
5. Reference JEDEC registration MO-187, variation BA.

EXAMPLE BOARD LAYOUT

DGS0010A

VSSOP - 1.1 mm max height

SMALL OUTLINE PACKAGE

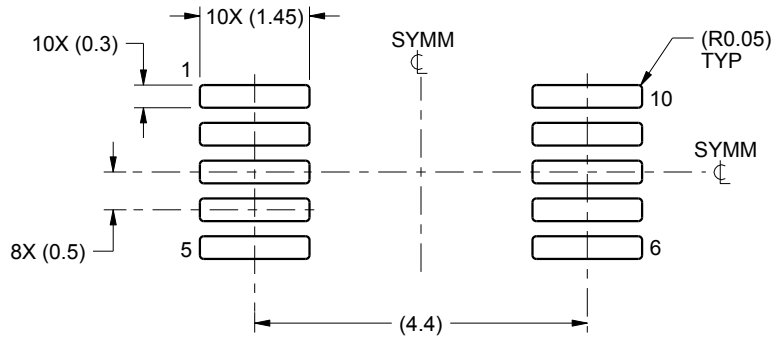

LAND PATTERN EXAMPLE
SCALE:10X

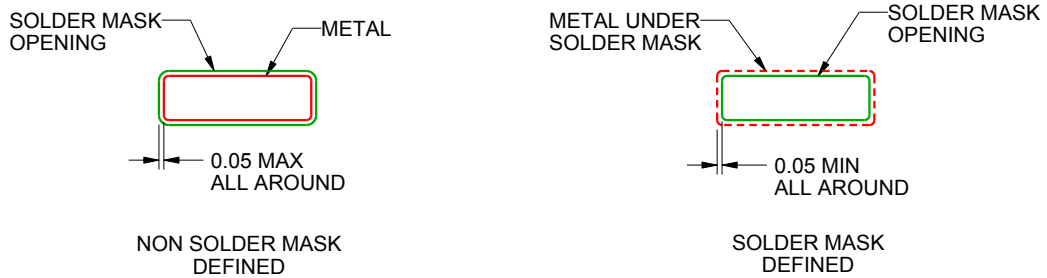

SOLDER MASK DETAILS
NOT TO SCALE

4221984/A 05/2015

NOTES: (continued)

- 6. Publication IPC-7351 may have alternate designs.
- 7. Solder mask tolerances between and around signal pads can vary based on board fabrication site.

EXAMPLE STENCIL DESIGN

DGS0010A

VSSOP - 1.1 mm max height

SMALL OUTLINE PACKAGE

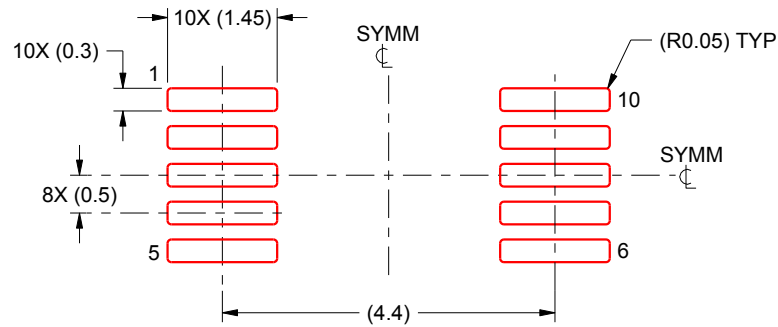

SOLDER PASTE EXAMPLE
BASED ON 0.125 mm THICK STENCIL
SCALE:10X

4221984/A 05/2015

NOTES: (continued)

8. Laser cutting apertures with trapezoidal walls and rounded corners may offer better paste release. IPC-7525 may have alternate design recommendations.
9. Board assembly site may have different recommendations for stencil design.

IMPORTANT NOTICE AND DISCLAIMER

TI PROVIDES TECHNICAL AND RELIABILITY DATA (INCLUDING DATASHEETS), DESIGN RESOURCES (INCLUDING REFERENCE DESIGNS), APPLICATION OR OTHER DESIGN ADVICE, WEB TOOLS, SAFETY INFORMATION, AND OTHER RESOURCES "AS IS" AND WITH ALL FAULTS, AND DISCLAIMS ALL WARRANTIES, EXPRESS AND IMPLIED, INCLUDING WITHOUT LIMITATION ANY IMPLIED WARRANTIES OF MERCHANTABILITY, FITNESS FOR A PARTICULAR PURPOSE OR NON-INFRINGEMENT OF THIRD PARTY INTELLECTUAL PROPERTY RIGHTS.

These resources are intended for skilled developers designing with TI products. You are solely responsible for (1) selecting the appropriate TI products for your application, (2) designing, validating and testing your application, and (3) ensuring your application meets applicable standards, and any other safety, security, or other requirements. These resources are subject to change without notice. TI grants you permission to use these resources only for development of an application that uses the TI products described in the resource. Other reproduction and display of these resources is prohibited. No license is granted to any other TI intellectual property right or to any third party intellectual property right. TI disclaims responsibility for, and you will fully indemnify TI and its representatives against, any claims, damages, costs, losses, and liabilities arising out of your use of these resources.

TI's products are provided subject to TI's Terms of Sale (www.ti.com/legal/termsofsale.html) or other applicable terms available either on ti.com or provided in conjunction with such TI products. TI's provision of these resources does not expand or otherwise alter TI's applicable warranties or warranty disclaimers for TI products.

Mailing Address: Texas Instruments, Post Office Box 655303, Dallas, Texas 75265
Copyright © 2020, Texas Instruments Incorporated