

# TPS2547 带负载检测功能的 USB 充电端口控制器和 3A 电源开关

## 1 特性

- 符合 USB BC 1.2 规范的 D+/D- CDP/DCP 模式
- 符合中国电信行业标准 YD/T 1591-2009 的 D+/D- 短路模式
- 通过自动选择以下模式支持非 BC1.2 充电模式:
  - D+/D- 分压器模式 (2V/2.7V 和 2.7V/2V)
  - D+/D- 1.2V 模式
- 支持休眠模式充电和鼠标/键盘唤醒
- 负载检测 (针对 S4/S5 充电过程中的电源控制以及所有充电模式下的端口电源管理)
- 可兼容 USB 2.0 和 3.0
- 集成 73mΩ (典型值) 高侧金属氧化物半导体场效应晶体管 (MOSFET)
- 3A 可编程 I<sub>LIMIT</sub> 支持 15W 负载
- 工作电压范围: 4.5V 至 5.5V
- 禁用和启用时为 2 μA/270 μA I<sub>Q</sub>
- 插入式, BOM 与 TPS2543/46 兼容
- 16 引脚 WQFN 封装 (3.00 mm × 3.00 mm)
- DM/DP 引脚上的静电放电 (ESD) 额定值达 8kV
- UL 认证文件号 E169910 和 CB 认证 - 待审批

## 2 应用

- USB 端口 (主机和集线器)
- 笔记本和台式机
- 通用墙式充电适配器

## 3 说明

TPS2547 是一款集成有 USB 2.0 高速数据线路 (D+/D-) 开关的 USB 充电端口控制器和电源开关。TPS2547 可在 D+/D- 上提供电气信号, 从而为特性说明部分中列出的充电方案提供支持。TI 使用 TPS2547 对常用的移动电话、平板电脑以及媒体设备进行充电测试, 以确保其既与符合 BC1.2 的器件兼容也与不符合 BC1.2 的器件兼容。

除了支持对常用设备进行充电, TPS2547 还支持两种不同的电源管理功能, 分别为电源唤醒和端口电源管理 (PPM) (通过 STATUS 引脚实现)。电源唤醒允许在 S4/S5 充电中进行电源控制, PPM 支持在多端口系统中进行智能端口电源管理。此外, TPS2547 完全支持带有鼠标/键盘 (适用于低速和高速) 的系统唤醒 (从 S3 唤醒)。

TPS2547 73mΩ 配电开关专门用于可能面临高容性负载和短路问题的应用。凭借两个可编程电流阈值, 该器件可灵活设置电流限值和负载检测阈值。

### 器件信息(1)

器件型号	封装	封装尺寸 (标称值)
TPS2547	WQFN (16)	3.00mm x 3.00mm

(1) 如需了解所有可用封装, 请参阅产品说明书末尾的可订购产品附录。

### 简化原理图

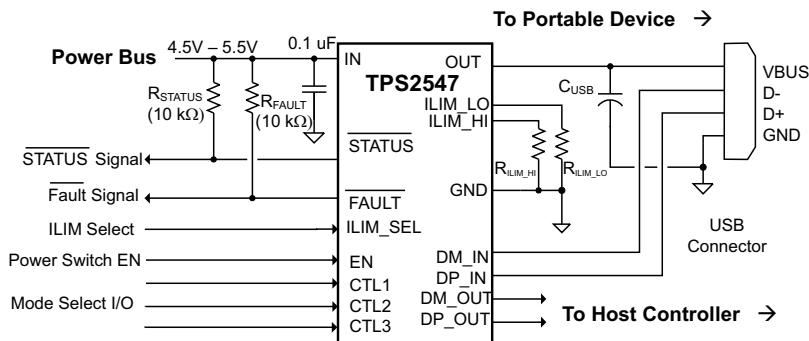

Copyright © 2017, Texas Instruments Incorporated



## 目录

<b>1</b>	特性 .....	1	8.3	Feature Description.....	15
<b>2</b>	应用 .....	1	8.4	Device Functional Modes.....	26
<b>3</b>	说明 .....	1	<b>9</b>	<b>Application and Implementation .....</b>	<b>29</b>
<b>4</b>	修订历史记录 .....	2	9.1	Application Information.....	29
<b>5</b>	<b>Pin Configuration and Functions .....</b>	<b>3</b>	9.2	Typical Application .....	30
<b>6</b>	<b>Specifications.....</b>	<b>4</b>	<b>10</b>	<b>Power Supply Recommendations .....</b>	<b>32</b>
6.1	Absolute Maximum Ratings .....	4	<b>11</b>	<b>Layout.....</b>	<b>32</b>
6.2	ESD Ratings.....	4	11.1	Layout Guidelines .....	32
6.3	Recommended Operating Conditions.....	4	11.2	Layout Example .....	33
6.4	Thermal Information .....	5	<b>12</b>	<b>器件和文档支持 .....</b>	<b>34</b>
6.5	Electrical Characteristics.....	5	12.1	文档支持 .....	34
6.6	Electrical Characteristics: High-Bandwidth Switch....	6	12.2	接收文档更新通知 .....	34
6.7	Electrical Characteristics: Charging Controller .....	7	12.3	社区资源 .....	34
6.8	Typical Characteristics .....	9	12.4	商标 .....	34
<b>7</b>	<b>Parameter Measurement Information .....</b>	<b>13</b>	12.5	静电放电警告.....	34
<b>8</b>	<b>Detailed Description .....</b>	<b>14</b>	12.6	Glossary .....	34
8.1	Overview .....	14	<b>13</b>	<b>机械、封装和可订购信息.....</b>	<b>34</b>
8.2	Functional Block Diagram .....	15			

## 4 修订历史记录

注：之前版本的页码可能与当前版本有所不同。

<b>Changes from Original (May 2017) to Revision A</b>		<b>Page</b>
•	Changed <a href="#">Equation 1</a> .....	30
•	Changed <a href="#">Equation 2</a> .....	31
•	Changed <a href="#">Equation 3</a> .....	31

## 5 Pin Configuration and Functions

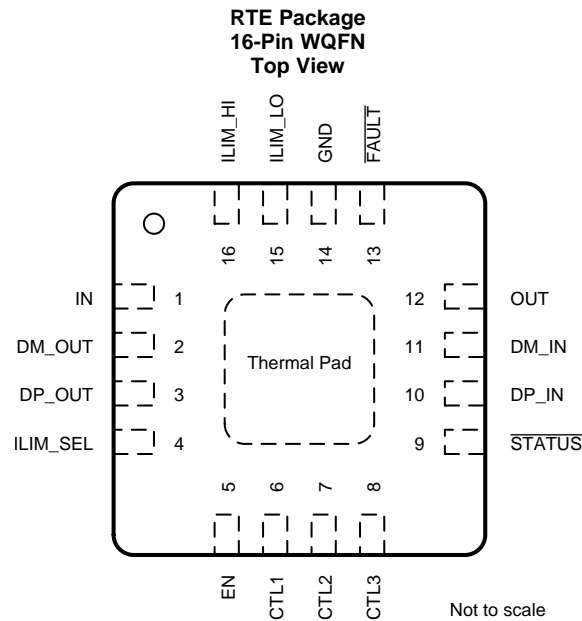

### Pin Functions

PIN		TYPE <sup>(1)</sup>	DESCRIPTION
NO.	NAME		
1	IN	P	Input voltage and supply voltage; connect 0.1 $\mu$ F or greater ceramic capacitor from IN to GND as close to the device as possible.
2	DM_OUT	I/O	D– data line to USB host controller.
3	DP_OUT	I/O	D+ data line to USB host controller.
4	ILIM_SEL	I	Logic-level input signal used to control the charging mode, current limit threshold, and load detection; see <a href="#">Table 3</a> . Can be tied directly to IN or GND without pullup or pulldown resistor.
5	EN	I	Logic-level input for turning the power switch and the signal switches on/off; logic low turns off the signal and power switches and holds OUT in discharge. Can be tied directly to IN or GND without pullup or pulldown resistor.
6	CTL1	I	Logic-level input used to control the charging mode and the signal switches; see <a href="#">Table 3</a> . Can be tied directly to IN or GND without pullup or pulldown resistor.
7	CTL2	I	Logic-level input used to control the charging mode and the signal switches; see <a href="#">Table 3</a> . Can be tied directly to IN or GND without pullup or pulldown resistor.
8	CTL3	I	Logic-level input used to control the charging mode and the signal switches; see <a href="#">Table 3</a> . Can be tied directly to IN or GND without pullup or pulldown resistor.
9	$\overline{\text{STATUS}}$	O	Active-low open-drain output, asserted in load detection conditions.
10	DP_IN	I/O	D+ data line to downstream connector.
11	DM_IN	I/O	D– data line to downstream connector.
12	OUT	P	Power-switch output.
13	$\overline{\text{FAULT}}$	O	Active-low open-drain output, asserted during overtemperature or current limit conditions.
14	GND	P	Ground connection.
15	ILIM_LO	I	External resistor connection used to set the low current-limit threshold and the load detection current threshold. A resistor to ILIM_LO is optional; see <i>Current-Limit Settings</i> in <a href="#">Detailed Description</a> .
16	ILIM_HI	I	External resistor connection used to set the high-current-limit threshold.
—	Thermal Pad	—	Internally connected to GND; used to heatsink the part to the circuit board traces. Connect to GND plane.

(1) G = ground, I = input, O = output, P = power.

## 6 Specifications

### 6.1 Absolute Maximum Ratings

Over operating free-air temperature range (unless otherwise noted)<sup>(1)</sup>

		MIN	MAX	UNIT
Voltage	IN, EN, ILIM_LO, ILIM_HI, $\overline{\text{FAULT}}$ , $\overline{\text{STATUS}}$ , ILIM_SEL, CTL1, CTL2, CTL3, OUT	-0.3	7	V
	IN to OUT	-7	7	
	DP_IN, DM_IN, DP_OUT, DM_OUT	-0.3	(IN + 0.3) or 5.7	
Input clamp current	DP_IN, DM_IN, DP_OUT, DM_OUT		±20	mA
Continuous current in SDP or CDP mode	DP_IN to DP_OUT or DM_IN to DM_OUT		±100	mA
Continuous current in BC1.2 DCP mode	DP_IN to DM_IN		±50	mA
Continuous output current	OUT		Internally limited	
Continuous output sink current	$\overline{\text{FAULT}}$ , $\overline{\text{STATUS}}$		25	mA
Continuous output source current	ILIM_LO, ILIM_HI		Internally limited	mA
Operating junction temperature, T <sub>J</sub>		-40	Internally limited	°C

(1) Stresses beyond those listed under *Absolute Maximum Ratings* may cause permanent damage to the device. These are stress ratings only, which do not imply functional operation of the device at these or any other conditions beyond those indicated under *Recommended Operating Conditions*. Exposure to absolute-maximum-rated conditions for extended periods may affect device reliability.

### 6.2 ESD Ratings

			VALUE	UNIT	
V <sub>(ESD)</sub>	Electrostatic discharge	Human-body model (HBM), per ANSI/ESDA/JEDEC JS-001 <sup>(1)</sup>	HBM	±2000	V
			HBM wrt GND and each other, DP_IN, DM_IN, OUT	±8000	
		Charged-device model (CDM), per JEDEC specification JESD22-C101 <sup>(2)</sup>		±500	

(1) JEDEC document JEP155 states that 500-V HBM allows safe manufacturing with a standard ESD control process.

(2) JEDEC document JEP157 states that 250-V CDM allows safe manufacturing with a standard ESD control process.

### 6.3 Recommended Operating Conditions

voltages are referenced to GND (unless otherwise noted)

		MIN	MAX	UNIT	
V <sub>IN</sub>	Input voltage, IN	4.5	5.5	V	
	Input voltage, logic-level inputs, EN, CTL1, CTL2, CTL3, ILIM_SEL	0	5.5	V	
	Input voltage, data line inputs, DP_IN, DM_IN, DP_OUT, DM_OUT	0	V <sub>IN</sub>	V	
V <sub>IH</sub>	High-level input voltage, EN, CTL1, CTL2, CTL3, ILIM_SEL	1.8		V	
V <sub>IL</sub>	Low-level input voltage, EN, CTL1, CTL2, CTL3, ILIM_SEL		0.8	V	
	Continuous current, data line inputs, SDP or CDP mode, DP_IN to DP_OUT, DM_IN to DM_OUT		±30	mA	
	Continuous current, data line inputs, BC1.2 DCP mode, DP_IN to DM_IN		±15	mA	
I <sub>OUT</sub>	Continuous output current, OUT	T <sub>J</sub> = -40°C to 125°C	0	2.5	A
		T <sub>J</sub> = -40°C to 115°C	0	3.0	
	Continuous output sink current, $\overline{\text{FAULT}}$ , $\overline{\text{STATUS}}$	0	10	mA	
R <sub>ILIM_XX</sub>	Current-limit set resistors	15.4	750	kΩ	
T <sub>J</sub>	Operating virtual junction temperature	-40	125	°C	

## 6.4 Thermal Information

THERMAL METRIC <sup>(1)</sup>		TPS2547	UNIT
		RTE (WQFN)	
		16 PINS	
R <sub>θJA</sub>	Junction-to-ambient thermal resistance	53.4	°C/W
R <sub>θJC(top)</sub>	Junction-to-case (top) thermal resistance	51.4	°C/W
R <sub>θJB</sub>	Junction-to-board thermal resistance	17.2	°C/W
ψ <sub>JT</sub>	Junction-to-top characterization parameter	3.7	°C/W
ψ <sub>JB</sub>	Junction-to-board characterization parameter	20.7	°C/W
R <sub>θJC(bot)</sub>	Junction-to-case (bottom) thermal resistance	3.9	°C/W

(1) For more information about traditional and new thermal metrics, see the [Semiconductor and IC Package Thermal Metrics](#) application report.

## 6.5 Electrical Characteristics

Unless otherwise noted:  $-40 \leq T_J \leq 125^\circ\text{C}$ ,  $4.5 \text{ V} \leq V_{\text{IN}} \leq 5.5 \text{ V}$ ,  $V_{\text{EN}} = V_{\text{IN}}$ ,  $V_{\text{ILIM\_SEL}} = V_{\text{IN}}$ ,  $V_{\text{CTL1}} = V_{\text{CTL2}} = V_{\text{CTL3}} = V_{\text{IN}}$ .  $R_{\text{FAULT}} = R_{\text{STATUS}} = 10 \text{ k}\Omega$ ,  $R_{\text{ILIM\_HI}} = 20 \text{ k}\Omega$ ,  $R_{\text{ILIM\_LO}} = 80.6 \text{ k}\Omega$ . Positive currents are into pins. Typical values are at  $25^\circ\text{C}$ . All voltages are with respect to GND.

PARAMETER		TEST CONDITIONS	MIN	TYP	MAX	UNIT
<b>POWER SWITCH</b>						
R <sub>DS(on)</sub>	ON resistance <sup>(1)</sup>	T <sub>J</sub> = 25°C, I <sub>OUT</sub> = 2 A		73	84	mΩ
		-40°C ≤ T <sub>J</sub> ≤ 85°C, I <sub>OUT</sub> = 2 A		73	105	
		-40°C ≤ T <sub>J</sub> ≤ 125°C, I <sub>OUT</sub> = 2 A		73	120	
t <sub>r</sub>	OUT voltage rise time	V <sub>IN</sub> = 5 V, C <sub>L</sub> = 1 μF, R <sub>L</sub> = 100 Ω (see <a href="#">Figure 23</a> and <a href="#">Figure 24</a> )	0.7	1	1.6	ms
t <sub>f</sub>	OUT voltage fall time		0.2	0.35	0.5	
t <sub>on</sub>	OUT voltage turnon time	V <sub>IN</sub> = 5 V, C <sub>L</sub> = 1 μF, R <sub>L</sub> = 100 Ω (see <a href="#">Figure 23</a> and <a href="#">Figure 25</a> )		2.7	4	ms
t <sub>off</sub>	OUT voltage turnoff time			1.7	3	
I <sub>REV</sub>	Reverse leakage current	V <sub>OUT</sub> = 5.5 V, V <sub>IN</sub> = V <sub>EN</sub> = 0 V, -40 ≤ T <sub>J</sub> ≤ 85°C, Measure I <sub>OUT</sub>			2	μA
<b>DISCHARGE</b>						
R <sub>DCHG</sub>	OUT discharge resistance		400	500	630	Ω
t <sub>DCHG_L</sub>	Long OUT discharge hold time	Time V <sub>OUT</sub> < 0.7 V (see <a href="#">Figure 26</a> )	1.3	2	2.9	s
t <sub>DCHG_S</sub>	Short OUT discharge hold time	Time V <sub>OUT</sub> < 0.7 V (see <a href="#">Figure 26</a> )	205	310	450	ms
<b>EN, ILIMSEL, CTL1, CTL2, CTL3 INPUTS</b>						
	Input pin rising logic threshold voltage		1	1.35	1.7	V
	Input pin falling logic threshold voltage		0.85	1.15	1.45	
	Hysteresis <sup>(2)</sup>			200		mV
	Input current	Pin voltage = 0 V or 5.5 V	-0.5		0.5	μA
<b>ILIMSEL CURRENT LIMIT</b>						
I <sub>OS</sub>	OUT short-circuit current limit <sup>(1)</sup>	V <sub>ILIM_SEL</sub> = 0 V, R <sub>ILIM_LO</sub> = 210 kΩ	213	250	287	mA
		V <sub>ILIM_SEL</sub> = 0 V, R <sub>ILIM_LO</sub> = 80.6 kΩ	598	650	708	
		V <sub>ILIM_SEL</sub> = 0 V, R <sub>ILIM_LO</sub> = 22.1 kΩ	2200	2365	2530	
		V <sub>ILIM_SEL</sub> = V <sub>IN</sub> , R <sub>ILIM_HI</sub> = 20 kΩ	2425	2610	2800	
		V <sub>ILIM_SEL</sub> = V <sub>IN</sub> , R <sub>ILIM_HI</sub> = 16.9 kΩ	2875	3085	3300	
		V <sub>ILIM_SEL</sub> = V <sub>IN</sub> , R <sub>ILIM_HI</sub> = 15.4 kΩ, T <sub>J</sub> = -40°C to 115°C	3150	3375	3600	
t <sub>iOS</sub>	Response time to OUT short-circuit <sup>(2)</sup>	V <sub>IN</sub> = 5 V, R = 0.1Ω, lead length = 2 inches (see <a href="#">Figure 27</a> )		1.5		μs

(1) Pulse-testing techniques maintain junction temperature close to ambient temperature; Thermal effects must be taken into account separately.

(2) These parameters are provided for reference only and do not constitute part of TI's published device specifications for purposes of TI's product warranty.

## Electrical Characteristics (continued)

Unless otherwise noted:  $-40 \leq T_J \leq 125^\circ\text{C}$ ,  $4.5 \text{ V} \leq V_{IN} \leq 5.5 \text{ V}$ ,  $V_{EN} = V_{IN}$ ,  $V_{ILIM\_SEL} = V_{IN}$ ,  $V_{CTL1} = V_{CTL2} = V_{CTL3} = V_{IN}$ .  $R_{\overline{\text{FAULT}}} = R_{\overline{\text{STATUS}}} = 10 \text{ k}\Omega$ ,  $R_{ILIM\_HI} = 20 \text{ k}\Omega$ ,  $R_{ILIM\_LO} = 80.6 \text{ k}\Omega$ . Positive currents are into pins. Typical values are at  $25^\circ\text{C}$ . All voltages are with respect to GND.

PARAMETER		TEST CONDITIONS	MIN	TYP	MAX	UNIT
<b>SUPPLY CURRENT</b>						
$I_{IN\_OFF}$	Disabled IN supply current	$V_{EN} = 0 \text{ V}$ , $V_{OUT} = 0 \text{ V}$ , $-40 \leq T_J \leq 85^\circ\text{C}$		0.1	2	$\mu\text{A}$
$I_{IN\_ON}$	Enabled IN supply current	$V_{CTL1} = V_{CTL2} = V_{IN}$ , $V_{CTL3} = 0 \text{ V}$ , $V_{ILIM\_SEL} = 0 \text{ V}$		165	220	$\mu\text{A}$
		$V_{CTL1} = V_{CTL2} = V_{CTL3} = V_{IN}$ , $V_{ILIM\_SEL} = 0 \text{ V}$		175	230	
		$V_{CTL1} = V_{CTL2} = V_{IN}$ , $V_{CTL3} = 0 \text{ V}$ , $V_{ILIM\_SEL} = V_{IN}$		185	240	
		$V_{CTL1} = V_{CTL2} = V_{IN}$ , $V_{CTL3} = V_{IN}$ , $V_{ILIM\_SEL} = V_{IN}$		195	250	
		$V_{CTL1} = 0 \text{ V}$ , $V_{CTL2} = V_{CTL3} = V_{IN}$		215	270	
<b>UNDERVOLTAGE LOCKOUT</b>						
$V_{UVLO}$	IN rising UVLO threshold voltage		3.9	4.1	4.3	V
	Hysteresis <sup>(2)</sup>			100		mV
<b>FAULT</b>						
	Output low voltage	$I_{\overline{\text{FAULT}}} = 1 \text{ mA}$			100	mV
	OFF-state leakage	$V_{\overline{\text{FAULT}}} = 5.5 \text{ V}$			1	$\mu\text{A}$
	Overcurrent $\overline{\text{FAULT}}$ rising and falling deglitch		5	8.2	12	ms
<b>STATUS</b>						
	Output low voltage	$I_{\overline{\text{STATUS}}} = 1 \text{ mA}$			100	mV
	OFF-state leakage	$V_{\overline{\text{STATUS}}} = 5.5 \text{ V}$			1	$\mu\text{A}$
<b>THERMAL SHUTDOWN</b>						
	Thermal shutdown threshold		155			$^\circ\text{C}$
	Thermal shutdown threshold in current-limit		135			
	Hysteresis <sup>(2)</sup>			20		

## 6.6 Electrical Characteristics: High-Bandwidth Switch

Unless otherwise noted:  $-40 \leq T_J \leq 125^\circ\text{C}$ ,  $4.5 \text{ V} \leq V_{IN} \leq 5.5 \text{ V}$ ,  $V_{EN} = V_{IN}$ ,  $V_{ILIM\_SEL} = V_{IN}$ ,  $V_{CTL1} = V_{CTL2} = V_{CTL3} = V_{IN}$ .  $R_{\overline{\text{FAULT}}} = R_{\overline{\text{STATUS}}} = 10 \text{ k}\Omega$ ,  $R_{ILIM\_HI} = 20 \text{ k}\Omega$ ,  $R_{ILIM\_LO} = 80.6 \text{ k}\Omega$ . Positive currents are into pins. Typical values are at  $25^\circ\text{C}$ . All voltages are with respect to GND.

PARAMETER		TEST CONDITIONS	MIN	TYP	MAX	UNIT
<b>HIGH-BANDWIDTH ANALOG SWITCH</b>						
DP/DM switch ON resistance		$V_{DP/DM\_OUT} = 0 \text{ V}$ , $I_{DP/DM\_IN} = 30 \text{ mA}$		2	4	$\Omega$
		$V_{DP/DM\_OUT} = 2.4 \text{ V}$ , $I_{DP/DM\_IN} = -15 \text{ mA}$		3	6	
Switch resistance mismatch between DP / DM channels		$V_{DP/DM\_OUT} = 0 \text{ V}$ , $I_{DP/DM\_IN} = 30 \text{ mA}$		0.05	0.15	$\Omega$
		$V_{DP/DM\_OUT} = 2.4 \text{ V}$ , $I_{DP/DM\_IN} = -15 \text{ mA}$		0.05	0.15	
DP/DM switch OFF-state capacitance <sup>(1)</sup>		$V_{EN} = 0 \text{ V}$ , $V_{DP/DM\_IN} = 0.3 \text{ V}$ , $V_{ac} = 0.6 \text{ V}_{pk-pk}$ , $f = 1 \text{ MHz}$		3	3.6	pF
DP/DM switch ON-state capacitance <sup>(2)</sup>		$V_{DP/DM\_IN} = 0.3 \text{ V}$ , $V_{ac} = 0.6 \text{ V}_{pk-pk}$ , $f = 1 \text{ MHz}$		5.4	6.2	pF
$O_{IRR}$	OFF-state isolation <sup>(3)</sup>	$V_{EN} = 0 \text{ V}$ , $f = 250 \text{ MHz}$		33		dB
$X_{TALK}$	ON-state cross channel isolation <sup>(3)</sup>	$f = 250 \text{ MHz}$		52		dB
	OFF-state leakage current	$V_{EN} = 0 \text{ V}$ , $V_{DP/DM\_IN} = 3.6 \text{ V}$ , $V_{DP/DM\_OUT} = 0 \text{ V}$ , measure $I_{DP/DM\_OUT}$		0.1	1.5	$\mu\text{A}$
BW	Bandwidth ( $-3 \text{ dB}$ ) <sup>(3)</sup>	$R_L = 50 \Omega$		2.6		GHz
$t_{pd}$	Propagation delay <sup>(3)</sup>			0.25		ns

(1) The resistance in series with the parasitic capacitance to GND is typically  $250 \Omega$ .

(2) The resistance in series with the parasitic capacitance to GND is typically  $150 \Omega$ .

(3) These parameters are provided for reference only and do not constitute part of TI's published device specifications for purposes of TI's product warranty.

## Electrical Characteristics: High-Bandwidth Switch (continued)

Unless otherwise noted:  $-40 \leq T_J \leq 125^\circ\text{C}$ ,  $4.5 \text{ V} \leq V_{\text{IN}} \leq 5.5 \text{ V}$ ,  $V_{\text{EN}} = V_{\text{IN}}$ ,  $V_{\text{ILIM\_SEL}} = V_{\text{IN}}$ ,  $V_{\text{CTL1}} = V_{\text{CTL2}} = V_{\text{CTL3}} = V_{\text{IN}}$ .  $R_{\text{FAULT}} = R_{\text{STATUS}} = 10 \text{ k}\Omega$ ,  $R_{\text{ILIM\_HI}} = 20 \text{ k}\Omega$ ,  $R_{\text{ILIM\_LO}} = 80.6 \text{ k}\Omega$ . Positive currents are into pins. Typical values are at  $25^\circ\text{C}$ . All voltages are with respect to GND.

PARAMETER	TEST CONDITIONS	MIN	TYP	MAX	UNIT
$t_{\text{SK}}$	Skew between opposite transitions of the same port ( $t_{\text{PHL}} - t_{\text{PLH}}$ )		0.1	0.2	ns

## 6.7 Electrical Characteristics: Charging Controller

Unless otherwise noted:  $-40 \leq T_J \leq 125^\circ\text{C}$ ,  $4.5 \text{ V} \leq V_{\text{IN}} \leq 5.5 \text{ V}$ ,  $V_{\text{EN}} = V_{\text{IN}}$ ,  $V_{\text{ILIM\_SEL}} = V_{\text{IN}}$ ,  $V_{\text{CTL1}} = 0 \text{ V}$ ,  $V_{\text{CTL2}} = V_{\text{CTL3}} = V_{\text{IN}}$ .  $R_{\text{FAULT}} = R_{\text{STATUS}} = 10 \text{ k}\Omega$ ,  $R_{\text{ILIM\_HI}} = 20 \text{ k}\Omega$ ,  $R_{\text{ILIM\_LO}} = 80.6 \text{ k}\Omega$ . Positive currents are into pins. Typical values are at  $25^\circ\text{C}$ . All voltages are with respect to GND.

PARAMETER	TEST CONDITIONS	MIN	TYP	MAX	UNIT		
<b>SHORTED MODE (BC1.2 DCP)</b>							
DP_IN / DM_IN shorting resistance	$V_{\text{CTL1}} = V_{\text{IN}}$ , $V_{\text{CTL2}} = V_{\text{CTL3}} = 0 \text{ V}$		125	200	$\Omega$		
<b>1.2 V MODE</b>							
DP_IN /DM_IN output voltage	$V_{\text{CTL1}} = V_{\text{IN}}$ , $V_{\text{CTL2}} = V_{\text{CTL3}} = 0 \text{ V}$	1.19	1.25	1.31	V		
DP_IN /DM_IN output impedance		60	75	94	k $\Omega$		
<b>DIVIDER1 MODE</b>							
DP_IN divider1 output voltage	$V_{\text{CTL1}} = V_{\text{IN}}$ , $V_{\text{CTL2}} = V_{\text{CTL3}} = 0 \text{ V}$	1.9	2	2.1	V		
DM_IN divider1 output voltage		2.57	2.7	2.84	V		
DP_IN output impedance		8	10.5	12.5	k $\Omega$		
DM_IN output impedance		8	10.5	12.5	k $\Omega$		
<b>DIVIDER2 MODE</b>							
DP_IN divider2 output voltage	IOUT = 1 A	2.57	2.7	2.84	V		
DM_IN divider2 output voltage		1.9	2	2.1	V		
DP_IN output impedance		8	10.5	12.5	k $\Omega$		
DM_IN output impedance		8	10.5	12.5	k $\Omega$		
<b>CHARGING DOWNSTREAM PORT</b>							
$V_{\text{DM\_SRC}}$	DM_IN CDP output voltage	$V_{\text{CTL1}} = V_{\text{CTL2}} = V_{\text{CTL3}} = V_{\text{IN}}$	$V_{\text{DP\_IN}} = 0.6 \text{ V}$ , $-250 \mu\text{A} < I_{\text{DM\_IN}} < 0 \mu\text{A}$	0.5	0.6	0.7	V
$V_{\text{DAT\_REF}}$	DP_IN rising lower window threshold for $V_{\text{DM\_SRC}}$ activation	$V_{\text{CTL1}} = V_{\text{CTL2}} = V_{\text{CTL3}} = V_{\text{IN}}$		0.25		0.4	V
	Hysteresis <sup>(1)</sup>				50	mV	
$V_{\text{LGC\_SRC}}$	DP_IN rising upper window threshold for $V_{\text{DM\_SRC}}$ de-activation			0.8		1	V
	Hysteresis <sup>(1)</sup>				100	mV	
$I_{\text{DP\_SINK}}$	DP_IN sink current	$V_{\text{CTL1}} = V_{\text{CTL2}} = V_{\text{CTL3}} = V_{\text{IN}}$	$V_{\text{DP\_IN}} = 0.6 \text{ V}$	40	70	100	$\mu\text{A}$
<b>LOAD DETECT – NON-POWER WAKE</b>							
$I_{\text{LD}}$	IOUT rising load detect current threshold	$V_{\text{CTL1}} = V_{\text{CTL2}} = V_{\text{CTL3}} = V_{\text{IN}}$		635	700	765	mA
	Hysteresis <sup>(1)</sup>				50	mA	
$t_{\text{LD\_SET}}$	Load detect set time			140	200	275	ms
	Load detect reset time			1.9	3	4.2	s

(1) These parameters are provided for reference only and do not constitute part of Texas Instrument's published device specifications for purposes of Texas Instrument's product warranty.

**Electrical Characteristics: Charging Controller (continued)**

Unless otherwise noted:  $-40 \leq T_J \leq 125^\circ\text{C}$ ,  $4.5 \text{ V} \leq V_{\text{IN}} \leq 5.5 \text{ V}$ ,  $V_{\text{EN}} = V_{\text{IN}}$ ,  $V_{\text{ILIM\_SEL}} = V_{\text{IN}}$ ,  $V_{\text{CTL1}} = 0 \text{ V}$ ,  $V_{\text{CTL2}} = V_{\text{CTL3}} = V_{\text{IN}}$ .  $R_{\text{FAULT}} = R_{\text{STATUS}} = 10 \text{ k}\Omega$ ,  $R_{\text{ILIM\_HI}} = 20 \text{ k}\Omega$ ,  $R_{\text{ILIM\_LO}} = 80.6 \text{ k}\Omega$ . Positive currents are into pins. Typical values are at  $25^\circ\text{C}$ . All voltages are with respect to GND.

PARAMETER		TEST CONDITIONS	MIN	TYP	MAX	UNIT
<b>LOAD DETECT – POWER WAKE</b>						
$I_{\text{OS\_PW}}$	Power wake short-circuit current limit	$V_{\text{CTL1}} = V_{\text{CTL2}} = 0 \text{ V}$ , $V_{\text{CTL3}} = V_{\text{IN}}$	32	55	78	mA
	$I_{\text{OUT}}$ falling power wake reset current detection threshold		23	45	67	mA
	Reset current hysteresis <sup>(1)</sup>			5		mA
	Power wake reset time		10.7	15	20.6	s

### 6.8 Typical Characteristics

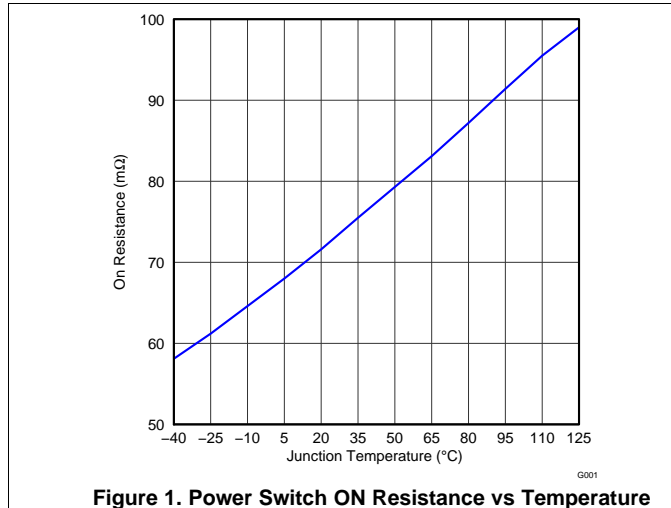

Figure 1. Power Switch ON Resistance vs Temperature

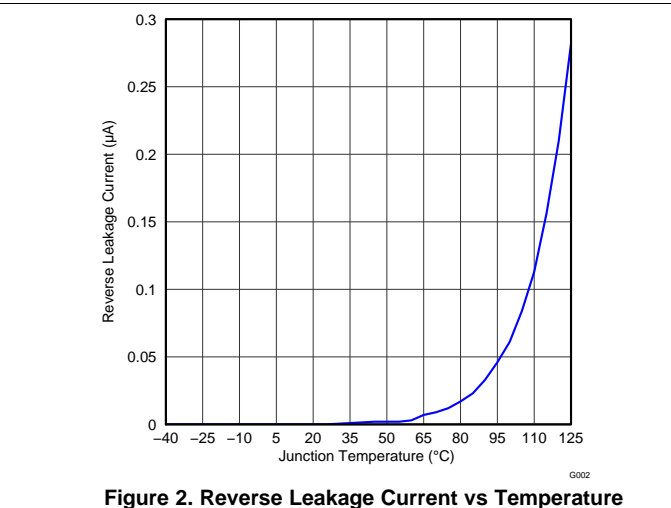

Figure 2. Reverse Leakage Current vs Temperature

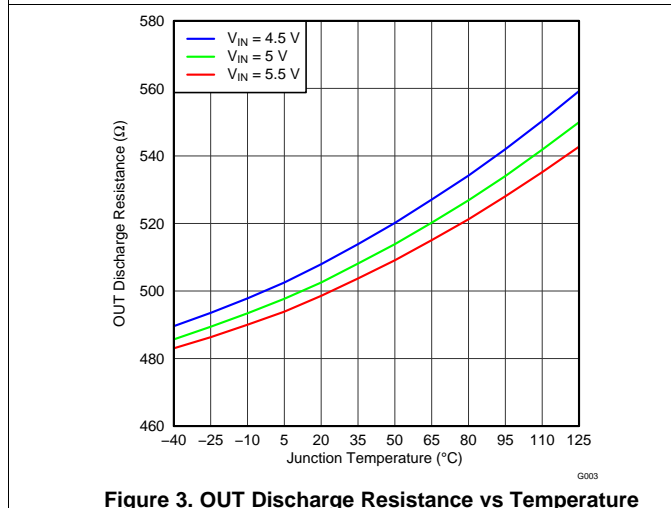

Figure 3. OUT Discharge Resistance vs Temperature

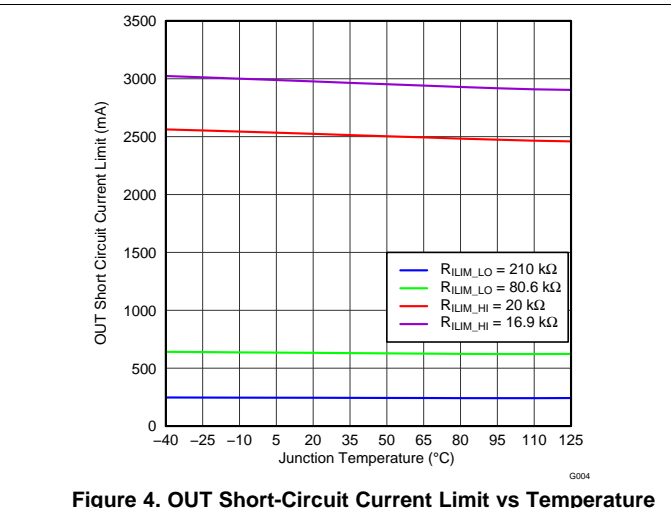

Figure 4. OUT Short-Circuit Current Limit vs Temperature

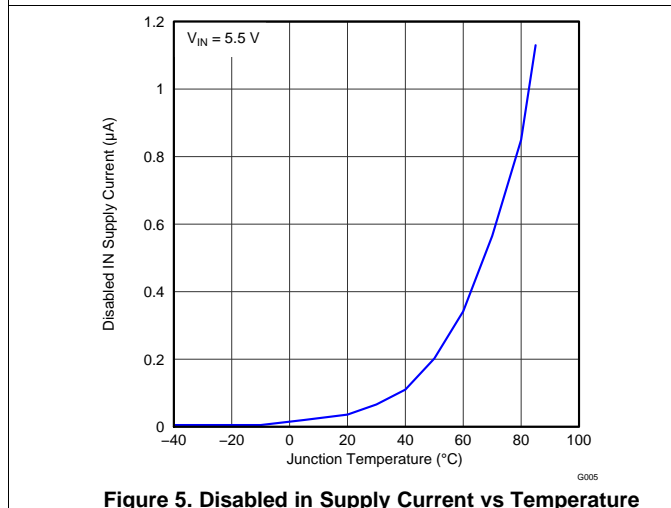

Figure 5. Disabled in Supply Current vs Temperature

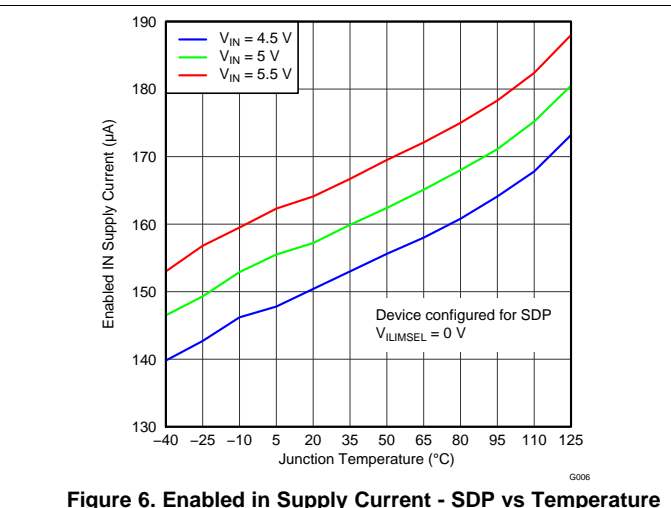

Figure 6. Enabled in Supply Current - SDP vs Temperature

Typical Characteristics (continued)

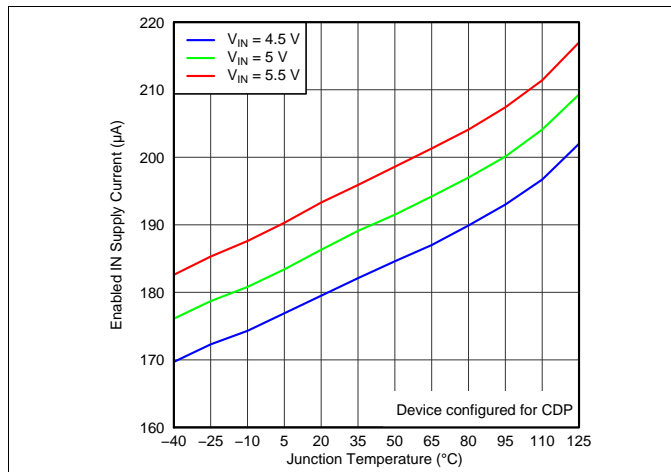

Figure 7. Enabled in Supply Current - CDP vs Temperature

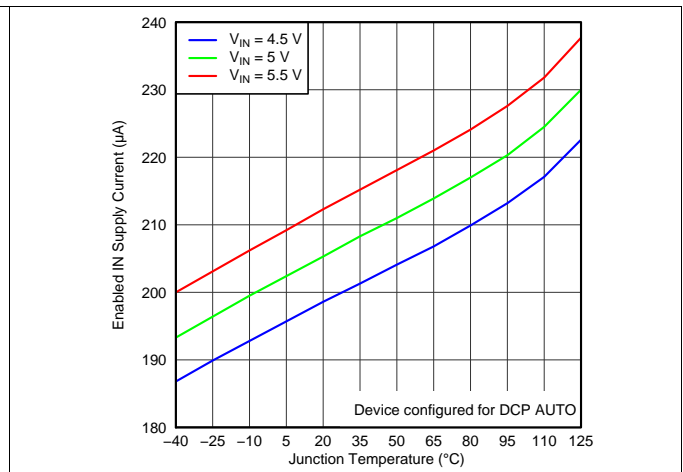

Figure 8. Enabled in Supply Current - DCP Auto vs Temperature

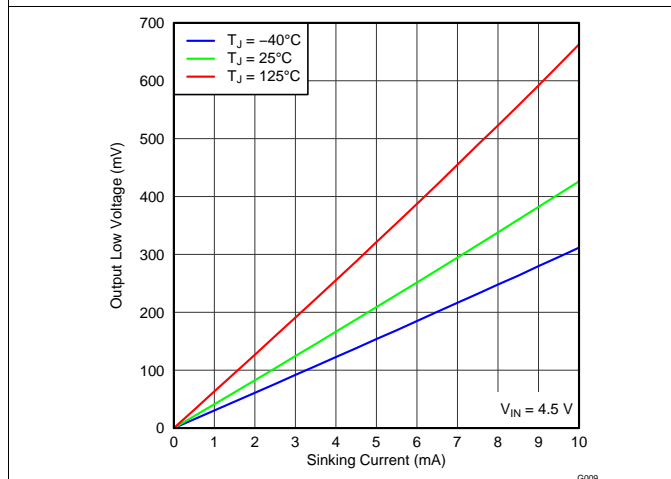

Figure 9. Status and Fault Output Low Voltage vs Sinking Current

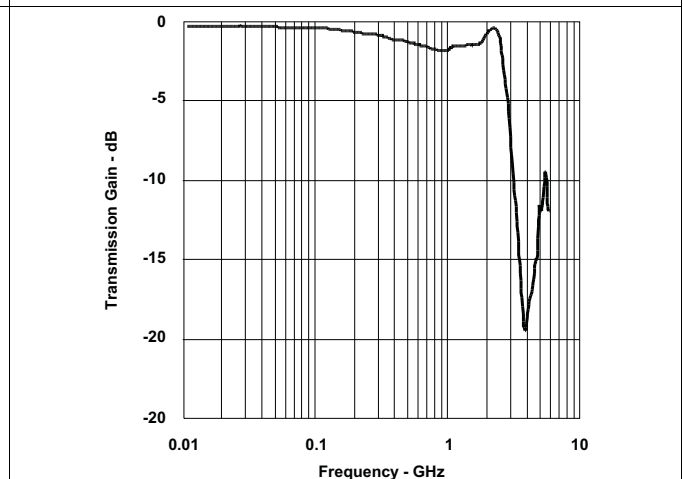

Figure 10. Data Transmission Characteristics vs Frequency

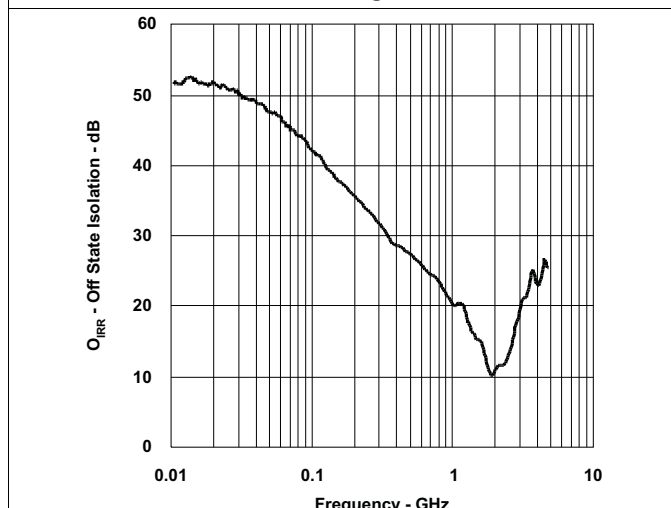

Figure 11. OFF-State Data Switch Isolation vs Frequency

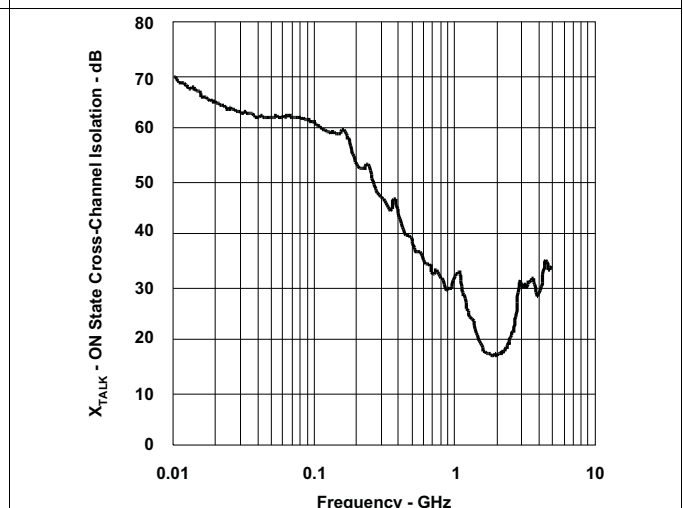

Figure 12. ON-State Cross-Channel Isolation vs Frequency

Typical Characteristics (continued)

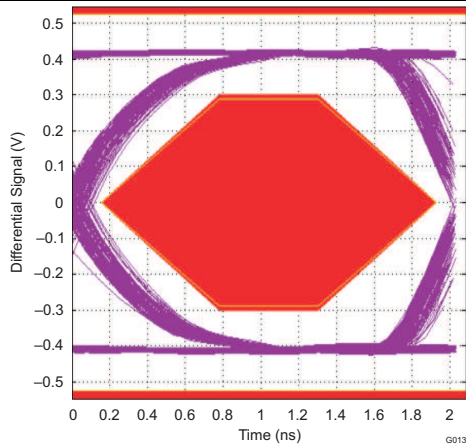

Figure 13. Eye Diagram Using USB Compliance Test Pattern (With No Switch)

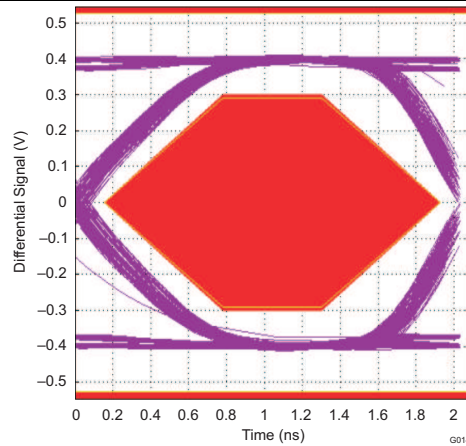

Figure 14. Eye Diagram Using USB Compliance Test Pattern (With Data Switch)

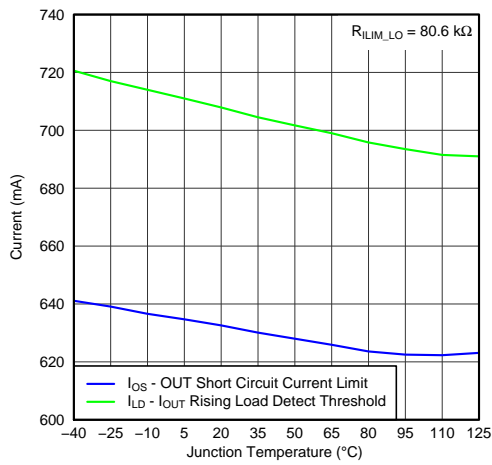

Figure 15. IOUTrising Load Detect Threshold and Out Short-Circuit Current Limit vs Temperature

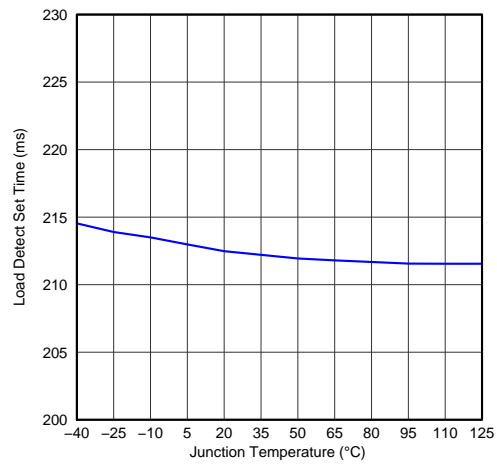

Figure 16. Load Detect Set Time vs Temperature

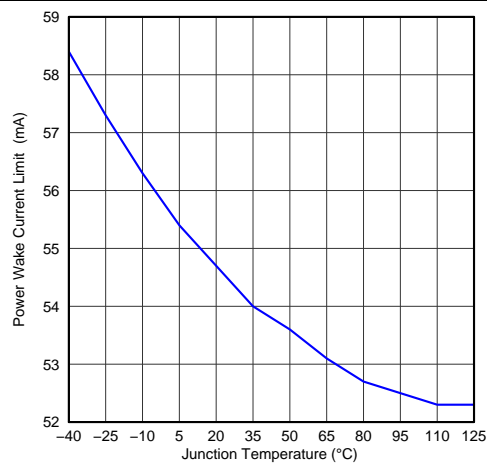

Figure 17. Power Wake Current Limit vs Temperature

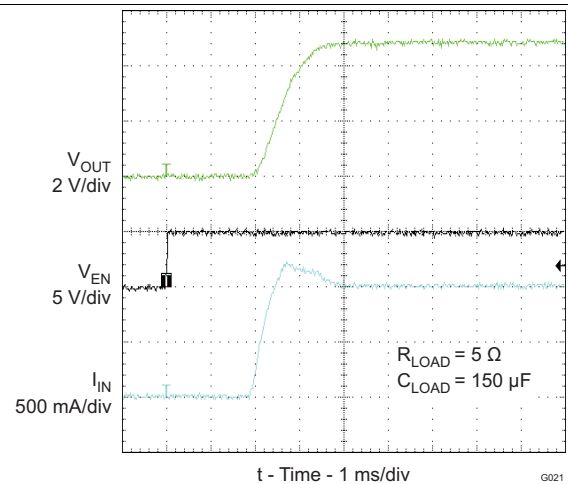

Figure 18. Turnon Response

Typical Characteristics (continued)

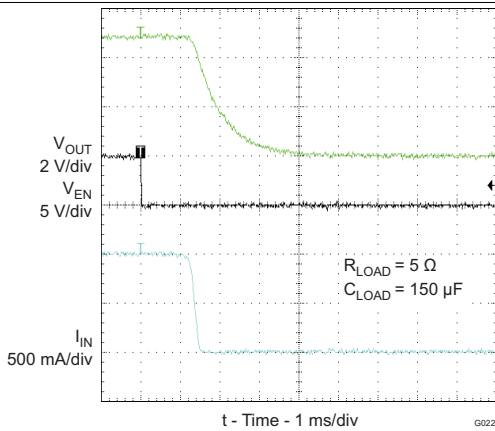

Figure 19. Turnoff Response

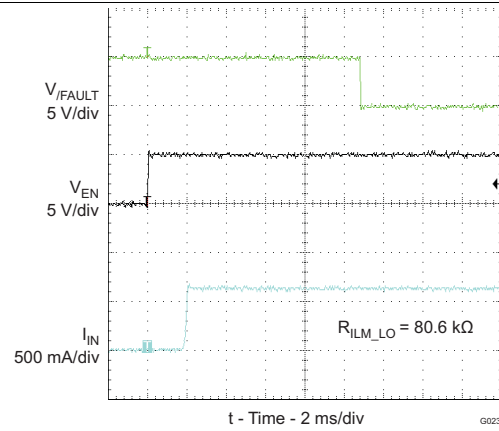

Figure 20. Device Enabled Into Short-Circuit

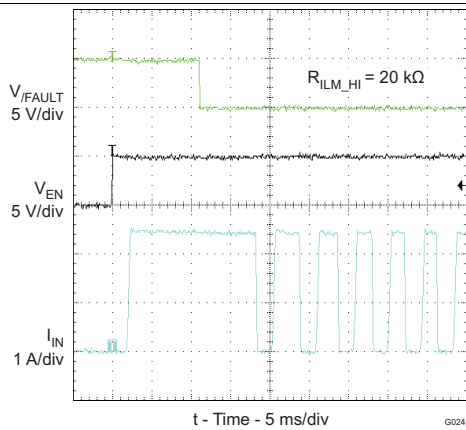

Figure 21. Device Enabled Into Short-Circuit - Thermal Cycling

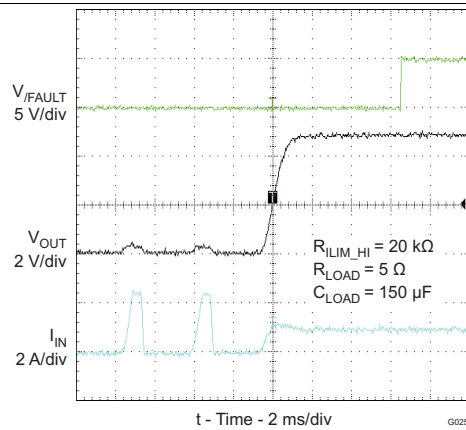

Figure 22. Short-Circuit to Full Load Recovery

## 7 Parameter Measurement Information

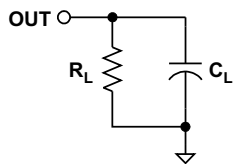

Figure 23. Out Rise/Fall Test Load

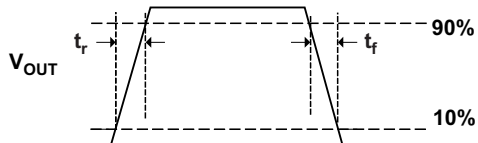

Figure 24. Power-ON and OFF Timing

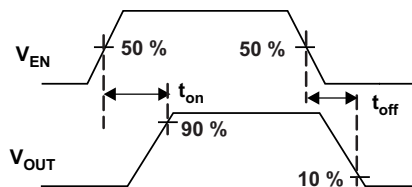

Figure 25. Enable Timing, Active High Enable

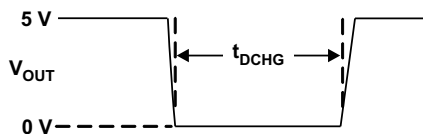

Figure 26. Out Discharge During Mode Change

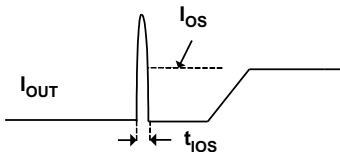

Figure 27. Output Short-Circuit Parameters

## 8 Detailed Description

### 8.1 Overview

The following overview references various industry standards. TI recommends consulting the most up-to-date standard to ensure the most recent and accurate information. Rechargeable portable equipment requires an external power source to charge its batteries. USB ports are a convenient location for charging, because of an available 5-V power source. Universally accepted standards are required to make sure host and client-side devices operate together in a system to ensure power management requirements are met. Traditionally, host ports following the USB 2.0 specification must provide at least 500 mA to downstream client-side devices. Because multiple USB devices can attach to a single USB port through a bus-powered hub, it is the responsibility of the client-side device to negotiate its power allotment from the host, ensuring the total current draw does not exceed 500 mA. In general, each USB device is granted 100 mA, and may request more current in 100-mA unit steps up to 500 mA. The host may grant or deny based on the available current. A USB 3.0 host port not only provides higher data rate than USB 2.0 port, but also raises the unit load from 100 mA to 150 mA. It is also required to provide a minimum current of 900 mA to downstream client-side devices.

Additionally, the success of USB makes the mini-USB connector a popular choice for wall adapter cables. This allows a portable device to charge from both a wall adapter, and USB port with only one connector. As USB charging has gained popularity, the 500-mA minimum defined by USB 2.0 or 900 mA for USB 3.0 has become insufficient for many handset and personal media players, which need a higher charging rate. Wall adapters can provide much more current than 500 mA/900 mA. Several new standards have been introduced, defining protocol handshaking methods that allow host and client devices to acknowledge and draw additional current beyond the 500 mA/900 mA minimum defined by USB 2.0 and 3.0, while still using a single micro-USB input connector.

The TPS2547 supports four of the most common USB charging schemes found in popular handheld media and cellular devices:

- USB Battery Charging Specification BC1.2
- Chinese Telecommunications Industry Standard YD/T 1591-2009
- Divider Mode
- 1.2-V Mode

YD/T 1591-2009 is a subset of BC1.2 specifications supported by vast majority of devices that implement USB charging. Divider and 1.2-V charging schemes are supported in devices from specific, yet popular device makers.

BC1.2 lists three different port types:

- Standard Downstream Port (SDP)
- Charging Downstream Port (CDP)
- Dedicated Charging Port (DCP)

BC1.2 defines a charging port as a downstream facing USB port that provides power for charging portable equipment. Under this definition, CDP and DCP are defined as charging ports.

## 8.2 Functional Block Diagram

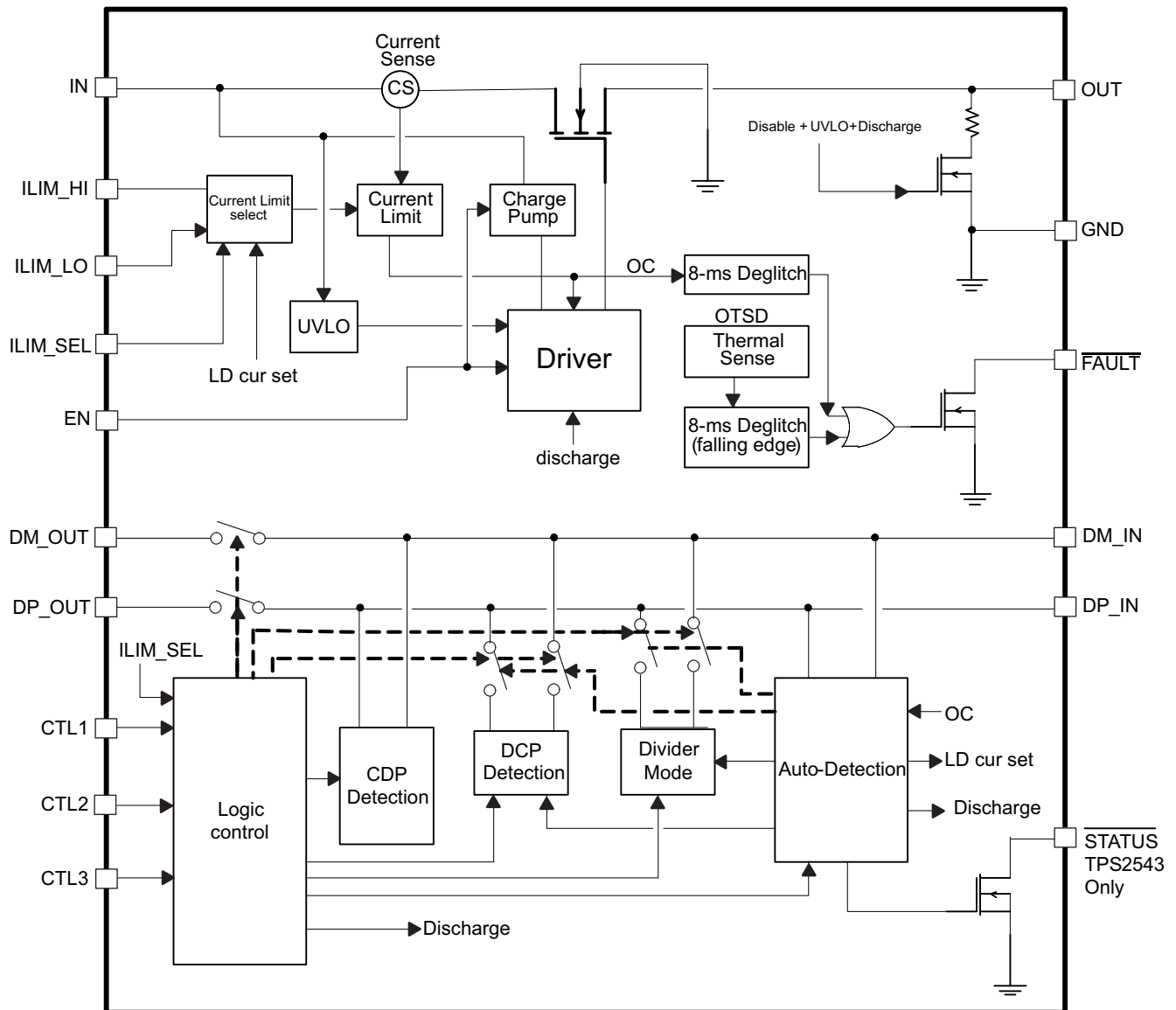

Copyright © 2016, Texas Instruments Incorporated

## 8.3 Feature Description

### 8.3.1 Standard Downstream Port (SDP) USB 2.0/USB 3.0

An SDP is a traditional USB port that follows USB 2.0 and 3.0 protocol, and supplies a minimum of 500 mA for USB 2.0 and 900 mA for USB 3.0 per port. USB 2.0 and 3.0 communications is supported, and the host controller must be active to allow charging. TPS2547 supports SDP mode in system power state S0, when system is completely powered ON, and fully operational. For more details on control pin (CTL1-CTL3) settings to program this state, see [Table 3](#).

## Feature Description (continued)

### 8.3.2 Charging Downstream Port (CDP)

A CDP is a USB port that follows USB BC1.2 and supplies a minimum of 1.5 A per port. It provides power and meets USB 2.0 requirements for device enumeration. USB 2.0 communications is supported, and the host controller must be active to allow charging. What separates a CDP from an SDP is the host-charge handshaking logic that identifies this port as a CDP. A CDP is identifiable by a compliant BC1.2 client device, and allows for additional current draw by the client device.

The CDP process is done in two steps. During step one, the portable equipment outputs a nominal 0.6-V output on the D+ line, and reads the voltage input on the D– line. The portable device detects it is connected to an SDP if the D– voltage is less than the nominal data detect voltage of 0.3 V. The portable device detects that it is connected to a Charging Port if the D– voltage is greater than the nominal data detect voltage of 0.3 V, and optionally less than 0.8 V.

The second step is necessary for portable equipment to determine if it is connected to CDP or DCP. The portable device outputs a nominal 0.6 V output on its D– line, and reads the voltage input on its D+ line. The portable device detects it is connected to a CDP if the data line being read remains less than the nominal data detect voltage of 0.3 V. The portable device detects it is connected to a DCP if the data line being read is greater than the nominal data detect voltage of 0.3 V.

TPS2547 supports CDP mode in system power state S0 when system is completely powered ON, and fully operational. For more details on control pin (CTL1-CTL3) settings to program this state, see [Table 3](#).

### 8.3.3 Dedicated Charging Port (DCP)

A DCP only provides power but does not support data connection to an upstream port. As shown in following sections, a DCP is identified by the electrical characteristics of the data lines. The TPS2547 emulates DCP in two charging states, namely DCP Forced and DCP Auto as shown in [Figure 37](#). In DCP Forced state the device supports one of the two DCP charging schemes, namely Divider1 or Shorted. In the DCP Auto state, the device charge detection state machine is activated to selectively implement charging schemes involved with the Shorted, Divider1, Divider2, and 1.2-V modes. Shorted DCP mode complies with BC1.2 and Chinese Telecommunications Industry Standard YD/T 1591-2009, while the Divider and 1.2-V modes are employed to charge devices that do not comply with BC1.2 DCP standard.

#### 8.3.3.1 DCP BC1.2 and YD/T 1591-2009

Both standards define that the D+ and D– data lines must be shorted together with a maximum series impedance of 200 Ω. This is shown in [Figure 28](#).

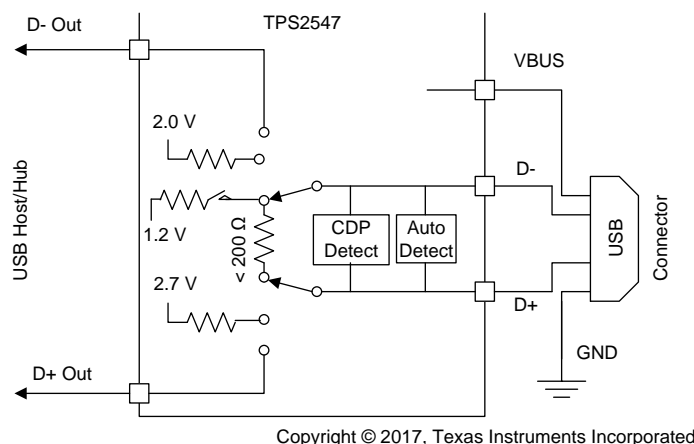

**Figure 28. DCP Supporting BC1.2/YD/T 1591-2009**

Feature Description (continued)

8.3.3.2 DCP Divider Charging Scheme

There are two Divider charging scheme supported by the device, Divider1 and Divider2 as shown in Figure 29 and Figure 30. In Divider1 charging scheme the device applies 2 V and 2.7 V to D+ and D- data line respectively. This is reversed in Divider2 mode.

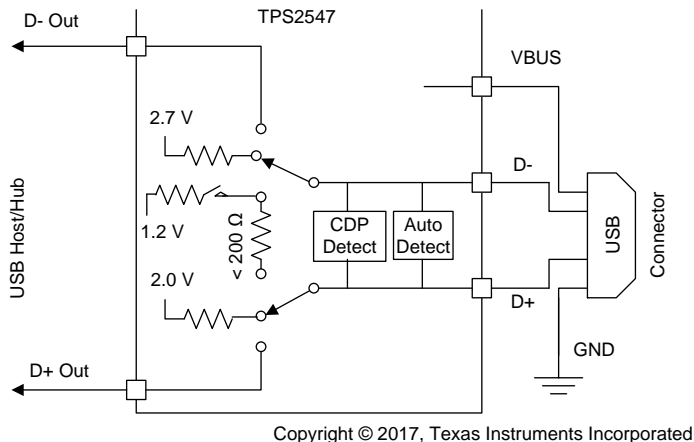

Figure 29. DCP Divider1 Charging Scheme

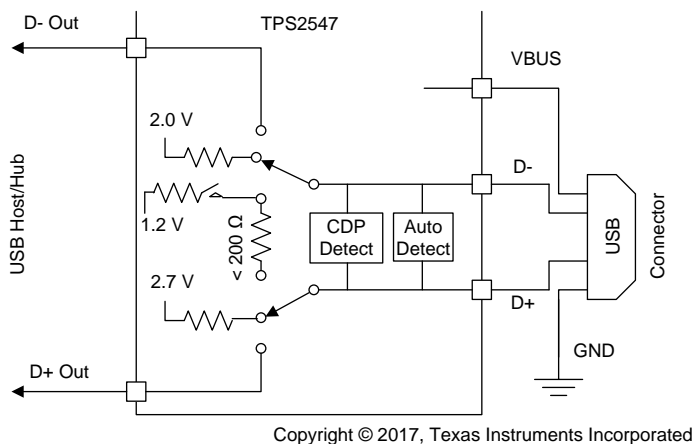
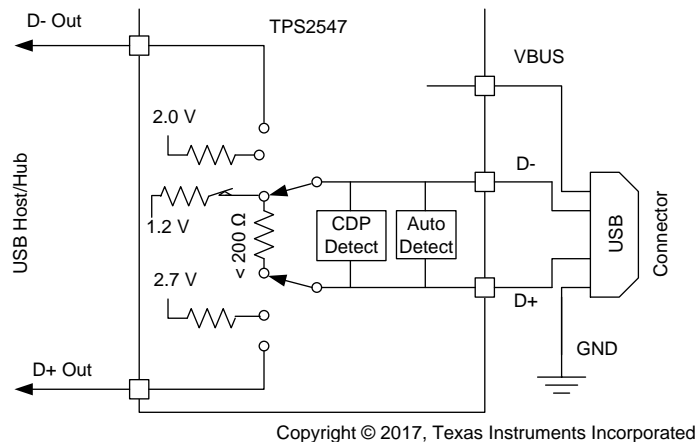

Figure 30. Divider2 Charging Scheme

## Feature Description (continued)

### 8.3.3.3 DCP 1.2-V Charging Scheme

1.2-V charging scheme is used by some handheld devices to enable fast charging at 2 A. TPS2547 supports this scheme in the DCP-Auto mode before the device enters BC1.2 shorted mode. To simulate this charging scheme D+/D– lines are shorted and pulled-up to 1.2 V for fixed duration then device moves to DCP shorted mode as defined in BC1.2 specification. This is shown in Figure 31.



**Figure 31. DCP 1.2-V Charging Scheme**

### 8.3.4 Wake on USB Feature (Mouse/Keyboard Wake Feature)

#### 8.3.4.1 USB 2.0 Background Information

The TPS2547 data lines interface with USB 2.0 devices. USB 2.0 defines three types of devices according to data rate. These devices and their characteristics relevant to TPS2547 Wake on USB operation are shown below.

Low-speed USB devices:

- 1.5 Mbps
- Wired mice and keyboards are examples
- No devices that need battery charging
- All signaling performed at 2 V and 0.8 V hi/lo logic levels
- D– high to signal connect and when placed into suspend
- D– high when not transmitting data packets

Full-speed USB devices:

- 12 Mbps
- Wireless mice and keyboards are examples
- Legacy phones and music players are examples
- Some legacy devices that need battery charging
- All signaling performed at 2 V and 0.8 V hi/lo logic levels
- D+ high to signal connect and when placed into suspend
- D+ high when not transmitting data packets

High-speed USB devices:

- 480 Mbps
- Tablets, phones and music players are examples
- Many devices that need battery charging
- Connect and suspend signaling performed at 2 V and 0.8 V hi/lo logic levels
- Data packet signaling performed a logic levels below 0.8 V
- D+ high to signal connect and when placed into suspend (same as a full-speed device)

## Feature Description (continued)

- D+ and D– low when not transmitting data packets

### 8.3.4.2 Wake On USB

Wake on USB is the ability of a wake configured USB device to wake a computer system from its S3 sleep state back to its S0 working state. Wake on USB requires the data lines to be connected to the system USB host before the system is placed into its S3 sleep state, and remain continuously connected until they are used to wake the system.

The TPS2547 supports low-speed and high-speed HID (human interface device like mouse/key board) wake function. There are two scenarios under which wake on mouse are supported by the TPS2547. The specific CTL pin changes that the TPS2547 overrides are shown below. The information is presented as CTL1, CTL2, CTL3. The ILIM\_SEL pin plays no role.

1. 111 (CDP/SDP2) to 011 (DCP-Auto)
2. 010 (SDP1) to 011 (DCP-Auto)

---

#### NOTE

The 110 (SDP1) to 011 (DCP-Auto) transition is not supported. This is done for practical reasons, because the transition involves changes to two CTL pins. Depending on which CTL pin changes first, the device sees either a temporary 111 or 010 command. The 010 command is safe but the 111 command causes an OUT discharge as the TPS2547 instead proceeds to the 111 state.

---

### 8.3.4.3 USB Slow-Speed and Full-Speed Device Recognition

TPS2547 is capable of detecting LS or FS device attachment when TPS2547 is in SDP or CDP mode. Per USB specification, when no device is attached, the D+ and D– lines are near ground level. When a low-speed compliant device is attached to the TPS2547 charging port, D– line is pulled high in its idle state (mouse/keyboard not activated). However, when a FS device is attached then the opposite is true in its idle state, that is, D+ is pulled high and D– remains at ground level.

TPS2547 monitors both D+ and D– lines while CTL pin settings are in CDP or SDP mode to detect LS or FS HID device attachment. To support HID sleep wake, TPS2547 must first determine that it is attached to a LS or FS device when system is in S0 power state. TPS2547 does this as described above. While supporting a LS HID wake is straight forward, supporting FS HID requires making a distinction between a FS and a HS device. This is because a high-speed device always presents itself initially as a full speed device (by a 1.5-K pullup resistor on D+). The negotiation for high speed then makes the distinction whereby the 1.5-K pullup resistor gets removed.

TPS2547 handles the distinction between a FS and HS device at connect by memorizing if the D+ line goes low after connect. A HS device after connect always undergoes negotiation for HS, which requires the 1.5-k $\Omega$  resistor pullup on D+ to be removed. To memorize a FS device, TPS2547 requires the device to remain connected for at least 60 seconds while the system is in S0 mode, before placing it in sleep or S3 mode.

---

#### NOTE

If system is placed in sleep mode earlier than the 60 second window, a FS device may not get recognized and hence could fail to wake system from S3. This requirement does not apply for LS device.

---

#### 8.3.4.3.1 No CTL Pin Timing Requirement After Wake Event and Transition from S3 to S0

Unlike the TPS2543, there is no CTL pin timing requirement for the TPS2547 when the wake configured USB device wakes the system from S3 back to S0. The TPS2543 requires the CTL pins to transition from the DCP-Auto setting back to the SDP/CDP setting within 64 ms of the attached USB device signaling a wake event (for example, mouse clicked or keyboard key pressed). No such timing condition exists for the TPS2547.

## Feature Description (continued)

### 8.3.5 Load Detect

TPS2547 offers system designers unique power management strategy not available in the industry from similar devices. There are two power management schemes supported by the TPS2547 through the  $\overline{\text{STATUS}}$  pin, they are:

- Power Wake (PW)
- Port Power Management (PPM)

Either feature may be implemented in a system depending on power savings goals for the system. In general, Power Wake feature is used mainly in mobile systems, like a notebook, where it is imperative to save battery power when system is in deep sleep (S4/S5) state. Oppositely, Port Power Management feature would be implemented where multiple charging ports are supported in the same system, and system power rating is not capable of supporting high-current charging on multiple ports simultaneously.

### 8.3.6 Power Wake

The goal of the power wake feature is to save system power when the system is in S4/S5 state. In the S4/S5 state, the system is in deep sleep and typically running off the battery; so every mW in system power savings translates to extending battery life. In this state, the TPS2547 monitors charging current at the OUT pin and provide a mechanism through the  $\overline{\text{STATUS}}$  pin to switch out the high-power DC-DC controller and switch in a low power LDO when charging current requirement is  $< 45$  mA (typical). This would be the case when no peripheral device is connected at the charging port or if a device has attained its full battery charge and draws  $< 45$  mA. A power wake flow chart and description is shown in [Figure 32](#).

Feature Description (continued)

- Load being Charged
- TPS2547 is asserting power wake
  - System power is at its full capability
  - Load can charge at high current
  - TPS2547 monitors port to detect when charging load is done charging or removed

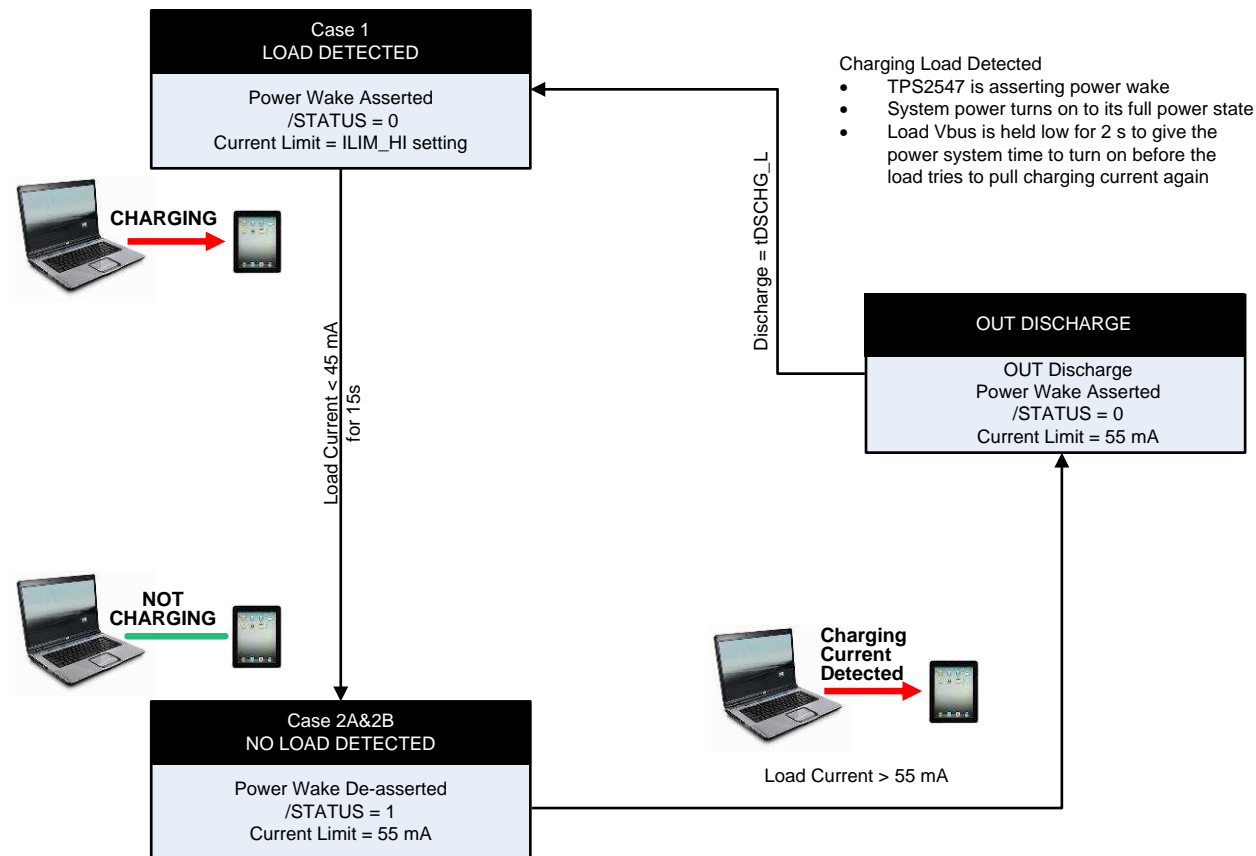

- Charging Load Detected
- TPS2547 is asserting power wake
  - System power turns on to its full power state
  - Load Vbus is held low for 2 s to give the power system time to turn on before the load tries to pull charging current again

- Charging Load Not Detected.
- TPS2547 is not asserting power wake. System power is in a low power state to save energy.
  - TPS2547 monitors port to detect when charging load is attached and tries to charge

Copyright © 2017, Texas Instruments Incorporated

Figure 32. Power Wake Flow Chart

## Feature Description (continued)

### 8.3.6.1 Implementing Power Wake in Notebook System

An implementation of power wake in notebook platforms with the TPS2547 is shown in Figure 33 to Figure 35. Power wake function is used to select between a high-power DC-DC converter, and low-power LDO (100 mA) based on charging requirements. System power saving is achieved when under no charging conditions (the connected device is fully charged or no device is connected) the DC-DC converter is turned off (to save power because it is less efficient in low-power operating region) and the low-power LDO supplies standby power to the charging port.

Power wake is activated in S4/S5 mode (0011 setting, see Table 3), TPS2547 is charging connected device as shown in Figure 33, STATUS is pulled LO (Case 1) which switches-out the LDO and switches-in the DC-DC converter to handle high-current charging.

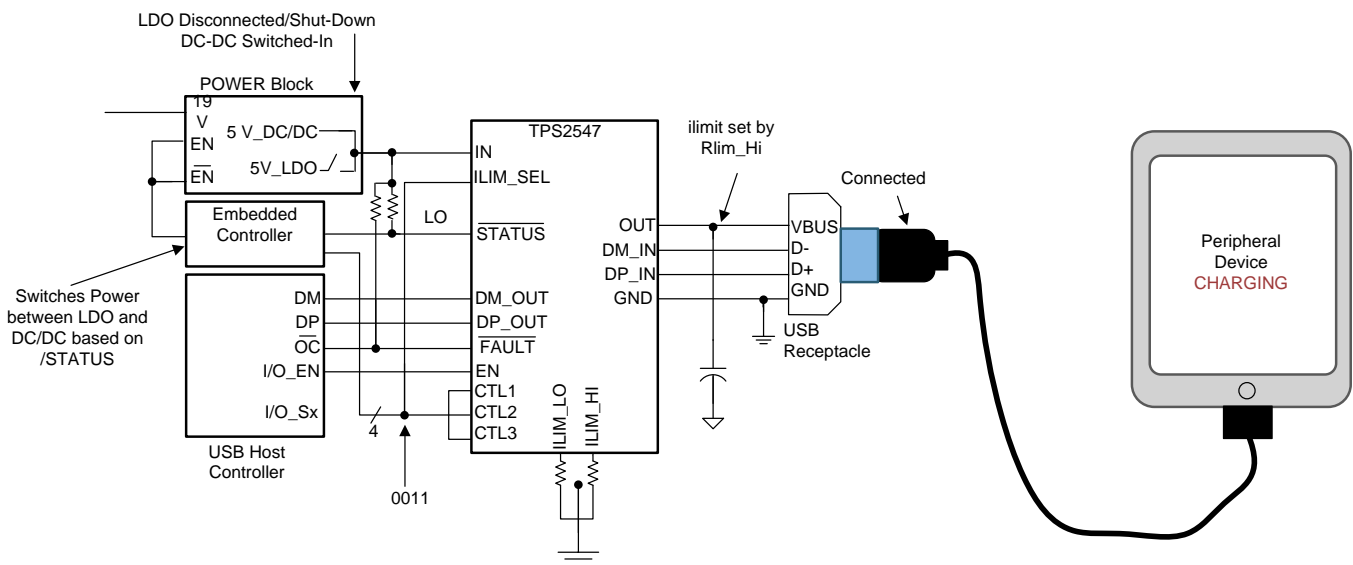

Copyright © 2017, Texas Instruments Incorporated

Figure 33. Case 1: System in S4/S5, Device Charging

As shown in Figure 34 and Figure 35, when connected device is fully charged or gets disconnected from the charging port, the charging current falls. If charging current falls to  $< 45$  mA and stays below this threshold for over 15 s, TPS2547 automatically sets a 55-mA internal current limit and STATUS is de-asserted (pulled HI). As shown in Figure 34 and Figure 35. This results in DC-DC converter turning off, and the LDO turning on. Current limit of 55 mA is set to prevent the low-power LDO output voltage from collapsing in case there is a spike in current draw due to device attachment or other activity such as display panel LED turning ON in connected device.

Following Power Wake flow chart (Figure 32) when a device is attached and draws  $\geq 55$  mA of charging current the TPS2547 hits its internal current limit. This triggers the device to assert STATUS (LO), and turn on the DC-DC converter and turn off the LDO. TPS2547 discharges OUT for  $> 2$  s (typical), allowing the main power supply to turn on. After the discharge, the device turns back on with current limit set by ILIM\_HI (Case 1).

Feature Description (continued)

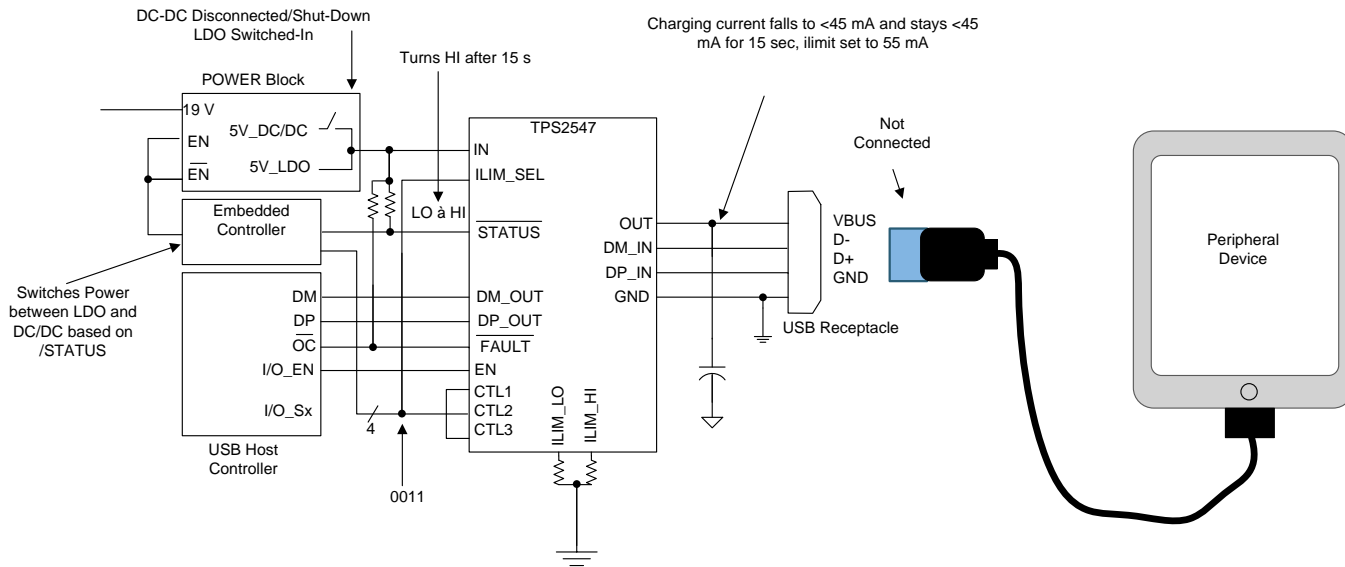

Copyright © 2017, Texas Instruments Incorporated

Figure 34. Case 2A: System in S4/S5, No Device Attached

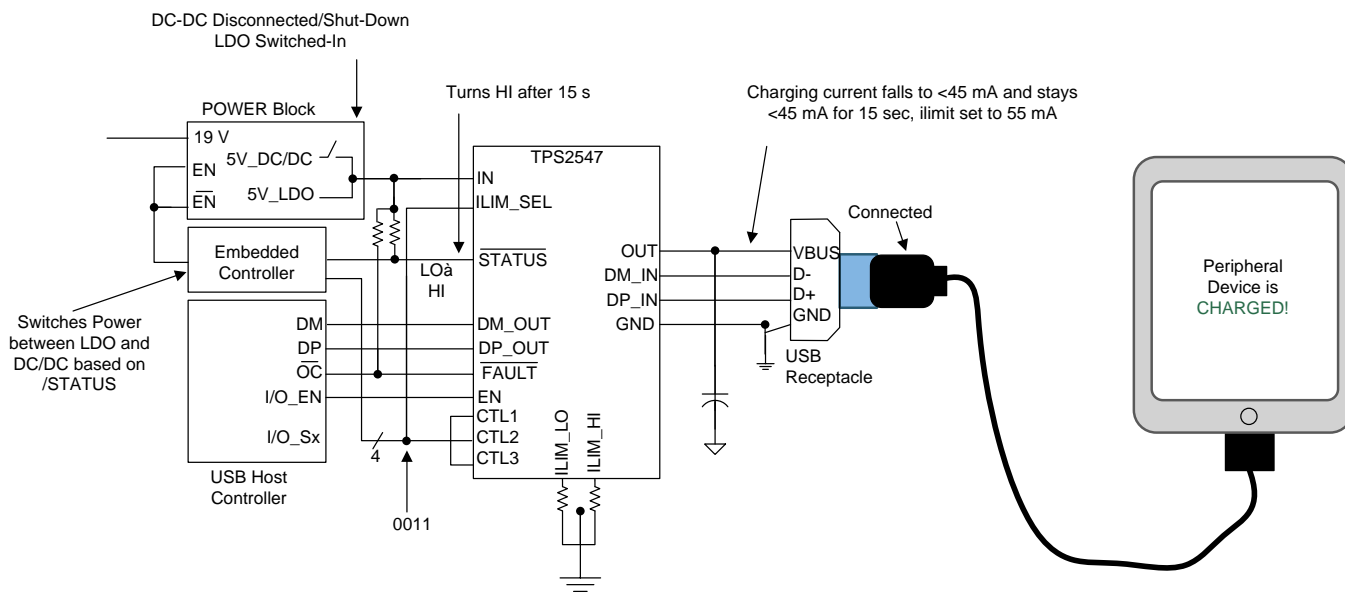

Copyright © 2017, Texas Instruments Incorporated

Figure 35. Case 2B: System in S4/S5, Attached Device Fully Charged

## Feature Description (continued)

### 8.3.7 Port Power Management (PPM)

PPM is the intelligent and dynamic allocation of power for systems that have multiple charging ports but cannot power them all simultaneously. The goals of this feature are:

- Enhance user experience because user does not have to search for charging port
- Ensure the power supply only has to be designed for a reasonable charging load

Initially all ports are allowed to broadcast high-current charging, charging current limit is based on ILIM\_HI resistor setting. System monitors STATUS to see when high-current loads are present. Once allowed number of ports assert STATUS, remaining ports are toggled to a non-charging port. Non-charging ports are SDP ports with current limit based on ILIM\_LO. TPS2547 allows for a system to toggle between charging and non-charging ports either with an OUT discharge or without an OUT discharge.

#### 8.3.7.1 Benefits of PPM

- Delivers better user experience
- Prevents overloading of system's power supply
- Allows for dynamic power limits based on system state
- Allows every port to potentially be a high-power charging port
- Allows for smaller power supply capacity because the loading is controlled

#### 8.3.7.2 PPM Details

All ports are allowed to broadcast high-current charging – CDP or DCP. Current limit is based on ILIM\_HI and system monitors STATUS pin to see when high-current loads are present. Once allowed number of ports assert STATUS, remaining ports are toggled to a SDP non-charging port. SDP current limit is based on ILIM\_LO setting. SDP ports are automatically toggled back to CDP or DCP mode when a charging port de-asserts STATUS.

Based on CTL settings there is a provision for a port to toggle between charging and non-charging ports either with a Vbus discharge or without a Vbus discharge. For example when a port is in SDP2 mode (1110) and its ILIM\_SEL pin is toggled to 1 due to another port releasing its high-current requirements. The SDP2 port automatically reverts to CDP mode (1111) without a discharge event. This is desirable if this port was connected to a media device where it was syncing data from the SDP2 port; a discharge event would disrupt the syncing activity on the port and cause user confusion.

STATUS trip point is based on the programmable ILIM\_LO current limit set point. This does not mean STATUS is a current limit – the port itself is using the ILIM\_HI current limit. Since ILIM\_LO defines the current limit for a SDP port, it works well to use the ILIM\_LO value to define a high-current load. STATUS asserts in CDP and DCP when load current is above  $ILIM\_LO + 60\text{ mA}$  for 200 ms. STATUS also asserts in CDP when an attached device does a BC1.2 primary detection. STATUS de-asserts in CDP and DCP when the load current is below  $ILIM\_LO + 10\text{ mA}$  for 3 s.

#### 8.3.7.3 Implementing PPM in a System with Two Charging Ports

Figure 36 shows implementation of two charging ports, each with its own TPS2547. In this example 5-V power supply for the two charging ports is rated at  $< 3\text{ A}$  or  $< 15\text{ W}$  maximum. Both devices have  $R_{LIM}$  chosen to correspond to the low (0.9 A) and high (1.5 A) current limit setting for the port. In this implementation the system can support only one of the two ports at 1.5-A charging current while the other port is set to SDP mode and  $I_{LIMIT}$  corresponding to 0.9 A.

## Feature Description (continued)

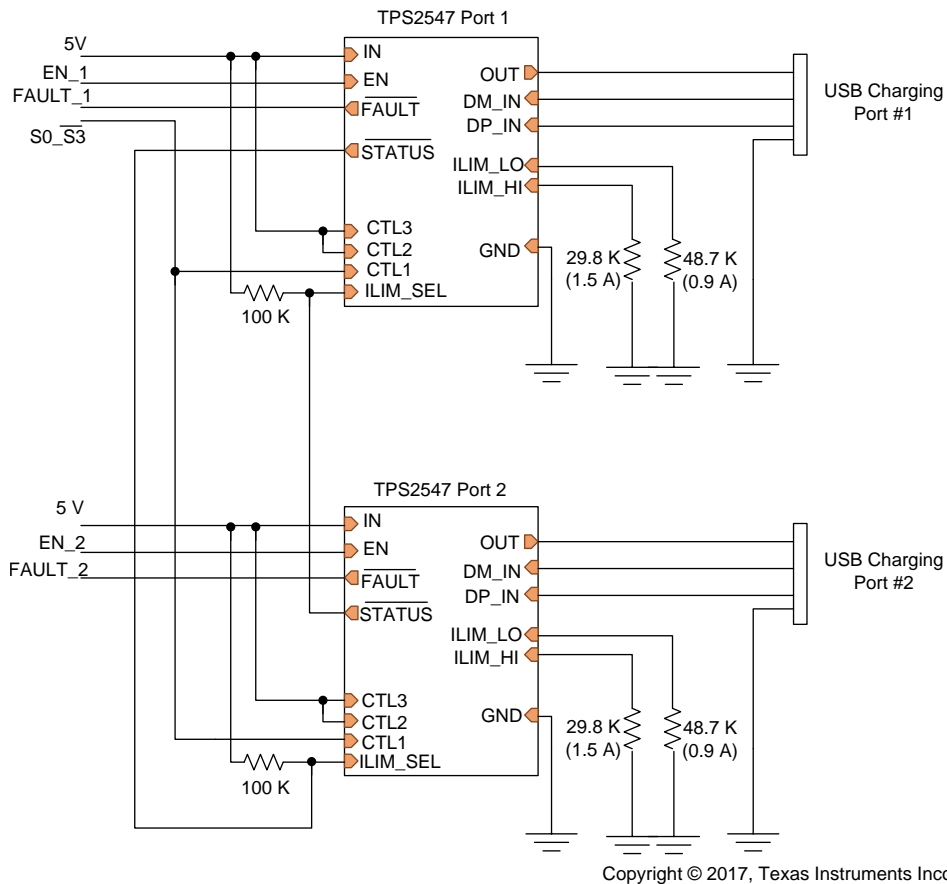

Figure 36. Implementing Port Power Management in a System Supporting Two Charging Ports

### 8.3.8 Overcurrent Protection

When an overcurrent condition is detected, the device maintains a constant output current and reduces the output voltage accordingly. Two possible overload conditions can occur. In the first condition, the output has been shorted before the device is enabled or before VIN has been applied. The TPS2547 senses the short and immediately switches into a constant-current output. In the second condition, a short or an overload occurs while the device is enabled. At the instant the overload occurs, high currents may flow for nominally one to two microseconds before the current-limit circuit can react. The device operates in constant-current mode after the current-limit circuit has responded. Complete shutdown occurs only if the fault is present long enough to activate thermal limiting. The device remains off until the junction temperature cools approximately 20°C and then restarts. The device continues to cycle on/off until the overcurrent condition is removed.

### 8.3.9 FAULT Response

The  $\overline{\text{FAULT}}$  open-drain output is asserted (active low) during an overtemperature or current limit condition. The output remains asserted until the fault condition is removed. The TPS2547 is designed to eliminate false  $\overline{\text{FAULT}}$  reporting by using an internal de-glitch circuit for current limit conditions without the need for external circuitry. This ensures that  $\overline{\text{FAULT}}$  is not accidentally asserted due to normal operation such as starting into a heavy capacitive load. Overtemperature conditions are not de-glitched and assert the  $\overline{\text{FAULT}}$  signal immediately.

### 8.3.10 Undervoltage Lockout (UVLO)

The undervoltage lockout (UVLO) circuit disables the power switch until the input voltage reaches the UVLO turnon threshold. Built-in hysteresis prevents unwanted oscillations on the output due to input voltage drop from large current surges.

## Feature Description (continued)

### 8.3.11 Thermal Sense

The TPS2547 protects itself with two independent thermal sensing circuits that monitor the operating temperature of the power distribution switch and disables operation if the temperature exceeds recommended operating conditions. The device operates in constant-current mode during an overcurrent condition, which increases the voltage drop across power switch. The power dissipation in the package is proportional to the voltage drop across the power switch, so the junction temperature rises during an overcurrent condition. The first thermal sensor turns off the power switch when the die temperature exceeds 135°C and the part is in current limit. The second thermal sensor turns off the power switch when the die temperature exceeds 155°C regardless of whether the power switch is in current limit. Hysteresis is built into both thermal sensors, and the switch turns on after the device has cooled by approximately 20°C. The switch continues to cycle off and on until the fault is removed. The open-drain false reporting output FAULT is asserted (active low) during an overtemperature shutdown condition.

## 8.4 Device Functional Modes

Table 1 shows the differences between these ports.

Table 1. Operating Modes

PORT TYPE	SUPPORT USB 2.0 COMMUNICATION	MAXIMUM ALLOWABLE CURRENT DRAW BY PORTABLE DEVICE (A)
SDP (USB 2.0)	Yes	0.5
SDP (USB 3.0)	Yes	0.9
CDP	Yes	1.5
DCP	No	1.5

### 8.4.1 DCP Auto Mode

As mentioned above the TPS2547 integrates an auto-detect state machine that supports all the above DCP charging schemes. It starts in Divider1 scheme, however if a BC1.2 or YD/T 1591-2009 compliant device is attached, the TPS2547 responds by discharging OUT, turning back on the power switch and operating in 1.2 V mode briefly and then moving to BC1.2 DCP mode. It then stays in that mode until the device releases the data line, in which case it goes back to Divider1 scheme. When a Divider1 compliant device is attached the TPS2547 stays in Divider1 state.

Also, the TPS2547 automatically switches between the Divider1 and Divider2 schemes based on charging current drawn by the connected device. Initially the device sets the data lines to Divider1 scheme. If charging current of > 750 mA is measured by the TPS2547 it switches to Divider2 scheme and test to see if the peripheral device still charges at a high current. If it does then it stays in Divider2 scheme otherwise it reverts to Divider1 scheme.

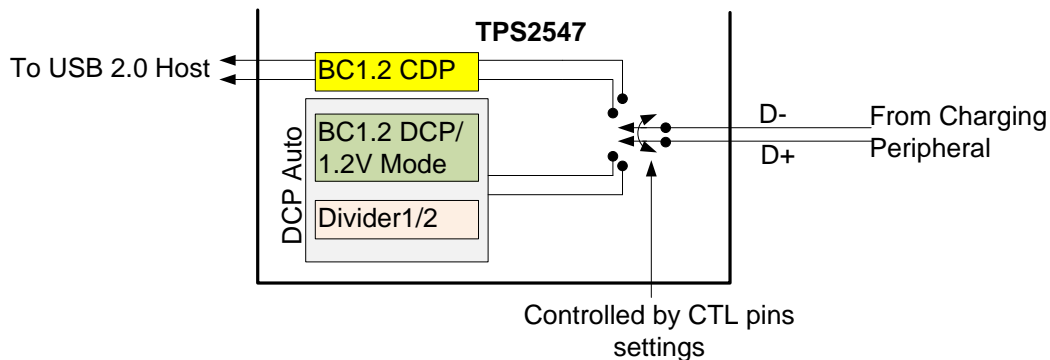

Copyright © 2017, Texas Instruments Incorporated

Figure 37. DCP Auto Mode

### 8.4.2 DCP Forced Shorted / DCP Forced Divider1

In this mode the device is permanently set to one of the DCP schemes (BC1.2/ YD/T 1591-2009 or Divider1) as commanded by its control pin setting per [Table 3](#).

### 8.4.3 High-Bandwidth Data Line Switch

The TPS2547 passes the D+ and D– data lines through the device to enable monitoring and handshaking while supporting charging operation. A wide bandwidth signal switch is used, allowing data to pass through the device without corrupting signal integrity. The data line switches are turned on in any of CDP or SDP operating modes. The EN input also needs to be at logic High for the data line switches to be enabled.

#### NOTE

- While in CDP mode, the data switches are ON even while CDP handshaking is occurring
- The data line switches are OFF if EN or all CTL pins are held low, or if in DCP mode. They are not automatically turned off if the power switch (IN to OUT) is in current limit
- The data switches are for USB 2.0 differential pair only. In the case of a USB 3.0 host, the super speed differential pairs must be routed directly to the USB connector without passing through the TPS2547
- Data switches are OFF during OUT (VBUS) discharge

[Table 2](#) can be used as an aid to program the TPS2547 per system states however not restricted to below settings only.

**Table 2. Control Pin Settings Matched to System Power States**

SYSTEM GLOBAL POWER STATE	TPS2547 CHARGING MODE	CTL1	CTL2	CTL3	ILIM_SEL	CURRENT LIMIT SETTING
S0	SDP1	1	1	0	1 or 0	ILIM_HI / ILIM_LO
S0	SDP2, no discharge to / from CDP	1	1	1	0	ILIM_LO
S0	CDP, load detection with ILIM_LO + 60-mA thresholds or if a BC1.2 primary detection occurs	1	1	1	1	ILIM_HI
S4/S5	Auto mode, load detection with power wake thresholds	0	0	1	1	ILIM_HI
S3/S4/S5	Auto mode, no load detection	0	0	1	0	ILIM_HI
S3	Auto mode, keyboard/mouse wake up, load detection with ILIM_LO + 60 mA thresholds	0	1	1	1	ILIM_HI
S3	Auto mode, keyboard/mouse wake-up, no load detection	0	1	1	0	ILIM_HI
S3	SDP1, keyboard/mouse wake-up	0	1	0	1 or 0	ILIM_HI / ILIM_LO

### 8.4.4 Device Truth Table (TT)

Device TT lists all valid bias combinations for the three control pins CTL1-3 and ILIM\_SEL pin and their corresponding charging mode. It is important to note that the TT purposely omits matching charging modes of the TPS2547 with global power states (S0-S5) as device is agnostic to system power states. The TPS2547 monitors CTL inputs and transitions to the charging state it is commanded to go to (except when LS/FS HID device is detected). For example, if sleep charging is desired when system is in standby or hibernate state then the user must set TPS2547 CTL pins to correspond to DCP\_Auto charging mode as shown in the below table. When the system resumes operation mode set the control pins to correspond to SDP or CDP mode, as seen in [Table 3](#).

**Table 3. Truth Table**

CTL1	CTL2	CTL3	ILIM_SEL	MODE	CURRENT LIMIT SETTING	STATUS OUTPUT (ACTIVE LOW)	COMMENT
0	0	0	0	Discharge	NA	OFF	OUT held low.
0	0	0	1	Discharge	NA	OFF	
0	0	1	0	DCP_Auto	ILIM_HI	OFF	Data lines disconnected.
0	0	1	1	DCP_Auto	$I_{OS\_PW}$ & ILIM_HI <sup>(1)</sup>	DCP load present <sup>(2)</sup>	Data lines disconnected and load detect function active.
0	1	0	0	SDP1	ILIM_LO	OFF	Data lines connected.
0	1	0	1	SDP1	ILIM_HI	OFF	
0	1	1	0	DCP_Auto	ILIM_HI	OFF	Data lines disconnected.
0	1	1	1	DCP_Auto	ILIM_HI	DCP load present <sup>(3)</sup>	Data lines disconnected and load detect function active.
1	0	0	0	DCP_Shorted	ILIM_LO	OFF	Device forced to stay in DCP BC1.2 charging mode.
1	0	0	1	DCP_Shorted	ILIM_HI	OFF	
1	0	1	0	DCP / Divider1	ILIM_LO	OFF	Device forced to stay in DCP divider1 charging mode.
1	0	1	1	DCP / Divider1	ILIM_HI	OFF	
1	1	0	0	SDP1	ILIM_LO	OFF	Data lines connected.
1	1	0	1	SDP1	ILIM_HI	OFF	
1	1	1	0	SDP2 <sup>(4)</sup>	ILIM_LO	OFF	
1	1	1	1	CDP <sup>(4)</sup>	ILIM_HI	CDP load present <sup>(5)</sup>	

(1) TPS2547 : Current limit ( $I_{OS}$ ) is automatically switched between  $I_{OS\_PW}$  and the value set by ILIM\_HI according to the Load Detect – Power Wake functionality.

(2) DCP Load present governed by the Load Detection – Power Wake limits.

(3) DCP Load present governed by the Load Detection – Non Power Wake limits.

(4) No OUT discharge when changing between 1111 and 1110.

(5) CDP Load present governed by the Load Detection – Non Power Wake limits and BC1.2 primary detection.

## 9 Application and Implementation

### NOTE

Information in the following applications sections is not part of the TI component specification, and TI does not warrant its accuracy or completeness. TI's customers are responsible for determining suitability of components for their purposes. Customers must validate and test their design implementation to confirm system functionality.

### 9.1 Application Information

Power-on-reset (POR) holds device in initial state while output is held in discharge mode. Any POR event returns the device to initial state. After POR clears, device goes to the next state depending on the CTL lines as shown in Figure 38.

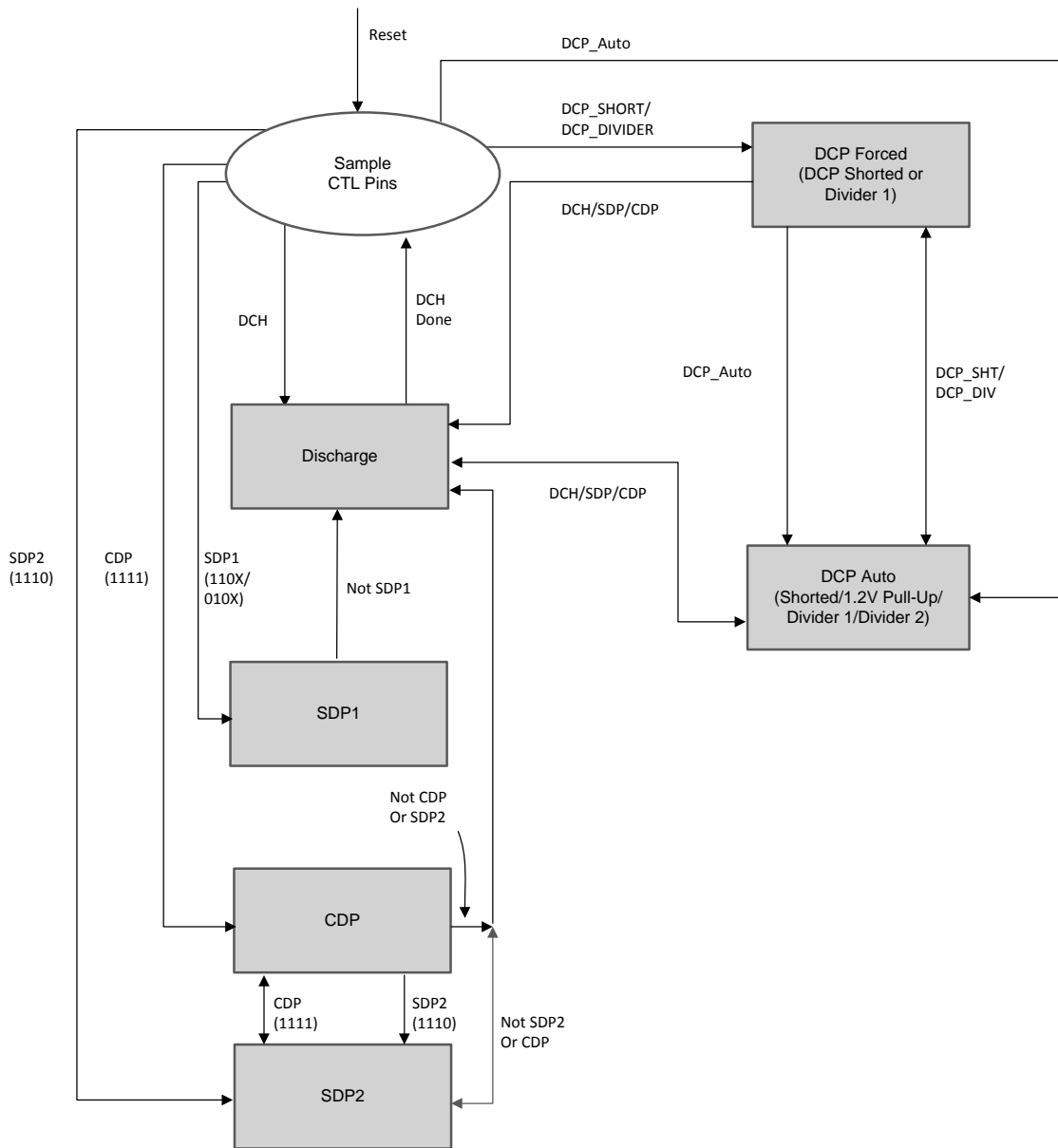

Copyright © 2016, Texas Instruments Incorporated

Figure 38. TPS2547 Charging States

## Application Information (continued)

### 9.1.1 Output Discharge

To allow a charging port to renegotiate current with a portable device, the TPS2547 device uses the OUT discharge function. The device proceeds by turning off the power switch while discharging OUT. The device then turns on the power switch again to reassert the OUT voltage. This discharge function is automatically applied, as shown in Figure 26. There are two discharge times,  $t_{DCHG\_L}$  and  $t_{DCHG\_S}$ .  $t_{DCHG\_L}$  is from SDP1/SDP2/CDP to DCP\_Auto, and  $t_{DCHG\_S}$  is from DCP\_Auto to SDP1/SDP2/CDP.

## 9.2 Typical Application

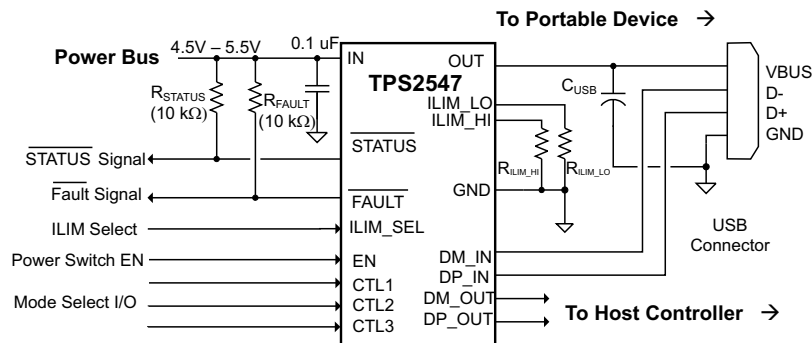

Copyright © 2017, Texas Instruments Incorporated

**Figure 39. Typical Application Schematic USB Port Charging**

### 9.2.1 Design Requirements

For this design example, use the parameters listed in Table 4.

**Table 4. Design Parameters**

DESIGN PARAMETER	EXAMPLE VALUE
Input voltage, $V_{(IN)}$	5 V
Output voltage, $V_{(DC)}$	5 V
Maximum continuous output current, $I_{(OUT)}$	2.5 A
Current limit, $I_{(LIM\_LO)}$ at $R_{ILIM\_LO} = 80.6 \text{ k}\Omega$	0.625 A
Current Limit, $I_{(LIM\_HI)}$ at $R_{ILIM\_HI} = 16.9 \text{ k}\Omega$	2.97 A

### 9.2.2 Detailed Design Procedure

#### 9.2.2.1 Current-Limit Settings

The TPS2547 has two independent current limit settings that are each programmed externally with a resistor. The ILIM\_HI setting is programmed with  $R_{ILIM\_HI}$  connected between ILIM\_HI and GND. The ILIM\_LO setting is programmed with  $R_{ILIM\_LO}$  connected between ILIM\_LO and GND. Consult the Device Truth Table (Table 3) to see when each current limit is used. Both settings have the same relation between the current limit and the programming resistor.

$R_{ILIM\_LO}$  is optional and the ILIM\_LO pin may be left unconnected if the following conditions are met:

1. ILIM\_SEL is always set high
2. Load Detection - Port Power Management is not used

Equation 1 programs the typical current limit:

$$R_{LIM\_XX}(\text{k}\Omega) = \frac{51829}{I_{OS\_typ}(\text{mA})} \quad (1)$$

$R_{ILIM\_XX}$  corresponds to either  $R_{ILIM\_HI}$  or  $R_{ILIM\_LO}$  as appropriate.

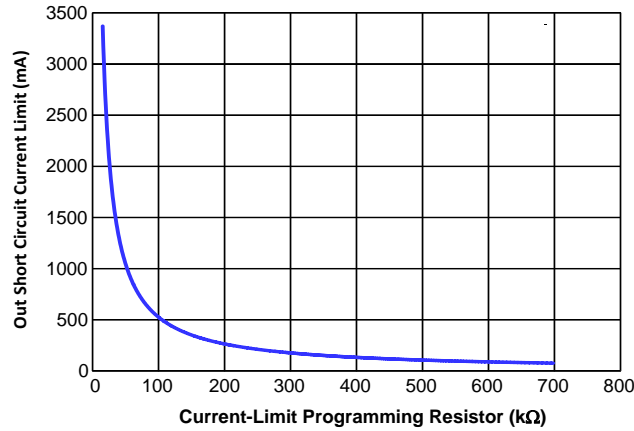

Full  $R_{LIM\_XX}$  Range

Figure 40. Typical Current Limit Setting vs Programming Resistor

Many applications require that the current limit meet specific tolerance limits. When designing to these tolerance limits, both the tolerance of the TPS2547 current limit and the tolerance of the external programming resistor must be taken into account. The following equations approximate the TPS2547 minimum and maximum current limits to within a few mA, and are appropriate for design purposes. The equations do not constitute part of Texas Instrument's published device specifications for purposes of Texas Instrument's product warranty. These equations assume an ideal - no variation - external programming resistor. To take resistor tolerance into account, first determine the minimum and maximum resistor values based on its tolerance specifications, and use these values in the equations. Because of the inverse relation between the current limit and the programming resistor, use the maximum resistor value in the Equation 2 and the minimum resistor value in the Equation 3.

$$I_{OS\_min} (mA) = \frac{52069}{R_{LIM\_XX}^{(1.023)} (k\Omega)} \tag{2}$$

$$I_{OS\_max} (mA) = \frac{52090}{R_{LIM\_XX}^{(0.978)} (k\Omega)} \tag{3}$$

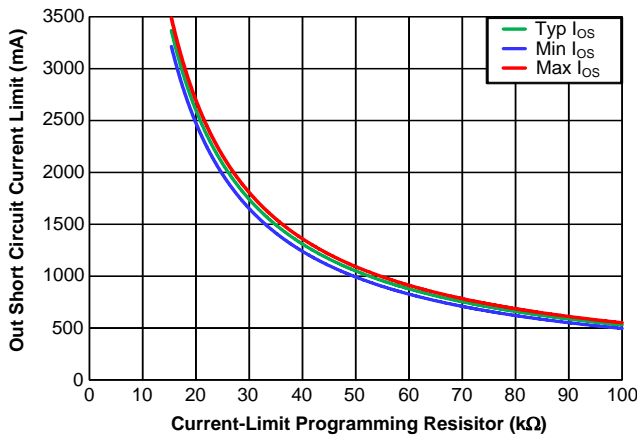

Figure 41. Current Limit Setting vs Programming Resistor

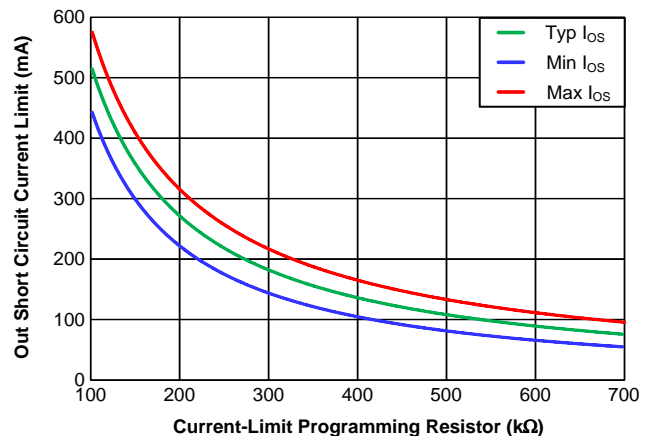
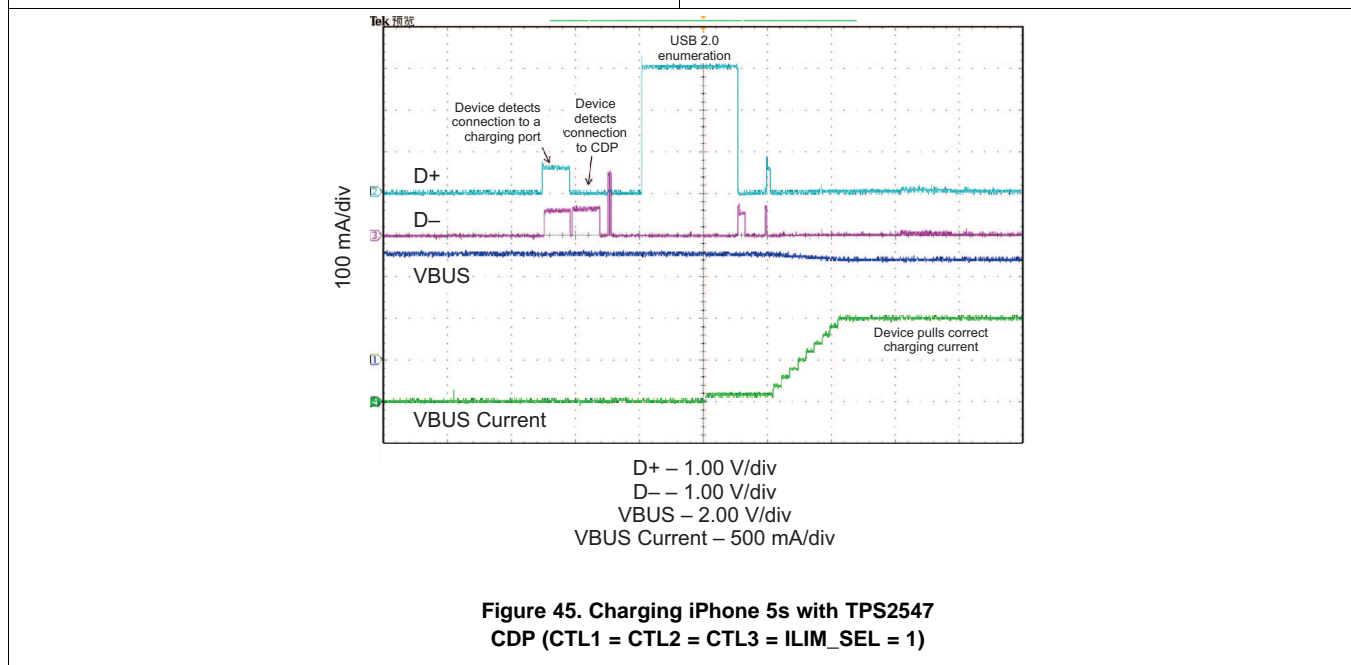
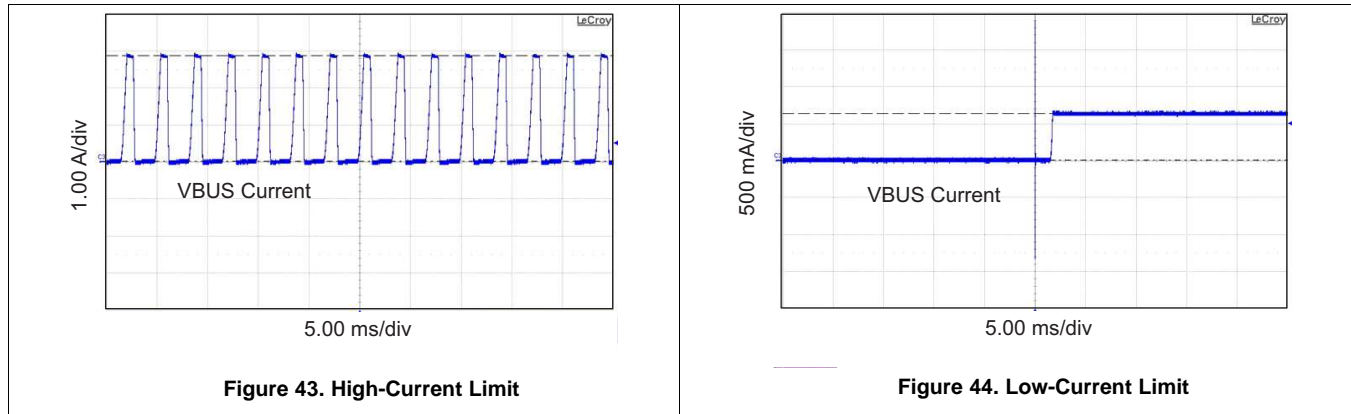

Figure 42. Current Limit Setting vs Programming Resistor

The traces routing the  $R_{LIM\_XX}$  resistors must be a sufficiently low resistance as to not affect the current-limit accuracy. The ground connection for the  $R_{LIM\_XX}$  resistors is also very important. The resistors need to reference back to the TPS2547 GND pin. Follow normal board layout practices to ensure that current flow from other parts of the board does not impact the ground potential between the resistors and the TPS2547 GND pin.

### 9.2.3 Application Curves



## 10 Power Supply Recommendations

The TPS2547 device is designed for a supply-voltage range of  $4.5\text{ V} \leq V_{IN} \leq 5.5\text{ V}$ . If the input supply is located more than a few inches from the device, an input ceramic bypass capacitor higher than  $0.1\text{ }\mu\text{F}$  is recommended. In order to avoid drops in voltage during overcurrent and short-circuit conditions, choose a power supply rated higher than the TPS2547 current-limit setting.

## 11 Layout

### 11.1 Layout Guidelines

For the trace routing of DP\_IN, DM\_IN, DP\_OUT, and DM\_OUT: route these traces as micro-strips with nominal differential impedance of  $90\text{ }\Omega$ . Minimize the use of vias in the high-speed data lines. Keep the reference GND plane devoid from cuts or splits above the differential pairs to prevent impedance discontinuities. For more information, see the *High-Speed USB Platform Design Guidelines* from Intel.

The trace routing from the upstream regulator to the TPS2547 IN pin must be as short as possible to reduce voltage drop and parasitic inductance.



## Layout Guidelines (continued)

In order to meet IEC61000-4-2 level 4 ESD, external circuitry is required. Refer to the guidelines provided in the [相关文档](#) section.

The traces routing from the RILIM\_HI and RILIM\_LO resistors to the device must be as short as possible to reduce parasitic effects on the current-limit accuracy.

The thermal pad must be directly connected to the PCB ground plane using wide and short copper trace.

### 11.2 Layout Example

-  Top Layer Signal Trace
-  Top Layer Signal Ground Plane
-  Bottom Layer Signal Trace
-  Via to Bottom layer Signal Ground Plane
-  Via to Bottom layer Signal

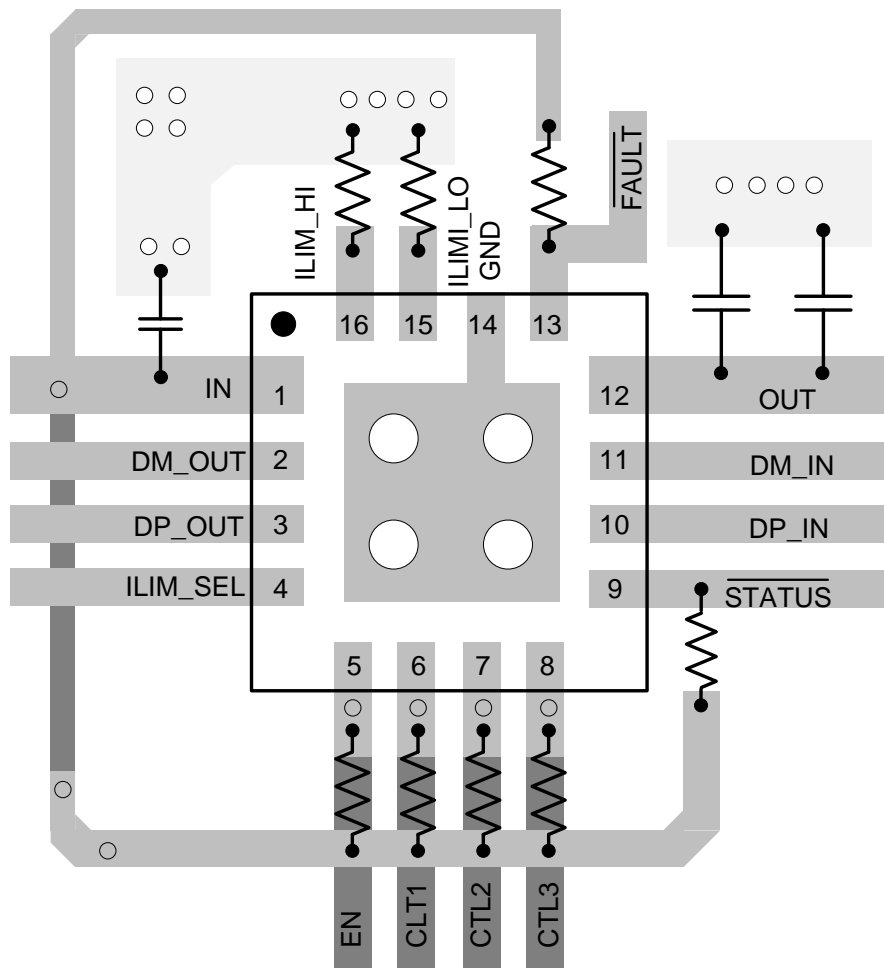

Figure 46. Layout Recommendation

## 12 器件和文档支持

### 12.1 文档支持

#### 12.1.1 相关文档

相关文档如下：

《适用于 TPS254x USB 充电端口控制器的高效系统 ESD 保护》，SLVA796。

《Intel 高速 USB 平台设计指南》([www.usb.org/developers/docs/hs\\_usb\\_pdg\\_r1\\_0.pdf](http://www.usb.org/developers/docs/hs_usb_pdg_r1_0.pdf))

《USB 2.0 规范》([www.usb.org/developers/docs/usb20\\_docs/#usb20spec](http://www.usb.org/developers/docs/usb20_docs/#usb20spec))

《BC1.2 电池充电规范》([kinetis.pl/sites/default/files/BC1.2\\_FINAL.pdf](http://kinetis.pl/sites/default/files/BC1.2_FINAL.pdf))

### 12.2 接收文档更新通知

要接收文档更新通知，请导航至德州仪器 TI.com.cn 上的器件产品文件夹。请单击右上角的通知我进行注册，即可收到任意产品信息更改每周摘要。有关更改的详细信息，请查看任意已修订文档中包含的修订历史记录。

### 12.3 社区资源

下列链接提供到 TI 社区资源的连接。链接的内容由各个分销商“按照原样”提供。这些内容并不构成 TI 技术规范，并且不一定反映 TI 的观点；请参阅 TI 的《使用条款》。

**TI E2E™ 在线社区** TI 的工程师对工程师 (E2E) 社区。此社区的创建目的在于促进工程师之间的协作。在 e2e.ti.com 中，您可以咨询问题、分享知识、拓展思路并与同行工程师一道帮助解决问题。

**设计支持** TI 参考设计支持 可帮助您快速查找有帮助的 E2E 论坛、设计支持工具以及技术支持的联系信息。

### 12.4 商标

E2E is a trademark of Texas Instruments.  
All other trademarks are the property of their respective owners.

### 12.5 静电放电警告



这些装置包含有限的内置 ESD 保护。存储或装卸时，应将导线一起截短或将装置放置于导电泡棉中，以防止 MOS 门极遭受静电损伤。

### 12.6 Glossary

**SLYZ022** — TI Glossary.

This glossary lists and explains terms, acronyms, and definitions.

## 13 机械、封装和可订购信息

以下页面包括机械、封装和可订购信息。这些信息是指定器件的最新可用数据。这些数据发生变化时，我们可能不会另行通知或修订此文档。如欲获取此产品说明书的浏览器版本，请参阅左侧的导航栏。

**PACKAGING INFORMATION**

Orderable Device	Status (1)	Package Type	Package Drawing	Pins	Package Qty	Eco Plan (2)	Lead finish/ Ball material (6)	MSL Peak Temp (3)	Op Temp (°C)	Device Marking (4/5)	Samples
TPS2547RTER	ACTIVE	WQFN	RTE	16	3000	RoHS & Green	NIPDAU	Level-1-260C-UNLIM	-40 to 115	2547	<a href="#">Samples</a>
TPS2547RTET	ACTIVE	WQFN	RTE	16	250	RoHS & Green	NIPDAU	Level-1-260C-UNLIM	-40 to 115	2547	<a href="#">Samples</a>

(1) The marketing status values are defined as follows:

**ACTIVE:** Product device recommended for new designs.

**LIFEBUY:** TI has announced that the device will be discontinued, and a lifetime-buy period is in effect.

**NRND:** Not recommended for new designs. Device is in production to support existing customers, but TI does not recommend using this part in a new design.

**PREVIEW:** Device has been announced but is not in production. Samples may or may not be available.

**OBSOLETE:** TI has discontinued the production of the device.

(2) **RoHS:** TI defines "RoHS" to mean semiconductor products that are compliant with the current EU RoHS requirements for all 10 RoHS substances, including the requirement that RoHS substance do not exceed 0.1% by weight in homogeneous materials. Where designed to be soldered at high temperatures, "RoHS" products are suitable for use in specified lead-free processes. TI may reference these types of products as "Pb-Free".

**RoHS Exempt:** TI defines "RoHS Exempt" to mean products that contain lead but are compliant with EU RoHS pursuant to a specific EU RoHS exemption.

**Green:** TI defines "Green" to mean the content of Chlorine (Cl) and Bromine (Br) based flame retardants meet JS709B low halogen requirements of <=1000ppm threshold. Antimony trioxide based flame retardants must also meet the <=1000ppm threshold requirement.

(3) MSL, Peak Temp. - The Moisture Sensitivity Level rating according to the JEDEC industry standard classifications, and peak solder temperature.

(4) There may be additional marking, which relates to the logo, the lot trace code information, or the environmental category on the device.

(5) Multiple Device Markings will be inside parentheses. Only one Device Marking contained in parentheses and separated by a "~" will appear on a device. If a line is indented then it is a continuation of the previous line and the two combined represent the entire Device Marking for that device.

(6) Lead finish/Ball material - Orderable Devices may have multiple material finish options. Finish options are separated by a vertical ruled line. Lead finish/Ball material values may wrap to two lines if the finish value exceeds the maximum column width.

**Important Information and Disclaimer:**The information provided on this page represents TI's knowledge and belief as of the date that it is provided. TI bases its knowledge and belief on information provided by third parties, and makes no representation or warranty as to the accuracy of such information. Efforts are underway to better integrate information from third parties. TI has taken and continues to take reasonable steps to provide representative and accurate information but may not have conducted destructive testing or chemical analysis on incoming materials and chemicals. TI and TI suppliers consider certain information to be proprietary, and thus CAS numbers and other limited information may not be available for release.

In no event shall TI's liability arising out of such information exceed the total purchase price of the TI part(s) at issue in this document sold by TI to Customer on an annual basis.



**TAPE AND REEL INFORMATION**

**QUADRANT ASSIGNMENTS FOR PIN 1 ORIENTATION IN TAPE**

\*All dimensions are nominal

Device	Package Type	Package Drawing	Pins	SPQ	Reel Diameter (mm)	Reel Width W1 (mm)	A0 (mm)	B0 (mm)	K0 (mm)	P1 (mm)	W (mm)	Pin1 Quadrant
TPS2547RTER	WQFN	RTE	16	3000	330.0	12.4	3.3	3.3	1.1	8.0	12.0	Q2
TPS2547RTET	WQFN	RTE	16	250	180.0	12.4	3.3	3.3	1.1	8.0	12.0	Q2

**TAPE AND REEL BOX DIMENSIONS**

\*All dimensions are nominal

Device	Package Type	Package Drawing	Pins	SPQ	Length (mm)	Width (mm)	Height (mm)
TPS2547RTER	WQFN	RTE	16	3000	367.0	367.0	35.0
TPS2547RTET	WQFN	RTE	16	250	210.0	185.0	35.0

## GENERIC PACKAGE VIEW

**RTE 16**

**WQFN - 0.8 mm max height**

3 x 3, 0.5 mm pitch

PLASTIC QUAD FLATPACK - NO LEAD

This image is a representation of the package family, actual package may vary.  
Refer to the product data sheet for package details.

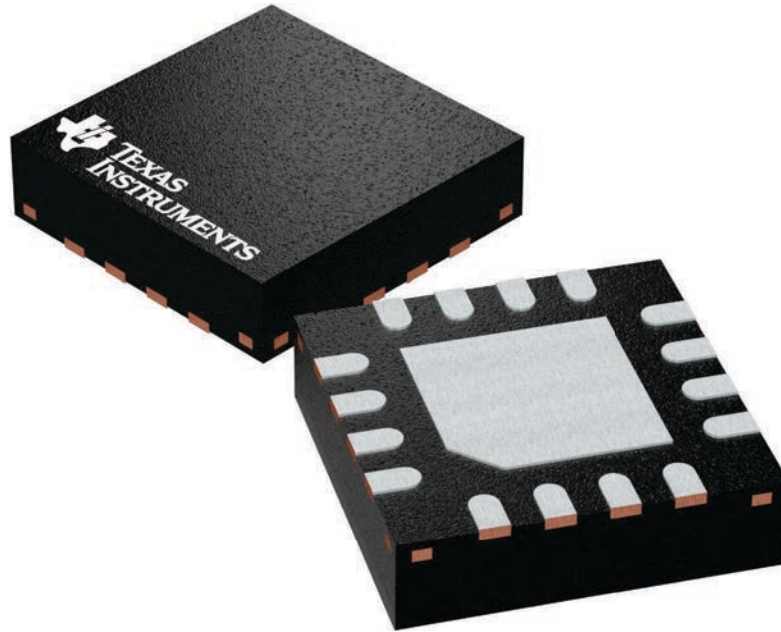

4225944/A

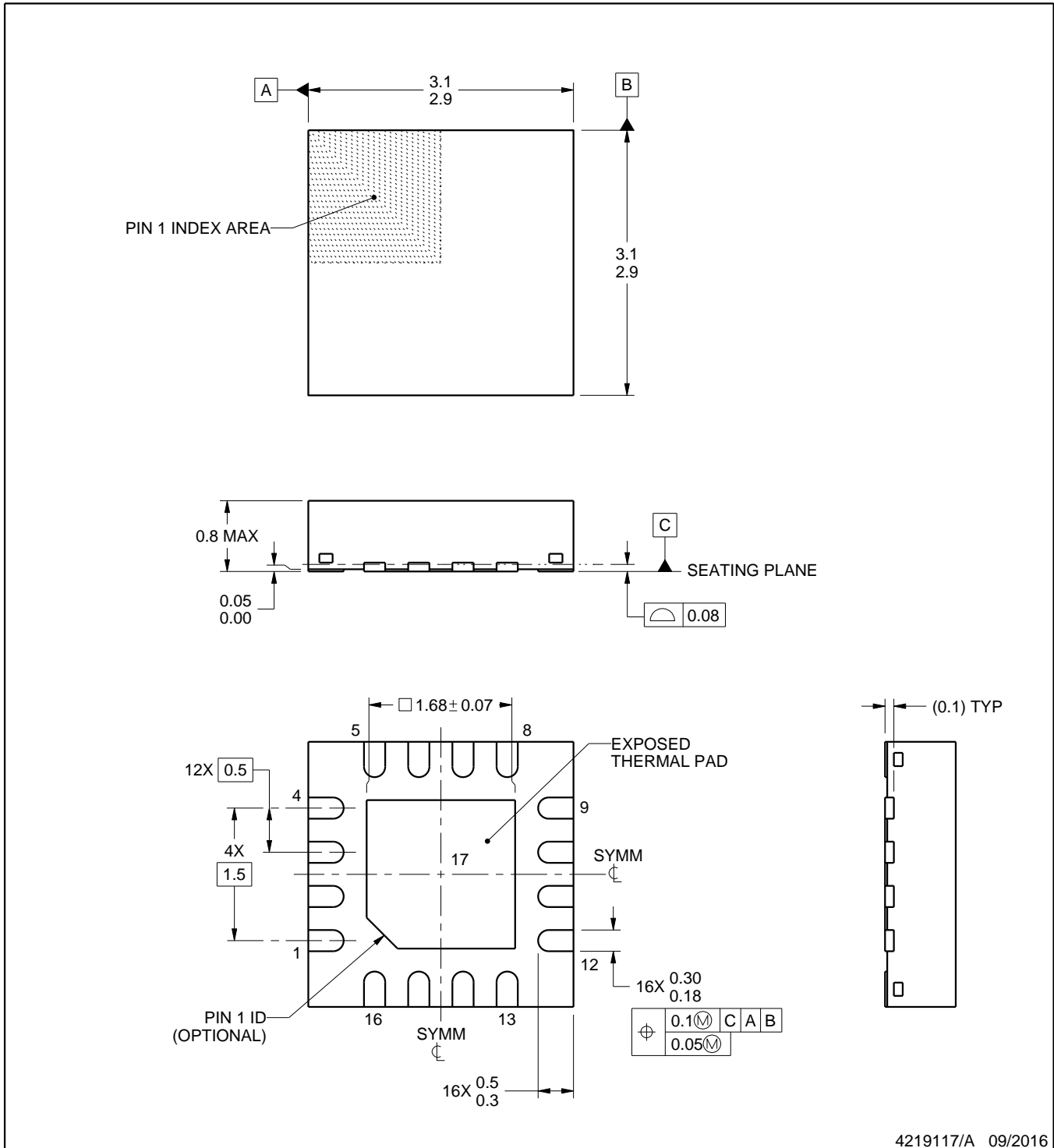

NOTES:

1. All linear dimensions are in millimeters. Any dimensions in parenthesis are for reference only. Dimensioning and tolerancing per ASME Y14.5M.
2. This drawing is subject to change without notice.
3. The package thermal pad must be soldered to the printed circuit board for thermal and mechanical performance.

# EXAMPLE BOARD LAYOUT

RTE0016C

WQFN - 0.8 mm max height

PLASTIC QUAD FLATPACK - NO LEAD

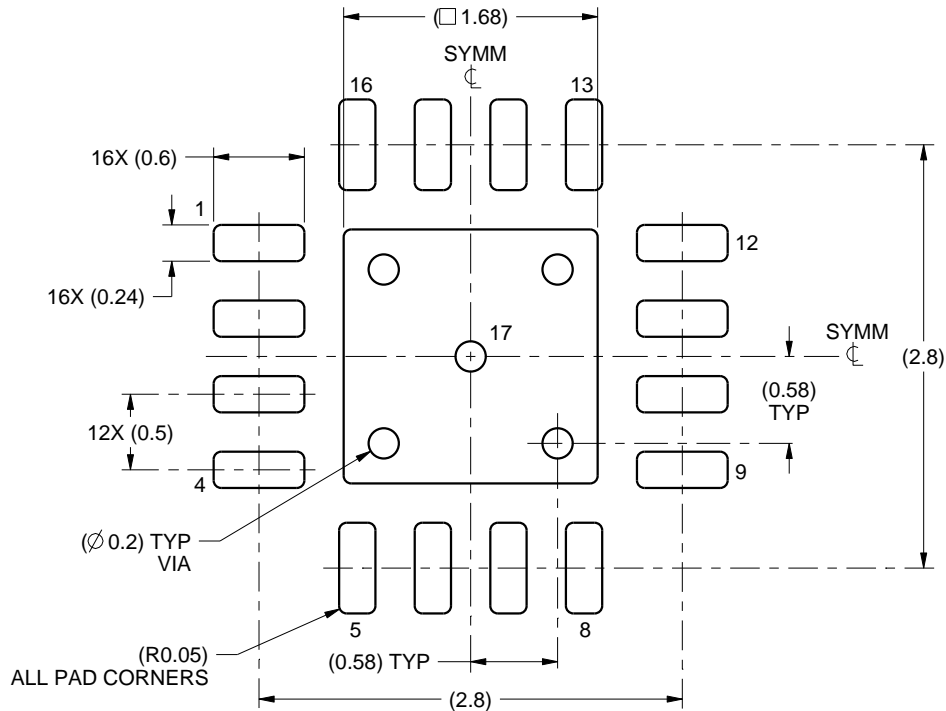

LAND PATTERN EXAMPLE  
SCALE:20X

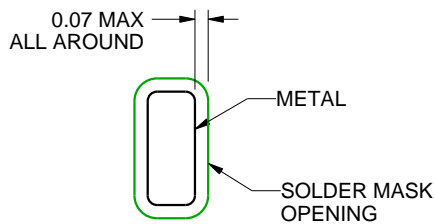

NON SOLDER MASK  
DEFINED  
(PREFERRED)

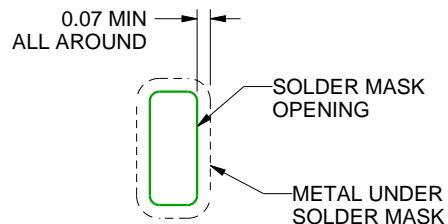

SOLDER MASK  
DEFINED

## SOLDER MASK DETAILS

4219117/A 09/2016

NOTES: (continued)

- This package is designed to be soldered to a thermal pad on the board. For more information, see Texas Instruments literature number SLUA271 ([www.ti.com/lit/slua271](http://www.ti.com/lit/slua271)).
- Vias are optional depending on application, refer to device data sheet. If any vias are implemented, refer to their locations shown on this view. It is recommended that vias under paste be filled, plugged or tented.

# EXAMPLE STENCIL DESIGN

RTE0016C

WQFN - 0.8 mm max height

PLASTIC QUAD FLATPACK - NO LEAD

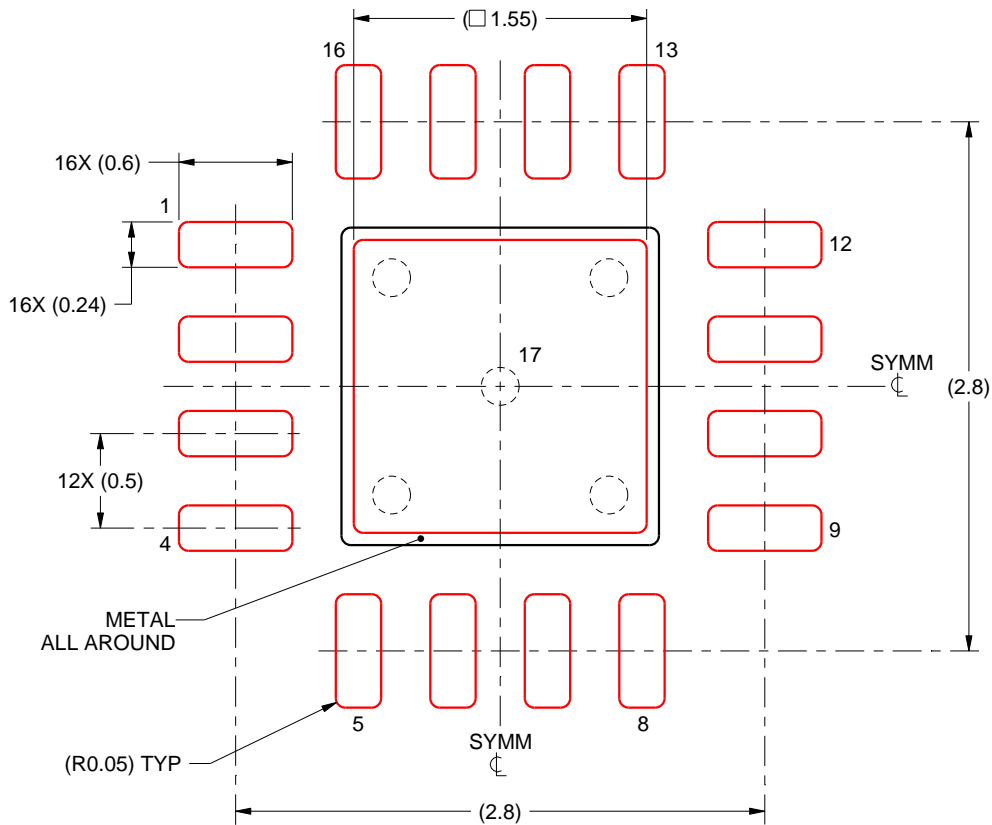

**SOLDER PASTE EXAMPLE**  
BASED ON 0.125 mm THICK STENCIL

EXPOSED PAD 17:  
85% PRINTED SOLDER COVERAGE BY AREA UNDER PACKAGE  
SCALE:25X

4219117/A 09/2016

NOTES: (continued)

6. Laser cutting apertures with trapezoidal walls and rounded corners may offer better paste release. IPC-7525 may have alternate design recommendations.

## 重要声明和免责声明

TI“按原样”提供技术和可靠性数据（包括数据表）、设计资源（包括参考设计）、应用或其他设计建议、网络工具、安全信息和其他资源，不保证没有瑕疵且不做任何明示或暗示的担保，包括但不限于对适销性、某特定用途方面的适用性或不侵犯任何第三方知识产权的暗示担保。

这些资源可供使用 TI 产品进行设计的熟练开发人员使用。您将自行承担以下全部责任：(1) 针对您的应用选择合适的 TI 产品，(2) 设计、验证并测试您的应用，(3) 确保您的应用满足相应标准以及任何其他功能安全、信息安全、监管或其他要求。

这些资源如有变更，恕不另行通知。TI 授权您仅可将这些资源用于研发本资源所述的 TI 产品的应用。严禁对这些资源进行其他复制或展示。您无权使用任何其他 TI 知识产权或任何第三方知识产权。您应全额赔偿因在这些资源的使用中对 TI 及其代表造成的任何索赔、损害、成本、损失和债务，TI 对此概不负责。

TI 提供的产品受 [TI 的销售条款](#) 或 [ti.com](#) 上其他适用条款/TI 产品随附的其他适用条款的约束。TI 提供这些资源并不会扩展或以其他方式更改 TI 针对 TI 产品发布的适用的担保或担保免责声明。

TI 反对并拒绝您可能提出的任何其他或不同的条款。

邮寄地址：Texas Instruments, Post Office Box 655303, Dallas, Texas 75265

Copyright © 2022，德州仪器 (TI) 公司