

INA250 集成有精密分流电阻的 36V 低侧/高侧双向零漂移分流监视器

1 特性

- 精密的集成分流电阻：
 - 分流电阻: 2mΩ
 - 分流电阻容差: 0.1% (最大值)
 - 15A 持续电流 (-40°C 至 85°C)
 - 0°C 至 125°C 温度系数: 10ppm/°C
- 高精度：
 - 增益误差 (分流和放大器): 0.3% (最大值)
 - 偏移电流: 50mA (最大值, INA250A2)
- 四种增益可供选择：
 - INA250A1: 200mV/A
 - INA250A2: 500mV/A
 - INA250A3: 800mV/A
 - INA250A4: 2V/A
- 宽共模电压范围: -0.1V 至 36V
- 特定工作温度范围: -40°C 至 125°C

2 应用

- 测试设备
- 电源
- 服务器
- 电信设备
- 汽车用
- 太阳能逆变器
- 电源管理

3 说明

INA250 是电压输出、电流感测放大器系列，其集成了一个内部分流电阻，能够在 0V 至 36V 共模电压范围上实现高精度电流测量，并且与电源电压无关。该器件是一款双向、低侧/高侧分流监视器，可使用外部参考来测量双向流入内部电流感测电阻传感器的电流。集成的精密电流感测电阻可使器件获得校准级别的测量精度以及超低温漂，并确保始终可实施针对感测电阻而优化的 Kelvin 布局。

INA250 系列提供四级输出电压: 200mV/A、500mV/A、800mV/A 和 2V/A。该器件已经过完全测试，可在 125°C 最高温度下提供高达 10A 的持续电流。INA250 由一个 2.7V 至 36V 的单电源供电，最大供电电流为 300μA。INA250 的所有增益版本均在扩展工作温度范围 (-40°C 至 +125°C) 内额定运行，并且采用薄型小外形尺寸 (TSSOP)-16 封装。

器件信息⁽¹⁾

器件型号	封装	封装尺寸 (标称值)
INA250A1	TSSOP (16)	5.00mm x 4.40mm
INA250A2		
INA250A3		
INA250A4		

(1) 如需了解所有可用封装，请见数据表末尾的可订购产品附录。

简化电路原理图

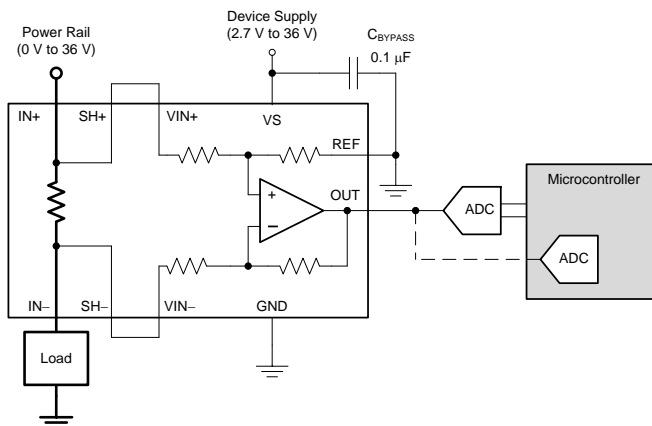

目录

1	特性	1	7.4	Device Functional Modes	15
2	应用	1	8	Applications and Implementation	19
3	说明	1	8.1	Application Information	19
4	修订历史记录	2	8.2	Typical Applications	19
5	Pin Configuration and Functions	3	9	Power Supply Recommendations	23
6	Specifications	4	10	Layout	24
6.1	Absolute Maximum Ratings	4	10.1	Layout Guidelines	24
6.2	ESD Ratings	4	10.2	Layout Examples	24
6.3	Recommended Operating Conditions	4	11	器件和文档支持	26
6.4	Thermal Information	4	11.1	文档支持	26
6.5	Electrical Characteristics	5	11.2	相关链接	26
6.6	Typical Characteristics	7	11.3	社区资源	26
7	Detailed Description	12	11.4	商标	26
7.1	Overview	12	11.5	静电放电警告	26
7.2	Functional Block Diagram	12	11.6	Glossary	26
7.3	Feature Description	12	12	机械、封装和可订购信息	26

4 修订历史记录

Changes from Revision A (May 2015) to Revision B	Page
• 已将 INA250A1、INA250A3 和 INA250A4 发布为量产数据	1
• 已添加 TI 设计	1
• Added parameters for INA250A1, INA250A3, and INA250A4 to <i>Electrical Characteristics</i> table	5
• Added \pm to specifications for the <i>Shunt short time overload</i> , <i>Shunt thermal shock</i> , <i>Shunt resistance to solder heat</i> , <i>Shunt high temperature exposure</i> , and <i>Shunt cold temperature storage</i> parameters of <i>Electrical Characteristics</i> table	5
• Added curves for INA250A1, INA250A3, and INA250A4 to <i>Typical Characteristics</i> section	7
• Added <i>Amplifier Operation</i> section	15
• 添加了社区资源部分	26

Changes from Original (April 2015) to Revision A	Page
• INA250A2 已发布为量产数据	1

5 Pin Configuration and Functions

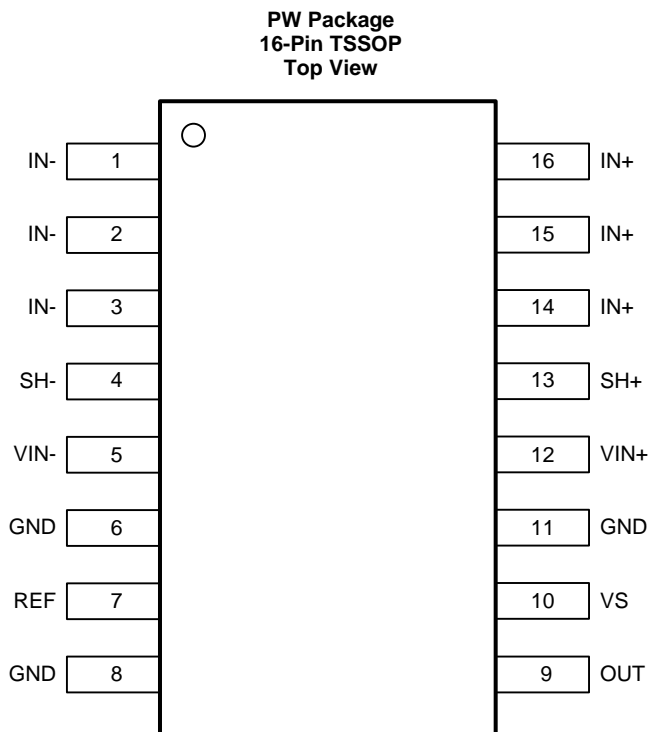

Pin Functions

PIN		I/O	DESCRIPTION
NAME	NO.		
GND	6, 8, 11	Analog	Ground
IN-	1, 2, 3	Analog input	Connect to load
IN+	14, 15, 16	Analog input	Connect to supply
OUT	9	Analog output	Output voltage
REF	7	Analog input	Reference voltage, 0 V to VS (up to 18 V)
SH-	4	Analog output	Kelvin connection to internal shunt. Connect to VIN- if no filtering is needed. See Figure 33 for filter recommendations.
SH+	13	Analog output	Kelvin connection to internal shunt. Connect to VIN+ if no filtering is needed. See Figure 33 for filter recommendations.
VIN-	5	Analog input	Voltage input from load side of shunt resistor.
VIN+	12	Analog input	Voltage input from supply side of shunt resistor.
VS	10	Analog	Device power supply, 2.7 V to 36 V

6 Specifications

6.1 Absolute Maximum Ratings

over operating free-air temperature range (unless otherwise noted)⁽¹⁾

		MIN	MAX	UNIT
Supply voltage (VS)			40	V
Analog input current	Continuous current		±15	A
Analog inputs (IN+, IN–)	Common-mode	GND – 0.3	40	V
Analog inputs (VIN+, VIN–)	Common-mode	GND – 0.3	40	V
	Differential (VIN+) – (VIN–)	–40	40	
Analog inputs (REF)		GND – 0.3	VS + 0.3	V
Analog outputs (SH+, SH–)	Common-mode	GND – 0.3	40	V
Analog outputs (OUT)		GND – 0.3	(VS + 0.3) up to 18	V
Temperature	Operating, TA	–55	150	°C
	Junction, TJ		150	
	Storage, Tstg	–65	150	

(1) Stresses above these ratings may cause permanent damage. Exposure to absolute maximum conditions for extended periods may degrade device reliability. These are stress ratings only, and functional operation of the device at these or any other conditions beyond those specified is not implied.

6.2 ESD Ratings

			VALUE	UNIT
V(ESD)	Electrostatic discharge	Human-body model (HBM), per ANSI/ESDA/JEDEC JS-001 ⁽¹⁾	±2000	V
		Charged-device model (CDM), per JEDEC specification JESD22-C101 ⁽²⁾	±1000	

(1) JEDEC document JEP155 states that 500-V HBM allows safe manufacturing with a standard ESD control process.

(2) JEDEC document JEP157 states that 250-V CDM allows safe manufacturing with a standard ESD control process.

6.3 Recommended Operating Conditions

		MIN	NOM	MAX	UNIT
V _{CM}	Common-mode input voltage	0		36	V
VS	Operating supply voltage	2.7		36	V
TA	Operating free-air temperature	–40		125	°C

6.4 Thermal Information

THERMAL METRIC ⁽¹⁾		INA250	UNIT
		PW (TSSOP)	
		16 PINS	
R _{θJA}	Junction-to-ambient thermal resistance	104.4	°C/W
R _{θJC(top)}	Junction-to-case (top) thermal resistance	42.3	°C/W
R _{θJB}	Junction-to-board thermal resistance	48.5	°C/W
ψ _{JT}	Junction-to-top characterization parameter	4.5	°C/W
ψ _{JB}	Junction-to-board characterization parameter	48	°C/W
R _{θJC(bot)}	Junction-to-case (bottom) thermal resistance	N/A	°C/W

(1) For more information about traditional and new thermal metrics, see the *IC Package Thermal Metrics* application report, [SPRA953](http://www.ti.com/lit/zip/SPRA953).

6.5 Electrical Characteristics

At $T_A = 25^\circ\text{C}$, $V_S = 5\text{ V}$, $V_{IN+} = 12\text{ V}$, $V_{REF} = 2.5\text{ V}$, $I_{SENSE} = I_{IN+} = 0\text{ A}$, unless otherwise noted.

PARAMETER	CONDITIONS	MIN	TYP	MAX	UNIT	
INPUT						
V_{CM}	Common-mode input range	-0.1		36	V	
CMR	Common-mode rejection	INA250A1, $V_{IN+} = 0\text{ V to }36\text{ V}$, $T_A = -40^\circ\text{C to }125^\circ\text{C}$	94	102	dB	
		INA250A2, $V_{IN+} = 0\text{ V to }36\text{ V}$, $T_A = -40^\circ\text{C to }125^\circ\text{C}$	97	110		
		INA250A3, $V_{IN+} = 0\text{ V to }36\text{ V}$, $T_A = -40^\circ\text{C to }125^\circ\text{C}$	106	114		
		INA250A4, $V_{IN+} = 0\text{ V to }36\text{ V}$, $T_A = -40^\circ\text{C to }125^\circ\text{C}$	108	118		
I_{OS}	Offset current, RTI ⁽¹⁾	INA250A1, $I_{SENSE} = 0\text{ A}$		± 15	± 100	mA
		INA250A2, $I_{SENSE} = 0\text{ A}$		± 12.5	± 50	
		INA250A3, $I_{SENSE} = 0\text{ A}$		± 5	± 30	
		INA250A4, $I_{SENSE} = 0\text{ A}$		± 5	± 20	
dI_{OS}/dT	RTI versus temperature	$T_A = -40^\circ\text{C to }125^\circ\text{C}$		25	250	$\mu\text{A}/^\circ\text{C}$
PSR		$V_S = 2.7\text{ V to }36\text{ V}$, $T_A = -40^\circ\text{C to }125^\circ\text{C}$		± 0.03	± 1	mA/V
I_B	Input bias current	I_{B+} , I_{B-} , $I_{SENSE} = 0\text{ A}$		± 28	± 35	μA
V_{REF}	Reference input range ⁽²⁾	0		(V_S) up to 18	V	
SHUNT RESISTOR⁽³⁾						
R_{SHUNT}	Shunt resistance (SH+ to SH-)	Equivalent resistance when used with onboard amplifier	1.998	2	2.002	m Ω
		Used as stand-alone resistor ⁽⁴⁾	1.9	2	2.1	
	Package resistance	IN+ to IN-		4.5		m Ω
	Resistor temperature coefficient	$T_A = -40^\circ\text{C to }125^\circ\text{C}$		15	ppm/ $^\circ\text{C}$	
		$T_A = -40^\circ\text{C to }0^\circ\text{C}$		50		
		$T_A = 0^\circ\text{C to }125^\circ\text{C}$		10		
I_{SENSE}	Maximum continuous current ⁽⁵⁾	$T_A = -40^\circ\text{C to }85^\circ\text{C}$			± 15	A
	Shunt short time overload	$I_{SENSE} = 30\text{ A for }5\text{ seconds}$		$\pm 0.05\%$		
	Shunt thermal shock	$-65^\circ\text{C to }150^\circ\text{C}$, 500 cycles		$\pm 0.1\%$		
	Shunt resistance to solder heat	260 $^\circ\text{C}$ solder, 10 s		$\pm 0.1\%$		
	Shunt high temperature exposure	1000 hours, $T_A = 150^\circ\text{C}$		$\pm 0.15\%$		
	Shunt cold temperature storage	24 hours, $T_A = -65^\circ\text{C}$		$\pm 0.025\%$		

(1) RTI = referred-to-input.

(2) The supply voltage range maximum is 36 V, but the reference voltage cannot be higher than 18 V.

(3) See the [Integrated Shunt Resistor](#) section for additional information regarding the integrated current-sensing resistor.

(4) The internal shunt resistor is intended to be used with the internal amplifier and is not intended to be used as a stand-alone resistor. See the [Integrated Shunt Resistor](#) section for more information.

(5) See [Figure 30](#) and the [Layout](#) section for additional information on the current derating and layout recommendations to improve the current handling capability of the device at higher temperatures.

Electrical Characteristics (continued)

 At $T_A = 25^\circ\text{C}$, $V_S = 5\text{ V}$, $V_{IN+} = 12\text{ V}$, $V_{REF} = 2.5\text{ V}$, $I_{SENSE} = I_{IN+} = 0\text{ A}$, unless otherwise noted.

PARAMETER		CONDITIONS	MIN	TYP	MAX	UNIT
OUTPUT						
G	Gain	INA250A1		200		mV/A
		INA250A2		500		
		INA250A3		800		
		INA250A4		2		V/A
	System gain error ⁽⁶⁾	$I_{SENSE} = -10\text{ A to }10\text{ A}$, $T_A = 25^\circ\text{C}$		$\pm 0.05\%$	$\pm 0.3\%$	ppm/ $^\circ\text{C}$
		$I_{SENSE} = -10\text{ A to }10\text{ A}$, $T_A = -40^\circ\text{C to }125^\circ\text{C}$			$\pm 0.75\%$	
		$T_A = -40^\circ\text{C to }125^\circ\text{C}$			45	
	Nonlinearity error	$I_{SENSE} = 0.5\text{ A to }10\text{ A}$		$\pm 0.03\%$		
R_O	Output impedance			1.5		Ω
	Maximum capacitive load	No sustained oscillation		1		nF
VOLTAGE OUTPUT⁽⁷⁾						
	Swing to V_S power-supply rail	$R_L = 10\text{ k}\Omega$ to GND		$(V_S) - 0.1$	$(V_S) - 0.2$	V
	Swing to GND	$R_L = 10\text{ k}\Omega$ to GND		$(V_{GND}) + 25$	$(V_{GND}) + 50$	mV
FREQUENCY RESPONSE						
BW	Bandwidth	INA250A1, $C_L = 10\text{ pF}$		50		kHz
		INA250A2, $C_L = 10\text{ pF}$		50		
		INA250A3, $C_L = 10\text{ pF}$		35		
		INA250A4, $C_L = 10\text{ pF}$		11		
SR	Slew rate	$C_L = 10\text{ pF}$		0.2		V/ μs
NOISE, RTI⁽¹⁾						
	Voltage noise density	INA250A1		51		nV/ $\sqrt{\text{Hz}}$
		INA250A2		35		
		INA250A3		37		
		INA250A4		27		
POWER SUPPLY						
V_S	Operating voltage range		2.7		36	V
I_Q	Quiescent current	$T_A = -40^\circ\text{C to }125^\circ\text{C}$		200	300	μA
TEMPERATURE RANGE						
	Specified range		-40		125	$^\circ\text{C}$

(6) System gain error includes amplifier gain error and the integrated sense resistor tolerance. System gain error does not include the stress related characteristics of the integrated sense resistor. These characteristics are described in the [Shunt Resistor](#) section of the [Electrical Characteristics](#) table.

(7) See *Typical Characteristics* curve, *Output Voltage Swing vs Output Current* (Figure 19).

6.6 Typical Characteristics

At $T_A = 25^\circ\text{C}$, $V_S = 5\text{ V}$, $V_{IN+} = 12\text{ V}$, $V_{REF} = 2.5\text{ V}$, $I_{SENSE} = I_{IN+} = 0\text{ A}$, unless otherwise noted.

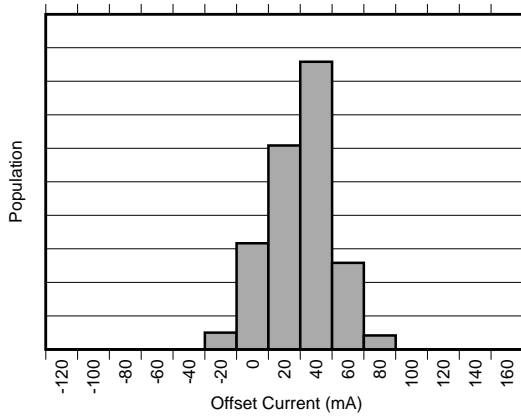

Figure 1. INA250A1 Input Offset Distribution

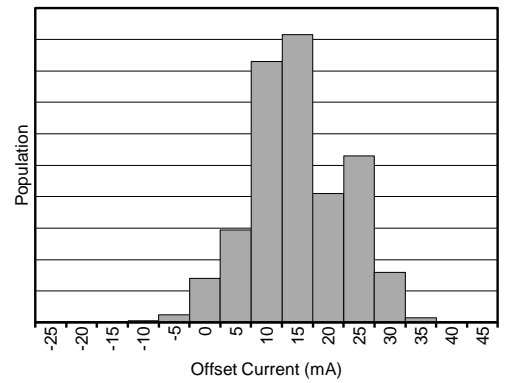

Figure 2. INA250A2 Input Offset Distribution

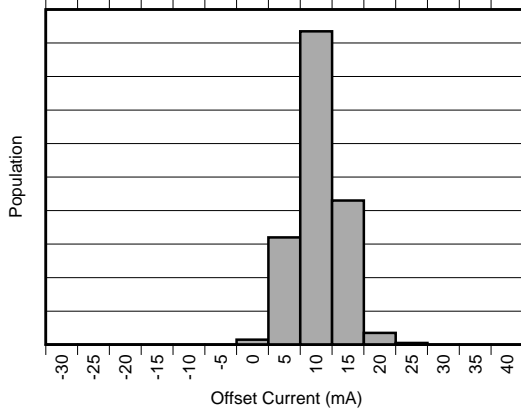

Figure 3. INA250A3 Input Offset Distribution

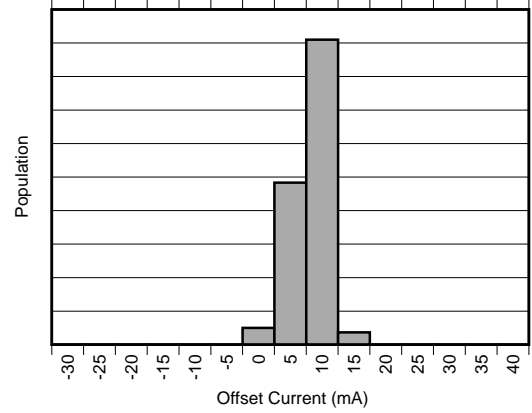

Figure 4. INA250A4 Input Offset Distribution

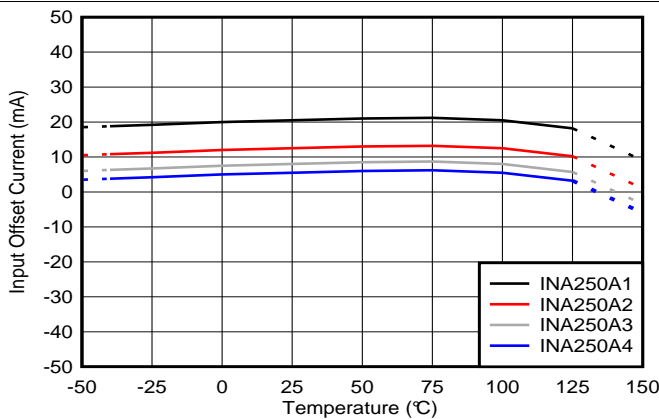

Figure 5. Input Offset vs Temperature

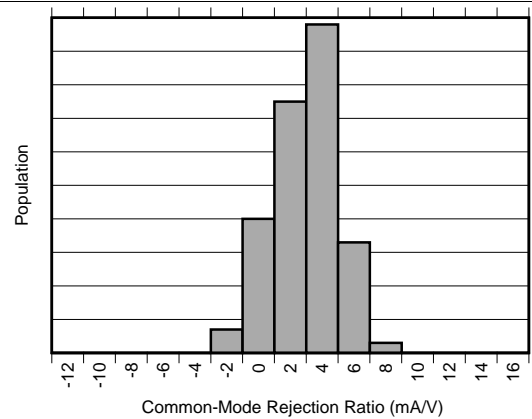

Figure 6. INA250A1 Common-Mode Rejection Ratio Distribution

Typical Characteristics (continued)

At $T_A = 25^\circ\text{C}$, $V_S = 5\text{ V}$, $V_{IN+} = 12\text{ V}$, $V_{REF} = 2.5\text{ V}$, $I_{SENSE} = I_{IN+} = 0\text{ A}$, unless otherwise noted.

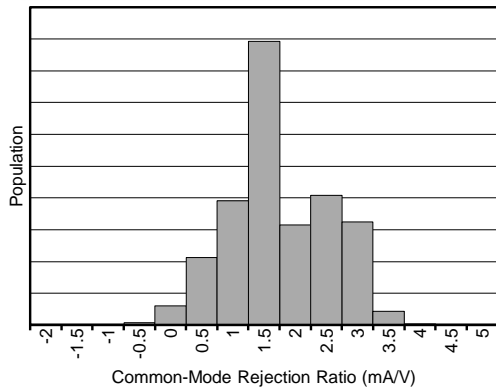

Figure 7. INA250A2 Common-Mode Rejection Ratio Distribution

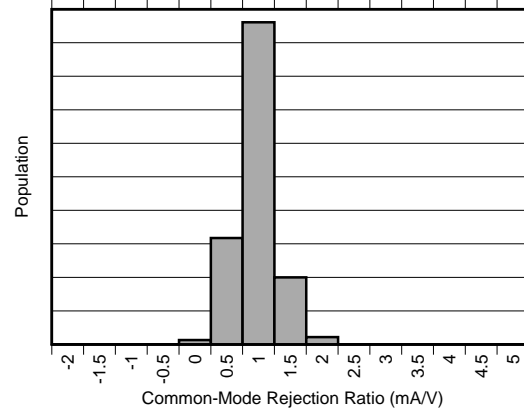

Figure 8. INA250A3 Common-Mode Rejection Ratio Distribution

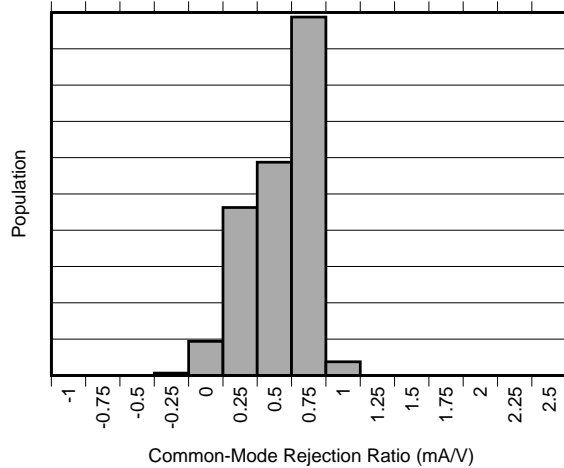

Figure 9. INA250A4 Common-Mode Rejection Ratio Distribution

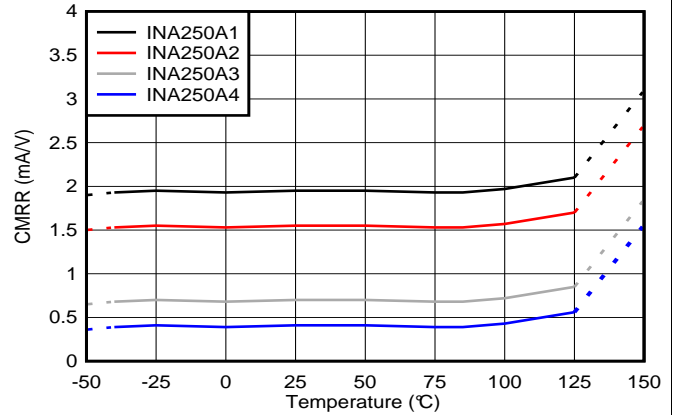

Figure 10. Common-Mode Rejection Ratio vs Temperature

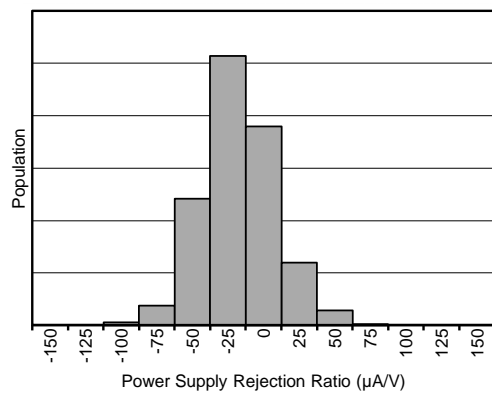

Figure 11. Power-Supply Rejection Ratio Distribution

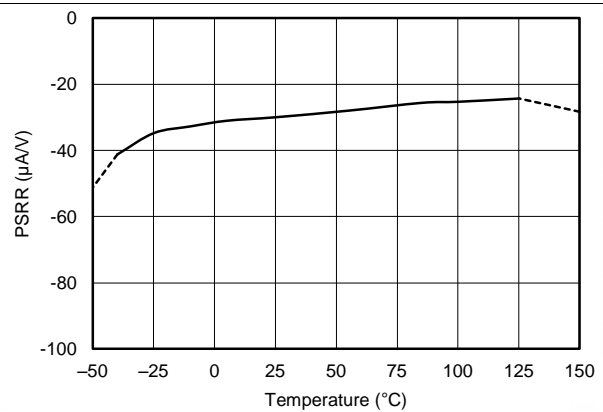

Figure 12. Power-Supply Rejection Ratio vs Temperature

Typical Characteristics (continued)

At $T_A = 25^\circ\text{C}$, $V_S = 5\text{ V}$, $V_{IN+} = 12\text{ V}$, $V_{REF} = 2.5\text{ V}$, $I_{SENSE} = I_{IN+} = 0\text{ A}$, unless otherwise noted.

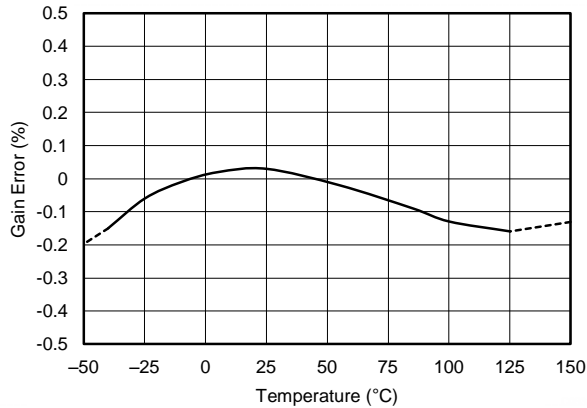

Figure 13. System Gain Error vs Temperature

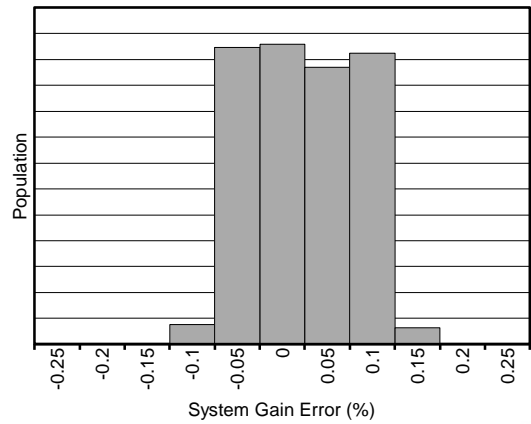

Figure 14. System Gain Error Distribution
System gain error = R_{SHUNT} error + amplifier gain error, load current = 10 A

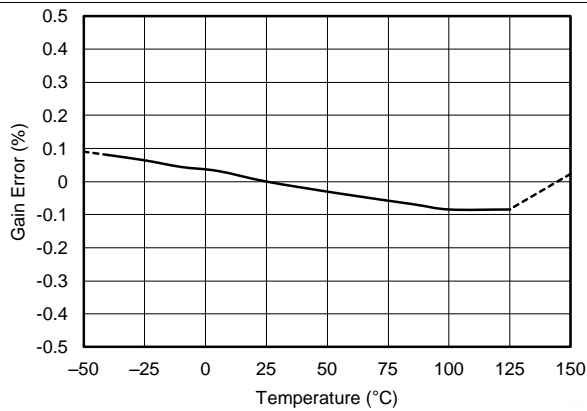

Figure 15. Amplifier Gain Error vs Temperature

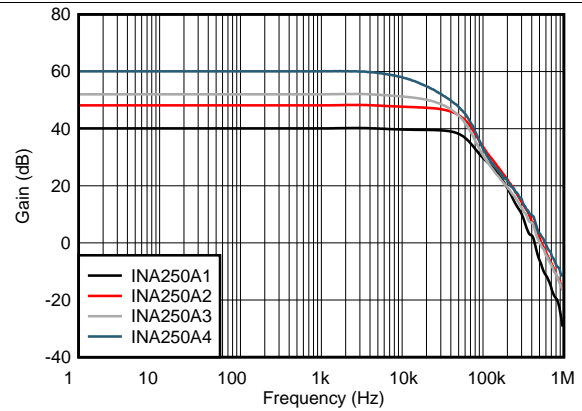

Figure 16. Amplifier Gain vs Frequency
 $V_{CM} = 12\text{ V}$, $I_{SENSE} = 500\text{ mA}_{PP}$

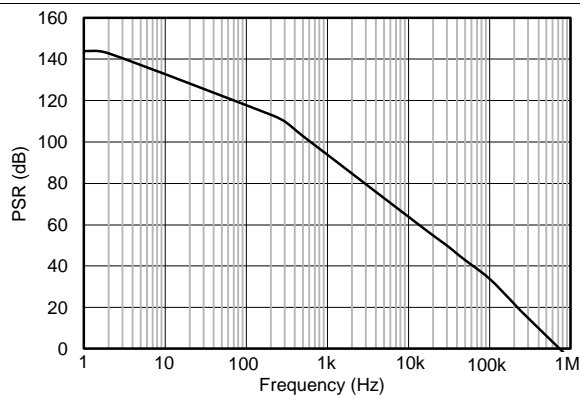

Figure 17. Power-Supply Rejection vs Frequency
 $V_{CM} = 12\text{ V}$, $V_{REF} = 2.5\text{ V}$, $I_{SENSE} = 0\text{ A}$,
 $V_S = 5\text{ V} + 250\text{-mV sine disturbance}$

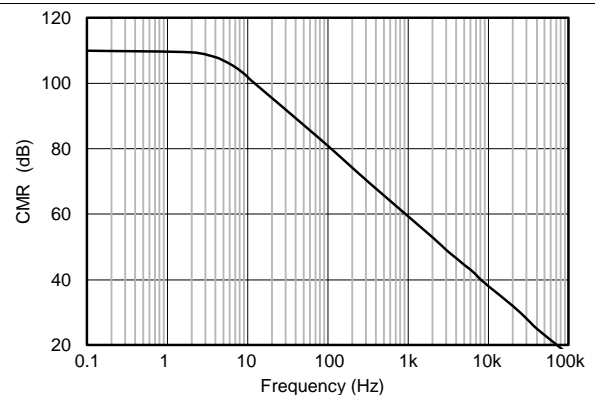
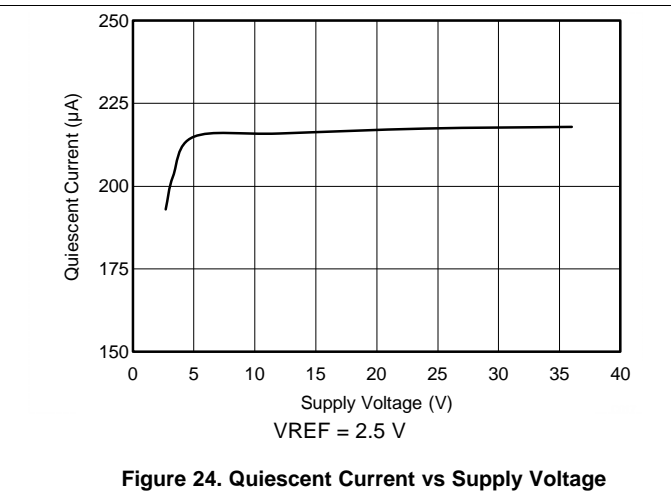
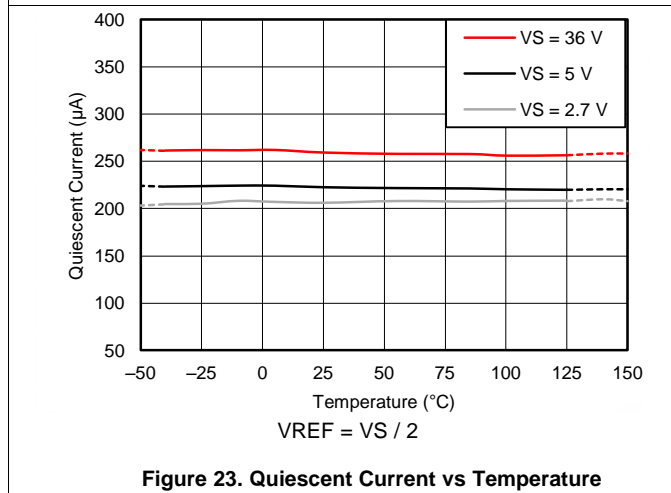
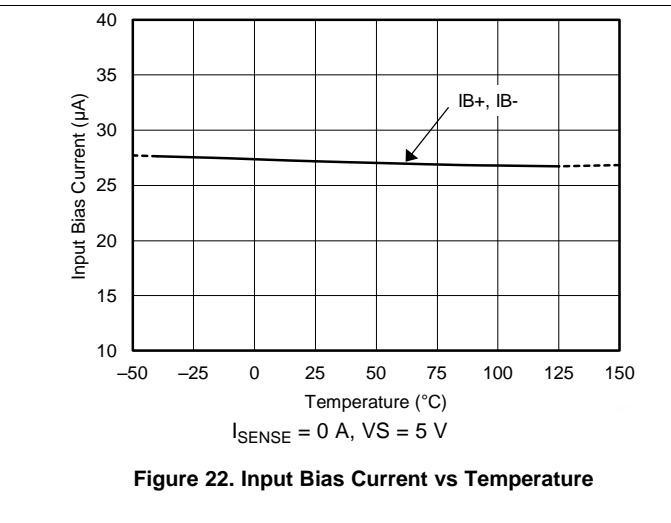
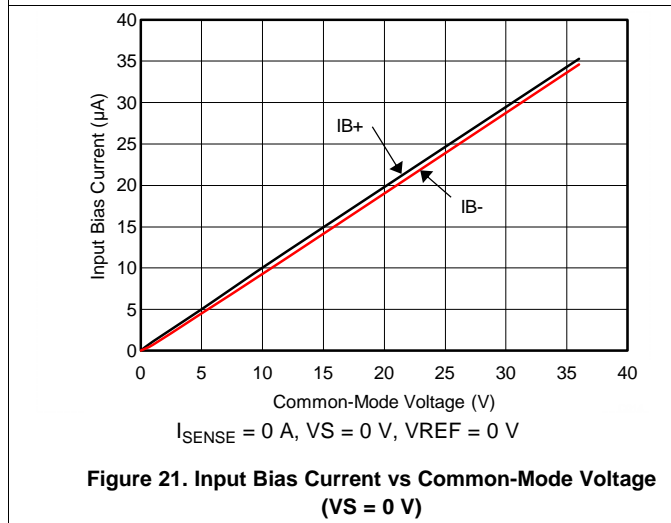
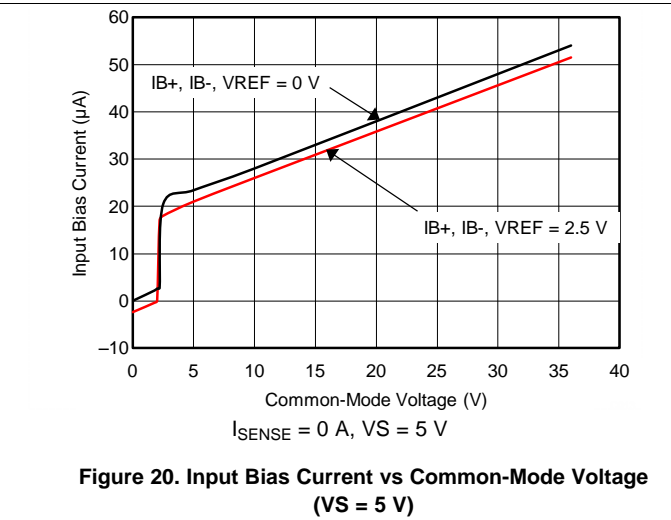
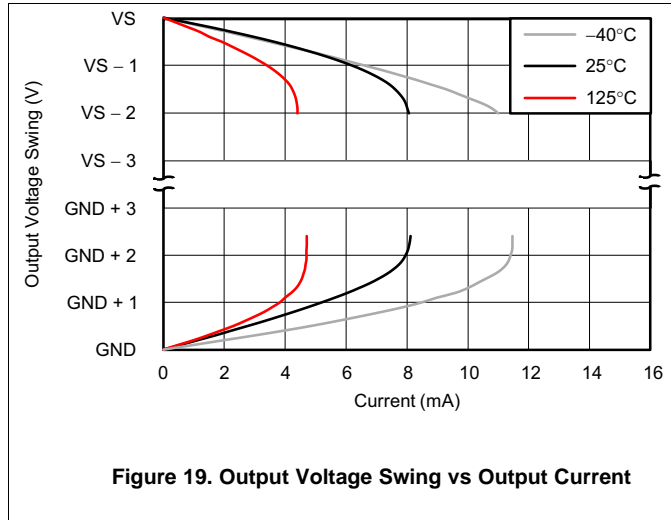

Figure 18. Common-Mode Rejection vs Frequency
 $V_S = 5\text{ V}$, $V_{REF} = 2.5\text{ V}$, $I_{SENSE} = 0\text{ A}$, $V_{CM} = 1\text{-V sine wave}$

Typical Characteristics (continued)

At $T_A = 25^\circ\text{C}$, $V_S = 5\text{ V}$, $V_{IN+} = 12\text{ V}$, $V_{REF} = 2.5\text{ V}$, $I_{SENSE} = I_{IN+} = 0\text{ A}$, unless otherwise noted.



Typical Characteristics (continued)

At $T_A = 25^\circ\text{C}$, $V_S = 5\text{ V}$, $V_{IN+} = 12\text{ V}$, $V_{REF} = 2.5\text{ V}$, $I_{SENSE} = I_{IN+} = 0\text{ A}$, unless otherwise noted.

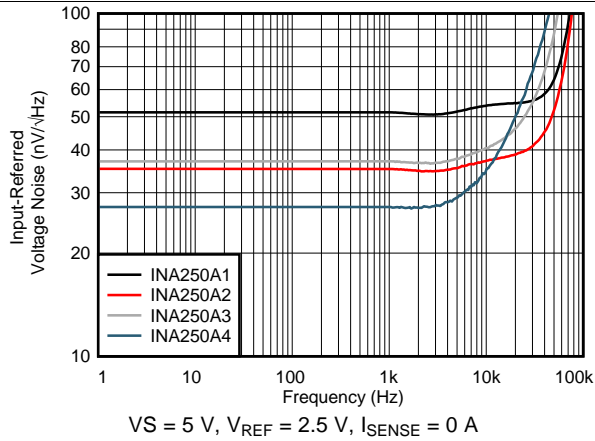

Figure 25. Input-Referred Voltage Noise vs Frequency

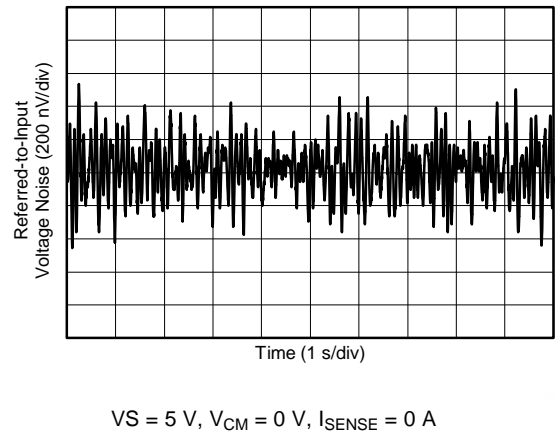

Figure 26. 0.1-Hz to 10-Hz Voltage Noise (Referred-to-Input)

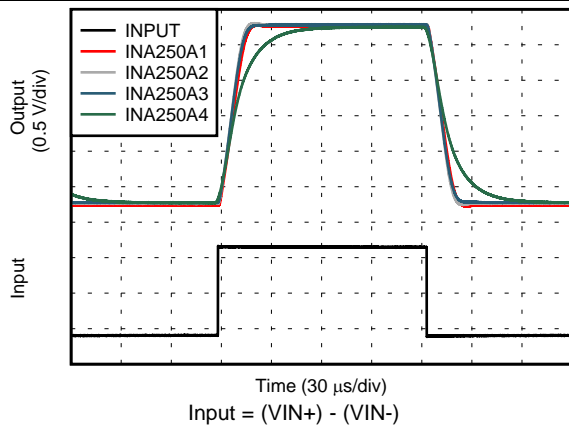

Figure 27. Step Response

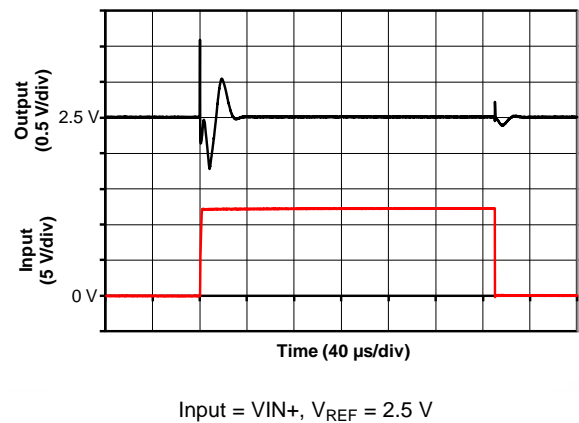

Figure 28. Common-Mode Transient Response

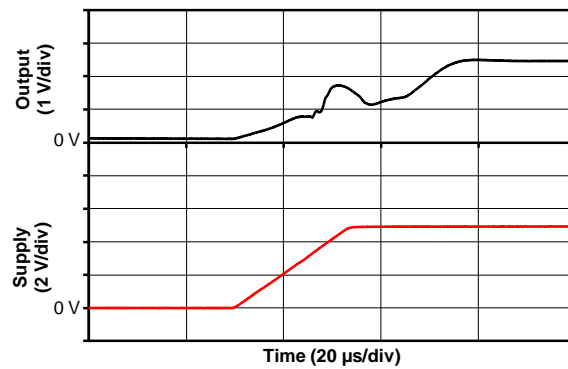

Figure 29. Start-Up Response

7 Detailed Description

7.1 Overview

The INA250 features a 2-m Ω , precision, current-sensing resistor and a 36-V common-mode, zero-drift topology, precision, current-sensing amplifier integrated into a single package. High precision measurements are enabled through the matching of the shunt resistor value and the current-sensing amplifier gain providing a highly-accurate, system-calibrated solution. Multiple gain versions are available to allow for the optimization of the desired full-scale output voltage based on the target current range expected in the application.

7.2 Functional Block Diagram

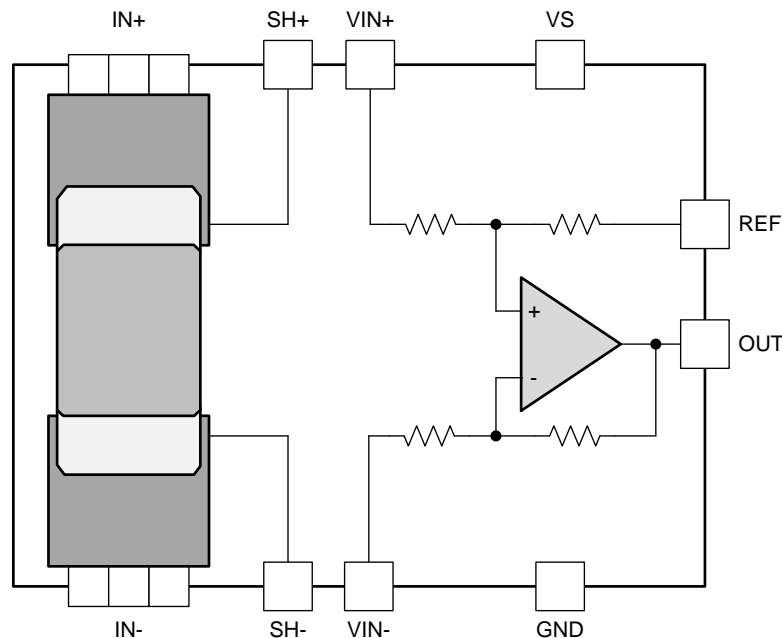

7.3 Feature Description

7.3.1 Integrated Shunt Resistor

The INA250 features a precise, low-drift, current-sensing resistor to allow for precision measurements over the entire specified temperature range of -40°C to 125°C . The integrated current-sensing resistor ensures measurement stability over temperature as well as improving layout and board constraint difficulties common in high precision measurements.

The onboard current-sensing resistor is designed as a 4-wire (or Kelvin) connected resistor that enables accurate measurements through a force-sense connection. Connecting the amplifier inputs pins (VIN $-$ and VIN $+$) to the sense pins of the shunt resistor (SH $-$ and SH $+$) eliminates many of the parasitic impedances commonly found in typical very-low sensing-resistor level measurements. Although the sense connection of the current-sensing resistor can be accessed via the SH $+$ and SH $-$ pins, this resistor is not intended to be used as a stand-alone component. The INA250 is system-calibrated to ensure that the current-sensing resistor and current-sensing amplifier are both precisely matched to one another. Use of the shunt resistor without the onboard amplifier results in a current-sensing resistor tolerance of approximately 5%. To achieve the optimized system gain specification, the onboard sensing resistor must be used with the internal current-sensing amplifier.

Feature Description (continued)

The INA250 has approximately 4.5 mΩ of package resistance. 2 mΩ of this total package resistance is a precisely-controlled resistance from the Kelvin-connected current-sensing resistor used by the amplifier. The power dissipation requirements of the system and package are based on the total 4.5-mΩ package resistance between the IN+ and IN– pins. The heat dissipated across the package when current flows through the device ultimately determines the maximum current that can be safely handled by the package. The current consumption of the silicon is relatively low, leaving the total package resistance carrying the high load current as the primary contributor to the total power dissipation of the package. The maximum safe-operating current level is set to ensure that the heat dissipated across the package is limited so that no damage to the resistor or the package itself occurs or that the internal junction temperature of the silicon does not exceed a 150°C limit.

External factors (such as ambient temperature, external air flow, and PCB layout) can contribute to how effectively the heat developed as a result of the current flowing through the total package resistance can be removed from within the device. Under the conditions of no air flow, a maximum ambient temperature of 85°C, and 1-oz. copper input power planes, the INA250 can accommodate continuous current levels up to 15 A. As shown in Figure 30, the current handling capability is derated at temperatures above the 85°C level with safe operation up to 10 A at a 125°C ambient temperature. With air flow and larger 2-oz. copper input power planes, the INA250 can safely accommodate continuous current levels up to 15 A over the entire –40°C to 125°C temperature range.

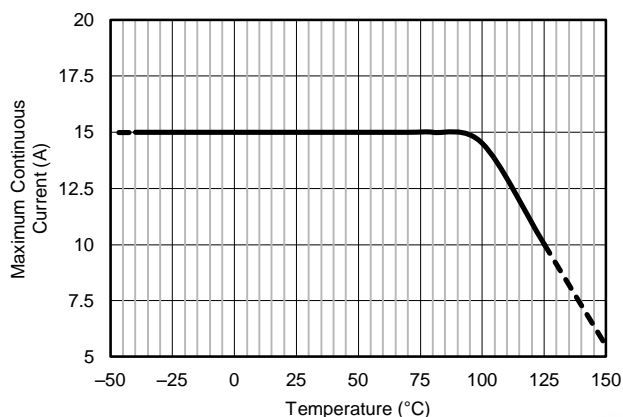

Figure 30. Maximum Current vs Temperature

7.3.2 Short-Circuit Duration

The INA250 features a physical shunt resistance that is able to withstand current levels higher than the continuous handling limit of 15 A without sustaining damage to the current-sensing resistor or the current-sensing amplifier if the excursions are very brief. Figure 31 shows the short-circuit duration curve for the INA250.

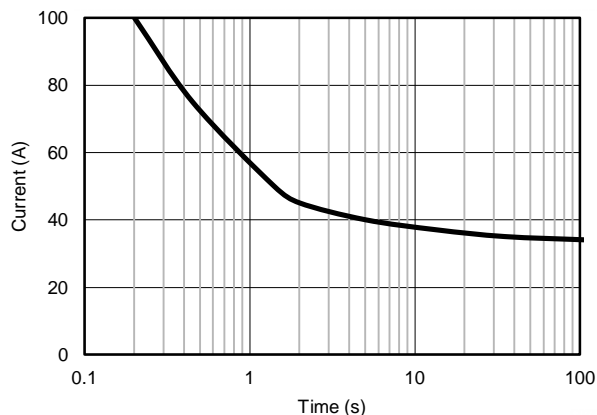

Figure 31. Short-Circuit Duration

Feature Description (continued)

7.3.3 Temperature Stability

System calibration is common for many industrial applications to eliminate initial component and system-level errors that can be present. A system-level calibration can reduce the initial accuracy requirement for many of the individual components because the errors associated with these components are effectively eliminated through the calibration procedure. Performing this calibration can enable precision measurements at the temperature in which the system is calibrated, but as the system temperature changes as a result of external ambient changes or due to self heating, measurement errors are reintroduced. Without accurate temperature compensation used in addition to the initial adjustment, the calibration procedure is not effective in accounting for these temperature-induced changes. One of the primary benefits of the very low temperature coefficient of the INA250 (including both the integrated current-sensing resistor and current-sensing amplifier) is ensuring that the device measurement remains highly accurate, even when the temperature changes throughout the specified temperature range of the device.

For the integrated current-sensing resistor, the drift performance is shown in [Figure 32](#). Although several temperature ranges are specified in the [Electrical Characteristics](#) table, applications operating in ranges other than those described can use [Figure 32](#) to determine how much variance in the shunt resistor value can be expected. As with any resistive element, the tolerance of the component varies when exposed to different temperature conditions. For the current-sensing resistor integrated in the INA250, the resistor does vary slightly more when operated in temperatures ranging from -40°C to 0°C than when operated from 0°C to 125°C . However, even in the -40°C to 0°C temperature range, the drift is still quite low at 25 ppm/ $^{\circ}\text{C}$.

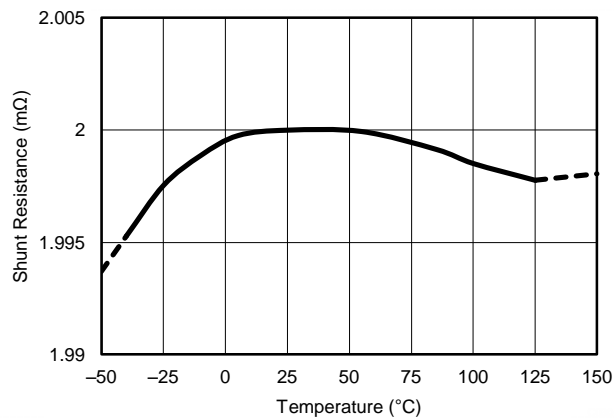

Figure 32. Sensing Resistor vs Temperature

An additional aspect to consider is that when current flows through the current-sensing resistor, power is dissipated across this component. This dissipated power results in an increase in the internal temperature of the package, including the integrated sensing resistor. This resistor self-heating effect results in an increase of the resistor temperature helping to move the component out of the colder, wider drift temperature region.

7.4 Device Functional Modes

7.4.1 Amplifier Operation

The INA250 current-sense amplifier can be configured to measure both unidirectional and bidirectional currents through the reference voltage level applied to the reference pin, REF. The reference voltage connected to REF sets the output level that corresponds with a zero input current condition. For unidirectional operation, tie the REF pin to ground so that when the current increases, the output signal also increases upwards from this reference voltage (or ground in this case). For bidirectional currents, an external voltage source can be used as the reference voltage connected to the REF pin to bias up the output. Set the reference voltage to enable sufficient range above and below this level based on the expected current range to be measured. Positive currents result in an output signal that increases from the zero-current output level set by the reference voltage whereas negative currents result in an output signal that decreases.

For both unidirectional and bidirectional applications, the amplifier transfer function is shown in [Equation 1](#):

$$V_{OUT} = (I_{LOAD} \times GAIN) + V_{REF}$$

where:

- I_{LOAD} is the current being measured passing through the internal shunt resistor,
 - GAIN is the corresponding gain (mA/V) of the selected device, and
 - V_{REF} is the voltage applied to the REF pin
- (1)

As with any difference amplifier, the INA250 common-mode rejection ratio is affected by any impedance present at the REF input. This concern is not a problem when the REF pin is connected directly to a reference or power supply. When using resistive dividers from a power supply or a reference voltage, buffer the REF pin with an op amp.

7.4.2 Input Filtering

An obvious and straightforward location for filtering is at the device output; however, this location negates the advantage of the low output impedance of the output stage buffer. The input then represents the best location for implementing external filtering. [Figure 33](#) shows the typical implementation of the input filter for the device.

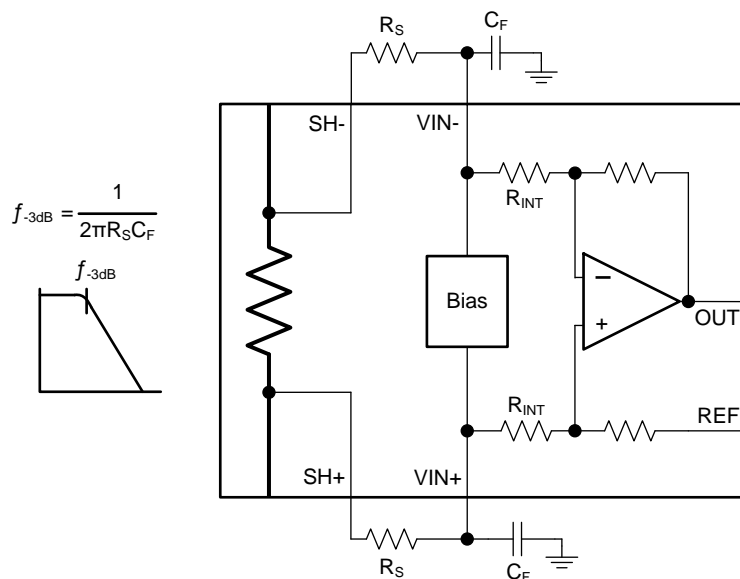

Figure 33. Input Filter

Device Functional Modes (continued)

The addition of external series resistance at the input pins to the amplifier, however, creates an additional error in the measurement. Keep the value of these series resistors to 10 Ω or less, if possible, to reduce the affect to accuracy. The internal bias network illustrated in [Figure 33](#) present at the input pins creates a mismatch in input bias currents when a differential voltage is applied between the input pins, as shown in [Figure 34](#).

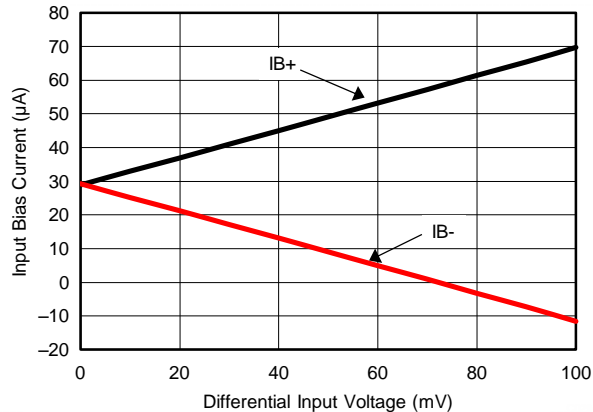

Figure 34. Input Bias Current vs Differential Input Voltage

7.4.2.1 Calculating Gain Error Resulting from External Filter Resistance

If additional external series filter resistors are added to the circuit, the mismatch in bias currents results in a mismatch of voltage drops across the filter resistors. This mismatch creates a differential error voltage that subtracts from the voltage developed across the Kelvin connection of the shunt resistor, thus reducing the voltage that reaches the amplifier input terminals. Without the additional series resistance, the mismatch in input bias currents has little effect on device operation as a result of the low input bias current of the amplifier and the typically low impedance of the traces between the shunt and amplifier input pins. The amount of error these external filter resistors add to the measurement can be calculated using [Equation 3](#), where the gain error factor is calculated using [Equation 2](#).

The amount of variance between the differential voltage present at the device input relative to the voltage developed at the shunt resistor is based both on the external series resistance value as well as the internal input resistors, R_{INT} ; see [Figure 33](#). The reduction of the shunt voltage reaching the device input pins appears as a gain error when comparing the output voltage relative to the voltage across the shunt resistor. A factor can be calculated to determine the amount of gain error that is introduced by the addition of external series resistance. [Equation 2](#) calculates the expected deviation from the shunt voltage compared to the expected voltage at the device input pins.

$$\text{Gain Error Factor} = \frac{(1250 \times R_{INT})}{(1250 \times R_S) + (1250 \times R_{INT}) + (R_S \times R_{INT})}$$

where:

- R_{INT} is the internal input resistor and
 - R_S is the external series resistance
- (2)

$$\text{Gain Error (\%)} = 100 - (100 \times \text{Gain Error Factor})$$
(3)

With the adjustment factor equation including the device internal input resistance, this factor varies with each gain version; see [Table 1](#). Each individual device gain error factor is listed in [Table 2](#).

The gain error that can be expected from the addition of the external series resistors can then be calculated based on [Equation 3](#).

Device Functional Modes (continued)

Table 1. Input Resistance

DEVICE	GAIN	R _{INT}
INA250A1	200 mV/A	50 kΩ
INA250A2	500 mV/A	20 kΩ
INA250A3	800 mV/A	12.5 kΩ
INA250A4	2 V/A	5 kΩ

Table 2. Device Gain Error Factor

DEVICE	SIMPLIFIED GAIN ERROR FACTOR
INA250A1	$\frac{50,000}{(41 \cdot R_S) + 50,000}$
INA250A2	$\frac{20,000}{(17 \cdot R_S) + 20,000}$
INA250A3	$\frac{12,500}{(11 \cdot R_S) + 12,500}$
INA250A4	$\frac{1,000}{R_S + 1,000}$

For example, using an INA250A2 and the corresponding gain error equation from Table 2, a series resistance of 10 Ω results in a gain error factor of 0.991. The corresponding gain error is then calculated using Equation 3, resulting in a gain error of approximately 0.84% because of the external 10-Ω series resistors.

7.4.3 Shutting Down the Device

Although the device does not have a shutdown pin, the low power consumption allows for the device to be powered from the output of a logic gate or transistor switch that can turn on and turn off the voltage connected to the device power-supply pin. However, in current-shunt monitoring applications, there is also a concern for how much current is drained from the shunt circuit in shutdown conditions. Evaluating this current drain involves considering the device simplified schematic in shutdown mode, as shown in Figure 35.

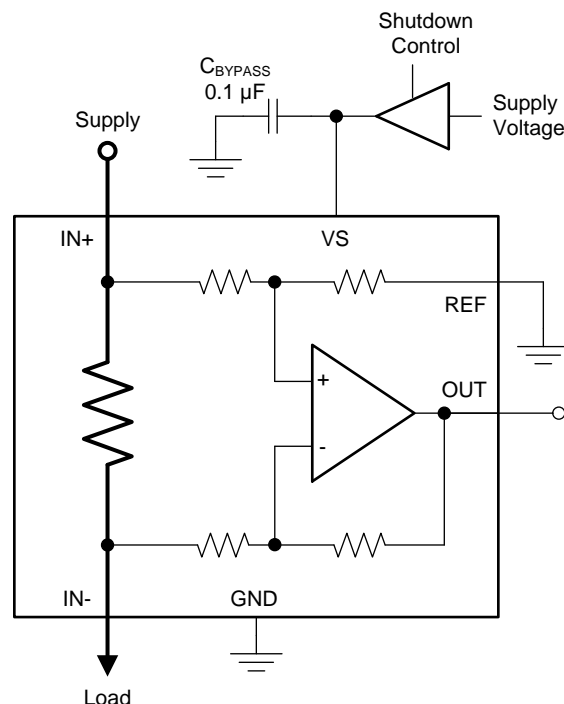

Figure 35. Shutting Down the Device

Note that there is typically an approximate 1-M Ω impedance (from the combination of the feedback and input resistors) from each device input to the REF pin. The amount of current flowing through these pins depends on the respective configuration. For example, if the REF pin is grounded, calculating the effect of the 1-M Ω impedance from the shunt to ground is straightforward. However, if the reference or op amp is powered when the device is shut down, the calculation is direct. Instead of assuming 1 M Ω to ground, assume 1 M Ω to the reference voltage. If the reference or op amp is also shut down, some knowledge of the reference or op amp output impedance under shutdown conditions is required. For instance, if the reference source functions similar to an open circuit when un-powered, little or no current flows through the 1-M Ω path.

7.4.4 Using the Device with Common-Mode Transients Above 36 V

With a small amount of additional circuitry, the device can be used in circuits subject to transients higher than 36 V (such as in automotive applications). Use only zener diodes or zener-type transient absorbers (sometimes referred to as *transzorbs*); any other type of transient absorber has an unacceptable time delay. Start by adding a pair of resistors, as shown in Figure 36, as a working impedance for the zener. Keeping these resistors as small as possible is preferable, most often approximately 10 Ω . This value limits the affect on accuracy with the addition of these external components, as described in the *Input Filtering* section. Device interconnections between the shunt resistor and amplifier have a current handling limit of 1 A. Using a 10- Ω resistor limits the allowable transient range to 10 V above the zener clamp in order to not damage the device. Larger resistor values can be used in this protection circuit to accommodate a larger transient voltage range, resulting in a larger affect on gain error. Because this circuit limits only short-term transients, many applications are satisfied with a 10- Ω resistor along with conventional zener diodes of the lowest power rating available.

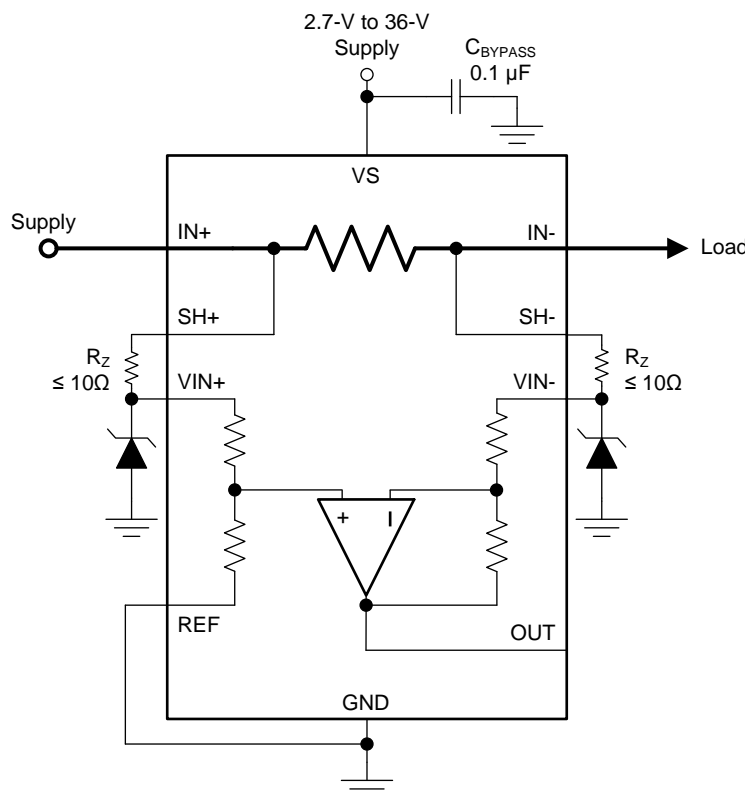

Figure 36. Device Transient Protection

8 Applications and Implementation

NOTE

Information in the following applications sections is not part of the TI component specification, and TI does not warrant its accuracy or completeness. TI's customers are responsible for determining suitability of components for their purposes. Customers should validate and test their design implementation to confirm system functionality.

8.1 Application Information

The INA250 measures the voltage developed across the internal current-sensing resistor when current passes through it. The ability to drive the reference pin to adjust the functionality of the output signal offers multiple configurations, as discussed in this section.

8.2 Typical Applications

8.2.1 Current Summing

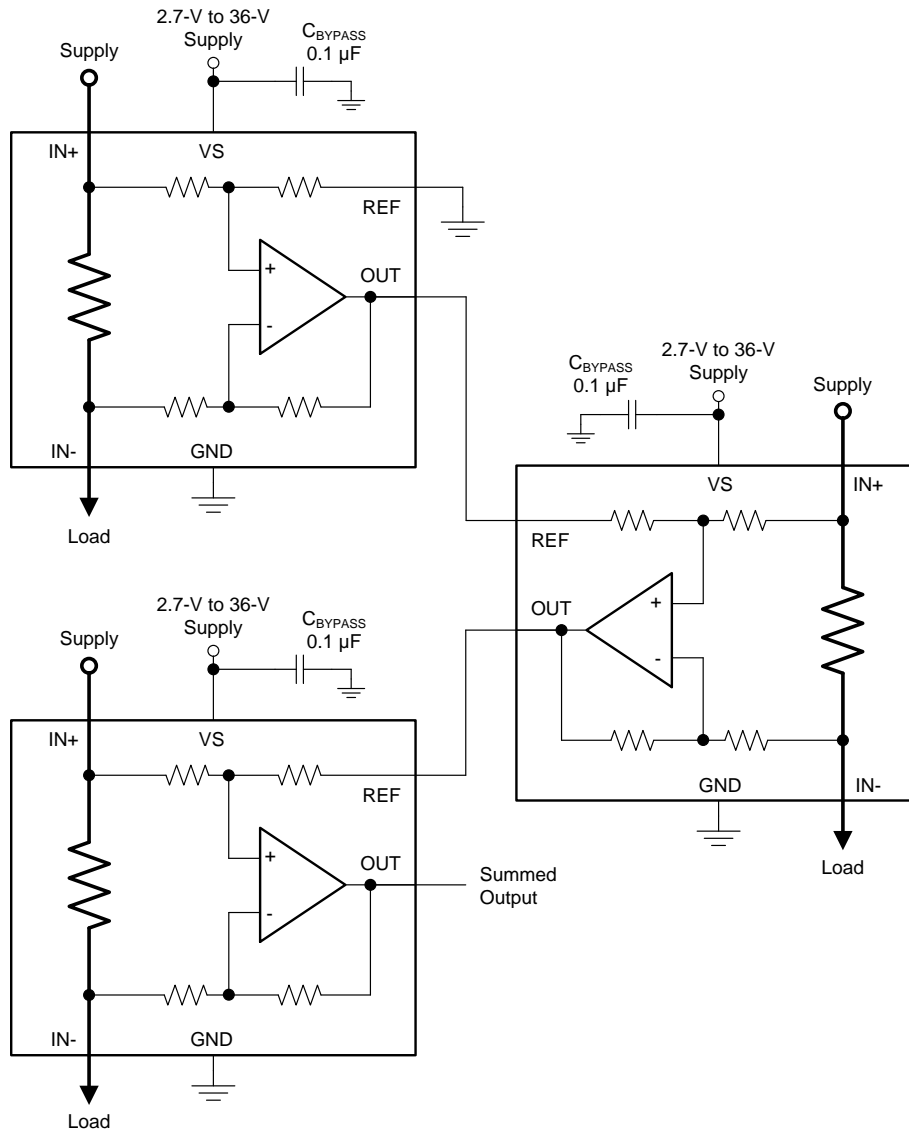

Figure 37. Daisy-Chain Configuration

Typical Applications (continued)

8.2.1.1 Design Requirements

Three daisy-chained devices are illustrated in [Figure 37](#). The reference input of the first INA250 sets the quiescent level on the output of all the INA250 devices in the string.

8.2.1.2 Detailed Design Procedure

The outputs of multiple INA250 devices are easily summed by connecting the output signal of one INA250 to the reference input of a second INA250. Summing beyond two devices is possible by repeating this configuration, connecting the output signal of the next INA250 to the reference pin of a subsequent INA250 in the chain. The output signal of the final INA250 in this chain includes the current level information for all channels in the chain.

8.2.1.3 Application Curve

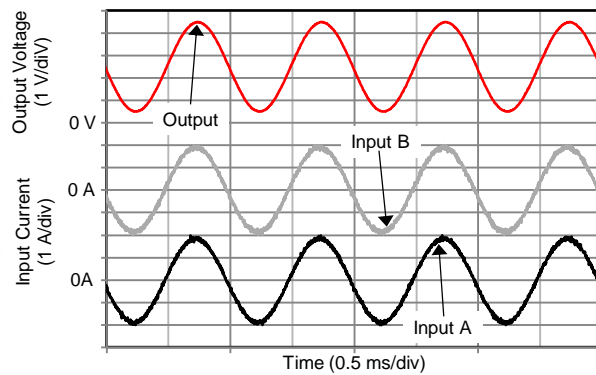

$$V_S = 5 \text{ V}, V_{REF} = 2.5 \text{ V}$$

Figure 38. Daisy-Chain Configuration Output Response

Typical Applications (continued)

8.2.2 Parallel Multiple INA250 Devices for Higher Current

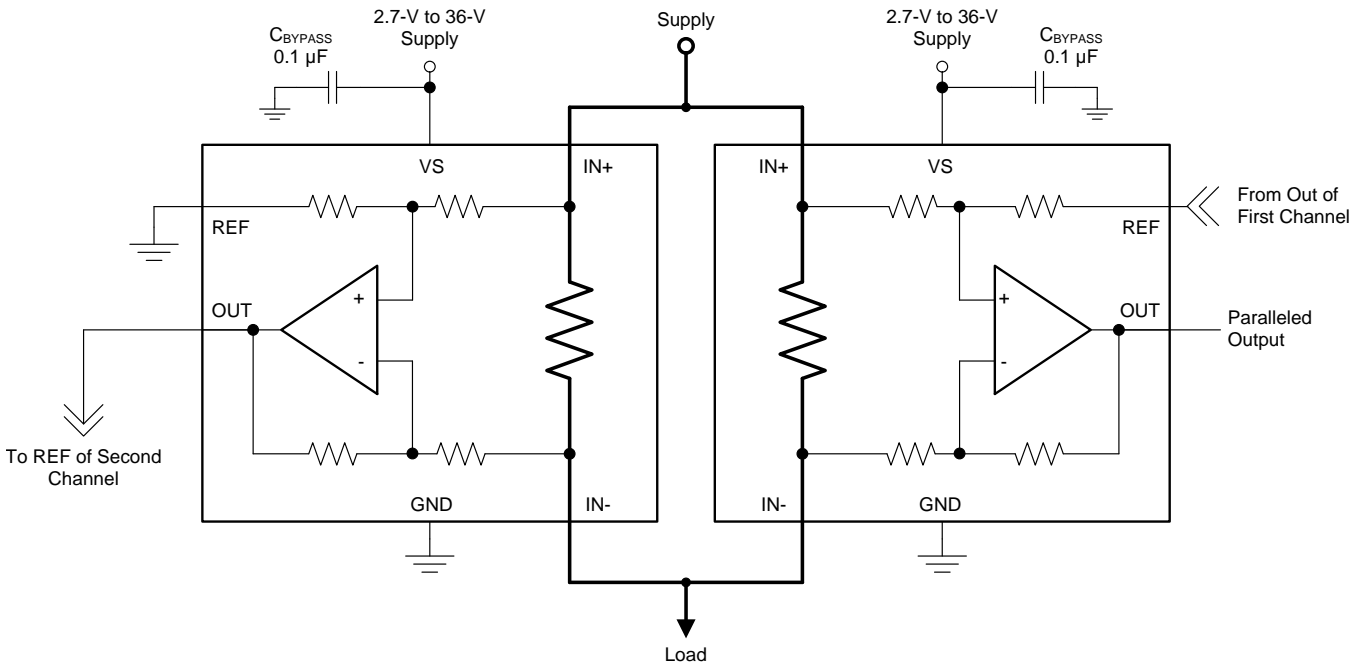

Figure 39. Parallel Summing Configuration

8.2.2.1 Design Requirements

The parallel connection for multiple INA250 devices can be used to reduce the equivalent overall sense resistance, enabling monitoring of higher current levels than a single device is able to accommodate alone. This configuration also uses a summing arrangement, as described in the [Current Summing](#) section. A parallel summing configuration is shown in [Figure 39](#).

8.2.2.2 Detailed Design Procedure

With a summing configuration the output of the first channel is fed into the reference input of the second, adding the distributed measurements back together into a single measured value.

8.2.2.3 Application Curve

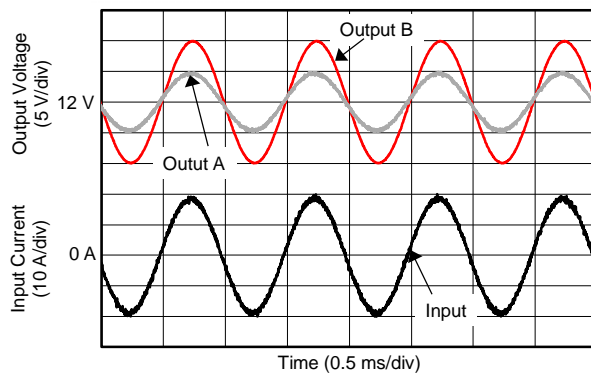

$V_S = 24\text{ V}, V_{REF} = 12\text{ V}$

Figure 40. Parallel Configuration Output Response

Typical Applications (continued)

8.2.3 Current Differencing

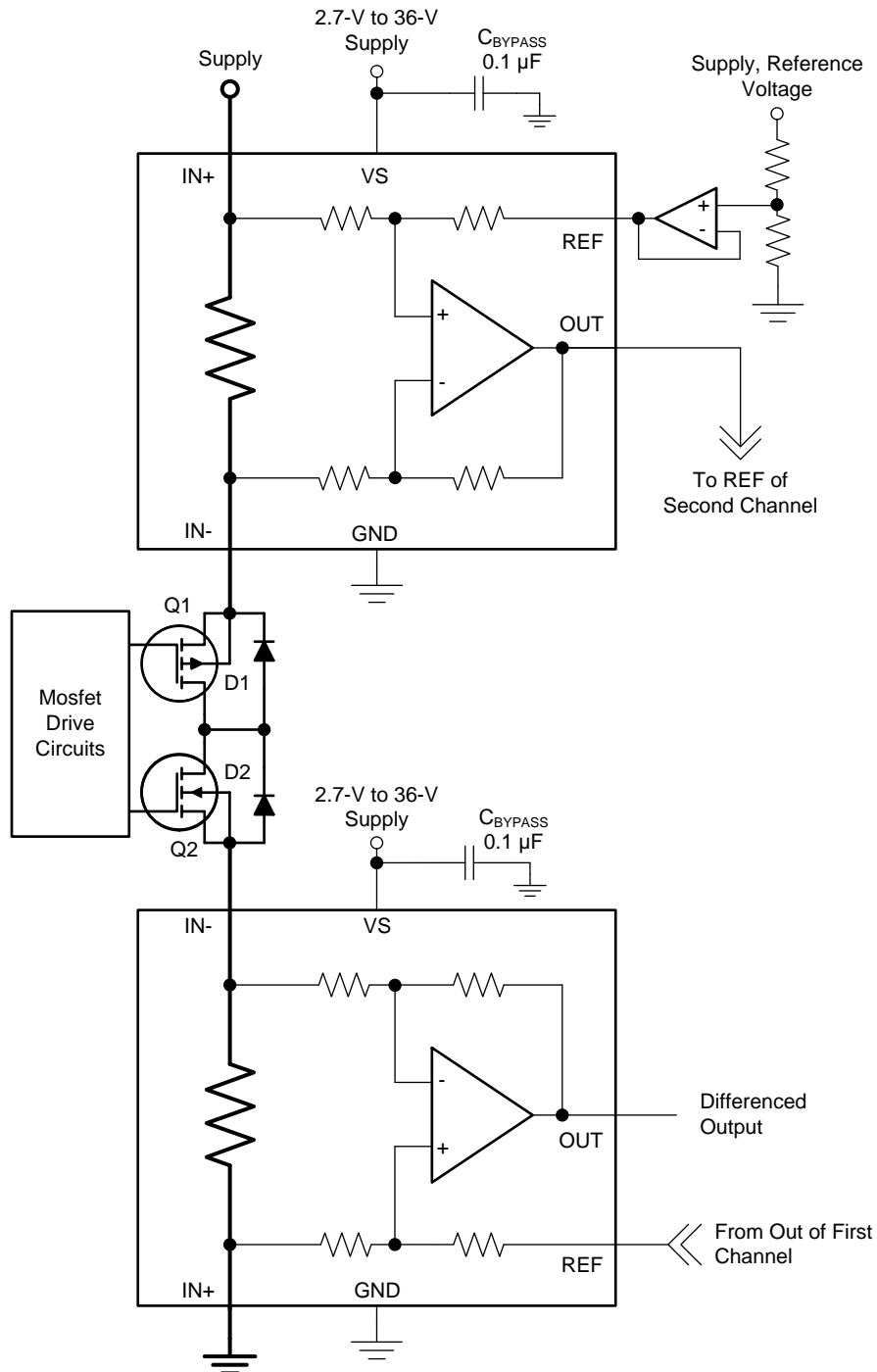

Figure 41. Current Differencing Configuration

Typical Applications (continued)

8.2.3.1 Design Requirements

Occasionally, the need may arise to confirm that the current into a load is identical to the current coming out of a load, such as when performing diagnostic testing or fault detection. This procedure requires precision current differencing. This method is the same as current summing, except that the two amplifiers have the respective inputs connected opposite of each other. Under normal operating conditions, the final output is very close to the reference value and proportional to any current difference. Figure 41 is an example of two INA250 devices connected for current differencing.

8.2.3.2 Detailed Design Procedure

The load current can also be measured directly at the output of the first channel. Although technically this configuration is current differencing, this connection (see Figure 41) is really intended to allow the upper (positive) sense channel to report any positive-going excursions in the overall output and the lower (negative) sense channel to report any negative-going excursions.

8.2.3.3 Application Curve

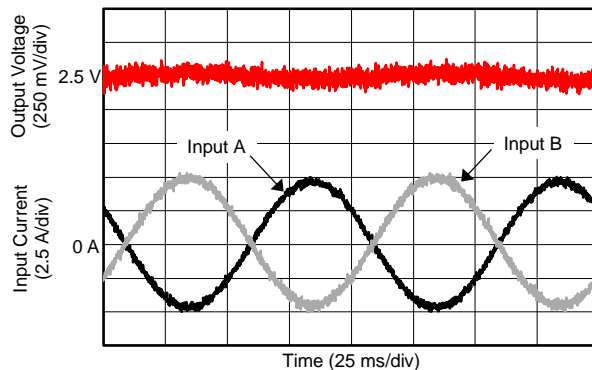

$$V_S = 5 \text{ V}, V_{REF} = 2.5 \text{ V}$$

Figure 42. Current Differencing Configuration Output Response

9 Power Supply Recommendations

The input circuitry of the device can accurately measure signals on common-mode voltages beyond the power-supply voltage, V_S . For example, the voltage applied to the V_S power-supply pin can be 5 V, whereas the load power-supply voltage being monitored (the common-mode voltage) can be as high as 36 V. Note also that the device can withstand the full 0-V to 36-V range at the input pins, regardless of whether the device has power applied or not. Power-supply bypass capacitors are required for stability and must be placed as closely as possible to the supply and ground pins of the device. A typical value for this supply bypass capacitor is 0.1 μF . Applications with noisy or high-impedance power supplies can require additional decoupling capacitors to reject power-supply noise.

10 Layout

10.1 Layout Guidelines

- The INA250 is specified for current handling of up to 10 A over the entire -40°C to 125°C temperature range using a 1-oz. copper pour for the input power plane as well as no external airflow passing over the device.
- The primary current-handling limitation for the INA250 is how much heat is dissipated inside the package. Efforts to improve heat transfer out of the package and into the surrounding environment improve the ability of the device to handle currents of up to 15 A over the entire -40°C to 125°C temperature range.
- Heat transfer improvements primarily involve larger copper power traces and planes with increased copper thickness (2 oz.) as well as providing airflow to pass over the device. The [INA250EVM](#) features a 2-oz. copper pour for the planes and is capable of supporting 15 A at temperatures up to 125°C .
- Place the power-supply bypass capacitor as close as possible to the supply and ground pins. The recommended value of this bypass capacitor is $0.1\ \mu\text{F}$. Additional decoupling capacitance can be added to compensate for noisy or high-impedance power supplies.

10.2 Layout Examples

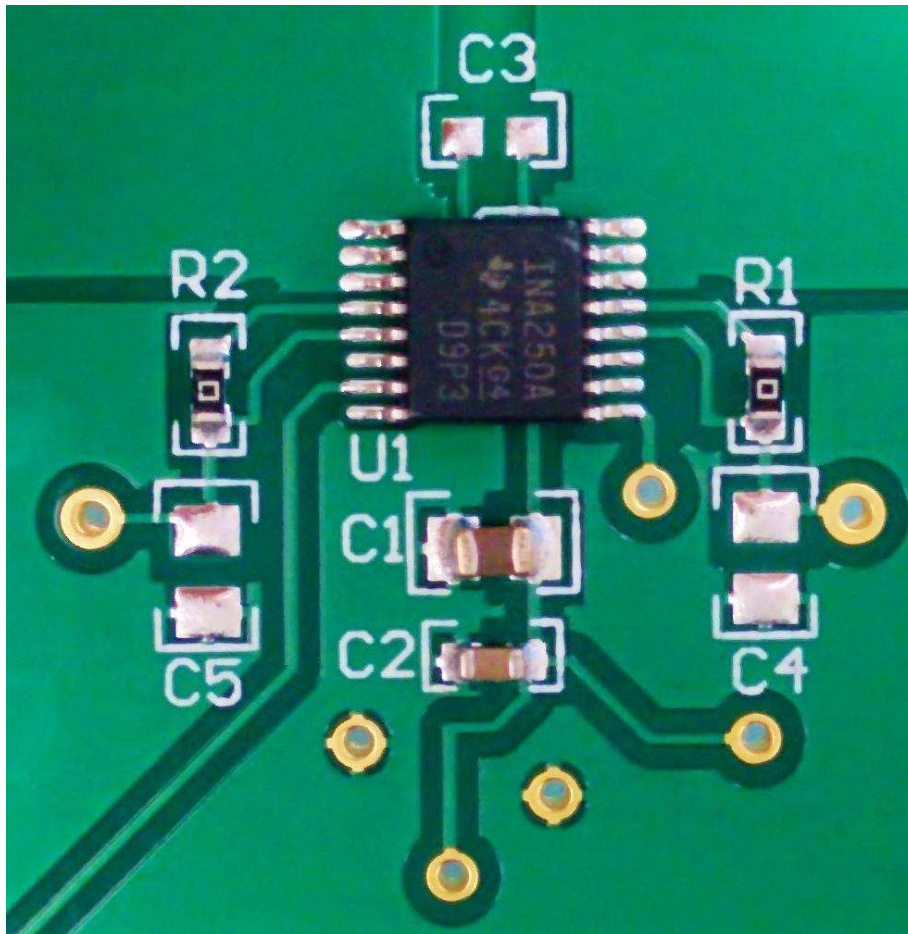

Figure 43. Recommended Layout

Layout Examples (continued)

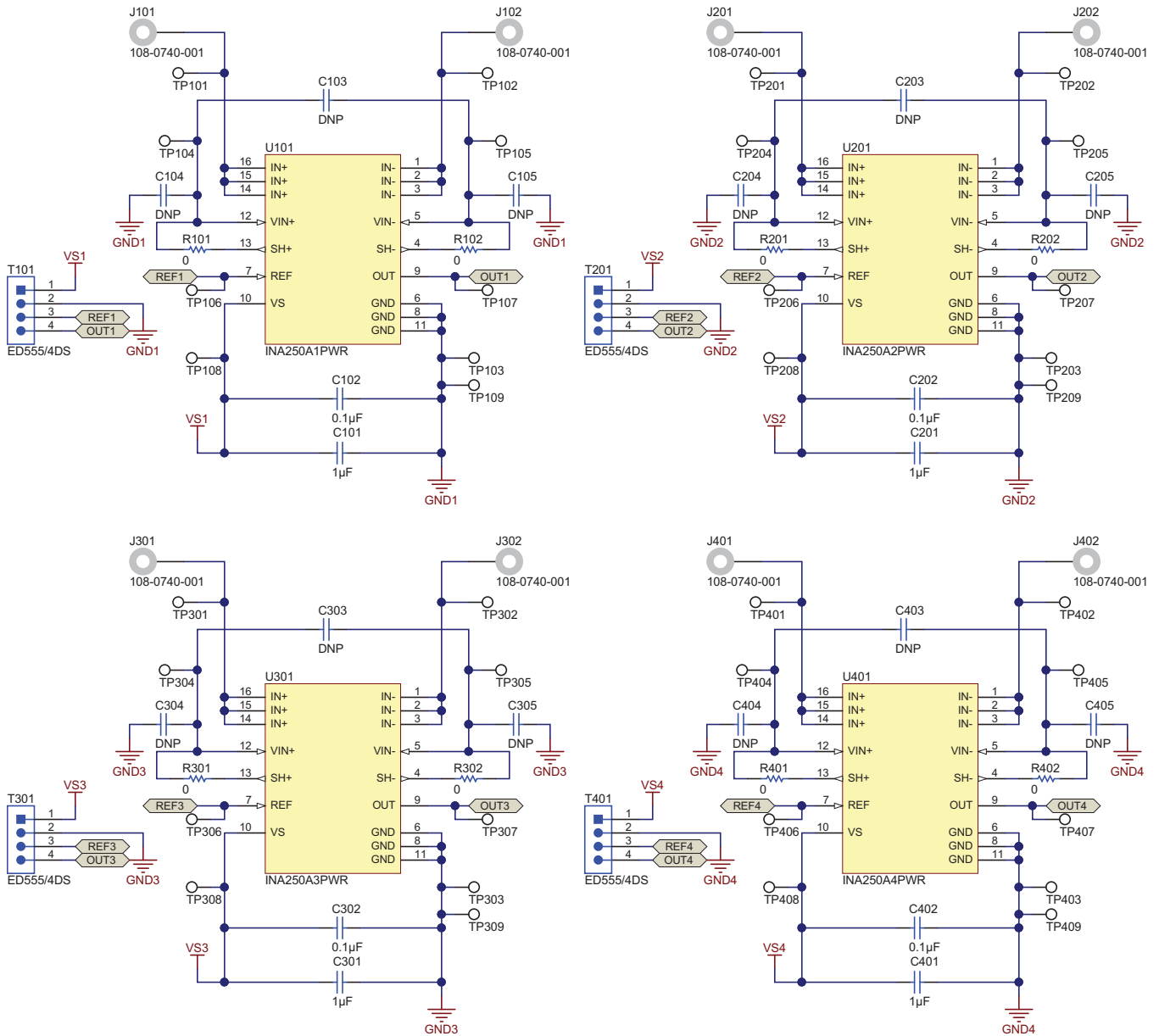

Figure 44. Recommended Layout Schematic

11 器件和文档支持

11.1 文档支持

11.1.1 相关文档

- 《INA250EVM 用户指南》，[SBOU153](#)

11.2 相关链接

下面的表格列出了快速访问链接。范围包括技术文档、支持与社区资源、工具和软件，以及样片或购买的快速访问。

表 3. 相关链接

器件	产品文件夹	样片与购买	技术文档	工具与软件	支持与社区
INA250A1	请单击此处	请单击此处	请单击此处	请单击此处	请单击此处
INA250A2	请单击此处	请单击此处	请单击此处	请单击此处	请单击此处
INA250A3	请单击此处	请单击此处	请单击此处	请单击此处	请单击此处
INA250A4	请单击此处	请单击此处	请单击此处	请单击此处	请单击此处

11.3 社区资源

The following links connect to TI community resources. Linked contents are provided "AS IS" by the respective contributors. They do not constitute TI specifications and do not necessarily reflect TI's views; see TI's [Terms of Use](#).

TI E2E™ Online Community *TI's Engineer-to-Engineer (E2E) Community*. Created to foster collaboration among engineers. At e2e.ti.com, you can ask questions, share knowledge, explore ideas and help solve problems with fellow engineers.

Design Support *TI's Design Support* Quickly find helpful E2E forums along with design support tools and contact information for technical support.

11.4 商标

E2E is a trademark of Texas Instruments.
All other trademarks are the property of their respective owners.

11.5 静电放电警告



ESD 可能会损坏该集成电路。德州仪器 (TI) 建议通过适当的预防措施处理所有集成电路。如果不遵守正确的处理措施和安装程序，可能会损坏集成电路。

ESD 的损坏小至导致微小的性能降级，大至整个器件故障。精密的集成电路可能更容易受到损坏，这是因为非常细微的参数更改都可能会导致器件与其发布的规格不相符。

11.6 Glossary

[SLYZ022](#) — *TI Glossary*.

This glossary lists and explains terms, acronyms, and definitions.

12 机械、封装和可订购信息

以下页中包括机械、封装和可订购信息。这些信息是针对指定器件可提供的最新数据。这些数据会在无通知且不对本文档进行修订的情况下发生改变。欲获得该数据表的浏览器版本，请查阅左侧的导航栏。

PACKAGING INFORMATION

Orderable Device	Status (1)	Package Type	Package Drawing	Pins	Package Qty	Eco Plan (2)	Lead finish/ Ball material (6)	MSL Peak Temp (3)	Op Temp (°C)	Device Marking (4/5)	Samples
INA250A1PW	ACTIVE	TSSOP	PW	16	90	RoHS & Green	NIPDAU	Level-2-260C-1 YEAR	-40 to 125	I250A1	Samples
INA250A1PWR	ACTIVE	TSSOP	PW	16	2000	RoHS & Green	NIPDAU	Level-2-260C-1 YEAR	-40 to 125	I250A1	Samples
INA250A2PW	ACTIVE	TSSOP	PW	16	90	RoHS & Green	NIPDAU	Level-2-260C-1 YEAR	-40 to 125	I250A2	Samples
INA250A2PWR	ACTIVE	TSSOP	PW	16	2000	RoHS & Green	NIPDAU	Level-2-260C-1 YEAR	-40 to 125	I250A2	Samples
INA250A3PW	ACTIVE	TSSOP	PW	16	90	RoHS & Green	NIPDAU	Level-2-260C-1 YEAR	-40 to 125	I250A3	Samples
INA250A3PWR	ACTIVE	TSSOP	PW	16	2000	RoHS & Green	NIPDAU	Level-2-260C-1 YEAR	-40 to 125	I250A3	Samples
INA250A4PW	ACTIVE	TSSOP	PW	16	90	RoHS & Green	NIPDAU	Level-2-260C-1 YEAR	-40 to 125	I250A4	Samples
INA250A4PWR	ACTIVE	TSSOP	PW	16	2000	RoHS & Green	NIPDAU	Level-2-260C-1 YEAR	-40 to 125	I250A4	Samples

(1) The marketing status values are defined as follows:

ACTIVE: Product device recommended for new designs.

LIFEBUY: TI has announced that the device will be discontinued, and a lifetime-buy period is in effect.

NRND: Not recommended for new designs. Device is in production to support existing customers, but TI does not recommend using this part in a new design.

PREVIEW: Device has been announced but is not in production. Samples may or may not be available.

OBSOLETE: TI has discontinued the production of the device.

(2) **RoHS:** TI defines "RoHS" to mean semiconductor products that are compliant with the current EU RoHS requirements for all 10 RoHS substances, including the requirement that RoHS substance do not exceed 0.1% by weight in homogeneous materials. Where designed to be soldered at high temperatures, "RoHS" products are suitable for use in specified lead-free processes. TI may reference these types of products as "Pb-Free".

RoHS Exempt: TI defines "RoHS Exempt" to mean products that contain lead but are compliant with EU RoHS pursuant to a specific EU RoHS exemption.

Green: TI defines "Green" to mean the content of Chlorine (Cl) and Bromine (Br) based flame retardants meet JS709B low halogen requirements of <=1000ppm threshold. Antimony trioxide based flame retardants must also meet the <=1000ppm threshold requirement.

(3) MSL, Peak Temp. - The Moisture Sensitivity Level rating according to the JEDEC industry standard classifications, and peak solder temperature.

(4) There may be additional marking, which relates to the logo, the lot trace code information, or the environmental category on the device.

(5) Multiple Device Markings will be inside parentheses. Only one Device Marking contained in parentheses and separated by a "~" will appear on a device. If a line is indented then it is a continuation of the previous line and the two combined represent the entire Device Marking for that device.

⁽⁶⁾ Lead finish/Ball material - Orderable Devices may have multiple material finish options. Finish options are separated by a vertical ruled line. Lead finish/Ball material values may wrap to two lines if the finish value exceeds the maximum column width.

Important Information and Disclaimer: The information provided on this page represents TI's knowledge and belief as of the date that it is provided. TI bases its knowledge and belief on information provided by third parties, and makes no representation or warranty as to the accuracy of such information. Efforts are underway to better integrate information from third parties. TI has taken and continues to take reasonable steps to provide representative and accurate information but may not have conducted destructive testing or chemical analysis on incoming materials and chemicals. TI and TI suppliers consider certain information to be proprietary, and thus CAS numbers and other limited information may not be available for release.

In no event shall TI's liability arising out of such information exceed the total purchase price of the TI part(s) at issue in this document sold by TI to Customer on an annual basis.

TAPE AND REEL INFORMATION

QUADRANT ASSIGNMENTS FOR PIN 1 ORIENTATION IN TAPE



*All dimensions are nominal

Device	Package Type	Package Drawing	Pins	SPQ	Reel Diameter (mm)	Reel Width W1 (mm)	A0 (mm)	B0 (mm)	K0 (mm)	P1 (mm)	W (mm)	Pin1 Quadrant
INA250A1PWR	TSSOP	PW	16	2000	330.0	12.4	6.9	5.6	1.6	8.0	12.0	Q1
INA250A2PWR	TSSOP	PW	16	2000	330.0	12.4	6.9	5.6	1.6	8.0	12.0	Q1
INA250A3PWR	TSSOP	PW	16	2000	330.0	12.4	6.9	5.6	1.6	8.0	12.0	Q1
INA250A4PWR	TSSOP	PW	16	2000	330.0	12.4	6.9	5.6	1.6	8.0	12.0	Q1

TAPE AND REEL BOX DIMENSIONS

*All dimensions are nominal

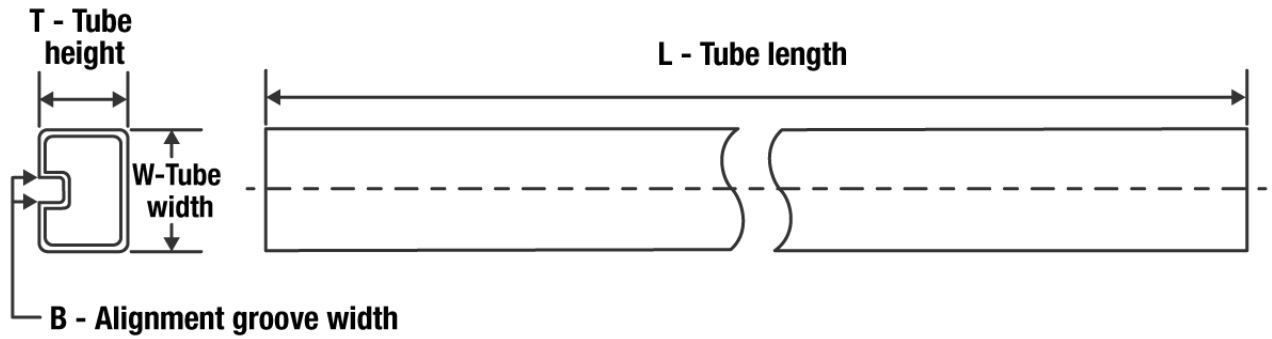
Device	Package Type	Package Drawing	Pins	SPQ	Length (mm)	Width (mm)	Height (mm)
INA250A1PWR	TSSOP	PW	16	2000	853.0	449.0	35.0
INA250A2PWR	TSSOP	PW	16	2000	853.0	449.0	35.0
INA250A3PWR	TSSOP	PW	16	2000	853.0	449.0	35.0
INA250A4PWR	TSSOP	PW	16	2000	853.0	449.0	35.0

TUBE

*All dimensions are nominal

Device	Package Name	Package Type	Pins	SPQ	L (mm)	W (mm)	T (μm)	B (mm)
INA250A1PW	PW	TSSOP	16	90	530	10.2	3600	3.5
INA250A2PW	PW	TSSOP	16	90	530	10.2	3600	3.5
INA250A3PW	PW	TSSOP	16	90	530	10.2	3600	3.5
INA250A4PW	PW	TSSOP	16	90	530	10.2	3600	3.5



4220204/A 02/2017

NOTES:

1. All linear dimensions are in millimeters. Any dimensions in parenthesis are for reference only. Dimensioning and tolerancing per ASME Y14.5M.
2. This drawing is subject to change without notice.
3. This dimension does not include mold flash, protrusions, or gate burrs. Mold flash, protrusions, or gate burrs shall not exceed 0.15 mm per side.
4. This dimension does not include interlead flash. Interlead flash shall not exceed 0.25 mm per side.
5. Reference JEDEC registration MO-153.

EXAMPLE BOARD LAYOUT

PW0016A

TSSOP - 1.2 mm max height

SMALL OUTLINE PACKAGE



LAND PATTERN EXAMPLE
EXPOSED METAL SHOWN
SCALE: 10X



4220204/A 02/2017

NOTES: (continued)

- 6. Publication IPC-7351 may have alternate designs.
- 7. Solder mask tolerances between and around signal pads can vary based on board fabrication site.

EXAMPLE STENCIL DESIGN

PW0016A

TSSOP - 1.2 mm max height

SMALL OUTLINE PACKAGE



SOLDER PASTE EXAMPLE
BASED ON 0.125 mm THICK STENCIL
SCALE: 10X

4220204/A 02/2017

NOTES: (continued)

8. Laser cutting apertures with trapezoidal walls and rounded corners may offer better paste release. IPC-7525 may have alternate design recommendations.
9. Board assembly site may have different recommendations for stencil design.

重要声明和免责声明

TI“按原样”提供技术和可靠性数据（包括数据表）、设计资源（包括参考设计）、应用或其他设计建议、网络工具、安全信息和其他资源，不保证没有瑕疵且不做任何明示或暗示的担保，包括但不限于对适销性、某特定用途方面的适用性或不侵犯任何第三方知识产权的暗示担保。

这些资源可供使用 TI 产品进行设计的熟练开发人员使用。您将自行承担以下全部责任：(1) 针对您的应用选择合适的 TI 产品，(2) 设计、验证并测试您的应用，(3) 确保您的应用满足相应标准以及任何其他功能安全、信息安全、监管或其他要求。

这些资源如有变更，恕不另行通知。TI 授权您仅可将这些资源用于研发本资源所述的 TI 产品的应用。严禁对这些资源进行其他复制或展示。您无权使用任何其他 TI 知识产权或任何第三方知识产权。您应全额赔偿因在这些资源的使用中对 TI 及其代表造成的任何索赔、损害、成本、损失和债务，TI 对此概不负责。

TI 提供的产品受 [TI 的销售条款](#) 或 [ti.com](#) 上其他适用条款/TI 产品随附的其他适用条款的约束。TI 提供这些资源并不会扩展或以其他方式更改 TI 针对 TI 产品发布的适用的担保或担保免责声明。

TI 反对并拒绝您可能提出的任何其他或不同的条款。

邮寄地址：Texas Instruments, Post Office Box 655303, Dallas, Texas 75265

Copyright © 2022，德州仪器 (TI) 公司