

TPS22933 具有自动选择功能和低压降稳压器的三路输入电源多路复用器

1 特性

- 三个集成负载开关，自动选择最高电平输入
- 集成 3.6V 固定电压低压降 (LDO) 稳压器
- 提供开关控制式和始终开启式两种 LDO 输出
- 采用 1.5mm × 1.5mm μ QFN 封装
- 输入电压范围：2.5V 至 12V
- 低导通电阻 (r_{ON})
 - $V_{IN} = 5.0V$ 时， $r_{ON} = 2.4\Omega$
 - $V_{IN} = 4.2V$ 时， $r_{ON} = 2.6\Omega$
- 50mA 的最大持续电流
- 低阈值控制输入 (EN)
- 切换时间：18 μ s (典型值)

2 应用范围

- 智能电话
- 全球卫星定位 (GPS) 设备
- 数码摄像机
- 便携式工业设备
- 便携式医疗设备
- 便携式媒体播放器
- 便携式仪表

3 说明

TPS22933 器件是一款具有自动输入选择功能和低压降线性稳压器的三路输入电源多路复用器，同时兼具小尺寸和低 r_{ON} 特性。此器件包含三个 P 沟道金属氧化物半导体场效应晶体管 (MOSFET)，它们的工作输入电压范围为 2.5V 到 12V。TPS22933 能够自动选择电平最高的输入 (从 BAT、USB 和 DC_IN 三者中选择) 并将其提供给 LDO。LOUT 是 LDO 始终开启的输出。通过使能功能 (EN 引脚)，可以对 VOUT 进行开关控制，接通快速放电电阻，而且能够直接连接低电压控制信号。

TPS22933 采用小型、节省空间的 8 引脚 μ QFN 封装，并可在 -40°C 至 85°C 温度范围内的自然通风条件下额定运行。

器件信息(1)

器件型号	封装	封装尺寸 (标称值)
TPS22933	UQFN (8)	1.50mm x 1.50mm

(1) 要了解所有可用封装，请见数据表末尾的可订购产品附录。

典型应用图

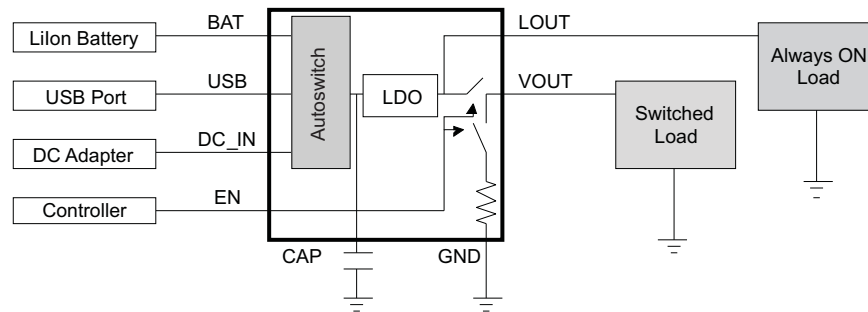

目录

1	特性	1	8.3	Feature Description.....	11
2	应用范围.....	1	8.4	Device Functional Modes.....	12
3	说明.....	1	9	Application and Implementation	13
4	修订历史记录	2	9.1	Application Information.....	13
5	Pin Configuration and Functions	3	9.2	Typical Application	13
6	Specifications.....	3	10	Power Supply Recommendations	15
6.1	Absolute Maximum Ratings	3	11	Layout.....	15
6.2	ESD Ratings.....	4	11.1	Layout Guidelines	15
6.3	Recommended Operating Conditions.....	4	11.2	Layout Example	16
6.4	Thermal Information	4	12	器件和文档支持	17
6.5	Electrical Characteristics.....	5	12.1	社区资源.....	17
6.6	Typical Characteristics.....	6	12.2	商标.....	17
7	Parametric Measurement Information	10	12.3	静电放电警告.....	17
8	Detailed Description	11	12.4	Glossary	17
8.1	Overview	11	13	机械、封装和可订购信息.....	17
8.2	Functional Block Diagram	11			

4 修订历史记录

注：之前版本的页码可能与当前版本有所不同。

Changes from Original (October 2011) to Revision A

Page

- 已添加 引脚配置和功能部分，ESD 额定值表，特性说明部分，器件功能模式，应用和实施部分，电源相关建议部分，布局部分，器件和文档支持部分以及机械、封装和可订购信息部分

1

S

5 Pin Configuration and Functions

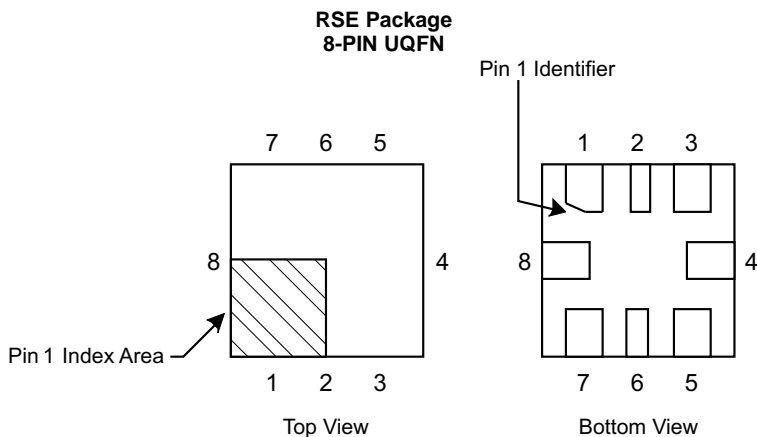

Pin Functions

PIN		I/O	DESCRIPTION
NO.	NAME		
1	BAT	I	Source Voltage 1 (Battery)
2	USB	I	Source Voltage 2 (V+ USB)
3	DC_IN	I	Source Voltage 3 (DC Adapter)
4	GND	—	Ground
5	EN	I	VOUT Enable (Cannot be left floating)
6	CAP	O	Capacitor for LDO
7	VOUT	O	Switched LDO Output
8	LOUT	O	Always on LDO Output

6 Specifications

6.1 Absolute Maximum Ratings

over operating free-air temperature range (unless otherwise noted)⁽¹⁾

			MIN	MAX	UNIT
V _{IN}	Input voltage	BAT, USB, DC_IN	−0.3	14	V
V _{OUTPUT}	Output voltage	VOUT, LOUT	−0.3	6	V
V _{EN}	Input voltage	EN	−0.3	6	V
I _{MAX}	Maximum continuous switch current			75	mA
I _{PULSE}	Maximum pulsed switch current, pulse <300 μs, 2% duty cycle			100	mA
T _A	Operating free-air temperature		−40	85	°C
T _{lead}	Maximum lead temperature (10-s soldering time)			300	°C
T _{stg}	Storage temperature		−65	150	°C

- (1) Stresses beyond those listed under *Absolute Maximum Ratings* may cause permanent damage to the device. These are stress ratings only, which do not imply functional operation of the device at these or any other conditions beyond those indicated under *Recommended Operating Conditions*. Exposure to absolute-maximum-rated conditions for extended periods may affect device reliability.

6.2 ESD Ratings

		VALUE	UNIT
$V_{(ESD)}$ Electrostatic discharge	Human-body model (HBM), per ANSI/ESDA/JEDEC JS-001 ⁽¹⁾	±2000	V
	Charged-device model (CDM), per JEDEC specification JESD22-C101 ⁽²⁾	±1000	

- (1) JEDEC document JEP155 states that 500-V HBM allows safe manufacturing with a standard ESD control process. Manufacturing with less than 500-V HBM is possible with the necessary precautions. Pins listed as ±2000 V may actually have higher performance.
- (2) JEDEC document JEP157 states that 250-V CDM allows safe manufacturing with a standard ESD control process. Manufacturing with less than 250-V CDM is possible with the necessary precautions. Pins listed as ±1000 V may actually have higher performance.

6.3 Recommended Operating Conditions

			MIN	NOM	MAX	UNIT
V_{IN}	Input voltage	BAT, USB, DC_IN	2.5		12	V
V_{EN}		EN	0		5.5	V
V_{IH}	EN pin High-level input voltage, (EN > V_{IH} Min, VOUT = LDO Output)	BAT = 2.5 V to 5.5 V, USB, DC_IN = 2.5 V to 12 V	1.15		5.5	V
V_{IL}	EN pin Low-level input voltage, (EN < V_{IL} Max, VOUT = pulldown)	BAT = 2.5 V to 5.5 V, USB, DC_IN = 2.5 V to 12 V	0		0.6	V
$I_{OUT-LOUT}$	LOUT Current	$V_{BAT} = 4.2$ V OR $V_{USB} = 5$ V OR $V_{DC_IN} = 5$ V, EN = 3.4 V, $I_{OUT-VOUT} = 0$ mA			50	mA
$I_{OUT-VOUT}$	VOUT Current	$V_{BAT} = 4.2$ V OR $V_{USB} = 5$ V OR $V_{DC_IN} = 5$ V, EN = 3.4 V, $I_{OUT-LOUT} = 0$ mA			50	mA
$I_{OUT-TOTAL}$	LOUT + VOUT current	$V_{BAT} = 4.2$ V OR $V_{USB} = 5$ V OR $V_{DC_IN} = 5$ V, EN = 3.4 V			50	mA
CAP	LDO Capacitor (on CAP pin)		20 ⁽¹⁾			nF
	LOUT Capacitor				1	μF
	VOUT Capacitor				1	μF

- (1) Refer to [Application and Implementation](#).

6.4 Thermal Information

THERMAL METRIC ⁽¹⁾		TPS22933	UNIT
		RSE (UQFN)	
		6 PINS	
$R_{\theta JA}$	Junction-to-ambient thermal resistance	115.6	°C/W
$R_{\theta JC(top)}$	Junction-to-case (top) thermal resistance	59.9	°C/W
$R_{\theta JB}$	Junction-to-board thermal resistance	27.4	°C/W
ψ_{JT}	Junction-to-top characterization parameter	2.1	°C/W
ψ_{JB}	Junction-to-board characterization parameter	27.3	°C/W
$R_{\theta JC(bot)}$	Junction-to-case (bottom) thermal resistance	—	°C/W

- (1) For more information about traditional and new thermal metrics, see the *Semiconductor and IC Package Thermal Metrics* application report, [SPRA953](#).

6.5 Electrical Characteristics

BAT = 2.5 V to 12.0 V, USB = 2.5 V to 12.0 V, DC_IN = 2.5 V to 12.0 V, T_A = –40°C to +85°C (unless otherwise noted)

PARAMETER		TEST CONDITIONS ^{(1) (2) (3)}	T _A	MIN	TYP ⁽⁴⁾	MAX	UNIT
I _{IN-BAT}	Operating current	I _{OUT} = 0 mA, V _{BAT} = 4.2 V, V _{USB} = 3 V, V _{DC_IN} = 3 V, EN = 3.4 V	Full		9.2	15	μA
	Quiescent current	I _{OUT} = 0, V _{BAT} = 4.2 V, V _{USB} = 5 V, V _{DC_IN} = 3 V, EN = 3.4 V			0.7	2	
I _{IN-USB}	Operating current	I _{OUT} = 0 mA, V _{BAT} = 4.2 V, V _{USB} = 5 V, V _{DC_IN} = 3 V, EN = 3.4 V	Full		9.2	15	μA
	Quiescent current	I _{OUT} = 0, V _{BAT} = 4.2V, V _{USB} = 5V, V _{DC_IN} = 5.5V, EN = 3.4 V			0.7	2	
I _{IN-DC_IN}	Operating current	I _{OUT} = 0 mA, V _{BAT} = 4.2 V, V _{USB} = 3 V, V _{DC_IN} = 5 V, EN = 3.4 V	Full		9.2	15	μA
	Quiescent current	I _{OUT} = 0, V _{BAT} = 4.2V, V _{USB} = 5.5V, V _{DC_IN} = 5V, EN = 3.4 V			0.7	2	
I _{IN-USB}	Hi-Voltage operating current	I _{OUT} = 0 mA, V _{BAT} = 4.2 V, V _{USB} = 12 V, V _{DC_IN} = 5 V, EN = 3.4 V	Full		10.8	20	μA
I _{IN-DC_IN}	Hi-Voltage operating current	I _{OUT} = 0 mA, V _{BAT} = 4.2 V, V _{USB} = 5 V, V _{DC_IN} = 12 V, EN = 3.4 V	Full		10.8	20	μA
R _{ON}	ON resistance (USB to CAP, BAT to CAP, DC_IN to CAP)	V _{IN} = 5.0 V, I _{OUT} = 10 mA	25°C		2.4	3.3	Ω
			Full			3.5	
		V _{IN} = 4.2 V, I _{OUT} = 10 mA	25°C		2.6	3.5	Ω
			Full			4	
V _{IN} = 2.5 V, I _{OUT} = 10 mA	25°C		3.8	5	Ω		
	Full			6			
R _{ONVOUT}	ON resistance (LDO output to VOUT)	V _{IN} = 4.2 V, I _{OUT-VOUT} = 10 mA	25°C		1.3	2.5	Ω
			Full			3	
R _{PD}	Output pulldown resistance	V _{IN} = 4.2 V, V _{EN} = 0 V, I(into VOUT) = 10 mA	25°C		63.8	120	Ω
I _{EN}	EN input leakage	V _{EN} = 1.6 V to 5.5 V or GND	Full			1	μA
V _{DO-VOUT}	Dropout voltage VOUT ^{(5) (6)}	I _{OUT} = 10 mA	Full		0.11		V
V _{DO-LOUT}	Dropout voltage LOUT	I _{OUT} = 10 mA ^{(5) (6)}	Full		0.1		V
V _{LOUT}	Always on LDO output voltage (LOUT pin)	V _{IN} < 3.4 V, I _{OUT} = 10 mA, V _{EN} = 1.8 V	Full		V _{IN} – V _{DO-LOUT}		V
		V _{IN} > 4 V, I _{OUT} = 10 mA, V _{EN} = 1.8 V	Full	3.42	3.6	3.78	
V _{VOUT}	Switched LDO output voltage (VOUT pin)	V _{IN} < 3.4 V, I _{OUT} = 10 mA, V _{EN} = 1.8 V	Full		V _{IN} – V _{DO-VOUT}		V
		V _{IN} > 4 V, I _{OUT} = 10 mA, V _{EN} = 1.8 V	Full	3.39	3.57	3.75	
V _{CO}	Changeover voltage	V _{BAT} = 4.2 V, V _{USB} = 4.0 V rising to 4.4 V	Full		0.15		V
t _{CO}	Changeover time	V _{BAT} =4.2 V, V _{USB} = 4.0 V rising to 4.4 V, CAP = 0.01 μF, I _{OUT} = 10 mA	25°C		18		μs
			Full			50	
t _{OFF}	VOUT OFF-time	EN high to low, C(VOUT) = 1 μF, VOUT load = 360 Ω	Full		32		μs
t _{ON}	VOUT ON-time	EN low to high, C(VOUT) = open, VOUT load = 360 Ω	Full		65		μs

(1) V_{IN} is defined as the highest voltage present on the BAT, USB and DC_IN pins.

(2) One of the voltages on BAT, USB and DC_IN must be > V_{IN} (Min), others can be 0 V.

(3) V_{BAT}, V_{USB} and V_{DC_IN} refer to the voltages on BAT, USB and DC_IN respectively. I_{OUT}, I_{OUT-VOUT} and I_{OUT-LOUT} refer to the currents for the combined output current for VOUT and LOUT, the current on VOUT and the current on LOUT respectively.

(4) TYP is 25°C, BAT = 4.2-V, USB = 0-V, DC_IN = 0-V.

(5) Dropout voltage is the minimum input to output voltage differential needed to maintain regulation at a specified output current. In dropout, the output voltage is equal to: V_{IN} – V_{DROPOUT}.

(6) Dropout voltage is measured at the V_{IN} that causes the output to drop to 100mV below its nominal voltage. For VOUT, the voltage drop across the output switch is included (10mA × R_{ONVOUT}).

6.6 Typical Characteristics

Table 1. Performance Graphs and Plots

Type	Description	Figure
Graph	RON versus VIN (BAT, USB, DC_IN) 25°C	Figure 1
Graph	RON versus VIN (Any input)	Figure 2
Graph	Quiescent Current versus Input Voltage (Any input)	Figure 3
Graph	Operating Current versus Input Voltage (Any Input)	Figure 4
Scope Plot	t_{OFF} (VIN = 4.2 V, C(VOUT) = 1 uF, 25°C)	Figure 5
Scope Plot	t_{OFF} (VIN = 4.2 V, C(VOUT) = open, 25°C)	Figure 6
Scope Plot	t_{ON} (VIN = 4.2 V, C(VOUT) = 1 uF, 25°C)	Figure 7
Scope Plot	t_{ON} (VIN = 4.2 V, C(VOUT) = open, 25°C)	Figure 8
Graph	LOUT and VOUT versus Temperature at VIN = 4.2 V	Figure 9
Graph	LOUT and VOUT versus IOU (VIN = 4.2 V, Temp = 25°C)	Figure 10
Graph	LOUT Dropout Voltage versus Temperature (VIN = 2.5 V)	Figure 11
Graph	VOUT Dropout Voltage versus Temperature (VIN = 2.5 V)	Figure 12
Graph	Output Pulldown Resistance (R_{PD}) versus Temperature (10 mA into VOUT)	Figure 13

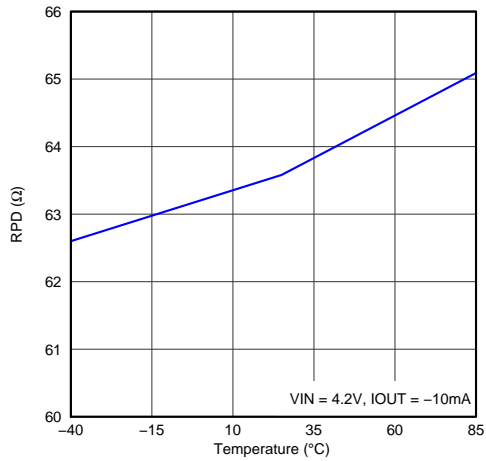

Figure 1. RPD vs Temperature

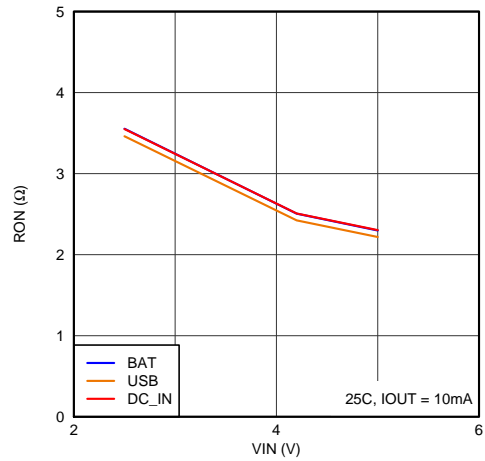

Figure 2. RON vs VIN (Typical)

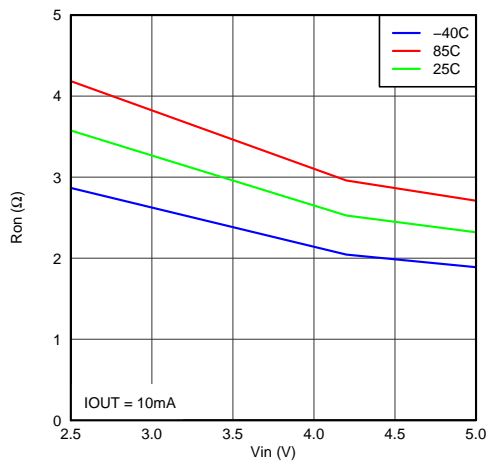

Figure 3. RON vs VIN

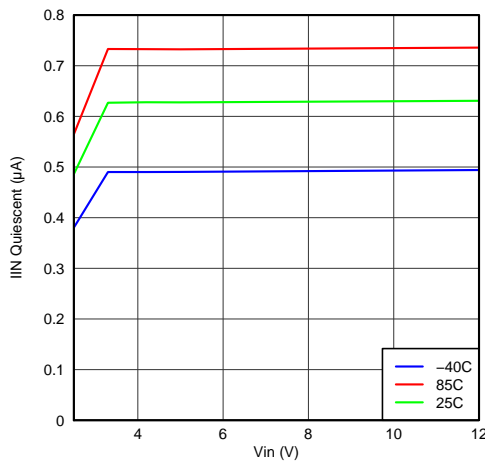

Figure 4. IIN (Quiescent) vs VIN

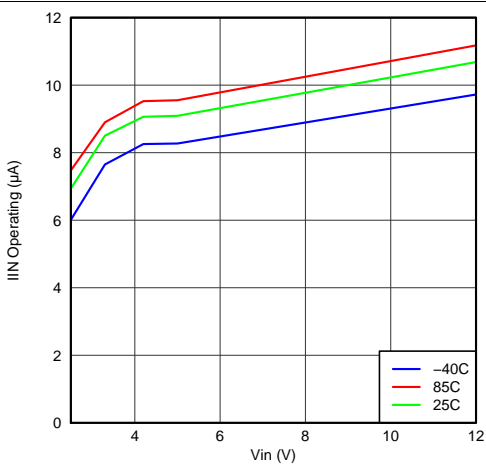

Figure 5. IIN (Operating) vs VIN

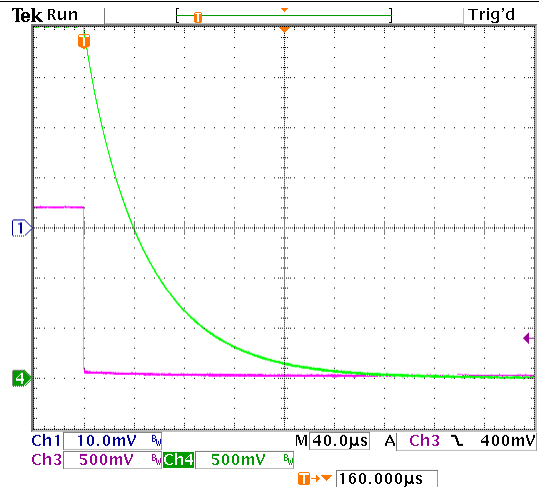

Figure 6. VOUT toff (1 μF on VOUT)

17 Sep 2011
11:19:34

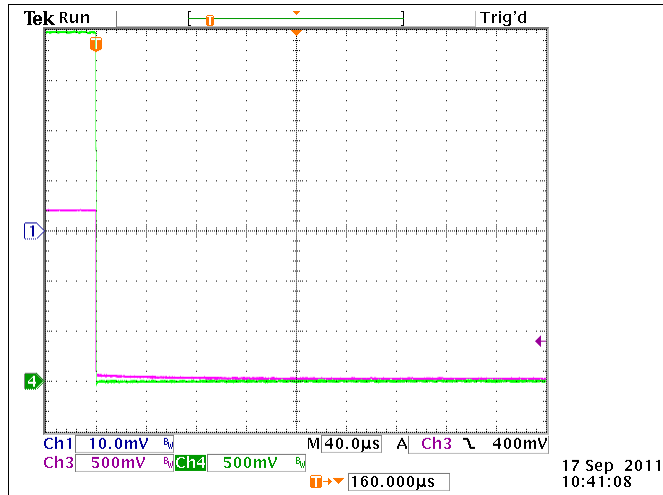

Figure 7. VOUT t_{OFF} (No Capacitor on VOUT)

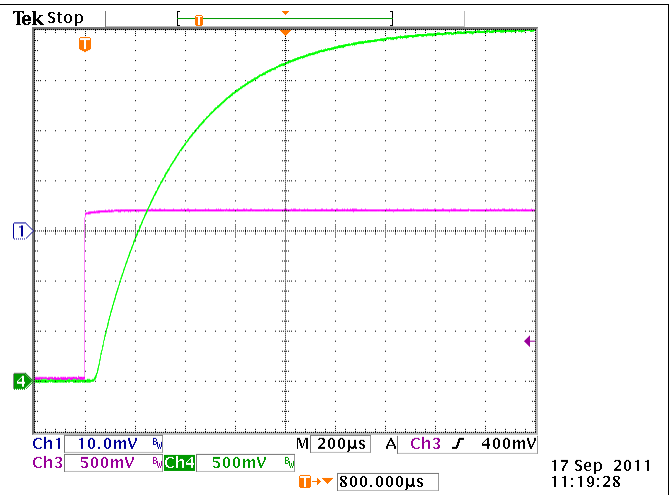

Figure 8. VOUT t_{ON} (1 μ F on VOUT)

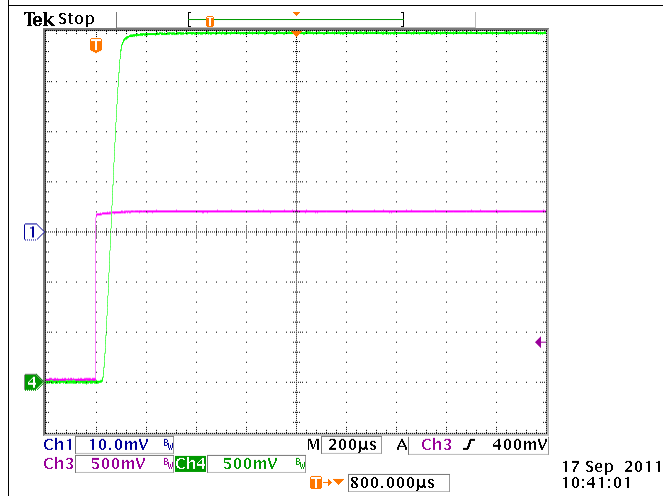

Figure 9. VOUT t_{ON} (No Capacitor on VOUT)

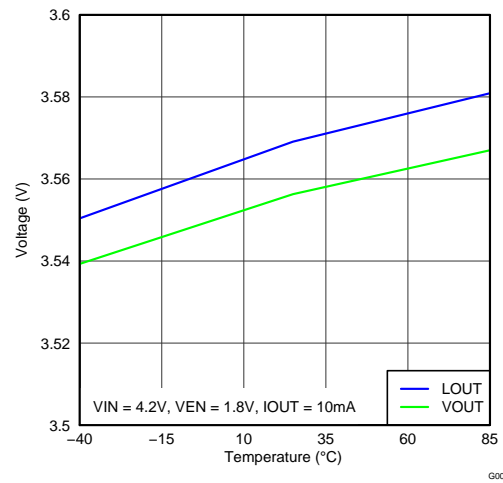

Figure 10. LOU-VOUT vs Temperature VIN 4.2 V

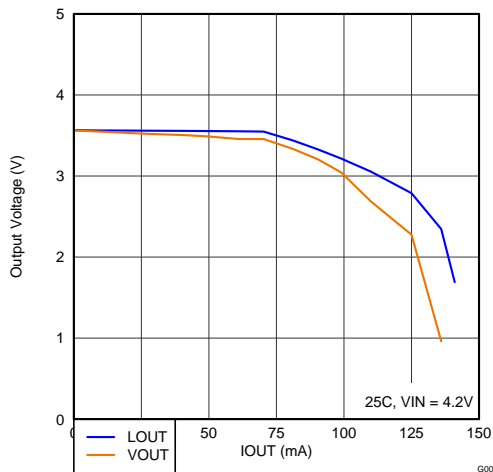

Figure 11. LOU-VOUT vs IOU

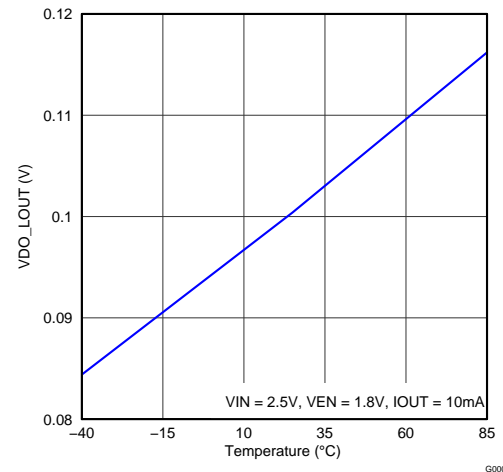

Figure 12. VDOLOU vs Temperature VIN 2.5 V

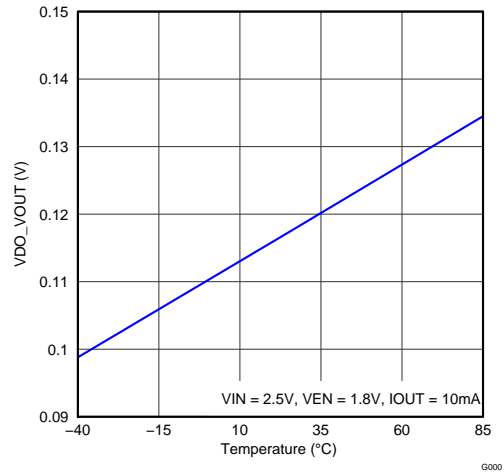

Figure 13. VDOVOUT vs Temperature VIN 2.5 V

7 Parametric Measurement Information

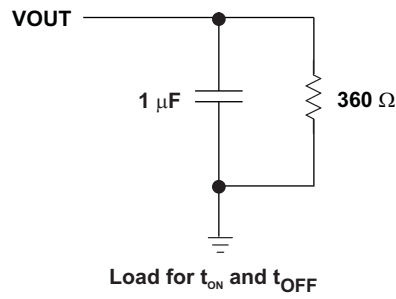

Figure 14. Test Circuit and t_{ON} / t_{OFF} Waveforms

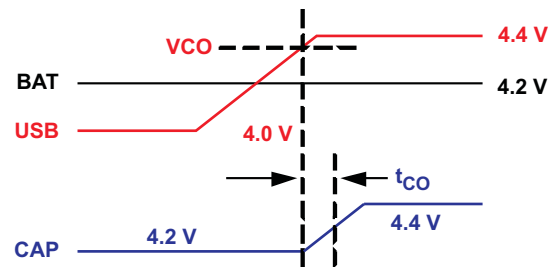

Figure 15. Switchover Timing

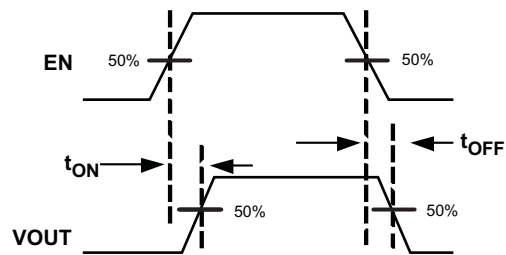

Figure 16. VOUT Enable Timing

8 Detailed Description

8.1 Overview

The TPS22933 is a triple-input power multiplexer with auto-input selection and a low dropout linear regulator. The device contains three P-channel MOSFETs that can operate over an input voltage range of 2.5 V to 12 V. The TPS22933 automatically selects the highest voltage level (from BAT, USB, and DC_IN) and enables that input to source the LDO. LOUT is an always-on output from the LDO, but VOUT can be switched on and off using the EN pin.

8.2 Functional Block Diagram

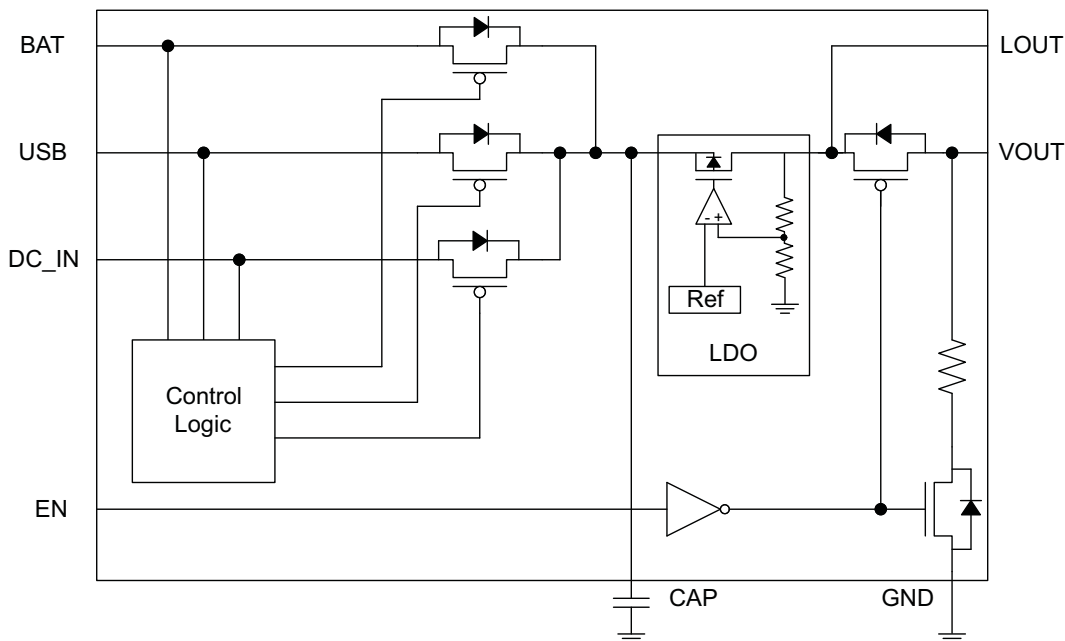

8.3 Feature Description

8.3.1 ON and OFF Control

The EN pin controls the state of the VOUT switch and VOUT pulldown switch. EN has no control over LOUT. Asserting EN enables the VOUT switch and disables the Quick Output Discharge (QOD) switch. Deasserting EN disables the VOUT switch and enables the QOD switch. EN is active high and has a low threshold, making it capable of interfacing with low voltage signals. The EN pin is compatible with standard GPIO Logic threshold and can be used with any microcontroller with 1.2-V, 1.8-V, 2.5-V or 3.3-V GPIOs.

8.3.2 Power Changeover

The TPS22933 LDO is powered by the highest level input. When input voltages change, the TPS22933 may change which input powers the LDO. During initial power up, the input that reaches the highest value first will power the LDO. Once that decision is made, changing between input sources is based on VCO. When an input source becomes VCO over the input currently supplying power to the LDO, changeover will occur and the new, higher input will power the LDO.

8.4 Device Functional Modes

Table 2 and Table 3 show the behavior of the device with various voltage conditions for the inputs and enable pin.

Table 2. Function Table

EN	LDO TO LOUT	LDO TO VOUT	VOUT TO GND
L	ON	OFF	ON
H	ON	ON	OFF

Table 3. Input Selection Table (V1 > V2 > V3)

BAT	USB	DC_IN	LDO SUPPLY
V1	V2 or V3	V2 or V3	BAT
V2 or V3	V1	V2 or V3	USB
V2 or V3	V2 or V3	V1	DC_IN
V1	V1	V1	See ⁽¹⁾

(1) Whichever source achieves the highest level the fastest will supply the LDO.

9 Application and Implementation

NOTE

Information in the following applications sections is not part of the TI component specification, and TI does not warrant its accuracy or completeness. TI's customers are responsible for determining suitability of components for their purposes. Customers should validate and test their design implementation to confirm system functionality.

9.1 Application Information

9.1.1 LDO Capacitor (for CAP Pin)

An optional capacitor on the CAP pin helps stabilize the integrated LDO. Take care in capacitor sizing to reduce inrush currents. The voltage on the CAP pin will follow the highest input. Since the max input voltage is 12 V, the capacitor voltage rating must be higher than 12 V.

9.1.2 Using the CAP Pin as a Power Output

Figure 17 shows three power inputs multiplexed to source only through the CAP pin. In this case, the LDO outputs are not used (EN is tied low). The highest of the inputs is chosen to drive the voltage at the CAP pin.

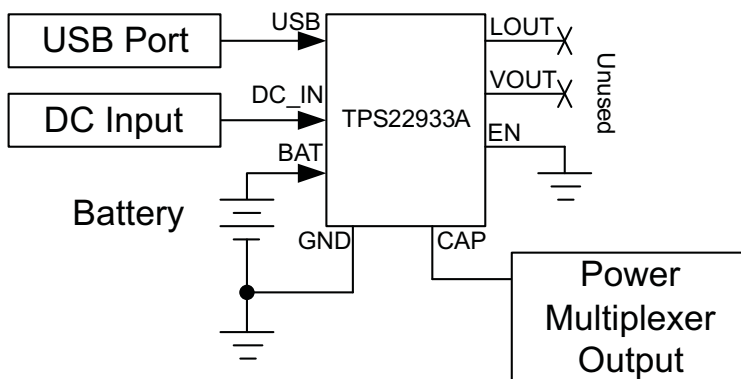

Figure 17. Using the CAP Pin as a Multiplexer Output

9.2 Typical Application

Figure 18 shows three power inputs multiplexed to source the LDO. The LDO always on output (LOUT) is tied to an MSP430. The MSP430 then determines when to enable the switched output (VOUT) by driving the EN pin.

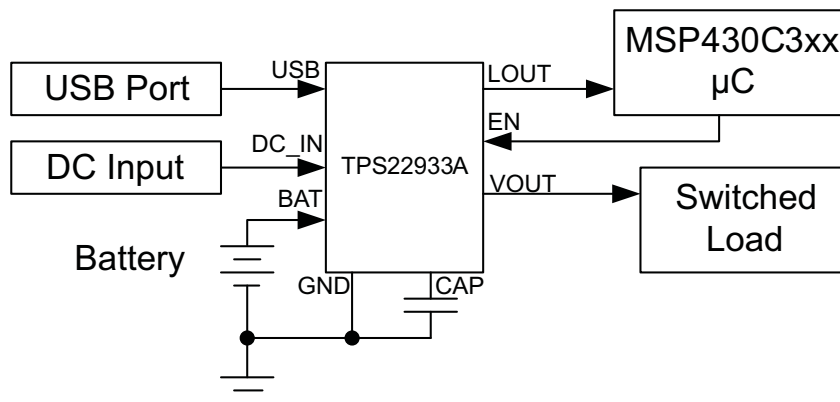

Figure 18. Application Example

Typical Application (continued)

9.2.1 Design Requirements

Table 4 lists the design parameters for TPS22933.

Table 4. Design Parameters

INPUT	VOLTAGE
USB Port	5.0V
DC Input	5.0V
Battery	4.2V

9.2.2 Detailed Design Procedure

Initial power up:

DC_IN = 0 V; USB = 0 V; EN = 0 V

BAT is applied at 4.2 V

LDO power comes from BAT

LOUT = 3.6 V; CAP = 4.2 V; VOUT = 0 V

USB power is connected at 5 V, BAT remains 4.2 V and DC_IN remains 0 V

LDO power is changed from BAT to USB in t_{CO}

LOUT = 3.6 V; CAP = 5 V; VOUT = 0 V

DC_IN power is connected at 5.0 V, BAT remains 4.2 V and USB remains 5 V

No change in LDO power

LOUT = 3.6 V; CAP = 5 V; VOUT = 0 V

EN = VIH, BAT remains 4.2 V, USB remains 5 V and DC_IN remains 5 V

LOUT = 3.6 V, CAP = 5 V; VOUT = 3.6 V

USB power is removed, BAT remains 4.2 V and DC_IN remains 5 V

LDO power is changed from USB to DC_IN

LOUT = 3.6 V; CAP = 5 V; VOUT = 3.6 V

DC_IN power is removed, BAT remains 4.2 V and USB remains 0 V:

LDO power is changed from DC_IN to BAT

LOUT = 3.6 V; CAP = 4.2 V; VOUT = 3.6 V

9.2.3 Application Curve

Figure 19 shows the device behavior in the last step of the design procedure, when DC_IN power is removed and the LDO is powered by the battery. The capacitor on the CAP pin discharges as DC_IN is removed but then charges to the battery voltage when the input is automatically switched. LOUT remains a constant 3.6 V throughout this power switching.

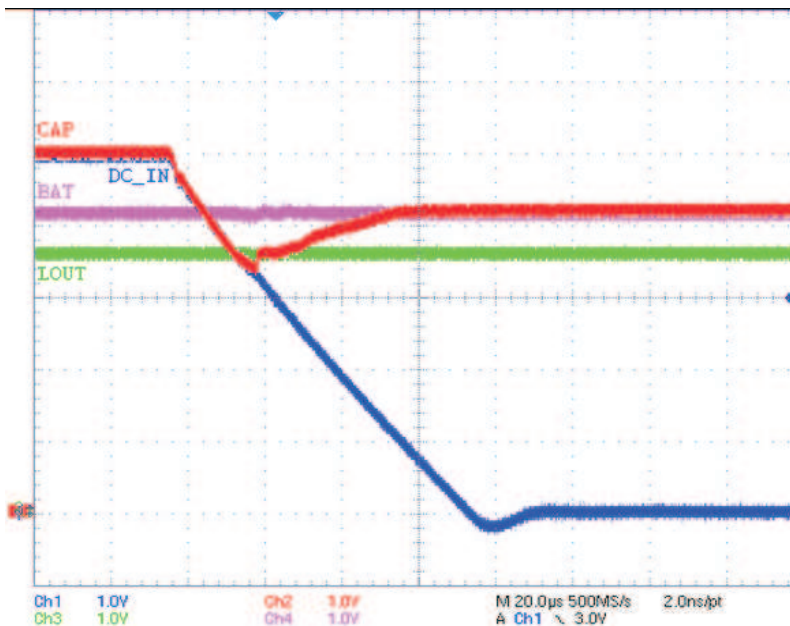

Figure 19. DC_IN Removed, BAT Powers LDO (LOUT = 3.6 V)

10 Power Supply Recommendations

The device is designed to operate with an input voltage range of 2.5 V to 12 V. This supply must be well regulated and placed as close to the device terminals as possible.

11 Layout

11.1 Layout Guidelines

For best performance, all traces should be as short as possible. To be most effective, the input and output capacitors should be placed close to the device to minimize the effects that parasitic trace inductances may have on normal and short-circuit operation. Using wide traces for BAT, USB, DC_IN, LOUT, VOUT, and GND will help minimize the parasitic electrical effects along with minimizing the case to ambient thermal impedance.

11.2 Layout Example

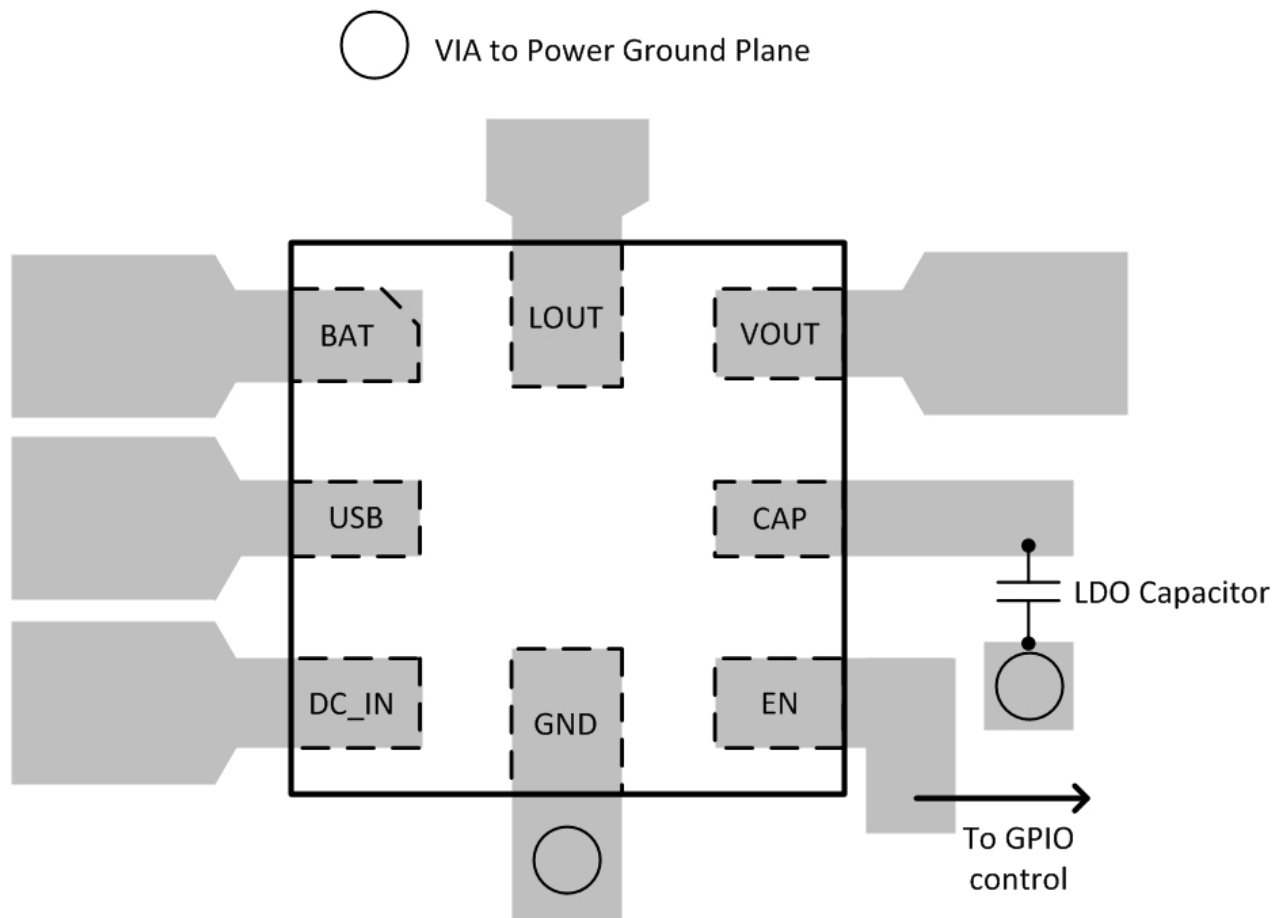

Figure 20. TPS22933 Layout Example

12 器件和文档支持

12.1 社区资源

The following links connect to TI community resources. Linked contents are provided "AS IS" by the respective contributors. They do not constitute TI specifications and do not necessarily reflect TI's views; see TI's [Terms of Use](#).

TI E2E™ Online Community *TI's Engineer-to-Engineer (E2E) Community*. Created to foster collaboration among engineers. At e2e.ti.com, you can ask questions, share knowledge, explore ideas and help solve problems with fellow engineers.

Design Support *TI's Design Support* Quickly find helpful E2E forums along with design support tools and contact information for technical support.

12.2 商标

E2E is a trademark of Texas Instruments.
All other trademarks are the property of their respective owners.

12.3 静电放电警告



这些装置包含有限的内置 ESD 保护。存储或装卸时，应将导线一起截短或将装置放置于导电泡棉中，以防止 MOS 门极遭受静电损伤。

12.4 Glossary

[SLYZ022](#) — *TI Glossary*.

This glossary lists and explains terms, acronyms, and definitions.

13 机械、封装和可订购信息

以下页中包括机械封装和可订购信息。这些信息是针对指定器件可提供的最新数据。这些数据会在无通知且不对本文档进行修订的情况下发生改变。欲获得该数据表的浏览器版本，请查阅左侧的导航栏。

重要声明

德州仪器(TI)及其下属子公司有权根据 JESD46 最新标准,对所提供的产品和服务进行更正、修改、增强、改进或其它更改,并有权根据 JESD48 最新标准中止提供任何产品和服务。客户在下订单前应获取最新的相关信息,并验证这些信息是否完整且是最新的。所有产品的销售都遵循在订单确认时所提供的TI 销售条款与条件。

TI 保证其所销售的组件的性能符合产品销售时 TI 半导体产品销售条件与条款的适用规范。仅在 TI 保证的范围内,且 TI 认为有必要时才会使用测试或其它质量控制技术。除非适用法律做出了硬性规定,否则没有必要对每种组件的所有参数进行测试。

TI 对应用帮助或客户产品设计不承担任何义务。客户应对其使用 TI 组件的产品和应用自行负责。为尽量减小与客户产品和应用相关的风险,客户应提供充分的设计与操作安全措施。

TI 不对任何 TI 专利权、版权、屏蔽作品权或其它与使用了 TI 组件或服务的组合设备、机器或流程相关的 TI 知识产权中授予的直接或隐含权限作出任何保证或解释。TI 所发布的与第三方产品或服务有关的信息,不能构成从 TI 获得使用这些产品或服务的许可、授权、或认可。使用此类信息可能需要获得第三方的专利权或其它知识产权方面的许可,或是 TI 的专利权或其它知识产权方面的许可。

对于 TI 的产品手册或数据表中 TI 信息的重要部分,仅在没有对内容进行任何篡改且带有相关授权、条件、限制和声明的情况下才允许进行复制。TI 对此类篡改过的文件不承担任何责任或义务。复制第三方的信息可能需要服从额外的限制条件。

在转售 TI 组件或服务时,如果对该组件或服务参数的陈述与 TI 标明的参数相比存在差异或虚假成分,则会失去相关 TI 组件或服务的所有明示或暗示授权,且这是不正当的、欺诈性商业行为。TI 对任何此类虚假陈述均不承担任何责任或义务。

客户认可并同意,尽管任何应用相关信息或支持仍可能由 TI 提供,但他们将独立负责满足与其产品及其在应用中使用的 TI 产品相关的所有法律、法规和安全相关要求。客户声明并同意,他们具备制定与实施安全措施所需的全部专业技术和知识,可预见故障的危险后果、监测故障及其后果、降低有可能造成人身伤害的故障的发生机率并采取适当的补救措施。客户将全额赔偿因在此类安全关键应用中使用任何 TI 组件而对 TI 及其代理造成的任何损失。

在某些场合中,为了推进安全相关应用有可能对 TI 组件进行特别的促销。TI 的目标是利用此类组件帮助客户设计和创立其特有的可满足适用的功能安全性标准和要求的终端产品解决方案。尽管如此,此类组件仍然服从这些条款。

TI 组件未获得用于 FDA Class III (或类似的生命攸关医疗设备)的授权许可,除非各方授权官员已经达成了专门管控此类使用的特别协议。

只有那些 TI 特别注明属于军用等级或“增强型塑料”的 TI 组件才是设计或专门用于军事/航空应用或环境的。购买者认可并同意,对并非指定面向军事或航空航天用途的 TI 组件进行军事或航空航天方面的应用,其风险由客户单独承担,并且由客户独立负责满足与此类使用相关的所有法律和法规要求。

TI 已明确指定符合 ISO/TS16949 要求的产品,这些产品主要用于汽车。在任何情况下,因使用非指定产品而无法达到 ISO/TS16949 要求, TI 不承担任何责任。

	产品		应用
数字音频	www.ti.com.cn/audio	通信与电信	www.ti.com.cn/telecom
放大器和线性器件	www.ti.com.cn/amplifiers	计算机及周边	www.ti.com.cn/computer
数据转换器	www.ti.com.cn/dataconverters	消费电子	www.ti.com.cn/consumer-apps
DLP® 产品	www.dlp.com	能源	www.ti.com.cn/energy
DSP - 数字信号处理器	www.ti.com.cn/dsp	工业应用	www.ti.com.cn/industrial
时钟和计时器	www.ti.com.cn/clockandtimers	医疗电子	www.ti.com.cn/medical
接口	www.ti.com.cn/interface	安防应用	www.ti.com.cn/security
逻辑	www.ti.com.cn/logic	汽车电子	www.ti.com.cn/automotive
电源管理	www.ti.com.cn/power	视频和影像	www.ti.com.cn/video
微控制器 (MCU)	www.ti.com.cn/microcontrollers		
RFID 系统	www.ti.com.cn/rfidsys		
OMAP应用处理器	www.ti.com/omap		
无线连通性	www.ti.com.cn/wirelessconnectivity	德州仪器在线技术支持社区	www.deyisupport.com

邮寄地址: 上海市浦东新区世纪大道1568号, 中建大厦32楼邮政编码: 200122
Copyright © 2016, 德州仪器半导体技术(上海)有限公司

PACKAGING INFORMATION

Orderable Device	Status (1)	Package Type	Package Drawing	Pins	Package Qty	Eco Plan (2)	Lead finish/ Ball material (6)	MSL Peak Temp (3)	Op Temp (°C)	Device Marking (4/5)	Samples
TPS22933ARSER	ACTIVE	UQFN	RSE	8	3000	RoHS & Green	NIPDAUAG	Level-1-260C-UNLIM	-40 to 85	4Q	Samples
TPS22933ARSET	ACTIVE	UQFN	RSE	8	250	RoHS & Green	NIPDAUAG	Level-1-260C-UNLIM	-40 to 85	4Q	Samples

(1) The marketing status values are defined as follows:

ACTIVE: Product device recommended for new designs.

LIFEBUY: TI has announced that the device will be discontinued, and a lifetime-buy period is in effect.

NRND: Not recommended for new designs. Device is in production to support existing customers, but TI does not recommend using this part in a new design.

PREVIEW: Device has been announced but is not in production. Samples may or may not be available.

OBSOLETE: TI has discontinued the production of the device.

(2) **RoHS:** TI defines "RoHS" to mean semiconductor products that are compliant with the current EU RoHS requirements for all 10 RoHS substances, including the requirement that RoHS substance do not exceed 0.1% by weight in homogeneous materials. Where designed to be soldered at high temperatures, "RoHS" products are suitable for use in specified lead-free processes. TI may reference these types of products as "Pb-Free".

RoHS Exempt: TI defines "RoHS Exempt" to mean products that contain lead but are compliant with EU RoHS pursuant to a specific EU RoHS exemption.

Green: TI defines "Green" to mean the content of Chlorine (Cl) and Bromine (Br) based flame retardants meet JS709B low halogen requirements of <=1000ppm threshold. Antimony trioxide based flame retardants must also meet the <=1000ppm threshold requirement.

(3) MSL, Peak Temp. - The Moisture Sensitivity Level rating according to the JEDEC industry standard classifications, and peak solder temperature.

(4) There may be additional marking, which relates to the logo, the lot trace code information, or the environmental category on the device.

(5) Multiple Device Markings will be inside parentheses. Only one Device Marking contained in parentheses and separated by a "~" will appear on a device. If a line is indented then it is a continuation of the previous line and the two combined represent the entire Device Marking for that device.

(6) Lead finish/Ball material - Orderable Devices may have multiple material finish options. Finish options are separated by a vertical ruled line. Lead finish/Ball material values may wrap to two lines if the finish value exceeds the maximum column width.

Important Information and Disclaimer:The information provided on this page represents TI's knowledge and belief as of the date that it is provided. TI bases its knowledge and belief on information provided by third parties, and makes no representation or warranty as to the accuracy of such information. Efforts are underway to better integrate information from third parties. TI has taken and continues to take reasonable steps to provide representative and accurate information but may not have conducted destructive testing or chemical analysis on incoming materials and chemicals. TI and TI suppliers consider certain information to be proprietary, and thus CAS numbers and other limited information may not be available for release.

In no event shall TI's liability arising out of such information exceed the total purchase price of the TI part(s) at issue in this document sold by TI to Customer on an annual basis.

TAPE AND REEL INFORMATION

QUADRANT ASSIGNMENTS FOR PIN 1 ORIENTATION IN TAPE



*All dimensions are nominal

Device	Package Type	Package Drawing	Pins	SPQ	Reel Diameter (mm)	Reel Width W1 (mm)	A0 (mm)	B0 (mm)	K0 (mm)	P1 (mm)	W (mm)	Pin1 Quadrant
TPS22933ARSER	UQFN	RSE	8	3000	180.0	8.4	1.7	1.7	0.7	4.0	8.0	Q2
TPS22933ARSET	UQFN	RSE	8	250	180.0	8.4	1.7	1.7	0.7	4.0	8.0	Q2

TAPE AND REEL BOX DIMENSIONS

*All dimensions are nominal

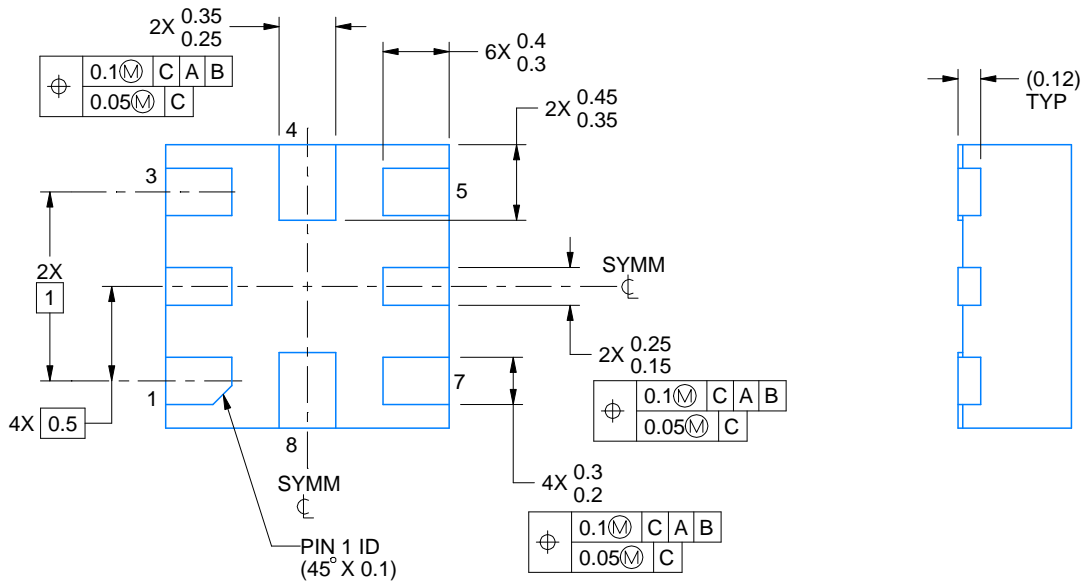
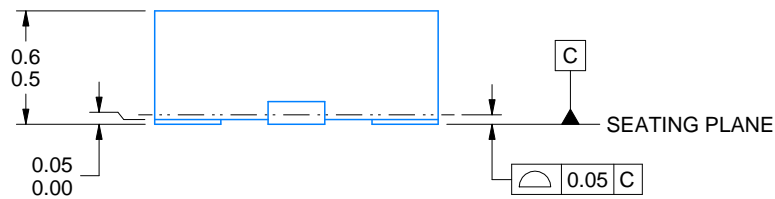
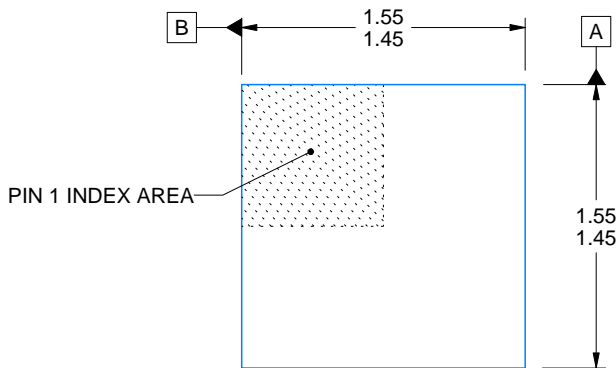
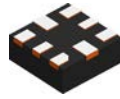
Device	Package Type	Package Drawing	Pins	SPQ	Length (mm)	Width (mm)	Height (mm)
TPS22933ARSER	UQFN	RSE	8	3000	202.0	201.0	28.0
TPS22933ARSET	UQFN	RSE	8	250	202.0	201.0	28.0



4220323/B 03/2018

NOTES:

1. All linear dimensions are in millimeters. Any dimensions in parenthesis are for reference only. Dimensioning and tolerancing per ASME Y14.5M.
2. This drawing is subject to change without notice.

EXAMPLE BOARD LAYOUT

RSE0008A

UQFN - 0.6 mm max height

PLASTIC QUAD FLATPACK - NO LEAD

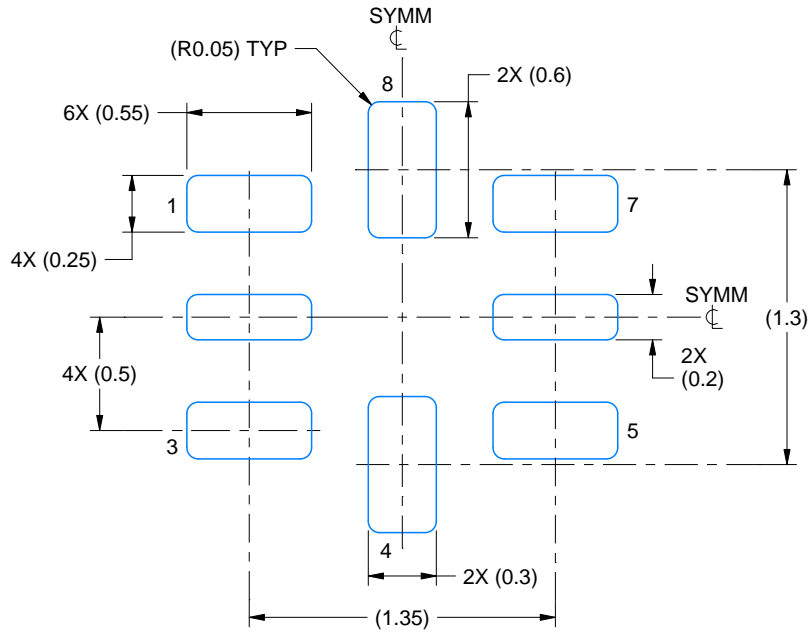

LAND PATTERN EXAMPLE
SCALE:30X

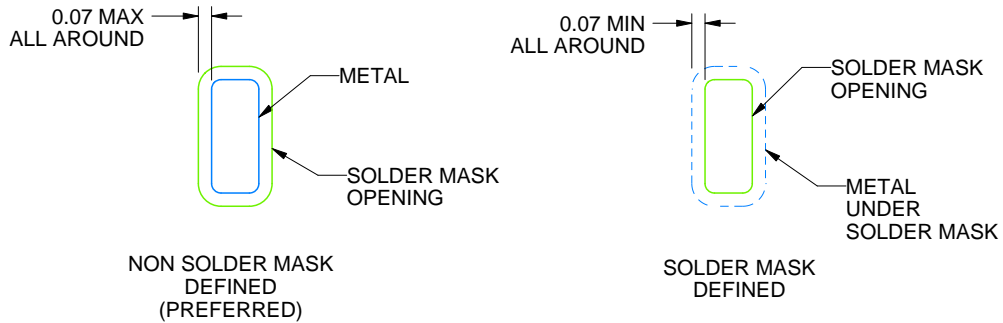

SOLDER MASK DETAILS
NOT TO SCALE

4220323/B 03/2018

NOTES: (continued)

3. For more information, see Texas Instruments literature number SLUA271 (www.ti.com/lit/slua271).

EXAMPLE STENCIL DESIGN

RSE0008A

UQFN - 0.6 mm max height

PLASTIC QUAD FLATPACK - NO LEAD

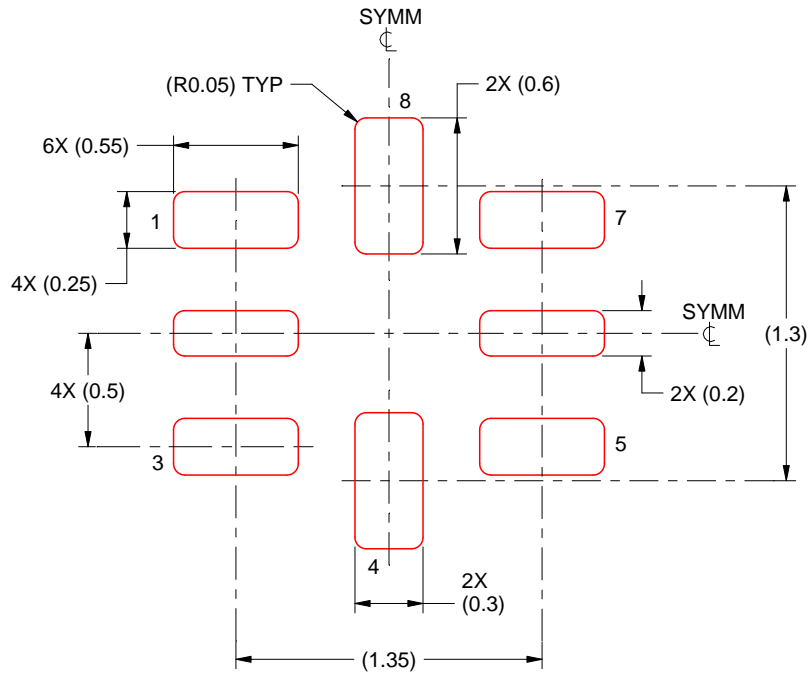

SOLDER PASTE EXAMPLE
BASED ON 0.1 mm THICKNESS
SCALE: 30X

4220323/B 03/2018

NOTES: (continued)

5. Laser cutting apertures with trapezoidal walls and rounded corners may offer better paste release. IPC-7525 may have alternate design recommendations.

重要声明和免责声明

TI 均以“原样”提供技术性及其可靠性数据（包括数据表）、设计资源（包括参考设计）、应用或其他设计建议、网络工具、安全信息和其他资源，不保证其中不含任何瑕疵，且不做任何明示或暗示的担保，包括但不限于对适销性、适合某特定用途或不侵犯任何第三方知识产权的暗示担保。

所述资源可供专业开发人员应用TI 产品进行设计使用。您将对以下行为独自承担全部责任：(1) 针对您的应用选择合适的TI 产品；(2) 设计、验证并测试您的应用；(3) 确保您的应用满足相应标准以及任何其他安全、安保或其他要求。所述资源如有变更，恕不另行通知。TI 对您使用所述资源的授权仅限于开发资源所涉及TI 产品的相关应用。除此之外不得复制或展示所述资源，也不提供其它TI 或任何第三方的知识产权授权许可。如因使用所述资源而产生任何索赔、赔偿、成本、损失及债务等，TI 对此概不负责，并且您须赔偿由此对TI 及其代表造成的损害。

TI 所提供产品均受TI 的销售条款 (<http://www.ti.com.cn/zh-cn/legal/termsofsale.html>) 以及ti.com.cn上或随附TI产品提供的其他可适用条款的约束。TI提供所述资源并不扩展或以其他方式更改TI 针对TI 产品所发布的可适用的担保范围或担保免责声明。

邮寄地址：上海市浦东新区世纪大道 1568 号中建大厦 32 楼，邮政编码：200122

Copyright © 2020 德州仪器半导体技术（上海）有限公司