

CDx4HC251, CDx4HCT251 High-Speed CMOS Logic 8-Input Multiplexer, Three-State

1 Features

- Selects one of eight binary data inputs
- Three-state output capability
- True and complement outputs
- Typical (data to output) propagation delay of 14 ns at $V_{CC} = 5\text{ V}$, $C_L = 15\text{ pF}$, $T_A = 25\text{ }^\circ\text{C}$
- Fanout (over temperature range)
 - Standard outputs : 10 LSTTL loads
 - Bus driver outputs : 15 LSTTL loads
- Wide operating temperature range : $-55\text{ }^\circ\text{C}$ to $125\text{ }^\circ\text{C}$
- Balanced propagation delay and transition times
- Significant power reduction compared to LSTTL logic ICs
- Alternate source is Philips
- HC types
 - 2 V to 6 V operation
 - High noise immunity : $N_{IL} = 30\%$, $N_{IH} = 30\%$ of V_{CC} at $V_{CC} = 5\text{ V}$
- HCT types
 - 4.5 V to 5.5 V operation
 - Direct LSTTL input logic compatibility, $V_{IL} = 0.8\text{ V}$ (Max), $V_{IH} = 2\text{ V}$ (Min)
 - CMOS input compatibility, $I_I \leq 1\text{ }\mu\text{A}$ at V_{OL} , V_{OH}

2 Description

The 'HC251 and 'HCT251 are 8-channel digital multiplexers with three-state outputs, fabricated with high-speed silicongate CMOS technology. Together with the low power consumption of standard CMOS integrated circuits, they possess the ability to drive 10 LSTTL loads. The three-state feature makes them ideally suited for interfacing with bus lines in a bus-oriented system.

Device Information

PART NUMBER	PACKAGE ⁽¹⁾	BODY SIZE (NOM)
CD54HC251F	CDIP (16)	24.38 mm × 6.92 mm
CD54HCT251F	CDIP (16)	24.38 mm × 6.92 mm
CD74HC251M	SOIC (16)	9.90 mm × 3.90 mm
CD74HCT251M	SOIC (16)	9.90 mm × 3.90 mm
CD74HC251E	PDIP (16)	19.31 mm × 6.35 mm
CD74HCT251E	PDIP (16)	19.31 mm × 6.35 mm

(1) For all available packages, see the orderable addendum at the end of the data sheet.

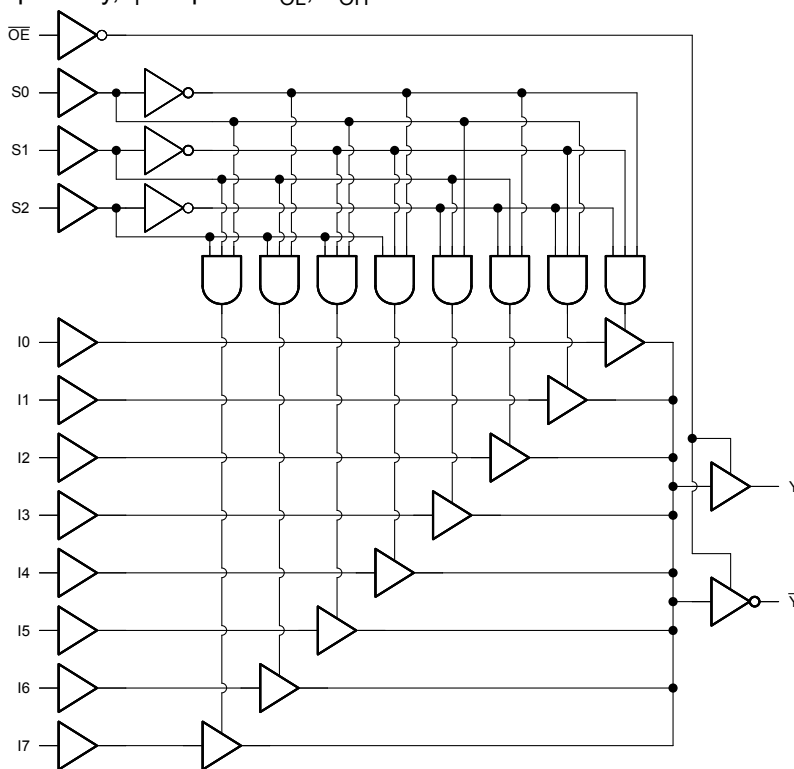

Functional Block Diagram



Table of Contents

1 Features	1	7.3 Device Functional Modes.....	10
2 Description	1	8 Power Supply Recommendations	11
3 Revision History	2	9 Layout	11
4 Pin Configuration and Functions	3	9.1 Layout Guidelines.....	11
5 Specifications	4	10 Device and Documentation Support	12
5.1 Absolute Maximum Ratings.....	4	10.1 Documentation Support.....	12
5.2 Recommended Operating Conditions ⁽¹⁾	4	10.2 Receiving Notification of Documentation Updates..	12
5.3 Thermal Information.....	4	10.3 Support Resources.....	12
5.4 Electrical Characteristics.....	5	10.4 Trademarks.....	12
5.5 Switching Characteristics.....	6	10.5 Electrostatic Discharge Caution.....	12
6 Parameter Measurement Information	7	10.6 Glossary.....	12
7 Detailed Description	9	11 Mechanical, Packaging, and Orderable Information	12
7.1 Overview.....	9		
7.2 Functional Block Diagram.....	9		

3 Revision History

NOTE: Page numbers for previous revisions may differ from page numbers in the current version.

Changes from Revision C (October 2003) to Revision D (March 2022)	Page
• Updated the numbering, formatting, tables, figures, and cross-references throughout the document to reflect modern data sheet standards.....	1

4 Pin Configuration and Functions

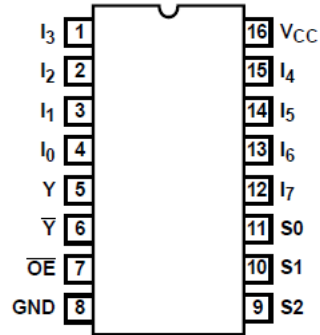

J, N, or D Package
16-Pin CDIP, PDIP, or SOIC
Top View

5 Specifications

5.1 Absolute Maximum Ratings

over operating free-air temperature range (unless otherwise noted)⁽¹⁾

		MIN	MAX	UNIT
V _{CC}	Supply voltage range	-0.5	7	V
I _{IK}	Input diode current ⁽²⁾	V _I < 0.5 V or V _I > V _{CC} + 0.5 V		±20 mA
I _{OK}	Output diode current ⁽²⁾	V _O < -0.5 V or V _O > V _{CC} + 0.5 V		±20 mA
I _O	Drain current, per output	-0.5 V < V _O < V _{CC} + 0.5 V		±25 mA
I _O	Output source or sink current per output pin	V _O > -0.5 V or V _O < V _{CC} + 0.5 V		±25 mA
Continuous current through V _{CC} or GND				±50 mA
T _J	Junction temperature			150 °C
T _{stg}	Storage temperature	-65	150	°C
Lead temperature (Soldering 10s) (SOIC - lead tips only)				300 °C

- (1) Stresses beyond those listed under *absolute maximum ratings* may cause permanent damage to the device. These are stress ratings only and functional operation of the device at these or any other conditions beyond those indicated under *recommended operating conditions* is not implied. Exposure to absolute-maximum-rated conditions for extended periods may affect device reliability.
- (2) The input and output voltage ratings may be exceeded if the input and output current ratings are observed.

5.2 Recommended Operating Conditions⁽¹⁾

		MIN	MAX	UNIT	
V _{CC}	Supply voltage range	HC Types	2	6	V
		HCT Types	4.5	5.5	V
V _I , V _O	DC input or output voltage	0	V _{CC}	V	
t _t	Input rise and fall time	2 V	1000	ns	
		4.5 V	500		
		6 V	400		
T _A	Temperature range	-55	125	°C	

- (1) All unused inputs of the device must be held at V_{CC} or GND to ensure proper device operation. Refer to the TI application report *Implications of Slow or Floating CMOS Inputs*, literature number [SCBA004](#).

5.3 Thermal Information

THERMAL METRIC		D (SOIC)	N (PDIP)	UNIT
		16 PINS	16 PINS	
R _{θJA}	Junction-to-ambient thermal resistance ⁽¹⁾	67	73	°C/W

- (1) For more information about traditional and new thermal metrics, see the [Semiconductor and IC package thermal metrics](#) application report.

5.4 Electrical Characteristics

PARAMETER		TEST CONDITIONS ⁽¹⁾	V _{CC} (V)	25°C			–40°C to 85°C		–55°C to 125°C		UNIT
				MIN	TYP	MAX	MIN	MAX	MIN	MAX	
HC TYPES											
V _{IH}	High-level input voltage		2	1.5		1.5		1.5		V	
			4.5	3.15		3.15		3.15		V	
			6	4.2		4.2		4.2		V	
V _{IL}	Low-level input voltage		2		0.5		0.5		0.5	V	
			4.5		1.35		1.35		1.35	V	
			6		1.8		1.8		1.8	V	
V _{OH}	High-level output voltage CMOS loads	I _{OH} = –20μA	2	1.9		1.9		1.9		V	
		I _{OH} = –20μA	4.5	4.4		4.4		4.4		V	
		I _{OH} = –20μA	6	5.9		5.9		5.9		V	
	High-level output voltage TTL loads	I _{OH} = –6mA	4.5	3.98		3.84		3.7		V	
		I _{OH} = –7.8mA	6	5.48		5.34		5.2		V	
V _{OL}	Low-level output voltage CMOS loads	I _{OL} = 20μA	2		0.1		0.1		0.1	V	
		I _{OL} = 20μA	4.5		0.1		0.1		0.1	V	
		I _{OL} = 20μA	6		0.1		0.1		0.1	V	
	Low-level output voltage TTL loads	I _{OL} = 6mA	4.5		0.26		0.33		0.4	V	
		I _{OL} = 7.8mA	6		0.26		0.33		0.4	V	
I _I	Input leakage current	V _{CC} or GND	6		±0.1		±1		±1	μA	
I _{CC}	Supply current	V _{CC} or GND	6		8		80		160	μA	
I _{OZ}	Three-state leakage current		6		±0.5		±0.5		±10	μA	
HCT TYPES											
V _{IH}	High-level input voltage		4.5 to 5.5	2		2		2		V	
V _{IL}	Low-level input voltage		4.5 to 5.5		0.8		0.8		0.8	V	
V _{OH}	High-level output voltage CMOS loads	I _{OH} = –20μA	4.5	4.4		4.4		4.4		V	
	High-level output voltage TTL loads	I _{OH} = –6mA	4.5	3.98		3.84		3.7		V	
V _{OL}	Low-level output voltage CMOS loads	I _{OL} = 20μA	4.5		0.1		0.1		0.1	V	
	Low-level output voltage TTL loads	I _{OL} = 6mA	4.5		0.26		0.33		0.4	V	
I _I	Input leakage current	V _{CC} and GND	5.5		±0.1		±1		±1	μA	
I _{CC}	Supply Current	V _{CC} and GND	5.5		8		80		160	μA	
I _{OZ}	Three-state leakage current		6		±0.5		±5.0		±10	μA	
ΔI _{CC} ^{(2) (3)}	Additional supply current per input pin	S0, S1, S2	4.5 to 5.5		55 198		247.5		269.5	μA	
		I0 - I7	4.5 to 5.5		50 180		225		245	μA	
		\overline{OE}	4.5 to 5.5		265 954		1192.5		1298.5	μA	

(1) V_I = V_{IH} or V_{IL}, unless otherwise noted.

(2) For dual-supply systems theoretical worst case (V_I = 2.4 V, V_{CC} = 5.5 V) specification is 1.8 mA..

(3) Inputs held at V_{CC} – 2.1.

5.5 Switching Characteristics

Input $t_f = 6\text{ns}$. Unless otherwise specified, $C_L = 50\text{pF}$

PARAMETER		V_{CC} (V)	25°C		-40°C to 85°C	-55°C to 125°C	UNIT
			TYP	MAX	MAX	MAX	
HC TYPES							
t_{pd}	Select to outputs	2		245	305	370	ns
		4.5	21 ⁽¹⁾	49	61	74	
		6		42	52	63	
t_{pd}	Data to outputs	2		175	220	265	ns
		4.5	12 ⁽¹⁾	35	44	53	
		6		30	37	45	
t_{pd}	Enable to high Z and enable from high Z	2		140	175	210	ns
		4.5	11 ⁽¹⁾	28	35	42	
		6		24	30	36	
t_t	Output transition times	2		75	95	110	ns
		4.5		15	19	22	
		6		13	16	19	
C_i	Input capacitance			10	10	10	pF
C_O	Three-state output capacitance			15	15	15	pF
C_{pd} ^{(3) (4)}	Power dissipation capacitance	5	60 ⁽²⁾				pF
HCT TYPES							
t_{pd}	Select to outputs	4.5	18 ⁽¹⁾	42	53	63	ns
t_{pd}	Data to outputs	4.5	12 ⁽¹⁾	35	44	53	ns
t_{pd}	Enable to high Z and enable from high Z	4.5	12 ⁽¹⁾	30	38	45	ns
t_t	Output transition times	4.5		15	19	22	ns
C_i	Input capacitance			10	10	10	pF
C_{pd} ^{(3) (4)}	Power dissipation capacitance	5	60 ⁽²⁾				pF

(1) Typical value tested at 5V, $C_L = 15\text{pF}$.

(2) Typical value tested at 5V.

(3) C_{PD} is used to determine the dynamic power consumption, per channel.

(4) $P_D = V_{CC}^2 f_i (C_{PD} + C_L)$ where f_i = input frequency, C_L = output load capacitance, V_{CC} = supply voltage.

6 Parameter Measurement Information

Phase relationships between waveforms were chosen arbitrarily. All input pulses are supplied by generators having the following characteristics: $PRR \leq 1 \text{ MHz}$, $Z_O = 50 \Omega$, $t_t < 6 \text{ ns}$.

For clock inputs, f_{max} is measured when the input duty cycle is 50%.

The outputs are measured one at a time with one input transition per measurement.

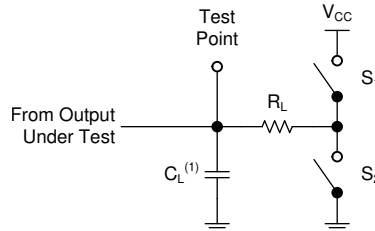

(1) C_L includes probe and test-fixture capacitance.

Figure 6-1. Load Circuit for 3-State Outputs

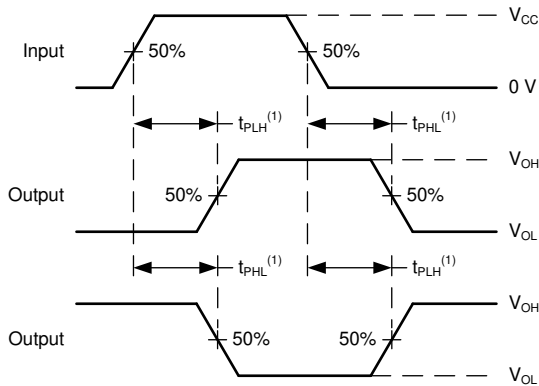

(1) The greater between t_{pLH} and t_{pHL} is the same as t_{pd} .

Figure 6-2. Voltage Waveforms, Propagation Delays for Standard CMOS Inputs

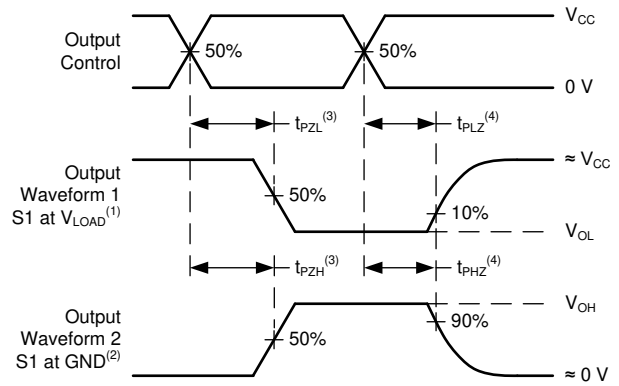

(1) t_{pLZ} and t_{pHZ} are the same as t_{dis} .

(2) t_{pZL} and t_{pZH} are the same as t_{en} .

Figure 6-3. Voltage Waveforms, Standard CMOS Inputs Propagation Delays

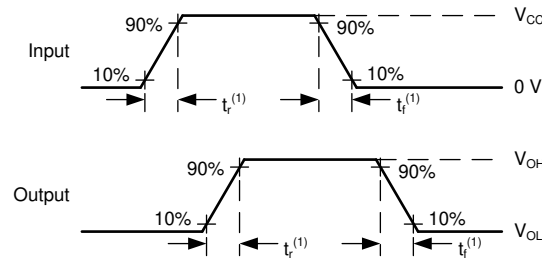

(1) The greater between t_r and t_f is the same as t_t .

Figure 6-4. Voltage Waveforms, Input and Output Transition Times for Standard CMOS Inputs

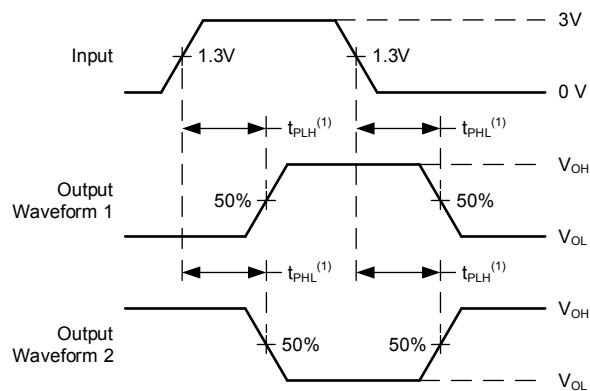

(1) The greater between t_{PLH} and t_{PHL} is the same as t_{pd} .

Figure 6-5. Voltage Waveforms, Propagation Delays for TTL-Compatible Inputs

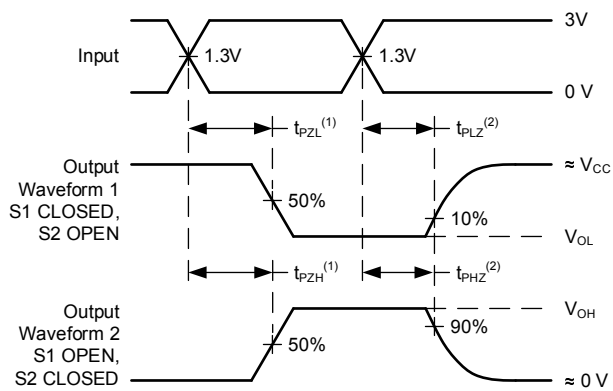

(1) t_{PLZ} and t_{PHZ} are the same as t_{dis} .

(2) t_{PZL} and t_{PZH} are the same as t_{en} .

Figure 6-6. Voltage Waveforms, TTL-Compatible CMOS Inputs Propagation Delays

7 Detailed Description

7.1 Overview

The 'HC251 and 'HCT251 are 8-channel digital multiplexers with three-state outputs, fabricated with high-speed silicongate CMOS technology. Together with the low power consumption of standard CMOS integrated circuits, they possess the ability to drive 10 LSTTL loads. The three-state feature makes them ideally suited for interfacing with bus lines in a bus-oriented system.

This multiplexer features both true (Y) and complement (\bar{Y}) outputs as well as an output enable (\overline{OE}) input. The \overline{OE} must be at a low logic level to enable this device. When the \overline{OE} input is high, both outputs are in the high-impedance state. When enabled, address information on the data select inputs determines which data input is routed to the Y and \bar{Y} outputs. The 'HCT251 logic family is speed, function, and pin-compatible with the standard 'LS251.

7.2 Functional Block Diagram

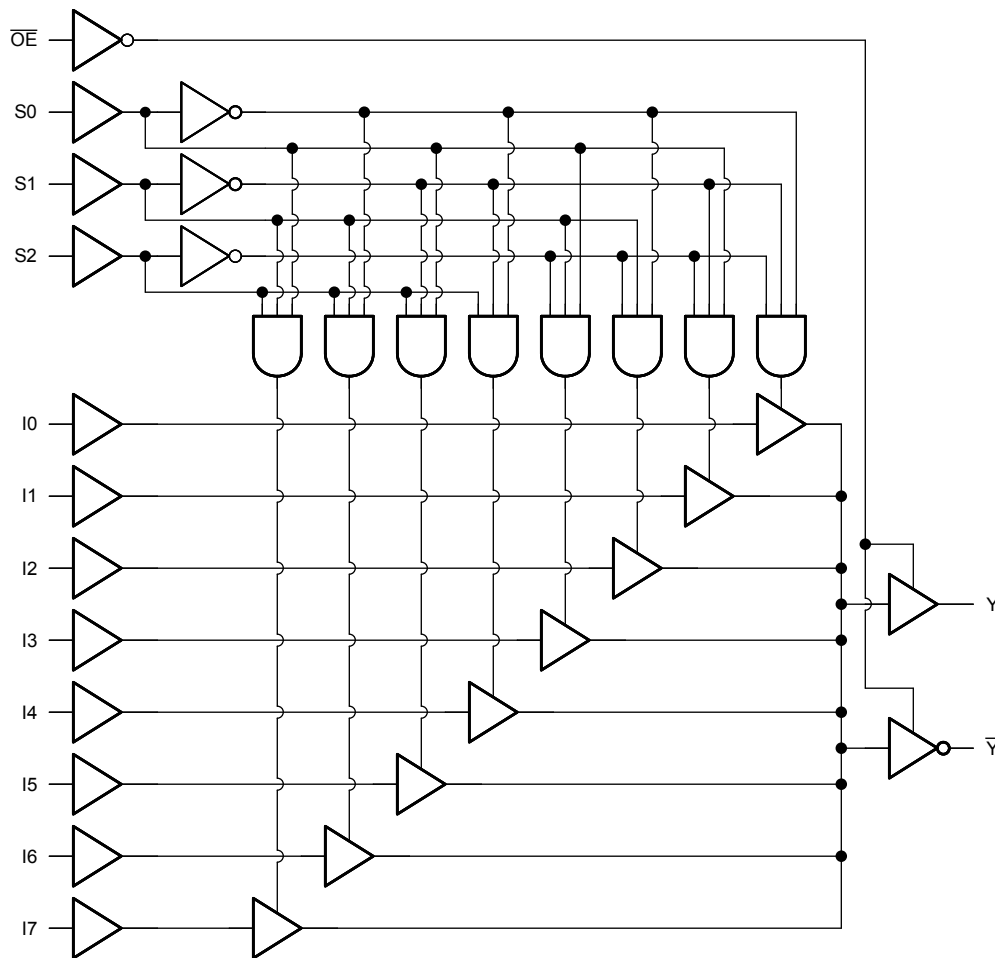

7.3 Device Functional Modes

Table 7-1. Truth Table⁽¹⁾

INPUTS				OUTPUT	
SELECT			OUTPUT CONTROL \overline{OE}	Y	\overline{Y}
S2	S1	S0			
X	X	X	H	Z	Z
L	L	L	L	I ₀	\overline{I}_0
L	L	H	L	I ₁	\overline{I}_1
L	H	L	L	I ₂	\overline{I}_2
L	H	H	L	I ₃	\overline{I}_3
H	L	L	L	I ₄	\overline{I}_4
H	L	H	L	I ₅	\overline{I}_5
H	H	L	L	I ₆	\overline{I}_6
H	H	H	L	I ₇	\overline{I}_7

- (1) H = High voltage level.
 L = Low voltage level.
 X = Dont care.
 Z = High impedance (Off).
 I₀, I₁... I₇ = The level of the respective input.

8 Power Supply Recommendations

The power supply can be any voltage between the minimum and maximum supply voltage rating located in the *Recommended Operating Conditions*. Each V_{CC} terminal should have a good bypass capacitor to prevent power disturbance. A 0.1- μ F capacitor is recommended for this device. It is acceptable to parallel multiple bypass caps to reject different frequencies of noise. The 0.1- μ F and 1- μ F capacitors are commonly used in parallel. The bypass capacitor should be installed as close to the power terminal as possible for best results.

9 Layout

9.1 Layout Guidelines

When using multiple-input and multiple-channel logic devices inputs must not ever be left floating. In many cases, functions or parts of functions of digital logic devices are unused; for example, when only two inputs of a triple-input AND gate are used or only 3 of the 4 buffer gates are used. Such unused input pins must not be left unconnected because the undefined voltages at the outside connections result in undefined operational states. All unused inputs of digital logic devices must be connected to a logic high or logic low voltage, as defined by the input voltage specifications, to prevent them from floating. The logic level that must be applied to any particular unused input depends on the function of the device. Generally, the inputs are tied to GND or V_{CC} , whichever makes more sense for the logic function or is more convenient.

10 Device and Documentation Support

TI offers an extensive line of development tools. Tools and software to evaluate the performance of the device, generate code, and develop solutions are listed below.

10.1 Documentation Support

10.1.1 Related Documentation

10.2 Receiving Notification of Documentation Updates

To receive notification of documentation updates, navigate to the device product folder on ti.com. Click on *Subscribe to updates* to register and receive a weekly digest of any product information that has changed. For change details, review the revision history included in any revised document.

10.3 Support Resources

TI E2E™ [support forums](#) are an engineer's go-to source for fast, verified answers and design help — straight from the experts. Search existing answers or ask your own question to get the quick design help you need.

Linked content is provided "AS IS" by the respective contributors. They do not constitute TI specifications and do not necessarily reflect TI's views; see TI's [Terms of Use](#).

10.4 Trademarks

TI E2E™ is a trademark of Texas Instruments.
All trademarks are the property of their respective owners.

10.5 Electrostatic Discharge Caution



This integrated circuit can be damaged by ESD. Texas Instruments recommends that all integrated circuits be handled with appropriate precautions. Failure to observe proper handling and installation procedures can cause damage.

ESD damage can range from subtle performance degradation to complete device failure. Precision integrated circuits may be more susceptible to damage because very small parametric changes could cause the device not to meet its published specifications.

10.6 Glossary

[TI Glossary](#) This glossary lists and explains terms, acronyms, and definitions.

11 Mechanical, Packaging, and Orderable Information

The following pages include mechanical, packaging, and orderable information. This information is the most current data available for the designated devices. This data is subject to change without notice and revision of this document. For browser-based versions of this data sheet, refer to the left-hand navigation.

PACKAGING INFORMATION

Orderable Device	Status (1)	Package Type	Package Drawing	Pins	Package Qty	Eco Plan (2)	Lead finish/ Ball material (6)	MSL Peak Temp (3)	Op Temp (°C)	Device Marking (4/5)	Samples
5962-9052401MEA	ACTIVE	CDIP	J	16	1	Non-RoHS & Green	SNPB	N / A for Pkg Type	-55 to 125	5962-9052401ME A CD54HCT251F3A	Samples
CD54HC251F	ACTIVE	CDIP	J	16	1	Non-RoHS & Green	SNPB	N / A for Pkg Type	-55 to 125	CD54HC251F	Samples
CD54HC251F3A	ACTIVE	CDIP	J	16	1	Non-RoHS & Green	SNPB	N / A for Pkg Type	-55 to 125	8512501EA CD54HC251F3A	Samples
CD54HCT251F3A	ACTIVE	CDIP	J	16	1	Non-RoHS & Green	SNPB	N / A for Pkg Type	-55 to 125	5962-9052401ME A CD54HCT251F3A	Samples
CD74HC251E	ACTIVE	PDIP	N	16	25	RoHS & Green	NIPDAU	N / A for Pkg Type	-55 to 125	CD74HC251E	Samples
CD74HC251EE4	ACTIVE	PDIP	N	16	25	RoHS & Green	NIPDAU	N / A for Pkg Type	-55 to 125	CD74HC251E	Samples
CD74HC251M	ACTIVE	SOIC	D	16	40	RoHS & Green	NIPDAU	Level-1-260C-UNLIM	-55 to 125	HC251M	Samples
CD74HC251M96	ACTIVE	SOIC	D	16	2500	RoHS & Green	NIPDAU	Level-1-260C-UNLIM	-55 to 125	HC251M	Samples
CD74HC251MT	ACTIVE	SOIC	D	16	250	RoHS & Green	NIPDAU	Level-1-260C-UNLIM	-55 to 125	HC251M	Samples
CD74HCT251E	ACTIVE	PDIP	N	16	25	RoHS & Green	NIPDAU	N / A for Pkg Type	-55 to 125	CD74HCT251E	Samples
CD74HCT251M	ACTIVE	SOIC	D	16	40	RoHS & Green	NIPDAU	Level-1-260C-UNLIM	-55 to 125	HCT251M	Samples
CD74HCT251M96	ACTIVE	SOIC	D	16	2500	RoHS & Green	NIPDAU	Level-1-260C-UNLIM	-55 to 125	HCT251M	Samples
CD74HCT251ME4	ACTIVE	SOIC	D	16	40	RoHS & Green	NIPDAU	Level-1-260C-UNLIM	-55 to 125	HCT251M	Samples
CD74HCT251MT	ACTIVE	SOIC	D	16	250	RoHS & Green	NIPDAU	Level-1-260C-UNLIM	-55 to 125	HCT251M	Samples

(1) The marketing status values are defined as follows:

ACTIVE: Product device recommended for new designs.

LIFEBUY: TI has announced that the device will be discontinued, and a lifetime-buy period is in effect.

NRND: Not recommended for new designs. Device is in production to support existing customers, but TI does not recommend using this part in a new design.

PREVIEW: Device has been announced but is not in production. Samples may or may not be available.

OBSOLETE: TI has discontinued the production of the device.

(2) **RoHS:** TI defines "RoHS" to mean semiconductor products that are compliant with the current EU RoHS requirements for all 10 RoHS substances, including the requirement that RoHS substance do not exceed 0.1% by weight in homogeneous materials. Where designed to be soldered at high temperatures, "RoHS" products are suitable for use in specified lead-free processes. TI may reference these types of products as "Pb-Free".

RoHS Exempt: TI defines "RoHS Exempt" to mean products that contain lead but are compliant with EU RoHS pursuant to a specific EU RoHS exemption.

Green: TI defines "Green" to mean the content of Chlorine (Cl) and Bromine (Br) based flame retardants meet JS709B low halogen requirements of ≤ 1000 ppm threshold. Antimony trioxide based flame retardants must also meet the ≤ 1000 ppm threshold requirement.

(3) MSL, Peak Temp. - The Moisture Sensitivity Level rating according to the JEDEC industry standard classifications, and peak solder temperature.

(4) There may be additional marking, which relates to the logo, the lot trace code information, or the environmental category on the device.

(5) Multiple Device Markings will be inside parentheses. Only one Device Marking contained in parentheses and separated by a "~" will appear on a device. If a line is indented then it is a continuation of the previous line and the two combined represent the entire Device Marking for that device.

(6) Lead finish/Ball material - Orderable Devices may have multiple material finish options. Finish options are separated by a vertical ruled line. Lead finish/Ball material values may wrap to two lines if the finish value exceeds the maximum column width.

Important Information and Disclaimer: The information provided on this page represents TI's knowledge and belief as of the date that it is provided. TI bases its knowledge and belief on information provided by third parties, and makes no representation or warranty as to the accuracy of such information. Efforts are underway to better integrate information from third parties. TI has taken and continues to take reasonable steps to provide representative and accurate information but may not have conducted destructive testing or chemical analysis on incoming materials and chemicals. TI and TI suppliers consider certain information to be proprietary, and thus CAS numbers and other limited information may not be available for release.

In no event shall TI's liability arising out of such information exceed the total purchase price of the TI part(s) at issue in this document sold by TI to Customer on an annual basis.

OTHER QUALIFIED VERSIONS OF CD54HC251, CD54HCT251, CD74HC251, CD74HCT251 :

● Catalog : [CD74HC251](#), [CD74HCT251](#)

● Military : [CD54HC251](#), [CD54HCT251](#)

NOTE: Qualified Version Definitions:

● Catalog - TI's standard catalog product

● Military - QML certified for Military and Defense Applications

TAPE AND REEL INFORMATION

QUADRANT ASSIGNMENTS FOR PIN 1 ORIENTATION IN TAPE



*All dimensions are nominal

Device	Package Type	Package Drawing	Pins	SPQ	Reel Diameter (mm)	Reel Width W1 (mm)	A0 (mm)	B0 (mm)	K0 (mm)	P1 (mm)	W (mm)	Pin1 Quadrant
CD74HC251M96	SOIC	D	16	2500	330.0	16.4	6.5	10.3	2.1	8.0	16.0	Q1
CD74HCT251M96	SOIC	D	16	2500	330.0	16.4	6.5	10.3	2.1	8.0	16.0	Q1

TAPE AND REEL BOX DIMENSIONS

*All dimensions are nominal

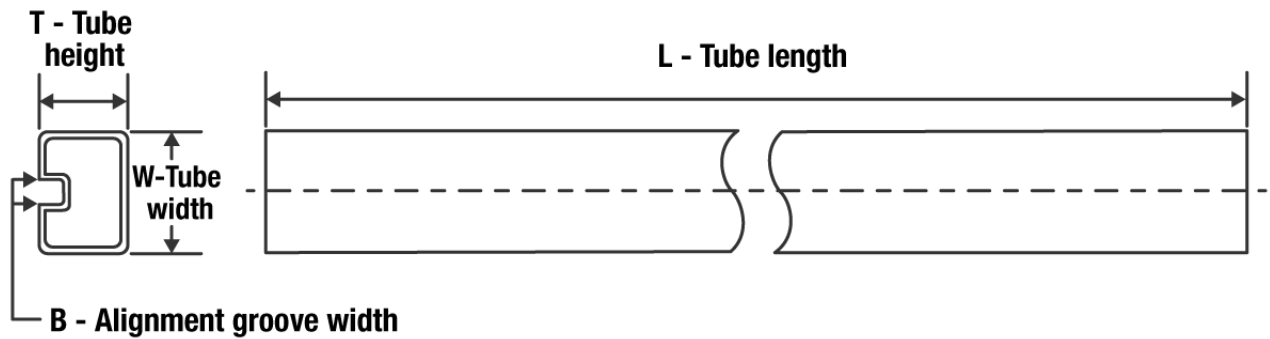
Device	Package Type	Package Drawing	Pins	SPQ	Length (mm)	Width (mm)	Height (mm)
CD74HC251M96	SOIC	D	16	2500	340.5	336.1	32.0
CD74HCT251M96	SOIC	D	16	2500	340.5	336.1	32.0

TUBE

*All dimensions are nominal

Device	Package Name	Package Type	Pins	SPQ	L (mm)	W (mm)	T (μm)	B (mm)
CD74HC251E	N	PDIP	16	25	506	13.97	11230	4.32
CD74HC251E	N	PDIP	16	25	506	13.97	11230	4.32
CD74HC251EE4	N	PDIP	16	25	506	13.97	11230	4.32
CD74HC251EE4	N	PDIP	16	25	506	13.97	11230	4.32
CD74HC251M	D	SOIC	16	40	507	8	3940	4.32
CD74HCT251E	N	PDIP	16	25	506	13.97	11230	4.32
CD74HCT251E	N	PDIP	16	25	506	13.97	11230	4.32
CD74HCT251M	D	SOIC	16	40	507	8	3940	4.32
CD74HCT251ME4	D	SOIC	16	40	507	8	3940	4.32

D (R-PDSO-G16)

PLASTIC SMALL OUTLINE



- NOTES:
- A. All linear dimensions are in inches (millimeters).
 - B. This drawing is subject to change without notice.
 - C. Body length does not include mold flash, protrusions, or gate burrs. Mold flash, protrusions, or gate burrs shall not exceed 0.006 (0,15) each side.
 - D. Body width does not include interlead flash. Interlead flash shall not exceed 0.017 (0,43) each side.
 - E. Reference JEDEC MS-012 variation AC.

D (R-PDSO-G16)

PLASTIC SMALL OUTLINE



- NOTES:
- All linear dimensions are in millimeters.
 - This drawing is subject to change without notice.
 - Publication IPC-7351 is recommended for alternate designs.
 - Laser cutting apertures with trapezoidal walls and also rounding corners will offer better paste release. Customers should contact their board assembly site for stencil design recommendations. Refer to IPC-7525 for other stencil recommendations.
 - Customers should contact their board fabrication site for solder mask tolerances between and around signal pads.

J (R-GDIP-T**)

14 LEADS SHOWN

CERAMIC DUAL IN-LINE PACKAGE



DIM \ PINS **	14	16	18	20
A	0.300 (7,62) BSC	0.300 (7,62) BSC	0.300 (7,62) BSC	0.300 (7,62) BSC
B MAX	0.785 (19,94)	.840 (21,34)	0.960 (24,38)	1.060 (26,92)
B MIN	—	—	—	—
C MAX	0.300 (7,62)	0.300 (7,62)	0.310 (7,87)	0.300 (7,62)
C MIN	0.245 (6,22)	0.245 (6,22)	0.220 (5,59)	0.245 (6,22)



4040083/F 03/03

- NOTES:
- All linear dimensions are in inches (millimeters).
 - This drawing is subject to change without notice.
 - This package is hermetically sealed with a ceramic lid using glass frit.
 - Index point is provided on cap for terminal identification only on press ceramic glass frit seal only.
 - Falls within MIL STD 1835 GDIP1-T14, GDIP1-T16, GDIP1-T18 and GDIP1-T20.

N (R-PDIP-T**)

PLASTIC DUAL-IN-LINE PACKAGE

16 PINS SHOWN



- NOTES:
- A. All linear dimensions are in inches (millimeters).
 - B. This drawing is subject to change without notice.
 - $\triangle C$ Falls within JEDEC MS-001, except 18 and 20 pin minimum body length (Dim A).
 - $\triangle D$ The 20 pin end lead shoulder width is a vendor option, either half or full width.

4040049/E 12/2002

IMPORTANT NOTICE AND DISCLAIMER

TI PROVIDES TECHNICAL AND RELIABILITY DATA (INCLUDING DATA SHEETS), DESIGN RESOURCES (INCLUDING REFERENCE DESIGNS), APPLICATION OR OTHER DESIGN ADVICE, WEB TOOLS, SAFETY INFORMATION, AND OTHER RESOURCES "AS IS" AND WITH ALL FAULTS, AND DISCLAIMS ALL WARRANTIES, EXPRESS AND IMPLIED, INCLUDING WITHOUT LIMITATION ANY IMPLIED WARRANTIES OF MERCHANTABILITY, FITNESS FOR A PARTICULAR PURPOSE OR NON-INFRINGEMENT OF THIRD PARTY INTELLECTUAL PROPERTY RIGHTS.

These resources are intended for skilled developers designing with TI products. You are solely responsible for (1) selecting the appropriate TI products for your application, (2) designing, validating and testing your application, and (3) ensuring your application meets applicable standards, and any other safety, security, regulatory or other requirements.

These resources are subject to change without notice. TI grants you permission to use these resources only for development of an application that uses the TI products described in the resource. Other reproduction and display of these resources is prohibited. No license is granted to any other TI intellectual property right or to any third party intellectual property right. TI disclaims responsibility for, and you will fully indemnify TI and its representatives against, any claims, damages, costs, losses, and liabilities arising out of your use of these resources.

TI's products are provided subject to [TI's Terms of Sale](#) or other applicable terms available either on ti.com or provided in conjunction with such TI products. TI's provision of these resources does not expand or otherwise alter TI's applicable warranties or warranty disclaimers for TI products.

TI objects to and rejects any additional or different terms you may have proposed.

Mailing Address: Texas Instruments, Post Office Box 655303, Dallas, Texas 75265
Copyright © 2022, Texas Instruments Incorporated