



## Dual, Wideband, High Output Current, Operational Amplifier with Current Limit

### FEATURES

- **LOW INPUT NOISE VOLTAGE:**  $1.8\text{nV}/\sqrt{\text{Hz}}$
- **HIGH UNITY-GAIN BANDWIDTH:** 230MHz
- **HIGH GAIN BANDWIDTH PRODUCT:** 125MHz
- **HIGH OUTPUT CURRENT:** 350mA
- **LOW INPUT OFFSET VOLTAGE:**  $\pm 0.2\text{mV}$
- **FLEXIBLE SUPPLY RANGE:**  
Single +5V to +12V Operation  
Dual  $\pm 2.5\text{V}$  to  $\pm 6\text{V}$  Operation
- **LOW SUPPLY CURRENT:** 6.0mA/ch

### DESCRIPTION

The OPA2613 offers very low  $1.8\text{nV}/\sqrt{\text{Hz}}$  input noise in a wideband, unity-gain stable, voltage-feedback architecture. Intended for xDSL driver applications, the OPA2613 also supports this low input noise with exceptionally low harmonic distortion, particularly in differential configurations. Adequate output current is provided to drive the potentially heavy load of a twisted-pair line. Harmonic distortion for a  $2\text{V}_{\text{PP}}$  differential output operating from +5V to +12V supplies is  $\leq -95\text{dBc}$  through 1MHz input frequencies. Operating on a low 6.0mA/ch supply current, the OPA2613 can satisfy most xDSL driver requirements over a wide range of possible supply voltage—from a single +5V condition, to  $\pm 5\text{V}$ , on up to a single +12V design.

General-purpose applications on a single +5V supply will benefit from the high input and output voltage swing available on this reduced supply voltage. Low-cost precision integrators for PLLs will also benefit from the low voltage noise and offset voltage. Baseband I/Q receiver channels can achieve almost perfect channel match with noise and distortion to support signals through 5MHz with > 14-bit dynamic range.

### APPLICATIONS

- xDSL DIFFERENTIAL LINE DRIVERS
- 16-BIT ADC DRIVER
- LOW NOISE PLL INTEGRATORS
- TRANSIMPEDANCE AMPLIFIERS
- PRECISION BASEBAND I/Q AMPLIFIERS
- ACTIVE FILTERS
- TS613 IMPROVED REPLACEMENT

### OPA2613 RELATED PRODUCTS

FEATURES	SINGLES	DUALS	TRIPLES
High Gain Stable	—	OPA2614	—
High Slew Rate VFB	OPA690	OPA2690	OPA3690
R/R Input/Output VFB	OPA353	OPA2353	—
Current-Feedback	OPA691	OPA2691	OPA3691
Current-Feedback	—	OPA2677	—

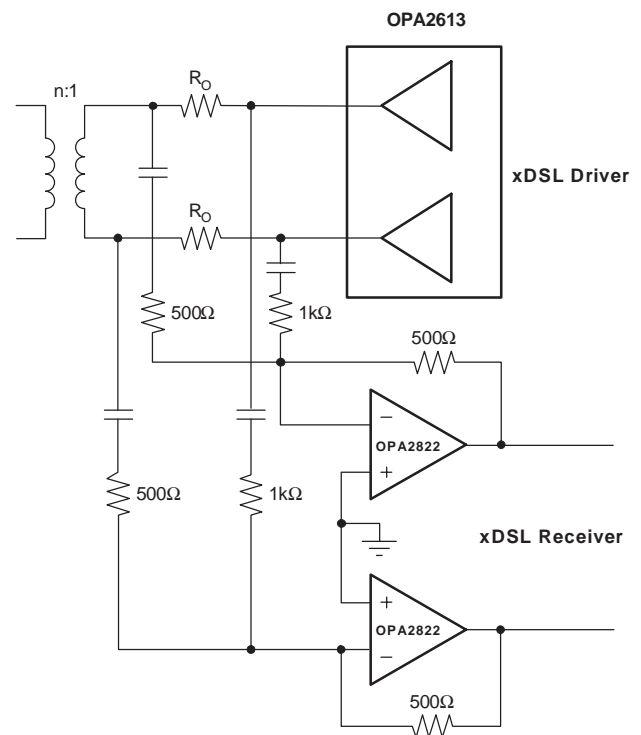

Please be aware that an important notice concerning availability, standard warranty, and use in critical applications of Texas Instruments semiconductor products and disclaimers thereto appears at the end of this data sheet.

All trademarks are the property of their respective owners.

**ABSOLUTE MAXIMUM RATINGS(1)**

Supply Voltage (–40°C to +85°C)	±6.5V
Supply Voltage (0°C to +70°C)	±6.65V
Internal Power Dissipation	See Thermal Characteristics
Differential Input Voltage	±1.2V
Input Voltage Range	±V <sub>S</sub>
Storage Temperature Range	–65°C to +125°C
Lead Temperature (SO-8)	+260°C
Junction Temperature (T <sub>J</sub> )	+150°C
ESD Rating (Human Body Model)	2000V
(Machine Model)	200V
(Charge Device Model)	1500V

(1) Stresses above these ratings may cause permanent damage. Exposure to absolute maximum conditions for extended periods may degrade device reliability. These are stress ratings only, and functional operation of the device at these or any other conditions beyond those specified is not supported.



**ELECTROSTATIC DISCHARGE SENSITIVITY**

This integrated circuit can be damaged by ESD. Texas Instruments recommends that all integrated circuits be handled with appropriate precautions. Failure to observe proper handling and installation procedures can cause damage.

ESD damage can range from subtle performance degradation to complete device failure. Precision integrated circuits may be more susceptible to damage because very small parametric changes could cause the device not to meet its published specifications.

**PACKAGE/ORDERING INFORMATION(1)**

PRODUCT	PACKAGE-LEAD	PACKAGE DESIGNATOR	SPECIFIED TEMPERATURE RANGE	PACKAGE MARKING	ORDERING NUMBER	TRANSPORT MEDIA, QUANTITY
OPA2613	SO-8	D	–40°C to +85°C	OPA2613	OPA2613ID OPA2613IDR	Rails, 100 Tape and Reel, 2500

(1) For the most current package and ordering information see the Package Option Addendum at the end of this document, or see the TI web site at [www.ti.com](http://www.ti.com).

**PIN CONFIGURATION**

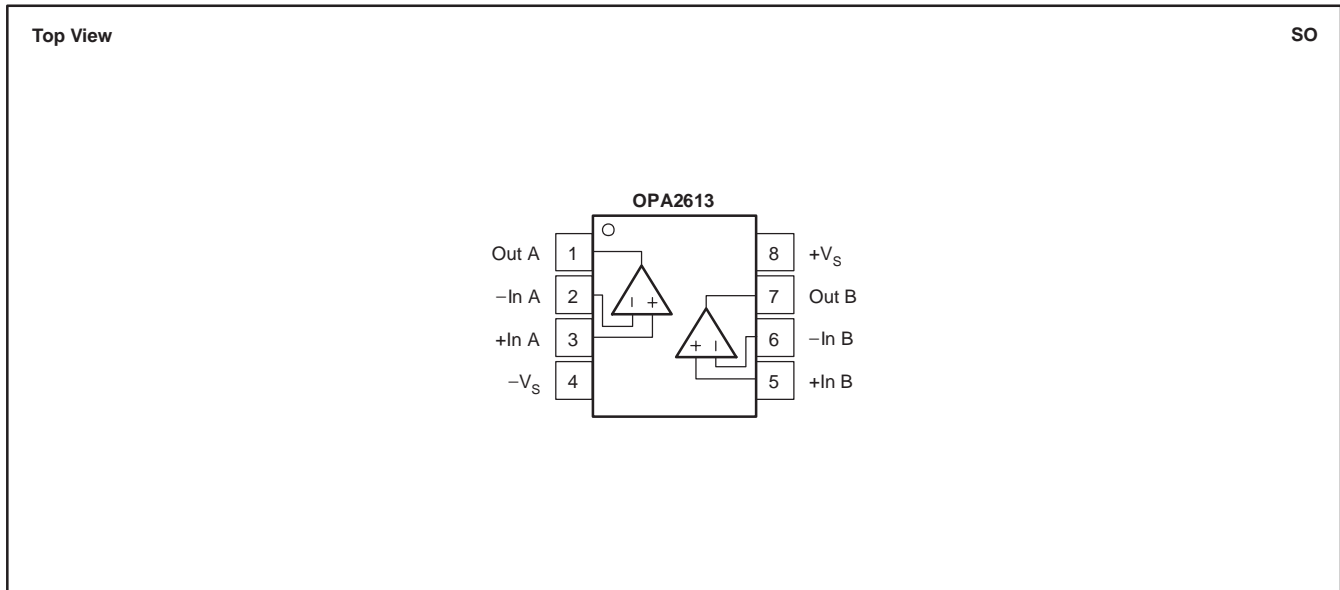

**ELECTRICAL CHARACTERISTICS:  $V_S = \pm 6V$**

**Boldface** limits are tested at **+25°C**.

$R_F = 402\Omega$ ,  $R_L = 100\Omega$ , and  $G = +2$ , unless otherwise noted. See Figure 1 for AC performance only.

PARAMETER	TEST CONDITIONS	OPA2613ID						TEST LEVEL (3)	
		TYP	MIN/MAX OVER TEMPERATURE				UNITS		MIN/MAX
		+25°C	+25°C(1)	0°C to +70°C(2)	-40°C to +85°C(2)				
<b>AC Performance (see Figure 1)</b>									
Small-Signal Bandwidth	$G = +1, V_O = 0.1V_{PP}, R_F = 0\Omega$	230				MHz	typ	C	
	$G = +2, V_O = 0.1V_{PP}$	110	80	75	70	MHz	min	B	
	$G = +10, V_O = 0.1V_{PP}$	13	10	9	9	MHz	min	B	
Gain-Bandwidth Product	$G \geq 20$	125	95	80	75	MHz	min	B	
Bandwidth for 0.1dB Gain Flatness	$G = +2, V_O < 0.1V_{PP}$	5				MHz	typ	C	
Peaking at a Gain of +1	$V_O < 0.1V_{PP}$	1				dB	typ	C	
Large-Signal Bandwidth	$G = +2, V_O = 2V_{PP}$	22				MHz	typ	C	
Slew Rate	$G = +2, 4V$ Step	70	56	51	50	V/ $\mu$ s	min	B	
Rise-and-Fall Time	$G = +2, V_O = 0.2V$ Step	3.6	4.8	5.4	5.5	ns	typ	C	
Settling Time to 0.02%	$G = +2, V_O = 2V$ Step	55	68	71	72	ns	typ	C	
0.1%	$G = +2, V_O = 2V$ Step	40	51	53	54	ns	typ	C	
Harmonic Distortion	$G = +2, f = 1MHz, V_O = 2V_{PP}$								
2nd-Harmonic	$R_L = 20\Omega$	-70	-63	-61	-60	dBc	max	B	
	$R_L \geq 500\Omega$	-95	-90	-88	-87	dBc	max	B	
3rd-Harmonic	$R_L = 20\Omega$	-84	-80	-78	-77	dBc	max	B	
	$R_L \geq 500\Omega$	-97	-92	-90	-89	dBc	max	B	
Input Voltage Noise	$f > 10kHz$	1.8	2.0	2.1	2.3	nV/ $\sqrt{Hz}$	max	B	
Input Current Noise	$f > 10kHz$	1.7	2.1	2.2	2.4	pA/ $\sqrt{Hz}$	max	B	
Differential Gain	$G = +2, PAL, V_O = 1.4V_{PP}, R_L = 150\Omega$	0.02				%	typ	C	
Differential Phase	$G = +2, PAL, V_O = 1.4V_{PP}, R_L = 150\Omega$	0.03				deg	typ	C	
Channel-to-Channel Crosstalk	$f = 1MHz, Input-Referred$	-80				dBc	typ	C	
<b>DC Performance(4)</b>									
Open-Loop Gain ( $A_{OL}$ )	$V_O = 0V, R_L = 100\Omega$	97	<b>92</b>	92	91	dB	min	A	
Input Offset Voltage	$V_{CM} = 0V$	$\pm 0.2$	<b><math>\pm 1.0</math></b>	$\pm 1.15$	$\pm 1.2$	mV	max	A	
Average Offset Voltage Drift	$V_{CM} = 0V$			$\pm 3.3$	$\pm 3.3$	$\mu V/^\circ C$	max	B	
Input Bias Current	$V_{CM} = 0V$	-6	<b>-12</b>	-13	-14.5	$\mu A$	max	A	
Average Bias Current Drift (Magnitude)	$V_{CM} = 0V$			-30	-35	nA/ $^\circ C$	max	B	
Input Offset Current	$V_{CM} = 0V$	$\pm 50$	<b><math>\pm 300</math></b>	$\pm 520$	$\pm 750$	nA	max	A	
Average Offset Bias Current Drift	$V_{CM} = 0V$			$\pm 5$	$\pm 7$	nA/ $^\circ C$	max	B	
<b>Input</b>									
Common-Mode Input Range (CMIR)(5)		$\pm 4.7$	<b><math>\pm 4.5</math></b>	$\pm 4.5$	$\pm 4.4$	V	min	A	
Common-Mode Rejection Ratio (CMRR)	$V_{CM} = \pm 1V$	100	<b>88</b>	87	86	dB	min	A	
Input Impedance									
Differential-Mode	$V_{CM} = 0$	18    0.6				k $\Omega$    pF	typ	C	
Common-Mode	$V_{CM} = 0$	7    1				M $\Omega$    pF	typ	C	
<b>Output</b>									
Output Voltage Swing	No Load	$\pm 5.0$	<b><math>\pm 4.8</math></b>	$\pm 4.8$	$\pm 4.7$	V	min	A	
	100 $\Omega$	$\pm 4.9$	<b><math>\pm 4.7</math></b>	$\pm 4.7$	$\pm 4.6$	V	min	A	
Current Output, Sourcing	$V_O = 0, Linear Operation$	+350	<b>+280</b>	+240	+220	mA	min	A	
Current Output, Sinking	$V_O = 0, Linear Operation$	-350	<b>-280</b>	-240	-220	mA	min	A	
Short-Circuit Current	Output Shorted to Ground	500				mA	typ	C	
Closed-Loop Output Impedance	$G = +2, f = 100kHz$	0.01				$\Omega$	typ	C	

(1) Junction temperature = ambient for +25°C tested specifications.

(2) Junction temperature = ambient at low temperature limit; junction temperature = ambient +23°C at high temperature limit for over temperature tested specifications.

(3) Test levels: (A) 100% tested at +25°C. Over temperature limits by characterization and simulation. (B) Limits set by characterization and simulation. (C) Typical value only for information.

(4) Current is considered positive-out-of-node.  $V_{CM}$  is the input common-mode voltage.

(5) Tested < 3dB below minimum CMRR specification at  $\pm$  CMIR limits.

**ELECTRICAL CHARACTERISTICS:  $V_S = \pm 6V$  (continued)****Boldface** limits are tested at **+25°C**. $R_F = 402\Omega$ ,  $R_L = 100\Omega$ , and  $G = +2$ , unless otherwise noted. See Figure 1 for AC performance only.

PARAMETER	TEST CONDITIONS	OPA2613ID						TEST LEVEL (3)
		TYP	MIN/MAX OVER TEMPERATURE				MIN/MAX	
		+25°C	+25°C(1)	0°C to +70°C(2)	-40°C to +85°C(2)	UNITS		
<b>Power Supply</b>								
Specified Operating Voltage		$\pm 6$				V	typ	C
Maximum Operating Voltage Range			<b><math>\pm 6.3</math></b>	$\pm 6.3$	$\pm 6.3$	V	max	A
Maximum Quiescent Current	$V_S = \pm 6V$ , Both Channels	12	<b>12.4</b>	12.8	13	mA	max	A
Minimum Quiescent Current	$V_S = \pm 6V$ , Both Channels	12	<b>11.6</b>	11.2	11	mA	min	A
Power-Supply Rejection Ratio (-PSRR)	Input-Referred	95	<b>90</b>	88	87	dB	min	A
<b>Thermal Characteristics</b>								
Specified Operating Range D Package		-40 to +85				°C	typ	C
Thermal Resistance, $\theta_{JA}$	Junction-to-Ambient							
D SO-8		125				°C/W	typ	C

(1) Junction temperature = ambient for +25°C tested specifications.

(2) Junction temperature = ambient at low temperature limit; junction temperature = ambient +23°C at high temperature limit for over temperature tested specifications.

(3) Test levels: (A) 100% tested at +25°C. Over temperature limits by characterization and simulation. (B) Limits set by characterization and simulation. (C) Typical value only for information.

(4) Current is considered positive-out-of-node.  $V_{CM}$  is the input common-mode voltage.(5) Tested < 3dB below minimum CMRR specification at  $\pm$  CMIR limits.

**ELECTRICAL CHARACTERISTICS:  $V_S = +5V$**

**Boldface limits are tested at +25°C.**

$R_F = 402\Omega$ ,  $R_L = 100\Omega$ , and  $G = +2$ , unless otherwise noted. See Figure 3 for AC performance only.

PARAMETER	TEST CONDITIONS	OPA2613ID						TEST LEVEL (3)
		TYP	MIN/MAX OVER TEMPERATURE				MIN/MAX	
		+25°C	+25°C(1)	0°C to +70°C(2)	-40°C to +85°C(2)	UNITS		
<b>AC Performance (see Figure 3)</b>								
Small-Signal Bandwidth	$G = +1, V_O = 0.1V_{PP}, R_F = 0\Omega$	230				MHz	typ	C
	$G = +2, V_O = 0.1V_{PP}$	105	75	69	68	MHz	min	B
	$G = +10, V_O = 0.1V_{PP}$	12	10	8	8	MHz	min	B
Gain-Bandwidth Product	$G \geq 20$	118	93	78	76	MHz	min	B
Bandwidth for 0.1dB Gain Flatness	$G = +2, V_O < 0.1V_{PP}$	5				MHz	typ	C
Peaking at a Gain of +1	$V_O < 0.1V_{PP}$	2.6				dB	typ	C
Large-Signal Bandwidth	$G = +2, V_O = 2V_{PP}$	21				MHz	typ	C
Slew Rate	$G = +2, 2V$ Step	60	47	46	46	V/ $\mu$ s	min	B
Rise-and-Fall Time	$G = +2, V_O = 0.2V$ Step	3.8	5.0	5.6	5.7	ns	typ	B
Settling Time to 0.02%	$G = +2, V_O = 2V$ Step	63	78	80	81	ns	typ	B
0.1%	$G = +2, V_O = 2V$ Step	52	62	64	64	ns	typ	B
Harmonic Distortion	$G = +2, f = 1MHz, V_O = 2V_{PP}$							
2nd-Harmonic	$R_L = 20\Omega$ to $V_S/2$	-67	-60	-58	-57	dBc	max	B
	$R_L \geq 500\Omega$ to $V_S/2$	-82	-79	-77	-76	dBc	max	B
3rd-Harmonic	$R_L = 20\Omega$ to $V_S/2$	-84	-78	-76	-75	dBc	max	B
	$R_L \geq 500\Omega$ to $V_S/2$	-94	-89	-87	-86	dBc	max	B
Input Voltage Noise	$f > 10kHz$	1.9	2.1	2.2	2.4	nV/ $\sqrt{Hz}$	max	B
Input Current Noise	$f > 10kHz$	1.7	2.1	2.2	2.4	pA/ $\sqrt{Hz}$	max	B
Channel-to-Channel Crosstalk	$f = 1MHz, Input-Referred$	-80				dBc	typ	C
<b>DC Performance(4)</b>								
Open-Loop Gain ( $A_{OL}$ )	$V_O = 0V, R_L = 100\Omega$	95	<b>91</b>	89	88	dB	min	A
Input Offset Voltage	$V_{CM} = 0V$	$\pm 0.2$	<b><math>\pm 1.0</math></b>	$\pm 1.15$	$\pm 1.2$	mV	max	A
Average Offset Voltage Drift	$V_{CM} = 0V$			$\pm 3.3$	$\pm 3.3$	$\mu V/^\circ C$	max	B
Input Bias Current	$V_{CM} = 0V$	-6	<b>-11</b>	-12	-13.5	$\mu A$	max	A
Average Bias Current Drift (Magnitude)	$V_{CM} = 0V$			-35	-35	nA/ $^\circ C$	max	B
Input Offset Current	$V_{CM} = 0V$	$\pm 50$	<b><math>\pm 300</math></b>	$\pm 520$	$\pm 750$	nA	max	A
Average Offset Bias Current Drift	$V_{CM} = 0V$			$\pm 5$	$\pm 7$	nA/ $^\circ C$	max	B
<b>Input</b>								
Least Positive Input Voltage		1.2	<b>1.4</b>	1.4	1.5	V	max	A
Most Positive Input Voltage		3.8	<b>3.6</b>	3.6	3.5	V	min	A
Common-Mode Rejection Ratio (CMRR)	$V_{CM} = \pm 1V$	95	<b>85</b>	84	83	dB	min	A
Input Impedance								A
Differential-Mode	$V_{CM} = 0$	15    1				k $\Omega$    pF	typ	C
Common-Mode	$V_{CM} = 0$	5    1.3				M $\Omega$    pF	typ	C
<b>Output</b>								
Most Positive Output Voltage	No Load	4.0	<b>3.85</b>	3.8	3.75	V	min	A
	100 $\Omega$ Load to 2.5V	3.95	<b>3.8</b>	3.75	3.7	V	min	A
Least Positive Output Voltage	No Load	1.0	<b>1.15</b>	1.2	1.25	V	min	A
	100 $\Omega$ Load to 2.5V	1.05	<b>1.20</b>	1.25	1.3	V	min	A
Current Output, Sourcing	$V_O = 0, Linear Operation$	+300				mA	typ	C
Current Output, Sinking	$V_O = 0, Linear Operation$	-300				mA	typ	C
Short-Circuit Current	Output Shorted to Mid-Supply	$\pm 400$				mA	typ	C
Closed-Loop Output Impedance	$G = +2, f = 100kHz$	0.01				$\Omega$	typ	C

(1) Junction temperature = ambient for +25°C tested specifications.

(2) Junction temperature = ambient at low temperature limit; junction temperature = ambient +23°C at high temperature limit for over temperature tested specifications.

(3) Test levels: (A) 100% tested at +25°C. Over temperature limits by characterization and simulation. (B) Limits set by characterization and simulation. (C) Typical value only for information.

(4) Current is considered positive-out-of-node.  $V_{CM}$  is the input common-mode voltage.

(5) Tested < 3dB below minimum CMRR specification at  $\pm$  CMIR limits.

**ELECTRICAL CHARACTERISTICS:  $V_S = +5V$  (continued)****Boldface** limits are tested at **+25°C**. $R_F = 402\Omega$ ,  $R_L = 100\Omega$ , and  $G = +2$ , unless otherwise noted. See Figure 3 for AC performance only.

PARAMETER	TEST CONDITIONS	OPA2613ID						TEST LEVEL (3)
		TYP	MIN/MAX OVER TEMPERATURE				MIN/ MAX	
		+25°C	+25°C(1)	0°C to +70°C(2)	-40°C to +85°C(2)	UNITS		
<b>Power Supply</b>								
Specified Operating Voltage		5				V	typ	C
Maximum Operating Voltage Range			<b>12.6</b>	12.6	12.6	V	max	A
Maximum Quiescent Current	$V_S = \pm 6V$ , Both Channels	10.5	<b>11.0</b>	11.3	11.5	mA	max	A
Minimum Quiescent Current	$V_S = \pm 6V$ , Both Channels	10.5	<b>9.4</b>	9.4	9.1	mA	min	A
Power-Supply Rejection Ratio (-PSRR)	Input-Referred	95				dB	typ	C
<b>Thermal Characteristics</b>								
Specified Operating Range D Package		-40 to +85				°C	typ	C
Thermal Resistance, $\theta_{JA}$ D SO-8	Junction-to-Ambient	125				°C/W	typ	C

(1) Junction temperature = ambient for +25°C tested specifications.

(2) Junction temperature = ambient at low temperature limit; junction temperature = ambient +23°C at high temperature limit for over temperature tested specifications.

(3) Test levels: (A) 100% tested at +25°C. Over temperature limits by characterization and simulation. (B) Limits set by characterization and simulation. (C) Typical value only for information.

(4) Current is considered positive-out-of-node.  $V_{CM}$  is the input common-mode voltage.(5) Tested < 3dB below minimum CMRR specification at  $\pm$  CMIR limits.

**TYPICAL CHARACTERISTICS:  $V_S = \pm 6V$**

At  $T_A = +25^\circ C$ ,  $G = +2$ ,  $R_F = 402\Omega$ , and  $R_L = 100\Omega$ , unless otherwise noted.

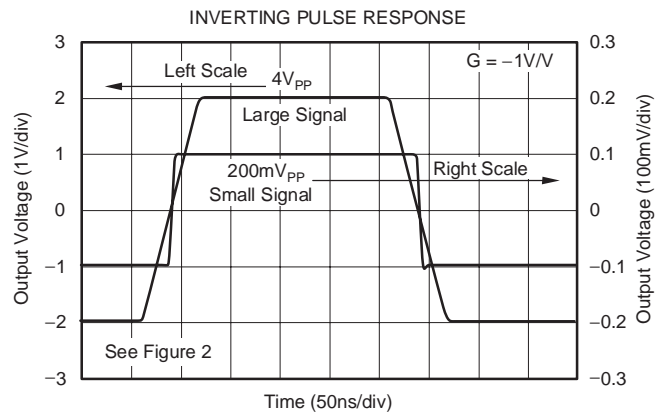
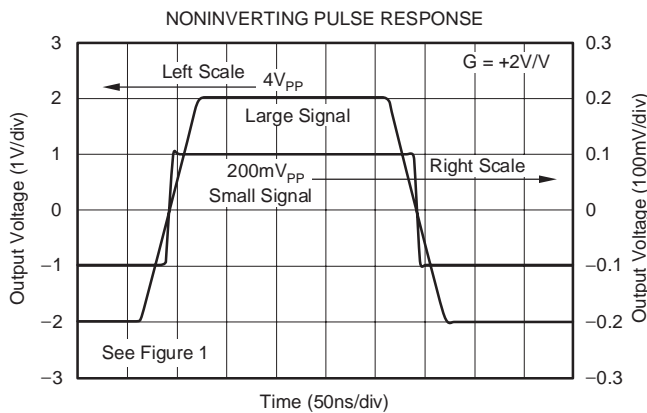
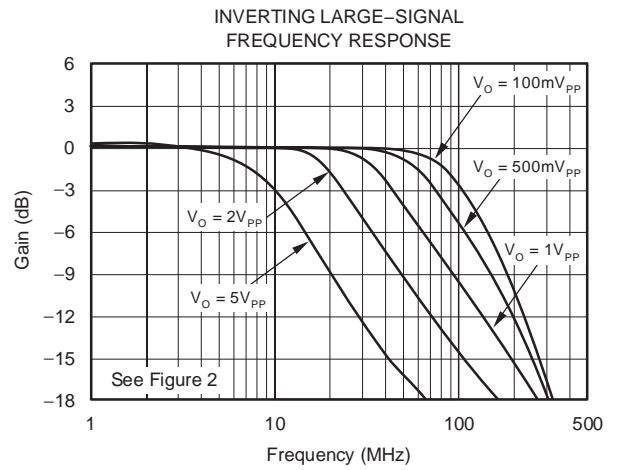
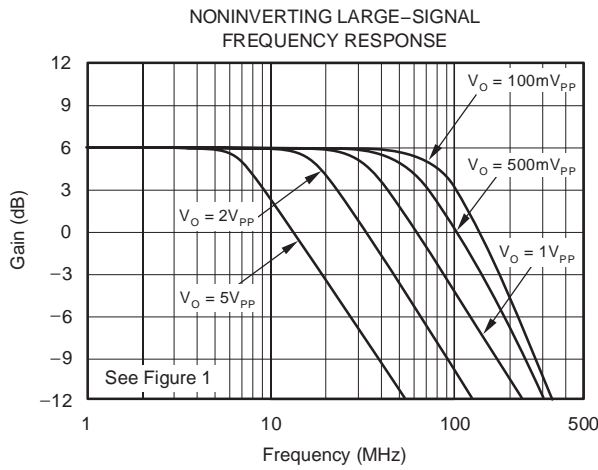
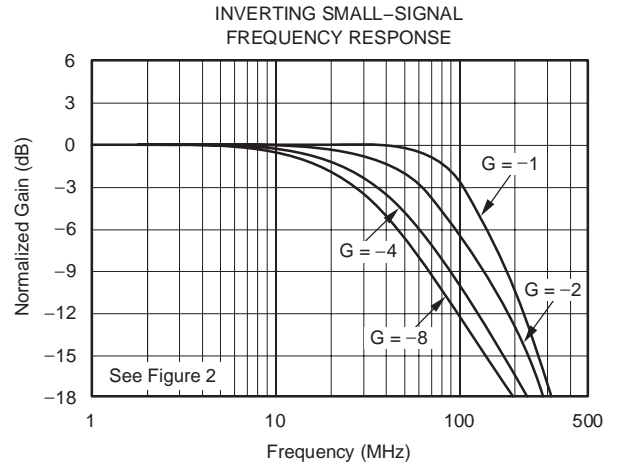
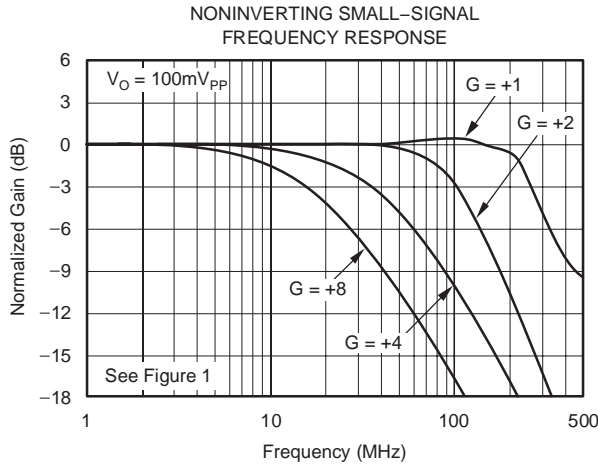

**TYPICAL CHARACTERISTICS:  $V_S = \pm 6V$  (continued)**

At  $T_A = +25^\circ C$ ,  $G = +2$ ,  $R_F = 402\Omega$ , and  $R_L = 100\Omega$ , unless otherwise noted.

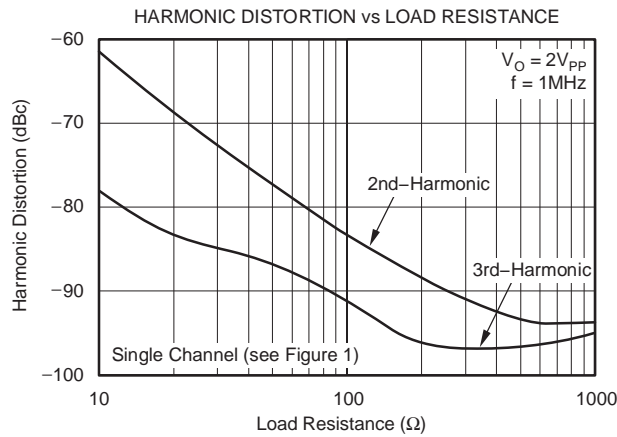
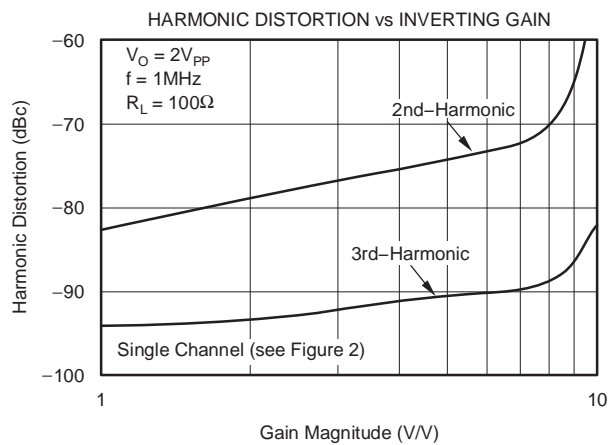
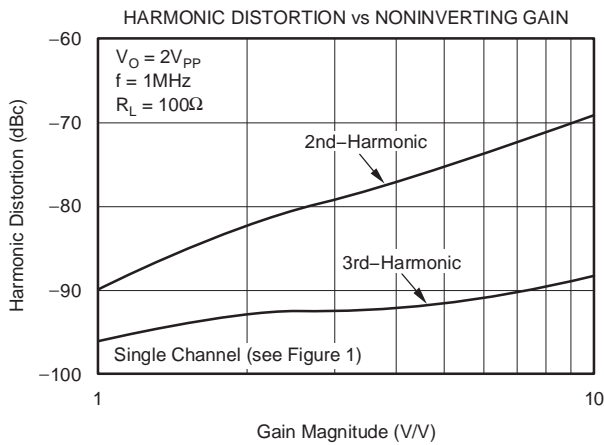
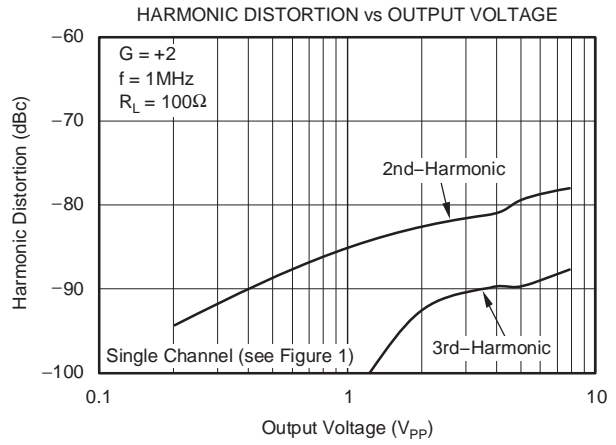
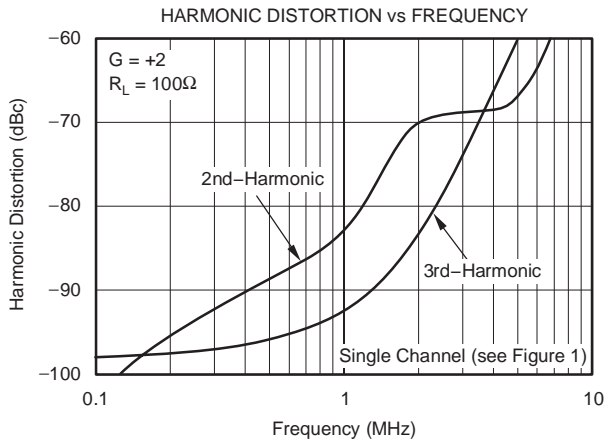

**TYPICAL CHARACTERISTICS:  $V_S = \pm 6V$  (continued)**

At  $T_A = +25^\circ C$ ,  $G = +2$ ,  $R_F = 402\Omega$ , and  $R_L = 100\Omega$ , unless otherwise noted.

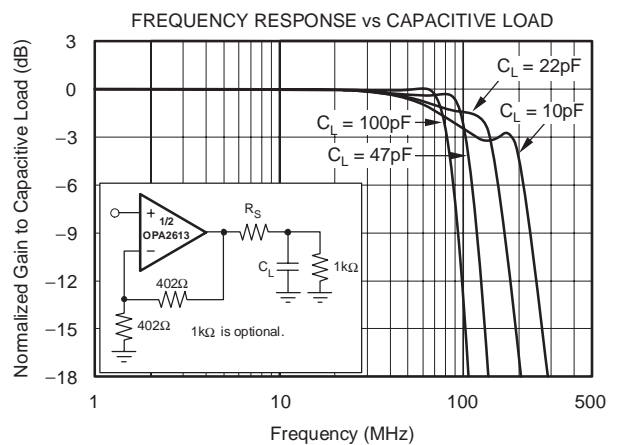
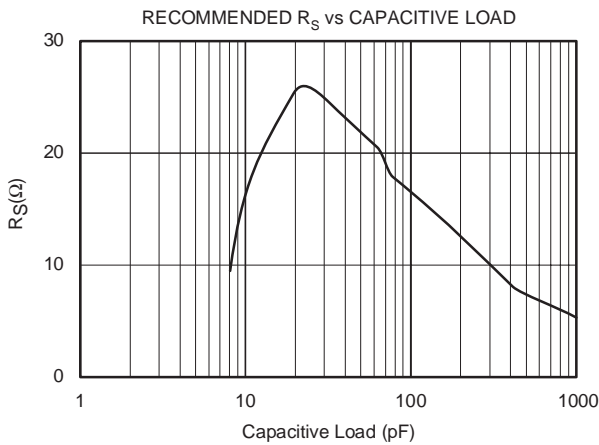
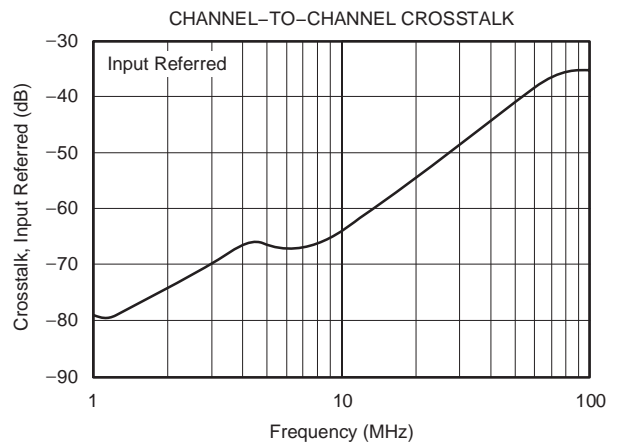
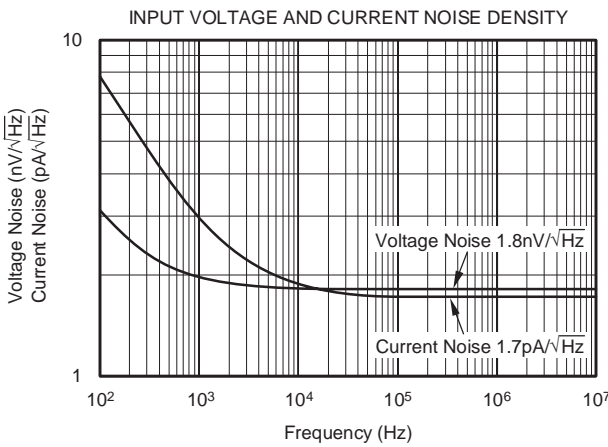
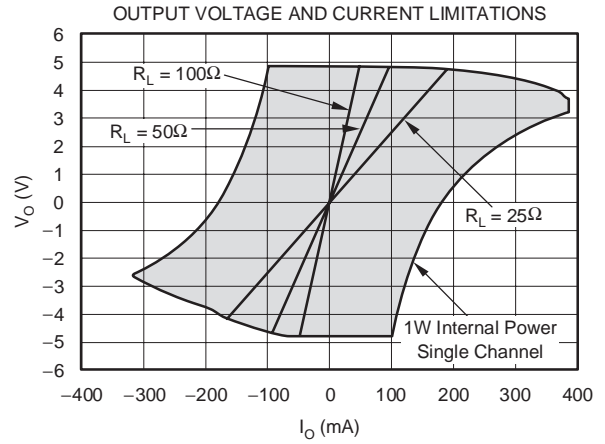
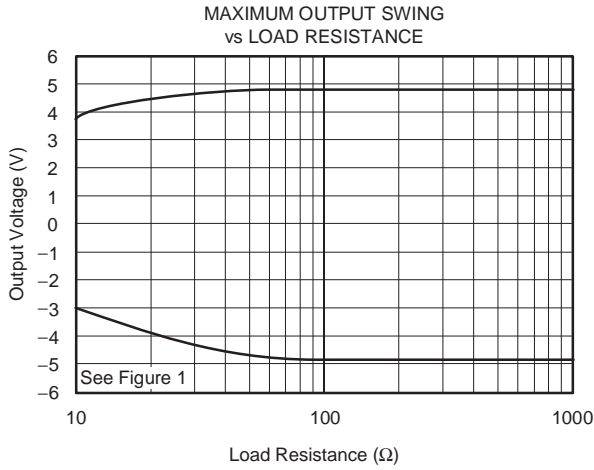

**TYPICAL CHARACTERISTICS:  $V_S = \pm 6V$  (continued)**

At  $T_A = +25^\circ C$ ,  $G = +2$ ,  $R_F = 402\Omega$ , and  $R_L = 100\Omega$ , unless otherwise noted.

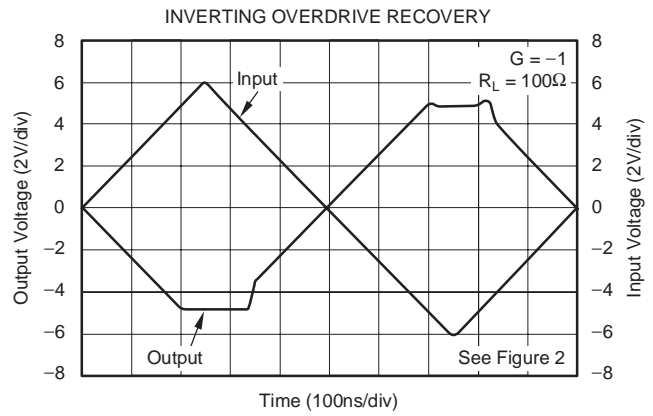
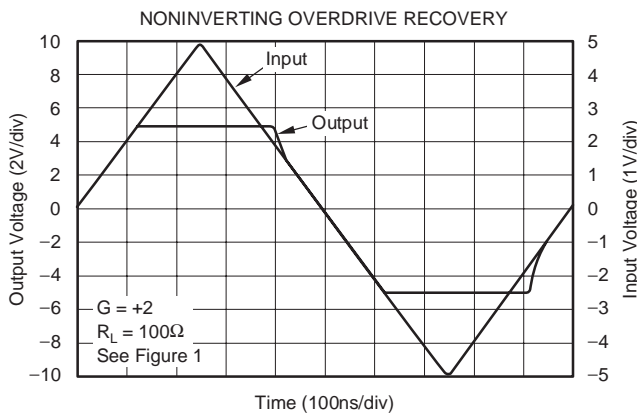
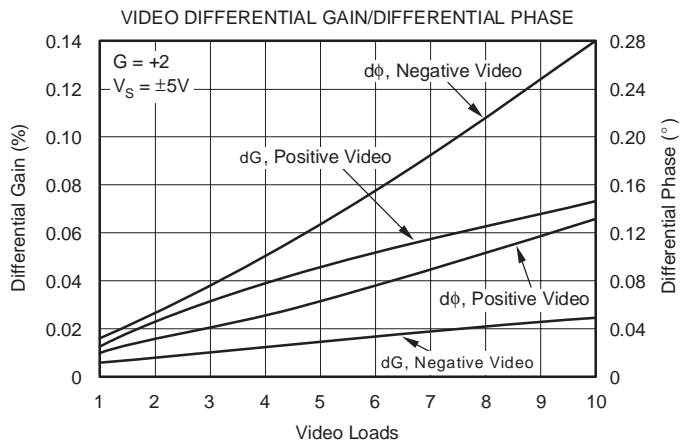
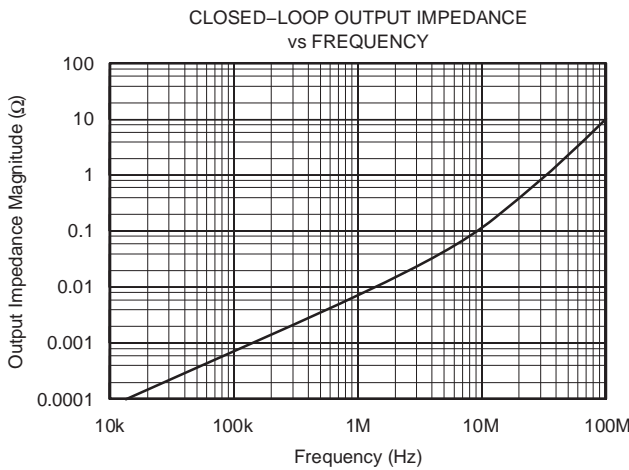
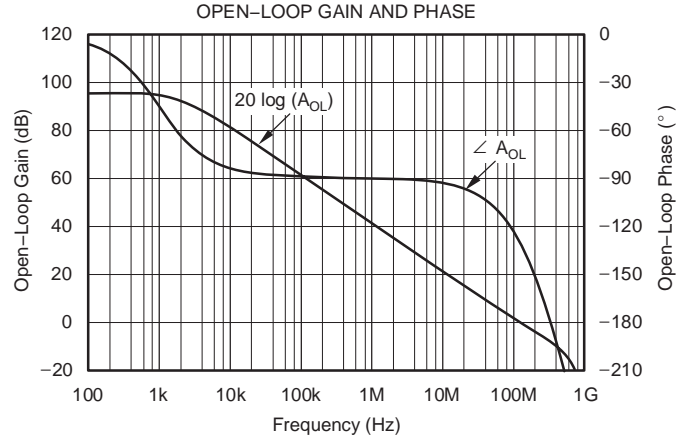
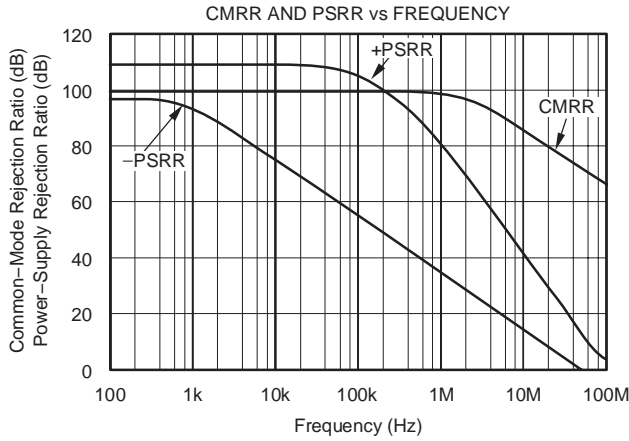

**TYPICAL CHARACTERISTICS:  $V_S = \pm 6V$  (continued)**

At  $T_A = +25^\circ C$ ,  $G = +2$ ,  $R_F = 402\Omega$ , and  $R_L = 100\Omega$ , unless otherwise noted.

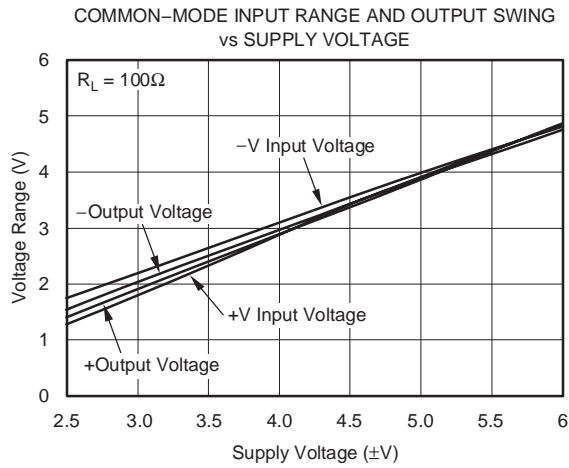
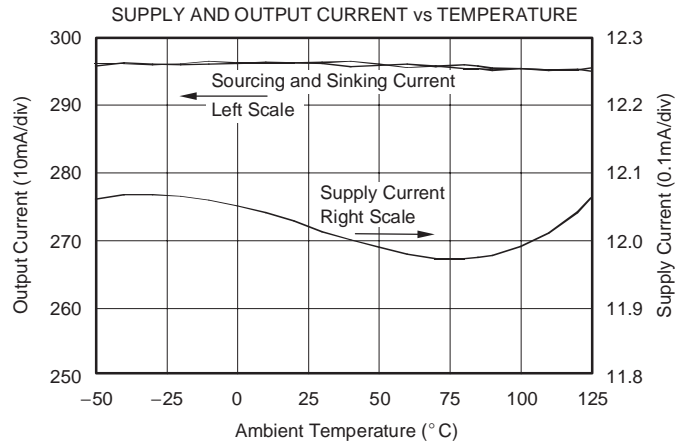
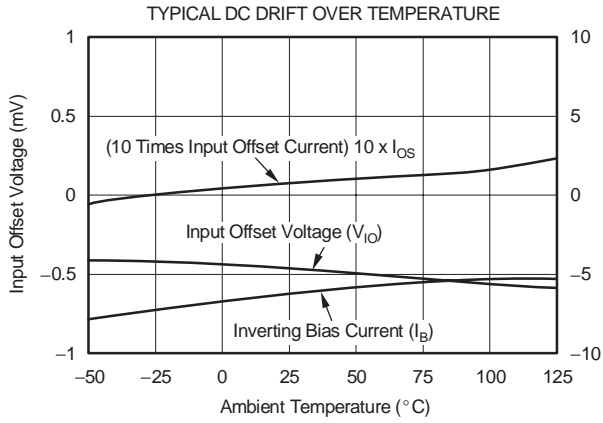

**TYPICAL CHARACTERISTICS:  $V_S = \pm 6V$ , Differential Configuration**

At  $T_A = +25^\circ C$ , Differential Gain = 4,  $R_F = 402\Omega$ , and  $R_L = 70\Omega$ , unless otherwise noted. See Figure 5 for AC performance only.

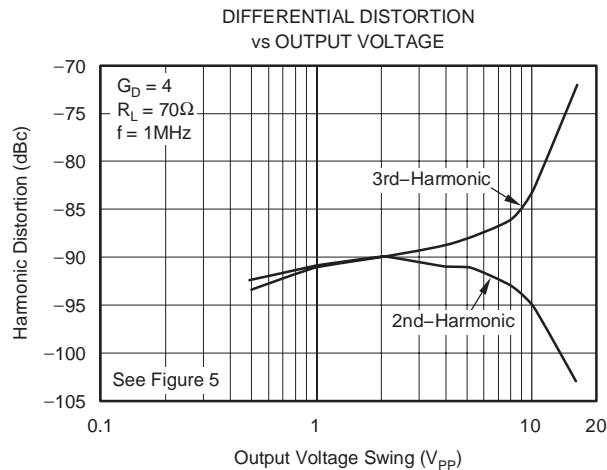
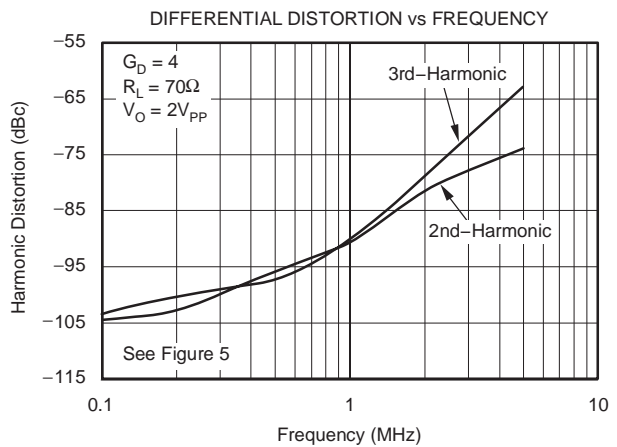
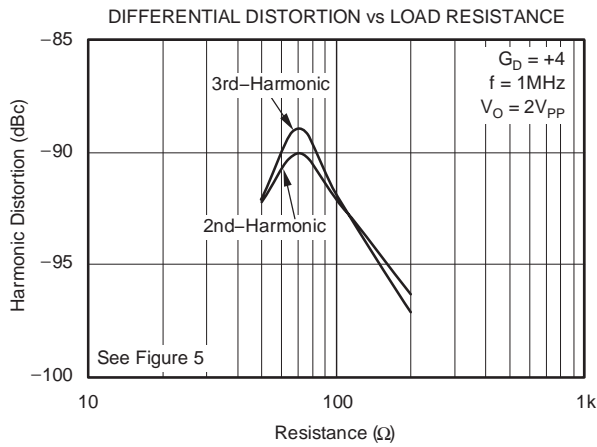
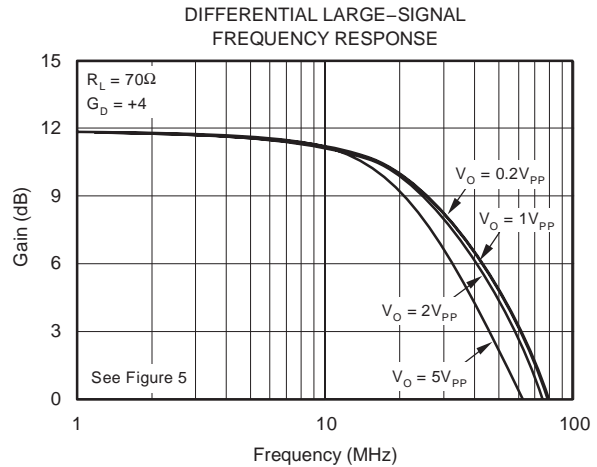
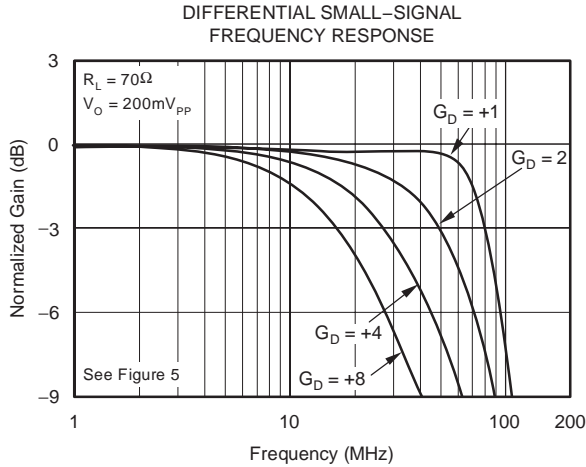

**TYPICAL CHARACTERISTICS:  $V_S = +5V$**

At  $T_A = +25^\circ C$ ,  $G = +2$ ,  $R_F = 402\Omega$ , and  $R_L = 100\Omega$ , unless otherwise noted.

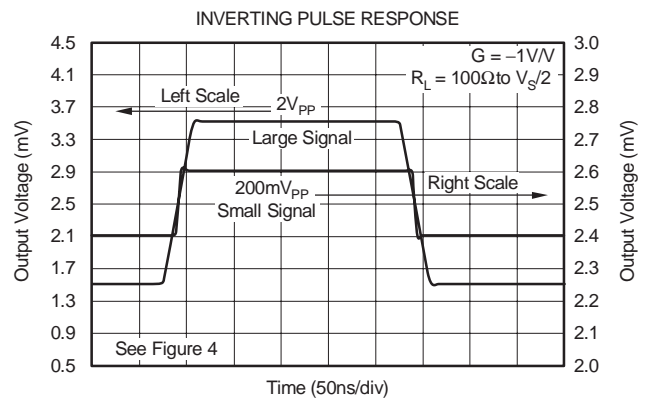
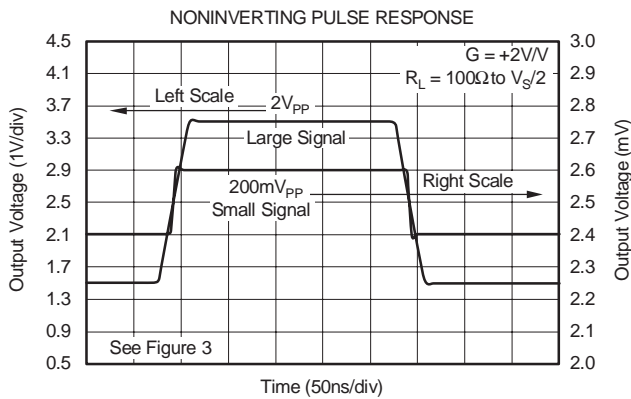
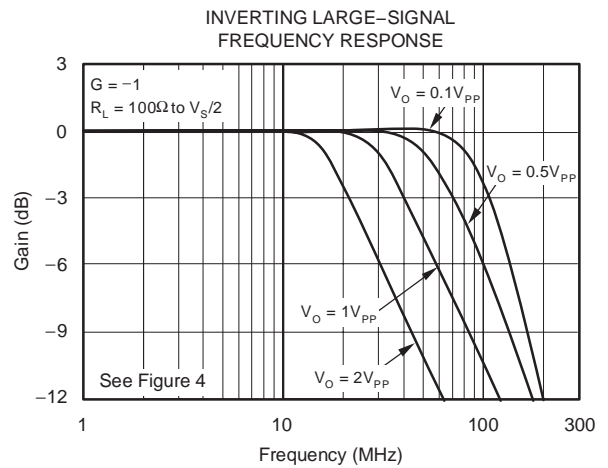
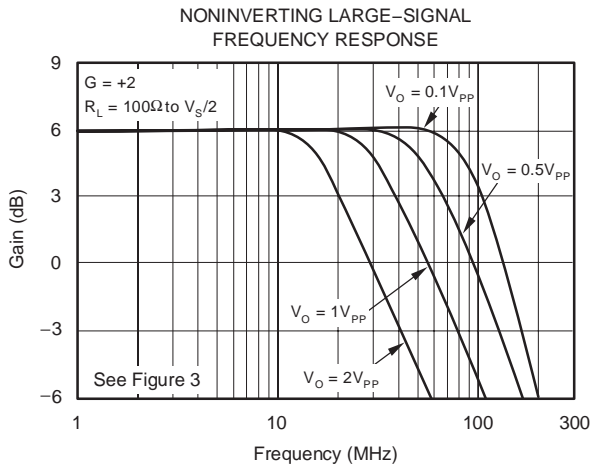
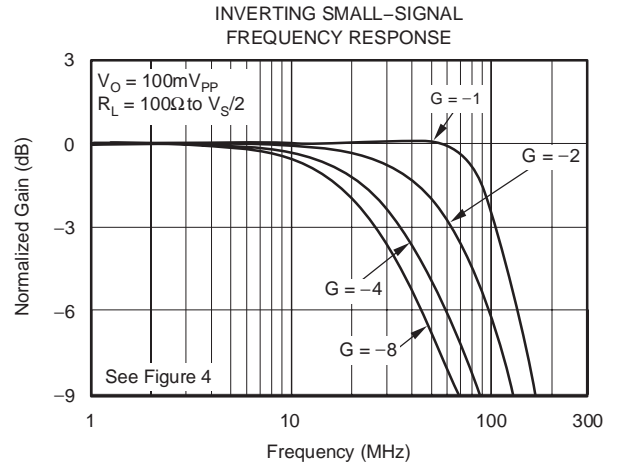
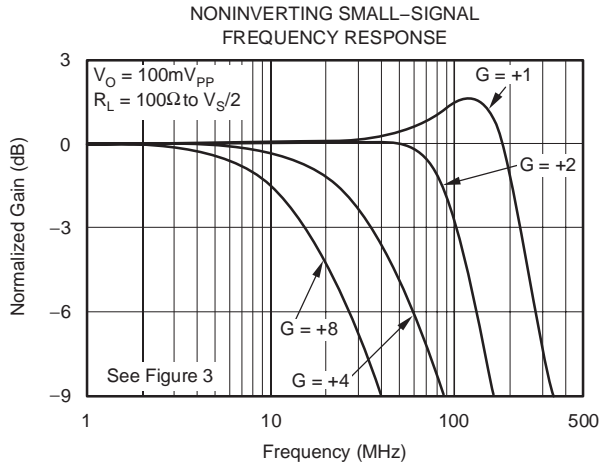

**TYPICAL CHARACTERISTICS:  $V_S = +5V$  (continued)**

At  $T_A = +25^\circ C$ ,  $G = +2$ ,  $R_F = 402\Omega$ , and  $R_L = 100\Omega$ , unless otherwise noted.

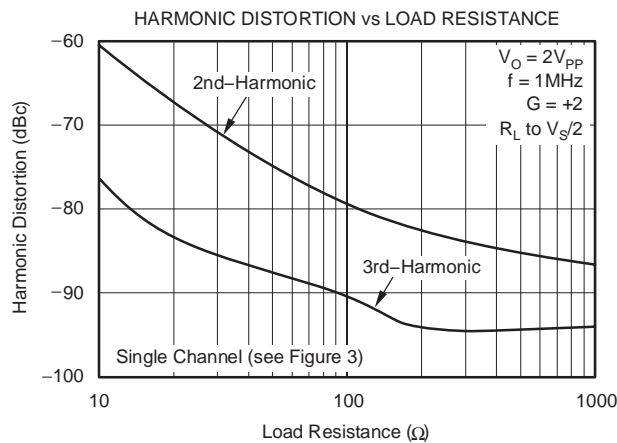
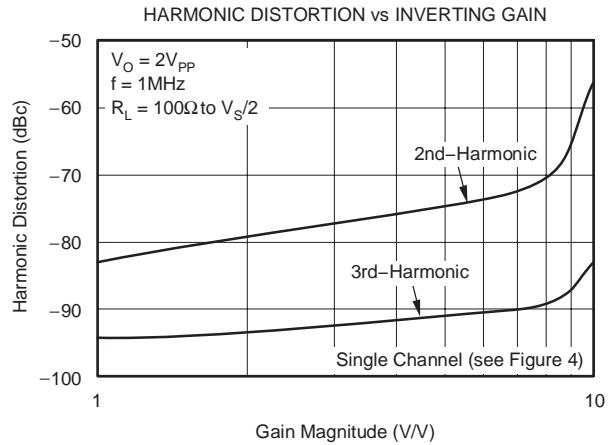
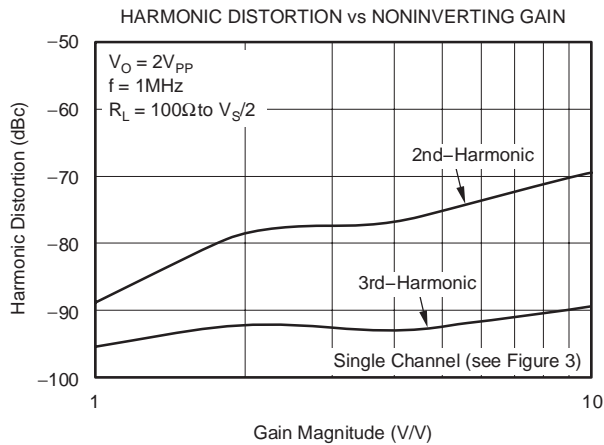
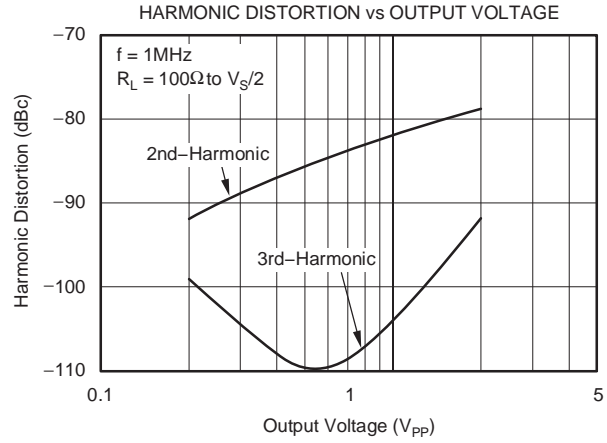
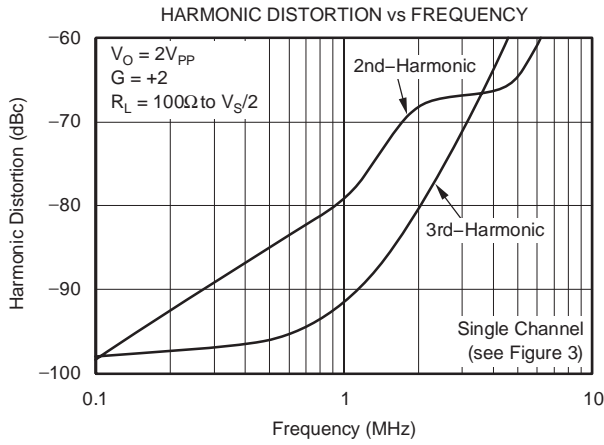

**TYPICAL CHARACTERISTICS:  $V_S = +5V$ , Differential Configuration**

At  $T_A = +25^\circ C$ ,  $G_D = 4$ ,  $R_F = 402\Omega$ , and  $R_L = 70\Omega$ , unless otherwise noted.

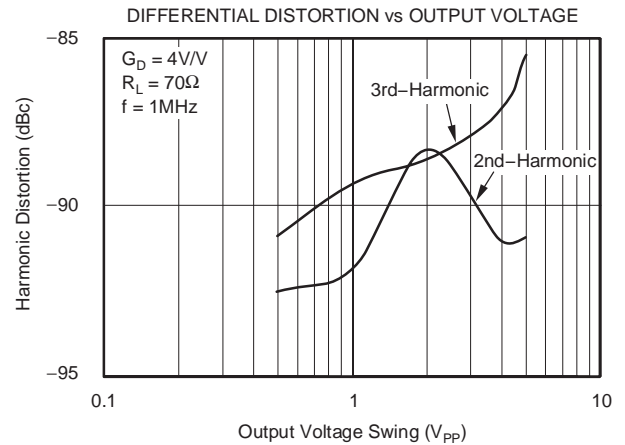
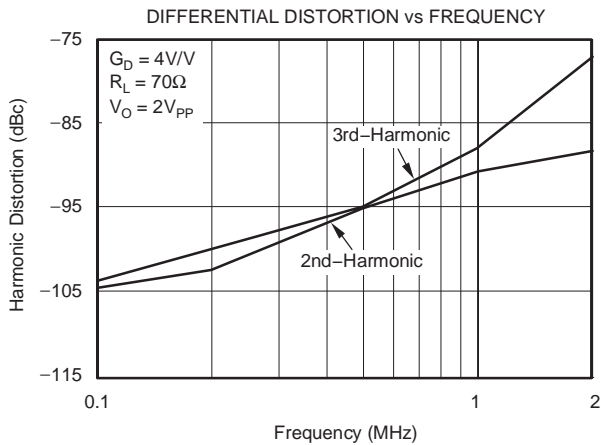
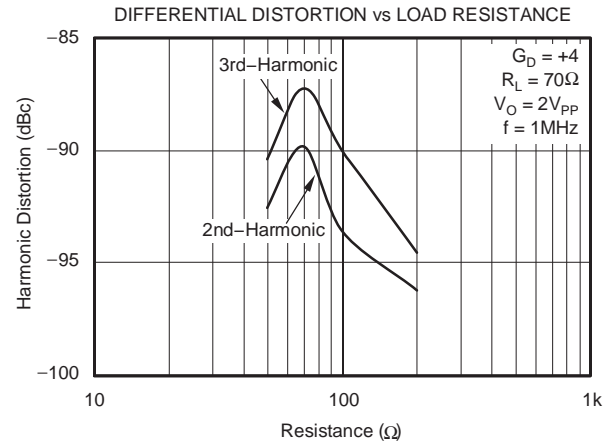
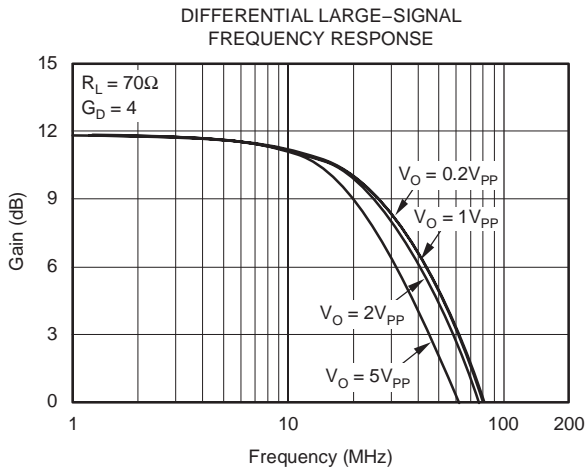
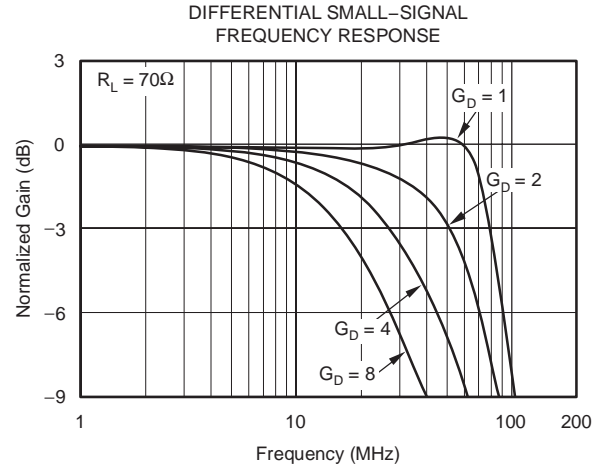
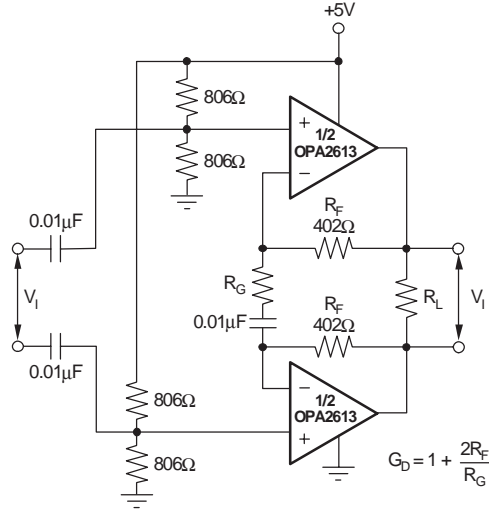

## APPLICATION INFORMATION

### WIDEBAND VOLTAGE-FEEDBACK OPERATION

The OPA2613 gives the exceptional AC performance of a wideband voltage-feedback op amp with a highly linear, high-power output stage. Requiring only 6mA/ch quiescent current, the OPA2613 swings to within 1.0V of either supply rail and delivers in excess of 280mA at room temperature. This low-output headroom requirement, along with supply voltage independent biasing, gives remarkable single (+5V) supply operation. The OPA2613 delivers greater than 20MHz bandwidth driving a 2V<sub>PP</sub> output into 100Ω on a single +5V supply. Previous boosted output stage amplifiers typically suffer from very poor crossover distortion as the output current goes through zero. The OPA2613 achieves exceptional power gain with much better linearity. Figure 1 shows the DC-coupled, gain of +2, dual power-supply circuit configuration used as the basis of the ±6V Electrical and Typical Characteristics. For test purposes, the input impedance is set to 50Ω with a resistor to ground; and the output impedance is set to 50Ω with a series output resistor. Voltage swings reported in the electrical characteristics are taken directly at the input and output pins, whereas load powers (dBm) are defined at a matched 50Ω load. For the circuit of Figure 1, the total effective load is 100Ω || 804Ω = 89Ω.

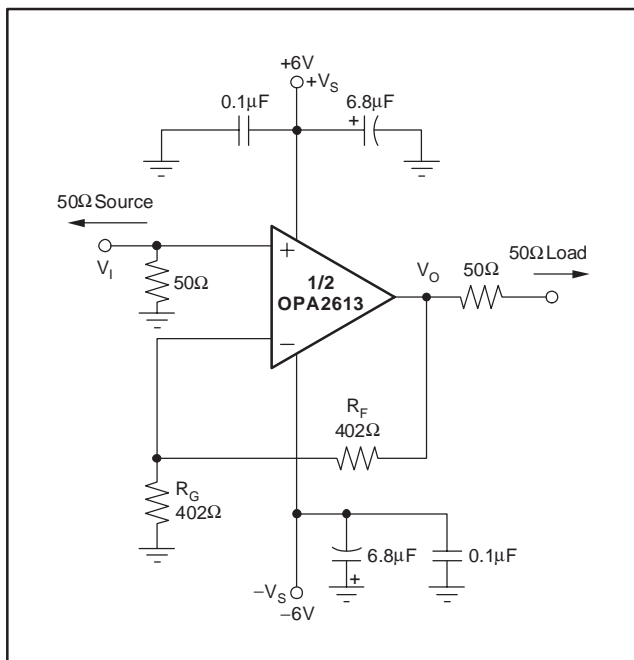

**Figure 1. DC-Coupled, G = +2, Bipolar Supply, Specification and Test Circuit**

Figure 2 shows the DC-coupled, bipolar supply circuit configuration used as the basis for the Inverting Gain -1V/V Typical Characteristics. Key design considerations of the inverting configuration are developed in the *Inverting Amplifier Operation* section.

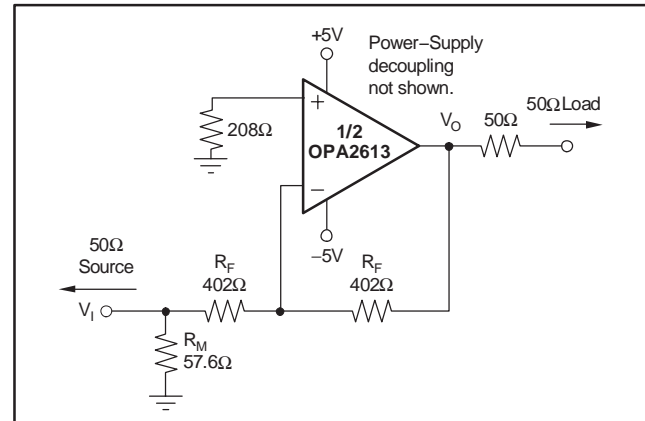

**Figure 2. DC-Coupled, G = -1, Bipolar Supply, Specification and Test Circuit**

Figure 3 shows the AC-coupled, gain of +2, single-supply circuit configuration used as the basis of the +5V Electrical and Typical Characteristics. Though not a *rail-to-rail* design, the OPA2613 requires minimal input and output voltage headroom compared to other very wideband voltage-feedback op amps. It will deliver a 2.6V<sub>PP</sub> output swing on a single +5V supply with greater than 20MHz bandwidth. The key requirement of broadband single-supply operation is to maintain input and output signal swings within the usable voltage ranges at both the input and the output. The circuit of Figure 3 establishes an input midpoint bias using a simple resistive divider from the +5V supply (two 806Ω resistors). The input signal is then AC-coupled into this midpoint voltage bias. The input voltage can swing to within 1.4V of either supply pin, giving a 2.2V<sub>PP</sub> input signal range centered between the supply pins. The input impedance matching resistor (57.6Ω) used for testing is adjusted to give a 50Ω input match when the parallel combination of the biasing divider network is included. The gain resistor (R<sub>G</sub>) is AC-coupled, giving the circuit a DC gain of +1—which puts the input DC bias voltage (2.5V) on the output as well. Again, on a single +5V supply, the output voltage can swing to within 1.1V of either supply pin while delivering more than 100mA output current. A demanding 100Ω load to a midpoint bias is used in this characterization circuit. The new output stage used in the OPA2613 can deliver large bipolar output currents into this midpoint load with minimal crossover distortion, as shown by the +5V supply, harmonic distortion plots.

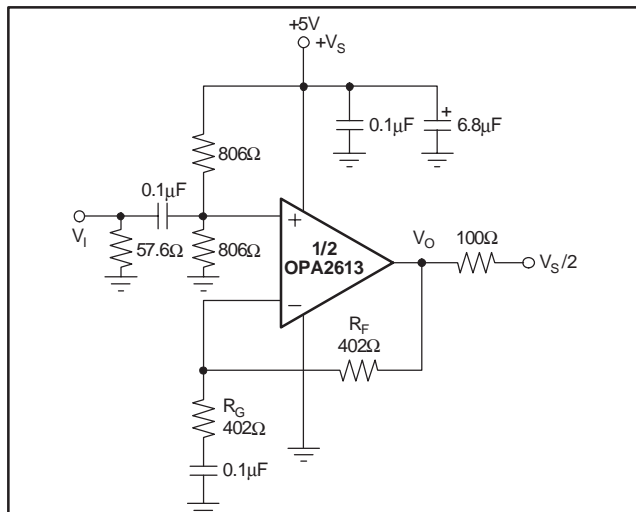

**Figure 3. AC-Coupled, G = +2, Single-Supply, Specification and Test Circuit**

The last configuration used as the basis of the +5V Electrical and Typical Characteristics is shown in Figure 4. Design considerations for this inverting, bipolar supply configuration are covered either in single-supply configuration (as shown in Figure 3) or in the *Inverting Amplifier Operation* section.

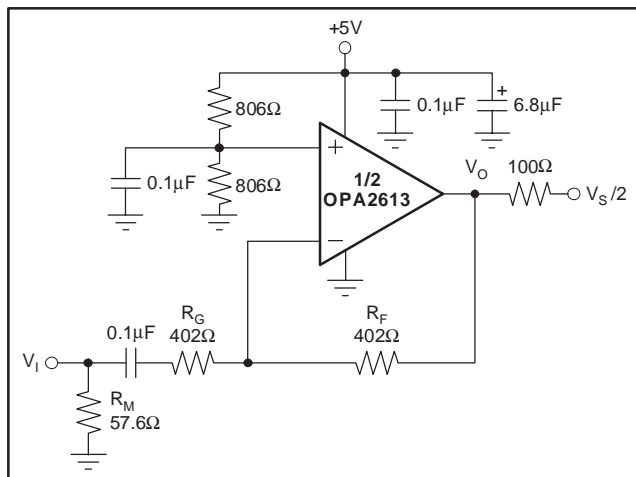
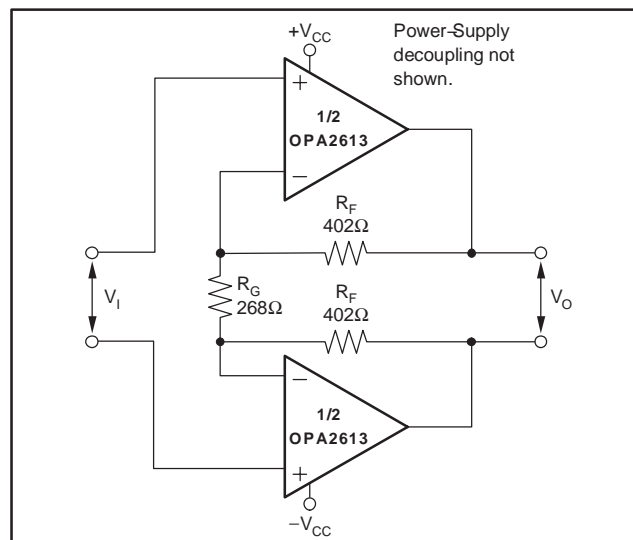

**Figure 4. AC-Coupled, G = -1, Single-Supply, Specification and Test Circuit**

## DIFFERENTIAL INTERFACE APPLICATIONS

Dual op amps are particularly suitable to differential input to differential output applications. Typically, these fall into either Analog-to-Digital Converter (ADC) input interface or line driver applications. Two basic approaches to differential I/O are noninverting or inverting configurations. Since the output is differential, the signal polarity is somewhat meaningless—the noninverting and inverting terminology applies here to where the input is brought into

the OPA2613. Each has its advantages and disadvantages. Figure 5 shows a basic starting point for noninverting input differential I/O applications.



**Figure 5. Noninverting Differential I/O Amplifier**

This approach provides for a source termination impedance that is independent of the signal gain. For instance, simple differential filters may be included in the signal path right up to the noninverting inputs without interacting with the gain setting. The differential signal gain for the circuit of Figure 5 is:

$$A_D = 1 + 2 \times \frac{R_F}{R_G} \quad (1)$$

Since the OPA2613 is a voltage-feedback (VFB) amplifier, its bandwidth is principally controlled by the noise gain. The equivalent noise gain for Figure 5 is:

$$1 + 2 \times \frac{402\Omega}{268\Omega} = 4V/V \quad (2)$$

Various combinations of single-supply or AC-coupled gain can also be delivered using the basic circuit of Figure 5. Common-mode bias voltages on the two noninverting inputs pass on to the output with a gain of 1 since an equal DC voltage at each inverting node creates no current through  $R_G$ . This circuit does show a common-mode gain of 1 from input to output. The source connection should either remove this common-mode signal if undesired (using an input transformer can provide this function), or the common-mode voltage at the inputs can be used to set the output common-mode bias. If the low common-mode rejection of this circuit is a problem, the output interface may also be used to reject that common-mode. For instance, most modern differential input ADCs reject common-mode signals very well, while a line driver application through a transformer will also remove the common-mode signal through to the line.

### SINGLE-SUPPLY ADSL UPSTREAM DRIVER

Figure 6 shows an example of a single-supply ADSL upstream driver. The dual OPA2613 is configured as a differential gain stage to provide signal drive to the primary of the transformer (here, a step-up transformer with a turns ratio of 1:2). The main advantage of this configuration is the cancellation of all even harmonic distortion products. Another important advantage for ADSL is that each amplifier needs only to swing half of the total output required driving the load.

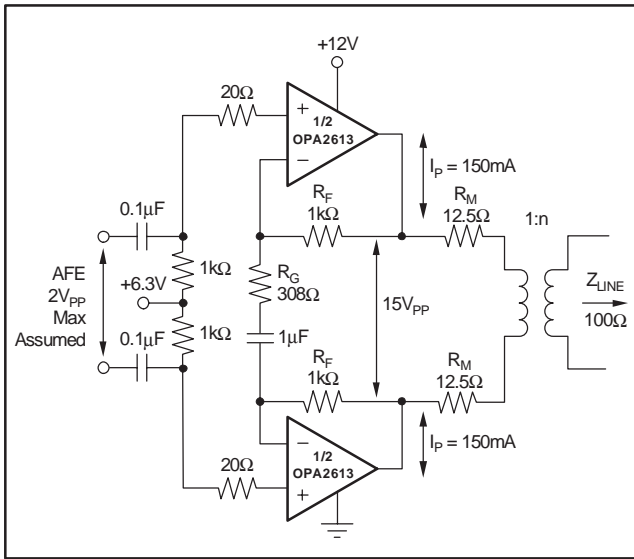

Figure 6. Single-Supply ADSL Upstream Driver

The analog front-end (AFE) signal is AC-coupled to the driver, and the noninverting input of each amplifier is biased slightly above the mid-supply voltage (+6.3V in this case). In addition to providing the proper biasing to the amplifier, this approach also provides a high-pass filtering with a corner frequency, set here at 1.6kHz. As the upstream signal bandwidth starts at 26kHz, this high-pass filter does not generate any problems and has the advantage of filtering out unwanted lower frequencies.

The input signal is amplified with a gain set by the following equation:

$$G_D = 1 + \frac{2 \times R_F}{R_G} \quad (3)$$

With  $R_F = 1\text{k}\Omega$  and  $R_G = 308\Omega$ , the gain for this differential amplifier is 7.5. This gain boosts the AFE signal, assumed to be a maximum of  $2V_{PP}$ , to a maximum of  $15V_{PP}$ .

The two back-termination resistors ( $12.5\Omega$  each) added at each input of the transformer make the impedance of the modem match the impedance of the phone line, and also provide a means of detecting the received signal for the

receiver. The value of these resistors ( $R_M$ ) is a function of the line impedance and the transformer turns ratio ( $n$ ), given by the following equation:

$$R_M = \frac{Z_{LINE}}{2n^2} \quad (4)$$

### LINE DRIVER HEADROOM MODEL

The first step in a transformer-coupled, twisted-pair driver design is to compute the peak-to-peak output voltage from the target specifications. This is done using the following equations:

$$P_L = 10 \times \log \frac{V_{RMS}^2}{(1\text{mW}) \times R_L} \quad (5)$$

With  $P_L$  power and  $V_{RMS}$  voltage at the load, and  $R_L$  load impedance, this gives the following:

$$V_{RMS} = \sqrt{(1\text{mW}) \times R_L \times 10^{\frac{P_L}{10}}} \quad (6)$$

$$V_P = \text{Crest Factor} \times V_{RMS} = \text{CF} \times V_{RMS} \quad (7)$$

with  $V_P$  peak voltage at the load and CF Crest Factor.

$$V_{LPP} = 2 \times \text{CF} \times V_{RMS} \quad (8)$$

with  $V_{LPP}$ : peak-to-peak voltage at the load.

Consolidating Equations 4 through 7 allows expressing the required peak-to-peak voltage at the load as a function of the crest factor, the load impedance, and the power at the load. Thus,

$$V_{LPP} = 2 \times \text{CF} \times \sqrt{(1\text{mW}) \times R_L \times 10^{\frac{P_L}{10}}} \quad (9)$$

This  $V_{LPP}$  is usually computed for a nominal line impedance and may be taken as a fixed design target.

The next step for the driver is to compute the individual amplifier output voltage and currents as a function of  $V_{PP}$  on the line and transformer turns ratio. As the turns ratio changes, the minimum allowed supply voltage changes along with it. The peak current in the amplifier output is given by:

$$\pm I_P = \frac{1}{2} \times \frac{2 \times V_{LPP}}{n} \times \frac{1}{4R_M} \quad (10)$$

With  $V_{LPP}$  as defined in Equation 8, and  $R_M$  as defined in Equation 4 and shown in Figure 7.

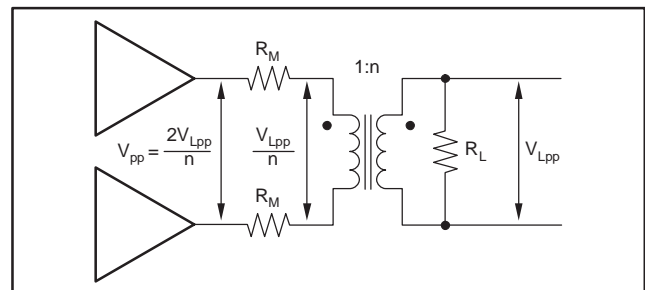

Figure 7. Driver Peak Output Voltage

With the previous information available, it is now possible to select a supply voltage and the turns ratio desired for the transformer as well as calculate the headroom for the OPA2613.

The model (shown in Figure 8) can be described with the following set of equations:

1. First, as available output swing:

$$V_{PP} = V_{CC} - (V_1 + V_2) - I_P \times (R_1 + R_2) \quad (11)$$

2. Or as required supply voltage:

$$V_{CC} = V_{PP} + (V_1 + V_2) + I_P \times (R_1 + R_2) \quad (12)$$

The minimum supply voltage for a power and load requirement is given by Equation 11.

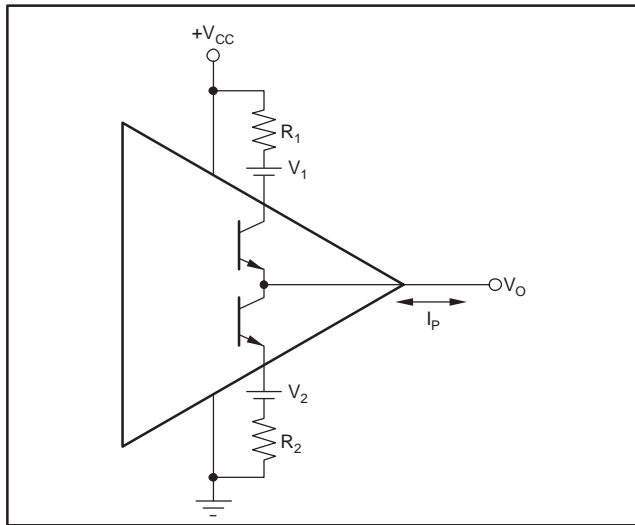

Figure 8. Line Driver Headroom Model

$V_1$ ,  $V_2$ ,  $R_1$ , and  $R_2$  are given in Table 1 for both +12V and +5V operation.

Table 1. Line Driver Headroom Model Values

	$V_1$	$R_1$	$V_2$	$R_2$
+5V	1.0V	2Ω	1.0V	5.5Ω
+12V	1.0V	2Ω	1.0V	5.5Ω

## TOTAL DRIVER POWER FOR xDSL APPLICATIONS

The total internal power dissipation for the OPA2613 in an xDSL line driver application will be the sum of the quiescent power and the output stage power. The

OPA2613 holds a relatively constant quiescent current versus supply voltage—giving a power contribution that is simply the quiescent current times the supply voltage used (the supply voltage will be greater than the solution given in Equation 12). The total output stage power may be computed with reference to Figure 9.

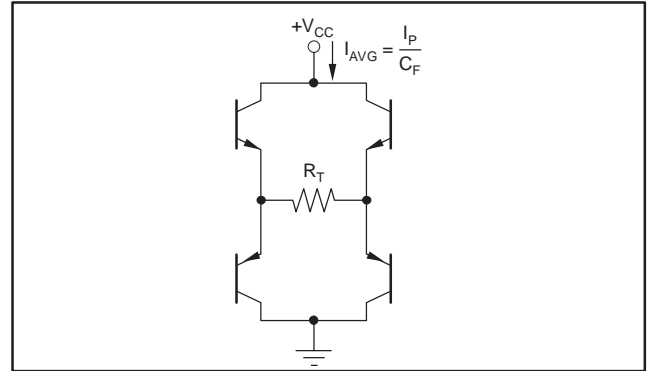

Figure 9. Output Stage Power Model

The two output stages used to drive the load of Figure 7 can be seen as an H-Bridge in Figure 9. The average current drawn from the supply into this H-Bridge and load will be the peak current in the load given by Equation 10 divided by the crest factor (CF) for the xDSL modulation. This total power from the supply is then reduced by the power in  $R_T$  to leave the power dissipated internal to the drivers in the four output stage transistors. That power is simply the target line power used in Equation 5 plus the power lost in the matching elements ( $R_M$ ). In the examples here, a perfect match is targeted giving the same power in the matching elements as in the load. The output stage power is then set by Equation 13.

$$P_{OUT} = \frac{I_P}{CF} \times V_{CC} - 2P_L \quad (13)$$

The total amplifier power is then:

$$P_{TOT} = I_q \times V_{CC} + \frac{I_P}{CF} \times V_{CC} - 2P_L \quad (14)$$

For the ADSL CPE upstream driver design of Figure 6, the peak current is 150mA for a signal that requires a crest factor of 5.33 with a target line power of 13dBm into 100Ω (20mW). With a typical quiescent current of 12mA and a nominal supply voltage of +12V, the total internal power dissipation for the solution of Figure 6 will be:

$$P_{TOT} = 12\text{mA}(12\text{V}) + \frac{150\text{mA}}{5.33}(12\text{V}) - 2(20\text{mW}) = 400\text{mW} \quad (15)$$

## DESIGN-IN TOOLS

### DEMONSTRATION FIXTURE

A printed circuit board (PCB) is available to assist in the initial evaluation of circuit performance using the OPA2613. The fixture is offered free of charge as an unpopulated PCB, delivered with a user's guide. The summary information for this fixture is shown in Table 2.

**Table 2. Demonstration Fixture**

PRODUCT	PACKAGE	ORDERING NUMBER	LITERATURE NUMBER
OPA2613ID	SO-8	DEM-OPA-SO-2A	SBOU003

The demonstration fixture can be requested at the Texas Instruments web site (www.ti.com) through the OPA2613 product folder.

### MACROMODELS AND APPLICATIONS SUPPORT

Computer simulation of circuit performance using SPICE is often useful when analyzing the performance of analog circuits and systems. This is particularly true for video and RF amplifier circuits where parasitic capacitance and inductance can have a major effect on circuit performance. A SPICE model for the OPA2613 is available through the TI web site (www.ti.com). This model does a good job of predicting small-signal AC and transient performance under a wide variety of operating conditions, but does not do as well in predicting the harmonic distortion or video  $d_G/d_P$  characteristics. This model does not attempt to distinguish between the package types in small-signal AC performance, nor does it attempt to simulate channel-to-channel coupling.

### INVERTING AMPLIFIER OPERATION

As the OPA2613 is a general-purpose, wideband voltage-feedback op amp, most of the familiar op amp application circuits are available to the designer. Wideband inverting operation is particularly suited to the OPA2613. Figure 10 shows a typical inverting configuration where the I/O impedances and signal gain from Figure 1 are retained in an inverting circuit configuration.

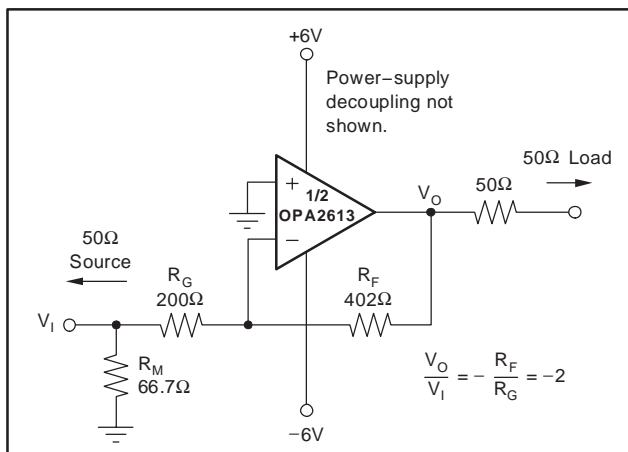

**Figure 10. Inverting Gain of  $-1$  with Impedance Matching**

In the inverting configuration, two key design considerations must be noted. The first is that the gain resistor ( $R_G$ ) becomes part of the input impedance. If input impedance matching is desired (which is beneficial whenever the signal is coupled through a cable, twisted-pair, long PC board trace, or other transmission line conductor), it is normally necessary to add an additional matching resistor to ground.  $R_G$ , by itself, is not normally set to the required input impedance since its value, along with the desired gain, will determine an  $R_F$ , which may be non-optimal from a frequency response standpoint. The total input impedance for the source becomes the parallel combination of  $R_G$  and  $R_M$ .

The second major consideration, touched on in the previous paragraph, is that the signal source impedance becomes part of the noise gain equation and has an effect on the bandwidth. In the example of Figure 10, the  $R_M$  value combines in parallel with the external  $50\Omega$  source impedance, yielding an effective driving impedance of  $50\Omega \parallel 66.7\Omega = 28.6\Omega$ . This impedance is added in series with  $R_G$  for calculating the noise gain—which gives  $NG = 2.76$ . Note that the noninverting input in this bipolar supply inverting application is connected to ground through a  $146\Omega$  resistor. It is often suggested that an additional resistor be connected to ground on the noninverting input to achieve bias current error cancellation at the output.

## OUTPUT CURRENT AND VOLTAGE

The OPA2613 provides output voltage and current capabilities that are unsurpassed in a low-cost dual monolithic op amp. Under no-load conditions at 25°C, the output voltage typically swings closer than 1V to either supply rail; tested at +25°C, swing limit is within 1.1V of either rail. Into a 12Ω load (the minimum tested load), it delivers more than ±280mA continuous output current. The specifications described previously, though familiar in the industry, consider voltage and current limits separately. In many applications, it is the voltage times current (or V-I product) that is more relevant to circuit operation. Refer to the *Output Voltage and Current Limitations* plot in the Typical Characteristics. The X and Y axes of this graph show the zero-voltage output current limit and the zero-current output voltage limit, respectively. The four quadrants give a more detailed view of the OPA2613 output drive capabilities, noting that the graph is bounded by a safe operating area of 1W maximum internal power dissipation (in this case, for one channel only). Superimposing resistor load lines onto the plot shows that the OPA2613 can drive +4.8 and -4.1 into 25Ω without exceeding the output capabilities or the 1W dissipation limit. A 100Ω load line (the standard test circuit load) shows the full ±4.9V output swing capability, as shown in the Electrical Characteristics tables. The minimum specified output voltage and current over temperature are set by worst-case simulations at the cold temperature extreme. Only at cold startup will the output current and voltage decrease to the numbers shown in the Electrical Characteristics tables. As the output transistors deliver power, the junction temperatures increase, decreasing the  $V_{BE}$ s (increasing the available output voltage swing), and increasing the current gains (increasing the available output current). In steady-state operation, the available output voltage and current will always be greater than that shown in the over-temperature specifications, since the output stage junction temperatures will be higher than the minimum specified operating ambient.

## DRIVING CAPACITIVE LOADS

One of the most demanding and yet very common load conditions for an op amp is capacitive loading. Often, the capacitive load is the input of an ADC—including additional external capacitance that may be recommended to improve the ADC linearity. A high-speed, high open-loop gain amplifier like the OPA2613 can be very susceptible to decreased stability and closed-loop

response peaking when a capacitive load is placed directly on the output pin. When the amplifier open-loop output resistance is considered, this capacitive load introduces an additional pole in the signal path that can decrease the phase margin. Several external solutions to this problem have been suggested.

When the primary considerations are frequency response flatness, pulse response fidelity, and/or distortion, the simplest and most effective solution is to isolate the capacitive load from the feedback loop by inserting a series isolation resistor between the amplifier output and the capacitive load. This does not eliminate the pole from the loop response, but rather shifts it and adds a zero at a higher frequency. The additional zero acts to cancel the phase lag from the capacitive load pole, thus increasing the phase margin and improving stability. The Typical Characteristics show the Recommended  $R_S$  vs Capacitive Load and the resulting frequency response at the load. Parasitic capacitive loads greater than 2pF can begin to degrade the performance of the OPA2613. Long PCB traces, unmatched cables, and connections to multiple devices can easily cause this value to be exceeded. Always consider this effect carefully, and add the recommended series resistor as close as possible to the OPA2613 output pin (see the *Board Layout Guidelines* section).

The very high output current and unity gain stability for the OPA2613 can be used to drive large capacitive loads with moderate slew rates. An example is shown in Figure 11 where a 5000pF load cap is driven with a 1MHz square wave to give a ±5V swing. The supplies were slightly increased to give more headroom for the charging current through the 2Ω isolation resistor.

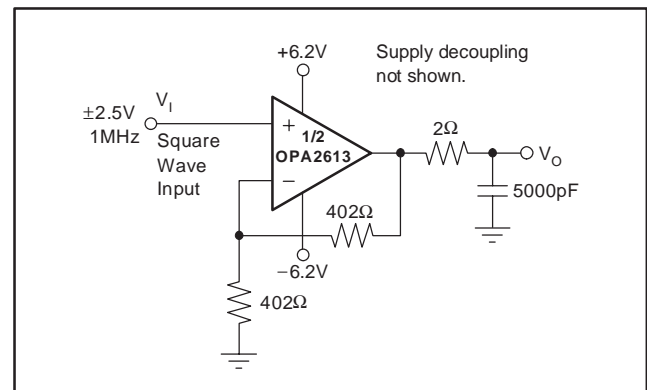

Figure 11. Large Capacitive Load Driver

Figure 12 shows a comparison of  $2 \times$  Input voltage to the capacitor voltage. The transition time is set by the  $70\text{V}/\mu\text{s}$  slew rate for the OPA2613. For this controlled  $dV/dT$ , the charging current into the  $5000\text{pF}$  load will be given by:

$$\text{Slew Rate} = I_P/C$$

Solving for  $I_P$  gives:

$$I_P = 5000\text{pF} \times 70\text{V}/\mu\text{s} = 350\text{mA peak current} \quad (16)$$

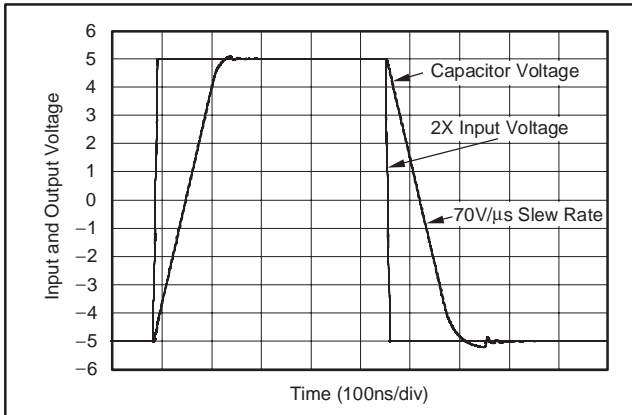

Figure 12. Large-Signal Capacitive Load Drive

At these larger capacitive loads, very low series R will maintain stability—but some R is always required.

### DISTORTION PERFORMANCE

The OPA2613 provides good distortion performance into a  $100\Omega$  load on  $\pm 6\text{V}$  supplies. Generally, until the fundamental signal reaches high frequency or power levels, the 2nd-harmonic dominates the distortion with a negligible 3rd-harmonic component. Focusing then on the 2nd-harmonic, increasing the load impedance improves distortion directly. Remember that the total load includes the feedback network—in the noninverting configuration (see Figure 1), this is the sum of  $R_F + R_G$ , whereas in the inverting configuration, it is just  $R_F$ . Also, providing an additional supply decoupling capacitor ( $0.01\mu\text{F}$ ) between the supply pins (for bipolar operation) improves the 2nd-order distortion slightly (3dB to 6dB).

In most op amps, increasing the output voltage swing increases harmonic distortion directly. The Typical Characteristics show the 2nd-harmonic increasing at a little less than the expected  $2x$  rate whereas the 3rd-harmonic increases at a little less than the expected  $3x$  rate. Where the test power doubles, the difference between it and the 2nd-harmonic decreases less than the expected 6dB, whereas the difference between it and the 3rd-harmonic decreases by less than the expected 12dB. Operating differentially will suppress the 2nd-order harmonics below the 3rd.

Operating as a differential I/O stage will also suppress the 2nd-harmonic distortion.

### NOISE PERFORMANCE

Wideband voltage-feedback op amps generally have a lower output noise than comparable current-feedback op amps. The OPA2613 offers an excellent balance between voltage and current noise terms to achieve low output noise. The input voltage noise ( $1.8\text{nV}/\sqrt{\text{Hz}}$ ) is lower than most unity-gain stable, wideband voltage-feedback op amps. The op amp input voltage noise and the two input current noise terms combine to give low output noise under a wide variety of operating conditions. Figure 13 shows the op amp noise analysis model with all the noise terms included. In this model, all noise terms are taken to be noise voltage or current density terms in either  $\text{nV}/\sqrt{\text{Hz}}$  or  $\text{pA}/\sqrt{\text{Hz}}$ .

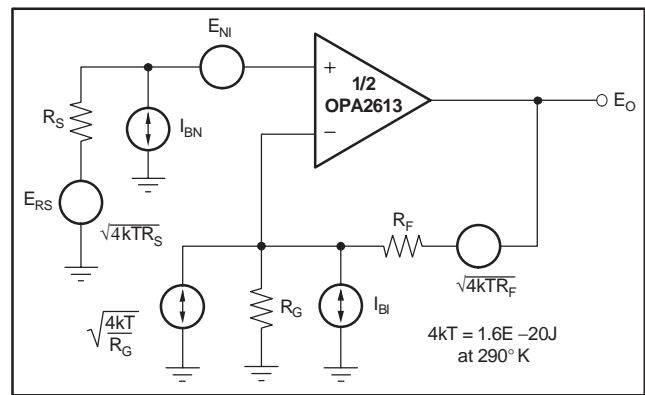

Figure 13. Op Amp Noise Analysis Model

The total output spot noise voltage can be computed as the square root of the sum of all squared output noise voltage contributors. Equation 17 shows the general form for the output noise voltage using the terms given in Figure 13.

$$E_O = \sqrt{\left( E_{NI}^2 + (I_{BN} \times R_S)^2 + 4kTR_S \right) NG^2 + (I_{BI} \times R_F)^2 + 4kTR_F NG} \quad (17)$$

Dividing this expression by the noise gain ( $NG = (1 + R_F/R_G)$ ) gives the equivalent input-referred spot noise voltage at the noninverting input, as shown in Equation 18.

$$E_N = \sqrt{E_{NI}^2 + (I_{BN} \times R_S)^2 + 4kTR_S + \left( \frac{I_{BI} \times R_F}{NG} \right)^2 + \frac{4kTR_F}{NG}} \quad (18)$$

Evaluating these two equations for the OPA2613 circuit and component values (see Figure 1) gives a total output spot noise voltage of  $6.34\text{nV}/\sqrt{\text{Hz}}$  and a total equivalent input spot noise voltage of  $3.2\text{nV}/\sqrt{\text{Hz}}$ . This total input referred spot noise voltage is higher than the  $1.8\text{nV}/\sqrt{\text{Hz}}$  specification for the op amp voltage noise alone. This reflects the noise added to the output by the inverting current noise times the feedback resistor.

## DIFFERENTIAL NOISE PERFORMANCE

As the OPA2613 is used as a differential driver in xDSL applications, it is important to analyze the noise in such a configuration. Figure 14 shows the op amp noise model for the differential configuration.

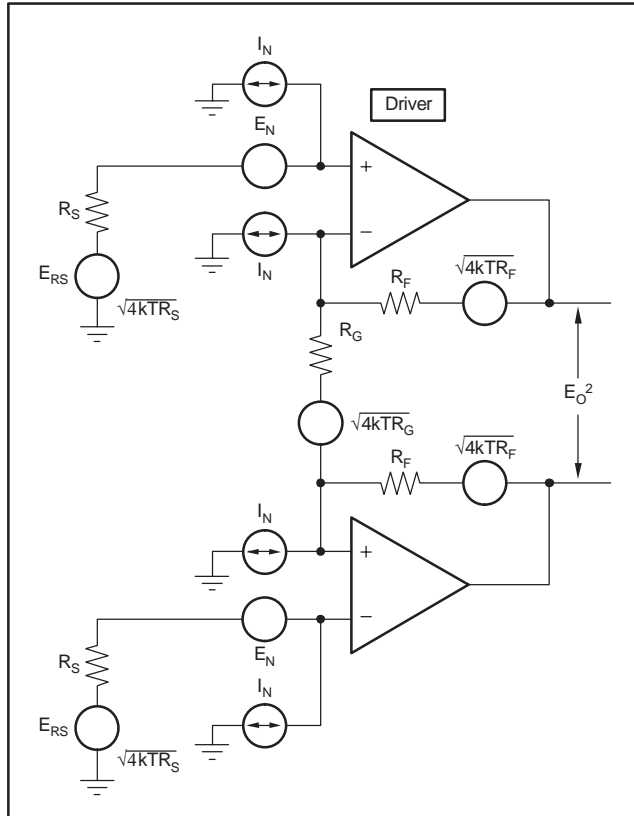

**Figure 14. Differential Op Amp Noise Analysis Model**

As a reminder, the differential gain is expressed as:

$$G_D = 1 + \frac{2 \times R_F}{R_G} \quad (19)$$

The output noise can be expressed as shown below:

$$e_o = \sqrt{2 \times G_D^2 \times \left( e_N^2 + (i_N \times R_S)^2 + 4kTR_S \right) + 2(i_{R_F})^2 + 2(4kTR_F G_D)} \quad (20)$$

Dividing this expression by the differential noise gain ( $G_D = (1 + 2R_F/R_G)$ ) gives the equivalent input referred spot noise voltage at the noninverting input, as shown in Equation 21.

$$e_i = \sqrt{2 \times \left( e_N^2 + (i_N \times R_S)^2 + 4kTR_S \right) + 2 \left( \frac{i_{R_F}}{G_D} \right)^2 + 2 \left( \frac{4kTR_F}{G_D} \right)} \quad (21)$$

Evaluating these equations for the OPA2613 ADSL circuit and component values of Figure 6 gives a total output spot noise voltage of  $23.3nV/\sqrt{Hz}$  and a total equivalent input spot noise voltage of  $3.2nV/\sqrt{Hz}$ .

In order to minimize the output noise due to the noninverting input bias current noise, it is recommended to keep the noninverting source impedance as low as possible.

## DC ACCURACY AND OFFSET CONTROL

The OPA2613 can provide excellent DC signal accuracy due to its high open-loop gain, high common-mode rejection, high power-supply rejection, and low input offset voltage and bias current offset errors. To take full advantage of the low input offset voltage ( $\pm 1.0mV$  maximum at  $25^\circ C$ ), careful attention to input bias current cancellation is also required. The high-speed input stage for the OPA2613 has relatively high input bias current ( $6\mu A$  typical into the pins) but with a very close match between the two input currents, typically  $50nA$  input offset current. The total output offset voltage may be reduced considerably by matching the source impedances looking out of the two inputs. For example, one way to add bias current cancellation to the circuit of Figure 1 would be to insert a  $175\Omega$  series resistor into the noninverting input from the  $50\Omega$  terminating resistor. If the  $50\Omega$  source resistor is DC-coupled, this will increase the source impedance for the noninverting input bias current to  $200\Omega$ . Since this is now equal to the impedance looking out of the inverting input ( $R_F \parallel R_G$ ), the circuit will cancel the bias current effects, leaving only the offset current times the feedback resistor as a residual DC error term at the output. Evaluating the configuration of Figure 1 adding a  $175\Omega$  in series with the noninverting input pin, using worst-case  $+25^\circ C$  input offset voltage and the two input bias currents, gives a worst-case output offset range equal to:

$$V_{OFF} = \pm (NG \times V_{OS(MAX)}) \pm (I_{OS} \times R_F)$$

where  $NG$  = noninverting signal gain

$$= \pm (2 \times 1.0mV) \pm (402\Omega \times 300nA)$$

$$= \pm 2.0mV \pm 0.12mV$$

$$V_{OFF} = \pm 2.12mV$$

## THERMAL ANALYSIS

Due to the high output power capability of the OPA2613, heat-sinking or forced airflow may be required under extreme operating conditions. Maximum desired junction temperature sets the maximum allowed internal power dissipation as described below. In no case should the maximum junction temperature be allowed to exceed  $150^\circ C$ . Operating junction temperature ( $T_J$ ) is given by  $T_A + P_D \times \theta_{JA}$ . The total internal power dissipation ( $P_D$ ) is the sum of quiescent power ( $P_{DQ}$ ) and additional power dissipation in the output stage ( $P_{DL}$ ) to deliver load power. Quiescent power is the specified no-load supply current times the total supply voltage across the part.  $P_{DL}$  depends

on the required output signal and load, but for a grounded resistive load,  $P_{DL}$  is at a maximum when the output is fixed at a voltage equal to 1/2 of either supply voltage (for equal bipolar supplies). Under this condition,  $P_{DL} = V_S^2 / (4 \times R_L)$  where  $R_L$  includes feedback network loading. Note that it is the power in the output stage and not into the load that determines internal power dissipation. As a worst-case example, compute the maximum  $T_J$  using an OPA2613 SO-8 in the circuit of Figure 1 operating at the maximum specified ambient temperature of +85°C with both outputs driving a grounded 20Ω load to +3.0V.

$$P_D = 12V \times 13.0mA + 2 \times [6^2 / (4 \times (20\Omega \parallel 804\Omega))] = 1.08W$$

$$\text{Maximum } T_J = +85^\circ\text{C} + (1.08W \times 125^\circ\text{C/W}) = 220^\circ\text{C}$$

This absolute worst-case condition exceeds specified maximum junction temperature. This extreme case is not normally encountered. Where high internal power dissipation is anticipated, consider the thermal slug package version. Under the same worst case conditions the junction temperature will drop to 139°C with the 50°C/W thermal impedance available using the PSO-8 package.

## BOARD LAYOUT GUIDELINES

Achieving optimum performance with a high-frequency amplifier like the OPA2613 requires careful attention to board layout parasitic and external component types. Recommendations that optimize performance include:

**a) Minimize parasitic capacitance** to any AC ground for all of the signal I/O pins. Parasitic capacitance on the output and inverting input pins can cause instability; on the noninverting input, it can react with the source impedance to cause unintentional band limiting. To reduce unwanted capacitance, a window around the signal I/O pins should be opened in all of the ground and power planes around those pins. Otherwise, ground and power planes should be unbroken elsewhere on the board.

**b) Minimize the distance** (< 0.25") from the power-supply pins to high-frequency 0.1μF decoupling capacitors. At the device pins, the ground and power plane layout should not be in close proximity to the signal I/O pins. Avoid narrow power and ground traces to minimize inductance between the pins and the decoupling capacitors. The power-supply connections (on pins 4 and 7) should always be decoupled with these capacitors. An optional supply decoupling capacitor across the two power supplies (for bipolar operation) improves 2nd-harmonic distortion performance. Larger (2.2μF to 6.8μF) decoupling capacitors, effective at a lower frequency, should also be used on the main supply pins. These can be placed somewhat farther from the device and may be shared among several devices in the same area of the PCB.

**c) Careful selection and placement of external components preserve the high-frequency performance of the OPA2613.** Resistors should be of a very low reactance type. Surface-mount resistors work best and allow a tighter overall layout. Metal film and carbon composition axially leaded resistors can also provide good high-frequency performance. Again, keep the leads and PC board trace length as short as possible. Never use wire-wound type resistors in a high-frequency application. Although the output pin and inverting input pin are the most sensitive to parasitic capacitance, always position the feedback and series output resistor, if any, as close as possible to the output pin. Other network components, such as noninverting input termination resistors, should also be placed close to the package. Where double-side component mounting is allowed, place the feedback resistor directly under the package on the other side of the board between the output and inverting input pins. The 402Ω feedback resistor used in the Typical Characteristics at a gain of +2 on ±6V supplies is a good starting point for design.

**d) Connections to other wideband devices** on the board may be made with short direct traces or through onboard transmission lines. For short connections, consider the trace and the input to the next device as a lumped capacitive load. Relatively wide traces (50mils to 100mils) should be used, preferably with ground and power planes opened up around them. Estimate the total capacitive load and set  $R_S$  from the plot of Recommended  $R_S$  vs Capacitive Load. Low parasitic capacitive loads (< 5pF) may not need an  $R_S$  because the OPA2613 is nominally compensated to operate with a 2pF parasitic load. If a long trace is required, and the 6dB signal loss intrinsic to a doubly-terminated transmission line is acceptable, implement a matched impedance transmission line using microstrip or stripline techniques (consult an ECL design handbook for microstrip and stripline layout techniques). A 50Ω environment is normally not necessary on board; in fact, a higher impedance environment improves distortion (see the distortion versus load plots). With a characteristic board trace impedance defined based on board material and trace dimensions, a matching series resistor into the trace from the output of the OPA2613 is used, as well as a terminating shunt resistor at the input of the destination device. Remember also that the terminating impedance is the parallel combination of the shunt resistor and the input impedance of the destination device.

This total effective impedance should be set to match the trace impedance. The high output voltage and current capability of the OPA2613 allows multiple destination devices to be handled as separate transmission lines, each with their own series and shunt terminations. If the 6dB attenuation of a doubly-terminated transmission line is unacceptable, a long trace can be series-terminated at the source end only. Treat the trace as a capacitive load in this case and set the series resistor value as shown in the plot of  $R_S$  vs Capacitive Load. However, this does not preserve signal integrity as well as a doubly-terminated line. If the input impedance of the destination device is low, there is some signal attenuation due to the voltage divider formed by the series output into the terminating impedance.

**e) Socketing a high-speed part like the OPA2613 is not recommended.** The additional lead length and pin-to-pin capacitance introduced by the socket can create an extremely troublesome parasitic network, which can make it almost impossible to achieve a smooth, stable frequency response. Best results are obtained by soldering the OPA2613 onto the board.

## INPUT AND ESD PROTECTION

The OPA2613 is built using a high-speed complementary bipolar process. The internal junction breakdown voltages are relatively low for these very small geometry devices and are reflected in the absolute maximum ratings table. All device pins have limited ESD protection using internal diodes to the power supplies, as shown in Figure 15.

These diodes provide moderate protection to input overdrive voltages above the supplies as well. The protection diodes can typically support 30mA continuous current. Where higher currents are possible (for example, in systems with  $\pm 15V$  supply parts driving into the OPA2613), current-limiting series resistors should be added into the two inputs. Keep these resistor values as low as possible, because high values degrade both noise performance and frequency response.

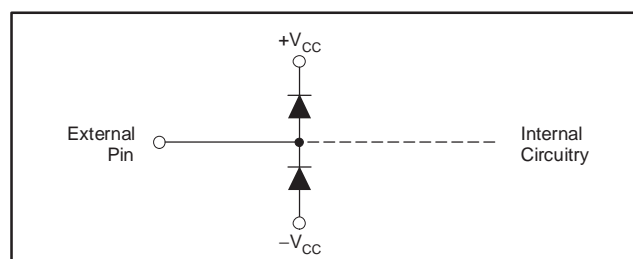



**Figure 15. Internal ESD Protection**

### Revision History

DATE	REV	PAGE	SECTION	DESCRIPTION
8/08	H	2	Absolute Maximum Ratings	Changed Storage Temperature minimum value from $-40^{\circ}\text{C}$ to $-65^{\circ}\text{C}$ .
9/07	G	—	—	Deleted all references to PSO-8 (OPA2613H) package.
		1	Description	Deleted last paragraph.
		25	Board Layout Guidelines	Deleted paragraph (F).

NOTE: Page numbers for previous revisions may differ from page numbers in the current version.

**PACKAGING INFORMATION**

Orderable Device	Status (1)	Package Type	Package Drawing	Pins	Package Qty	Eco Plan (2)	Lead finish/ Ball material (6)	MSL Peak Temp (3)	Op Temp (°C)	Device Marking (4/5)	Samples
OPA2613ID	ACTIVE	SOIC	D	8	75	RoHS & Green	NIPDAU	Level-2-260C-1 YEAR	-40 to 85	OPA 2613	
OPA2613IDR	ACTIVE	SOIC	D	8	2500	RoHS & Green	NIPDAU	Level-2-260C-1 YEAR	-40 to 85	OPA 2613	
OPA2613IDRG4	ACTIVE	SOIC	D	8	2500	RoHS & Green	NIPDAU	Level-2-260C-1 YEAR	-40 to 85	OPA 2613	

(1) The marketing status values are defined as follows:

**ACTIVE:** Product device recommended for new designs.

**LIFEBUY:** TI has announced that the device will be discontinued, and a lifetime-buy period is in effect.

**NRND:** Not recommended for new designs. Device is in production to support existing customers, but TI does not recommend using this part in a new design.

**PREVIEW:** Device has been announced but is not in production. Samples may or may not be available.

**OBSELETE:** TI has discontinued the production of the device.

(2) **RoHS:** TI defines "RoHS" to mean semiconductor products that are compliant with the current EU RoHS requirements for all 10 RoHS substances, including the requirement that RoHS substance do not exceed 0.1% by weight in homogeneous materials. Where designed to be soldered at high temperatures, "RoHS" products are suitable for use in specified lead-free processes. TI may reference these types of products as "Pb-Free".

**RoHS Exempt:** TI defines "RoHS Exempt" to mean products that contain lead but are compliant with EU RoHS pursuant to a specific EU RoHS exemption.

**Green:** TI defines "Green" to mean the content of Chlorine (Cl) and Bromine (Br) based flame retardants meet JS709B low halogen requirements of <=1000ppm threshold. Antimony trioxide based flame retardants must also meet the <=1000ppm threshold requirement.

(3) MSL, Peak Temp. - The Moisture Sensitivity Level rating according to the JEDEC industry standard classifications, and peak solder temperature.

(4) There may be additional marking, which relates to the logo, the lot trace code information, or the environmental category on the device.

(5) Multiple Device Markings will be inside parentheses. Only one Device Marking contained in parentheses and separated by a "~" will appear on a device. If a line is indented then it is a continuation of the previous line and the two combined represent the entire Device Marking for that device.

(6) Lead finish/Ball material - Orderable Devices may have multiple material finish options. Finish options are separated by a vertical ruled line. Lead finish/Ball material values may wrap to two lines if the finish value exceeds the maximum column width.

**Important Information and Disclaimer:**The information provided on this page represents TI's knowledge and belief as of the date that it is provided. TI bases its knowledge and belief on information provided by third parties, and makes no representation or warranty as to the accuracy of such information. Efforts are underway to better integrate information from third parties. TI has taken and continues to take reasonable steps to provide representative and accurate information but may not have conducted destructive testing or chemical analysis on incoming materials and chemicals. TI and TI suppliers consider certain information to be proprietary, and thus CAS numbers and other limited information may not be available for release.

In no event shall TI's liability arising out of such information exceed the total purchase price of the TI part(s) at issue in this document sold by TI to Customer on an annual basis.

**TAPE AND REEL INFORMATION**

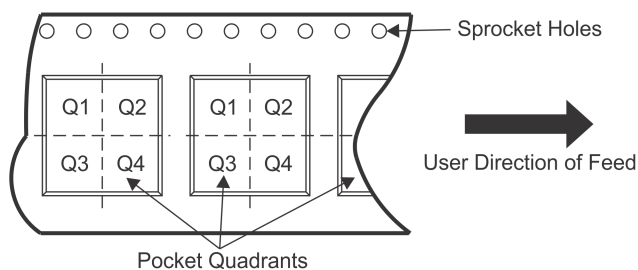
**QUADRANT ASSIGNMENTS FOR PIN 1 ORIENTATION IN TAPE**

\*All dimensions are nominal

Device	Package Type	Package Drawing	Pins	SPQ	Reel Diameter (mm)	Reel Width W1 (mm)	A0 (mm)	B0 (mm)	K0 (mm)	P1 (mm)	W (mm)	Pin1 Quadrant
OPA2613IDR	SOIC	D	8	2500	330.0	12.4	6.4	5.2	2.1	8.0	12.0	Q1

**TAPE AND REEL BOX DIMENSIONS**

\*All dimensions are nominal

Device	Package Type	Package Drawing	Pins	SPQ	Length (mm)	Width (mm)	Height (mm)
OPA2613IDR	SOIC	D	8	2500	853.0	449.0	35.0

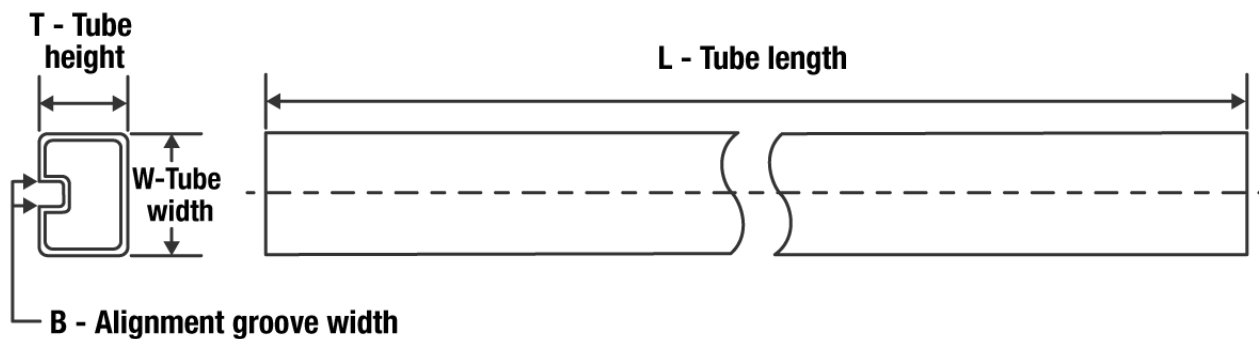
**TUBE**

\*All dimensions are nominal

Device	Package Name	Package Type	Pins	SPQ	L (mm)	W (mm)	T (μm)	B (mm)
OPA2613ID	D	SOIC	8	75	506.6	8	3940	4.32



D0008A

# PACKAGE OUTLINE

SOIC - 1.75 mm max height

SMALL OUTLINE INTEGRATED CIRCUIT



4214825/C 02/2019

NOTES:

- Linear dimensions are in inches [millimeters]. Dimensions in parenthesis are for reference only. Controlling dimensions are in inches. Dimensioning and tolerancing per ASME Y14.5M.
- This drawing is subject to change without notice.
- This dimension does not include mold flash, protrusions, or gate burrs. Mold flash, protrusions, or gate burrs shall not exceed .006 [0.15] per side.
- This dimension does not include interlead flash.
- Reference JEDEC registration MS-012, variation AA.

# EXAMPLE BOARD LAYOUT

D0008A

SOIC - 1.75 mm max height

SMALL OUTLINE INTEGRATED CIRCUIT



LAND PATTERN EXAMPLE  
 EXPOSED METAL SHOWN  
 SCALE:8X



SOLDER MASK DETAILS

4214825/C 02/2019

NOTES: (continued)

- 6. Publication IPC-7351 may have alternate designs.
- 7. Solder mask tolerances between and around signal pads can vary based on board fabrication site.

# EXAMPLE STENCIL DESIGN

D0008A

SOIC - 1.75 mm max height

SMALL OUTLINE INTEGRATED CIRCUIT



SOLDER PASTE EXAMPLE  
BASED ON .005 INCH [0.125 MM] THICK STENCIL  
SCALE:8X

4214825/C 02/2019

NOTES: (continued)

8. Laser cutting apertures with trapezoidal walls and rounded corners may offer better paste release. IPC-7525 may have alternate design recommendations.
9. Board assembly site may have different recommendations for stencil design.

## IMPORTANT NOTICE AND DISCLAIMER

TI PROVIDES TECHNICAL AND RELIABILITY DATA (INCLUDING DATA SHEETS), DESIGN RESOURCES (INCLUDING REFERENCE DESIGNS), APPLICATION OR OTHER DESIGN ADVICE, WEB TOOLS, SAFETY INFORMATION, AND OTHER RESOURCES "AS IS" AND WITH ALL FAULTS, AND DISCLAIMS ALL WARRANTIES, EXPRESS AND IMPLIED, INCLUDING WITHOUT LIMITATION ANY IMPLIED WARRANTIES OF MERCHANTABILITY, FITNESS FOR A PARTICULAR PURPOSE OR NON-INFRINGEMENT OF THIRD PARTY INTELLECTUAL PROPERTY RIGHTS.

These resources are intended for skilled developers designing with TI products. You are solely responsible for (1) selecting the appropriate TI products for your application, (2) designing, validating and testing your application, and (3) ensuring your application meets applicable standards, and any other safety, security, regulatory or other requirements.

These resources are subject to change without notice. TI grants you permission to use these resources only for development of an application that uses the TI products described in the resource. Other reproduction and display of these resources is prohibited. No license is granted to any other TI intellectual property right or to any third party intellectual property right. TI disclaims responsibility for, and you will fully indemnify TI and its representatives against, any claims, damages, costs, losses, and liabilities arising out of your use of these resources.

TI's products are provided subject to [TI's Terms of Sale](#) or other applicable terms available either on [ti.com](http://ti.com) or provided in conjunction with such TI products. TI's provision of these resources does not expand or otherwise alter TI's applicable warranties or warranty disclaimers for TI products.

TI objects to and rejects any additional or different terms you may have proposed.

Mailing Address: Texas Instruments, Post Office Box 655303, Dallas, Texas 75265  
Copyright © 2022, Texas Instruments Incorporated