

HIGH-SPEED RAIL-TO-RAIL OUTPUT VIDEO AMPLIFIERS

FEATURES

- High Speed
 - 100 MHz Bandwidth (–3 dB, G = 2)
 - 900 V/s Slew Rate
- Excellent Video Performance
 - 50 MHz Bandwidth (0.1 dB, G = 2)
 - 0.007% Differential Gain
 - 0.007 Differential Phase
- Rail-to-Rail Output Swing
 - $V_O = -4.5 / 4.5$ ($R_L = 150 \Omega$)
- High Output Drive, $I_O = 100$ mA (typ)
- Ultralow Distortion
 - HD2 = –78 dBc ($f = 5$ MHz, $R_L = 150 \Omega$)
 - HD3 = –85 dBc ($f = 5$ MHz, $R_L = 150 \Omega$)
- Wide Range of Power Supplies
 - $V_S = 3$ V to 15 V

APPLICATIONS

- Video Line Driver
- Imaging
- DVD / CD ROM
- Active Filtering
- General Purpose Signal Chain Conditioning

DESCRIPTION

The SN1050x family is a set of rail-to-rail output single, dual, and triple low-voltage, high-output swing, low-distortion high-speed amplifiers ideal for driving data converters, video switching, or low distortion applications. This family of voltage-feedback amplifiers can operate from a single 15-V power supply down to a single 3-V power supply while consuming only 14 mA of quiescent current per channel. In addition, the family offers excellent ac performance with 100-MHz bandwidth, 900-V/ μ s slew rate and harmonic distortion (THD) at –78 dBc at 5 MHz.

| DEVICE | DESCRIPTION |
|---------|-------------|
| SN10501 | Single |
| SN10502 | Dual |
| SN10503 | Triple |

VIDEO DRIVE CIRCUIT

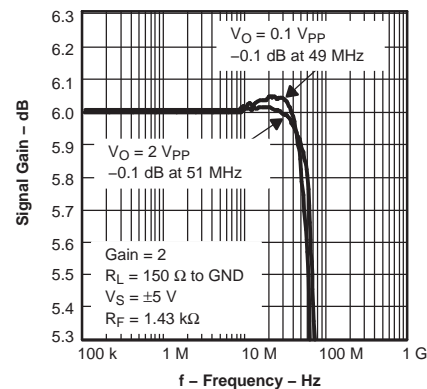
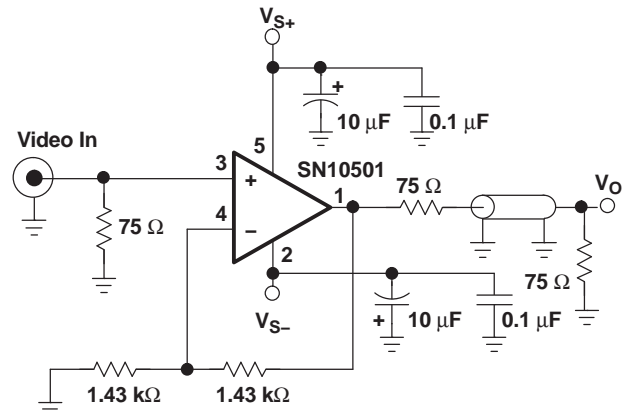

Please be aware that an important notice concerning availability, standard warranty, and use in critical applications of Texas Instruments semiconductor products and disclaimers thereto appears at the end of this data sheet.

PowerPAD is a trademark of Texas Instruments.



This integrated circuit can be damaged by ESD. Texas Instruments recommends that all integrated circuits be handled with appropriate precautions. Failure to observe proper handling and installation procedures can cause damage.

ESD damage can range from subtle performance degradation to complete device failure. Precision integrated circuits may be more susceptible to damage because very small parametric changes could cause the device not to meet its published specifications.

ABSOLUTE MAXIMUM RATINGS

operating free-air temperature range unless otherwise ⁽¹⁾

| | UNIT |
|---|----------------|
| Supply voltage, V_S | 16.5 V |
| Input voltage, V_I | $\pm V_S$ |
| Output current, I_O | 150 mA |
| Differential input voltage, V_{ID} | 4 V |
| Continuous power dissipation See Dissipation Rating Table | |
| Maximum junction temperature, T_J | 150°C |
| Maximum junction temperature, continuous operation, longterm reliability, $T_J^{(2)}$ | 125°C |
| Storage temperature range, T_{stg} | -65°C to 150°C |
| Lead temperature 1,6 mm (1/16 inch) from case for 10 seconds | 300°C |

- (1) The absolute maximum ratings under any condition is limited by the constraints of the silicon process. Stresses above these ratings may cause permanent damage. Exposure to absolute maximum conditions for extended periods may degrade device reliability. These are stress ratings only, and functional operation of the device at these or any other conditions beyond those specified is not implied.
- (2) The maximum junction temperature for continuous operation is limited by package constraints. Operation above this temperature may result in reduced reliability and/or lifetime of the device.

PACKAGE DISSIPATION RATINGS

| PACKAGE | $\theta_{JC} (^{\circ}C/W)^{(1)}$ | $\theta_{JA} (^{\circ}C/W)$ | POWER RATING ⁽²⁾ | |
|-------------------------|-----------------------------------|-----------------------------|-----------------------------|---------------------|
| | | | $T_A \leq 25^{\circ}C$ | $T_A = 85^{\circ}C$ |
| DBV (5) | 55 | 255.4 | 391 mW | 156 mW |
| D (8) | 38.3 | 97.5 | 1.02 W | 410 mW |
| D (14) | 26.9 | 66.6 | 1.5 W | 600 mW |
| DGK (8) | 54.2 | 260 | 385 mW | 154 mW |
| DGN (8) ⁽³⁾ | 4.7 | 58.4 | 1.71 W | 685 mW |
| PWP (14) ⁽³⁾ | 2.07 | 37.5 | 2.67 W | 1.07 W |

- (1) This data was taken using the JEDEC standard High-K test PCB.
- (2) Power rating is determined with a junction temperature of 125°C. This is the point where distortion starts to substantially increase. Thermal management of the final PCB should strive to keep the junction temperature at or below 125°C for best performance and long term reliability.
- (3) The SN10501, SN10502, and SN10503 may incorporate a PowerPAD™ on the underside of the chip. This acts as a heatsink and must be connected to a thermally dissipating plane for proper power dissipation. Failure to do so may result in exceeding the maximum junction temperature which could permanently damage the device. See TI Technical Brief [SLMA002](#) for more information about utilizing the PowerPAD™ thermally enhanced package.

RECOMMENDED OPERATING CONDITIONS

| | | MIN | MAX | UNIT |
|--|---------------|-----------------------|-----------------------|------|
| Supply voltage, (V _{S+} and V _{S-}) | Dual supply | 1.35 | 8 | V |
| | Single supply | 2.7 | 16 | |
| Input common-mode voltage range | | V _{S-} + 1.1 | V _{S+} - 1.1 | V |

PACKAGE ORDERING INFORMATION

| PACKAGED DEVICES | | | PACKAGE TYPE | TRANSPORT MEDIA, QUANTITY |
|------------------|-------------|-------------|--------------|---------------------------|
| SINGLE | DUAL | TRIPLE | | |
| SN10501DBVT | — | — | SOT-23-5 | Tape and Reel, 250 |
| SN10501DBVR | — | — | SOT-23-5 | Tape and Reel, 3000 |
| SN10501DGK | SN10502DGK | — | MSOP-8 | Rails, 75 |
| SN10501DGKR | SN10502DGKR | — | MSOP-8 | Tape and Reel, 2500 |
| SN10501DGN | SN10502DGN | — | MSOP-8-PP | Rails, 75 |
| SN10501DGNR | SN10502DGNR | — | MSOP-8-PP | Tape and Reel, 2500 |
| SN10501D | SN10502D | SN10503D | SOIC | Rails, 75 |
| SN10501DR | SN10502DR | SN10503DR | SOIC | Tape and Reel, 2500 |
| — | — | SN10503PWP | TSSOP-14-PP | Rails, 75 |
| — | — | SN10503PWPR | TSSOP-14-PP | Tape and Reel, 2000 |

PIN ASSIGNMENTS

PACKAGE DEVICES

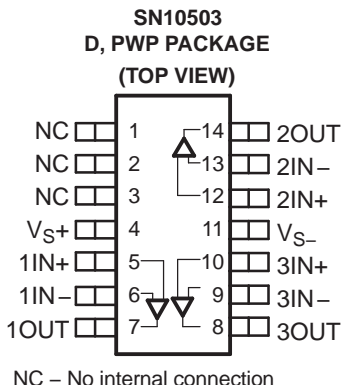
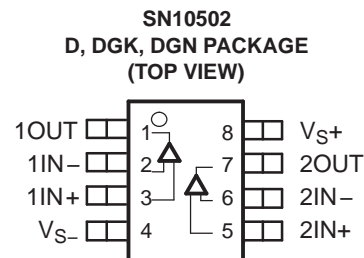
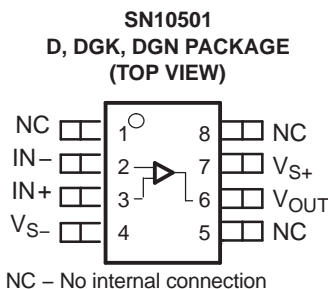
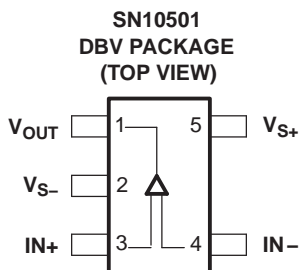

ELECTRICAL CHARACTERISTICS

$V_S = 5\text{ V}$, $R_L = 150\ \Omega$, and $G = 2$ unless otherwise noted

| PARAMETER | TEST CONDITIONS | TYP | OVER TEMPERATURE | | | | UNITS | MIN/MAX |
|--------------------------------------|---|------------|------------------|-------------|---------------|--|------------------------|---------|
| | | 25°C | 25°C | 0°C to 70°C | -40°C to 85°C | | | |
| AC PERFORMANCE | | | | | | | | |
| Small signal bandwidth | $G = 1, V_O = 100\text{ mV}_{PP}$ | 170 | | | | | MHz | Typ |
| | $G = 2, V_O = 100\text{ mV}_{PP}, R_f = 1\text{ k}\Omega$ | 100 | | | | | MHz | Typ |
| | $G = 10, V_O = 100\text{ mV}_{PP}, R_f = 1\text{ k}\Omega$ | 12 | | | | | MHz | Typ |
| 0.1 dB flat bandwidth | $G = 2, V_O = 100\text{ mV}_{PP}, R_f = 1.43\text{ k}\Omega$ | 50 | | | | | MHz | Typ |
| Gain bandwidth product | $G > 10, f = 1\text{ MHz}, R_f = 1\text{ k}\Omega$ | 120 | | | | | MHz | Typ |
| Full-power bandwidth ⁽¹⁾ | $G = 2, V_O = \pm 2.5\text{ V}_{PP}$ | 57 | | | | | MHz | Typ |
| Slew rate | $G = 2, V_O = \pm 2.5\text{ V}_{PP}$ | 900 | | | | | V/ μ s | Min |
| Settling time to 0.1% | $G = -2, V_O = \pm 2\text{ V}_{PP}$ | 25 | | | | | ns | Typ |
| Settling time to 0.01% | | 52 | | | | | ns | Typ |
| Harmonic distortion | | | | | | | | |
| Second harmonic distortion | $G = 2, V_O = 2\text{ V}_{PP}, f = 5\text{ MHz}, R_L = 150\ \Omega$ | -78 | | | | | dBc | Typ |
| Third harmonic distortion | | -85 | | | | | dBc | Typ |
| Differential gain (NTSC, PAL) | $G = 2, R = 150\ \Omega$ | 0.007 | | | | | % | Typ |
| Differential phase (NTSC, PAL) | | 0.007 | | | | | ° | Typ |
| Input voltage noise | $f = 1\text{ MHz}$ | 13 | | | | | nV/ $\sqrt{\text{Hz}}$ | Typ |
| Input current noise | | 0.8 | | | | | pA/ $\sqrt{\text{Hz}}$ | Typ |
| Crosstalk (dual and triple only) | $f = 5\text{ MHz Ch-to-Ch}$ | -90 | | | | | dB | Typ |
| DC PERFORMANCE | | | | | | | | |
| Open-loop voltage gain (A_{OL}) | $V_O = \pm 2\text{ V}$ | 100 | 80 | 75 | 75 | | dB | Min |
| Input offset voltage | $V_{CM} = 0\text{ V}$ | 12 | 25 | 30 | 30 | | mV | Max |
| Input bias current | | 0.9 | 3 | 5 | 5 | | μ A | Max |
| Input offset current | | 100 | 500 | 700 | 700 | | nA | Max |
| INPUT CHARACTERISTICS | | | | | | | | |
| Common-mode input range | | -4 / 4 | -3.9 / 3.9 | | | | V | Min |
| Common-mode rejection ratio | $V_{CM} = 2\text{ V}$ | 94 | 70 | 65 | 65 | | dB | Min |
| Input resistance | | 33 | | | | | M Ω | Typ |
| Input capacitance | Common-mode / differential | 1 / 0.5 | | | | | pF | Max |
| OUTPUT CHARACTERISTICS | | | | | | | | |
| Output voltage swing | $R_L = 150\ \Omega$ | -4.5 / 4.5 | | | | | V | Typ |
| | $R_L = 499\ \Omega$ | -4.7 / 4.7 | -4.5 / 4.5 | -4.4 / 4.4 | -4.4 / 4.4 | | V | Min |
| Output current (sourcing) | $R_L = 10\ \Omega$ | 100 | 92 | 88 | 88 | | mA | Min |
| Output current (sinking) | | -100 | -92 | -88 | -88 | | mA | Min |
| Output impedance | $f = 1\text{ MHz}$ | 0.09 | | | | | Ω | Typ |
| POWER SUPPLY | | | | | | | | |
| Specified operating voltage | | ± 5 | ± 8 | ± 8 | ± 8 | | V | Max |
| Maximum quiescent current | Per channel | 14 | 18 | 20 | 22 | | mA | Max |
| Power supply rejection (\pm PSRR) | | 75 | 62 | 60 | 60 | | dB | Min |

(1) Full-power bandwidth = $SR / 2\pi V_{pp}$

ELECTRICAL CHARACTERISTICS

 $V_S = 5\text{ V}$, $R_L = 150\ \Omega$, and $G = 2$ unless otherwise noted

| PARAMETER | TEST CONDITIONS | TYP | OVER TEMPERATURE | | | | UNITS | MIN/MAX |
|--------------------------------------|---|-----------|------------------|------------|--------------|--|------------------------|---------|
| | | 25°C | 25°C | 0°C to 70C | -40°C to 85C | | | |
| AC PERFORMANCE | | | | | | | | |
| Small signal bandwidth | $G = 1$, $V_O = 100\text{ mV}_{PP}$ | 170 | | | | | MHz | Typ |
| | $G = 2$, $V_O = 100\text{ mV}_{PP}$, $R_f = 1.5\text{ k}\Omega$ | 100 | | | | | MHz | Typ |
| | $G = 10$, $V_O = 100\text{ mV}_{PP}$, $R_f = 1.5\text{ k}\Omega$ | 12 | | | | | MHz | Typ |
| 0.1 dB flat bandwidth | $G = 2$, $V_O = 100\text{ mV}_{PP}$, $R_f = 1.24\text{ k}\Omega$ | 50 | | | | | MHz | Typ |
| Gain bandwidth product | $G > 10$, $f = 1\text{ MHz}$, $R_f = 1.5\text{ k}\Omega$ | 120 | | | | | MHz | Typ |
| Full-power bandwidth ⁽¹⁾ | $G = 2$, $V_O = 4\text{ V}$ step | 60 | | | | | MHz | Typ |
| Slew rate | | 750 | | | | | V/ μ s | Min |
| Settling time to 0.1% | $G = -2$, $V_O = 2\text{ V}$ | 27 | | | | | ns | Typ |
| Settling time to 0.01% | | 48 | | | | | ns | Typ |
| Harmonic distortion | | | | | | | | |
| Second harmonic distortion | $G = 2$, $V_O = 2\text{ V}_{PP}$, $f = 5\text{ MHz}$, $R_L = 150\ \Omega$ | -82 | | | | | dBc | Typ |
| Third harmonic distortion | | -88 | | | | | dBc | Typ |
| Differential gain (NTSC, PAL) | $G = 2$, $R = 150\ \Omega$ | 0.014 | | | | | % | Typ |
| Differential phase (NTSC, PAL) | | 0.011 | | | | | ° | Typ |
| Input voltage noise | $f = 1\text{ MHz}$ | 13 | | | | | nV/ $\sqrt{\text{Hz}}$ | Typ |
| Input current noise | | 0.8 | | | | | pA/ $\sqrt{\text{Hz}}$ | Typ |
| Crosstalk (dual and triple only) | $f = 5\text{ MHz}$ Ch-to-Ch | -90 | | | | | dB | Typ |
| DC PERFORMANCE | | | | | | | | |
| Open-loop voltage gain (A_{OL}) | $V_O = 1.5\text{ V}$ to 3.5 V | 100 | 80 | 75 | 75 | | dB | Min |
| Input offset voltage | $V_{CM} = 2.5\text{ V}$ | 12 | 25 | 30 | 30 | | mV | Max |
| Input bias current | | 0.9 | 3 | 5 | 5 | | μ A | Max |
| Input offset current | | 100 | 500 | 700 | 700 | | nA | Max |
| INPUT CHARACTERISTICS | | | | | | | | |
| Common-mode input range | | 1 / 4 | 1.1 / 3.9 | | | | V | Min |
| Common-mode rejection ratio | $V_{CM} = 1.5\text{ V}$ to 3.5 V | 96 | 70 | 65 | 65 | | dB | Min |
| Input resistance | | 33 | | | | | M Ω | Typ |
| Input capacitance | Common-mode / differential | 1 / 0.5 | | | | | pF | Max |
| OUTPUT CHARACTERISTICS | | | | | | | | |
| Output voltage swing | $R_L = 150\ \Omega$ | 0.5 / 4.5 | | | | | V | Typ |
| | $R_L = 499\ \Omega$ | 0.2 / 4.8 | 0.3 / 4.7 | 0.4 / 4.6 | 0.4 / 4.6 | | V | Min |
| Output current (sourcing) | $R_L = 10\ \Omega$ | 95 | 85 | 80 | 80 | | mA | Min |
| Output current (sinking) | | -95 | -85 | -80 | -80 | | mA | Min |
| Output impedance | $f = 1\text{ MHz}$ | 0.09 | | | | | Ω | Typ |
| POWER SUPPLY | | | | | | | | |
| Specified operating voltage | | 5 | 16 | 16 | 16 | | V | Max |
| Maximum quiescent current | Per channel | 12 | 15 | 17 | 19 | | mA | Max |
| Power supply rejection (\pm PSRR) | | 70 | 62 | 60 | 60 | | dB | Min |

 (1) Full-power bandwidth = $SR / 2\pi V_{pp}$

TYPICAL CHARACTERISTICS

TABLE OF GRAPHS

| | | FIGURE |
|---------------------------------|----------------------------|--------|
| Frequency response | | 1– 8 |
| Small signal frequency response | | 9, 10 |
| Large signal frequency response | | 11 |
| Slew rate | vs Output voltage step | 12, 13 |
| Harmonic distortion | vs Frequency | 14, 15 |
| Voltage and current noise | vs Frequency | 16 |
| Differential gain | vs Number of loads | 17, 18 |
| Differential phase | vs Number of loads | 19, 20 |
| Quiescent current | vs Supply voltage | 21 |
| Output voltage | vs Load resistance | 22 |
| Open-loop gain and phase | vs Frequency | 23 |
| Rejection ratio | vs Frequency | 24 |
| Rejection ratio | vs Case temperature | 25 |
| Common-mode rejection ratio | vs Input common-mode range | 26, 27 |
| Output impedance | vs Frequency | 28, 29 |
| Crosstalk | vs Frequency | 30 |
| Input bias and offset current | vs Case temperature | 31, 32 |

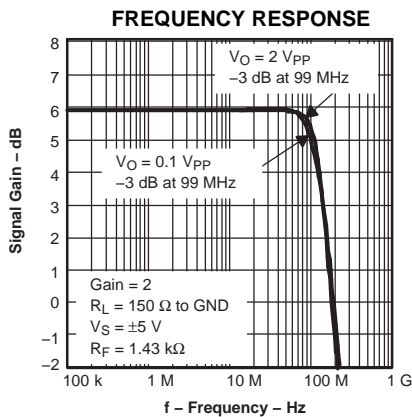

Figure 1.

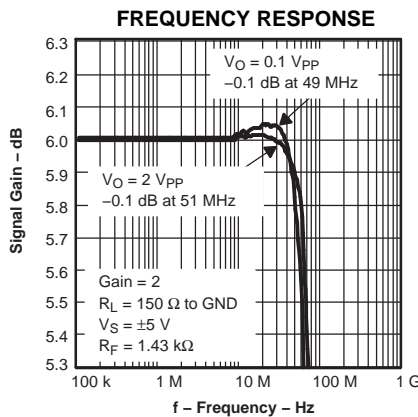

Figure 2.

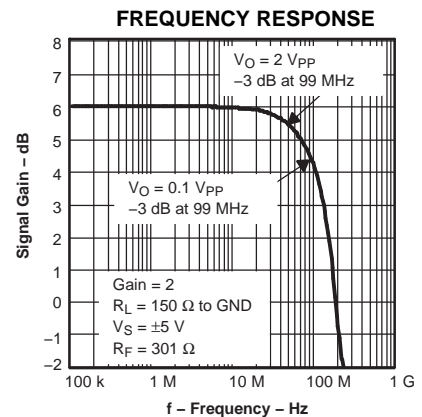

Figure 3.

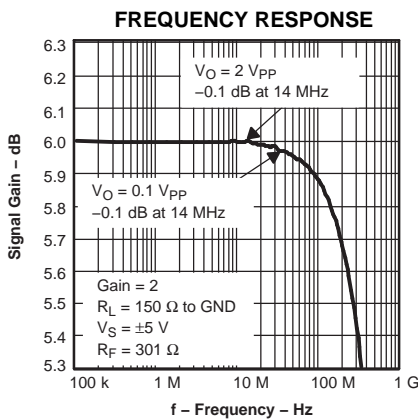

Figure 4.

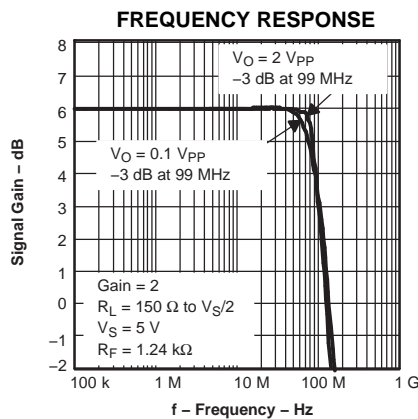

Figure 5.

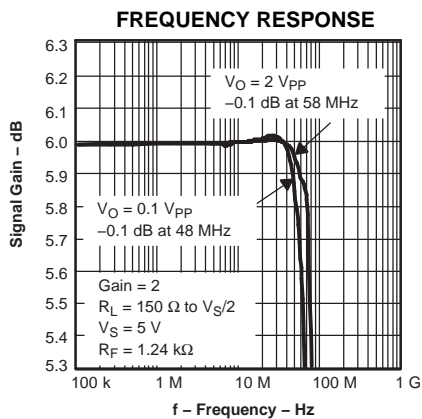

Figure 6.

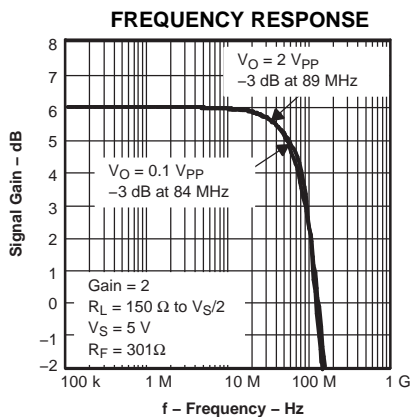

Figure 7.

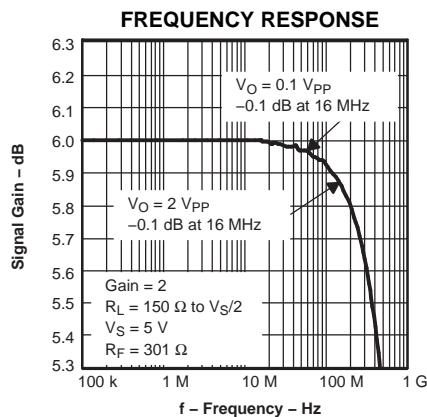

Figure 8.

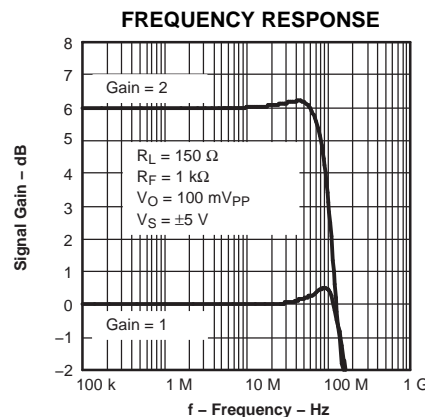

Figure 9.

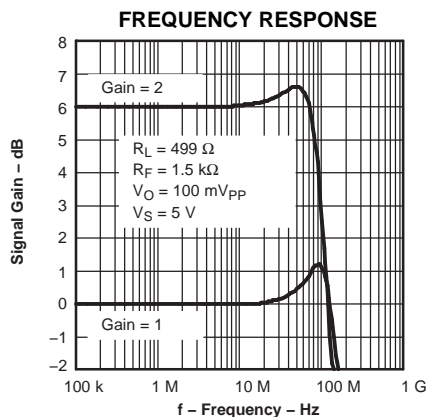

Figure 10.

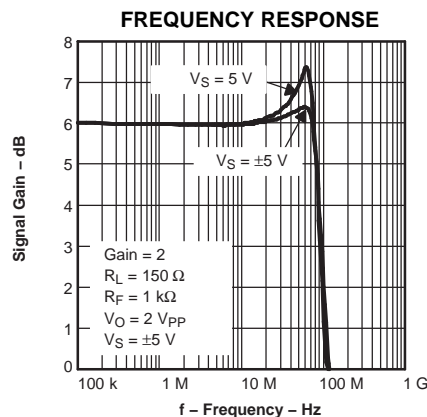

Figure 11.

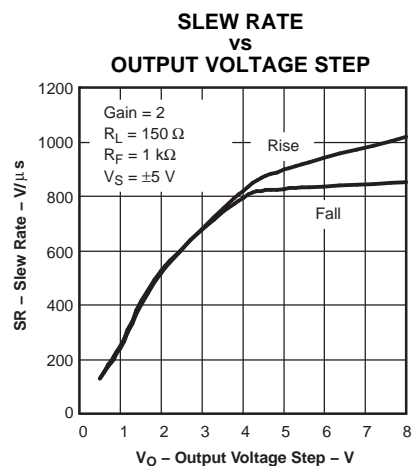

Figure 12.

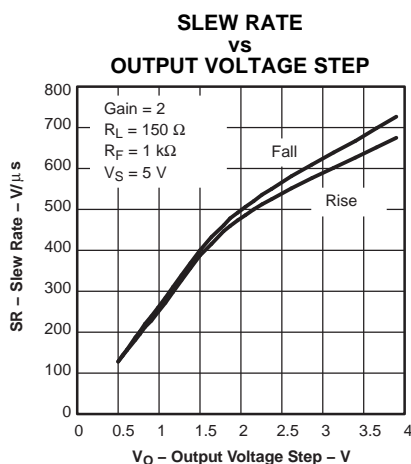

Figure 13.

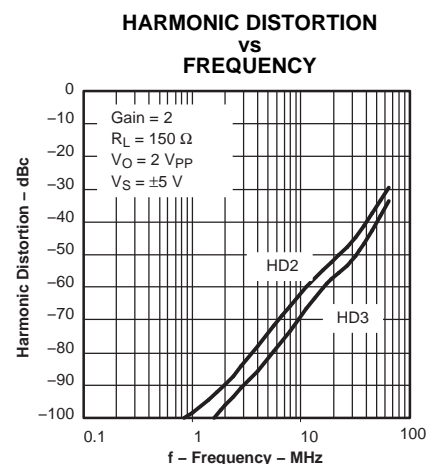

Figure 14.

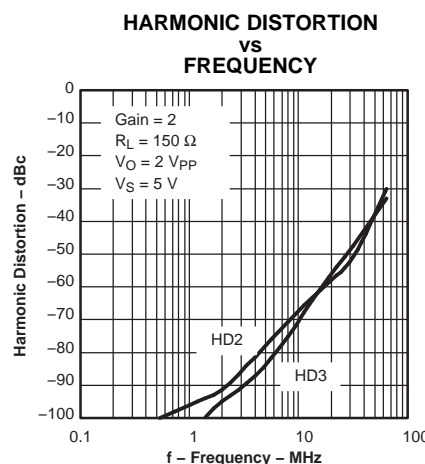

Figure 15.

**VOLTAGE AND CURRENT NOISE
VS
FREQUENCY**

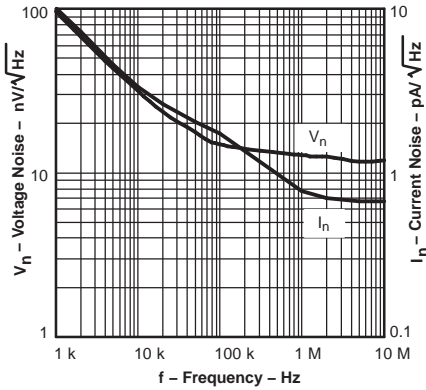

Figure 16.

**DIFFERENTIAL GAIN
VS
NUMBER OF LOADS**

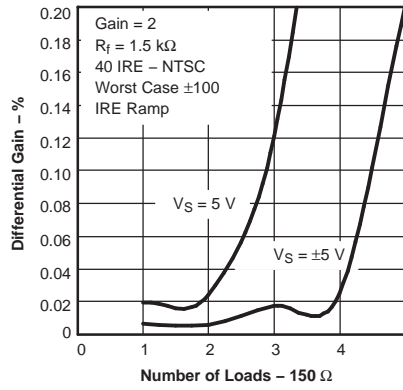

Figure 17.

**DIFFERENTIAL PHASE
VS
NUMBER OF LOADS**

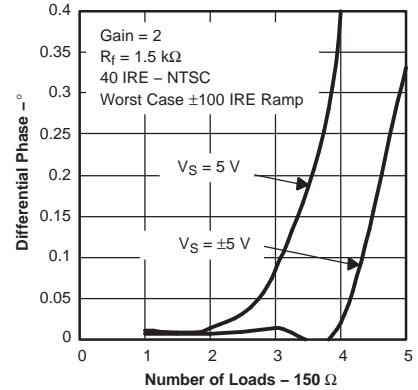

Figure 18.

**DIFFERENTIAL GAIN
VS
NUMBER OF LOADS**

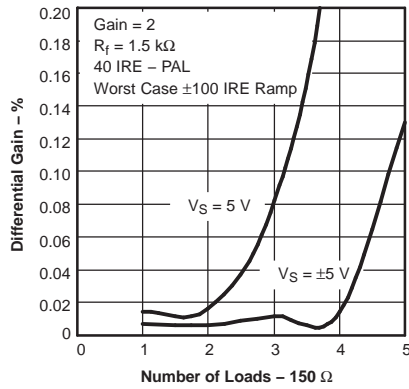

Figure 19.

**DIFFERENTIAL PHASE
VS
NUMBER OF LOADS**

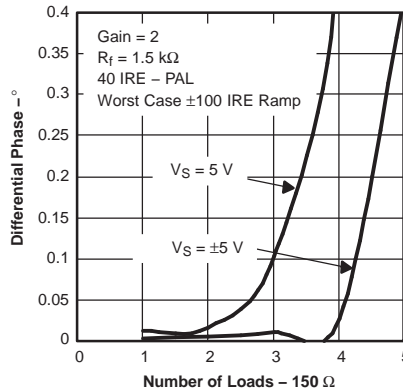

Figure 20.

**QUIESCENT CURRENT
VS
SUPPLY VOLTAGE**

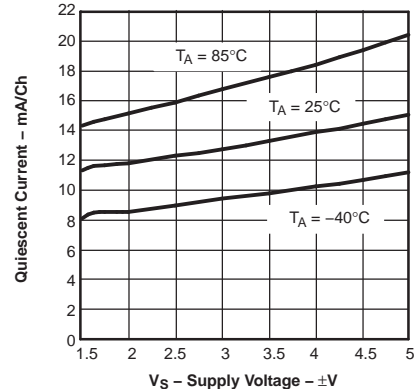

Figure 21.

**OUTPUT VOLTAGE
VS
LOAD RESISTANCE**

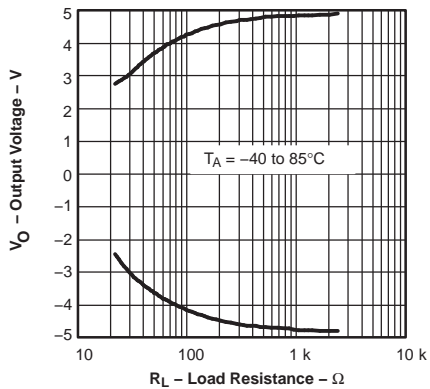

Figure 22.

**OPEN-LOOP GAIN AND PHASE
VS
FREQUENCY**

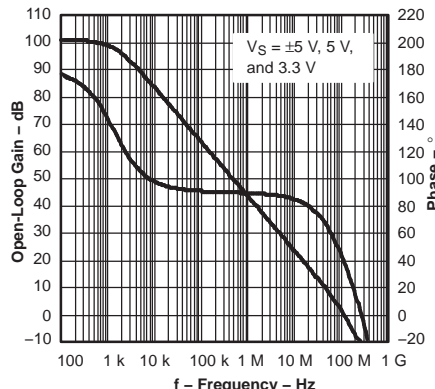

Figure 23.

**REJECTION RATIO
VS
FREQUENCY**

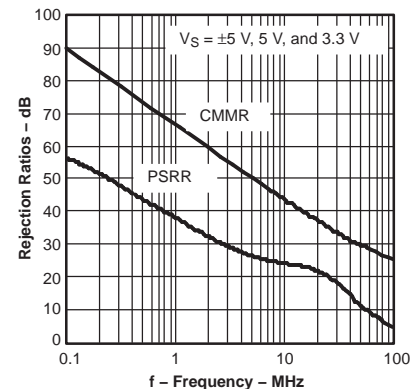

Figure 24.

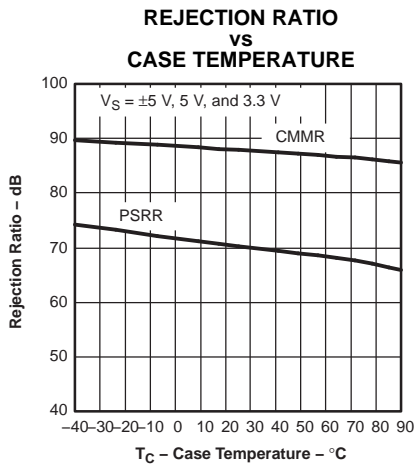

Figure 25.

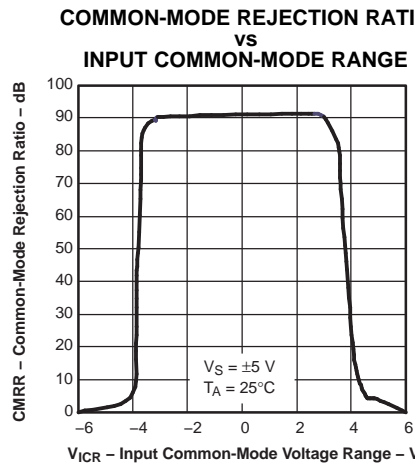

Figure 26.

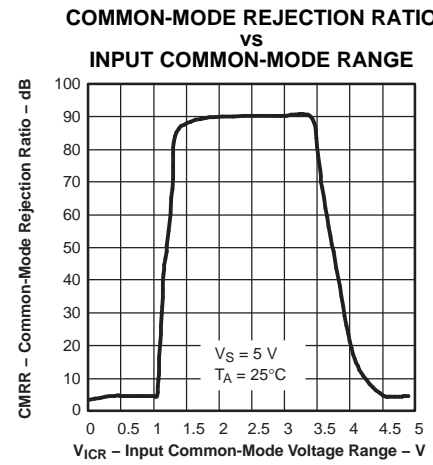

Figure 27.

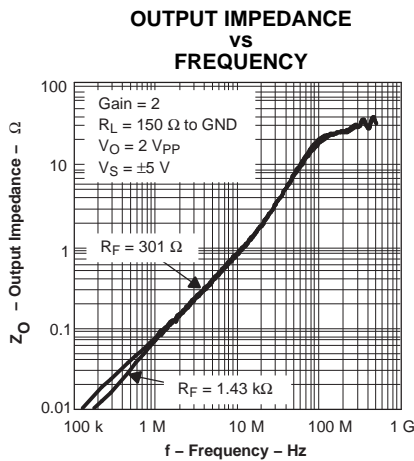

Figure 28.

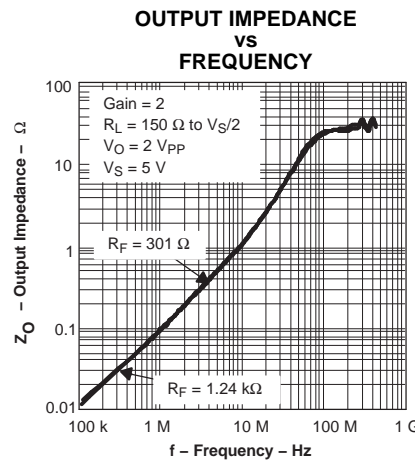

Figure 29.

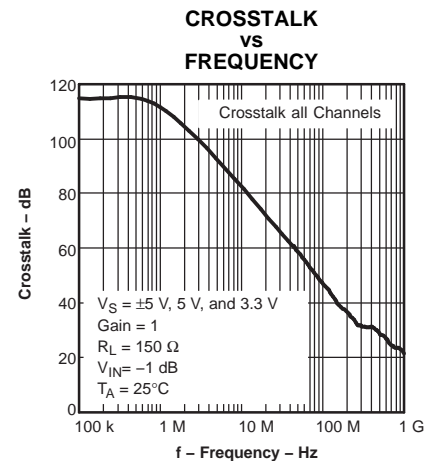

Figure 30.

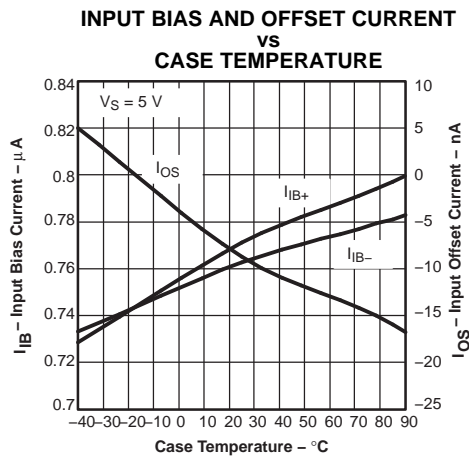

Figure 31.

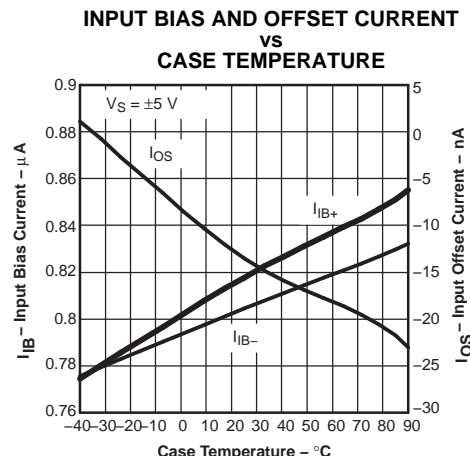

Figure 32.

APPLICATION INFORMATION

HIGH-SPEED OPERATIONAL AMPLIFIERS

The SN1050x operational amplifiers are a family of single, dual, and triple rail-to-rail output voltage feedback amplifiers. The SN1050x family combines both a high slew rate and a rail-to-rail output stage.

Applications Section Contents

- Wideband, Noninverting Operation
- Wideband, Inverting Gain Operation
- Video Drive Circuits
- Single Supply Operation
- Power Supply Decoupling Techniques and Recommendations
- Active Filtering With the SN1050x
- Driving Capacitive Loads
- Board Layout
- Thermal Analysis
- Additional Reference Material
- Mechanical Package Drawings

WIDEBAND, NONINVERTING OPERATION

The SN1050x is a family of unity gain stable rail-to-rail output voltage feedback operational amplifiers designed to operate from a single 3-V to 15-V power supply.

Figure 33 is the noninverting gain configuration of 2V/V used to demonstrate the typical performance curves.

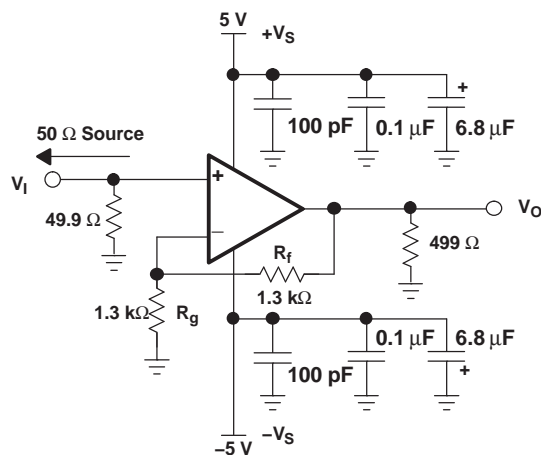

Figure 33. Wideband, Noninverting Gain Configuration

Voltage-feedback amplifiers, unlike current-feedback designs, can use a wide range of resistor values to set their gain with minimal impact on their stability and frequency response. Larger-valued resistors

decrease the loading effect of the feedback network on the output of the amplifier, but this enhancement comes at the expense of additional noise and potentially lower bandwidth. Feedback-resistor values between 1 k Ω and 2 k Ω are recommended for most situations.

WIDEBAND, INVERTING OPERATION

Since the SN1050x family are general-purpose, wideband voltage-feedback amplifiers, several familiar operational-amplifier applications circuits are available to the designer. Figure 34 shows a typical inverting configuration where the input and output impedances and noise gain from Figure 33 are retained in an inverting circuit configuration. Inverting operation is one of the more common requirements and offers several performance benefits. The inverting configuration shows improved slew rates and distortion due to the pseudo-static voltage maintained on the inverting input.

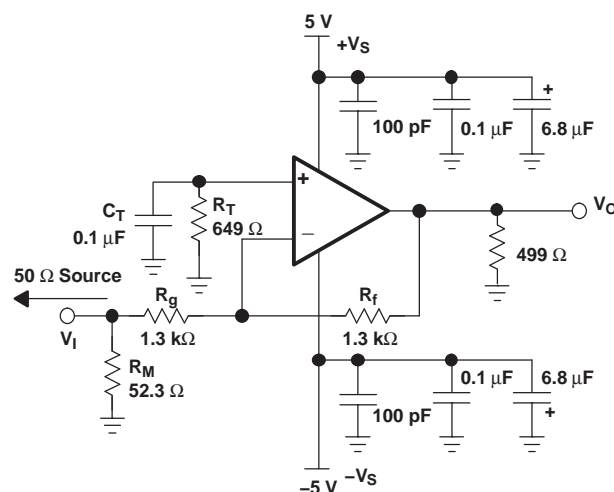

Figure 34. Wideband, Inverting Gain Configuration

In the inverting configuration, some key design considerations must be noted. One is that the gain resistor (R_g) becomes part of the signal channel input impedance. If input impedance matching is desired (beneficial when the signal is coupled through a cable, twisted pair, long PC-board trace, or other transmission-line conductors), R_g may be set equal to the required termination value and R_f adjusted to give the desired gain. However, care must be taken when dealing with low inverting gains, because the resulting feedback-resistor value can present a significant load to the amplifier output. For an inverting gain of 2, setting R_g to 49.9 Ω for input matching eliminates the need for R_M but requires a 100- Ω feedback resistor. This has the advantage that the noise gain becomes equal to 2 for a 50- Ω source impedance—the same

as the noninverting circuit in Figure 33. However, the amplifier output now sees the 100-Ω feedback resistor in parallel with the external load. To eliminate this excessive loading, increase both R_g and R_f values, as shown in Figure 34, and then provide the input-matching impedance with a third resistor (R_M) to ground. The total input impedance becomes the parallel combination of R_g and R_M .

The last major consideration to discuss in inverting amplifier design is setting the bias-current cancellation resistor on the noninverting input. If the resistance is set equal to the total dc resistance looking out of the inverting terminal, the output dc error, due to the input bias currents, is reduced to the input-offset current multiplied by R_f in Figure 34. The dc source impedance looking out of the inverting terminal is $1.3 \text{ k}\Omega \parallel (1.3 \text{ k}\Omega + 25.6 \text{ }\Omega) = 649 \text{ }\Omega$. To reduce the additional high-frequency noise introduced by the resistor at the noninverting input, and power-supply feedback, R_T is bypassed with a capacitor to ground.

SINGLE SUPPLY OPERATION

The SN1050x family is designed to operate from a single 3-V to 15-V power supply. When operating from a single power supply, care must be taken to ensure that the input signal and amplifier are biased appropriately to allow for the maximum output voltage swing. The circuits shown in Figure 35 demonstrate methods to configure an amplifier for single-supply operation.

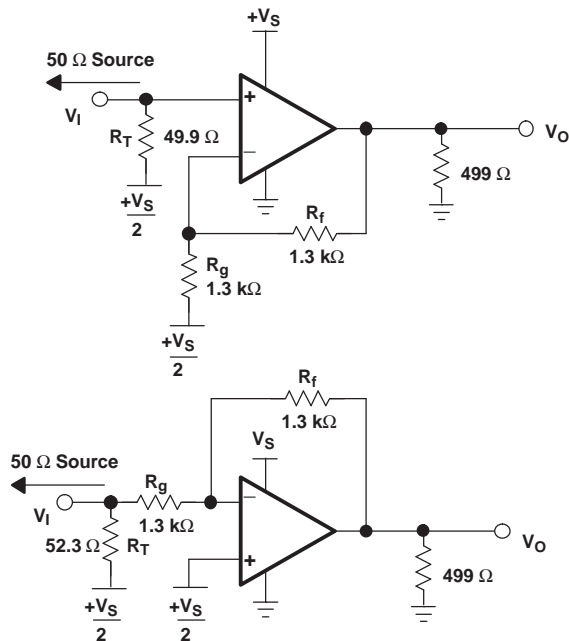

Figure 35. DC-Coupled Single Supply Operation

Video Drive Circuits

Most video-distribution systems are designed with 75-Ω series resistors to drive a matched 75-Ω cable. In order to deliver a net gain of 1 to the 75-Ω matched load, the amplifier is typically set up for a voltage gain of 2, compensating for the 6-dB attenuation of the voltage divider formed by the series and shunt 75-Ω resistors at either end of the cable. The circuit shown in Figure 36 meets this requirement. The SN1050x gain flatness and differential gain/phase performance provide exceptional results in video distribution applications.

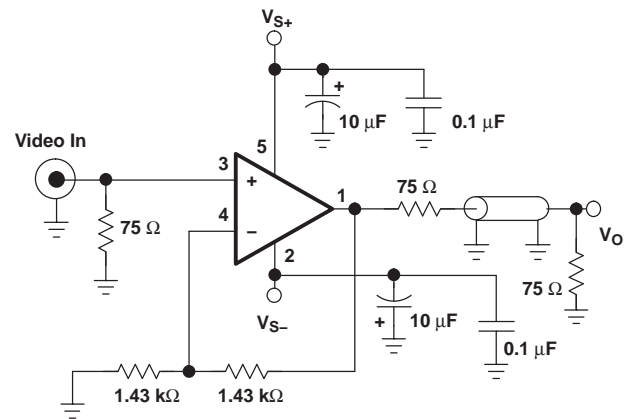

Figure 36. Cable Drive Application

Differential gain and phase measure the change in overall small-signal gain and phase for the color subcarrier frequency (3.58 MHz in NTSC systems) vs changes in the large-signal output level (which represents luminance information in a composite video signal). The SN1050x, with the typical 150-Ω load of a single matched video cable, shows less than 0.007% / 0.007° differential gain/phase errors over the standard luminance range for a positive video (negative sync) signal.

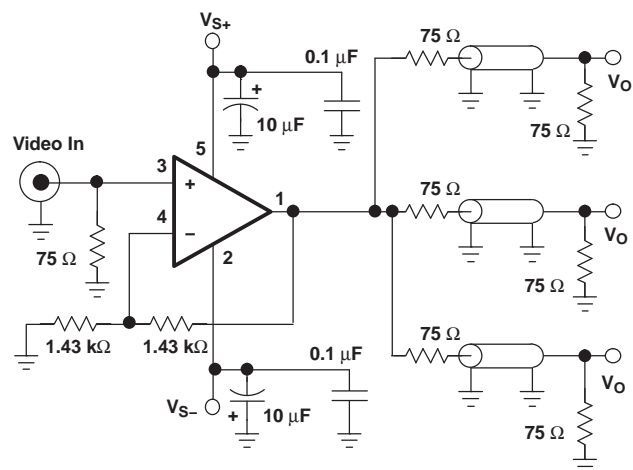

Figure 37. Video Distribution

Similar performance is observed for negative video signals. In practice, similar performance is achieved even with three video loads as shown in Figure 37 due to the linear high-frequency output impedance of the SN1050x. This circuit is suitable for driving video cables, provided that the length does not exceed a few feet. If longer cables are driven, the gain of the SN1050x can be increased to compensate for cable loss.

Configuring the SN1050x for single-supply video applications is easily done, but attention must be given to input and output bias voltages to ensure proper system operation. Unlike some video amplifiers, the SN1050x input common-mode voltage range does not include the negative power supply, but rather it is about 1-V from each power supply. For split supply configurations, this is very beneficial. For single-supply systems, there are some design constraints that must be observed.

Figure 38 shows a single-supply video configuration illustrating the dc bias voltages acceptable for the SN1050x. The lower end of the input common-mode range is specified as 1 V. The upper end is limited to 4 V with the 5-V supply shown, but the output range and gain of 2 limit the highest acceptable input voltage to $4.5 \text{ V} / 2 = 2.25 \text{ V}$. The 4.5-V output is what is typically expected with a 150- Ω load. It is easily seen that the input and output voltage ranges are limiting factors in the total system. Both specifications must be taken into account when designing a system.

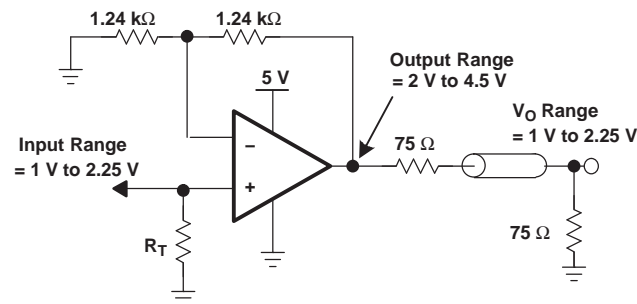

Figure 38. DC-Coupled Single-Supply Video Amplifier

In most systems, this may be acceptable because most receivers are ac-coupled and set the black level to the desired system value, typically 0 V (0-IRE). But, to ensure full compatibility with any system, it is often desirable to place an ac coupling capacitor on the output as shown in Figure 39. This removes the dc-bias voltage appearing at the amplifier output. To minimize field tilt, the size of this capacitor is typically 470 μF , although values as small as 220 μF have been used with acceptable results.

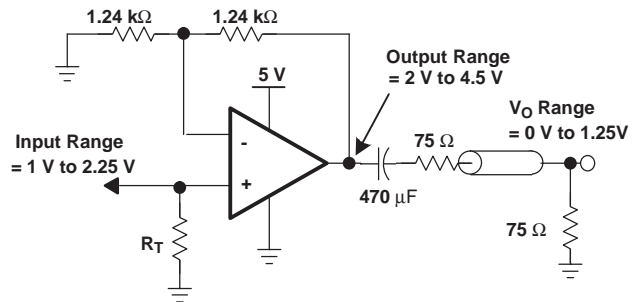

Figure 39. AC-Coupled Output Single-Supply Video Amplifier

In some systems, the physical size and/or cost of a 470- μF capacitor can be prohibitive. One way to circumvent this issue is to use two smaller capacitors in a feedback configuration as shown in Figure 40. This is commonly known as SAG correction. This circuit increases the gain of the amplifier up to 3 V/V at low frequencies to counteract the increased impedance of the capacitor placed at the amplifier output. One issue that must be resolved is that the gain at low frequencies is typically limited by the power-supply voltage and the output swing of the amplifier. Therefore, it is possible to saturate the amplifier at these low frequencies if full analysis is not done on this system which includes both input and output requirements.

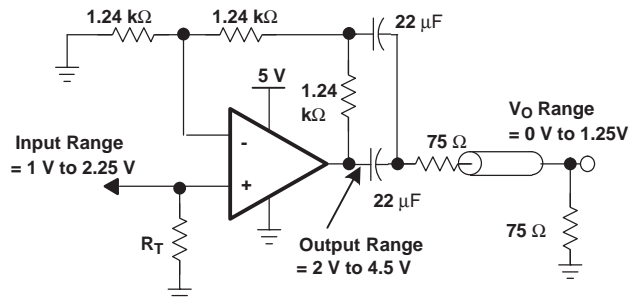

Figure 40. AC-Coupled SAG Corrected Output Single-Supply Video Amplifier

Many times the output of the video encoder or DAC does not have the capability to output the 1-V to 2.25-V range, but rather a 0-V to 1.25-V range. In this instance, the signal must be ac-coupled to the amplifier input as shown in Figure 41. Note that it does not matter what the voltage output of the DAC is, but rather the voltage swing should be kept less than $1.25 \text{ V}_{\text{PP}}$.

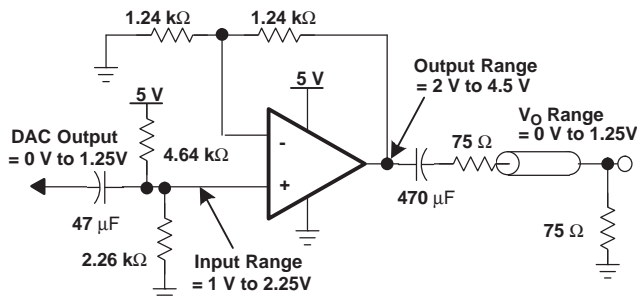

Figure 41. AC-Coupled Input and Output Single-Supply Video Amplifier

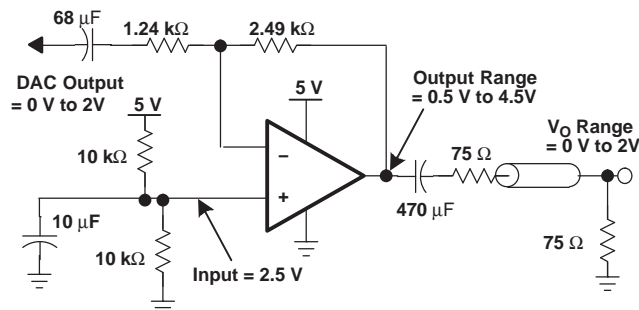

Figure 44. Inverting AC-Coupled Wide Output Swing Single-Supply Video Amplifier

To further increase dynamic range at the output, the output dc bias should be centered around 2.5 V for the 5-V system shown. However, a wide output range requires a wide input range, and should be centered around 2.5 V. The best ways to accomplish this are to ac-couple the gain resistor or bias it at 2.5 V with a reference supply as shown in Figure 42 and Figure 43.

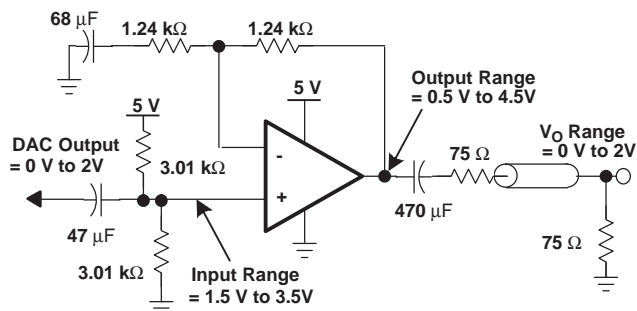

Figure 42. AC-Coupled Wide Output Swing Single-Supply Video Amplifier

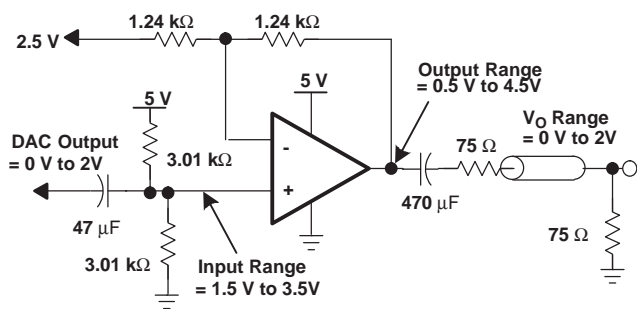

Figure 43. AC-Coupled Wide Output Swing Single-Supply Video Amplifier Using Voltage Reference

Another beneficial configuration is to use the amplifier in an inverting configuration as shown in Figure 44.

APPLICATION CIRCUITS

Active Filtering With the SN1050x

High-frequency active filtering with the SN1050x is achievable due to the amplifier's high slew rate, wide bandwidth, and voltage feedback architecture. Several options are available for high-pass, low-pass, bandpass, and bandstop filters of varying orders. A simple two-pole, low-pass filter is presented in Figure 45 as an example, with two poles at 25 MHz.

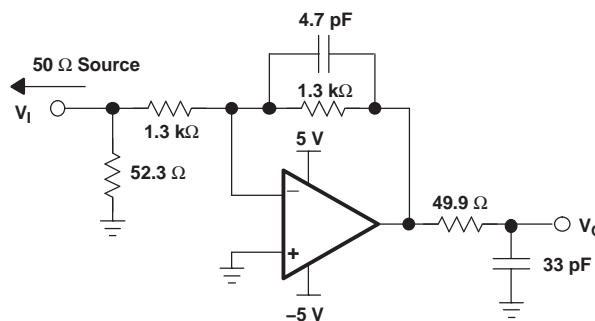

Figure 45. A Two-Pole Active Filter With Two Poles Between 90 MHz and 100 MHz

Driving Capacitive Loads

A demanding, yet very common application for an op amp is capacitive loading. Often, this load is the input of an A/D converter, including additional external capacitance, sometimes recommended to improve A/D linearity. A high-speed, high open-loop gain amplifier like the SN1050x can be very susceptible to decreased stability and closed-loop response peaking when a capacitive load is placed directly on the output pin. When the amplifier's open-loop output resistance is considered, the capacitance introduces an additional pole in the signal path that can decrease the phase margin. When the primary considerations are frequency-response flatness, pulse response fidelity, or distortion, the simplest and most effective solution is to isolate the capacitive load

from the feedback loop by inserting a series isolation resistor between the amplifier output and the capacitive load. This does not eliminate the pole from the loop response, but rather shifts it and adds a zero at a higher frequency. The additional zero cancels the phase lag from the capacitive-load pole, thus increasing the phase margin and improving stability.

Power Supply Decoupling Techniques and Recommendations

Power-supply decoupling is a critical aspect of any high-performance amplifier design process. Careful decoupling provides higher-quality ac performance, most notably improved distortion performance. The following guidelines ensure the highest level of performance.

1. Place decoupling capacitors as close to the power-supply inputs as possible, with the goal of minimizing the inductance of the path from ground to the power supply
2. Placement priority; locate the smallest-value capacitors nearest to the device.
3. Solid power and ground planes are recommended to reduce the inductance along power-supply return-current paths, with the exception of the areas underneath the input and output pins.
4. Recommended values for power supply decoupling include a bulk decoupling capacitor (6.8 to 22 μF), a mid-range decoupling capacitor (0.1 μF) and a high frequency decoupling capacitor (1000 pF) for each supply. A 100 pF capacitor can be used across the supplies as well for extremely high-frequency return currents, but often is not required.

BOARD LAYOUT

Achieving optimum performance with a high-frequency amplifier like the SN1050x requires careful attention to board layout parasitics and external component types.

Recommendations to optimize performance include:

1. **Minimize parasitic capacitance to any ac ground for all signal I/O pins.** Parasitic capacitance on the output and inverting-input pins can cause instability: on the noninverting input, it can react with the source impedance to cause unintentional band limiting. To reduce unwanted capacitance, open a window in all ground and power planes around the signal I/O pins. Keep ground and power planes unbroken elsewhere on the board.
2. **Minimize the distance ($< 0.25''$) from the power-supply pins to high frequency 0.1- μF decoupling capacitors.** At the device pins, the

ground- and power-plane layout should not be in close proximity to the signal I/O pins. Avoid narrow power and ground traces to minimize inductance between the pins and the decoupling capacitors. The power supply connections should always be decoupled with these capacitors. Larger (2.2- μF to 6.8- μF) decoupling capacitors, effective at lower frequency, should also be used on the main supply pins. These may be placed somewhat farther from the device and may be shared among several devices in the same area of the PC board.

3. **Careful selection and placement of external components preserves the high frequency performance of the SN1050x.** Choose low-reactance resistors. Surface-mount resistors work best, and allow a tighter overall layout. Metal-film and carbon-composition axial-lead resistors can also provide good high-frequency performance. Again, keep component leads and PC-board trace length as short as possible. Never use wirewound resistors in a high frequency application. Since the output pin and inverting-input pin are the most sensitive to parasitic capacitance, always position the feedback and series-output resistor, if any, as close as possible to the output pin. Other network components, such as noninverting-input termination resistors, should also be placed close to the package. Where double-sided component mounting is allowed, place the feedback resistor directly under the package on the other side of the board between the output and inverting input pins. Even with a low parasitic capacitance shunting the external resistors, excessively high resistor values can create significant time constants that can degrade performance. Good axial-lead metal-film or surface-mount resistors have approximately 0.2 pF in shunt with the resistor. For resistor values $> 2.0 \text{ k}\Omega$, this parasitic capacitance can add a pole and/or a zero below 400 MHz that can affect circuit operation. Keep resistor values as low as possible, consistent with load-driving considerations. A good starting point for design is to set the R_f to 1.3 k Ω for low-gain, noninverting applications. This automatically keeps the resistor noise terms low, and minimizes the effect of their parasitic capacitance.
4. **Connections to other wideband devices on the board may be made with short, direct traces or through onboard transmission lines.** For short connections, consider the trace and the input to the next device as a lumped capacitive load. Use relatively wide traces (50 mils to 100 mils), preferably with ground and power planes opened up around them. Low parasitic capacitive loads ($< 4 \text{ pF}$) may not need an $R_{(ISO)}$, since the SN1050x is nominally compensated to operate

with a 2-pF parasitic load. Higher parasitic capacitive loads without an $R_{(ISO)}$ are allowed as the signal gain increases (increasing the unloaded phase margin). If a long trace is required, and the 6-dB signal loss intrinsic to a doubly-terminated transmission line is acceptable, implement a matched-impedance transmission line using microstrip or stripline techniques (consult an ECL design handbook for microstrip and stripline layout techniques). A 50- Ω environment is normally not necessary onboard, and in fact a higher-impedance environment improves distortion as shown in the distortion-versus-load plots. With a characteristic board-trace impedance definition based on board material and trace dimensions, a matching series resistor in the trace from the output of the SN1050x is used as well as a terminating shunt resistor at the input of the destination device. Remember also that the terminating impedance is the parallel combination of the shunt resistor and the input impedance of the destination device: this total effective impedance should be set to match the trace impedance. If the 6-dB attenuation of a doubly terminated transmission line is unacceptable, a long trace can be series-terminated at the source end only. Treat the trace as a capacitive load in this case and add an $R_{(ISO)}$ resistor in series with the output to isolate any capacitance to the amplifier. This setting does not preserve the signal integrity of a doubly-terminated line. If the input impedance of the destination device is low, the signal is attenuated due to the voltage divider formed by the series output into the terminating impedance.

5. **Socketing a high speed part like the SN1050x is not recommended.** The additional lead length and pin-to-pin capacitance introduced by the socket can create a troublesome parasitic network which can make it almost impossible to achieve a smooth, stable frequency response. Best results are obtained by soldering the SN1050x onto the board.

THERMAL ANALYSIS

The SN1050x family of devices does not incorporate automatic thermal shutoff protection, so the designer must take care to ensure that the design does not violate the absolute-maximum junction temperature of the device. Failure may result if the absolute-maximum junction temperature of 150°C is exceeded.

The thermal characteristics of the device are dictated by the package and the PC board. Maximum power dissipation for a given package can be calculated using the following formula.

$$P_{Dmax} = \frac{T_{max} - T_A}{\theta_{JA}}$$

where:

P_{Dmax} is the maximum power dissipation in the amplifier (W).

T_{max} is the absolute maximum junction temperature (°C).

T_A is the ambient temperature (°C).

$\theta_{JA} = \theta_{JC} + \theta_{CA}$

θ_{JC} is the thermal coefficient from the silicon junctions to the case (°C/W).

θ_{CA} is the thermal coefficient from the case to ambient air (°C/W).

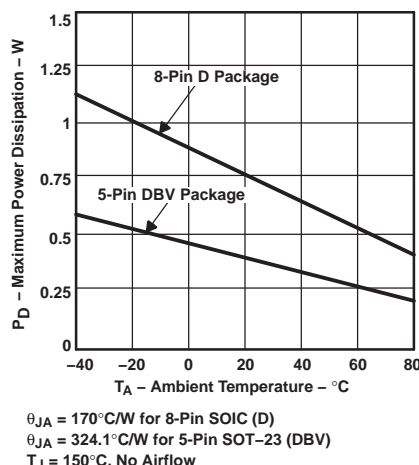

Figure 46. Maximum Power Dissipation vs Ambient Temperature

When determining whether or not the device satisfies the maximum power dissipation requirement, it is important to consider not only quiescent power dissipation, but also dynamic power dissipation. Often maximum power dissipation is difficult to quantify because the signal pattern is inconsistent, but an estimate of the RMS power dissipation can provide visibility into a possible problem.

PACKAGING INFORMATION

| Orderable Device | Status (1) | Package Type | Package Drawing | Pins | Package Qty | Eco Plan (2) | Lead finish/ Ball material (6) | MSL Peak Temp (3) | Op Temp (°C) | Device Marking (4/5) | Samples |
|------------------|---------------|--------------|-----------------|------|-------------|-----------------|--------------------------------------|----------------------|--------------|-------------------------|-------------------------|
| SN10501D | ACTIVE | SOIC | D | 8 | 75 | RoHS & Green | NIPDAU | Level-1-260C-UNLIM | -40 to 85 | 10501D | Samples |
| SN10501DBVR | ACTIVE | SOT-23 | DBV | 5 | 3000 | RoHS & Green | NIPDAU | Level-1-260C-UNLIM | -40 to 85 | SBBI | Samples |
| SN10501DBVT | ACTIVE | SOT-23 | DBV | 5 | 250 | RoHS & Green | NIPDAU | Level-1-260C-UNLIM | -40 to 85 | SBBI | Samples |
| SN10501DBVTG4 | ACTIVE | SOT-23 | DBV | 5 | 250 | RoHS & Green | NIPDAU | Level-1-260C-UNLIM | -40 to 85 | SBBI | Samples |
| SN10501DGK | ACTIVE | VSSOP | DGK | 8 | 80 | RoHS & Green | NIPDAU | Level-1-260C-UNLIM | -40 to 85 | BHA | Samples |
| SN10501DGKG4 | ACTIVE | VSSOP | DGK | 8 | 80 | RoHS & Green | NIPDAU | Level-1-260C-UNLIM | -40 to 85 | BHA | Samples |
| SN10501DGN | ACTIVE | HVSSOP | DGN | 8 | 80 | RoHS & Green | NIPDAU | Level-1-260C-UNLIM | -40 to 85 | AJU | Samples |
| SN10502D | ACTIVE | SOIC | D | 8 | 75 | RoHS & Green | NIPDAU | Level-1-260C-UNLIM | -40 to 85 | 10502D | Samples |
| SN10502DGK | ACTIVE | VSSOP | DGK | 8 | 80 | RoHS & Green | NIPDAU | Level-1-260C-UNLIM | -40 to 85 | AJT | Samples |
| SN10502DGKR | ACTIVE | VSSOP | DGK | 8 | 2500 | RoHS & Green | NIPDAU | Level-1-260C-UNLIM | -40 to 85 | AJT | Samples |
| SN10502DGN | ACTIVE | HVSSOP | DGN | 8 | 80 | RoHS & Green | NIPDAU | Level-1-260C-UNLIM | -40 to 85 | AJV | Samples |
| SN10502DR | ACTIVE | SOIC | D | 8 | 2500 | RoHS & Green | NIPDAU | Level-1-260C-UNLIM | -40 to 85 | 10502D | Samples |
| SN10503D | ACTIVE | SOIC | D | 14 | 50 | RoHS & Green | NIPDAU | Level-1-260C-UNLIM | -40 to 85 | 10503D | Samples |
| SN10503PWP | ACTIVE | HTSSOP | PWP | 14 | 90 | RoHS & Green | NIPDAU | Level-2-260C-1 YEAR | -40 to 85 | SN10503 | Samples |

(1) The marketing status values are defined as follows:

ACTIVE: Product device recommended for new designs.

LIFEBUY: TI has announced that the device will be discontinued, and a lifetime-buy period is in effect.

NRND: Not recommended for new designs. Device is in production to support existing customers, but TI does not recommend using this part in a new design.

PREVIEW: Device has been announced but is not in production. Samples may or may not be available.

OBSOLETE: TI has discontinued the production of the device.

(2) **RoHS:** TI defines "RoHS" to mean semiconductor products that are compliant with the current EU RoHS requirements for all 10 RoHS substances, including the requirement that RoHS substance do not exceed 0.1% by weight in homogeneous materials. Where designed to be soldered at high temperatures, "RoHS" products are suitable for use in specified lead-free processes. TI may reference these types of products as "Pb-Free".

RoHS Exempt: TI defines "RoHS Exempt" to mean products that contain lead but are compliant with EU RoHS pursuant to a specific EU RoHS exemption.

Green: TI defines "Green" to mean the content of Chlorine (Cl) and Bromine (Br) based flame retardants meet JS709B low halogen requirements of ≤ 1000 ppm threshold. Antimony trioxide based flame retardants must also meet the ≤ 1000 ppm threshold requirement.

(3) MSL, Peak Temp. - The Moisture Sensitivity Level rating according to the JEDEC industry standard classifications, and peak solder temperature.

(4) There may be additional marking, which relates to the logo, the lot trace code information, or the environmental category on the device.

(5) Multiple Device Markings will be inside parentheses. Only one Device Marking contained in parentheses and separated by a "~" will appear on a device. If a line is indented then it is a continuation of the previous line and the two combined represent the entire Device Marking for that device.

(6) Lead finish/Ball material - Orderable Devices may have multiple material finish options. Finish options are separated by a vertical ruled line. Lead finish/Ball material values may wrap to two lines if the finish value exceeds the maximum column width.

Important Information and Disclaimer: The information provided on this page represents TI's knowledge and belief as of the date that it is provided. TI bases its knowledge and belief on information provided by third parties, and makes no representation or warranty as to the accuracy of such information. Efforts are underway to better integrate information from third parties. TI has taken and continues to take reasonable steps to provide representative and accurate information but may not have conducted destructive testing or chemical analysis on incoming materials and chemicals. TI and TI suppliers consider certain information to be proprietary, and thus CAS numbers and other limited information may not be available for release.

In no event shall TI's liability arising out of such information exceed the total purchase price of the TI part(s) at issue in this document sold by TI to Customer on an annual basis.

TAPE AND REEL INFORMATION

QUADRANT ASSIGNMENTS FOR PIN 1 ORIENTATION IN TAPE

*All dimensions are nominal

| Device | Package Type | Package Drawing | Pins | SPQ | Reel Diameter (mm) | Reel Width W1 (mm) | A0 (mm) | B0 (mm) | K0 (mm) | P1 (mm) | W (mm) | Pin1 Quadrant |
|-------------|--------------|-----------------|------|------|--------------------|--------------------|---------|---------|---------|---------|--------|---------------|
| SN10501DBVR | SOT-23 | DBV | 5 | 3000 | 180.0 | 9.0 | 3.15 | 3.2 | 1.4 | 4.0 | 8.0 | Q3 |
| SN10501DBVT | SOT-23 | DBV | 5 | 250 | 180.0 | 9.0 | 3.15 | 3.2 | 1.4 | 4.0 | 8.0 | Q3 |
| SN10502DGKR | VSSOP | DGK | 8 | 2500 | 330.0 | 12.4 | 5.3 | 3.4 | 1.4 | 8.0 | 12.0 | Q1 |
| SN10502DR | SOIC | D | 8 | 2500 | 330.0 | 12.4 | 6.4 | 5.2 | 2.1 | 8.0 | 12.0 | Q1 |

TAPE AND REEL BOX DIMENSIONS

*All dimensions are nominal

| Device | Package Type | Package Drawing | Pins | SPQ | Length (mm) | Width (mm) | Height (mm) |
|-------------|--------------|-----------------|------|------|-------------|------------|-------------|
| SN10501DBVR | SOT-23 | DBV | 5 | 3000 | 182.0 | 182.0 | 20.0 |
| SN10501DBVT | SOT-23 | DBV | 5 | 250 | 182.0 | 182.0 | 20.0 |
| SN10502DGKR | VSSOP | DGK | 8 | 2500 | 358.0 | 335.0 | 35.0 |
| SN10502DR | SOIC | D | 8 | 2500 | 350.0 | 350.0 | 43.0 |

TUBE

*All dimensions are nominal

| Device | Package Name | Package Type | Pins | SPQ | L (mm) | W (mm) | T (μm) | B (mm) |
|------------|--------------|--------------|------|-----|--------|--------|--------|--------|
| SN10501D | D | SOIC | 8 | 75 | 505.46 | 6.76 | 3810 | 4 |
| SN10502D | D | SOIC | 8 | 75 | 505.46 | 6.76 | 3810 | 4 |
| SN10502D | D | SOIC | 8 | 75 | 505.46 | 6.76 | 3810 | 4 |
| SN10503D | D | SOIC | 14 | 50 | 505.46 | 6.76 | 3810 | 4 |
| SN10503PWP | PWP | HTSSOP | 14 | 90 | 530 | 10.2 | 3600 | 3.5 |

PWP (R-PDSO-G14)

PowerPAD™ PLASTIC SMALL OUTLINE

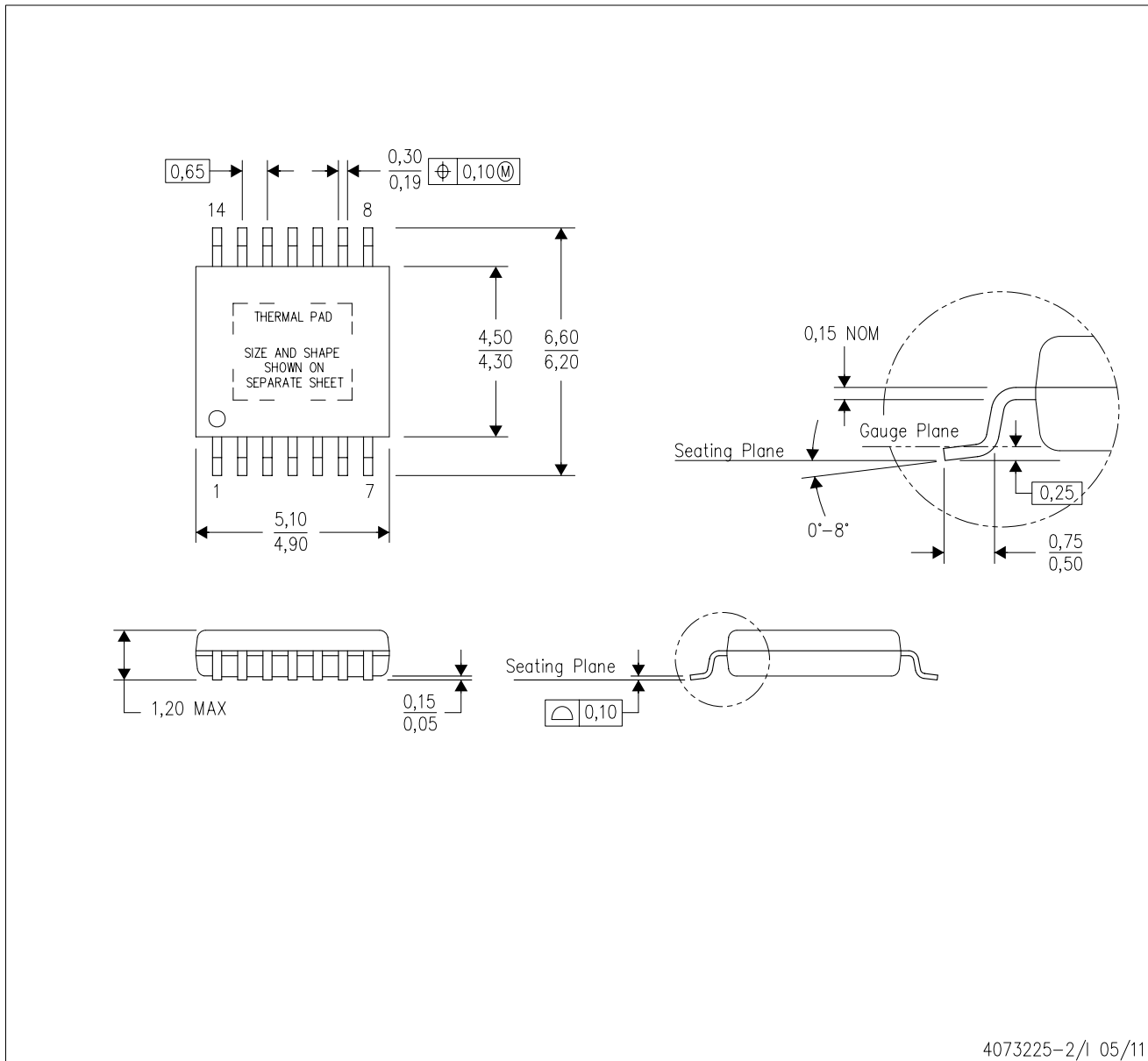

- NOTES:
- All linear dimensions are in millimeters.
 - This drawing is subject to change without notice.
 - Body dimensions do not include mold flash or protrusions. Mold flash and protrusion shall not exceed 0.15 per side.
 - This package is designed to be soldered to a thermal pad on the board. Refer to Technical Brief, PowerPad Thermally Enhanced Package, Texas Instruments Literature No. SLMA002 for information regarding recommended board layout. This document is available at www.ti.com <<http://www.ti.com>>.
 - See the additional figure in the Product Data Sheet for details regarding the exposed thermal pad features and dimensions.
 - Falls within JEDEC MO-153

PowerPAD is a trademark of Texas Instruments.

THERMAL PAD MECHANICAL DATA

PWP (R-PDSO-G14)

PowerPAD™ SMALL PLASTIC OUTLINE

THERMAL INFORMATION

This PowerPAD™ package incorporates an exposed thermal pad that is designed to be attached to a printed circuit board (PCB). The thermal pad must be soldered directly to the PCB. After soldering, the PCB can be used as a heatsink. In addition, through the use of thermal vias, the thermal pad can be attached directly to the appropriate copper plane shown in the electrical schematic for the device, or alternatively, can be attached to a special heatsink structure designed into the PCB. This design optimizes the heat transfer from the integrated circuit (IC).

For additional information on the PowerPAD package and how to take advantage of its heat dissipating abilities, refer to Technical Brief, PowerPAD Thermally Enhanced Package, Texas Instruments Literature No. SLMA002 and Application Brief, PowerPAD Made Easy, Texas Instruments Literature No. SLMA004. Both documents are available at www.ti.com.

The exposed thermal pad dimensions for this package are shown in the following illustration.

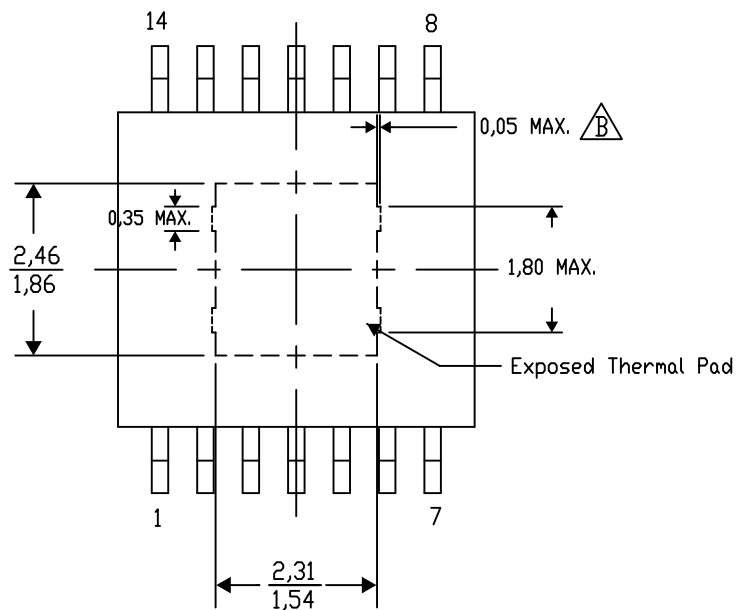

Top View

Exposed Thermal Pad Dimensions

4206332-44/AO 01/16

NOTE: A. All linear dimensions are in millimeters

 Exposed tie strap features may not be present.

PowerPAD is a trademark of Texas Instruments

PWP (R-PDSO-G14)

PowerPAD™ PLASTIC SMALL OUTLINE

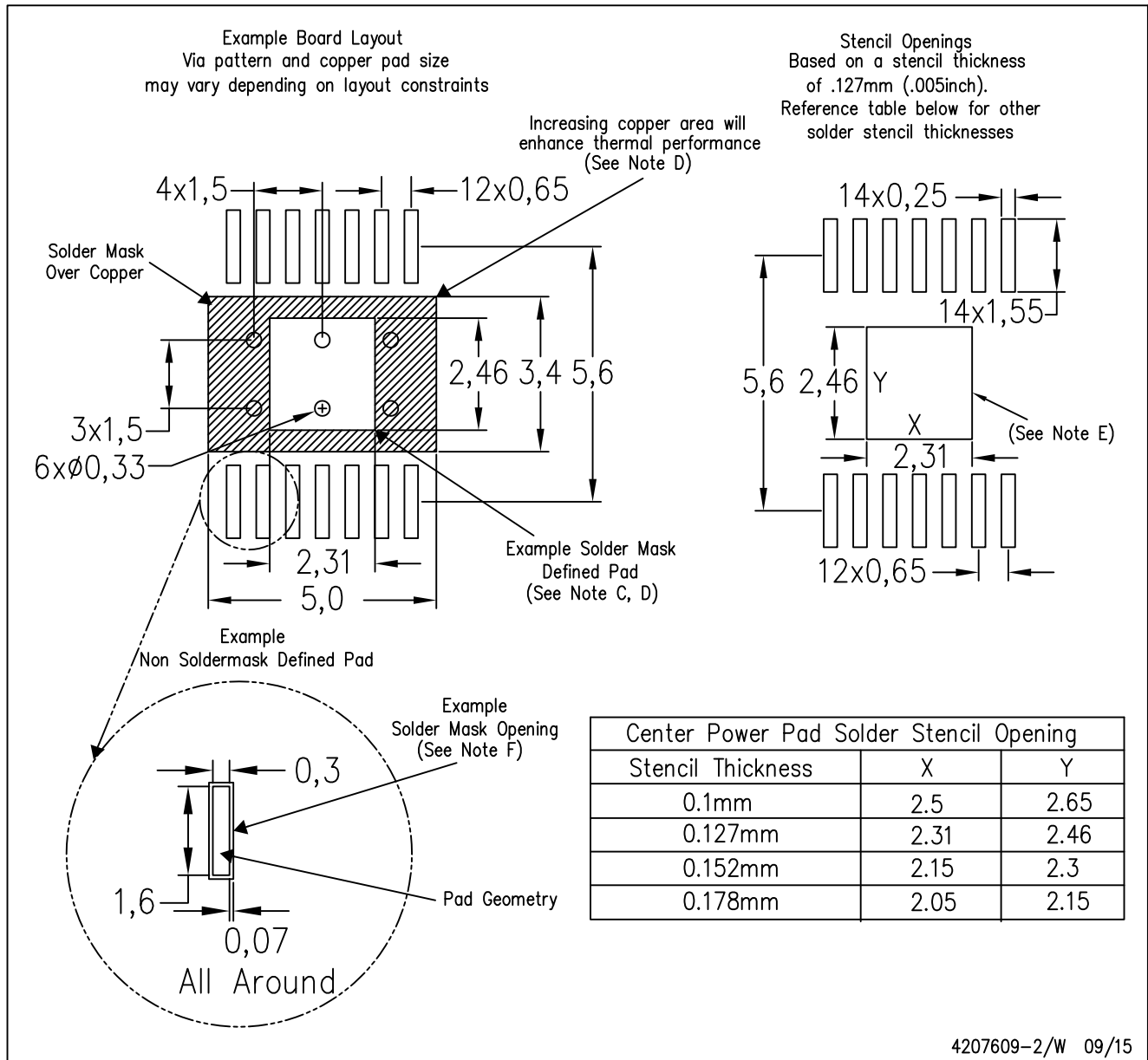

4207609-2/W 09/15

- NOTES:
- A. All linear dimensions are in millimeters.
 - B. This drawing is subject to change without notice.
 - C. Customers should place a note on the circuit board fabrication drawing not to alter the center solder mask defined pad.
 - D. This package is designed to be soldered to a thermal pad on the board. Refer to Technical Brief, PowerPAD Thermally Enhanced Package, Texas Instruments Literature No. SLMA002, SLMA004, and also the Product Data Sheets for specific thermal information, via requirements, and recommended board layout. These documents are available at www.ti.com <<http://www.ti.com>>. Publication IPC-7351 is recommended for alternate designs.
 - E. Laser cutting apertures with trapezoidal walls and also rounding corners will offer better paste release. Customers should contact their board assembly site for stencil design recommendations. Example stencil design based on a 50% volumetric metal load solder paste. Refer to IPC-7525 for other stencil recommendations.
 - F. Customers should contact their board fabrication site for solder mask tolerances between and around signal pads.

EXAMPLE BOARD LAYOUT

DBV0005A

SOT-23 - 1.45 mm max height

SMALL OUTLINE TRANSISTOR

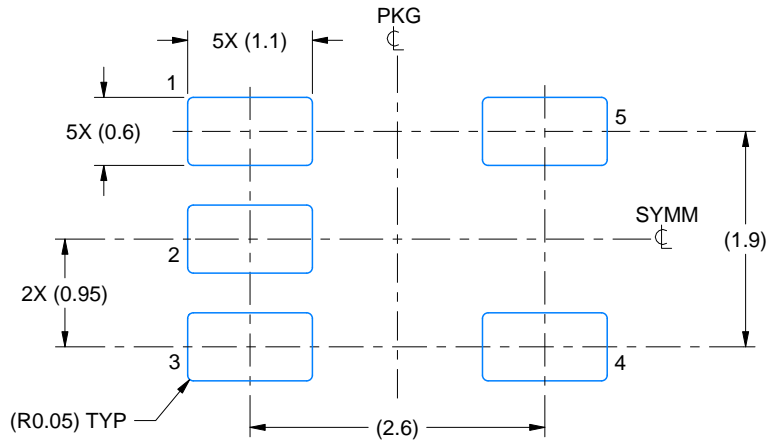

LAND PATTERN EXAMPLE
EXPOSED METAL SHOWN
SCALE:15X

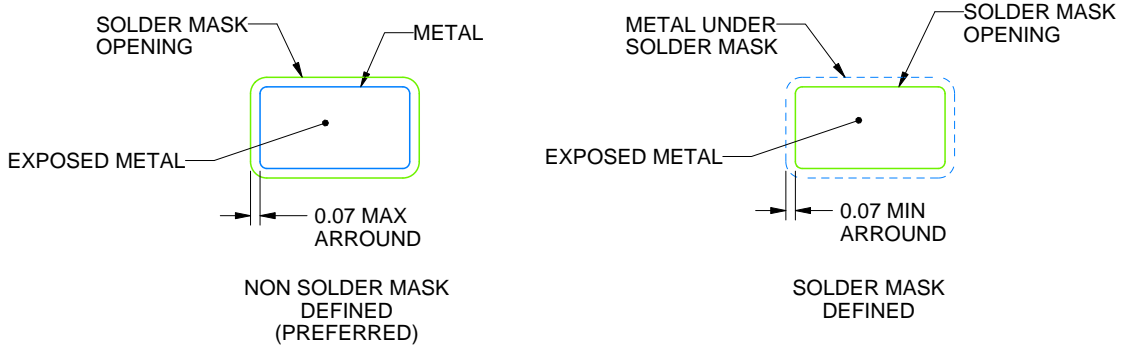

SOLDER MASK DETAILS

4214839/F 06/2021

NOTES: (continued)

- 5. Publication IPC-7351 may have alternate designs.
- 6. Solder mask tolerances between and around signal pads can vary based on board fabrication site.

EXAMPLE STENCIL DESIGN

DBV0005A

SOT-23 - 1.45 mm max height

SMALL OUTLINE TRANSISTOR

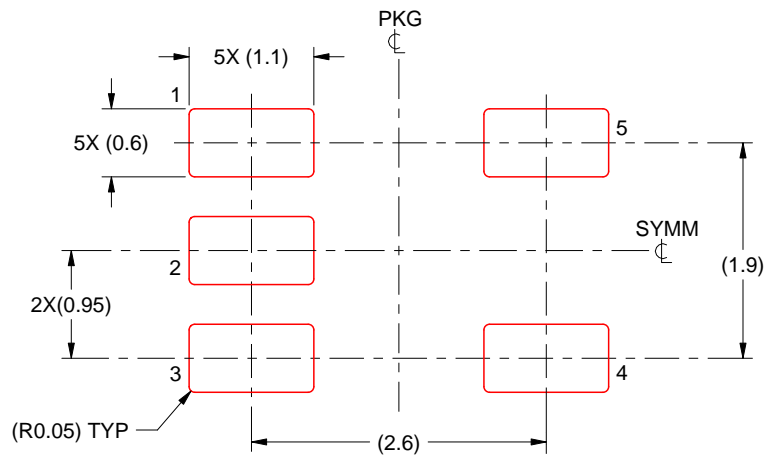

SOLDER PASTE EXAMPLE
BASED ON 0.125 mm THICK STENCIL
SCALE:15X

4214839/F 06/2021

NOTES: (continued)

7. Laser cutting apertures with trapezoidal walls and rounded corners may offer better paste release. IPC-7525 may have alternate design recommendations.
8. Board assembly site may have different recommendations for stencil design.

GENERIC PACKAGE VIEW

DGN 8

PowerPAD VSSOP - 1.1 mm max height

3 x 3, 0.65 mm pitch

SMALL OUTLINE PACKAGE

This image is a representation of the package family, actual package may vary.
Refer to the product data sheet for package details.

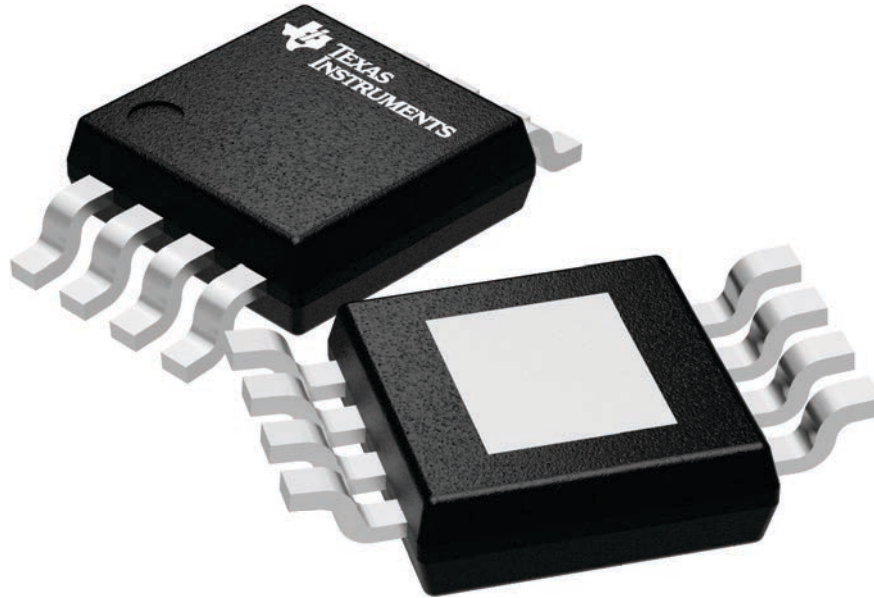

4225482/A

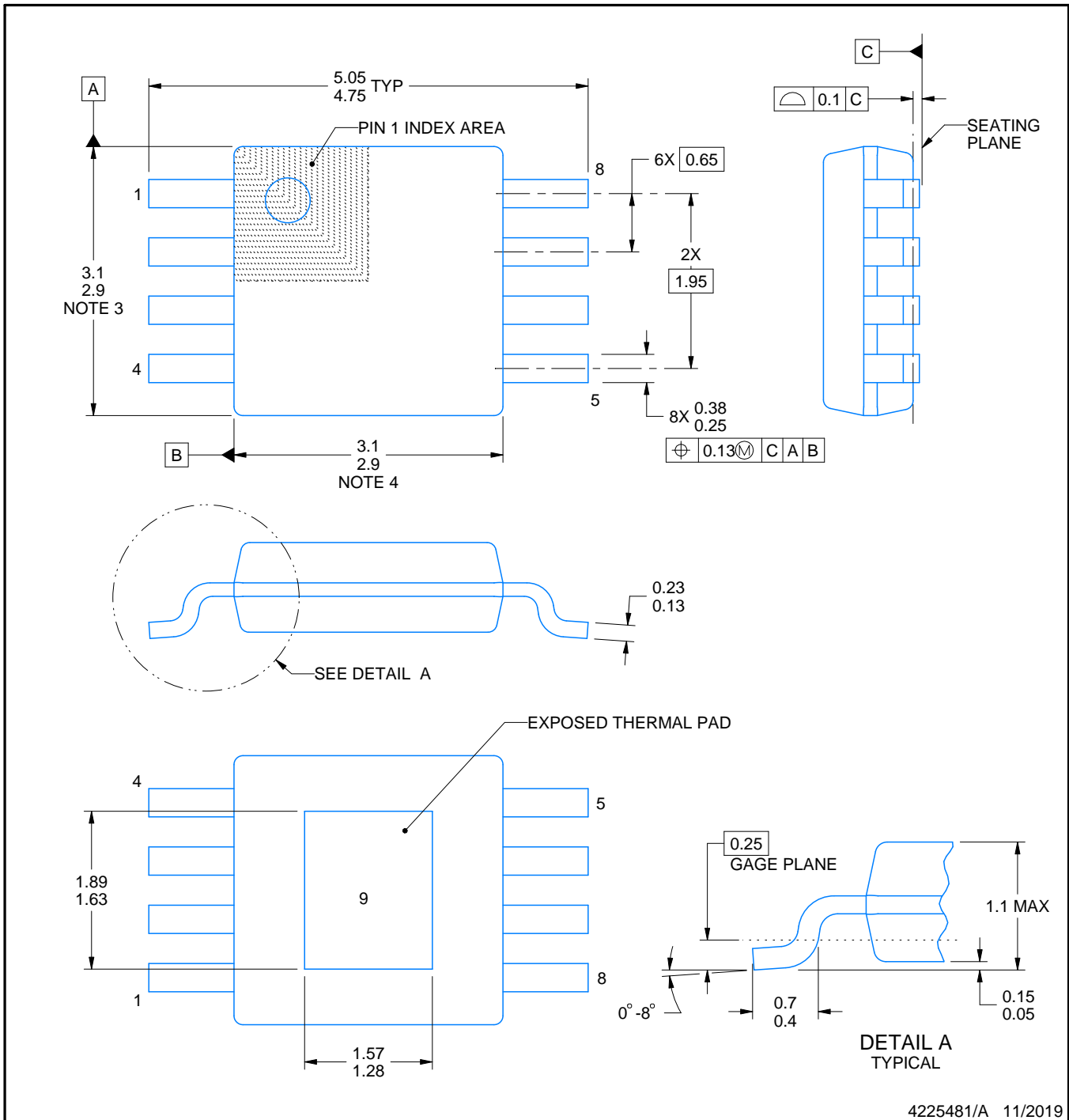
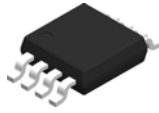

4225481/A 11/2019

NOTES:

PowerPAD is a trademark of Texas Instruments.

1. All linear dimensions are in millimeters. Any dimensions in parenthesis are for reference only. Dimensioning and tolerancing per ASME Y14.5M.
2. This drawing is subject to change without notice.
3. This dimension does not include mold flash, protrusions, or gate burrs. Mold flash, protrusions, or gate burrs shall not exceed 0.15 mm per side.
4. This dimension does not include interlead flash. Interlead flash shall not exceed 0.25 mm per side.
5. Reference JEDEC registration MO-187.

EXAMPLE BOARD LAYOUT

DGN0008D

PowerPAD™ VSSOP - 1.1 mm max height

SMALL OUTLINE PACKAGE

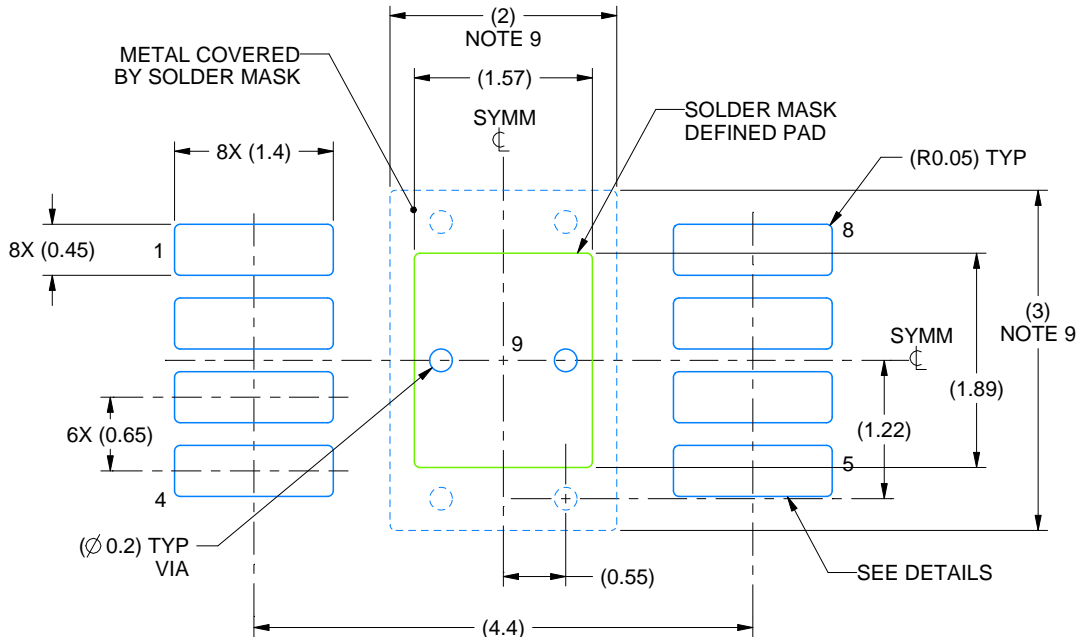

LAND PATTERN EXAMPLE
EXPOSED METAL SHOWN
SCALE: 15X

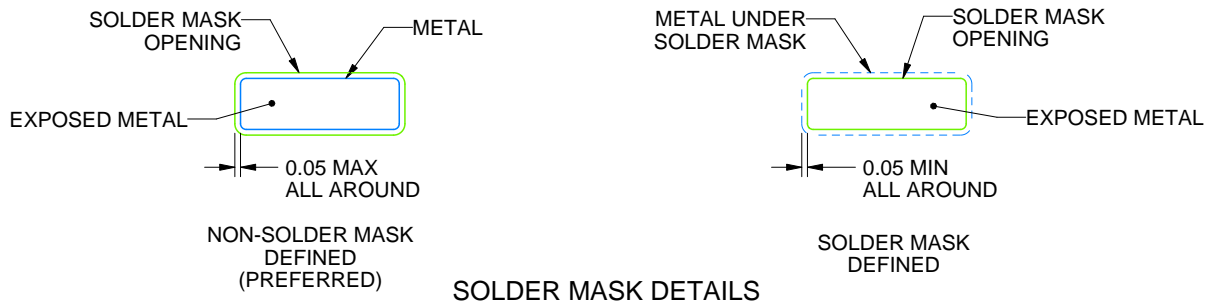

SOLDER MASK DETAILS

4225481/A 11/2019

NOTES: (continued)

6. Publication IPC-7351 may have alternate designs.
7. Solder mask tolerances between and around signal pads can vary based on board fabrication site.
8. Vias are optional depending on application, refer to device data sheet. If any vias are implemented, refer to their locations shown on this view. It is recommended that vias under paste be filled, plugged or tented.
9. Size of metal pad may vary due to creepage requirement.

EXAMPLE STENCIL DESIGN

DGN0008D

PowerPAD™ VSSOP - 1.1 mm max height

SMALL OUTLINE PACKAGE

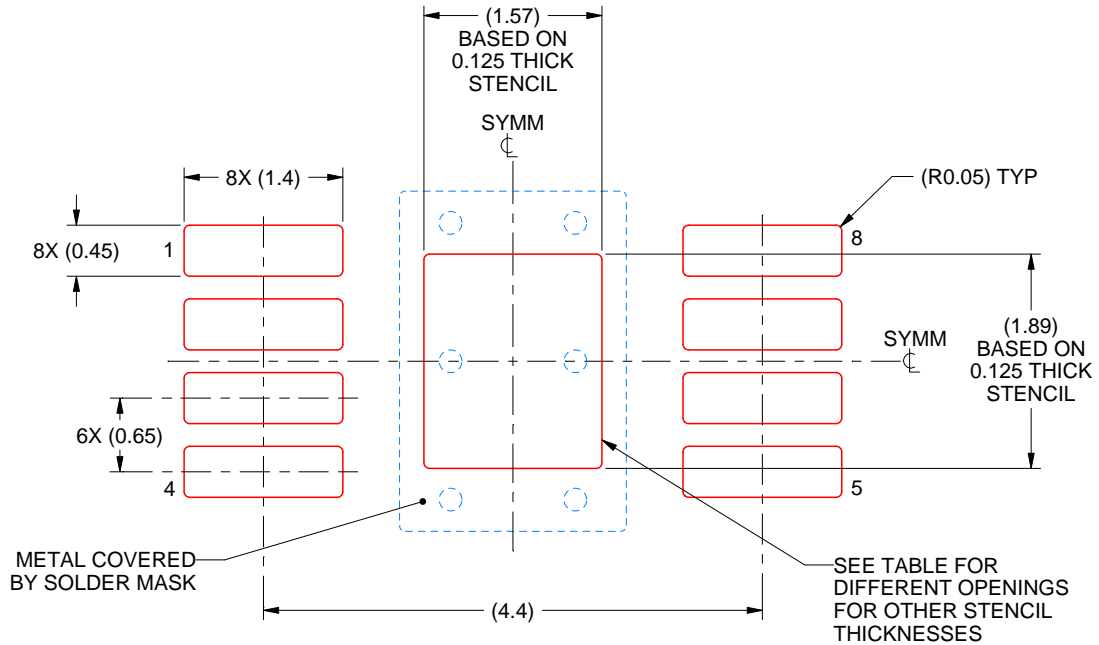

SOLDER PASTE EXAMPLE
 EXPOSED PAD 9:
 100% PRINTED SOLDER COVERAGE BY AREA
 SCALE: 15X

| STENCIL THICKNESS | SOLDER STENCIL OPENING |
|-------------------|------------------------|
| 0.1 | 1.76 X 2.11 |
| 0.125 | 1.57 X 1.89 (SHOWN) |
| 0.15 | 1.43 X 1.73 |
| 0.175 | 1.33 X 1.60 |

4225481/A 11/2019

NOTES: (continued)

10. Laser cutting apertures with trapezoidal walls and rounded corners may offer better paste release. IPC-7525 may have alternate design recommendations.
11. Board assembly site may have different recommendations for stencil design.

D (R-PDSO-G14)

PLASTIC SMALL OUTLINE

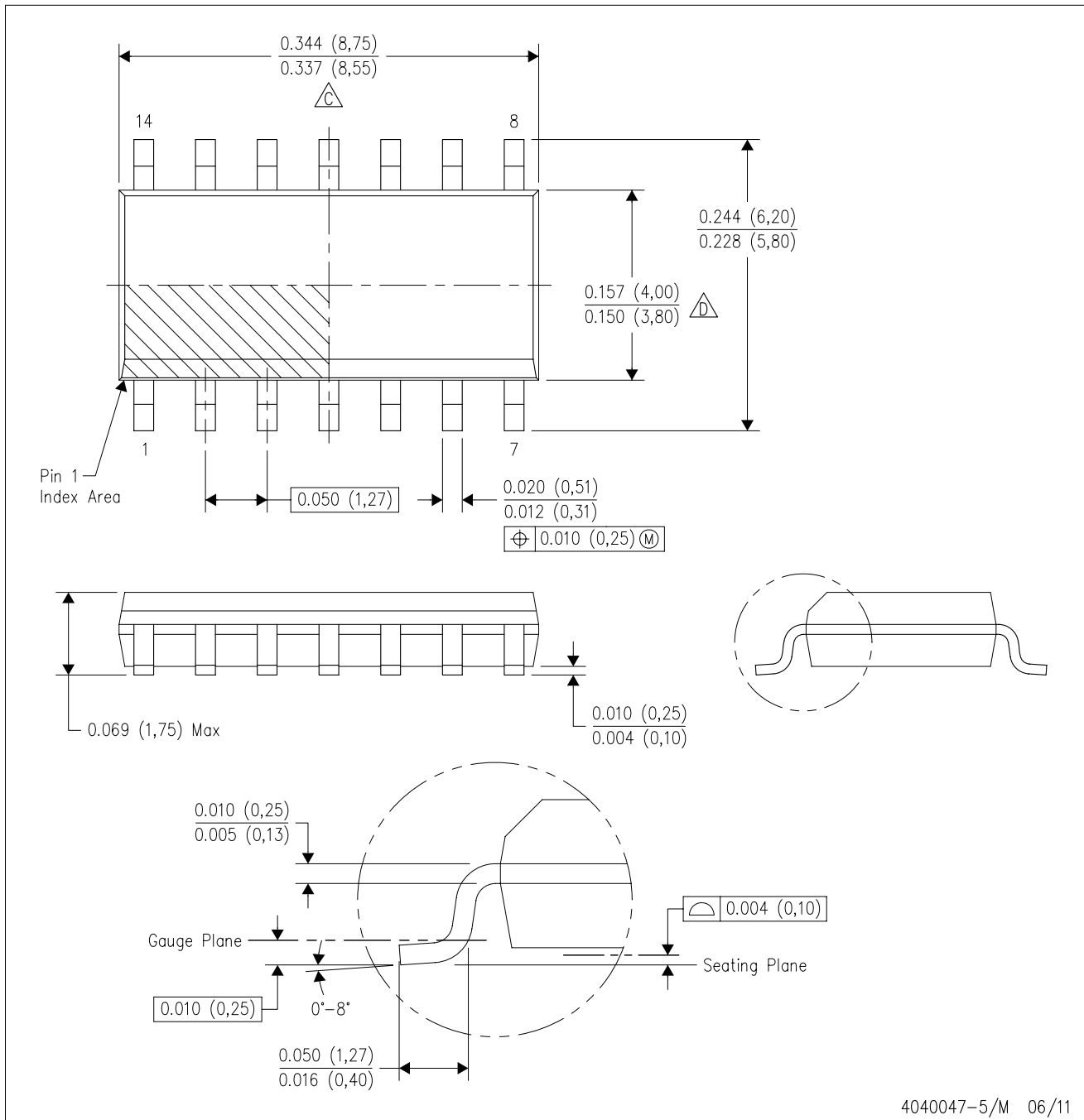

- NOTES:
- A. All linear dimensions are in inches (millimeters).
 - B. This drawing is subject to change without notice.
 - △C Body length does not include mold flash, protrusions, or gate burrs. Mold flash, protrusions, or gate burrs shall not exceed 0.006 (0,15) each side.
 - △D Body width does not include interlead flash. Interlead flash shall not exceed 0.017 (0,43) each side.
 - E. Reference JEDEC MS-012 variation AB.

D (R-PDSO-G14)

PLASTIC SMALL OUTLINE

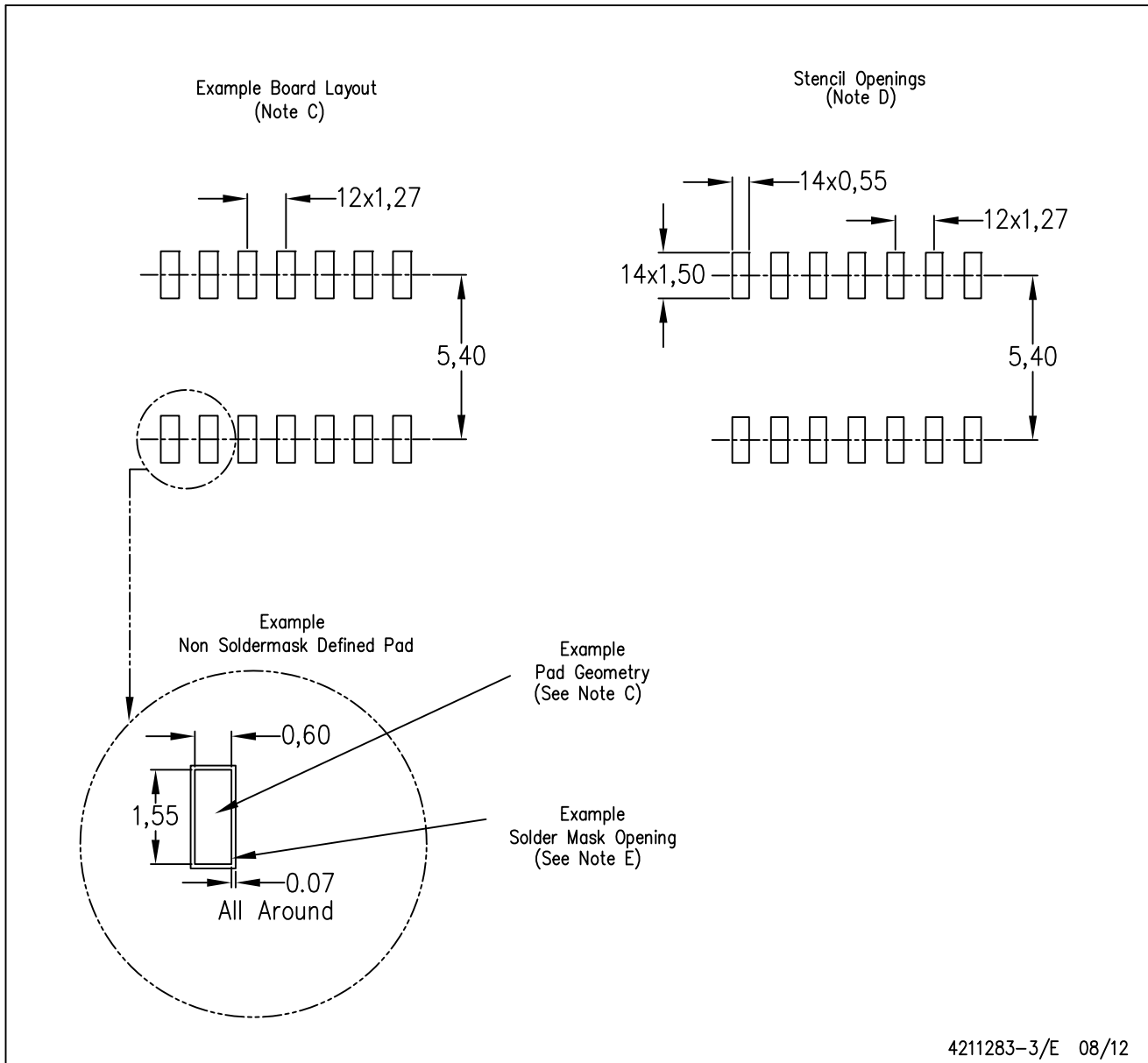

4211283-3/E 08/12

- NOTES:
- All linear dimensions are in millimeters.
 - This drawing is subject to change without notice.
 - Publication IPC-7351 is recommended for alternate designs.
 - Laser cutting apertures with trapezoidal walls and also rounding corners will offer better paste release. Customers should contact their board assembly site for stencil design recommendations. Refer to IPC-7525 for other stencil recommendations.
 - Customers should contact their board fabrication site for solder mask tolerances between and around signal pads.



D0008A

PACKAGE OUTLINE

SOIC - 1.75 mm max height

SMALL OUTLINE INTEGRATED CIRCUIT



4214825/C 02/2019

NOTES:

- Linear dimensions are in inches [millimeters]. Dimensions in parenthesis are for reference only. Controlling dimensions are in inches. Dimensioning and tolerancing per ASME Y14.5M.
- This drawing is subject to change without notice.
- This dimension does not include mold flash, protrusions, or gate burrs. Mold flash, protrusions, or gate burrs shall not exceed $.006$ [0.15] per side.
- This dimension does not include interlead flash.
- Reference JEDEC registration MS-012, variation AA.

EXAMPLE BOARD LAYOUT

D0008A

SOIC - 1.75 mm max height

SMALL OUTLINE INTEGRATED CIRCUIT



LAND PATTERN EXAMPLE
EXPOSED METAL SHOWN
SCALE:8X



SOLDER MASK DETAILS

4214825/C 02/2019

NOTES: (continued)

6. Publication IPC-7351 may have alternate designs.

7. Solder mask tolerances between and around signal pads can vary based on board fabrication site.

EXAMPLE STENCIL DESIGN

D0008A

SOIC - 1.75 mm max height

SMALL OUTLINE INTEGRATED CIRCUIT



SOLDER PASTE EXAMPLE
BASED ON .005 INCH [0.125 MM] THICK STENCIL
SCALE:8X

4214825/C 02/2019

NOTES: (continued)

8. Laser cutting apertures with trapezoidal walls and rounded corners may offer better paste release. IPC-7525 may have alternate design recommendations.
9. Board assembly site may have different recommendations for stencil design.

DGK (S-PDSO-G8)

PLASTIC SMALL-OUTLINE PACKAGE

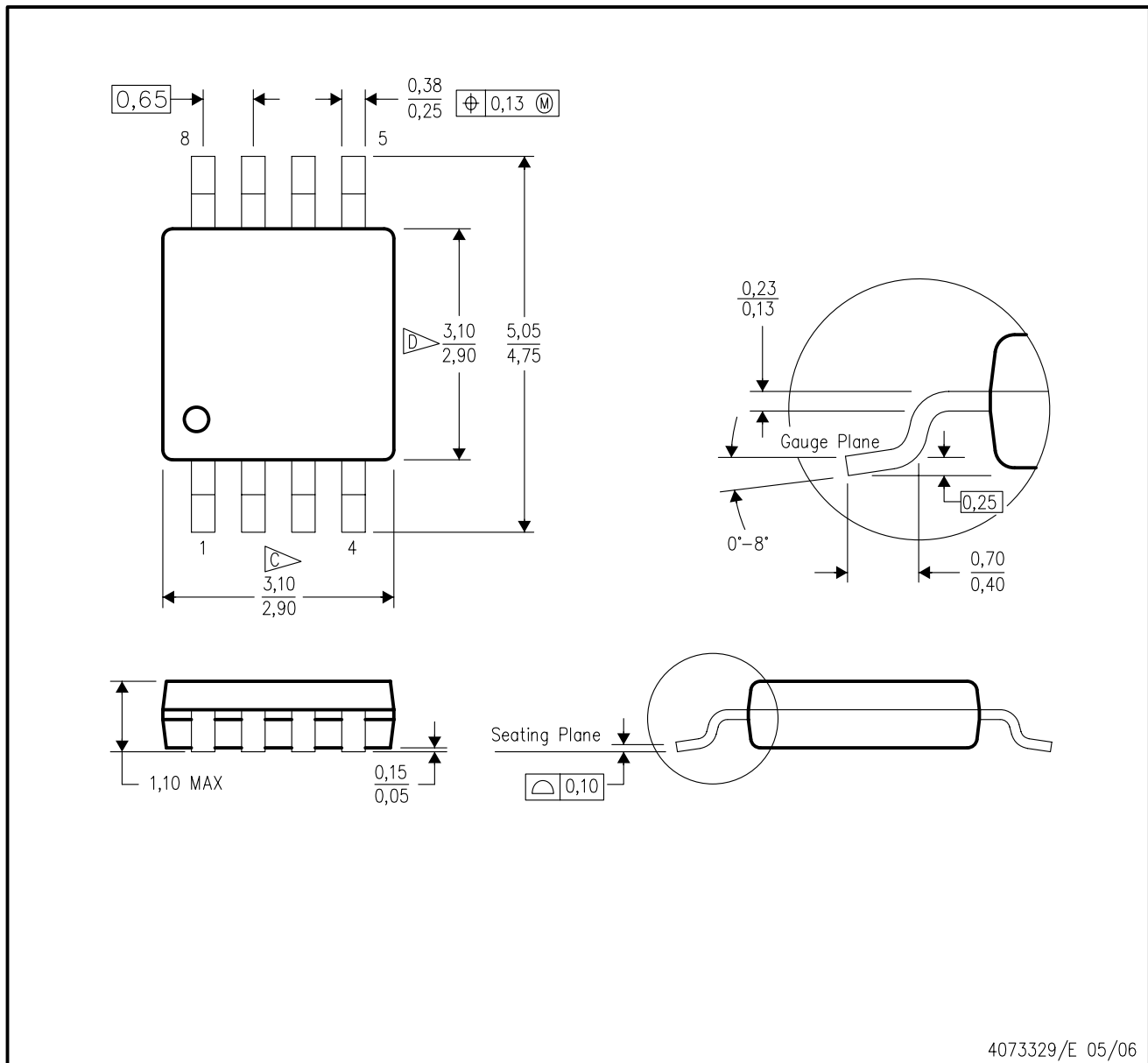

- NOTES:
- A. All linear dimensions are in millimeters.
 - B. This drawing is subject to change without notice.
 - C. Body length does not include mold flash, protrusions, or gate burrs. Mold flash, protrusions, or gate burrs shall not exceed 0.15 per end.
 - D. Body width does not include interlead flash. Interlead flash shall not exceed 0.50 per side.
 - E. Falls within JEDEC MO-187 variation AA, except interlead flash.



- NOTES:
- A. All linear dimensions are in millimeters.
 - B. This drawing is subject to change without notice.
 - C. Publication IPC-7351 is recommended for alternate designs.
 - D. Laser cutting apertures with trapezoidal walls and also rounding corners will offer better paste release. Customers should contact their board assembly site for stencil design recommendations. Refer to IPC-7525 for other stencil recommendations.
 - E. Customers should contact their board fabrication site for solder mask tolerances between and around signal pads.

IMPORTANT NOTICE AND DISCLAIMER

TI PROVIDES TECHNICAL AND RELIABILITY DATA (INCLUDING DATA SHEETS), DESIGN RESOURCES (INCLUDING REFERENCE DESIGNS), APPLICATION OR OTHER DESIGN ADVICE, WEB TOOLS, SAFETY INFORMATION, AND OTHER RESOURCES "AS IS" AND WITH ALL FAULTS, AND DISCLAIMS ALL WARRANTIES, EXPRESS AND IMPLIED, INCLUDING WITHOUT LIMITATION ANY IMPLIED WARRANTIES OF MERCHANTABILITY, FITNESS FOR A PARTICULAR PURPOSE OR NON-INFRINGEMENT OF THIRD PARTY INTELLECTUAL PROPERTY RIGHTS.

These resources are intended for skilled developers designing with TI products. You are solely responsible for (1) selecting the appropriate TI products for your application, (2) designing, validating and testing your application, and (3) ensuring your application meets applicable standards, and any other safety, security, regulatory or other requirements.

These resources are subject to change without notice. TI grants you permission to use these resources only for development of an application that uses the TI products described in the resource. Other reproduction and display of these resources is prohibited. No license is granted to any other TI intellectual property right or to any third party intellectual property right. TI disclaims responsibility for, and you will fully indemnify TI and its representatives against, any claims, damages, costs, losses, and liabilities arising out of your use of these resources.

TI's products are provided subject to [TI's Terms of Sale](#) or other applicable terms available either on ti.com or provided in conjunction with such TI products. TI's provision of these resources does not expand or otherwise alter TI's applicable warranties or warranty disclaimers for TI products.

TI objects to and rejects any additional or different terms you may have proposed.

Mailing Address: Texas Instruments, Post Office Box 655303, Dallas, Texas 75265
Copyright © 2022, Texas Instruments Incorporated