

# TLC5510, TLC5510A 8-BIT HIGH-SPEED ANALOG-TO-DIGITAL CONVERTERS

SLAS095L – SEPTEMBER 1994 – REVISED JUNE 2003

## features

- **Analog Input Range**
  - TLC5510 . . . 2 V Full Scale
  - TLC5510A . . . 4 V Full Scale
- **8-Bit Resolution**
- **Integral Linearity Error**
  - ±0.75 LSB Max (25°C)
  - ±1 LSB Max (–20°C to 75°C)
- **Differential Linearity Error**
  - ±0.5 LSB Max (25°C)
  - ±0.75 LSB Max (–20°C to 75°C)
- **Maximum Conversion Rate**  
20 Mega-Samples per Second (MSPS) Max

- **5-V Single-Supply Operation**
- **Low Power Consumption**  
TLC5510 . . . 127.5 mW Typ  
TLC5510A . . . 150 mW Typ  
(includes reference resistor dissipation)
- **TLC5510 is Interchangeable With Sony CXD1175**

## applications

- Digital TV
- Medical Imaging
- Video Conferencing
- High-Speed Data Conversion
- QAM Demodulators

## description

The TLC5510 and TLC5510A are CMOS, 8-bit, 20 MSPS analog-to-digital converters (ADCs) that utilize a semiflash architecture. The TLC5510 and TLC5510A operate with a single 5-V supply and typically consume only 130 mW of power. Included is an internal sample-and-hold circuit, parallel outputs with high-impedance mode, and internal reference resistors.

The semiflash architecture reduces power consumption and die size compared to flash converters. By implementing the conversion in a 2-step process, the number of comparators is significantly reduced. The latency of the data output valid is 2.5 clocks.

The TLC5510 uses the three internal reference resistors to create a standard, 2-V, full-scale conversion range using  $V_{DDA}$ . Only external jumpers are required to implement this option and eliminates the need for external reference resistors. The TLC5510A uses only the center internal resistor section with an externally applied 4-V reference such that a 4-V input signal can be used. Differential linearity is 0.5 LSB at 25°C and a maximum of 0.75 LSB over the full operating temperature range. Typical dynamic specifications include a differential gain of 1% and differential phase of 0.7 degrees.

The TLC5510 and TLC5510A are characterized for operation from –20°C to 75°C.

PW OR NS PACKAGE†  
(TOP VIEW)

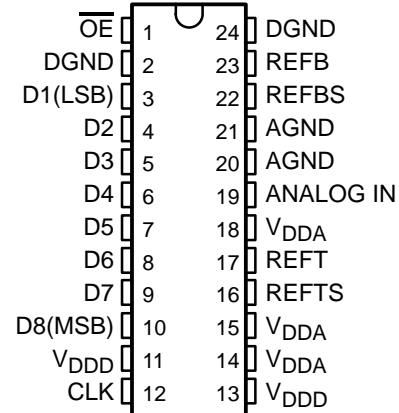

† Available in tape and reel only and ordered as the shown in the Available Options table below.

## AVAILABLE OPTIONS

TA	PACKAGE		MAXIMUM FULL-SCALE INPUT VOLTAGE
	TSSOP (PW)	SOP (NS) (TAPE AND REEL ONLY)	
–20°C to 75°C	TLC5510IPW	TLC5510INSLE	2 V
	–	TLC5510AINSLE	4 V



Please be aware that an important notice concerning availability, standard warranty, and use in critical applications of Texas Instruments semiconductor products and disclaimers thereto appears at the end of this data sheet.

PRODUCTION DATA information is current as of publication date. Products conform to specifications per the terms of Texas Instruments standard warranty. Production processing does not necessarily include testing of all parameters.

 **TEXAS  
INSTRUMENTS**

POST OFFICE BOX 655303 • DALLAS, TEXAS 75265

Copyright © 1994 – 2003, Texas Instruments Incorporated

# TLC5510, TLC5510A 8-BIT HIGH-SPEED ANALOG-TO-DIGITAL CONVERTERS

SLAS095L – SEPTEMBER 1994 – REVISED JUNE 2003

## functional block diagram

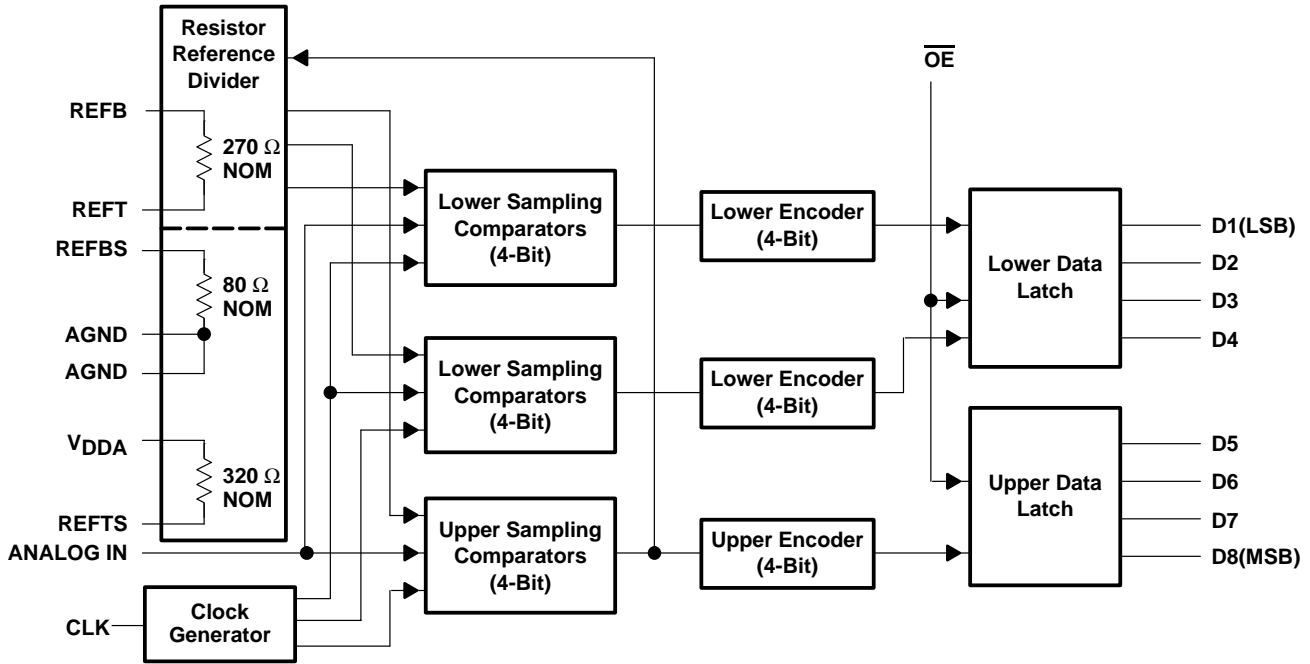

## schematics of inputs and outputs

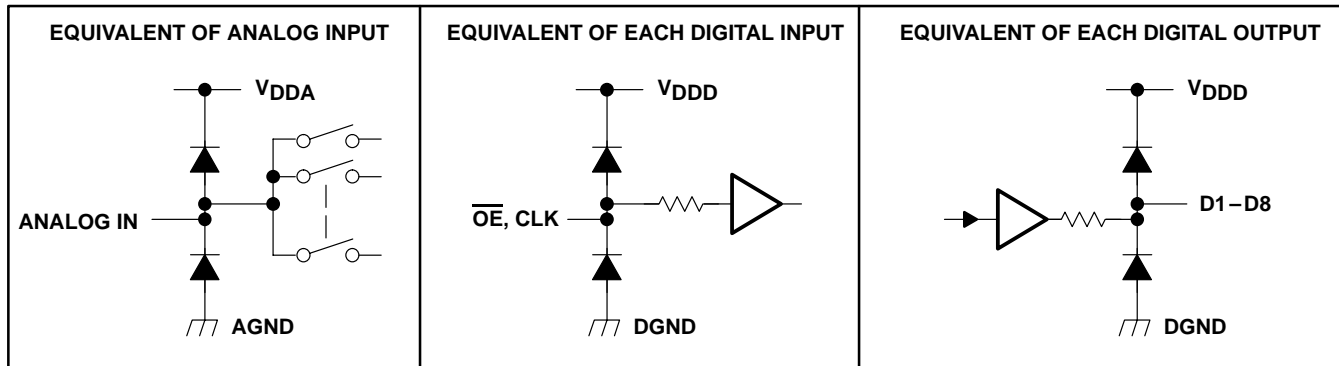

# TLC5510, TLC5510A

## 8-BIT HIGH-SPEED ANALOG-TO-DIGITAL CONVERTERS

SLAS095L – SEPTEMBER 1994 – REVISED JUNE 2003

### Terminal Functions

TERMINAL NAME	NO.	I/O	DESCRIPTION
AGND	20, 21		Analog ground
ANALOG IN	19	I	Analog input
CLK	12	I	Clock input
DGND	2, 24		Digital ground
D1–D8	3–10	O	Digital data out. D1 = LSB, D8 = MSB
$\overline{OE}$	1	I	Output enable. When $\overline{OE}$ = low, data is enabled. When $\overline{OE}$ = high, D1–D8 is in high-impedance state.
$V_{DDA}$	14, 15, 18		Analog supply voltage
$V_{DDD}$	11, 13		Digital supply voltage
REFB	23	I	Reference voltage in bottom
REFBS	22		Reference voltage in bottom. When using the TLC5510 internal voltage divider to generate a nominal 2-V reference, REFBS is shorted to REFB (see Figure 3). When using the TLC5510A, REFBS is connected to ground.
REFT	17	I	Reference voltage in top
REFTS	16		Reference voltage in top. When using the TLC5510 internal voltage divider to generate a nominal 2-V reference, REFTS is shorted to REFT (see Figure 3). When using the TLC5510A, REFTS is connected to $V_{DDA}$ .

### absolute maximum ratings†

Supply voltage, $V_{DDA}$ , $V_{DDD}$	7 V
Reference voltage input range, $V_{REFT}$ , $V_{REFB}$	AGND to $V_{DDA}$
Analog input voltage range, $V_{I(ANLG)}$	AGND to $V_{DDA}$
Digital input voltage range, $V_{I(DGTL)}$	DGND to $V_{DDD}$
Digital output voltage range, $V_{O(DGTL)}$	DGND to $V_{DDD}$
Operating free-air temperature range, $T_A$	–20°C to 75°C
Storage temperature range, $T_{stg}$	–55°C to 150°C

† Stresses beyond those listed under “absolute maximum ratings” may cause permanent damage to the device. These are stress ratings only, and functional operation of the device at these or any other conditions beyond those indicated under “recommended operating conditions” is not implied. Exposure to absolute-maximum-rated conditions for extended periods may affect device reliability.

### recommended operating conditions

		MIN	NOM	MAX	UNIT
Supply voltage	$V_{DDA}$ –AGND	4.75	5	5.25	V
	$V_{DDD}$ –AGND	4.75	5	5.25	
	AGND–DGND	–100	0	100	mV
Reference input voltage (top), $V_{ref(T)}^{\ddagger}$	TLC5510A	$V_{REFB}+2$		4	V
Reference input voltage (bottom), $V_{ref(B)}^{\ddagger}$	TLC5510A	0		$V_{REFT}-4$	V
Analog input voltage range, $V_{I(ANLG)}$		$V_{REFB}$		$V_{REFT}$	V
High-level input voltage, $V_{IH}$		4			V
Low-level input voltage, $V_{IL}$				1	V
Pulse duration, clock high, $t_{w(H)}$ (see Figure 1)		25			ns
Pulse duration, clock low, $t_{w(L)}$ (see Figure 1)		25			ns

‡ The reference voltage levels for the TLC5510 are derived through an internal resistor divider between  $V_{DDA}$  and ground and therefore are not derived from a separate external voltage source (see the electrical characteristics and text). For the 4 V input range of the TLC5510A, the reference voltage is externally applied across the center divider resistor.



# TLC5510, TLC5510A

## 8-BIT HIGH-SPEED ANALOG-TO-DIGITAL CONVERTERS

SLAS095L – SEPTEMBER 1994 – REVISED JUNE 2003

electrical characteristics at  $V_{DD} = 5\text{ V}$ ,  $V_{REFT} = 2.5\text{ V}$ ,  $V_{REFB} = 0.5\text{ V}$ ,  $f_{(CLK)} = 20\text{ MHz}$ ,  $T_A = 25^\circ\text{C}$  (unless otherwise noted)

### digital I/O

PARAMETER		TEST CONDITIONS†	MIN	TYP	MAX	UNIT
$I_{IH}$	High-level input current	$V_{DD} = \text{MAX}$ , $V_{IH} = V_{DD}$			5	$\mu\text{A}$
$I_{IL}$	Low-level input current	$V_{DD} = \text{MAX}$ , $V_{IL} = 0$			5	
$I_{OH}$	High-level output current	$\overline{OE} = \text{GND}$ , $V_{DD} = \text{MIN}$ , $V_{OH} = V_{DD} - 0.5\text{ V}$	-1.5			mA
$I_{OL}$	Low-level output current	$\overline{OE} = \text{GND}$ , $V_{DD} = \text{MIN}$ , $V_{OL} = 0.4\text{ V}$	2.5			
$I_{OZH}$	High-level high-impedance-state output leakage current	$\overline{OE} = V_{DD}$ , $V_{DD} = \text{MAX}$ , $V_{OH} = V_{DD}$			16	$\mu\text{A}$
$I_{OZL}$	Low-level high-impedance-state output leakage current	$\overline{OE} = V_{DD}$ , $V_{DD} = \text{MIN}$ , $V_{OL} = 0$			16	

† Conditions marked MIN or MAX are as stated in recommended operating conditions.

### power

PARAMETER		TEST CONDITIONS†	MIN	TYP	MAX	UNIT	
$I_{DD}$	Supply current	$f_{(CLK)} = 20\text{ MHz}$ , National Television System Committee (NTSC) ramp wave input, reference resistor dissipation is separate		18	27	mA	
$I_{ref}$	Reference voltage current	TLC5510	$V_{ref} = \text{REFT} - \text{REFB} = 2\text{ V}$	5.2	7.5	10.5	mA
		TLC5510A	$V_{ref} = \text{REFT} - \text{REFB} = 4\text{ V}$	10.4	15	21	mA

† Conditions marked MIN or MAX are as stated in recommended operating conditions.

### static performance

PARAMETER		TEST CONDITIONS†	MIN	TYP	MAX	UNIT	
Self-bias (1), at REFB		Short REFB to REFBS, Short REFT to REFTS	0.57	0.61	0.65	V	
Self-bias (2), REFT – REFB			1.9	2.02	2.15		
Self-bias (3), at REFT			2.18	2.29	2.4		
$R_{ref}$	Reference voltage resistor	Between REFT and REFB	190	270	350	$\Omega$	
$C_i$	Analog input capacitance	$V_{I(ANLG)} = 1.5\text{ V} + 0.07 V_{rms}$		16		pF	
Integral nonlinearity (INL)	TLC5510	$f_{(CLK)} = 20\text{ MHz}$ , $V_I = 0.5\text{ V to } 2.5\text{ V}$	$T_A = 25^\circ\text{C}$	$\pm 0.4$	$\pm 0.75$	LSB	
			$T_A = -20^\circ\text{C to } 75^\circ\text{C}$		$\pm 1$		
	TLC5510A	$f_{(CLK)} = 20\text{ MHz}$ , $V_I = 0\text{ to } 4\text{ V}$	$T_A = 25^\circ\text{C}$	$\pm 0.4$	$\pm 0.75$		
			$T_A = -20^\circ\text{C to } 75^\circ\text{C}$		$\pm 1$		
Differential nonlinearity (DNL)	TLC5510	$f_{(CLK)} = 20\text{ MHz}$ , $V_I = 0.5\text{ V to } 2.5\text{ V}$	$T_A = 25^\circ\text{C}$	$\pm 0.3$	$\pm 0.5$		
			$T_A = -20^\circ\text{C to } 75^\circ\text{C}$		$\pm 0.75$		
	TLC5510A	$f_{(CLK)} = 20\text{ MHz}$ , $V_I = 0\text{ to } 4\text{ V}$	$T_A = 25^\circ\text{C}$	$\pm 0.3$	$\pm 0.5$		
			$T_A = -20^\circ\text{C to } 75^\circ\text{C}$		$\pm 0.75$		
E <sub>ZS</sub>	Zero-scale error	TLC5510	$V_{ref} = \text{REFT} - \text{REFB} = 2\text{ V}$	-18	-43	-68	mV
		TLC5510A	$V_{ref} = \text{REFT} - \text{REFB} = 4\text{ V}$	-36	-86	-136	mV
E <sub>FS</sub>	Full-scale error	TLC5510	$V_{ref} = \text{REFT} - \text{REFB} = 2\text{ V}$	-20	0	20	mV
		TLC5510A	$V_{ref} = \text{REFT} - \text{REFB} = 4\text{ V}$	-40	0	40	mV

† Conditions marked MIN or MAX are as stated in recommended operating conditions.



# TLC5510, TLC5510A

## 8-BIT HIGH-SPEED ANALOG-TO-DIGITAL CONVERTERS

SLAS095L – SEPTEMBER 1994 – REVISED JUNE 2003

**operating characteristics at  $V_{DD} = 5\text{ V}$ ,  $V_{REFT} = 2.5\text{ V}$ ,  $V_{REFB} = 0.5\text{ V}$ ,  $f_{(CLK)} = 20\text{ MHz}$ ,  $T_A = 25^\circ\text{C}$  (unless otherwise noted)**

PARAMETER		TEST CONDITIONS		MIN	TYP	MAX	UNIT
$f_{conv}$	Maximum conversion rate	TLC5510	$f_I = 1\text{-kHz ramp}$			20	MSPS
		TLC5510A					
BW	Analog input bandwidth	$A_t - 1\text{ dB}$			14		MHz
$t_{d(D)}$	Digital output delay time	$C_L \leq 10\text{ pF}$ (see Note 1 and Figure 1)			18	30	ns
	Differential gain	NTSC 40 Institute of Radio Engineers (IRE) modulation wave, $f_{conv} = 14.3\text{ MSPS}$			1%		
	Differential phase				0.7	degrees	
$t_{AJ}$	Aperture jitter time				30		ps
$t_{d(s)}$	Sampling delay time				4		ns
$t_{en}$	Enable time, $\overline{OE} \downarrow$ to valid data	$C_L = 10\text{ pF}$			5		ns
$t_{dis}$	Disable time, $\overline{OE} \uparrow$ to high impedance	$C_L = 10\text{ pF}$			7		ns
Spurious free dynamic range (SFDR)		Input tone = 1 MHz	$T_A = 25^\circ\text{C}$		45		dB
			Full range		43		
		Input tone = 3 MHz	$T_A = 25^\circ\text{C}$		45		
			Full range		46		
		Input tone = 6 MHz	$T_A = 25^\circ\text{C}$		43		
			Full range		42		
		Input tone = 10 MHz	$T_A = 25^\circ\text{C}$		39		
			Full range		39		
SNR	Signal-to-noise ratio	$T_A = 25^\circ\text{C}$			46		dB
		Full range			44		

NOTE 1:  $C_L$  includes probe and jig capacitance.

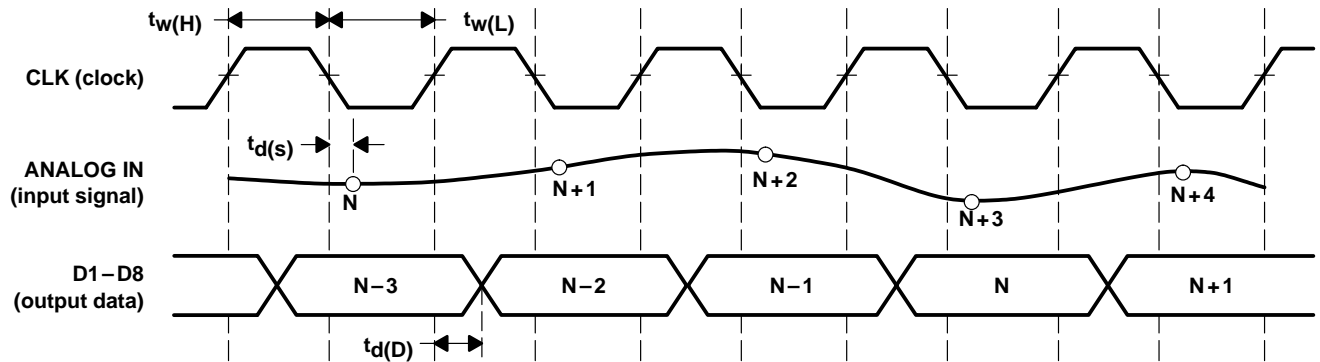

Figure 1. I/O Timing Diagram



# TLC5510, TLC5510A 8-BIT HIGH-SPEED ANALOG-TO-DIGITAL CONVERTERS

SLAS095L – SEPTEMBER 1994 – REVISED JUNE 2003

## PRINCIPLES OF OPERATION

### functional description

The TLC5510 and TLC5510A are semiflash ADCs featuring two lower comparator blocks of four bits each.

As shown in Figure 2, input voltage  $V_I(1)$  is sampled with the falling edge of CLK1 to the upper comparators block and the lower comparators block(A), S(1). The upper comparators block finalizes the upper data UD(1) with the rising edge of CLK2, and simultaneously, the lower reference voltage generates the voltage RV(1) corresponding to the upper data. The lower comparators block (A) finalizes the lower data LD(1) with the rising edge of CLK3. UD(1) and LD(1) are combined and output as OUT(1) with the rising edge of CLK4. As shown in Figure 2, the output data is delayed 2.5 clocks from the analog input voltage sampling point.

Input voltage  $V_I(2)$  is sampled with the falling edge of CLK2. UD(2) is finalized with the rising edge of CLK3, and LD(2) is finalized with the rising edge of CLK4 at the lower comparators block(B). OUT(2) data appears with the rising edge of CLK5.

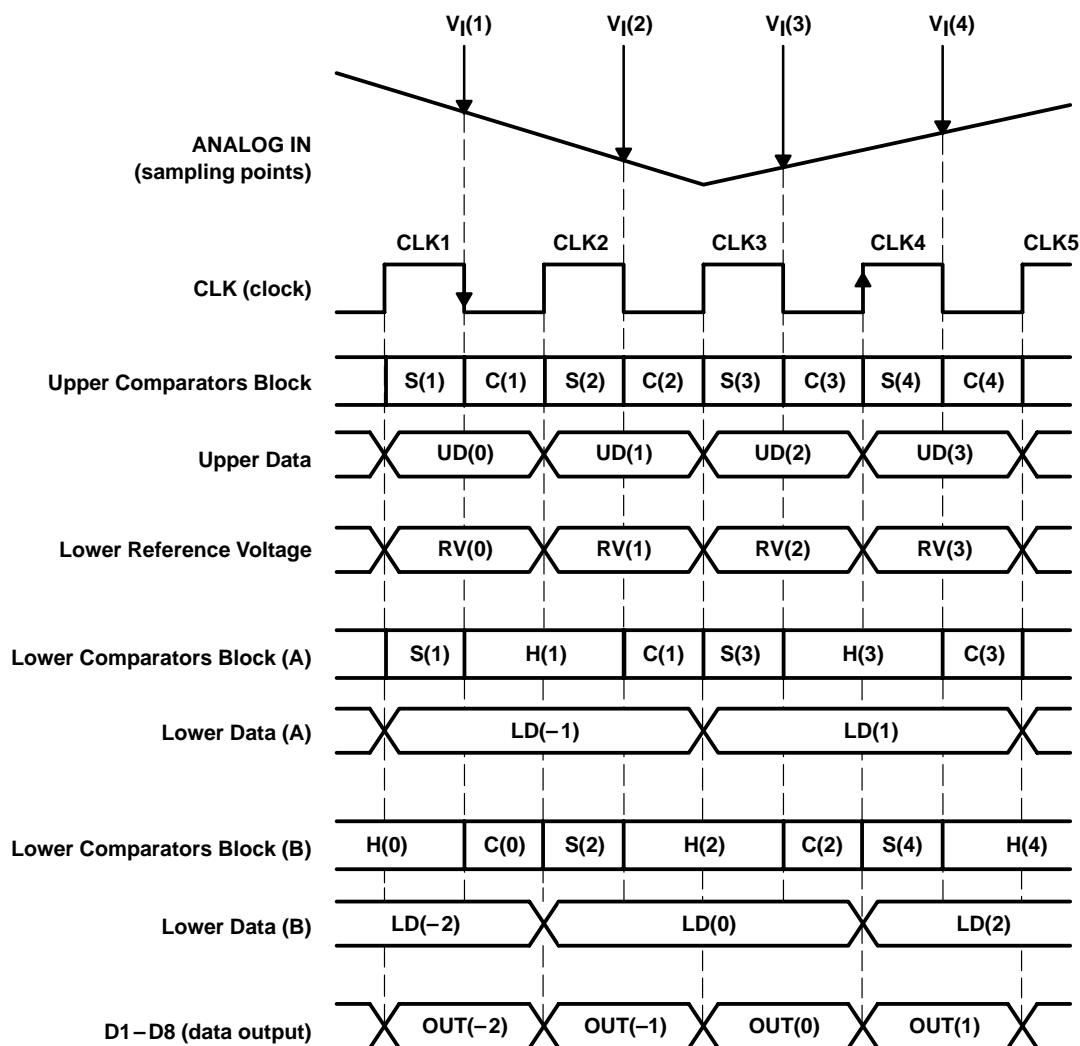

Figure 2. Internal Functional Timing Diagram

PRINCIPLES OF OPERATION

internal referencing

TLC5510

The three internal resistors shown with  $V_{DDA}$  can generate a 2-V reference voltage. These resistors are brought out on  $V_{DDA}$ , REFTS, REFT, REFB, REFBS, and AGND.

To use the internally generated reference voltage, terminal connections should be made as shown in Figure 3. This connection provides the standard video 2-V reference for the nominal digital output.

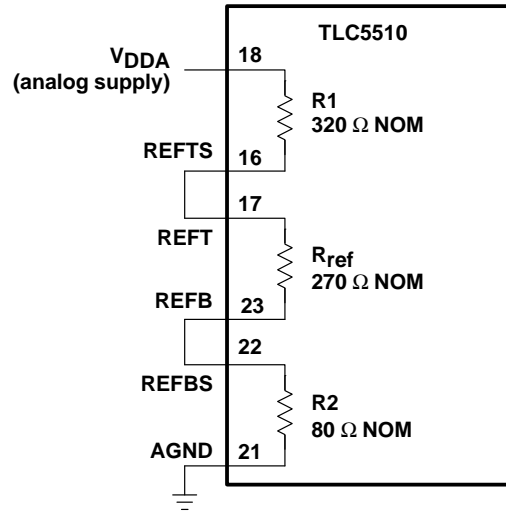

Figure 3. External Connections for a 2-V Analog Input Span Using the Internal-Reference Resistor Divider

TLC5510A

For an analog input span of 4 V, 4 V is supplied to REFT, and REFB is grounded and terminal connections should be made as shown in Figure 4. This connection provides the 4-V reference for the nominal zero to full-scale digital output with a 4  $V_{pp}$  analog input at ANALOG IN.

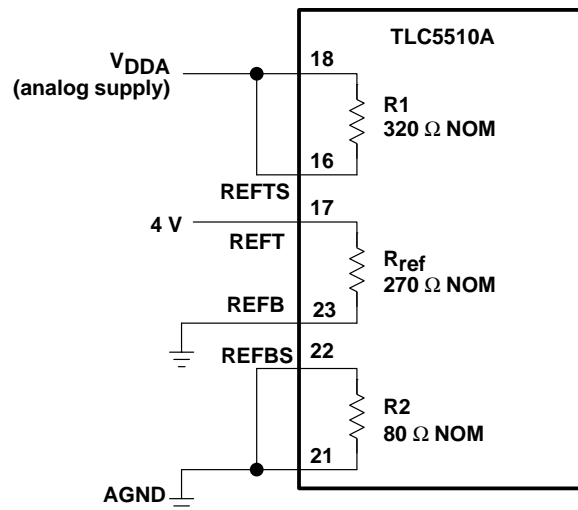

Figure 4. External Connections for 4-V Analog Input Span

# TLC5510, TLC5510A

## 8-BIT HIGH-SPEED ANALOG-TO-DIGITAL CONVERTERS

SLAS095L – SEPTEMBER 1994 – REVISED JUNE 2003

### PRINCIPLES OF OPERATION

#### functional operation

The output code change with input voltage is shown in Table 1.

Table 1. Functional Operation

INPUT SIGNAL VOLTAGE	STEP	DIGITAL OUTPUT CODE							
		MSB							LSB
$V_{ref(B)}$	255	0	0	0	0	0	0	0	0
•	•	•	•	•	•	•	•	•	•
•	•	•	•	•	•	•	•	•	•
•	128	0	1	1	1	1	1	1	1
•	127	1	0	0	0	0	0	0	0
•	•	•	•	•	•	•	•	•	•
•	•	•	•	•	•	•	•	•	•
$V_{ref(T)}$	0	1	1	1	1	1	1	1	1

### APPLICATION INFORMATION

The following notes are design recommendations that should be used with the device.

- External analog and digital circuitry should be physically separated and shielded as much as possible to reduce system noise.
- RF breadboarding or printed-circuit-board (PCB) techniques should be used throughout the evaluation and production process. Breadboards should be copper clad for bench evaluation.
- Since AGND and DGND are connected internally, the ground lead in must be kept as noise free as possible. A good method to use is twisted-pair cables for the supply lines to minimize noise pickup. An analog and digital ground plane should be used on PCB layouts when additional logic devices are used. The AGND and DGND terminals of the device should be tied to the analog ground plane.
- $V_{DDA}$  to AGND and  $V_{DDD}$  to DGND should be decoupled with 1- $\mu$ F and 0.01- $\mu$ F capacitors, respectively, and placed as close as possible to the affected device terminals. A ceramic-chip capacitor is recommended for the 0.01- $\mu$ F capacitor. Care should be exercised to ensure a solid noise-free ground connection for the analog and digital ground terminals.
- $V_{DDA}$ , AGND, and ANALOG IN should be shielded from the higher frequency terminals, CLK and D0–D7. When possible, AGND traces should be placed on both sides of the ANALOG IN traces on the PCB for shielding.
- In testing or application of the device, the resistance of the driving source connected to the analog input should be 10  $\Omega$  or less within the analog frequency range of interest.



# TLC5510, TLC5510A 8-BIT HIGH-SPEED ANALOG-TO-DIGITAL CONVERTERS

SLAS095L – SEPTEMBER 1994 – REVISED JUNE 2003

## APPLICATION INFORMATION

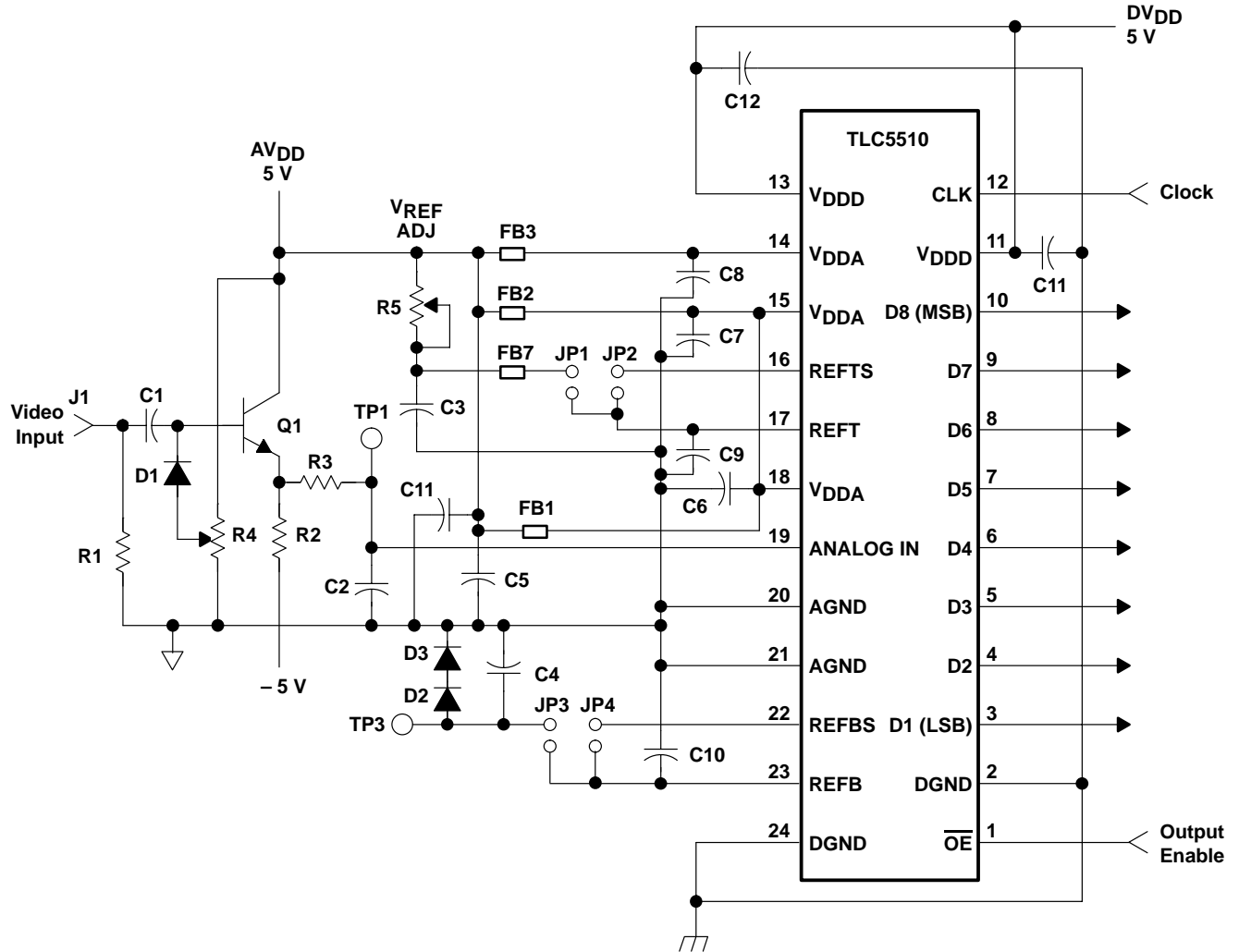

NOTE A: Shorting JP1 and JP3 allows adjustment of the reference voltage by R5 using temperature-compensating diodes D2 and D3 which compensate for D1 and Q1 variations. By shorting JP2 and JP4, the internal divider generates a nominal 2-V reference.

LOCATION	DESCRIPTION
C1, C3–C4, C6–C12	0.1- $\mu$ F capacitor
C2	10-pF capacitor
C5	47- $\mu$ F capacitor
FB1, FB2, FB3, FB7	Ferrite bead
Q1	2N3414 or equivalent
R1, R3	75- $\Omega$ resistor
R2	500- $\Omega$ resistor
R4	10-k $\Omega$ resistor, clamp voltage adjust
R5	300- $\Omega$ resistor, reference-voltage fine adjust

Figure 5. TLC5510 Evaluation and Test Schematic

# TLC5510, TLC5510A 8-BIT HIGH-SPEED ANALOG-TO-DIGITAL CONVERTERS

SLAS095L – SEPTEMBER 1994 – REVISED JUNE 2003

## APPLICATION INFORMATION

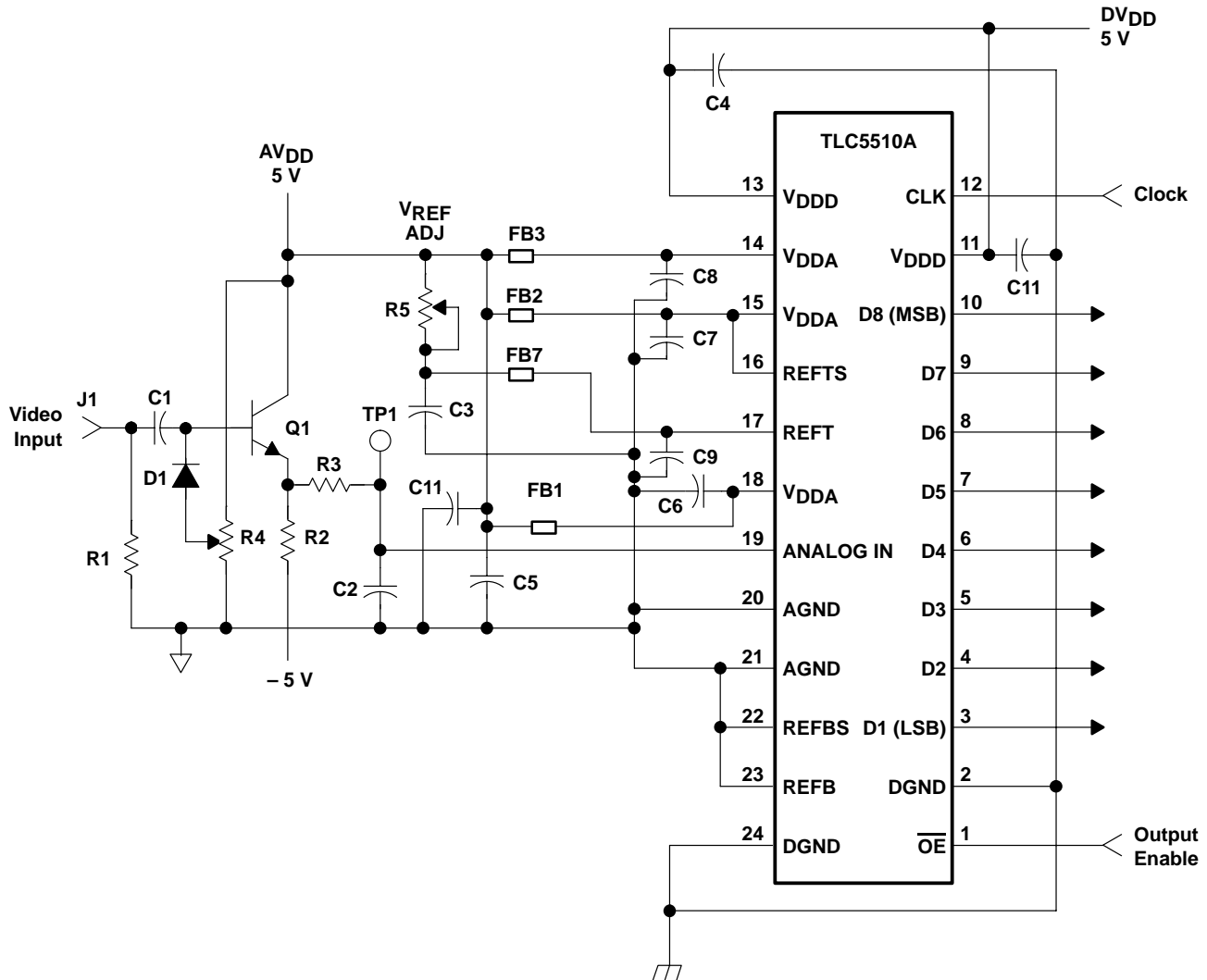

NOTE A: R5 allows adjustment of the reference voltage to 4 V. R4 adjusts for the desired Q1 quiescent operating point.

LOCATION	DESCRIPTION
C1, C3–C4, C6–C11	0.1- $\mu$ F capacitor
C2	10-pF capacitor
C5	47- $\mu$ F capacitor
FB1, FB2, FB3, FB7	Ferrite bead
Q1	2N3414 or equivalent
R1, R3	75- $\Omega$ resistor
R2	500- $\Omega$ resistor
R4	10-k $\Omega$ resistor, clamp voltage adjust
R5	300- $\Omega$ resistor, reference-voltage fine adjust

Figure 6. TLC5510A Evaluation and Test Schematic

APPLICATION INFORMATION

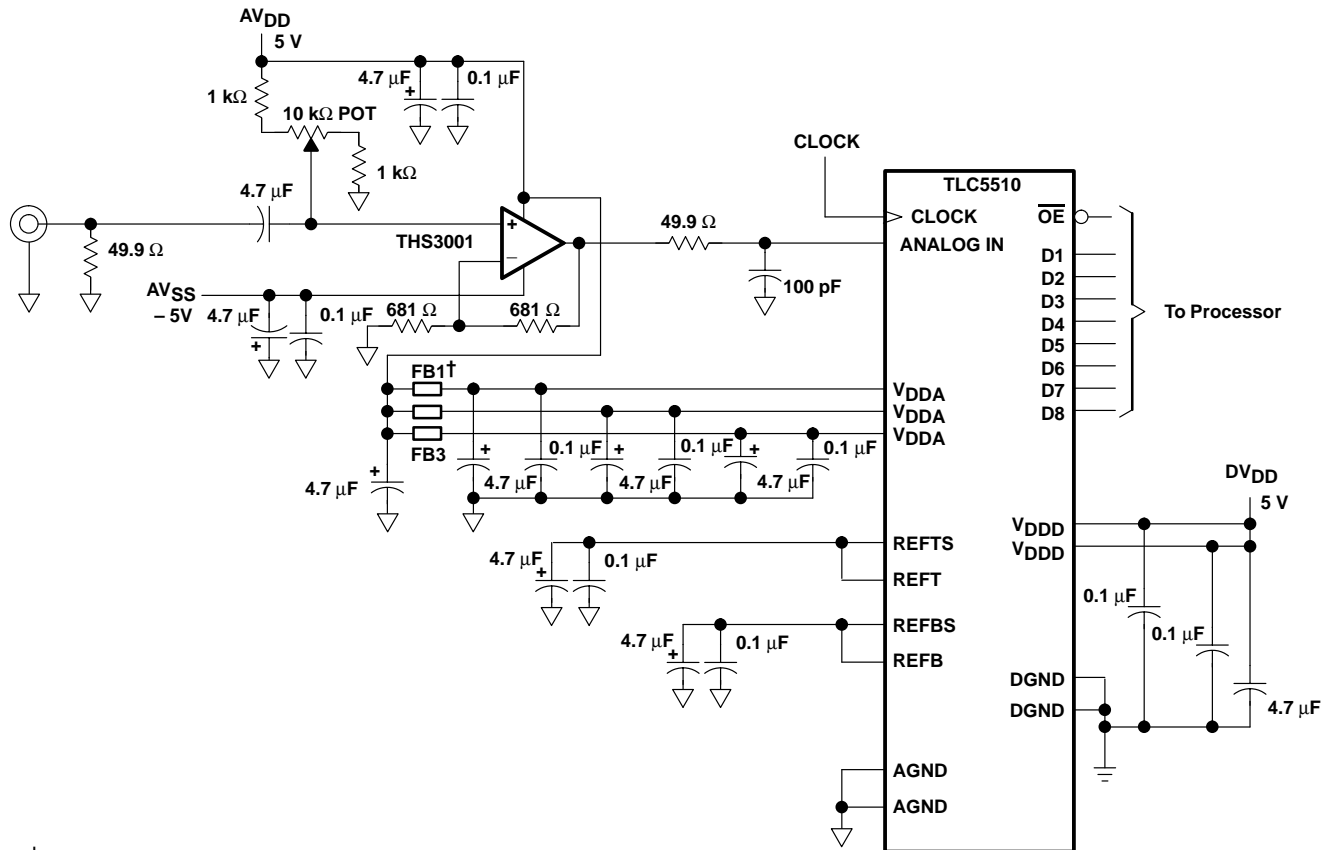

† FB – Ferrite Bead

Figure 7. TLC5510 Application Schematic

# TLC5510, TLC5510A 8-BIT HIGH-SPEED ANALOG-TO-DIGITAL CONVERTERS

SLAS095L – SEPTEMBER 1994 – REVISED JUNE 2003

## APPLICATION INFORMATION

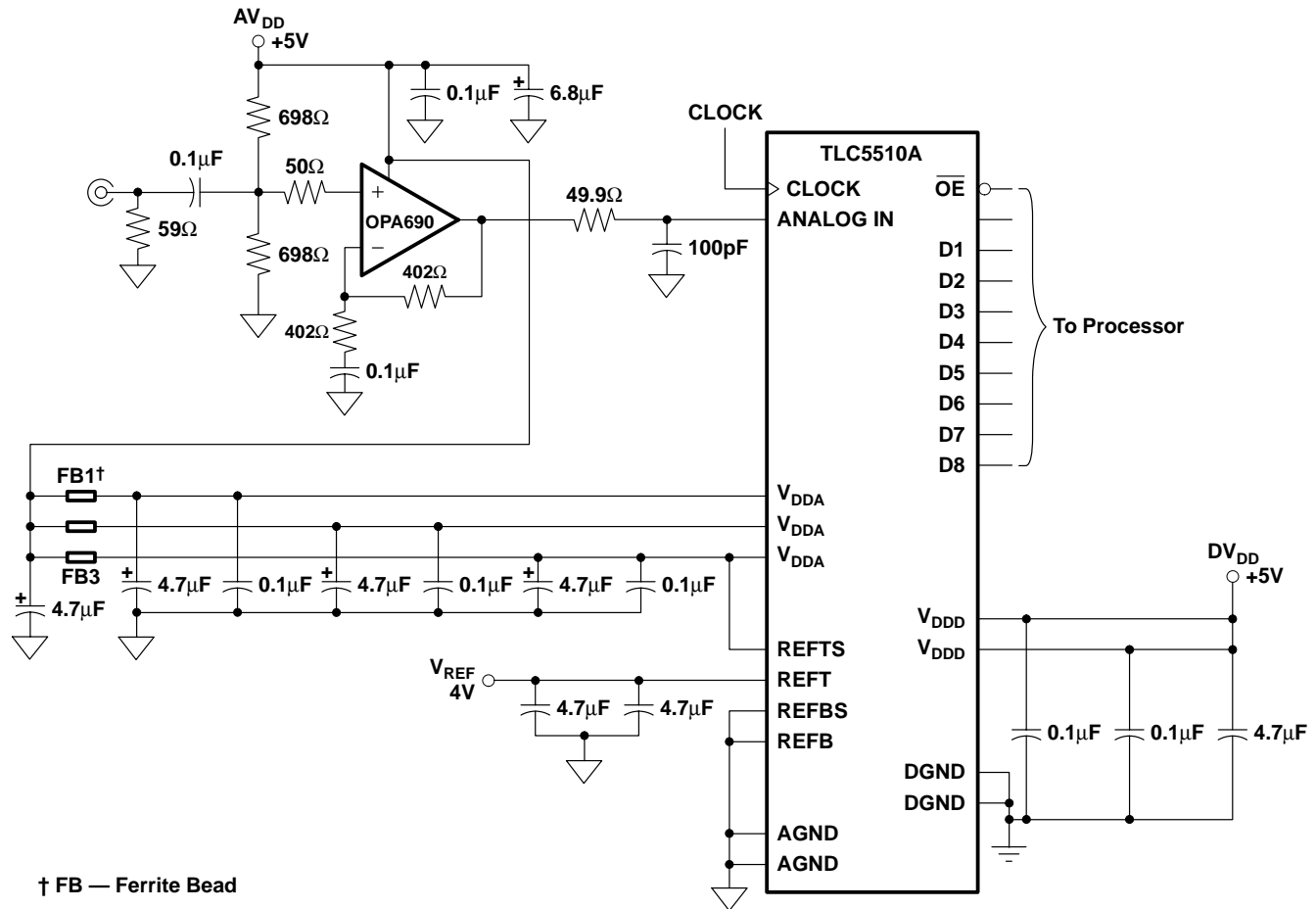

Figure 8. TLC5510A Application Schematic

**PACKAGING INFORMATION**

Orderable Device	Status (1)	Package Type	Package Drawing	Pins	Package Qty	Eco Plan (2)	Lead finish/ Ball material (6)	MSL Peak Temp (3)	Op Temp (°C)	Device Marking (4/5)	Samples
TLC5510AINS	ACTIVE	SO	NS	24	34	RoHS & Green	NIPDAU	Level-1-260C-UNLIM	-20 to 75	TLC5510AI	<a href="#">Samples</a>
TLC5510AINSR	ACTIVE	SO	NS	24	2000	RoHS & Green	NIPDAU	Level-1-260C-UNLIM	-20 to 75	TLC5510AI	<a href="#">Samples</a>
TLC5510INS	ACTIVE	SO	NS	24	34	RoHS & Green	NIPDAU	Level-1-260C-UNLIM	-20 to 75	TLC5510I	<a href="#">Samples</a>
TLC5510INSR	ACTIVE	SO	NS	24	2000	RoHS & Green	NIPDAU	Level-1-260C-UNLIM	-20 to 75	TLC5510I	<a href="#">Samples</a>
TLC5510IPW	ACTIVE	TSSOP	PW	24	60	RoHS & Green	NIPDAU	Level-2-260C-1 YEAR	-20 to 75	Y5510	<a href="#">Samples</a>
TLC5510IPWR	ACTIVE	TSSOP	PW	24	2000	RoHS & Green	NIPDAU	Level-2-260C-1 YEAR	-20 to 75	Y5510	<a href="#">Samples</a>

(1) The marketing status values are defined as follows:

**ACTIVE:** Product device recommended for new designs.

**LIFEBUY:** TI has announced that the device will be discontinued, and a lifetime-buy period is in effect.

**NRND:** Not recommended for new designs. Device is in production to support existing customers, but TI does not recommend using this part in a new design.

**PREVIEW:** Device has been announced but is not in production. Samples may or may not be available.

**OBSOLETE:** TI has discontinued the production of the device.

(2) **RoHS:** TI defines "RoHS" to mean semiconductor products that are compliant with the current EU RoHS requirements for all 10 RoHS substances, including the requirement that RoHS substance do not exceed 0.1% by weight in homogeneous materials. Where designed to be soldered at high temperatures, "RoHS" products are suitable for use in specified lead-free processes. TI may reference these types of products as "Pb-Free".

**RoHS Exempt:** TI defines "RoHS Exempt" to mean products that contain lead but are compliant with EU RoHS pursuant to a specific EU RoHS exemption.

**Green:** TI defines "Green" to mean the content of Chlorine (Cl) and Bromine (Br) based flame retardants meet JS709B low halogen requirements of <=1000ppm threshold. Antimony trioxide based flame retardants must also meet the <=1000ppm threshold requirement.

(3) MSL, Peak Temp. - The Moisture Sensitivity Level rating according to the JEDEC industry standard classifications, and peak solder temperature.

(4) There may be additional marking, which relates to the logo, the lot trace code information, or the environmental category on the device.

(5) Multiple Device Markings will be inside parentheses. Only one Device Marking contained in parentheses and separated by a "~" will appear on a device. If a line is indented then it is a continuation of the previous line and the two combined represent the entire Device Marking for that device.

(6) Lead finish/Ball material - Orderable Devices may have multiple material finish options. Finish options are separated by a vertical ruled line. Lead finish/Ball material values may wrap to two lines if the finish value exceeds the maximum column width.

**Important Information and Disclaimer:** The information provided on this page represents TI's knowledge and belief as of the date that it is provided. TI bases its knowledge and belief on information provided by third parties, and makes no representation or warranty as to the accuracy of such information. Efforts are underway to better integrate information from third parties. TI has taken and continues to take reasonable steps to provide representative and accurate information but may not have conducted destructive testing or chemical analysis on incoming materials and chemicals. TI and TI suppliers consider certain information to be proprietary, and thus CAS numbers and other limited information may not be available for release.

In no event shall TI's liability arising out of such information exceed the total purchase price of the TI part(s) at issue in this document sold by TI to Customer on an annual basis.

**TAPE AND REEL INFORMATION**

**QUADRANT ASSIGNMENTS FOR PIN 1 ORIENTATION IN TAPE**



\*All dimensions are nominal

Device	Package Type	Package Drawing	Pins	SPQ	Reel Diameter (mm)	Reel Width W1 (mm)	A0 (mm)	B0 (mm)	K0 (mm)	P1 (mm)	W (mm)	Pin1 Quadrant
TLC5510AINSR	SO	NS	24	2000	330.0	24.4	8.5	15.3	2.6	12.0	24.0	Q1
TLC5510INSR	SO	NS	24	2000	330.0	24.4	8.5	15.3	2.6	12.0	24.0	Q1
TLC5510IPWR	TSSOP	PW	24	2000	330.0	16.4	6.95	8.3	1.6	8.0	16.0	Q1

**TAPE AND REEL BOX DIMENSIONS**

\*All dimensions are nominal

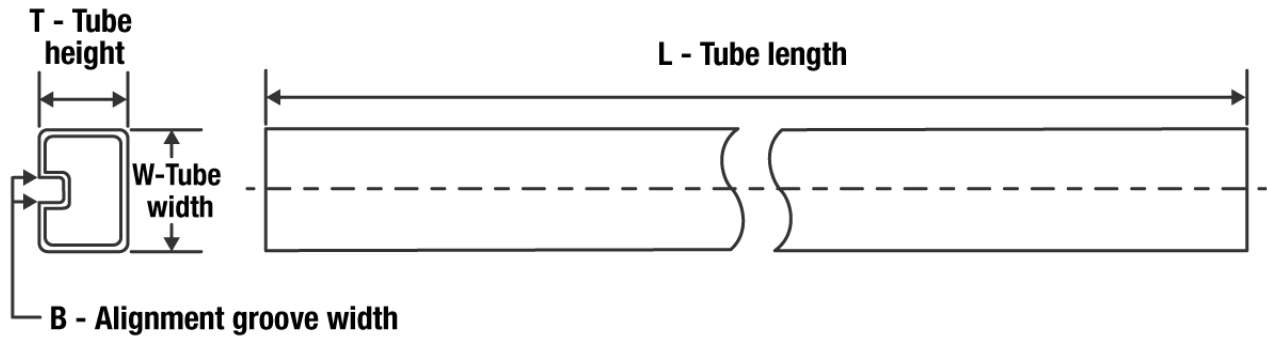
Device	Package Type	Package Drawing	Pins	SPQ	Length (mm)	Width (mm)	Height (mm)
TLC5510AINSR	SO	NS	24	2000	350.0	350.0	43.0
TLC5510INSR	SO	NS	24	2000	350.0	350.0	43.0
TLC5510IPWR	TSSOP	PW	24	2000	350.0	350.0	43.0

**TUBE**

\*All dimensions are nominal

Device	Package Name	Package Type	Pins	SPQ	L (mm)	W (mm)	T (μm)	B (mm)
TLC5510AINS	NS	SOP	24	34	530	10.5	4000	4.1
TLC5510INS	NS	SOP	24	34	530	10.5	4000	4.1
TLC5510IPW	PW	TSSOP	24	60	530	10.2	3600	3.5



# EXAMPLE BOARD LAYOUT

PW0024A

TSSOP - 1.2 mm max height

SMALL OUTLINE PACKAGE

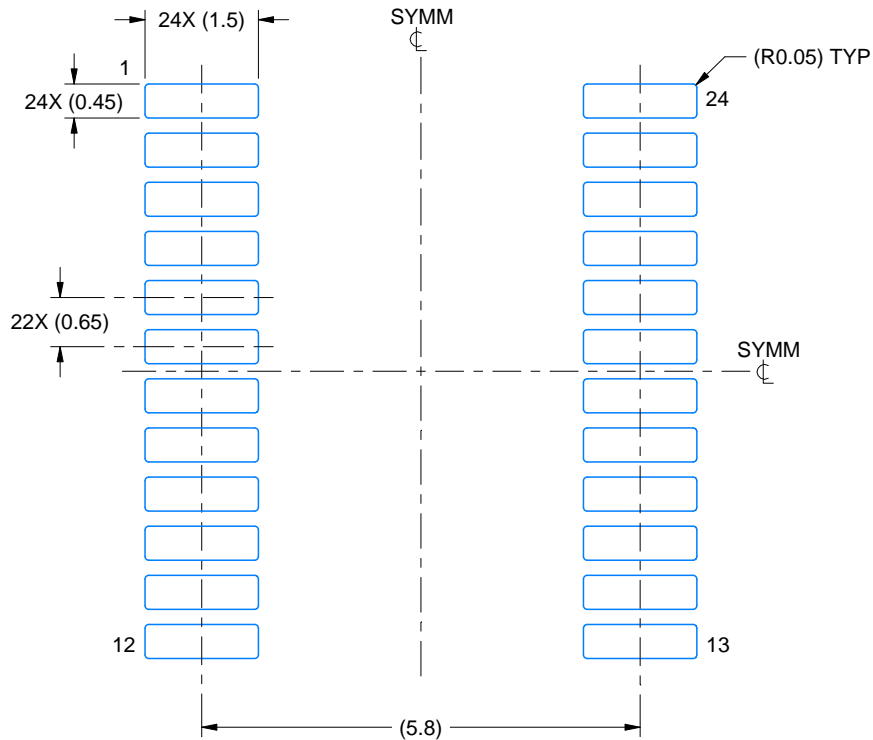

LAND PATTERN EXAMPLE  
EXPOSED METAL SHOWN  
SCALE: 10X

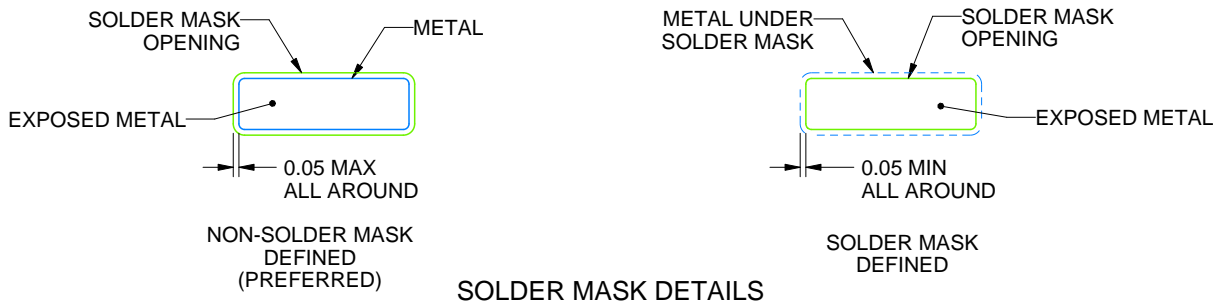

SOLDER MASK DETAILS

4220208/A 02/2017

NOTES: (continued)

- 6. Publication IPC-7351 may have alternate designs.
- 7. Solder mask tolerances between and around signal pads can vary based on board fabrication site.

# EXAMPLE STENCIL DESIGN

PW0024A

TSSOP - 1.2 mm max height

SMALL OUTLINE PACKAGE

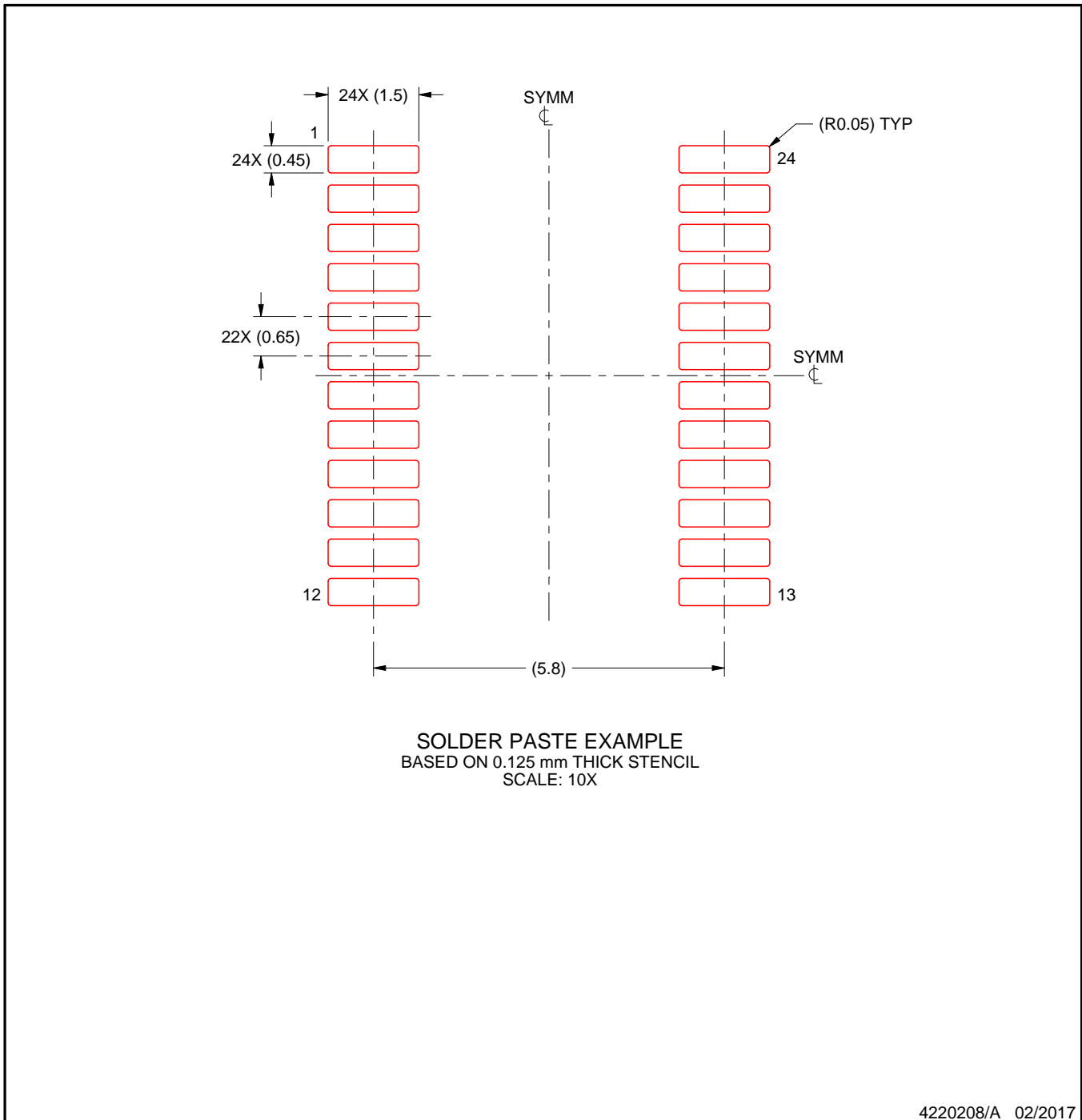

NOTES: (continued)

8. Laser cutting apertures with trapezoidal walls and rounded corners may offer better paste release. IPC-7525 may have alternate design recommendations.
9. Board assembly site may have different recommendations for stencil design.

# MECHANICAL DATA

NS (R-PDSO-G\*\*)

PLASTIC SMALL-OUTLINE PACKAGE

14-PINS SHOWN



- NOTES:
- A. All linear dimensions are in millimeters.
  - B. This drawing is subject to change without notice.
  - C. Body dimensions do not include mold flash or protrusion, not to exceed 0,15.

## IMPORTANT NOTICE AND DISCLAIMER

TI PROVIDES TECHNICAL AND RELIABILITY DATA (INCLUDING DATA SHEETS), DESIGN RESOURCES (INCLUDING REFERENCE DESIGNS), APPLICATION OR OTHER DESIGN ADVICE, WEB TOOLS, SAFETY INFORMATION, AND OTHER RESOURCES "AS IS" AND WITH ALL FAULTS, AND DISCLAIMS ALL WARRANTIES, EXPRESS AND IMPLIED, INCLUDING WITHOUT LIMITATION ANY IMPLIED WARRANTIES OF MERCHANTABILITY, FITNESS FOR A PARTICULAR PURPOSE OR NON-INFRINGEMENT OF THIRD PARTY INTELLECTUAL PROPERTY RIGHTS.

These resources are intended for skilled developers designing with TI products. You are solely responsible for (1) selecting the appropriate TI products for your application, (2) designing, validating and testing your application, and (3) ensuring your application meets applicable standards, and any other safety, security, regulatory or other requirements.

These resources are subject to change without notice. TI grants you permission to use these resources only for development of an application that uses the TI products described in the resource. Other reproduction and display of these resources is prohibited. No license is granted to any other TI intellectual property right or to any third party intellectual property right. TI disclaims responsibility for, and you will fully indemnify TI and its representatives against, any claims, damages, costs, losses, and liabilities arising out of your use of these resources.

TI's products are provided subject to [TI's Terms of Sale](#) or other applicable terms available either on [ti.com](http://ti.com) or provided in conjunction with such TI products. TI's provision of these resources does not expand or otherwise alter TI's applicable warranties or warranty disclaimers for TI products.

TI objects to and rejects any additional or different terms you may have proposed.

Mailing Address: Texas Instruments, Post Office Box 655303, Dallas, Texas 75265  
Copyright © 2022, Texas Instruments Incorporated