

## HD3SS3412 4 通道高性能差分开关

### 1 特性

- 与运行在速率高达 12Gbps 的多种接口标准（其中包括 PCI 快速三代 (Express GEN III) 和 USB 3.0）兼容
- 8GHz 频率范围内具有 -3dB 宽差分带宽 (BW)
- 出色动态特性 (4GHz 时)
  - 串扰 = -35dB
  - 断开隔离 = -19dB
  - 插入损耗 = -1.5dB
  - 回波损耗 = -11dB
- 双向 "MUX/De-MUX" 类型差动开关
- 漏极电源电压 (VDD) 运行范围  $3.3V \pm 10\%$
- 3.5mm x 9.0mm、42 引脚晶圆级四方扁平无引线 (WQFN) 小型封装
- 共同工业标准引脚分配
- 支持 XAUI 和 SGMII

### 2 应用

- 台式机和笔记本电脑
- 服务器和存储局域网络
- PCI Express 背板
- 共享 I/O 端口

### 3 说明

HD3SS3412 器件是一款高速无源开关，能够切换四条差分通道，包括在 PC/服务器应用中将两条完整 PCI Express x1 信道从一个源切换到两个目标位置之一。凭借双向功能，HD3SS3412 还支持一个目标设备与两个源设备相连，例如两个平台共享同一外设。

HD3SS3412 具备一个单一控制线路 (SEL 引脚)，可用于控制端口 A 与端口 B 或者端口 C 之间的信号路径。

HD3SS3412 采用符合行业标准的 42 引脚 WQFN 封装，封装尺寸与其他几家供应商提供的器件相同。该器件需要在  $-40^{\circ}\text{C}$  至  $85^{\circ}\text{C}$  的完整温度范围内由电压为 3.3V 的单电源供电运行。

器件信息<sup>(1)</sup>

器件型号	封装	封装尺寸 (标称值)
HD3SS3412	WQFN (42)	9.00mm x 3.50mm

(1) 要了解所有可用封装，请参见数据表末尾的可订购产品附录。

HD3SS3412 引脚分配

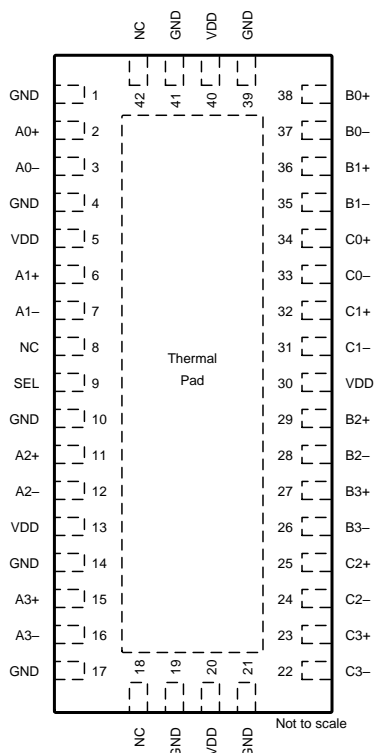

HD3SS3412 开关直通布线

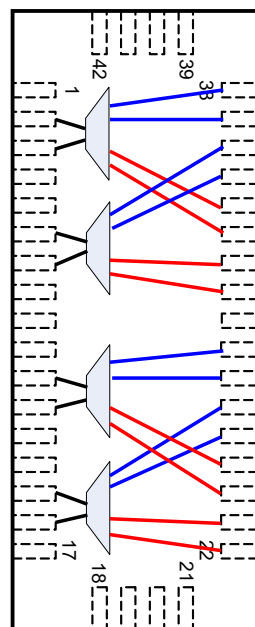

## 目录

<p>1 特性 ..... 1</p> <p>2 应用 ..... 1</p> <p>3 说明 ..... 1</p> <p>4 修订历史记录 ..... 2</p> <p>5 说明 (续) ..... 4</p> <p>6 <b>Pin Configuration and Functions</b> ..... 5</p> <p>7 <b>Specifications</b> ..... 7</p> <p style="padding-left: 20px;">7.1 Absolute Maximum Ratings ..... 7</p> <p style="padding-left: 20px;">7.2 ESD Ratings ..... 7</p> <p style="padding-left: 20px;">7.3 Recommended Operating Conditions ..... 7</p> <p style="padding-left: 20px;">7.4 Thermal Information ..... 7</p> <p style="padding-left: 20px;">7.5 Electrical Characteristics ..... 8</p> <p style="padding-left: 20px;">7.6 Dissipation Ratings ..... 8</p> <p style="padding-left: 20px;">7.7 Typical Characteristics ..... 10</p> <p>8 <b>Parameter Measurement Information</b> ..... 11</p> <p>9 <b>Detailed Description</b> ..... 13</p> <p style="padding-left: 20px;">9.1 Overview ..... 13</p>	<p>9.2 Functional Block Diagram ..... 13</p> <p>9.3 Feature Description ..... 14</p> <p>9.4 Device Functional Modes ..... 14</p> <p>10 <b>Application and Implementation</b> ..... 15</p> <p style="padding-left: 20px;">10.1 Application Information ..... 15</p> <p style="padding-left: 20px;">10.2 Typical Application ..... 16</p> <p>11 <b>Power Supply Recommendations</b> ..... 18</p> <p>12 <b>Layout</b> ..... 18</p> <p style="padding-left: 20px;">12.1 Layout Guidelines ..... 18</p> <p style="padding-left: 20px;">12.2 Layout Example ..... 18</p> <p>13 <b>器件和文档支持</b> ..... 19</p> <p style="padding-left: 20px;">13.1 接收文档更新通知 ..... 19</p> <p style="padding-left: 20px;">13.2 社区资源 ..... 19</p> <p style="padding-left: 20px;">13.3 商标 ..... 19</p> <p style="padding-left: 20px;">13.4 静电放电警告 ..... 19</p> <p style="padding-left: 20px;">13.5 术语表 ..... 19</p> <p>14 <b>机械、封装和可订购信息</b> ..... 19</p>
---	---

### 4 修订历史记录

注：之前版本的页码可能与当前版本有所不同。

<b>Changes from Revision E (January 2015) to Revision F</b>	<b>Page</b>
• 将温度范围从 0°C 到 70°C 更改为 -40°C 到 85°C。 .....	1
• Changed T <sub>A</sub> To: -40°C MIN and 85°C MAX From: 0°C MIN and 70°C MAX in the <i>Recommended Operating Conditions</i> table .....	7
• Changed the P <sub>D</sub> values From: MIN = 15.5, MAX = 21.6 To: MIN = 2.8, MAX = 4.4 in the <i>Dissipation Ratings</i> table .....	8
<b>Changes from Revision D (December 2015) to Revision E</b>	<b>Page</b>
• Changed "over the full industrial temperature range of -40°C to 70°C" To: "over the commercial temperature range of 0°C to 70°C" in the <a href="#">Overview</a> section .....	13
<b>Changes from Revision C (July 2015) to Revision D</b>	<b>Page</b>
• Changed "full industrial temperature range of -40°C to 85°C" To: "full industrial temperature range of 0°C to 70°C" in the <a href="#">Overview</a> section .....	13
<b>Changes from Revision B (November 2013) to Revision C</b>	<b>Page</b>
• 已添加 引脚配置和功能 部分、ESD 额定值表、特性说明 部分、器件功能模式、应用和实施 部分、电源相关建议 部分、布局 部分、器件和文档支持 部分以及机械、封装和可订购信息 部分 .....	1
• 已删除订购信息表 .....	1
<b>Changes from Revision A (February 2012 ) to Revision B</b>	<b>Page</b>
• 已添加 额外特性：双向“复用/解复用” ("MUX/de-MUX") 差动开关 .....	1
• 已添加此器件支持 XAUI 和 SGMII 的内容 .....	1
• 已更改 温度范围“-40°C 至 85°C”至“0°C 至 70°C”并删除了说明部分中的“工业”部分添加了 EDI 固件功能列表 .....	1
• Changed pin description of NC From: Electrically not connected. To: Electrically not connected. May connect to VDD or GND, or leave unconnected .....	6

- Added the *Application Information* section ..... 15

**Changes from Original (January 2012 ) to Revision A**
**Page**

• 已更改 将差分 BW 特性着要点由“7.5GHZ”改为“8GHz” .....	1
• 已更改 将动态特性子着重号从“隔离”改为“断开隔离” .....	1
• 已更改 将动态特性子着重号回波损耗从“-9dB”改为“-11dB” .....	1
• 已删除 动态特性子着重号“最大内部对（位-位）偏斜” .....	1
• Changed ESD, Human body model, MAX voltage from “±2000” to “±4,000” in Absolute Maximum Ratings table .....	7
• Changed I <sub>LK</sub> spec (Diff I/O pins) MAX value from “4 μA” to “130 μA” and added [Ports B and C] and [Port A] to Conditions statements. ....	8
• Changed t <sub>PD</sub> spec MAX delay from “50” ps to “85” ps in Device Parameters table.....	8
• Changed SEL-to-switch T <sub>on</sub> and T <sub>off</sub> spec TYP values from “175” ns to “70” ns; in the Device Parameters table.....	8
• Changed T <sub>SKEW_Inter</sub> and T <sub>SKEW_Intra</sub> spec MAX values from “5 ps” and “4 ps” respectively, to “20 ps” and “8 ps” respectively, in Electrical Characteristics table.....	8
• Changed R <sub>L</sub> spec TYP value from “-25” and “-9” dB to “-28” and “-11” dB for f=0.3 MHz and f=4000 MHz, respectively, in Electrical Characteristics table. ....	8
• Changed O <sub>IRR</sub> spec TYP value from “-70” to “-75” dB for f=0.3 MHz, in Electrical Characteristics table. ....	8
• Changed BW spec TYP value from “7.5” GHz to “8” GHz in Electrical Characteristics table. ....	8
• Changed graphic image for <a href="#">Figure 3</a> .....	10
• Changed graphic image for <a href="#">Figure 4</a> .....	10

## 5 说明（续）

HD3SS3412 是一款通用四通道高速复用/解复用型开关，可用于在电路板上的两个不同位置间路由高速信号。虽然 HD3SS3412 专为 PCI Express Gen III 应用而设计，但如同 USB 3.0 和 DisplayPort 1.2 一样，它也支持多种差动幅度小于 1800 mVpp 且共模电压小于 2V 的其他高速数据协议。该器件的一个选择输入 (SEL) 引脚可通过系统内或微控制器提供的一个 GPIO 引脚轻松控制。

## 6 Pin Configuration and Functions

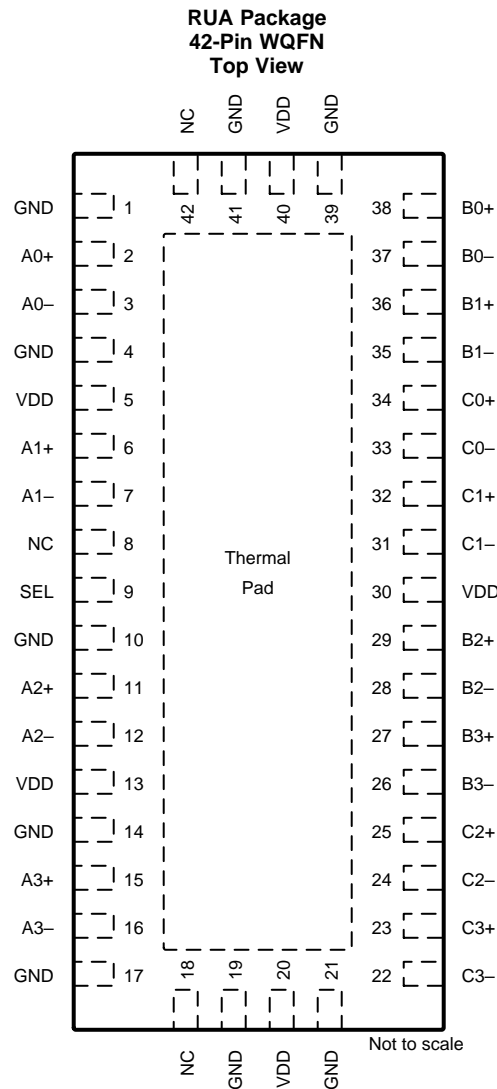

### Pin Functions

PIN		I/O	DESCRIPTION
NAME	NO.		
<b>SWITCH PORT A</b>			
A0+	2	I/O	Port A, Channel 0, High-Speed Positive Signal
A0-	3	I/O	Port A, Channel 0, High-Speed Negative Signal
A1+	6	I/O	Port A, Channel 1, High-Speed Positive Signal
A1-	7	I/O	Port A, Channel 1, High-Speed Negative Signal
A2+	11	I/O	Port A, Channel 2, High-Speed Positive Signal
A2-	12	I/O	Port A, Channel 2, High-Speed Negative Signal
A3+	15	I/O	Port A, Channel 3, High-Speed Positive Signal
A3-	16	I/O	Port A, Channel 3, High-Speed Negative Signal
<b>SWITCH PORT B</b>			
B0+	38	I/O	Port B, Channel 0, High-Speed Positive Signal
B0-	37	I/O	Port B, Channel 0, High-Speed Negative Signal

**Pin Functions (continued)**

PIN		I/O	DESCRIPTION
NAME	NO.		
B1+	36	I/O	Port B, Channel 1, High-Speed Positive Signal
B1–	35	I/O	Port B, Channel 1, High-Speed Negative Signal
B2+	29	I/O	Port B, Channel 2, High-Speed Positive Signal
B2–	28	I/O	Port B, Channel 2, High-Speed Negative Signal
B3+	27	I/O	Port B, Channel 3, High-Speed Positive Signal
B3–	26	I/O	Port B, Channel 3, High-Speed Negative Signal
<b>SWITCH PORT C</b>			
C0+	34	I/O	Port C, Channel 0, High-Speed Positive Signal
C0–	33	I/O	Port C, Channel 0, High-Speed Negative Signal
C1+	32	I/O	Port C, Channel 1, High-Speed Positive Signal
C1–	31	I/O	Port C, Channel 1, High-Speed Negative Signal
C2+	25	I/O	Port C, Channel 2, High-Speed Positive Signal
C2–	24	I/O	Port C, Channel 2, High-Speed Negative Signal
C3+	23	I/O	Port C, Channel 3, High-Speed Positive Signal
C3–	22	I/O	Port C, Channel 3, High-Speed Negative Signal
<b>CONTROL, SUPPLY, AND NO CONNECT</b>			
NC	8	—	Electrically not connected. May connect to VDD or GND, or leave unconnected.
	18		
	42		
GND	1	Supply	Negative power supply voltage
	4		
	10		
	14		
	17		
	19		
	21		
	39		
	41		
Center Pad			
SEL	9	I	Select between port B or port C. Internally tied to GND through a 100-kΩ resistor
VDD	5	Supply	Positive power supply voltage
	13		
	20		
	30		
	40		

## 7 Specifications

### 7.1 Absolute Maximum Ratings

Over operating free-air temperature range (unless otherwise noted)<sup>(1)(2)</sup>

		MIN	MAX	UNIT
Supply voltage (V <sub>DD</sub> )	Absolute minimum/maximum supply voltage	-0.5	4	V
Voltage	Differential I/O	-0.5	4	V
	Control pin (SEL)	-0.5	V <sub>DD</sub> + 0.5	
Storage temperature, T <sub>stg</sub>		-65	150	°C

- (1) Stresses beyond those listed under *Absolute Maximum Ratings* may cause permanent damage to the device. These are stress ratings only and functional operation of the device at these or any conditions beyond those indicated under *Recommended Operating Conditions* is not implied. Exposure to absolute-maximum-rated conditions for extended periods may affect device reliability.
- (2) All voltage values, except differential voltages, are with respect to network ground terminal.

### 7.2 ESD Ratings

		VALUE	UNIT
V <sub>(ESD)</sub> Electrostatic discharge	Human-body model (HBM), per ANSI/ESDA/JEDEC JS-001 <sup>(1)</sup>	±4000	V
	Charged-device model (CDM), per JEDEC specification JESD22-C101 <sup>(2)</sup>	±1500	

- (1) JEDEC document JEP155 states that 500-V HBM allows safe manufacturing with a standard ESD control process.
- (2) JEDEC document JEP157 states that 250-V CDM allows safe manufacturing with a standard ESD control process.

### 7.3 Recommended Operating Conditions

Typical values for all parameters are at V<sub>DD</sub> = 3.3 V and T<sub>A</sub> = 25°C. (Temperature limits are specified by design)

		MIN	NOM	MAX	UNIT	
V <sub>DD</sub>	Supply voltage	3	3.3	3.6	V	
V <sub>IH</sub>	Input high voltage (SEL pin)	2		V <sub>DD</sub>	V	
V <sub>IL</sub>	Input low voltage (SEL pin)	-0.1		0.8	V	
V <sub>I/O_Diff</sub>	Differential voltage (differential pins)	Switch I/O diff voltage		1.8	V <sub>PP</sub>	
V <sub>I/O_CM</sub>	Common voltage (differential pins)	Switch I/O common-mode voltage		2	V	
T <sub>A</sub>	Operating free-air temperature	Ambient temperature		-40	85	°C

### 7.4 Thermal Information

THERMAL METRIC <sup>(1)</sup>		HD3SS3412	UNIT
		RUA (WQFN)	
		42 PINS	
R <sub>θJA</sub>	Junction-to-ambient thermal resistance	53.8	°C/W
R <sub>θJC(top)</sub>	Junction-to-case (top) thermal resistance	38.2	°C/W
R <sub>θJB</sub>	Junction-to-board thermal resistance	21.9	°C/W
ψ <sub>JT</sub>	Junction-to-top characterization parameter	27.4	°C/W
ψ <sub>JB</sub>	Junction-to-board characterization parameter	5.6	°C/W
R <sub>θJC(bot)</sub>	Junction-to-case (bottom) thermal resistance	27.3	°C/W

- (1) For more information about traditional and new thermal metrics, see the [Semiconductor and IC Package Thermal Metrics](#) application report.

## 7.5 Electrical Characteristics

Over operating free-air temperature range (unless otherwise noted)

PARAMETER		TEST CONDITIONS	MIN	TYP	MAX	UNIT
<b>DEVICE PARAMETERS</b>						
$I_{IH}$	Input High Voltage (SEL)	$V_{DD} = 3.6\text{ V}; V_{IN} = V_{DD}$			95	$\mu\text{A}$
$I_{IL}$	Input Low Voltage (SEL)	$V_{DD} = 3.6\text{ V}; V_{IN} = \text{GND}$			1	$\mu\text{A}$
$I_{LK}$	Leakage Current (Differential I/O pins)	$V_{DD} = 3.6\text{ V}; V_{IN} = 0\text{ V}; V_{OUT} = 2\text{ V}$ ( $I_{LK}$ On OPEN outputs) [Ports B and C]			130	$\mu\text{A}$
		$V_{DD} = 3.6\text{ V}; V_{IN} = 2\text{ V}; V_{OUT} = 0\text{ V}$ ( $I_{LK}$ On OPEN outputs) [Port A]			4	
$I_{DD}$	Supply Current	$V_{DD} = 3.6\text{ V}; \text{SEL} = V_{DD}/\text{GND}; \text{Outputs Floating}$		4.7	6	mA
$C_{ON}$	Outputs ON Capacitance	$V_{IN} = 0\text{ V}; \text{Outputs Open}; \text{Switch ON}$		1.5		pF
$C_{OFF}$	Outputs OFF Capacitance	$V_{IN} = 0\text{ V}; \text{Outputs Open}, \text{Switch OFF}$		1		pF
$R_{ON}$	Output ON resistance	$V_{DD} = 3.3\text{ V}; V_{CM} = 0.5\text{ V to } 1.5\text{ V}; I_O = -8\text{ mA}$		5	8	$\Omega$
$\Delta R_{ON}$	ON-resistance match between channels	$V_{DD} = 3.3\text{ V}; -0.35\text{ V} \leq V_{IN} \leq 1.2\text{ V}; I_O = -8\text{ mA}$			2	$\Omega$
	ON-resistance match between pairs of the same channel	$V_{DD} = 3.3\text{ V}; -0.35\text{ V} \leq V_{IN} \leq 1.2\text{ V}; I_O = -8\text{ mA}$			0.7	$\Omega$
$R_{FLAT\_ON}$	ON-resistance flatness ( $R_{ON(MAX)} - R_{ON(MAIN)}$ )	$V_{DD} = 3.3\text{ V}; -0.35\text{ V} \leq V_{IN} \leq 1.2\text{ V}$			1.15	$\Omega$
$t_{PD}$	Switch propagation delay	$R_{sc}$ and $R_{LOAD} = 50\ \Omega$			85	ps
	SEL-to-switch $T_{ON}$	$R_{sc}$ and $R_{LOAD} = 50\ \Omega$		70	250	ns
	SEL-to-switch $T_{OFF}$			70	250	
$T_{SKEW\_Inter}$	Inter-pair output skew (CH-CH)	$R_{sc}$ and $R_{LOAD} = 50\ \Omega$			20	ps
$T_{SKEW\_Intra}$	Intra-pair output skew (bit-bit)	$R_{sc}$ and $R_{LOAD} = 50\ \Omega$			8	ps
$R_L$	Differential return loss ( $V_{CM} = 0\text{ V}$ ) Also see <a href="#">Typical Characteristics</a>	$f = 0.3\text{ MHz}$		-28		dB
		$f = 2500\text{ MHz}$		-12		
		$f = 4000\text{ MHz}$		-11		
$X_{TALK}$	Differential Crosstalk ( $V_{CM} = 0\text{ V}$ ) Also see <a href="#">Typical Characteristics</a>	$f = 0.3\text{ MHz}$		-90		dB
		$f = 2500\text{ MHz}$		-39		
		$f = 4000\text{ MHz}$		-35		
$O_{IRR}$	Differential Off-Isolation ( $V_{CM} = 0\text{ V}$ ) Also see <a href="#">Typical Characteristics</a>	$f = 0.3\text{ MHz}$		-75		dB
		$f = 2500\text{ MHz}$		-22		
		$f = 4000\text{ MHz}$		-19		
$I_L$	Differential Insertion Loss ( $V_{CM} = 0\text{ V}$ ) Also see <a href="#">Typical Characteristics</a>	$f = 0.3\text{ MHz}$		-0.5		dB
		$f = 2500\text{ MHz}$		-1.1		
		$f = 4000\text{ MHz}$		-1.5		
BW	Bandwidth	At -3 dB		8		GHz

## 7.6 Dissipation Ratings

		MIN	MAX	UNIT
$P_D$	Power Dissipation	2.8	4.4	mW

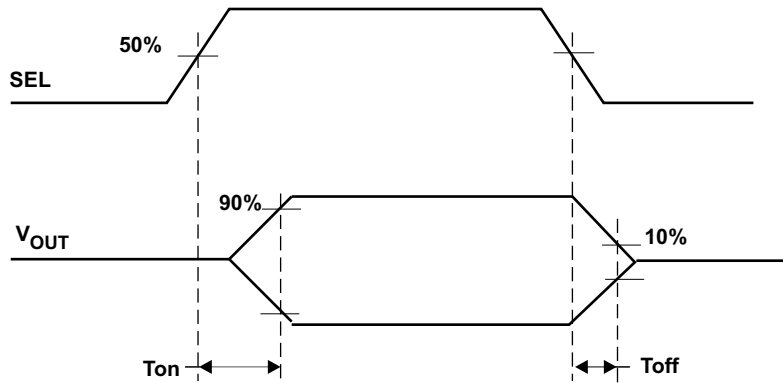
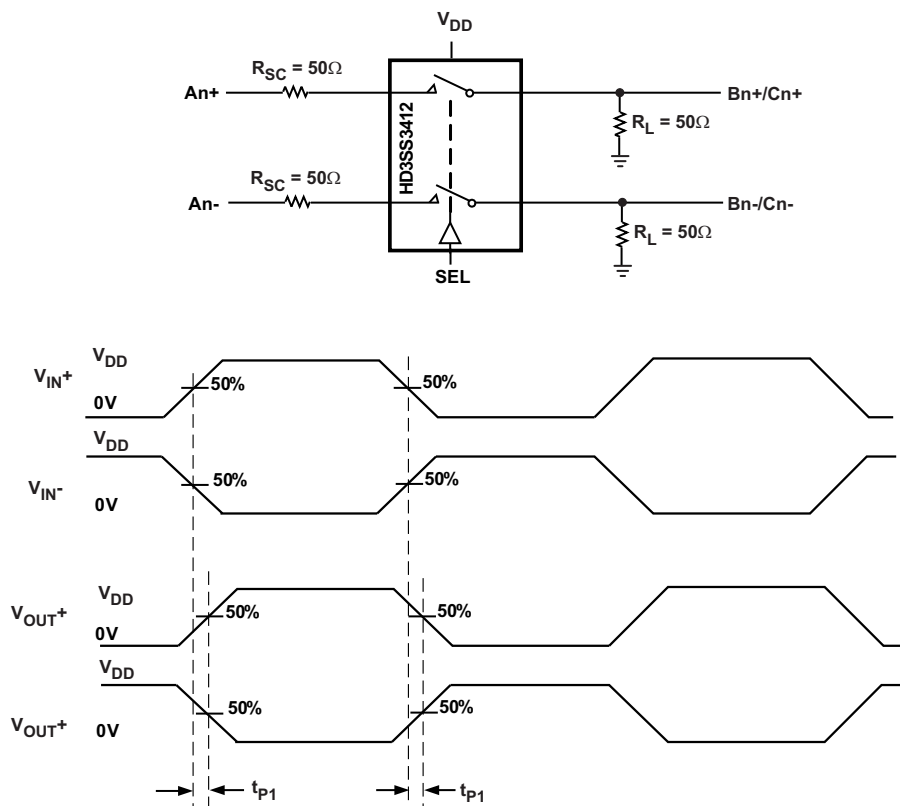

Figure 1. Switch ON and OFF Timing Diagram



$T_{\text{SKEWInter}}$  = Difference between  $t_{\text{PD}}$  for any two pairs of outputs

$T_{\text{SKEWIntra}}$  = Difference between  $t_{\text{P1}}$  and  $t_{\text{P2}}$  of same pair

Figure 2. Propagation Delay Timing Diagram and Test Setup

### 7.7 Typical Characteristics

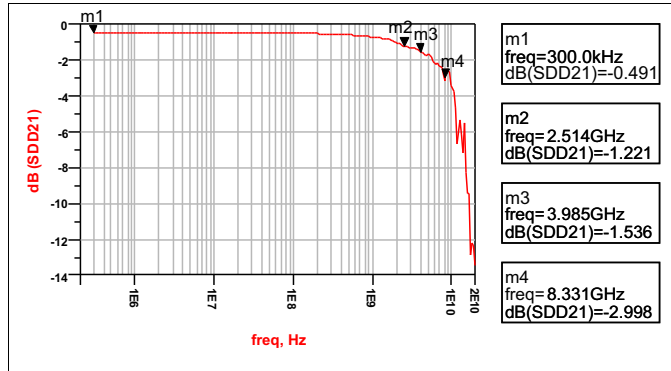

Figure 3. Differential Insertion Loss

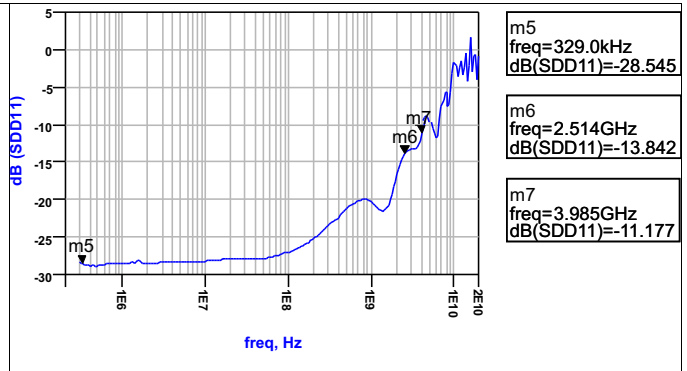

Figure 4. Differential Return Loss

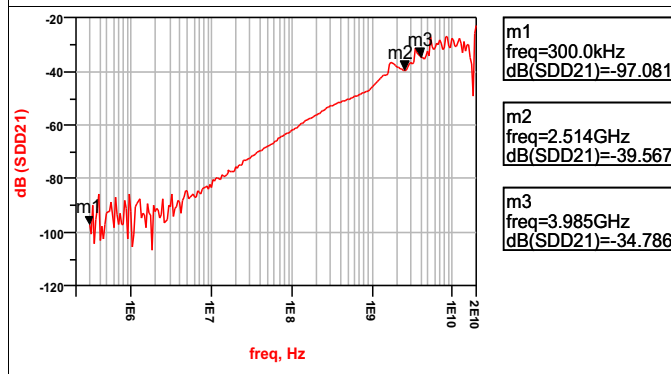

Figure 5. Differential Crosstalk

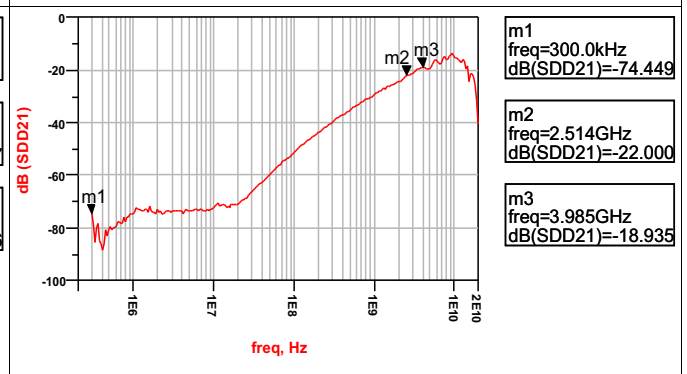

Figure 6. Differential Off Isolation

## 8 Parameter Measurement Information

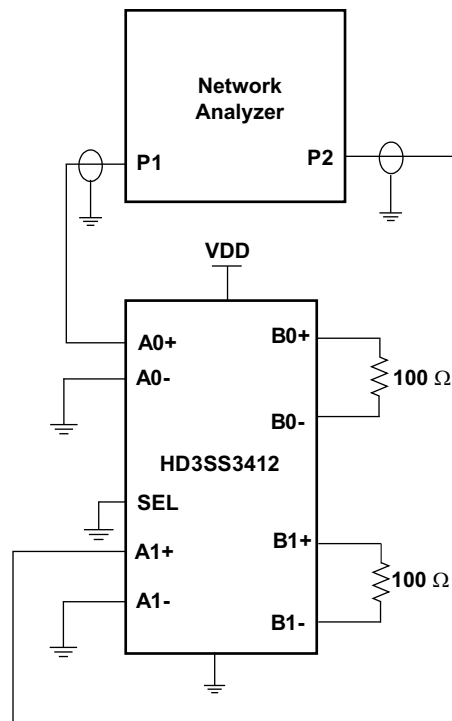

Figure 7. Cross Talk Measurement Setup

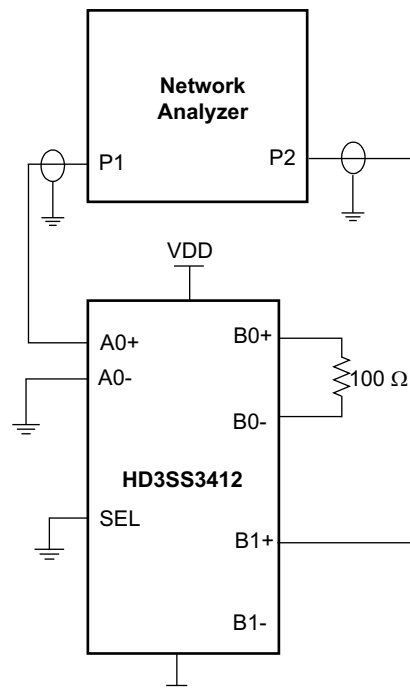
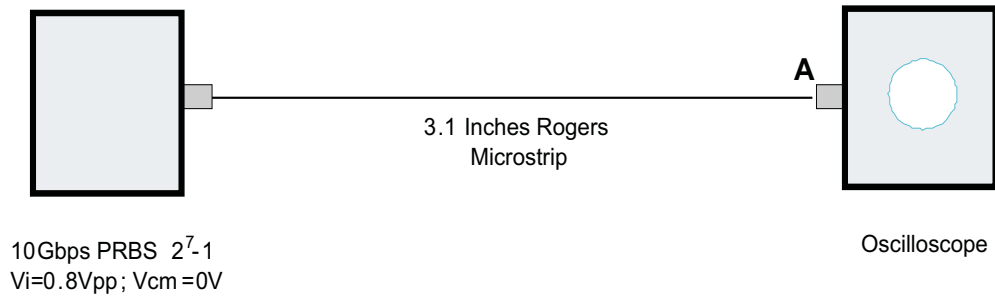
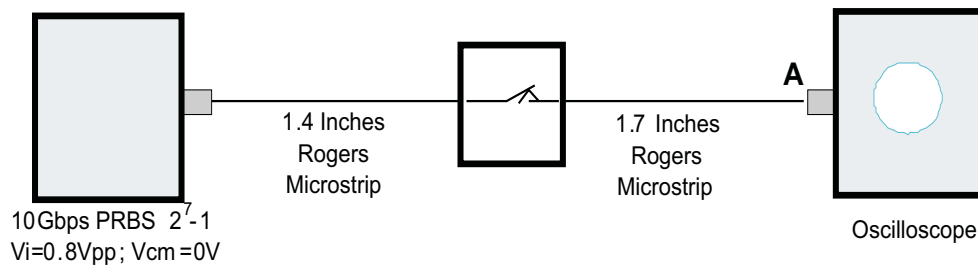

Figure 8. Off Isolation Measurement Setup

**Parameter Measurement Information (continued)**



**Figure 9. Source Eye Diagram Test Setup**



**Figure 10. Output Eye Diagram Test Setup**

## 9 Detailed Description

### 9.1 Overview

The HD3SS3412 is a high-speed passive switch offered in an industry standard 42-pin WQFN package available in a common footprint shared by several other vendors. The device is specified to operate from a single supply voltage of 3.3 V over the commercial temperature range of 0°C to 70°C. The HD3SS3412 is a generic 4-CH high-speed mux/demux type of switch that can be used for routing high-speed PCI signals between two different locations on a circuit board. Although it was designed specifically to address PCI Express Gen III applications, the HD3SS3412 will also support several other high-speed data protocols with a differential amplitude of < 1800 mVpp and a common-mode voltage of < 2.0 V, as with USB 3.0 and DisplayPort 1.2. The device's one select input (SEL) pin can easily be controlled by an available GPIO pin within a system or from a microcontroller.

### 9.2 Functional Block Diagram

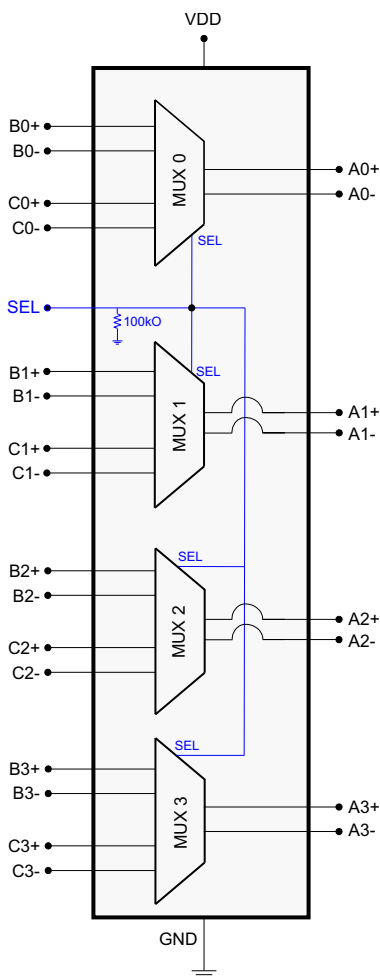

### 9.3 Feature Description

The HD3SS3412 has a single control line (SEL Pin) which can be used to control the signal path between Port A and either Port B or Port C. The one select input (SEL) pin of the device can easily be controlled by an available GPIO pin within a system or from a microcontroller. The input signal is selected using the SEL pin.

**Table 1. Mux Pin Connections<sup>(1)</sup>**

PORT A CHANNEL	PORT B OR PORT C CHANNEL CONNECTED TO PORT A CHANNEL	
	SEL = L	SEL = H
A0+	B0+	C0+
A0–	B0–	C0–
A1+	B1+	C1+
A1–	B1–	C1–
A2+	B2+	C2+
A2–	B2–	C2–
A3+	B3+	C3+
A3–	B3–	C3–

(1) The HD3SS3412 can tolerate polarity inversions for all differential signals on Ports A, B, and C. Take care to ensure the same polarity is maintained on Port A versus Port B/C.

### 9.4 Device Functional Modes

Table 2 lists the functional modes for the HD3SS3412.

**Table 2. HD3SS3412 Control Logic**

CONTROL PIN (SEL)	PORT A TO PORT B CONNECTION STATUS	PORT A TO PORT C CONNECTION STATUS
L (Default State)	Connected	Disconnected
H	Disconnected	Connected

## 10 Application and Implementation

### NOTE

Information in the following applications sections is not part of the TI component specification, and TI does not warrant its accuracy or completeness. TI's customers are responsible for determining suitability of components for their purposes. Customers should validate and test their design implementation to confirm system functionality.

### 10.1 Application Information

#### 10.1.1 AC Coupling Caps

Many interfaces require AC coupling between the transmitter and receiver. The 0402 capacitors are the preferred option to provide AC coupling, and the 0603 size capacitors also work. The 0805 size capacitors and C-packs should be avoided. When placing AC coupling capacitors symmetric placement is best. A capacitor value of 0.1  $\mu$ F is best and the value should be match for the  $\pm$  signal pair. The placement should be along the TX pairs on the system board, which are usually routed on the top layer of the board.

There are several placement options for the AC coupling capacitors. Because the switch requires a bias voltage, the capacitors must only be placed on one side of the switch. If they are placed on both sides of the switch, a biasing voltage should be provided. A few placement options are shown below. In Figure 11, the coupling capacitors are placed between the switch and endpoint. In this situation, the switch is biased by the system/host controller.

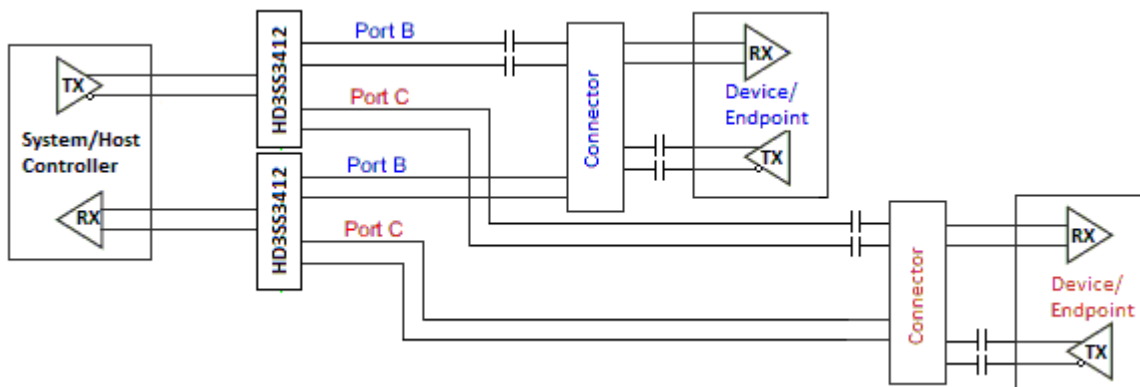

Figure 11. AC Coupling Capacitors Between Switch Tx and Endpoint Tx

In Figure 12, the coupling capacitors are placed on the host transmit pair and endpoint transmit pair. In this situation, the switch on the top is biased by the endpoint and the lower switch is biased by the host controller.

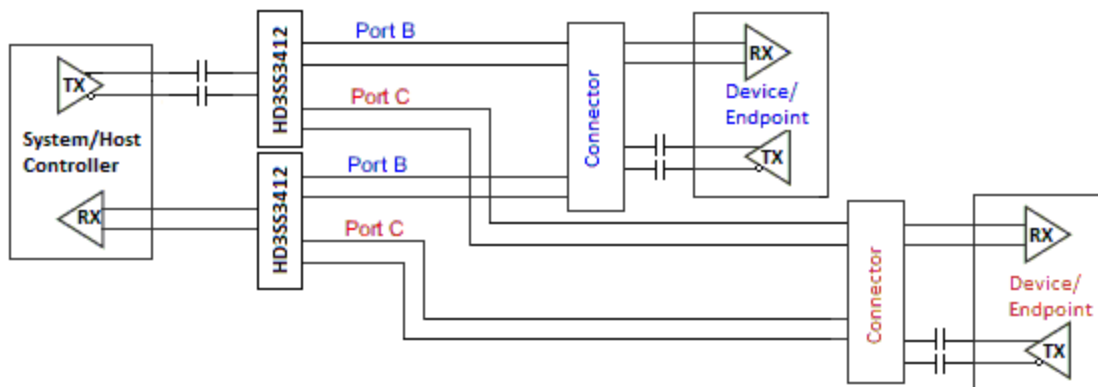

Figure 12. AC Coupling Capacitors on Host Tx and Endpoint Tx

### Application Information (continued)

If the common-mode voltage in the system is higher than 2 V, the coupling capacitors are placed on both sides of the switch (shown in Figure 13). A biasing voltage of less than 2 V is required in this case.

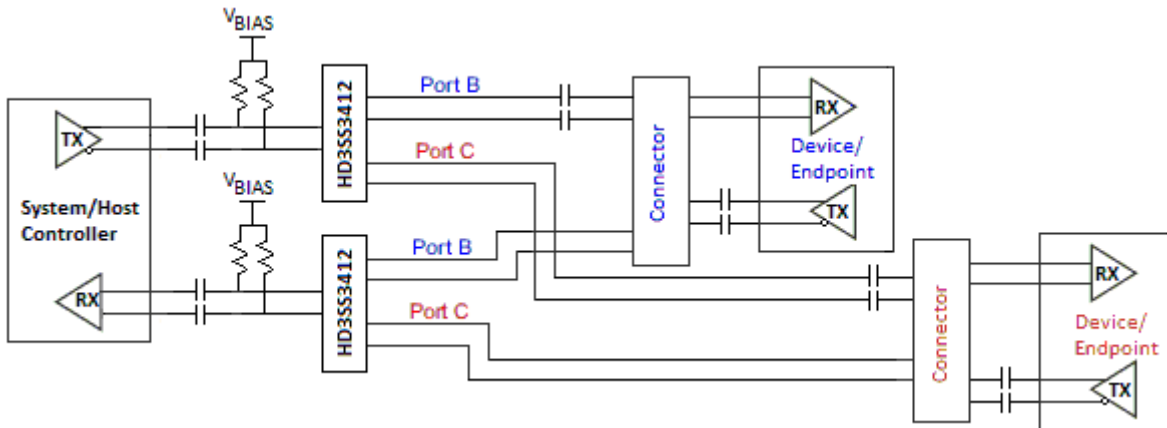

Figure 13. AC Coupling Capacitors on Both Sides of Switch

## 10.2 Typical Application

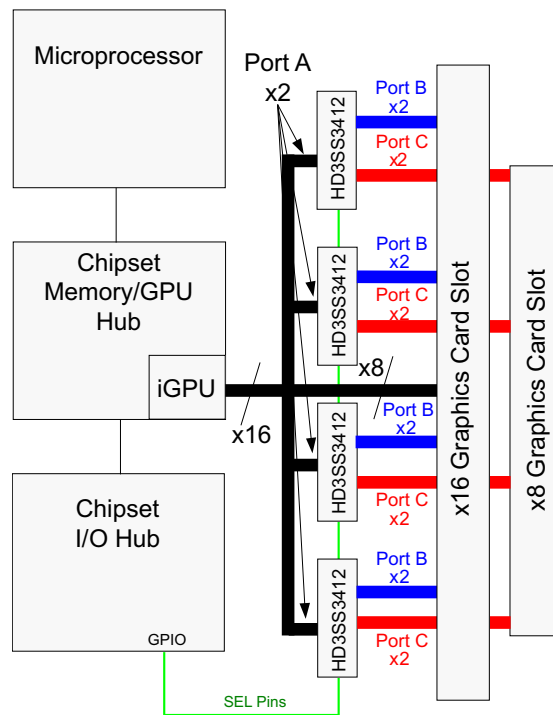

Figure 14. Typical Application Block Diagram

## Typical Application (continued)

### 10.2.1 Design Requirements

Table 3 lists the design parameters of this example.

Table 3. Design Parameters

DESIGN PARAMETERS	EXAMPLE VALUE
Input voltage range	3.3 V
Decoupling capacitors	0.1 $\mu$ F
AC capacitors	75 nF – 200 nF (100 nF shown) USBAA TX p and n lines require AC capacitors. Alternate mode signals may or may not require AC capacitors

### 10.2.2 Detailed Design Procedure

- Connect VDD and GND pins to the power and ground planes of the printed circuit board, with 0.1-uF bypass capacitor
- Use +3.3-V TTL/CMOS logic level at SEL
- Use controlled-impedance transmission media for all the differential signals
- Ensure the received complimentary signals are with a differential amplitude of <1800 mVpp and a common-mode voltage of <2 V

### 10.2.3 Application Curves

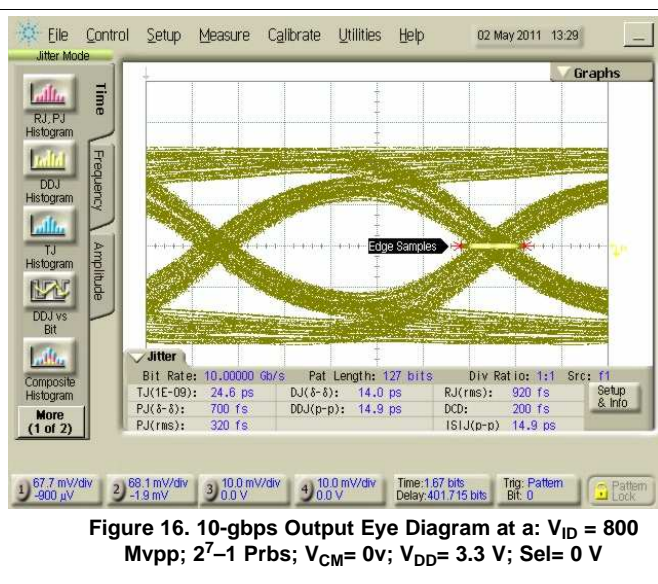
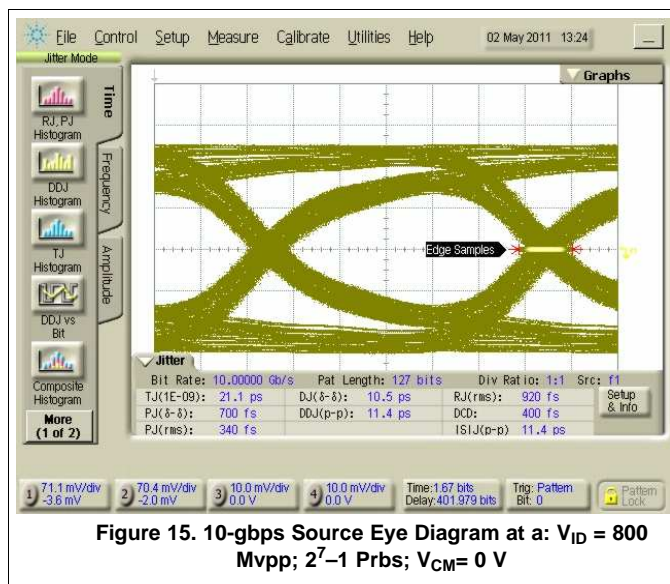

## 11 Power Supply Recommendations

The HD3SS3412 requires +3.3-V digital power sources. VDD 3.3 supply must have 0.1- $\mu$ F bypass capacitors to VSS (ground) in order for proper operation. The recommendation is one capacitor for each power terminal. Place the capacitor as close as possible to the terminal on the device and keep trace length to a minimum. Smaller value capacitors like 0.01- $\mu$ F are also recommended on the digital supply terminals.

## 12 Layout

### 12.1 Layout Guidelines

- Decoupling caps should be placed next to each power terminal on the HD3SS3412. Take care to minimize the stub length of the trace connecting the capacitor to the power pin.
- Avoid sharing vias between multiple decoupling caps
- Place vias as close as possible to the decoupling cap solder pad
- Widen VDD/GND planes to reduce effect of static and dynamic IR drop
- The VBUS traces/planes must be wide enough to carry maximum of 2-A current

### 12.2 Layout Example

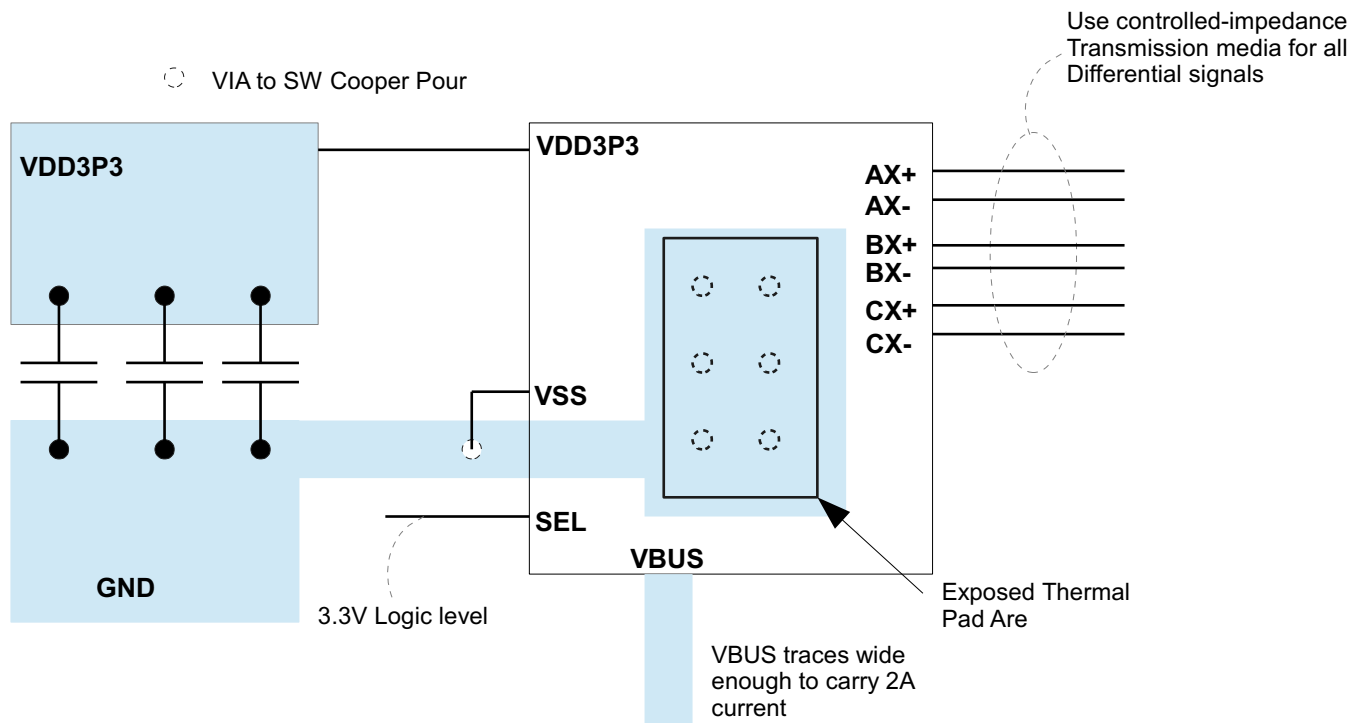

**Figure 17. Layout Example**

## 13 器件和文档支持

### 13.1 接收文档更新通知

要接收文档更新通知，请导航至 [TI.com.cn](http://TI.com.cn) 上的器件产品文件夹。单击右上角的 [通知我](#) 进行注册，即可每周接收产品信息更改摘要。有关更改的详细信息，请查看任何已修订文档中包含的修订历史记录。

### 13.2 社区资源

下列链接提供到 TI 社区资源的连接。链接的内容由各个分销商“按照原样”提供。这些内容并不构成 TI 技术规范，并且不一定反映 TI 的观点；请参阅 TI 的 [《使用条款》](#)。

**TI E2E™ 在线社区** [TI 的工程师对工程师 \(E2E\) 社区](#)。此社区的创建目的在于促进工程师之间的协作。在 [e2e.ti.com](http://e2e.ti.com) 中，您可以咨询问题、分享知识、拓展思路并与同行工程师一道帮助解决问题。

**设计支持** [TI 参考设计支持](#) 可帮助您快速查找有帮助的 E2E 论坛、设计支持工具以及技术支持的联系信息。

### 13.3 商标

E2E is a trademark of Texas Instruments.  
All other trademarks are the property of their respective owners.

### 13.4 静电放电警告



这些装置包含有限的内置 ESD 保护。存储或装卸时，应将导线一起截短或将装置放置于导电泡棉中，以防止 MOS 门极遭受静电损伤。

### 13.5 术语表



[SLYZ022](#) — *TI 术语表*。

这份术语表列出并解释术语、缩写和定义。

## 14 机械、封装和可订购信息

以下页面包含机械、封装和可订购信息。这些信息是指定器件的最新可用数据。数据如有变更，恕不另行通知，且不会对此文档进行修订。如需获取此产品说明书的浏览器版本，请查阅左侧的导航栏。

**PACKAGING INFORMATION**

Orderable Device	Status (1)	Package Type	Package Drawing	Pins	Package Qty	Eco Plan (2)	Lead finish/ Ball material (6)	MSL Peak Temp (3)	Op Temp (°C)	Device Marking (4/5)	Samples
HD3SS3412RUAR	ACTIVE	WQFN	RUA	42	3000	RoHS & Green	NIPDAU	Level-2-260C-1 YEAR	0 to 70	HD3SS3412	
HD3SS3412RUAT	ACTIVE	WQFN	RUA	42	250	RoHS & Green	NIPDAU	Level-2-260C-1 YEAR	0 to 70	XHD3SS3412 HD3SS3412	

(1) The marketing status values are defined as follows:

**ACTIVE:** Product device recommended for new designs.

**LIFEBUY:** TI has announced that the device will be discontinued, and a lifetime-buy period is in effect.

**NRND:** Not recommended for new designs. Device is in production to support existing customers, but TI does not recommend using this part in a new design.

**PREVIEW:** Device has been announced but is not in production. Samples may or may not be available.

**OBSOLETE:** TI has discontinued the production of the device.

(2) **RoHS:** TI defines "RoHS" to mean semiconductor products that are compliant with the current EU RoHS requirements for all 10 RoHS substances, including the requirement that RoHS substance do not exceed 0.1% by weight in homogeneous materials. Where designed to be soldered at high temperatures, "RoHS" products are suitable for use in specified lead-free processes. TI may reference these types of products as "Pb-Free".

**RoHS Exempt:** TI defines "RoHS Exempt" to mean products that contain lead but are compliant with EU RoHS pursuant to a specific EU RoHS exemption.

**Green:** TI defines "Green" to mean the content of Chlorine (Cl) and Bromine (Br) based flame retardants meet JS709B low halogen requirements of <=1000ppm threshold. Antimony trioxide based flame retardants must also meet the <=1000ppm threshold requirement.

(3) MSL, Peak Temp. - The Moisture Sensitivity Level rating according to the JEDEC industry standard classifications, and peak solder temperature.

(4) There may be additional marking, which relates to the logo, the lot trace code information, or the environmental category on the device.

(5) Multiple Device Markings will be inside parentheses. Only one Device Marking contained in parentheses and separated by a "-" will appear on a device. If a line is indented then it is a continuation of the previous line and the two combined represent the entire Device Marking for that device.

(6) Lead finish/Ball material - Orderable Devices may have multiple material finish options. Finish options are separated by a vertical ruled line. Lead finish/Ball material values may wrap to two lines if the finish value exceeds the maximum column width.

**Important Information and Disclaimer:**The information provided on this page represents TI's knowledge and belief as of the date that it is provided. TI bases its knowledge and belief on information provided by third parties, and makes no representation or warranty as to the accuracy of such information. Efforts are underway to better integrate information from third parties. TI has taken and continues to take reasonable steps to provide representative and accurate information but may not have conducted destructive testing or chemical analysis on incoming materials and chemicals. TI and TI suppliers consider certain information to be proprietary, and thus CAS numbers and other limited information may not be available for release.

In no event shall TI's liability arising out of such information exceed the total purchase price of the TI part(s) at issue in this document sold by TI to Customer on an annual basis.



## TAPE AND REEL INFORMATION



### QUADRANT ASSIGNMENTS FOR PIN 1 ORIENTATION IN TAPE



\*All dimensions are nominal

Device	Package Type	Package Drawing	Pins	SPQ	Reel Diameter (mm)	Reel Width W1 (mm)	A0 (mm)	B0 (mm)	K0 (mm)	P1 (mm)	W (mm)	Pin1 Quadrant
HD3SS3412RUAR	WQFN	RUA	42	3000	330.0	16.4	3.8	9.3	1.0	8.0	16.0	Q1
HD3SS3412RUAT	WQFN	RUA	42	250	180.0	16.4	3.8	9.3	1.0	8.0	16.0	Q1

**TAPE AND REEL BOX DIMENSIONS**

\*All dimensions are nominal

Device	Package Type	Package Drawing	Pins	SPQ	Length (mm)	Width (mm)	Height (mm)
HD3SS3412RUAR	WQFN	RUA	42	3000	367.0	367.0	38.0
HD3SS3412RUAT	WQFN	RUA	42	250	210.0	185.0	35.0

## GENERIC PACKAGE VIEW

**RUA 42**

**WQFN - 0.8 mm max height**

9 x 3.5, 0.5 mm pitch

PLASTIC QUAD FLATPACK - NO LEAD

This image is a representation of the package family, actual package may vary.  
Refer to the product data sheet for package details.

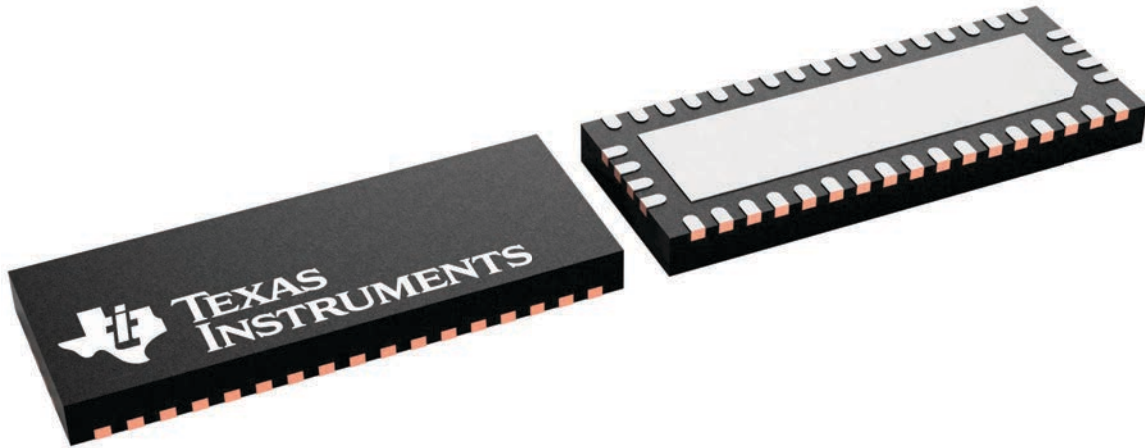

4226504/A

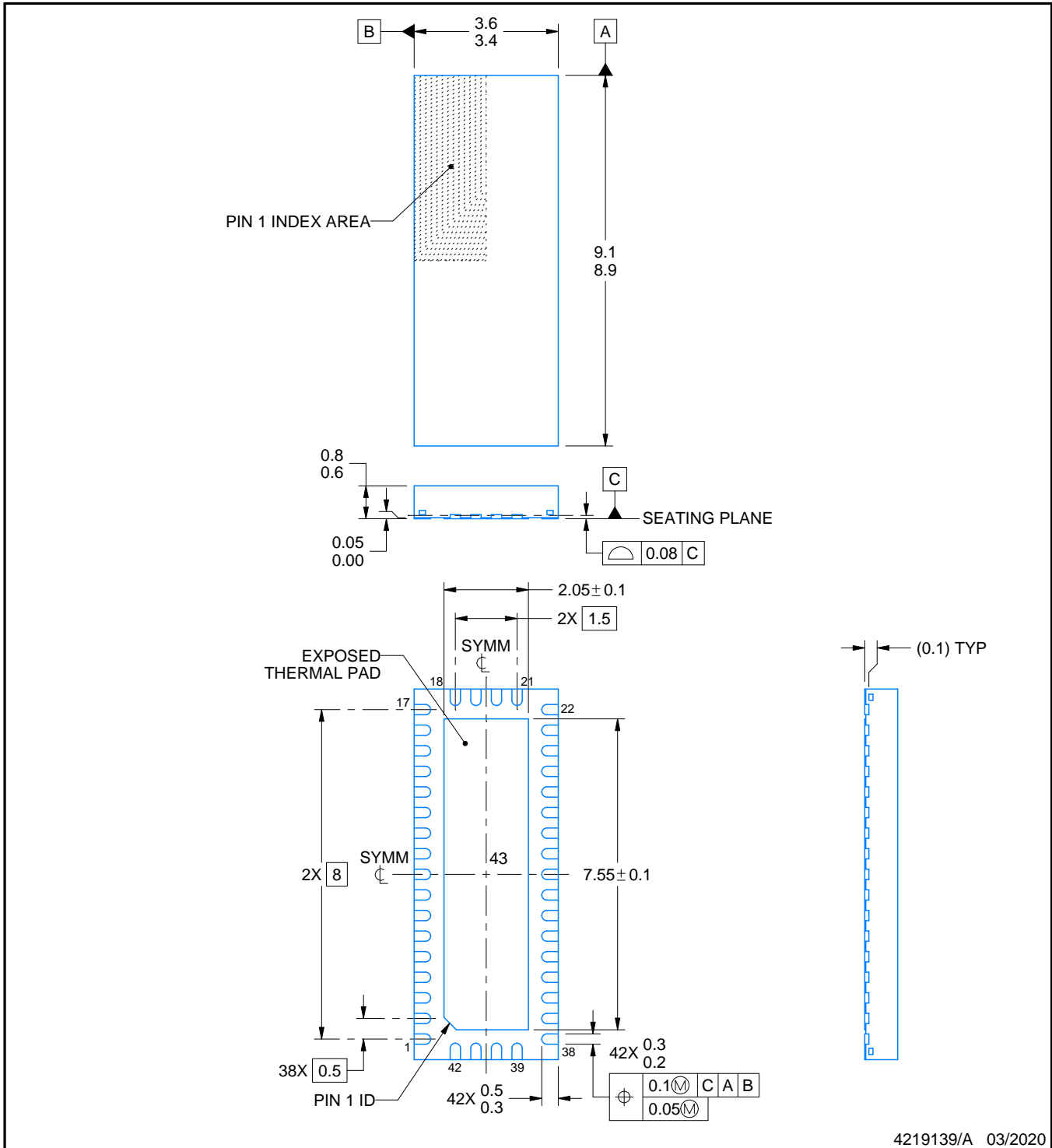
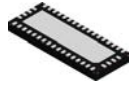

4219139/A 03/2020

NOTES:

1. All linear dimensions are in millimeters. Any dimensions in parenthesis are for reference only. Dimensioning and tolerancing per ASME Y14.5M.
2. This drawing is subject to change without notice.
3. The package thermal pad must be soldered to the printed circuit board for thermal and mechanical performance.



# EXAMPLE STENCIL DESIGN

RUA0042A

WQFN - 0.8 mm max height

PLASTIC QUAD FLATPACK - NO LEAD

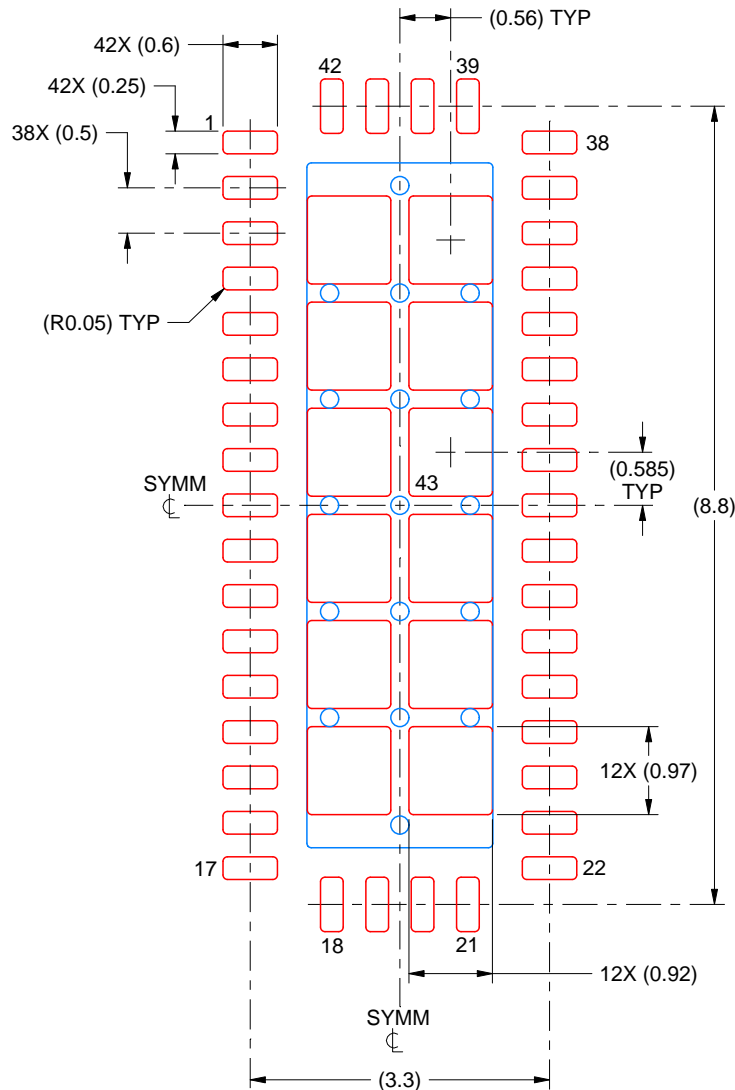

SOLDER PASTE EXAMPLE  
BASED ON 0.125 MM THICK STENCIL  
SCALE: 12X

EXPOSED PAD 43  
69% PRINTED SOLDER COVERAGE BY AREA UNDER PACKAGE

4219139/A 03/2020

NOTES: (continued)

6. Laser cutting apertures with trapezoidal walls and rounded corners may offer better paste release. IPC-7525 may have alternate design recommendations.

## 重要声明和免责声明

TI 提供技术和可靠性数据（包括数据表）、设计资源（包括参考设计）、应用或其他设计建议、网络工具、安全信息和其他资源，不保证没有瑕疵且不做任何明示或暗示的担保，包括但不限于对适销性、某特定用途方面的适用性或不侵犯任何第三方知识产权的暗示担保。

这些资源可供使用 TI 产品进行设计的熟练开发人员使用。您将自行承担以下全部责任：(1) 针对您的应用选择合适的 TI 产品，(2) 设计、验证并测试您的应用，(3) 确保您的应用满足相应标准以及任何其他安全、安保或其他要求。这些资源如有变更，恕不另行通知。TI 授权您仅可将这些资源用于研发本资源所述的 TI 产品的应用。严禁对这些资源进行其他复制或展示。您无权使用任何其他 TI 知识产权或任何第三方知识产权。您应全额赔偿因在这些资源的使用中对 TI 及其代表造成的任何索赔、损害、成本、损失和债务，TI 对此概不负责。

TI 提供的产品受 TI 的销售条款 (<https://www.ti.com.cn/zh-cn/legal/termsofsale.html>) 或 [ti.com.cn](https://www.ti.com.cn) 上其他适用条款/TI 产品随附的其他适用条款的约束。TI 提供这些资源并不会扩展或以其他方式更改 TI 针对 TI 产品发布的适用的担保或担保免责声明。

邮寄地址：上海市浦东新区世纪大道 1568 号中建大厦 32 楼，邮政编码：200122

Copyright © 2021 德州仪器半导体技术（上海）有限公司