

SN74LVC1G80 单路正缘触发 D 型触发器

1 特性

- 采用德州仪器 (TI) 的 NanoFree™ 封装
- 锁断性能超过 100mA, 符合 JESD 78 II 类规范的要求
- 静电放电 (ESD) 保护性能超过 JESD 22 规范的要求
 - 2000V 人体放电模型 (A114-A)
 - 200V 机器放电模式 (A115-A)
 - 1000V 组件充电模式 (C101)
- 支持 5V V_{CC} 运行
- 输入接受的电压达到高达 5.5V
- 支持向下转换到 V_{CC}
- 3.3V 时 t_{pd} 最大值为 4.2ns
- 低功耗, 10 μ A 最大 I_{CC}
- 电压为 3.3V 时, 输出驱动为 ± 24 mA
- I_{off} 支持部分断电模式和后驱动保护
- 锁断性能超过 100mA, 符合 JESD 78 II 类规范的要求

2 应用

- 测试和测量
- 企业交换
- 电信基础设施
- 个人电子产品
- 白色家电

3 说明

SN74LVC1G80 器件是一款单路正缘触发 D 型触发器, 专为 1.65V 到 5.5V V_{CC} 操作而设计。

当数据 (D) 输入处的数据满足设置时间要求时, 该数据将传输到时钟脉冲正向缘上的 \bar{Q} 输出。时钟触发出现在一个特定电压电平上, 并且不与时钟脉冲的上升时间直接相关。经过保持时间间隔后, 可以更改 D 输入处的数据而不影响输出处的电平。

NanoFree™ 封装技术是 IC 封装概念的一项重大突破, 它将裸片用作封装。

该器件完全适用于使用 I_{off} 的局部掉电应用。当器件断电时, I_{off} 电路将会禁用输出。这会抑制电流反流到器件中, 从而防止损坏器件。

器件信息(1)

| 器件型号 | 封装 | 封装尺寸 (标称值) |
|----------------|------------|-----------------|
| SN74LVC1G80DBV | SOT-23 (5) | 2.90mm × 1.60mm |
| SN74LVC1G80DCK | SC70 (5) | 2.00mm × 1.25mm |
| SN74LVC1G80YZP | DSBGA (5) | 1.41mm × 0.91mm |

(1) 如需了解所有可用封装, 请参阅数据表末尾的可订购产品附录。

逻辑图 (正逻辑)

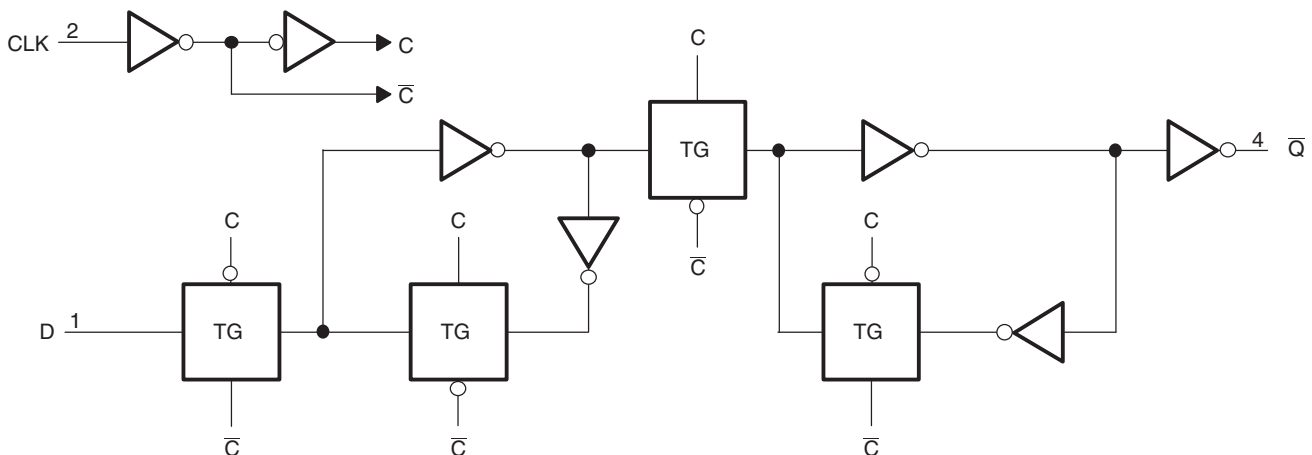

(1) TG - 传输门

Copyright © 2017, Texas Instruments Incorporated



目录

| | | | | | |
|------|---|---|------|---|----|
| 1 | 特性 | 1 | 7 | Parameter Measurement Information | 10 |
| 2 | 应用 | 1 | 8 | Detailed Description | 12 |
| 3 | 说明 | 1 | 8.1 | Overview | 12 |
| 4 | 修订历史记录 | 2 | 8.2 | Functional Block Diagram | 12 |
| 5 | Pin Configuration and Functions | 3 | 8.3 | Feature Description | 12 |
| 6 | Specifications | 4 | 8.4 | Device Functional Modes | 13 |
| 6.1 | Absolute Maximum Ratings | 4 | 9 | Application and Implementation | 14 |
| 6.2 | ESD Ratings | 4 | 9.1 | Application Information | 14 |
| 6.3 | Recommended Operating Conditions | 5 | 9.2 | Typical Application | 14 |
| 6.4 | Thermal Information | 5 | 10 | Power Supply Recommendations | 16 |
| 6.5 | Electrical Characteristics | 6 | 11 | Layout | 16 |
| 6.6 | Timing Requirements: $T_A = -40^{\circ}\text{C}$ to $+85^{\circ}\text{C}$ | 6 | 11.1 | Layout Guidelines | 16 |
| 6.7 | Timing Requirements: $T_A = -40^{\circ}\text{C}$ to $+125^{\circ}\text{C}$ | 7 | 11.2 | Layout Example | 16 |
| 6.8 | Switching Characteristics: $T_A = -40^{\circ}\text{C}$ to $+85^{\circ}\text{C}$, $C_L = 15\text{ pF}$ | 7 | 12 | 器件和文档支持 | 17 |
| 6.9 | Switching Characteristics: $T_A = -40^{\circ}\text{C}$ to $+85^{\circ}\text{C}$, $C_L = 30\text{ pF}$ or 50 pF | 7 | 12.1 | 文档支持 | 17 |
| 6.10 | Switching Characteristics: $T_A = -40^{\circ}\text{C}$ to $+125^{\circ}\text{C}$, $C_L = 30\text{ pF}$ or 50 pF | 8 | 12.2 | 接收文档更新通知 | 17 |
| 6.11 | Operating Characteristics | 8 | 12.3 | 社区资源 | 17 |
| 6.12 | Typical Characteristics | 9 | 12.4 | 商标 | 17 |
| | | | 12.5 | 静电放电警告 | 17 |
| | | | 12.6 | Glossary | 17 |
| | | | 13 | 机械、封装和可订购信息 | 17 |

4 修订历史记录

注：之前版本的页码可能与当前版本有所不同。

| Changes from Revision R (December 2013) to Revision S | Page |
|---|------|
| • 添加了应用部分、器件信息表、ESD 额定值表、热性能信息表、典型特性部分、特性说明部分、器件功能模式、应用和实施部分、电源相关建议部分、布局部分、器件和文档支持部分以及机械、封装和可订购信息部分。 | 1 |
| • Added max junction temperature to the <i>Recommended Operating Conditions</i> table | 5 |
| • Added operating free-air temperature for YZP package to the <i>Recommended Operating Conditions</i> table | 5 |
| • Changed $R_{\theta JA}$ value for DBV package from: $206^{\circ}\text{C}/\text{W}$ to: $243.4^{\circ}\text{C}/\text{W}$ | 5 |
| • Changed $R_{\theta JA}$ value for DCK package from: $252^{\circ}\text{C}/\text{W}$ to: $278.9^{\circ}\text{C}/\text{W}$ | 5 |
| • Changed $R_{\theta JA}$ value for YZP package from: $132^{\circ}\text{C}/\text{W}$ to: $136.9^{\circ}\text{C}/\text{W}$ | 5 |

| Changes from Revision Q (January 2007) to Revision R | Page |
|--|------|
| • 将文档更新至新的 TI 数据表。 | 1 |
| • 删除了订购信息表。 | 1 |
| • 更新了 I_{off} (特性部分)。 | 1 |
| • Updated operating temperature range. | 4 |
| • 添加了 ESD 警告 | 17 |

5 Pin Configuration and Functions

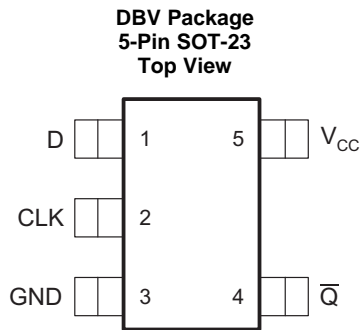
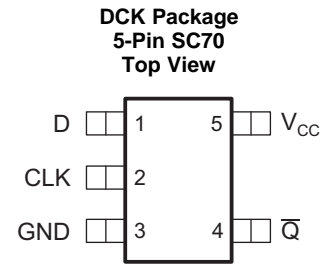
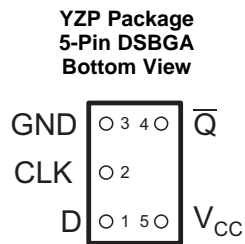

Pin Functions⁽¹⁾

| PIN | | I/O | DESCRIPTION |
|-----|-----------------|-----|-------------------------------------|
| NO. | NAME | | |
| 1 | D | I | Data input |
| 2 | CLK | I | Positive-Edge-Triggered Clock input |
| 3 | GND | — | Ground pin |
| 4 | \bar{Q} | O | Inverted output |
| 5 | V _{CC} | — | Positive Supply |

(1) See [机械、封装和可订购信息](#) for dimensions

6 Specifications

6.1 Absolute Maximum Ratings

 over operating free-air temperature range (unless otherwise noted)⁽¹⁾

| | | MIN | MAX | UNIT |
|-----------|---|-----------|----------------|------|
| V_{CC} | Supply voltage | –0.5 | 6.5 | V |
| V_I | Input voltage ⁽²⁾ | –0.5 | 6.5 | V |
| V_O | Voltage applied to any output in the high-impedance or power-off state ⁽²⁾ | –0.5 | 6.5 | V |
| V_O | Voltage applied to any output in the high or low state ⁽²⁾⁽³⁾ | –0.5 | $V_{CC} + 0.5$ | V |
| I_{IK} | Input clamp current | $V_I < 0$ | –50 | mA |
| I_{OK} | Output clamp current | $V_O < 0$ | –50 | mA |
| I_O | Continuous output current | | ±50 | mA |
| | Continuous current through V_{CC} or GND | | ±100 | mA |
| T_J | Junction temperature | | 150 | °C |
| T_{stg} | Storage temperature | –65 | 150 | °C |

- (1) Stresses beyond those listed under *Absolute Maximum Ratings* may cause permanent damage to the device. These are stress ratings only, and functional operation of the device at these or any other conditions beyond those indicated under *Recommended Operating Conditions* is not implied. Exposure to absolute-maximum-rated conditions for extended periods may affect device reliability.
- (2) The input negative-voltage and output voltage ratings may be exceeded if the input and output clamp-current ratings are observed.
- (3) The value of V_{CC} is provided in *Recommended Operating Conditions*.

6.2 ESD Ratings

| | | VALUE | UNIT |
|-------------|-------------------------|--|-------|
| $V_{(ESD)}$ | Electrostatic discharge | Human-body model (HBM), per ANSI/ESDA/JEDEC JS-001 ⁽¹⁾ | ±2000 |
| | | Charged-device model (CDM), per JEDEC specification JESD22-C101 ⁽²⁾ | ±1000 |
| | | Machine model (MM) | ±200 |

- (1) JEDEC document JEP155 states that 500-V HBM allows safe manufacturing with a standard ESD control process.
- (2) JEDEC document JEP157 states that 250-V CDM allows safe manufacturing with a standard ESD control process.

6.3 Recommended Operating Conditions

 over operating free-air temperature range (unless otherwise noted)⁽¹⁾

| | | | MIN | MAX | UNIT |
|-----------------|------------------------------------|---|------------------------|------------------------|------|
| V _{CC} | Supply voltage | Operating | 1.65 | 5.5 | V |
| | | Data retention only | 1.5 | | |
| V _{IH} | High-level input voltage | V _{CC} = 1.65 V to 1.95 V | 0.65 × V _{CC} | | V |
| | | V _{CC} = 2.3 V to 2.7 V | 1.7 | | |
| | | V _{CC} = 3 V to 3.6 V | 2 | | |
| | | V _{CC} = 4.5 V to 5.5 V | 0.7 × V _{CC} | | |
| V _{IL} | Low-level input voltage | V _{CC} = 1.65 V to 1.95 V | | 0.35 × V _{CC} | V |
| | | V _{CC} = 2.3 V to 2.7 V | | 0.7 | |
| | | V _{CC} = 3 V to 3.6 V | | 0.8 | |
| | | V _{CC} = 4.5 V to 5.5 V | | 0.3 × V _{CC} | |
| V _I | Input voltage | | 0 | 5.5 | V |
| V _O | Output voltage | | 0 | V _{CC} | V |
| I _{OH} | High-level output current | V _{CC} = 1.65 V | | –4 | mA |
| | | V _{CC} = 2.3 V | | –8 | |
| | | V _{CC} = 3 V | | –16 | |
| | | V _{CC} = 4.5 V | | –24 | |
| I _{OL} | Low-level output current | V _{CC} = 1.65 V | | 4 | mA |
| | | V _{CC} = 2.3 V | | 8 | |
| | | V _{CC} = 3 V | | 16 | |
| | | V _{CC} = 4.5 V | | 24 | |
| Δt/Δv | Input transition rise or fall rate | V _{CC} = 1.8 V ± 0.15 V, 2.5 V ± 0.2 V | | 20 | ns/V |
| | | V _{CC} = 3.3 V ± 0.3 V | | 10 | |
| | | V _{CC} = 5 V ± 0.5 V | | 5 | |
| T _J | Junction temperature | | | 150 | °C |
| T _A | Operating free-air temperature | DBV and DCK packages | –40 | 125 | °C |
| | | YZP package | –40 | 85 | |

(1) All unused inputs of the device must be held at V_{CC} or GND to ensure proper device operation. See the TI application report, [Implications of Slow or Floating CMOS Inputs](#) (SCBA004).

6.4 Thermal Information

| THERMAL METRIC ⁽¹⁾ | SN74LVC1G80 | | | UNIT | |
|-------------------------------|--|------------|-------------|-------|------|
| | DBV (SOT-23) | DCK (SC70) | YZP (DSBGA) | | |
| | 5 PINS | 5 PINS | 5 PINS | | |
| R _{θJA} | Junction-to-ambient thermal resistance | 243.4 | 278.9 | 136.9 | °C/W |
| R _{θJC(top)} | Junction-to-case (top) thermal resistance | 179 | 121.3 | 1.3 | °C/W |
| R _{θJB} | Junction-to-board thermal resistance | 77.6 | 65.6 | 32.6 | °C/W |
| ψ _{JT} | Junction-to-top characterization parameter | 58.4 | 7.5 | 6.3 | °C/W |
| ψ _{JB} | Junction-to-board characterization parameter | 77 | 64.9 | 32.6 | °C/W |

(1) For more information about traditional and new thermal metrics, see the [Semiconductor and IC Package Thermal Metrics](#) application report.

6.5 Electrical Characteristics

over recommended operating free-air temperature range (unless otherwise noted)

| PARAMETER | TEST CONDITIONS | V _{CC} | MIN | TYP ⁽¹⁾ | MAX | UNIT | |
|------------------|---------------------------|---|--------------------------------|--------------------|-------|------|----|
| V _{OH} | I _{OH} = -100 μA | 1.65 V to 5.5 V | V _{CC} - 0.1 | | | V | |
| | I _{OH} = -4 mA | 1.65 V | 1.2 | | | | |
| | I _{OH} = -8 mA | 2.3 V | 1.9 | | | | |
| | I _{OH} = -16 mA | 3 V | 2.4 | | | | |
| | I _{OH} = -24 mA | | 2.3 | | | | |
| | I _{OH} = -32 mA | 4.5 V | 3.8 | | | | |
| V _{OL} | I _{OL} = 100 μA | 1.65 V to 5.5 V | 0.1 | | | V | |
| | I _{OL} = 4 mA | 1.65 V | 0.45 | | | | |
| | I _{OL} = 8 mA | 2.3 V | 0.3 | | | | |
| | I _{OL} = 16 mA | 3 V | 0.4 | | | | |
| | I _{OL} = 24 mA | | 0.55 | | | | |
| | I _{OL} = 32 mA | 4.5 V | 0.55 | | | | |
| I _I | CLK or D inputs | V _I = 5.5 V or GND | 0 to 5.5 V | | ±10 | μA | |
| I _{off} | | V _I or V _O = 5.5 V | 0 | | ±10 | μA | |
| I _{CC} | | V _I = 5.5 V or GND, I _O = 0 | 1.65 V to 5.5 V | | 10 | μA | |
| ΔI _{CC} | | One input at V _{CC} - 0.6 V, Other inputs at V _{CC} or GND | 3 V to 5.5 V | | 500 | μA | |
| C _i | | V _I = V _{CC} or GND | T _A = -40°C to 85°C | | 3.3 V | 3.5 | pF |

 (1) All typical values are at V_{CC} = 3.3 V, T_A = 25°C.

6.6 Timing Requirements: T_A = -40°C to +85°C

 over recommended operating free-air temperature range, T_A = -40°C to +85°C (unless otherwise noted) (see [Figure 3](#))

| | | V _{CC} | MIN | MAX | UNIT |
|--------------------|---------------------------------|----------------------------------|-----|-----|------|
| f _{clock} | Clock frequency | V _{CC} = 1.8 V ± 0.15 V | 160 | | MHz |
| | | V _{CC} = 2.5 V ± 0.2 V | | | |
| | | V _{CC} = 3.3 V ± 0.3 V | | | |
| | | V _{CC} = 5.5 V ± 0.5 V | | | |
| t _w | Pulse duration, CLK high or low | V _{CC} = 1.8 V ± 0.15 V | 2.5 | | ns |
| | | V _{CC} = 2.5 V ± 0.2 V | | | |
| | | V _{CC} = 3.3 V ± 0.3 V | | | |
| | | V _{CC} = 5.5 V ± 0.5 V | | | |
| t _{su} | Data high | V _{CC} = 1.8 V ± 0.15 V | 2.3 | | ns |
| | | V _{CC} = 2.5 V ± 0.2 V | | | |
| | | V _{CC} = 3.3 V ± 0.3 V | | | |
| | | V _{CC} = 5.5 V ± 0.5 V | | | |
| | Data low | V _{CC} = 1.8 V ± 0.15 V | 2.5 | | |
| | | V _{CC} = 2.5 V ± 0.2 V | | | |
| | | V _{CC} = 3.3 V ± 0.3 V | | | |
| | | V _{CC} = 5.5 V ± 0.5 V | | | |
| t _h | Hold time, data after CLK↑ | V _{CC} = 1.8 V ± 0.15 V | 0 | | ns |
| | | V _{CC} = 2.5 V ± 0.2 V | | | |
| | | V _{CC} = 3.3 V ± 0.3 V | | | |
| | | V _{CC} = 5.5 V ± 0.5 V | | | |

6.7 Timing Requirements: $T_A = -40^\circ\text{C}$ to $+125^\circ\text{C}$

 over recommended operating free-air temperature range, $T_A = -40^\circ\text{C}$ to $+125^\circ\text{C}$ (unless otherwise noted) (see [Figure 3](#))

| | | V_{CC} | MIN | MAX | UNIT |
|--------------------|--------------------------------------|---|-----|-----|------|
| f_{clock} | Clock frequency | $V_{CC} = 1.8\text{ V} \pm 0.15\text{ V}$ | 160 | 160 | MHz |
| | | $V_{CC} = 2.5\text{ V} \pm 0.2\text{ V}$ | | | |
| | | $V_{CC} = 3.3\text{ V} \pm 0.3\text{ V}$ | | | |
| | | $V_{CC} = 5.5\text{ V} \pm 0.5\text{ V}$ | | | |
| t_w | Pulse duration, CLK high or low | $V_{CC} = 1.8\text{ V} \pm 0.15\text{ V}$ | 2.5 | | ns |
| | | $V_{CC} = 2.5\text{ V} \pm 0.2\text{ V}$ | | | |
| | | $V_{CC} = 3.3\text{ V} \pm 0.3\text{ V}$ | | | |
| | | $V_{CC} = 5.5\text{ V} \pm 0.5\text{ V}$ | | | |
| t_{su} | Data high | $V_{CC} = 1.8\text{ V} \pm 0.15\text{ V}$ | 2.3 | | ns |
| | | $V_{CC} = 2.5\text{ V} \pm 0.2\text{ V}$ | 1.5 | | |
| | | $V_{CC} = 3.3\text{ V} \pm 0.3\text{ V}$ | 1.3 | | |
| | | $V_{CC} = 5.5\text{ V} \pm 0.5\text{ V}$ | 1.1 | | |
| | Data low | $V_{CC} = 1.8\text{ V} \pm 0.15\text{ V}$ | 2.5 | | |
| | | $V_{CC} = 2.5\text{ V} \pm 0.2\text{ V}$ | 1.5 | | |
| | | $V_{CC} = 3.3\text{ V} \pm 0.3\text{ V}$ | 1.3 | | |
| | | $V_{CC} = 5.5\text{ V} \pm 0.5\text{ V}$ | 1.1 | | |
| t_h | Hold time, data after CLK \uparrow | $V_{CC} = 1.8\text{ V} \pm 0.15\text{ V}$ | 0 | | ns |
| | | $V_{CC} = 2.5\text{ V} \pm 0.2\text{ V}$ | 0.2 | | |
| | | $V_{CC} = 3.3\text{ V} \pm 0.3\text{ V}$ | 0.9 | | |
| | | $V_{CC} = 5.5\text{ V} \pm 0.5\text{ V}$ | 0.4 | | |

6.8 Switching Characteristics: $T_A = -40^\circ\text{C}$ to $+85^\circ\text{C}$, $C_L = 15\text{ pF}$

 over recommended operating free-air temperature range, $T_A = -40^\circ\text{C}$ to $+85^\circ\text{C}$, $C_L = 15\text{ pF}$ (unless otherwise noted) (see [Figure 3](#))

| PARAMETER | FROM (INPUT) | TO (OUTPUT) | V_{CC} | MIN | MAX | UNIT |
|------------------|--------------|-------------|---|-----|-----|------|
| f_{max} | | | $V_{CC} = 1.8\text{ V} \pm 0.15\text{ V}$ | 160 | | MHz |
| | | | $V_{CC} = 2.5\text{ V} \pm 0.2\text{ V}$ | | | |
| | | | $V_{CC} = 3.3\text{ V} \pm 0.3\text{ V}$ | | | |
| | | | $V_{CC} = 5\text{ V} \pm 0.5\text{ V}$ | | | |
| t_{pd} | CLK | \bar{Q} | $V_{CC} = 1.8\text{ V} \pm 0.15\text{ V}$ | 3 | 9.1 | ns |
| | | | $V_{CC} = 2.5\text{ V} \pm 0.2\text{ V}$ | 1.5 | 6 | |
| | | | $V_{CC} = 3.3\text{ V} \pm 0.3\text{ V}$ | 1.3 | 4.2 | |
| | | | $V_{CC} = 5\text{ V} \pm 0.5\text{ V}$ | 1.1 | 3.8 | |

6.9 Switching Characteristics: $T_A = -40^\circ\text{C}$ to $+85^\circ\text{C}$, $C_L = 30\text{ pF}$ or 50 pF

 over recommended operating free-air temperature range, $T_A = -40^\circ\text{C}$ to $+85^\circ\text{C}$, $C_L = 30\text{ pF}$ or 50 pF (unless otherwise noted) (see [Figure 4](#))

| PARAMETER | FROM (INPUT) | TO (OUTPUT) | V_{CC} | MIN | MAX | UNIT |
|------------------|--------------|-------------|---|-----|-----|------|
| f_{max} | | | $V_{CC} = 1.8\text{ V} \pm 0.15\text{ V}$ | 160 | | MHz |
| | | | $V_{CC} = 2.5\text{ V} \pm 0.2\text{ V}$ | | | |
| | | | $V_{CC} = 3.3\text{ V} \pm 0.3\text{ V}$ | | | |
| | | | $V_{CC} = 5\text{ V} \pm 0.5\text{ V}$ | | | |
| t_{pd} | CLK | \bar{Q} | $V_{CC} = 1.8\text{ V} \pm 0.15\text{ V}$ | 4.4 | 9.9 | ns |
| | | | $V_{CC} = 2.5\text{ V} \pm 0.2\text{ V}$ | 2.3 | 7 | |
| | | | $V_{CC} = 3.3\text{ V} \pm 0.3\text{ V}$ | 2 | 5.2 | |
| | | | $V_{CC} = 5\text{ V} \pm 0.5\text{ V}$ | 1.3 | 4.5 | |

SN74LVC1G80

ZHCSH06S – APRIL 1999 – REVISED NOVEMBER 2016

www.ti.com.cn
6.10 Switching Characteristics: $T_A = -40^\circ\text{C}$ to $+125^\circ\text{C}$, $C_L = 30\text{ pF}$ or 50 pF

 over recommended operating free-air temperature range, $T_A = -40^\circ\text{C}$ to $+125^\circ\text{C}$, $C_L = 30\text{ pF}$ or 50 pF (unless otherwise noted) (see [Figure 4](#))

| PARAMETER | FROM (INPUT) | TO (OUTPUT) | V_{CC} | MIN | MAX | UNIT |
|-----------|--------------|-------------|---|-----|------|------|
| f_{max} | | | $V_{CC} = 1.8\text{ V} \pm 0.15\text{ V}$ | 160 | | MHz |
| | | | $V_{CC} = 2.5\text{ V} \pm 0.2\text{ V}$ | | | |
| | | | $V_{CC} = 3.3\text{ V} \pm 0.3\text{ V}$ | | | |
| | | | $V_{CC} = 5\text{ V} \pm 0.5\text{ V}$ | | | |
| t_{pd} | CLK | \bar{Q} | $V_{CC} = 1.8\text{ V} \pm 0.15\text{ V}$ | 4.4 | 12.5 | ns |
| | | | $V_{CC} = 2.5\text{ V} \pm 0.2\text{ V}$ | 2.3 | 8.5 | |
| | | | $V_{CC} = 3.3\text{ V} \pm 0.3\text{ V}$ | 2 | 6 | |
| | | | $V_{CC} = 5\text{ V} \pm 0.5\text{ V}$ | 1.3 | 5.5 | |

6.11 Operating Characteristics
 $T_A = 25^\circ\text{C}$

| PARAMETER | TEST CONDITIONS | V_{CC} | TYP | UNIT | |
|-----------|-------------------------------|---------------------|-------------------------|------|----|
| C_{pd} | Power dissipation capacitance | $f = 10\text{ MHz}$ | $V_{CC} = 1.8\text{ V}$ | 24 | pF |
| | | | $V_{CC} = 2.5\text{ V}$ | 24 | |
| | | | $V_{CC} = 3.3\text{ V}$ | 25 | |
| | | | $V_{CC} = 5\text{ V}$ | 27 | |

6.12 Typical Characteristics

This plot shows the different I_{CC} values for various voltages on the data input (D). Voltage sweep on the input is from 0 V to 6.5 V.

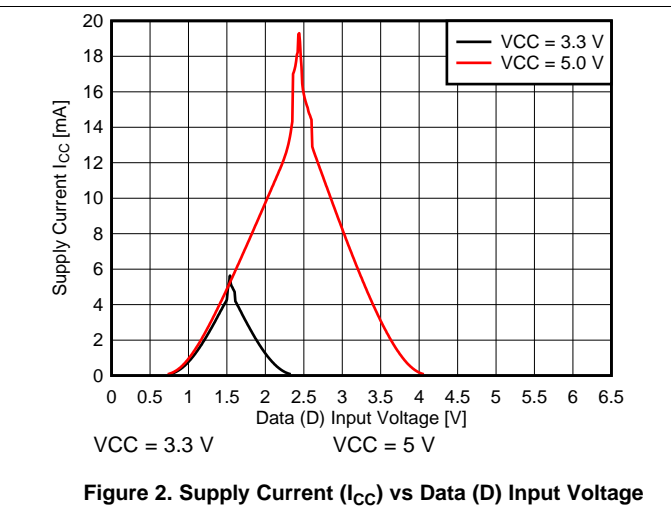
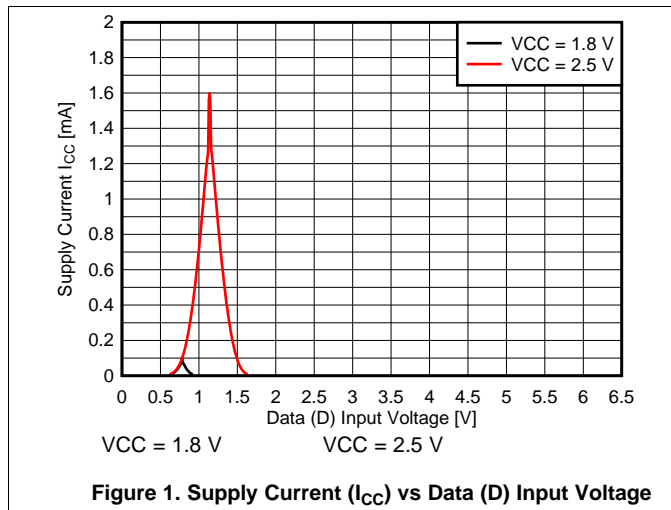

7 Parameter Measurement Information

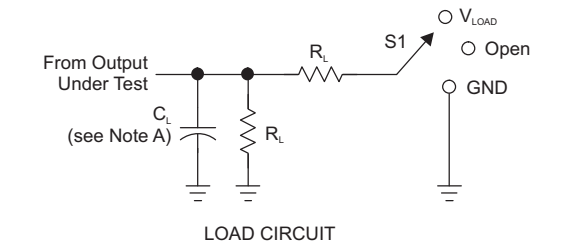

| TEST | S1 |
|-------------------|------------|
| t_{PLH}/t_{PHL} | Open |
| t_{PLZ}/t_{PZL} | V_{LOAD} |
| t_{PHZ}/t_{PZH} | GND |

| V_{CC} | INPUTS | | V_M | V_{LOAD} | C_L | R_L | V_D |
|----------------------------------|----------|---------|------------|-------------------|-------|-------|--------|
| | V_I | t/t | | | | | |
| $1.8\text{ V} \pm 0.15\text{ V}$ | V_{CC} | £2 ns | $V_{CC}/2$ | $2 \times V_{CC}$ | 15 pF | 1 MW | 0.15 V |
| $2.5\text{ V} \pm 0.2\text{ V}$ | V_{CC} | £2 ns | $V_{CC}/2$ | $2 \times V_{CC}$ | 15 pF | 1 MW | 0.15 V |
| $3.3\text{ V} \pm 0.3\text{ V}$ | 3 V | £2.5 ns | 1.5 V | 6 V | 15 pF | 1 MW | 0.3 V |
| $5\text{ V} \pm 0.5\text{ V}$ | V_{CC} | £2.5 ns | $V_{CC}/2$ | $2 \times V_{CC}$ | 15 pF | 1 MW | 0.3 V |

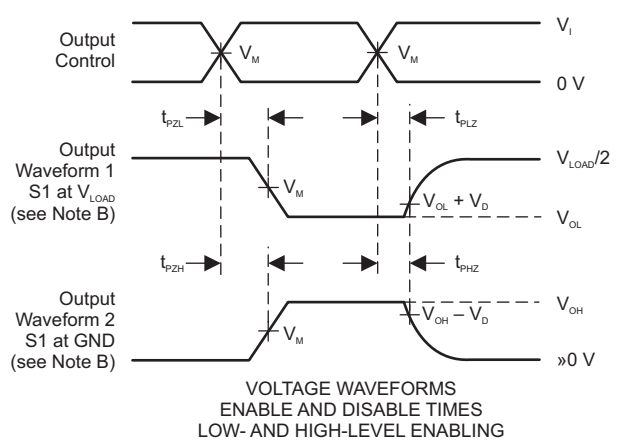
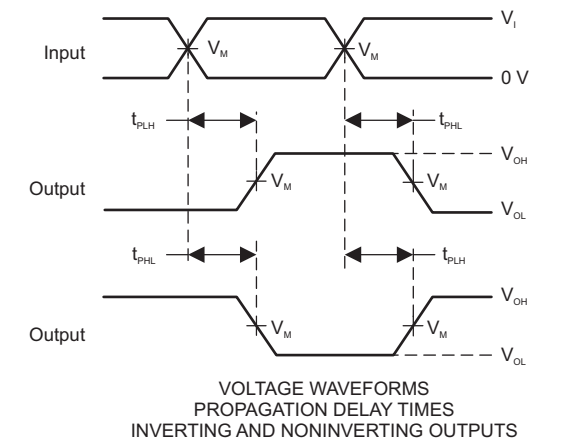
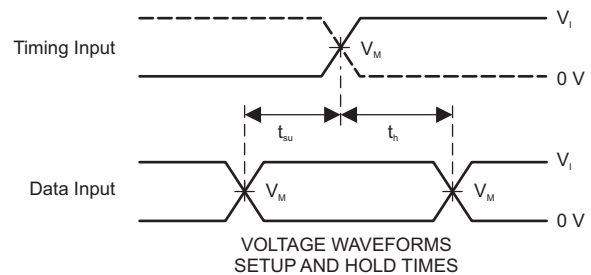
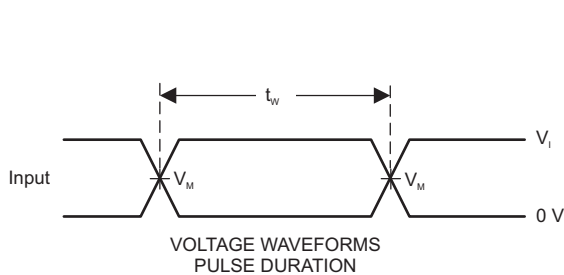

- NOTES:
- A. C_L includes probe and jig capacitance.
 - B. Waveform 1 is for an output with internal conditions such that the output is low, except when disabled by the output control. Waveform 2 is for an output with internal conditions such that the output is high, except when disabled by the output control.
 - C. All input pulses are supplied by generators having the following characteristics: PRR £ 10 MHz, $Z_o = 50\ \Omega$.
 - D. The outputs are measured one at a time, with one transition per measurement.
 - E. t_{PLZ} and t_{PHZ} are the same as t_{dis} .
 - F. t_{PZL} and t_{PZH} are the same as t_{en} .
 - G. t_{PLH} and t_{PHL} are the same as t_{pd} .
 - H. All parameters and waveforms are not applicable to all devices.

Figure 3. Load Circuit and Voltage Waveforms

Parameter Measurement Information (continued)

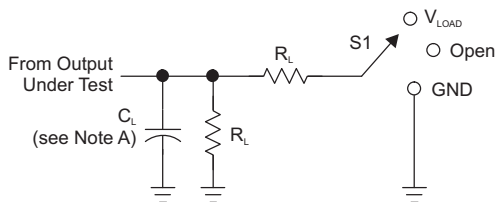

LOAD CIRCUIT

| TEST | S1 |
|-------------------|------------|
| t_{PLH}/t_{PHL} | Open |
| t_{PLZ}/t_{PZL} | V_{LOAD} |
| t_{PHZ}/t_{PZH} | GND |

| V_{CC} | INPUTS | | V_M | V_{LOAD} | C_L | R_L | V_D |
|--------------------|----------|---------|------------|-------------------|-------|-------|--------|
| | V_I | t/t_i | | | | | |
| $1.8 V \pm 0.15 V$ | V_{CC} | £2 ns | $V_{CC}/2$ | $2 \times V_{CC}$ | 30 pF | 1 kW | 0.15 V |
| $2.5 V \pm 0.2 V$ | V_{CC} | £2 ns | $V_{CC}/2$ | $2 \times V_{CC}$ | 30 pF | 500 W | 0.15 V |
| $3.3 V \pm 0.3 V$ | 3 V | £2.5 ns | 1.5 V | 6 V | 50 pF | 500 W | 0.3 V |
| $5 V \pm 0.5 V$ | V_{CC} | £2.5 ns | $V_{CC}/2$ | $2 \times V_{CC}$ | 50 pF | 500 W | 0.3 V |

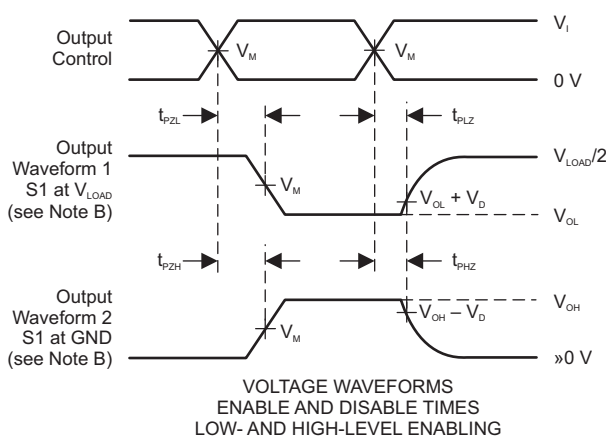
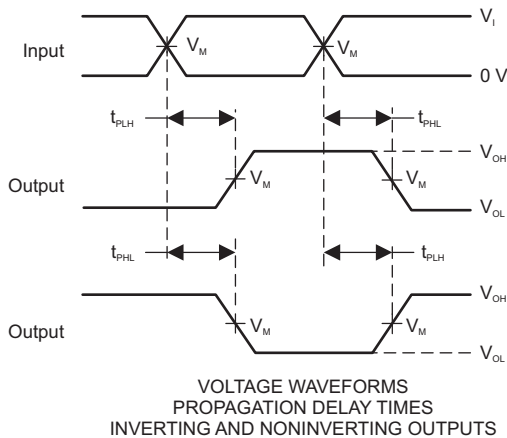
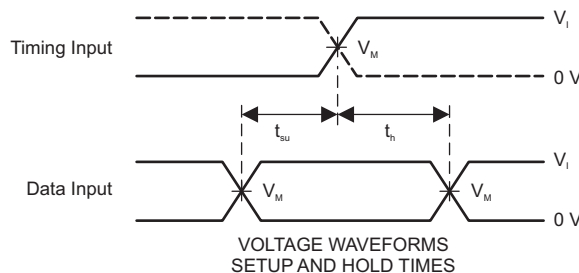
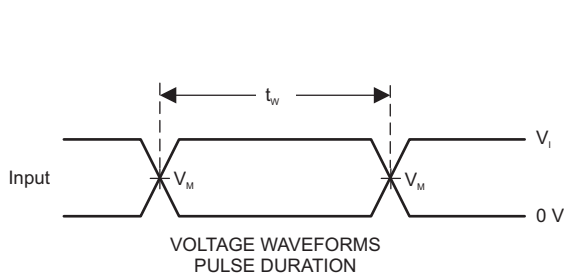

- NOTES:
- A. C_L includes probe and jig capacitance.
 - B. Waveform 1 is for an output with internal conditions such that the output is low, except when disabled by the output control. Waveform 2 is for an output with internal conditions such that the output is high, except when disabled by the output control.
 - C. All input pulses are supplied by generators having the following characteristics: PRR £ 10 MHz, $Z_o = 50 \Omega$.
 - D. The outputs are measured one at a time, with one transition per measurement.
 - E. t_{PLZ} and t_{PHZ} are the same as t_{dis} .
 - F. t_{PZL} and t_{PZH} are the same as t_{en} .
 - G. t_{PLH} and t_{PHL} are the same as t_{pd} .
 - H. All parameters and waveforms are not applicable to all devices.

Figure 4. Load Circuit and Voltage Waveforms

8 Detailed Description

8.1 Overview

The SN74LVC1G80 is a single positive-edge-trigger D-type flip-flop. Data at the input (D) is transferred to the output (\bar{Q}) on the positive-going edge of the clock pulse when the setup time requirement is met. Because the clock triggering occurs at a voltage level, it is not directly related to the rise time of the clock pulse. This allows for data at the input to be changed without affecting the level at the output, following the hold-time interval.

8.2 Functional Block Diagram

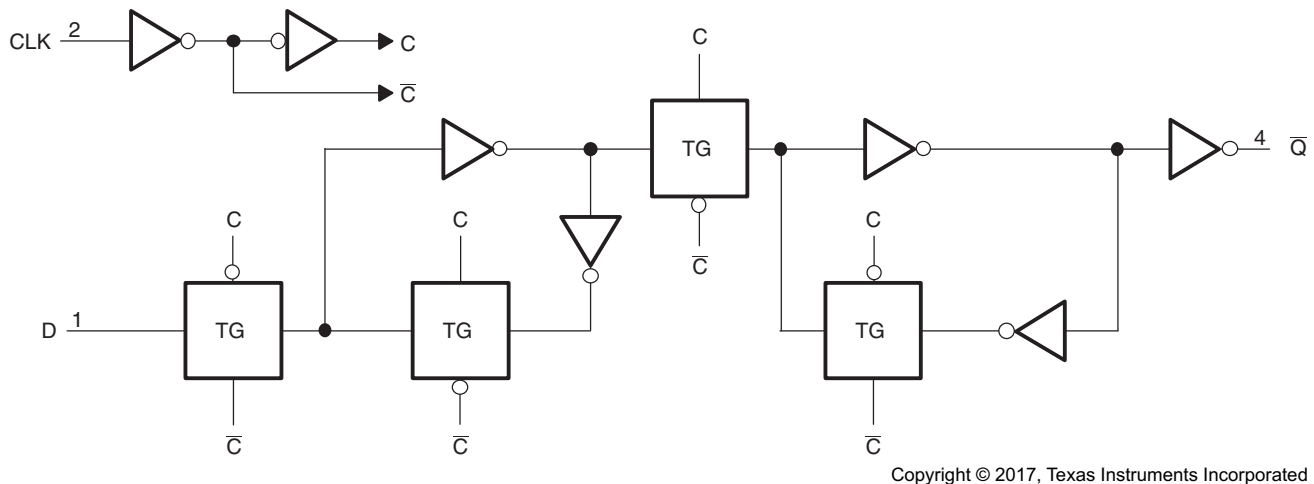

Figure 5. Logic Diagram (Positive Logic)

8.3 Feature Description

8.3.1 Balanced High-Drive CMOS Push-Pull Outputs

A balanced output allows the device to sink and source similar currents. The high drive capability of this device creates fast edges into light loads so routing and load conditions should be considered to prevent ringing. Additionally, the outputs of this device are capable of driving larger currents than the device can sustain without being damaged. It is important for the power output of the device to be limited to avoid thermal runaway and damage due to over-current. The electrical and thermal limits defined in the [Absolute Maximum Ratings](#) must be followed at all times.

8.3.2 Standard CMOS Inputs

Standard CMOS inputs are high impedance and are typically modeled as a resistor in parallel with the input capacitance given in the [Electrical Characteristics](#). The worst case resistance is calculated with the maximum input voltage, given in the [Recommended Operating Conditions](#), and the maximum input leakage current, given in the [Electrical Characteristics](#), using ohm's law ($R = V \div I$).

Signals applied to the inputs need to have fast edge rates, as defined by $\Delta t/\Delta v$ in [Recommended Operating Conditions](#) to avoid excessive currents and oscillations. If tolerance to a slow or noisy input signal is required, a device with a Schmitt-trigger input should be utilized to condition the input signal prior to the standard CMOS input.

Feature Description (continued)

8.3.3 Clamp Diodes

The inputs and outputs to this device have negative clamping diodes.

CAUTION

Voltages beyond the values specified in the [Absolute Maximum Ratings](#) table can cause damage to the device. The input negative-voltage and output voltage ratings may be exceeded if the input and output clamp-current ratings are observed.

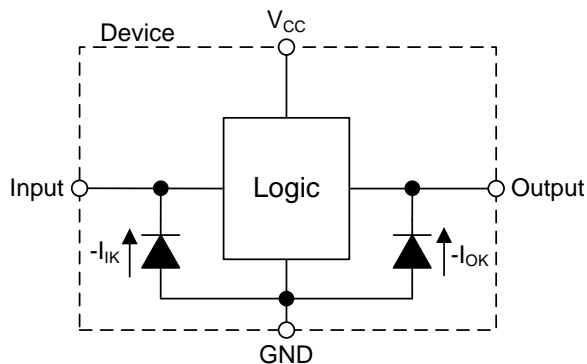

Figure 6. Electrical Placement of Clamping Diodes for Each Input and Output

8.3.4 Partial Power Down (I_{off})

The inputs and outputs for this device enter a high impedance state when the supply voltage is 0 V. The maximum leakage into or out of any input or output pin on the device is specified by I_{off} in the [Electrical Characteristics](#).

8.3.5 Over-Voltage Tolerant Inputs

Input signals to this device can be driven above the supply voltage so long as they remain below the maximum input voltage value specified in the [Absolute Maximum Ratings](#).

8.4 Device Functional Modes

Table 1 lists the functional modes of the SN74LVC1G80.

Table 1. Function Table

| INPUTS | | OUTPUT \bar{Q} |
|--------|---|---------------------|
| CLK | D | |
| ↑ | H | L |
| ↑ | L | H |
| L | X | Q_0 |

9 Application and Implementation

NOTE

Information in the following applications sections is not part of the TI component specification, and TI does not warrant its accuracy or completeness. TI's customers are responsible for determining suitability of components for their purposes. Customers should validate and test their design implementation to confirm system functionality.

9.1 Application Information

A useful application for the SN74LVC1G80 is using it as a frequency divider. By feeding back the output (\overline{Q}) to the input (D), the output will toggle on every rising edge of the clock waveform. The output goes HIGH once every two clock cycles so essentially the frequency of the clock signal is divided by a factor of two. The SN74LVC1G80 does not have preset or clear functions so the initial state of the output is unknown. This application implements the use of a microcontroller GPIO pin to initially set the input HIGH, so the output LOW. Initialization is not needed, but should be kept in mind. Post initialization, the GPIO pin is set to a high impedance mode. Depending on the microcontroller, the GPIO pin could be set to an input and used to monitor the clock division.

9.2 Typical Application

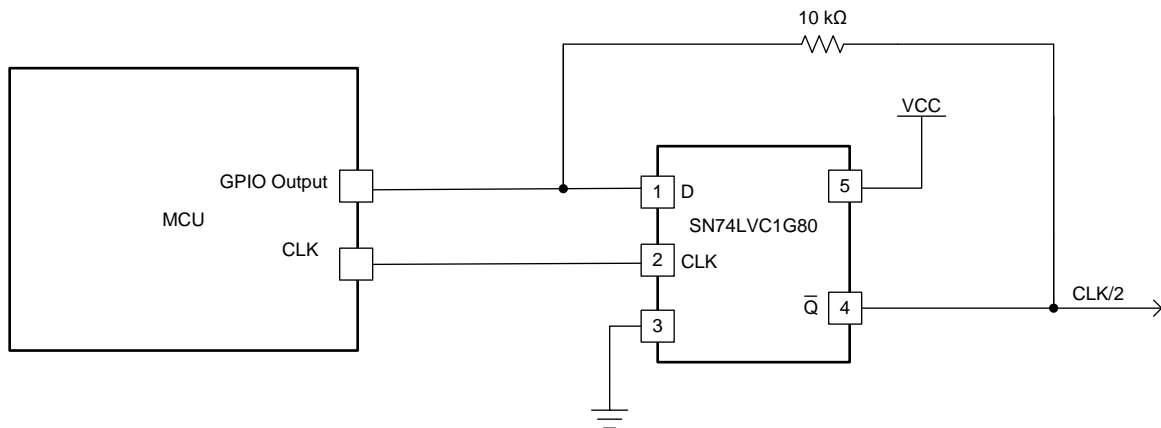

Copyright © 2017, Texas Instruments Incorporated

Figure 7. Clock Frequency Division

9.2.1 Design Requirements

For this application, a resistor needs to be placed on the feedback line in order for the initialization voltage from the microcontroller to overpower the signal coming from the output (\overline{Q}). Without it the state at the input would be challenged by the GPIO from the microcontroller and from the output of the SN74LVC1G80.

The SN74LVC1G80 device uses CMOS technology and has balanced output drive. Take care to avoid bus contention because it can drive currents that would exceed maximum limits.

Typical Application (continued)

9.2.2 Detailed Design Procedure

1. Recommended input conditions:
 - For rise time and fall time specifications, see $\Delta t/\Delta v$ in *Recommended Operating Conditions*.
 - For specified high and low levels, see V_{IH} and V_{IL} in *Recommended Operating Conditions*.
 - Input voltages are recommended to not go below 0 V and not exceed 5.5 V for any V_{CC} . See *Recommended Operating Conditions*.
2. Recommended output conditions:
 - Load currents should not exceed ± 50 mA. See *Absolute Maximum Ratings*.
 - Output voltages are recommended to not go below 0 V and not exceed the V_{CC} voltage. See *Recommended Operating Conditions*.
3. Feedback resistor:
 - A 10-k Ω resistor is chosen here to bias the input so the microcontroller GPIO output can initialize the input and output. The resistor value is important because a resistance too high, say at 1 M Ω , would cause too much of a voltage drop, causing the output to no longer be able to drive the input. On the other hand, a resistor too low, such as a 1 Ω , would not bias enough and might cause current to flow into the microcontroller, possibly damaging the device.

9.2.3 Application Curve

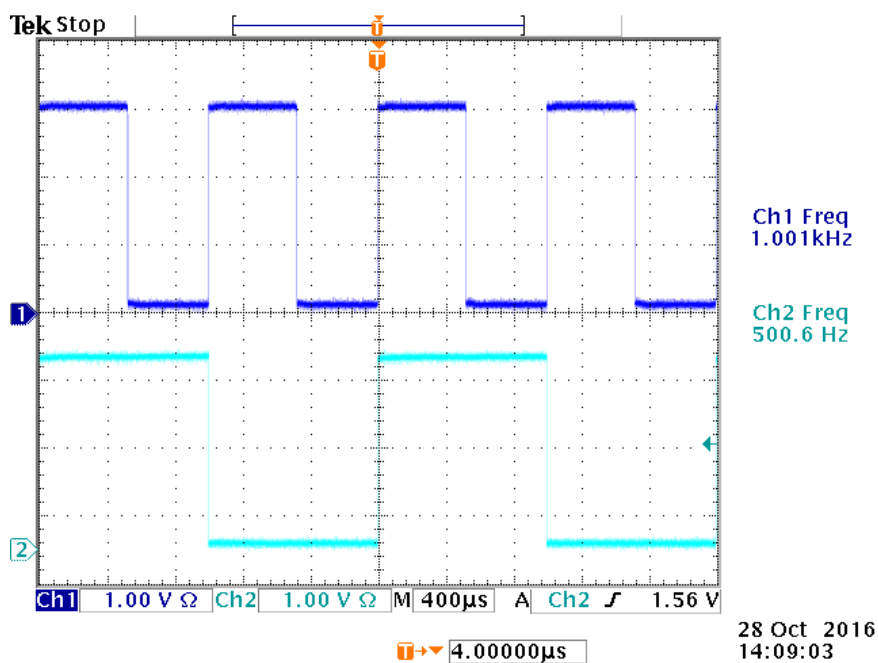

Figure 8. Frequency Division

10 Power Supply Recommendations

The power supply can be any voltage between the minimum and maximum supply voltage rating listed in [Recommended Operating Conditions](#). A 0.1- μF bypass capacitor is recommended to be connected from the VCC terminal to GND to prevent power disturbance. To reject different frequencies of noise, use multiple bypass capacitors in parallel. Capacitors with values of 0.1 μF and 1 μF are commonly used in parallel. The bypass capacitor must be installed as close to the power terminal as possible for best results.

11 Layout

11.1 Layout Guidelines

When a PCB trace turns a corner at a 90° angle, a reflection can occur. A reflection occurs primarily because of the change of width of the trace. At the apex of the turn, the trace width increases to 1.414 times the width. This increase upsets the transmission-line characteristics, especially the distributed capacitance and self-inductance of the trace which results in the reflection. Not all PCB traces can be straight and therefore some traces must turn corners. [Figure 9](#) shows progressively better techniques of rounding corners. Only the last example (BEST) maintains constant trace width and minimizes reflections.

11.2 Layout Example

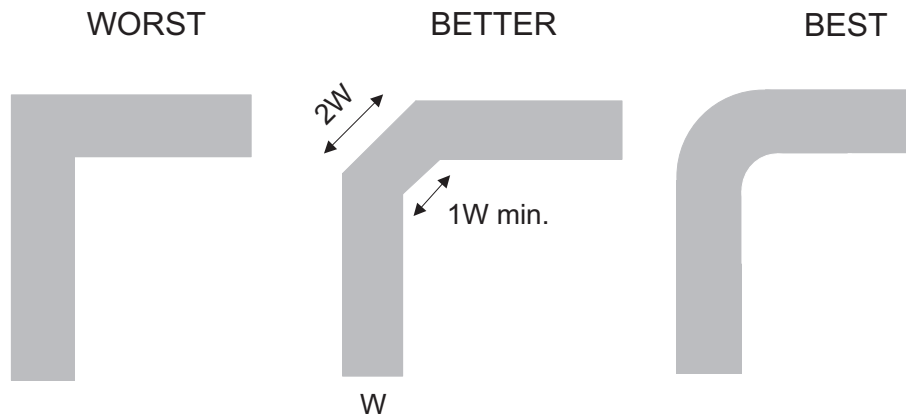

Figure 9. Trace Example

12 器件和文档支持

12.1 文档支持

12.1.1 相关文档

相关文档如下：

《慢速或浮点 CMOS 输入的影响》，SCBA004。

12.2 接收文档更新通知

要接收文档更新通知，请转至 TI.com 上的器件产品文件夹。单击右上角的通知我 进行注册，即可每周接收产品信息更改摘要。有关更改的详细信息，请查看任何已修订文档中包含的修订历史记录。

12.3 社区资源

下列链接提供到 TI 社区资源的连接。链接的内容由各个分销商“按照原样”提供。这些内容并不构成 TI 技术规范，并且不一定反映 TI 的观点；请参阅 TI 的《使用条款》。

TI E2E™ 在线社区 *TI 的工程师对工程师 (E2E) 社区*。此社区的创建目的在于促进工程师之间的协作。在 e2e.ti.com 中，您可以咨询问题、分享知识、拓展思路并与同行工程师一道帮助解决问题。

设计支持 *TI 参考设计支持* 可帮助您快速查找有帮助的 E2E 论坛、设计支持工具以及技术支持的联系信息。

12.4 商标

NanoFree, E2E are trademarks of Texas Instruments.

All other trademarks are the property of their respective owners.

12.5 静电放电警告



这些装置包含有限的内置 ESD 保护。存储或装卸时，应将导线一起截短或将装置放置于导电泡棉中，以防止 MOS 门极遭受静电损伤。

12.6 Glossary

SLYZ022 — *TI Glossary*.

This glossary lists and explains terms, acronyms, and definitions.

13 机械、封装和可订购信息

以下页面包含机械、封装和可订购信息。这些信息是指定器件的最新可用数据。这些数据如有变更，恕不另行通知和修订此文档。如欲获取此数据表的浏览器版本，请参阅左侧的导航。

PACKAGING INFORMATION

| Orderable Device | Status (1) | Package Type | Package Drawing | Pins | Package Qty | Eco Plan (2) | Lead finish/ Ball material (6) | MSL Peak Temp (3) | Op Temp (°C) | Device Marking (4/5) | Samples |
|-------------------|---------------|--------------|-----------------|------|-------------|-----------------|--------------------------------------|----------------------|--------------|---------------------------|-------------------------|
| SN74LVC1G80DBVR | ACTIVE | SOT-23 | DBV | 5 | 3000 | RoHS & Green | NIPDAU SN | Level-1-260C-UNLIM | -40 to 125 | (C805, C80F, C80J, C80R) | Samples |
| SN74LVC1G80DBVRE4 | ACTIVE | SOT-23 | DBV | 5 | 3000 | RoHS & Green | NIPDAU | Level-1-260C-UNLIM | -40 to 125 | C80F | Samples |
| SN74LVC1G80DBVRG4 | ACTIVE | SOT-23 | DBV | 5 | 3000 | RoHS & Green | NIPDAU | Level-1-260C-UNLIM | -40 to 125 | C80F | Samples |
| SN74LVC1G80DBVT | ACTIVE | SOT-23 | DBV | 5 | 250 | RoHS & Green | NIPDAU SN | Level-1-260C-UNLIM | -40 to 125 | (C805, C80F, C80J, C80R) | Samples |
| SN74LVC1G80DBVTG4 | ACTIVE | SOT-23 | DBV | 5 | 250 | RoHS & Green | NIPDAU | Level-1-260C-UNLIM | -40 to 125 | C80F | Samples |
| SN74LVC1G80DCKR | ACTIVE | SC70 | DCK | 5 | 3000 | RoHS & Green | NIPDAU SN | Level-1-260C-UNLIM | -40 to 125 | (CX5, CXF, CXJ, CXK, CXR) | Samples |
| SN74LVC1G80DCKRE4 | ACTIVE | SC70 | DCK | 5 | 3000 | RoHS & Green | NIPDAU | Level-1-260C-UNLIM | -40 to 125 | CX5 | Samples |
| SN74LVC1G80DCKRG4 | ACTIVE | SC70 | DCK | 5 | 3000 | RoHS & Green | NIPDAU | Level-1-260C-UNLIM | -40 to 125 | CX5 | Samples |
| SN74LVC1G80DCKT | ACTIVE | SC70 | DCK | 5 | 250 | RoHS & Green | NIPDAU SN | Level-1-260C-UNLIM | -40 to 125 | (CX5, CXF, CXJ, CXK, CXR) | Samples |
| SN74LVC1G80YZPR | ACTIVE | DSBGA | YZP | 5 | 3000 | RoHS & Green | SNAGCU | Level-1-260C-UNLIM | -40 to 85 | (CX7, CXN) | Samples |

(1) The marketing status values are defined as follows:

ACTIVE: Product device recommended for new designs.

LIFEBUY: TI has announced that the device will be discontinued, and a lifetime-buy period is in effect.

NRND: Not recommended for new designs. Device is in production to support existing customers, but TI does not recommend using this part in a new design.

PREVIEW: Device has been announced but is not in production. Samples may or may not be available.

OBSELETE: TI has discontinued the production of the device.

(2) **RoHS:** TI defines "RoHS" to mean semiconductor products that are compliant with the current EU RoHS requirements for all 10 RoHS substances, including the requirement that RoHS substance do not exceed 0.1% by weight in homogeneous materials. Where designed to be soldered at high temperatures, "RoHS" products are suitable for use in specified lead-free processes. TI may reference these types of products as "Pb-Free".

RoHS Exempt: TI defines "RoHS Exempt" to mean products that contain lead but are compliant with EU RoHS pursuant to a specific EU RoHS exemption.

Green: TI defines "Green" to mean the content of Chlorine (Cl) and Bromine (Br) based flame retardants meet JS709B low halogen requirements of <=1000ppm threshold. Antimony trioxide based flame retardants must also meet the <=1000ppm threshold requirement.

(3) MSL, Peak Temp. - The Moisture Sensitivity Level rating according to the JEDEC industry standard classifications, and peak solder temperature.

(4) There may be additional marking, which relates to the logo, the lot trace code information, or the environmental category on the device.

(5) Multiple Device Markings will be inside parentheses. Only one Device Marking contained in parentheses and separated by a "~" will appear on a device. If a line is indented then it is a continuation of the previous line and the two combined represent the entire Device Marking for that device.

(6) Lead finish/Ball material - Orderable Devices may have multiple material finish options. Finish options are separated by a vertical ruled line. Lead finish/Ball material values may wrap to two lines if the finish value exceeds the maximum column width.

Important Information and Disclaimer:The information provided on this page represents TI's knowledge and belief as of the date that it is provided. TI bases its knowledge and belief on information provided by third parties, and makes no representation or warranty as to the accuracy of such information. Efforts are underway to better integrate information from third parties. TI has taken and continues to take reasonable steps to provide representative and accurate information but may not have conducted destructive testing or chemical analysis on incoming materials and chemicals. TI and TI suppliers consider certain information to be proprietary, and thus CAS numbers and other limited information may not be available for release.

In no event shall TI's liability arising out of such information exceed the total purchase price of the TI part(s) at issue in this document sold by TI to Customer on an annual basis.

TAPE AND REEL INFORMATION



QUADRANT ASSIGNMENTS FOR PIN 1 ORIENTATION IN TAPE



*All dimensions are nominal

| Device | Package Type | Package Drawing | Pins | SPQ | Reel Diameter (mm) | Reel Width W1 (mm) | A0 (mm) | B0 (mm) | K0 (mm) | P1 (mm) | W (mm) | Pin1 Quadrant |
|-------------------|--------------|-----------------|------|------|--------------------|--------------------|---------|---------|---------|---------|--------|---------------|
| SN74LVC1G80DBVR | SOT-23 | DBV | 5 | 3000 | 178.0 | 9.2 | 3.3 | 3.23 | 1.55 | 4.0 | 8.0 | Q3 |
| SN74LVC1G80DBVR | SOT-23 | DBV | 5 | 3000 | 178.0 | 9.0 | 3.23 | 3.17 | 1.37 | 4.0 | 8.0 | Q3 |
| SN74LVC1G80DBVR | SOT-23 | DBV | 5 | 3000 | 180.0 | 8.4 | 3.23 | 3.17 | 1.37 | 4.0 | 8.0 | Q3 |
| SN74LVC1G80DBVR | SOT-23 | DBV | 5 | 3000 | 178.0 | 9.0 | 3.3 | 3.2 | 1.4 | 4.0 | 8.0 | Q3 |
| SN74LVC1G80DBVRG4 | SOT-23 | DBV | 5 | 3000 | 178.0 | 9.0 | 3.23 | 3.17 | 1.37 | 4.0 | 8.0 | Q3 |
| SN74LVC1G80DBVT | SOT-23 | DBV | 5 | 250 | 180.0 | 8.4 | 3.23 | 3.17 | 1.37 | 4.0 | 8.0 | Q3 |
| SN74LVC1G80DBVT | SOT-23 | DBV | 5 | 250 | 178.0 | 9.2 | 3.3 | 3.23 | 1.55 | 4.0 | 8.0 | Q3 |
| SN74LVC1G80DBVT | SOT-23 | DBV | 5 | 250 | 178.0 | 9.0 | 3.3 | 3.2 | 1.4 | 4.0 | 8.0 | Q3 |
| SN74LVC1G80DBVT | SOT-23 | DBV | 5 | 250 | 178.0 | 9.0 | 3.3 | 3.2 | 1.4 | 4.0 | 8.0 | Q3 |
| SN74LVC1G80DBVTG4 | SOT-23 | DBV | 5 | 250 | 178.0 | 9.0 | 3.23 | 3.17 | 1.37 | 4.0 | 8.0 | Q3 |
| SN74LVC1G80DCKR | SC70 | DCK | 5 | 3000 | 178.0 | 9.2 | 2.4 | 2.4 | 1.22 | 4.0 | 8.0 | Q3 |
| SN74LVC1G80DCKR | SC70 | DCK | 5 | 3000 | 180.0 | 8.4 | 2.47 | 2.3 | 1.25 | 4.0 | 8.0 | Q3 |
| SN74LVC1G80DCKR | SC70 | DCK | 5 | 3000 | 178.0 | 9.0 | 2.4 | 2.5 | 1.2 | 4.0 | 8.0 | Q3 |
| SN74LVC1G80DCKRG4 | SC70 | DCK | 5 | 3000 | 178.0 | 9.2 | 2.4 | 2.4 | 1.22 | 4.0 | 8.0 | Q3 |
| SN74LVC1G80DCKT | SC70 | DCK | 5 | 250 | 178.0 | 9.0 | 2.4 | 2.5 | 1.2 | 4.0 | 8.0 | Q3 |
| SN74LVC1G80DCKT | SC70 | DCK | 5 | 250 | 178.0 | 9.2 | 2.4 | 2.4 | 1.22 | 4.0 | 8.0 | Q3 |
| SN74LVC1G80YZPR | DSBGA | YZP | 5 | 3000 | 178.0 | 9.2 | 1.02 | 1.52 | 0.63 | 4.0 | 8.0 | Q1 |

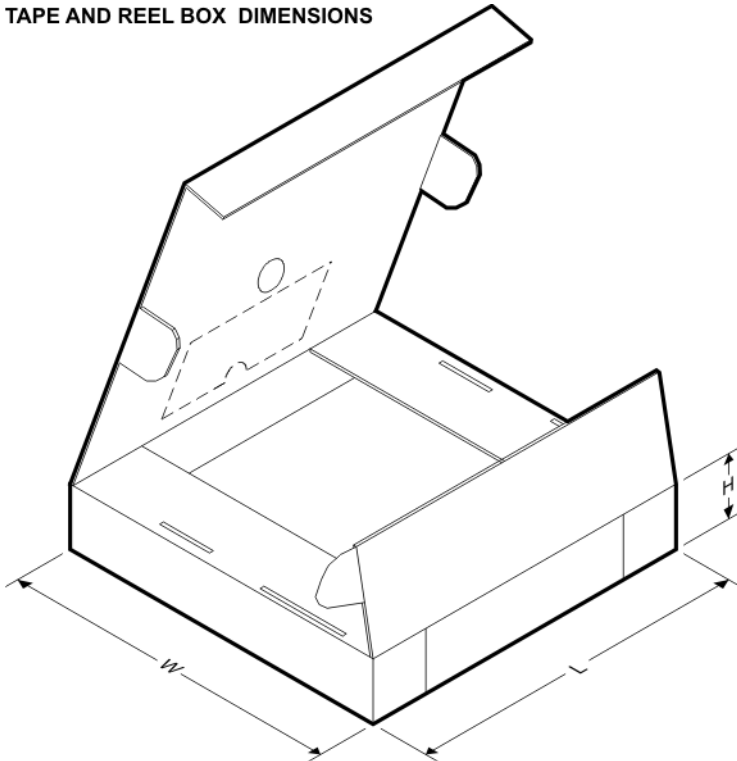
TAPE AND REEL BOX DIMENSIONS

*All dimensions are nominal

| Device | Package Type | Package Drawing | Pins | SPQ | Length (mm) | Width (mm) | Height (mm) |
|-------------------|--------------|-----------------|------|------|-------------|------------|-------------|
| SN74LVC1G80DBVR | SOT-23 | DBV | 5 | 3000 | 180.0 | 180.0 | 18.0 |
| SN74LVC1G80DBVR | SOT-23 | DBV | 5 | 3000 | 180.0 | 180.0 | 18.0 |
| SN74LVC1G80DBVR | SOT-23 | DBV | 5 | 3000 | 202.0 | 201.0 | 28.0 |
| SN74LVC1G80DBVR | SOT-23 | DBV | 5 | 3000 | 180.0 | 180.0 | 18.0 |
| SN74LVC1G80DBVRG4 | SOT-23 | DBV | 5 | 3000 | 180.0 | 180.0 | 18.0 |
| SN74LVC1G80DBVT | SOT-23 | DBV | 5 | 250 | 202.0 | 201.0 | 28.0 |
| SN74LVC1G80DBVT | SOT-23 | DBV | 5 | 250 | 180.0 | 180.0 | 18.0 |
| SN74LVC1G80DBVT | SOT-23 | DBV | 5 | 250 | 180.0 | 180.0 | 18.0 |
| SN74LVC1G80DBVT | SOT-23 | DBV | 5 | 250 | 180.0 | 180.0 | 18.0 |
| SN74LVC1G80DBVTG4 | SOT-23 | DBV | 5 | 250 | 180.0 | 180.0 | 18.0 |
| SN74LVC1G80DCKR | SC70 | DCK | 5 | 3000 | 180.0 | 180.0 | 18.0 |
| SN74LVC1G80DCKR | SC70 | DCK | 5 | 3000 | 202.0 | 201.0 | 28.0 |
| SN74LVC1G80DCKR | SC70 | DCK | 5 | 3000 | 180.0 | 180.0 | 18.0 |
| SN74LVC1G80DCKRG4 | SC70 | DCK | 5 | 3000 | 180.0 | 180.0 | 18.0 |
| SN74LVC1G80DCKT | SC70 | DCK | 5 | 250 | 180.0 | 180.0 | 18.0 |
| SN74LVC1G80DCKT | SC70 | DCK | 5 | 250 | 180.0 | 180.0 | 18.0 |
| SN74LVC1G80YZPR | DSBGA | YZP | 5 | 3000 | 220.0 | 220.0 | 35.0 |

DCK (R-PDSO-G5)

PLASTIC SMALL-OUTLINE PACKAGE



- NOTES:
- A. All linear dimensions are in millimeters.
 - B. This drawing is subject to change without notice.
 - C. Body dimensions do not include mold flash or protrusion. Mold flash and protrusion shall not exceed 0.15 per side.
 - D. Falls within JEDEC MO-203 variation AA.

DCK (R-PDSO-G5)

PLASTIC SMALL OUTLINE



- NOTES:
- All linear dimensions are in millimeters.
 - This drawing is subject to change without notice.
 - Customers should place a note on the circuit board fabrication drawing not to alter the center solder mask defined pad.
 - Publication IPC-7351 is recommended for alternate designs.
 - Laser cutting apertures with trapezoidal walls and also rounding corners will offer better paste release. Customers should contact their board assembly site for stencil design recommendations. Example stencil design based on a 50% volumetric metal load solder paste. Refer to IPC-7525 for other stencil recommendations.

EXAMPLE BOARD LAYOUT

DBV0005A

SOT-23 - 1.45 mm max height

SMALL OUTLINE TRANSISTOR

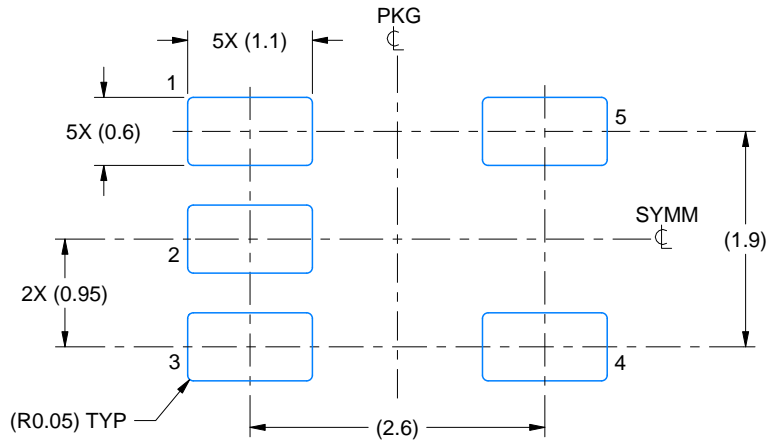

LAND PATTERN EXAMPLE
EXPOSED METAL SHOWN
SCALE:15X

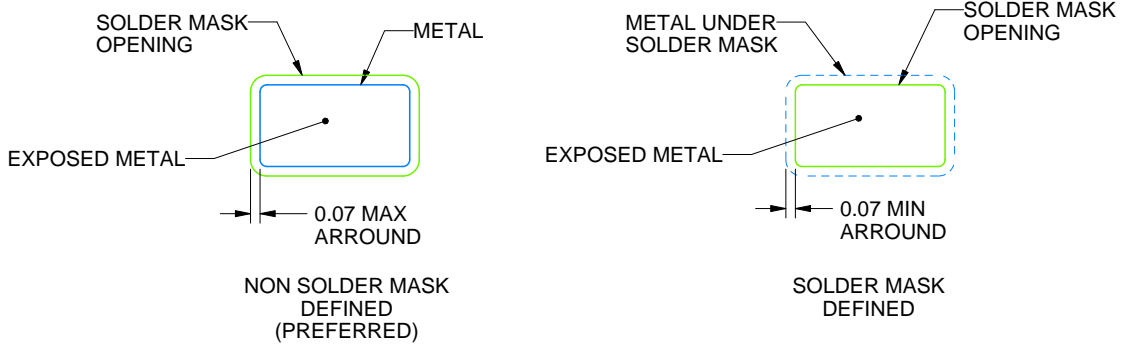

SOLDER MASK DETAILS

4214839/F 06/2021

NOTES: (continued)

- 5. Publication IPC-7351 may have alternate designs.
- 6. Solder mask tolerances between and around signal pads can vary based on board fabrication site.

EXAMPLE STENCIL DESIGN

DBV0005A

SOT-23 - 1.45 mm max height

SMALL OUTLINE TRANSISTOR

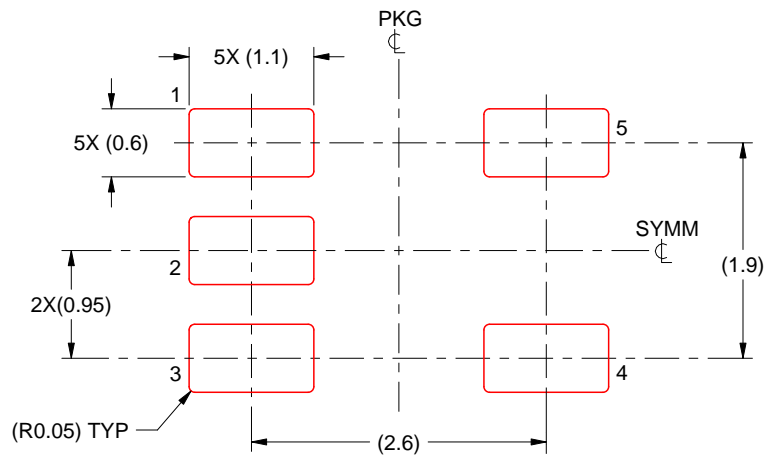

SOLDER PASTE EXAMPLE
BASED ON 0.125 mm THICK STENCIL
SCALE:15X

4214839/F 06/2021

NOTES: (continued)

7. Laser cutting apertures with trapezoidal walls and rounded corners may offer better paste release. IPC-7525 may have alternate design recommendations.
8. Board assembly site may have different recommendations for stencil design.

YZP0005



PACKAGE OUTLINE

DSBGA - 0.5 mm max height

DIE SIZE BALL GRID ARRAY

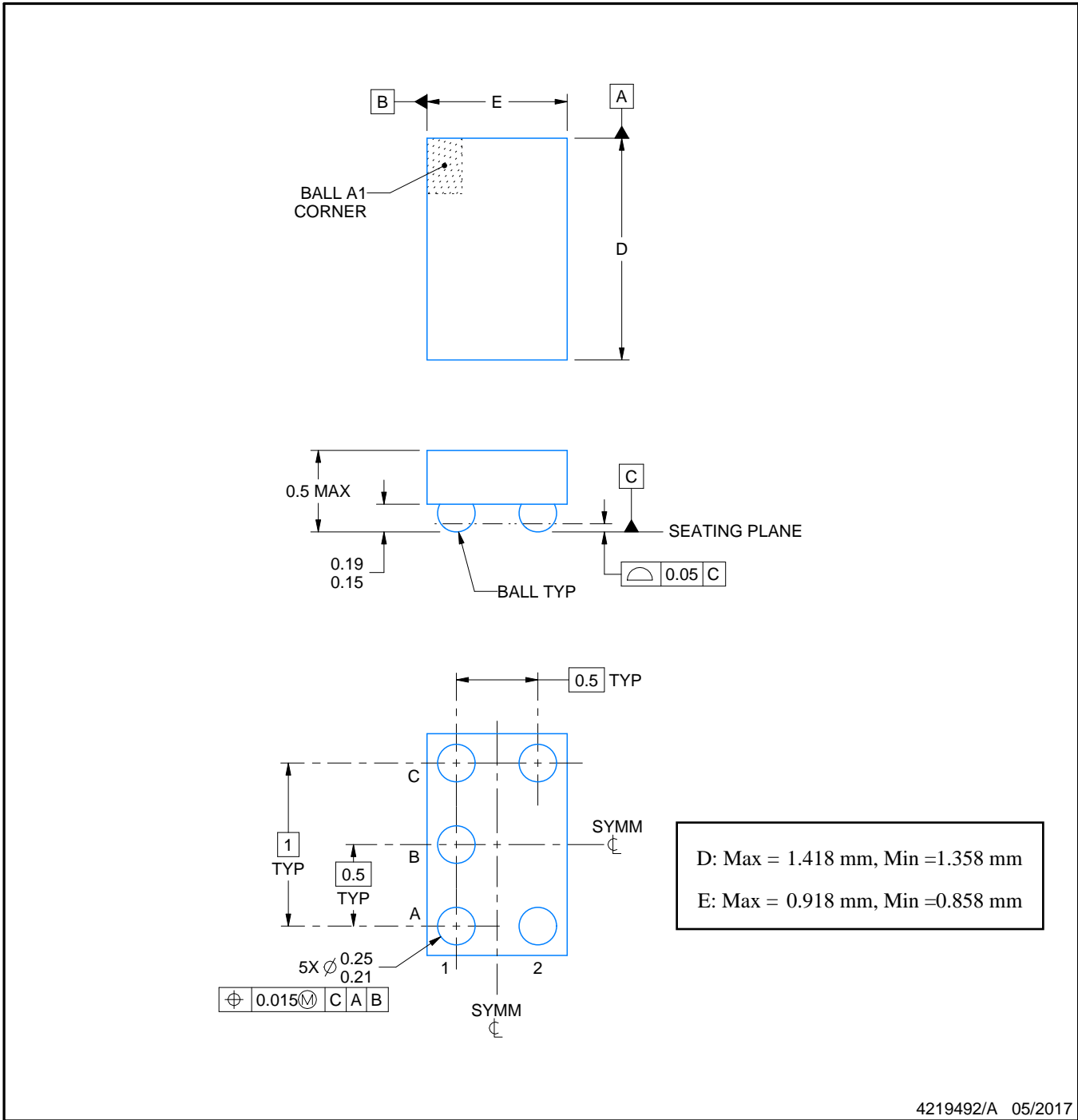

NOTES:

1. All linear dimensions are in millimeters. Any dimensions in parenthesis are for reference only. Dimensioning and tolerancing per ASME Y14.5M.
2. This drawing is subject to change without notice.

EXAMPLE BOARD LAYOUT

YZP0005

DSBGA - 0.5 mm max height

DIE SIZE BALL GRID ARRAY



LAND PATTERN EXAMPLE
SCALE:40X



SOLDER MASK DETAILS
NOT TO SCALE

4219492/A 05/2017

NOTES: (continued)

3. Final dimensions may vary due to manufacturing tolerance considerations and also routing constraints. For more information, see Texas Instruments literature number SNVA009 (www.ti.com/lit/snva009).

EXAMPLE STENCIL DESIGN

YZP0005

DSBGA - 0.5 mm max height

DIE SIZE BALL GRID ARRAY



SOLDER PASTE EXAMPLE
BASED ON 0.1 mm THICK STENCIL
SCALE:40X

4219492/A 05/2017

NOTES: (continued)

4. Laser cutting apertures with trapezoidal walls and rounded corners may offer better paste release.

重要声明和免责声明

TI“按原样”提供技术和可靠性数据（包括数据表）、设计资源（包括参考设计）、应用或其他设计建议、网络工具、安全信息和其他资源，不保证没有瑕疵且不做任何明示或暗示的担保，包括但不限于对适销性、某特定用途方面的适用性或不侵犯任何第三方知识产权的暗示担保。

这些资源可供使用 TI 产品进行设计的熟练开发人员使用。您将自行承担以下全部责任：(1) 针对您的应用选择合适的 TI 产品，(2) 设计、验证并测试您的应用，(3) 确保您的应用满足相应标准以及任何其他功能安全、信息安全、监管或其他要求。

这些资源如有变更，恕不另行通知。TI 授权您仅可将这些资源用于研发本资源所述的 TI 产品的应用。严禁对这些资源进行其他复制或展示。您无权使用任何其他 TI 知识产权或任何第三方知识产权。您应全额赔偿因在这些资源的使用中对 TI 及其代表造成的任何索赔、损害、成本、损失和债务，TI 对此概不负责。

TI 提供的产品受 [TI 的销售条款](#) 或 [ti.com](#) 上其他适用条款/TI 产品随附的其他适用条款的约束。TI 提供这些资源并不会扩展或以其他方式更改 TI 针对 TI 产品发布的适用的担保或担保免责声明。

TI 反对并拒绝您可能提出的任何其他或不同的条款。

邮寄地址：Texas Instruments, Post Office Box 655303, Dallas, Texas 75265

Copyright © 2022，德州仪器 (TI) 公司