

FEATURES

- Low Output Skew, Low Pulse Skew for Clock-Distribution and Clock-Generation Applications
- Operates at 3.3-V V_{CC}
- LVTTTL-Compatible Inputs and Outputs
- Supports Mixed-Mode Signal Operation (5-V Input and Output Voltages With 3.3-V V_{CC})
- Distributes One Clock Input to Ten Outputs
- Distributed V_{CC} and Ground Pins Reduce Switching Noise
- High-Drive Outputs ($-32\text{-mA } I_{OH}$, $32\text{-mA } I_{OL}$)
- State-of-the-Art EPIC-IIB™ BiCMOS Design Significantly Reduces Power Dissipation
- Package Options Include Plastic Small-Outline (DW) and Shrink Small-Outline (DB) Packages

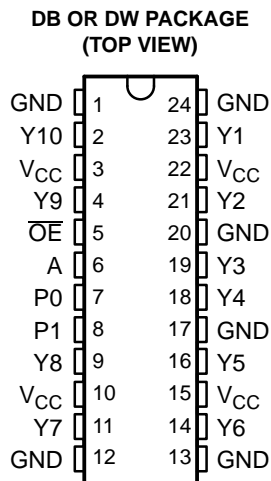

DESCRIPTION

The CDC351 is a high-performance clock-driver circuit that distributes one input (A) to ten outputs (Y) with minimum skew for clock distribution. The output-enable (\overline{OE}) input disables the outputs to a high-impedance state. The CDC351 operates at nominal 3.3-V V_{CC} .

The propagation delays are adjusted at the factory using the P0 and P1 pins. The factory adjustments ensure that the part-to-part skew is minimized and is kept within a specified window. Pins P0 and P1 are not intended for customer use and should be connected to GND.

FUNCTION TABLE

INPUTS		OUTPUTS
A	\overline{OE}	Y_n
L	H	Z
H	H	Z
L	L	L
H	L	H

AVAILABLE OPTIONS

T_A	Shrink Small-Outline Package (DB) (1)	Small-Outline Package (DW) (1)
0°C to 70°C	CDC351DB	CDC351DW
-40°C to 85°C	CDC351IDB	CDC351IDW

(1) This package is available tape and reel. Order by adding an R to the orderable part number (e.g., CDC351DBR).

EPIC-IIB is a trademark of Texas Instruments.



Please be aware that an important notice concerning availability, standard warranty, and use in critical applications of Texas Instruments semiconductor products and disclaimers thereto appears at the end of this data sheet.

CDC351. CDC351I 1-LINE TO 10-LINE CLOCK DRIVER WITH 3-STATE OUTPUTS

SCAS441D—FEBRUARY 1994—REVISED OCTOBER 2003

LOGIC SYMBOL ^A

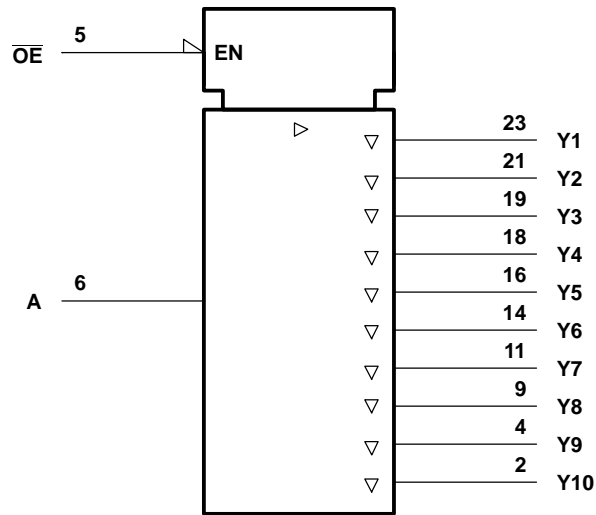

Note A: This symbol is in accordance with ANSI/IEEE Std 91-1984 and IEC Publication 617-12.

LOGIC DIAGRAM (POSITIVE LOGIC)

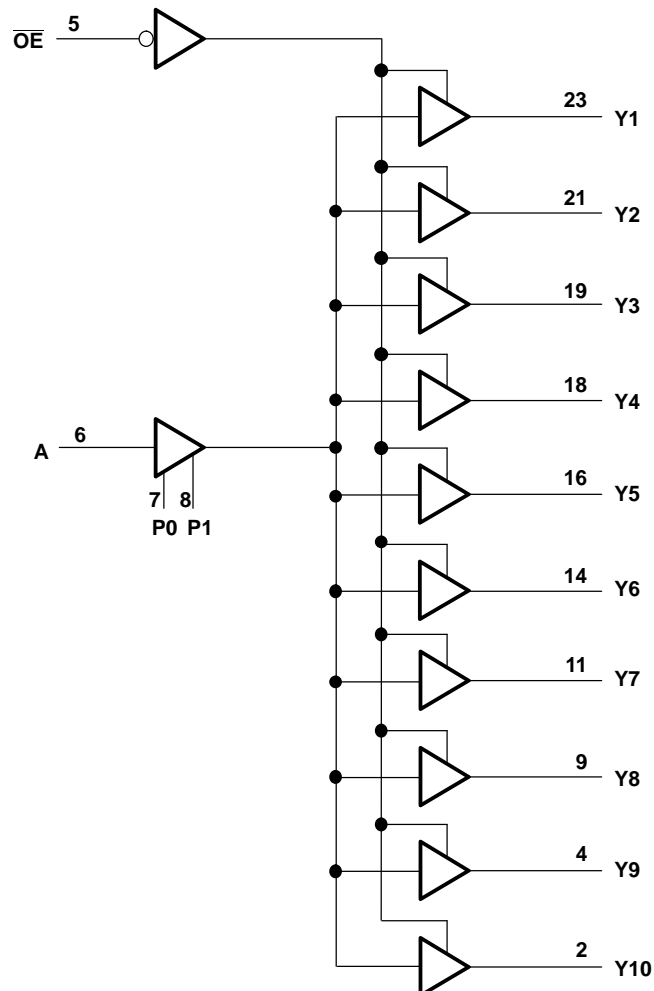

ABSOLUTE MAXIMUM RATINGS

over operating free-air temperature range (unless otherwise noted) (1)

Supply voltage range, V_{CC}		– 0.5 V to 4.6 V
Input voltage range, V_I (2)		– 0.5 V to 7 V
Voltage range applied to any output in the high state or power-off state, V_O (2)		– 0.5 V to 3.6 V
Current into any output in the low state, I_O		64 mA
Input clamp current, $I_{IK}(V_I < 0)$		– 18 mA
Output clamp current, $I_{OK}(V_I < 0)$		– 50 mA
Package thermal impedance Θ_{JA} (3):	DB package	147°C/ W
	DW package	101°C/ W
Storage temperature range, T_{stg}		– 65°C to 150°C

- (1) Stresses beyond those listed under „ absolute maximum ratings” may cause permanent damage to the device. These are stress ratings only, and functional operation of the device at these or any other conditions beyond those indicated under „ recommended operating conditions” is not implied. Exposure to absolute-maximum-rated conditions for extended periods may affect device reliability.
- (2) The input and output negative-voltage ratings may be exceeded if the input and output clamp-current ratings are observed.
- (3) The package thermal impedance is calculated in accordance with JESD51.

RECOMMENDED OPERATING CONDITIONS (1)

		MIN	MAX	UNIT	
V_{CC}	Supply voltage	3	3.6	V	
V_{IH}	High-level input voltage	2		V	
V_{IL}	Low-level input voltage		0.8	V	
V_I	Input voltage	0	5.5	V	
I_{OH}	High-level output current		– 32	mA	
I_{OL}	Low-level output current		32	mA	
f_{clock}	Input clock frequency		100	MHz	
T_A	Operating free-air temperature	Commercial	0	70	°C
		Industrial	– 40	85	°C

- (1) Unused pins (input or I/O) must be held high or low.

ELECTRICAL CHARACTERISTICS

over recommended operating free-air temperature range (unless otherwise noted)

PARAMETER	TEST CONDITIONS		MIN	TYP	MAX	UNIT
V_{IK}	$V_{CC} = 3\text{ V}$,	$I_I = -18\text{ mA}$			–1.2	V
V_{OH}	$V_{CC} = 3\text{ V}$,	$I_{OH} = -32\text{ mA}$	2			V
V_{OL}	$V_{CC} = 3\text{ V}$,	$I_{OL} = 32\text{ mA}$			0.5	V
I_I	$V_{CC} = 3.6\text{ V}$,	$V_I = V_{CC}$ or GND			± 1	μA
I_O (1)	$V_{CC} = 3.6\text{ V}$,	$V_O = 2.5\text{ V}$	–15		–150	mA
I_{oz}	$V_{CC} = 3.6\text{ V}$,	$V_O = 3\text{ V}$ or 0			± 10	μA
I_{CC}	$V_{CC} = 3.6\text{ V}$, $I_O = 0$, $V_I = V_{CC}$ or GND	Outputs high			0.3	mA
		Outputs low			25	
		Outputs disabled			0.3	
C_i	$V_I = V_{CC}$ or GND,	$V_{CC} = 3.3\text{ V}$,		4		pF
C_o	$V_O = V_{CC}$ or GND,	$V_{CC} = 3.3\text{ V}$,		6		pF

- (1) Not more than one output should be tested at a time, and the duration of the test should not exceed one second.

CDC351. CDC351I

1-LINE TO 10-LINE CLOCK DRIVER WITH 3-STATE OUTPUTS

SCAS441D—FEBRUARY 1994—REVISED OCTOBER 2003

SWITCHING CHARACTERISTICS

$C_L = 50$ pF (see Figure 1 and Figure 2)

PARAMETER	FROM (INPUT)	TO (OUTPUT)	$V_{CC} = 3.3$ V, $T_A = 25^\circ\text{C}$			$V_{CC} = 3$ V to 3.6 V, $T_A = 0^\circ\text{C}$ to 70°C		$V_{CC} = 3$ V to 3.6 V, $T_A = -40^\circ\text{C}$ to 85°C		UNIT
			MIN	TYP	MAX	MIN	MAX	MIN	MAX	
t_{PLH}	A	Y	3.2	3.7	4.2					ns
t_{PHL}			3	3.5	4					
t_{PZH}	\overline{OE}	Y	1.8	3.8	5.5	1.3	5.9	1.1	6.1	ns
t_{PZL}			1.8	3.8	5.5	1.3	5.9	1.1	6.1	
t_{PHZ}	\overline{OE}	Y	1.8	3.9	5.9	1.7	6.3	1.5	6.5	ns
t_{PLZ}			1.8	4.2	5.9	1.7	6.4	1.5	6.6	
$t_{sk(o)}$	A	Y		0.3	0.5		0.5		0.6	ns
$t_{sk(p)}$	A	Y		0.2	0.8		0.8		0.9	ns
$t_{sk(pr)}$	A	Y			1		1		1.1	ns
t_r	A	Y					1.5		1.5	ns
t_f	A	Y					1.5		1.5	ns

SWITCHING CHARACTERISTICS TEMPERATURE AND V_{CC} COEFFICIENTS

over recommended operating free-air temperature and V_{CC} range (1)

PARAMETER		FROM (INPUT)	TO (OUTPUT)	MIN	MAX	UNIT
$\$t_{PLH}(T)$	Average temperature coefficient of low to high propagation delay	A	Y		65 (2)	ps/ 10°C
$\$t_{PHL}(T)$	Average temperature coefficient of high to low propagation delay	A	Y		45 (2)	ps/ 10°C
$\$t_{PLH}(V_{CC})$	Average V_{CC} coefficient of low to high propagation delay	A	Y	-140 (3)		ps/ 100 mV
$\$t_{PHL}(V_{CC})$	Average V_{CC} coefficient of high to low propagation delay	A	Y	-120 (3)		ps/ 100 mV

- (1) These data were extracted from characterization material and are not tested at the factory.
- (2) $\$t_{PLH}(T)$ and $\$t_{PHL}(T)$ are virtually independent of V_{CC} .
- (3) $\$t_{PLH}(V_{CC})$ and $\$t_{PHL}(V_{CC})$ are virtually independent of temperature.

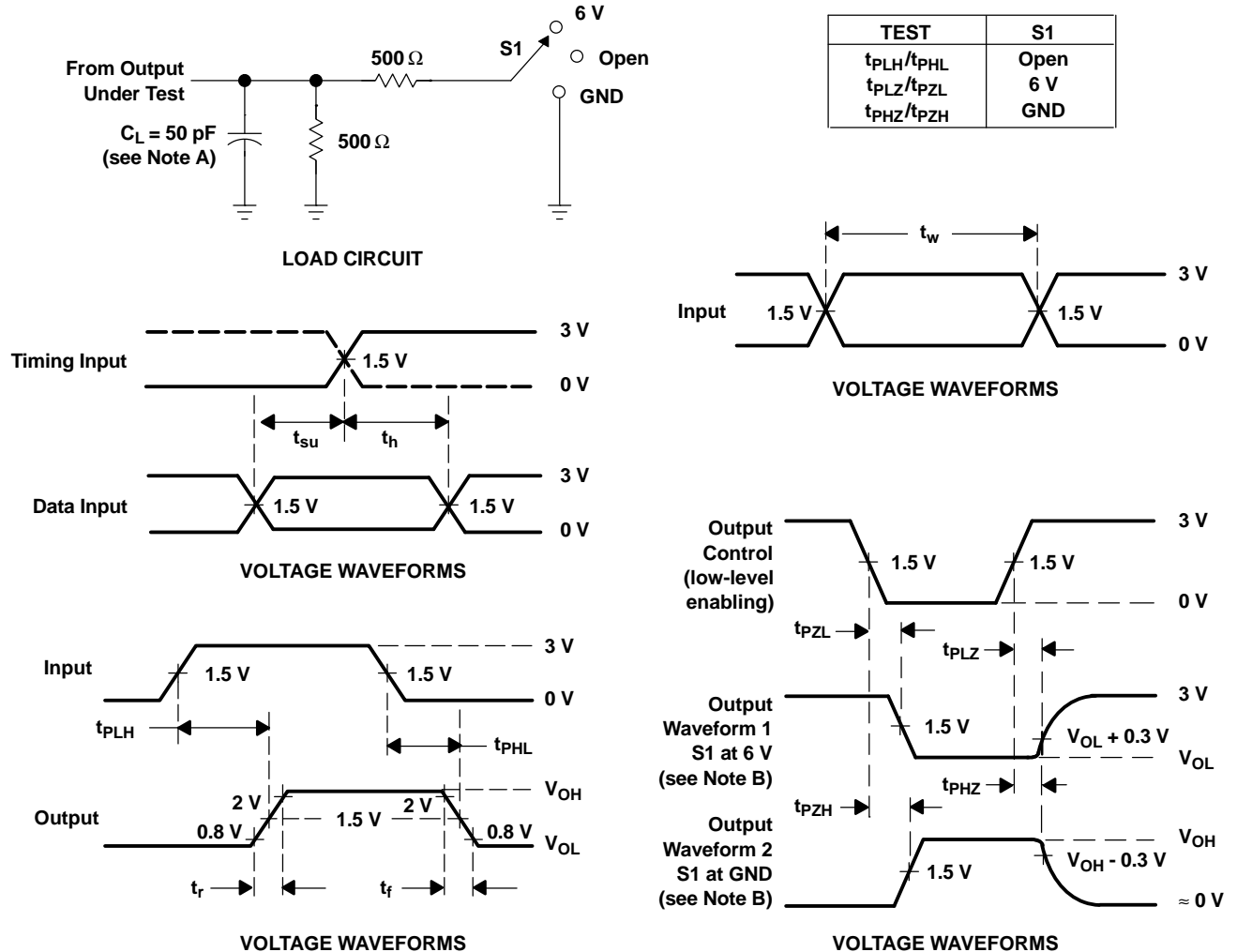

A. C_L includes probe and jig capacitance.

B. Waveform 1 is for an output with internal conditions such that the output is low except when disabled by the output control. Waveform 2 is for an output with internal conditions such that the output is high except when disabled by the output control.

C. All input pulses are supplied by generators having the following characteristics: $PRR \leq 10 \text{ MHz}$, $Z_O = 50 \Omega$, $t_r \leq 2.5 \text{ ns}$, $t_f \leq 2.5 \text{ ns}$.

D. The outputs are measured one at a time with one transition per measurement.

Figure 1. Load Circuit and Voltage Waveforms

CDC351. CDC351I 1-LINE TO 10-LINE CLOCK DRIVER WITH 3-STATE OUTPUTS

SCAS441D—FEBRUARY 1994—REVISED OCTOBER 2003

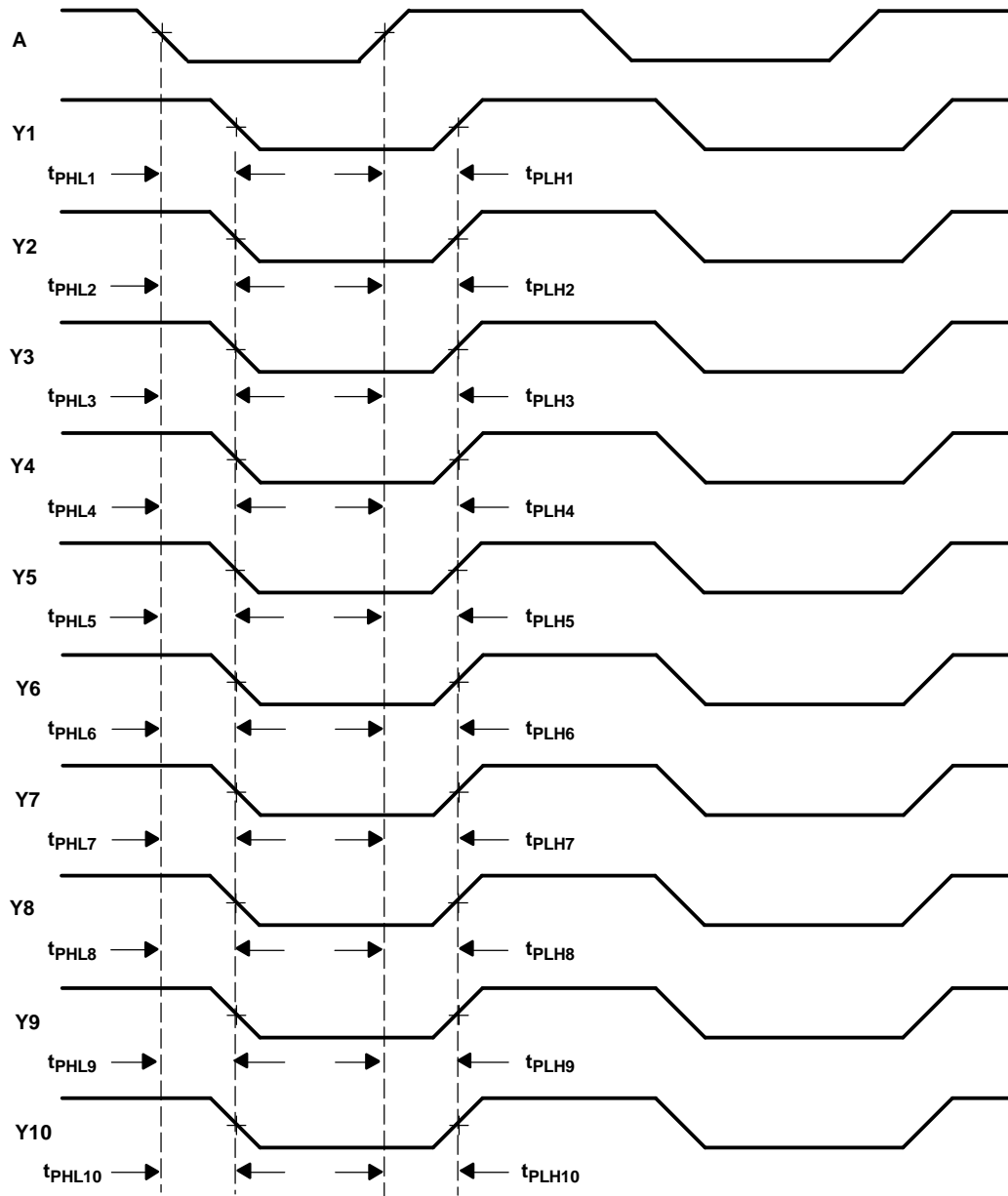

- A. Output skew, $t_{sk(o)}$, is calculated as the greater of:
- The difference between the fastest and slowest of t_{PLHn} ($n = 1, 2, 3, 4, 5, 6, 7, 8, 9, 10$)
 - The difference between the fastest and slowest of t_{PHLn} ($n = 1, 2, 3, 4, 5, 6, 7, 8, 9, 10$)
- B. Pulse skew, $t_{sk(p)}$, is calculated as the greater of $|t_{PLHn} - t_{PHLn}|$ ($n = 1, 2, 3, 4, 5, 6, 7, 8, 9, 10$).
- C. Process skew, $t_{sk(pr)}$, is calculated as the greater of:
- The difference between the fastest and slowest of t_{PLHn} ($n = 1, 2, 3, 4, 5, 6, 7, 8, 9, 10$) across multiple devices under identical operating conditions
 - The difference between the fastest and slowest of t_{PHLn} ($n = 1, 2, 3, 4, 5, 6, 7, 8, 9, 10$) across multiple devices under identical operating conditions

Figure 2. Waveforms for Calculation of $t_{sk(o)}$, $t_{sk(p)}$, $t_{sk(pr)}$

PACKAGING INFORMATION

Orderable Device	Status (1)	Package Type	Package Drawing	Pins	Package Qty	Eco Plan (2)	Lead finish/ Ball material (6)	MSL Peak Temp (3)	Op Temp (°C)	Device Marking (4/5)	Samples
CDC351DB	ACTIVE	SSOP	DB	24	60	RoHS & Green	NIPDAU	Level-1-260C-UNLIM	0 to 70	CK351	Samples
CDC351DBR	ACTIVE	SSOP	DB	24	2000	RoHS & Green	NIPDAU	Level-1-260C-UNLIM	0 to 70	CK351	Samples
CDC351DBRG4	ACTIVE	SSOP	DB	24	2000	RoHS & Green	NIPDAU	Level-1-260C-UNLIM	0 to 70	CK351	Samples
CDC351DW	ACTIVE	SOIC	DW	24	25	RoHS & Green	NIPDAU	Level-1-260C-UNLIM	0 to 70	CDC351	Samples
CDC351DWG4	ACTIVE	SOIC	DW	24	25	RoHS & Green	NIPDAU	Level-1-260C-UNLIM	0 to 70	CDC351	Samples
CDC351DWR	ACTIVE	SOIC	DW	24	2000	RoHS & Green	NIPDAU	Level-1-260C-UNLIM	0 to 70	CDC351	Samples
CDC351DWRG4	ACTIVE	SOIC	DW	24	2000	RoHS & Green	NIPDAU	Level-1-260C-UNLIM	0 to 70	CDC351	Samples
CDC351IDB	ACTIVE	SSOP	DB	24	60	RoHS & Green	NIPDAU	Level-1-260C-UNLIM	-40 to 85	CK351-I	Samples
CDC351IDBG4	ACTIVE	SSOP	DB	24	60	RoHS & Green	NIPDAU	Level-1-260C-UNLIM	-40 to 85	CK351-I	Samples
CDC351IDBR	ACTIVE	SSOP	DB	24	2000	RoHS & Green	NIPDAU	Level-1-260C-UNLIM	-40 to 85	CK351-I	Samples
CDC351IDW	ACTIVE	SOIC	DW	24	25	RoHS & Green	NIPDAU	Level-1-260C-UNLIM	-40 to 85	CDC351-I	Samples
CDC351IDWG4	ACTIVE	SOIC	DW	24	25	RoHS & Green	NIPDAU	Level-1-260C-UNLIM	-40 to 85	CDC351-I	Samples

(1) The marketing status values are defined as follows:

ACTIVE: Product device recommended for new designs.

LIFEBUY: TI has announced that the device will be discontinued, and a lifetime-buy period is in effect.

NRND: Not recommended for new designs. Device is in production to support existing customers, but TI does not recommend using this part in a new design.

PREVIEW: Device has been announced but is not in production. Samples may or may not be available.

OBSOLETE: TI has discontinued the production of the device.

(2) **RoHS:** TI defines "RoHS" to mean semiconductor products that are compliant with the current EU RoHS requirements for all 10 RoHS substances, including the requirement that RoHS substance do not exceed 0.1% by weight in homogeneous materials. Where designed to be soldered at high temperatures, "RoHS" products are suitable for use in specified lead-free processes. TI may reference these types of products as "Pb-Free".

RoHS Exempt: TI defines "RoHS Exempt" to mean products that contain lead but are compliant with EU RoHS pursuant to a specific EU RoHS exemption.

Green: TI defines "Green" to mean the content of Chlorine (Cl) and Bromine (Br) based flame retardants meet JS709B low halogen requirements of <=1000ppm threshold. Antimony trioxide based flame retardants must also meet the <=1000ppm threshold requirement.

- (3) MSL, Peak Temp. - The Moisture Sensitivity Level rating according to the JEDEC industry standard classifications, and peak solder temperature.
- (4) There may be additional marking, which relates to the logo, the lot trace code information, or the environmental category on the device.
- (5) Multiple Device Markings will be inside parentheses. Only one Device Marking contained in parentheses and separated by a "~" will appear on a device. If a line is indented then it is a continuation of the previous line and the two combined represent the entire Device Marking for that device.
- (6) Lead finish/Ball material - Orderable Devices may have multiple material finish options. Finish options are separated by a vertical ruled line. Lead finish/Ball material values may wrap to two lines if the finish value exceeds the maximum column width.

Important Information and Disclaimer:The information provided on this page represents TI's knowledge and belief as of the date that it is provided. TI bases its knowledge and belief on information provided by third parties, and makes no representation or warranty as to the accuracy of such information. Efforts are underway to better integrate information from third parties. TI has taken and continues to take reasonable steps to provide representative and accurate information but may not have conducted destructive testing or chemical analysis on incoming materials and chemicals. TI and TI suppliers consider certain information to be proprietary, and thus CAS numbers and other limited information may not be available for release.

In no event shall TI's liability arising out of such information exceed the total purchase price of the TI part(s) at issue in this document sold by TI to Customer on an annual basis.

TAPE AND REEL INFORMATION

QUADRANT ASSIGNMENTS FOR PIN 1 ORIENTATION IN TAPE

*All dimensions are nominal

Device	Package Type	Package Drawing	Pins	SPQ	Reel Diameter (mm)	Reel Width W1 (mm)	A0 (mm)	B0 (mm)	K0 (mm)	P1 (mm)	W (mm)	Pin1 Quadrant
CDC351DBR	SSOP	DB	24	2000	330.0	16.4	8.2	8.8	2.5	12.0	16.0	Q1
CDC351DWR	SOIC	DW	24	2000	330.0	24.4	10.75	15.7	2.7	12.0	24.0	Q1
CDC351IDBR	SSOP	DB	24	2000	330.0	16.4	8.2	8.8	2.5	12.0	16.0	Q1

TAPE AND REEL BOX DIMENSIONS

*All dimensions are nominal

Device	Package Type	Package Drawing	Pins	SPQ	Length (mm)	Width (mm)	Height (mm)
CDC351DBR	SSOP	DB	24	2000	853.0	449.0	35.0
CDC351DWR	SOIC	DW	24	2000	350.0	350.0	43.0
CDC351IDBR	SSOP	DB	24	2000	853.0	449.0	35.0

TUBE

*All dimensions are nominal

Device	Package Name	Package Type	Pins	SPQ	L (mm)	W (mm)	T (μm)	B (mm)
CDC351DB	DB	SSOP	24	60	530	10.5	4000	4.1
CDC351DW	DW	SOIC	24	25	506.98	12.7	4826	6.6
CDC351DWG4	DW	SOIC	24	25	506.98	12.7	4826	6.6
CDC351IDB	DB	SSOP	24	60	530	10.5	4000	4.1
CDC351IDBG4	DB	SSOP	24	60	530	10.5	4000	4.1
CDC351IDW	DW	SOIC	24	25	506.98	12.7	4826	6.6
CDC351IDWG4	DW	SOIC	24	25	506.98	12.7	4826	6.6

DW (R-PDSO-G24)

PLASTIC SMALL OUTLINE



- NOTES:
- All linear dimensions are in inches (millimeters). Dimensioning and tolerancing per ASME Y14.5M-1994.
 - This drawing is subject to change without notice.
 - Body dimensions do not include mold flash or protrusion not to exceed 0.006 (0,15).
 - Falls within JEDEC MS-013 variation AD.

DB (R-PDSO-G**)

PLASTIC SMALL-OUTLINE

28 PINS SHOWN



- NOTES: A. All linear dimensions are in millimeters.
 B. This drawing is subject to change without notice.
 C. Body dimensions do not include mold flash or protrusion not to exceed 0,15.
 D. Falls within JEDEC MO-150

IMPORTANT NOTICE AND DISCLAIMER

TI PROVIDES TECHNICAL AND RELIABILITY DATA (INCLUDING DATA SHEETS), DESIGN RESOURCES (INCLUDING REFERENCE DESIGNS), APPLICATION OR OTHER DESIGN ADVICE, WEB TOOLS, SAFETY INFORMATION, AND OTHER RESOURCES "AS IS" AND WITH ALL FAULTS, AND DISCLAIMS ALL WARRANTIES, EXPRESS AND IMPLIED, INCLUDING WITHOUT LIMITATION ANY IMPLIED WARRANTIES OF MERCHANTABILITY, FITNESS FOR A PARTICULAR PURPOSE OR NON-INFRINGEMENT OF THIRD PARTY INTELLECTUAL PROPERTY RIGHTS.

These resources are intended for skilled developers designing with TI products. You are solely responsible for (1) selecting the appropriate TI products for your application, (2) designing, validating and testing your application, and (3) ensuring your application meets applicable standards, and any other safety, security, regulatory or other requirements.

These resources are subject to change without notice. TI grants you permission to use these resources only for development of an application that uses the TI products described in the resource. Other reproduction and display of these resources is prohibited. No license is granted to any other TI intellectual property right or to any third party intellectual property right. TI disclaims responsibility for, and you will fully indemnify TI and its representatives against, any claims, damages, costs, losses, and liabilities arising out of your use of these resources.

TI's products are provided subject to [TI's Terms of Sale](#) or other applicable terms available either on ti.com or provided in conjunction with such TI products. TI's provision of these resources does not expand or otherwise alter TI's applicable warranties or warranty disclaimers for TI products.

TI objects to and rejects any additional or different terms you may have proposed.

Mailing Address: Texas Instruments, Post Office Box 655303, Dallas, Texas 75265
Copyright © 2022, Texas Instruments Incorporated