

INA1x9 高侧测量分流监测计

1 特性

- 完整的单极高侧电流测量电路
- 宽电源和共模范围
- INA139: 2.7V 至 40V
- INA169: 2.7V 至 60V
- 独立电源和输入共模电压
- 单电阻增益设定
- 低静态电流: 60 μ A (典型值)
- 5 引脚小外形尺寸晶体管 (SOT)-23 封装

2 应用

- 分流测量:
 - 汽车、电话、计算机
- 便携式和备用电池系统
- 电池充电器
- 电源管理
- 手机
- 精密电流源

3 说明

INA139 和 INA169 均为高侧单极分流监测计。此类器件兼具宽输入共模电压范围、高速和低静态电流特性，并且采用小型 SOT-23 封装，广泛适用于各类应用。

输入共模和电源电压相互独立，INA139 的电压范围为 2.7V 至 40V，INA169 的电压范围为 2.7V 至 60V。静态电流仅为 60 μ A，允许电源连接到电流测量分流器的任一侧，同时误差非常小。

该器件可将一个差分输入电压转换为电流输出。此电流使用外部负载电阻转换回电压，该电阻可设置的增益范围为 1 至 100 以上。尽管该电路专为分流测量而设计，但同时也非常适用于创造性应用中的测量和电平转换。

INA139 和 INA169 均采用 5 引脚 SOT-23 封装，额定温度范围为 -40°C 至 85°C。

器件信息(1)

器件型号	封装	封装尺寸 (标称值)
INA139	SOT-23 (5)	2.90mm x 1.60mm
INA169		

(1) 要了解所有可用封装，请见数据表末尾的可订购产品附录。

典型应用电路

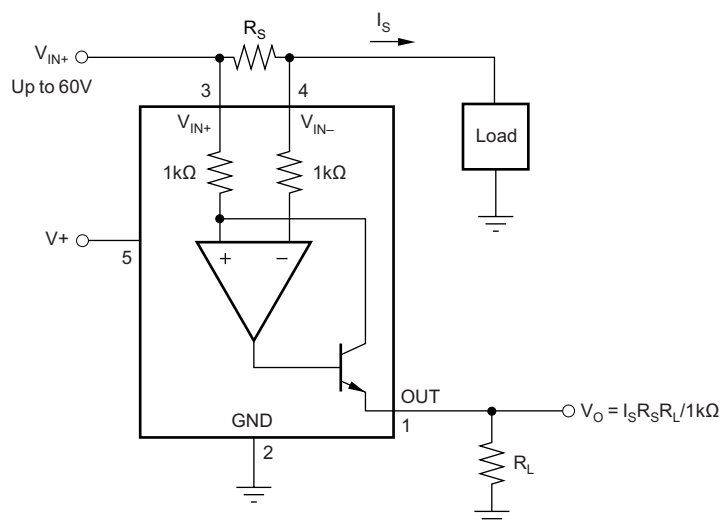

目录

1	特性	1	7.4	Device Functional Modes.....	9
2	应用	1	8	Application and Implementation	10
3	说明	1	8.1	Application Information.....	10
4	修订历史记录	2	8.2	Typical Applications	11
5	Pin Configuration and Functions	3	9	Power Supply Recommendations	16
6	Specifications	4	10	Layout	17
6.1	Absolute Maximum Ratings	4	10.1	Layout Guidelines	17
6.2	ESD Ratings	4	10.2	Layout Example	17
6.3	Recommended Operating Conditions.....	4	11	器件和文档支持	18
6.4	Thermal Information	4	11.1	相关链接	18
6.5	Electrical Characteristics.....	5	11.2	社区资源	18
6.6	Typical Characteristics	6	11.3	商标	18
7	Detailed Description	8	11.4	静电放电警告	18
7.1	Overview	8	11.5	Glossary	18
7.2	Functional Block Diagram	8	12	机械、封装和可订购信息	18
7.3	Feature Description.....	8			

4 修订历史记录

注：之前版本的页码可能与当前版本有所不同。

Changes from Revision D (November 2005) to Revision E

Page

• 已更改 ESD 额定值表，特性描述部分，器件功能模式，应用和实施部分，电源相关建议部分，布局部分，器件和文档支持部分以及机械、封装和可订购信息部分	1
---	----------

5 Pin Configuration and Functions

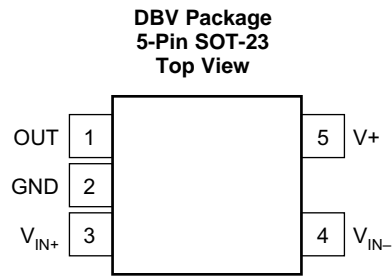

Pin Functions

PIN		I/O	DESCRIPTION
NAME	NO.		
OUT	1	O	Output current
GND	2	—	Ground
V _{IN+}	3	I	Positive input voltage
V _{IN-}	4	I	Negative input voltage
V ₊	5	I	Power supply voltage

6 Specifications

6.1 Absolute Maximum Ratings

over operating free-air temperature range (unless otherwise noted)⁽¹⁾

		MIN	MAX	UNIT	
V+	Supply voltage	INA139	-0.3	60	V
		INA169	-0.3	75	V
V _{IN+} , V _{IN-}	Analog inputs, INA139	Common mode ⁽²⁾	-0.3	60	V
		Differential (V _{IN+}) – (V _{IN-})	-40	2	
	Analog inputs, INA169	Common mode ⁽²⁾	-0.3	75	V
		Differential (V _{IN+}) – (V _{IN-})	-40	2	
Analog output, Out ⁽²⁾		-0.3	40	V	
Input current into any pin			10	mA	
Operating temperature		-55	125	°C	
T _J	Junction temperature		150	°C	
T _{stg}	Storage temperature	-65	125	°C	

- (1) Stresses beyond those listed under *Absolute Maximum Ratings* may cause permanent damage to the device. These are stress ratings only, which do not imply functional operation of the device at these or any other conditions beyond those indicated under *Recommended Operating Conditions*. Exposure to absolute-maximum-rated conditions for extended periods may affect device reliability.
- (2) The input voltage at any pin may exceed the voltage shown if the current at that pin is limited to 10mA.

6.2 ESD Ratings

		VALUE	UNIT
V _(ESD)	Electrostatic discharge	Human body model (HBM), per ANSI/ESDA/JEDEC JS-001, all pins ⁽¹⁾	±1000
		Charged device model (CDM), per JEDEC specification JESD22-C101, all pins ⁽²⁾	±500

- (1) JEDEC document JEP155 states that 500-V HBM allows safe manufacturing with a standard ESD control process.
- (2) JEDEC document JEP157 states that 250-V CDM allows safe manufacturing with a standard ESD control process.

6.3 Recommended Operating Conditions

over operating free-air temperature range (unless otherwise noted)

		MIN	NOM	MAX	UNIT
INA139					
V+		2.7	5	40	V
Common mode voltage		2.7	12	40	V
INA169					
V+		2.7	5	60	V
Common mode voltage		2.7	12	60	V

6.4 Thermal Information

THERMAL METRIC ⁽¹⁾		INA1x9	UNIT
		DBV (SOT-23)	
		5 PINS	
R _{θJA}	Junction-to-ambient thermal resistance	168.3	°C/W
R _{θJC(top)}	Junction-to-case (top) thermal resistance	73.8	°C/W
R _{θJB}	Junction-to-board thermal resistance	28.1	°C/W
ψ _{JT}	Junction-to-top characterization parameter	2.5	°C/W
ψ _{JB}	Junction-to-board characterization parameter	27.6	°C/W

- (1) For more information about traditional and new thermal metrics, see the *Semiconductor and IC Package Thermal Metrics* application report, [SPRA953](http://www.ti.com/lit/zip/Spra953).

6.5 Electrical Characteristics

All other characteristics at $T_A = -40^\circ\text{C}$ to 85°C , $V_+ = 5\text{ V}$, $V_{IN+} = 12\text{ V}$, and $R_{OUT} = 25\text{ k}\Omega$, unless otherwise noted.

PARAMETER	TEST CONDITIONS	INA139NA			INA169NA			UNIT
		MIN	TYP	MAX	MIN	TYP	MAX	
INPUT								
Full-Scale Sense Voltage	$V_{SENSE} = V_{IN+} - V_{IN-}$		100	500		100	500	mV
Common-Mode Input Range		2.7		40	2.7		60	V
Common-Mode Rejection	$V_{IN+} = 2.7\text{ V to }40\text{ V}$, $V_{SENSE} = 50\text{ mV}$ $V_{IN+} = 2.7\text{ V to }60\text{ V}$, $V_{SENSE} = 50\text{ mV}$	100	115					dB
Offset Voltage ⁽¹⁾ RTI					100	120		dB
			± 0.2	± 1		± 0.2	± 1	mV
vs Temperature	T_{MIN} to T_{MAX}		1			1		$\mu\text{V}/^\circ\text{C}$
vs Power Supply, V_+	$V_+ = 2.7\text{ V to }40\text{ V}$, $V_{SENSE} = 50\text{ mV}$		0.5	10				$\mu\text{V}/\text{V}$
	$V_+ = 2.7\text{ V to }60\text{ V}$, $V_{SENSE} = 50\text{ mV}$					0.1	10	
Input Bias Current			10			10		μA
OUTPUT								
Transconductance vs Temperature	$V_{SENSE} = 10\text{ mV} - 150\text{ mV}$ $V_{SENSE} = 10\text{ mV}$,	990	1000	1010	990	1000	1010	$\mu\text{A}/\text{V}$
			10			10		$\text{nA}/^\circ\text{C}$
Nonlinearity Error	$V_{SENSE} = 10\text{ mV to }150\text{ mV}$		$\pm 0.01\%$	$\pm 0.1\%$		$\pm 0.01\%$	$\pm 0.1\%$	
Total Output Error	$V_{SENSE} = 100\text{ mV}$		$\pm 0.5\%$	$\pm 2\%$		$\pm 0.5\%$	$\pm 2\%$	
Output Impedance			1 5			1 5		$\text{G}\Omega$ pF
Voltage Output	Swing to Power Supply, V_+		$(V_+) - 0.9$	$(V_+) - 1.2$		$(V_+) - 0.9$	$(V_+) - 1.2$	V
	Swing to Common Mode, V_{CM}		$V_{CM} - 0.6$	$V_{CM} - 1$		$V_{CM} - 0.6$	$V_{CM} - 1$	V
FREQUENCY RESPONSE								
Bandwidth	$R_{OUT} = 10\text{ k}\Omega$		440			440		kHz
	$R_{OUT} = 20\text{ k}\Omega$		220			220		kHz
Settling Time (0.1%)	5-V Step, $R_{OUT} = 10\text{ k}\Omega$		2.5			2.5		μs
	5-V Step, $R_{OUT} = 20\text{ k}\Omega$		5			5		μs
NOISE								
Output-Current Noise Density			20			20		$\text{pA}/\sqrt{\text{Hz}}$
Total Output-Current Noise	$\text{BW} = 100\text{ kHz}$		7			7		nA RMS
POWER SUPPLY								
Operating Range, V_+		2.7		40	2.7		60	V
Quiescent Current	$V_{SENSE} = 0$, $I_O = 0$		60	125		60	125	μA
TEMPERATURE RANGE								
Specification, T_{MIN} to T_{MAX}		-40		85	-40		85	$^\circ\text{C}$
Operating		-55		125	-55		125	$^\circ\text{C}$
Storage		-65		150	-65		150	$^\circ\text{C}$
Thermal Resistance, θ_{JA}			200			200		$^\circ\text{C}/\text{W}$

(1) Defined as the amount of input voltage, V_{SENSE} , to drive the output to zero.

INA139, INA169

ZHCSFN5E – DECEMBER 2000 – REVISED DECEMBER 2015

www.ti.com.cn

6.6 Typical Characteristics

At $T_A = 25^\circ\text{C}$, $V_+ = 5\text{ V}$, $V_{IN+} = 12\text{ V}$, and $R_L = 125\text{ k}\Omega$, unless otherwise noted.

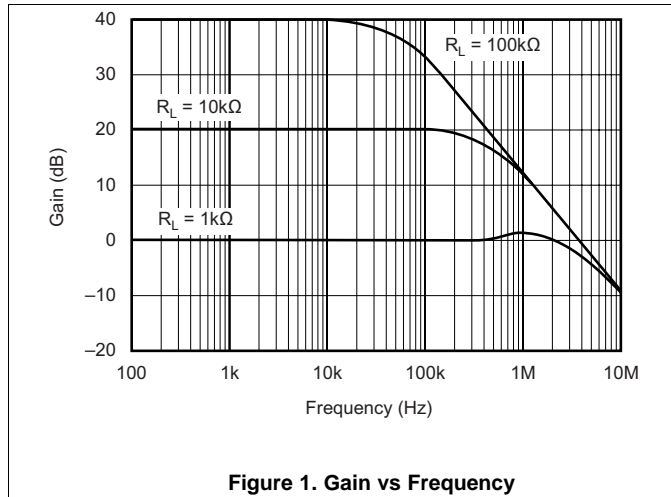

Figure 1. Gain vs Frequency

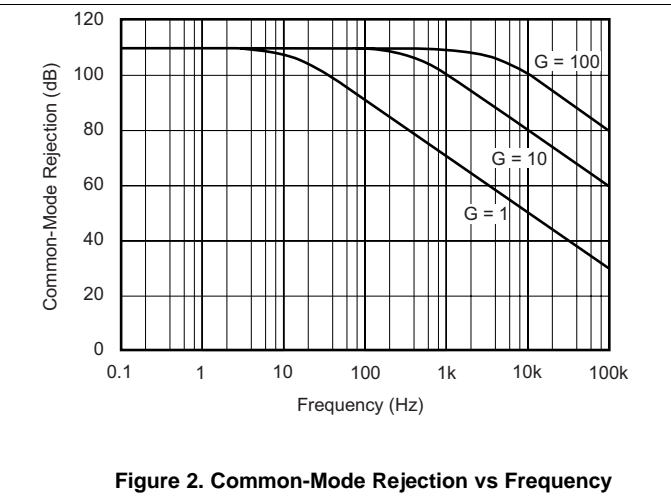

Figure 2. Common-Mode Rejection vs Frequency

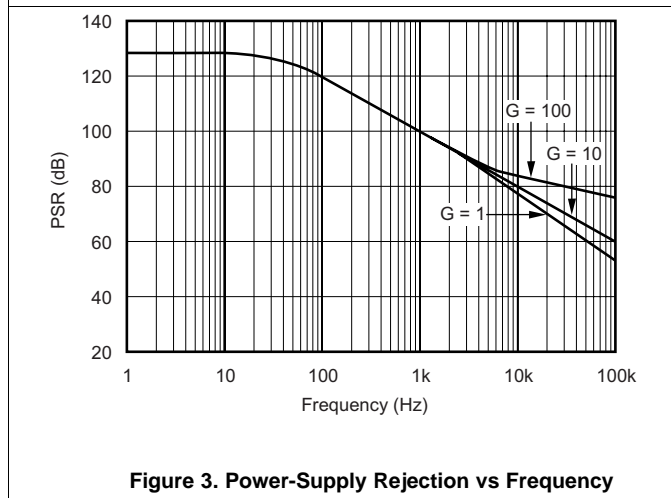

Figure 3. Power-Supply Rejection vs Frequency

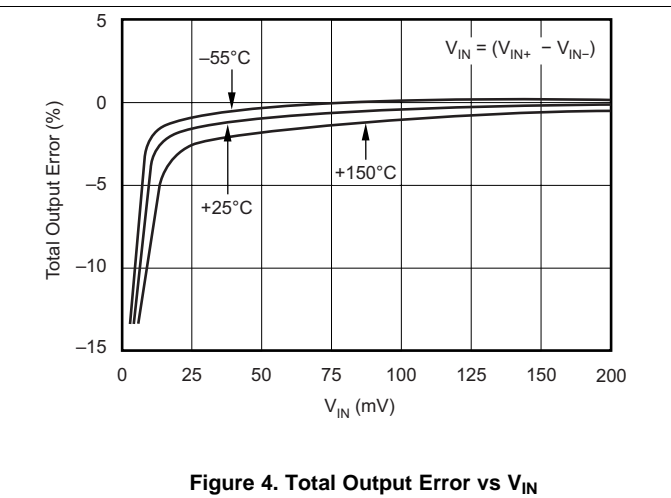

Figure 4. Total Output Error vs V_{IN}

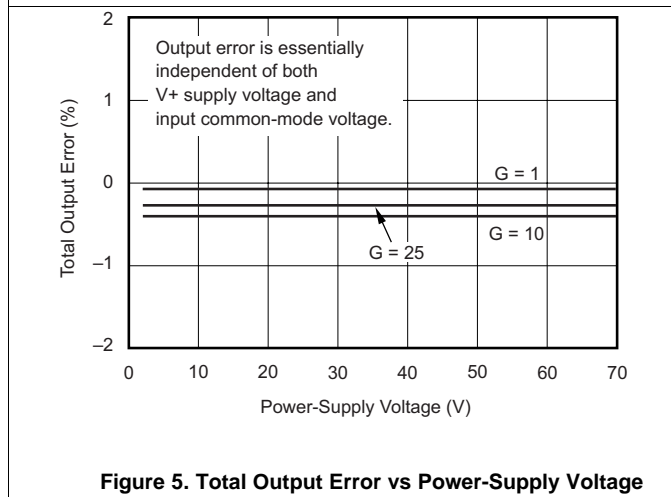

Figure 5. Total Output Error vs Power-Supply Voltage

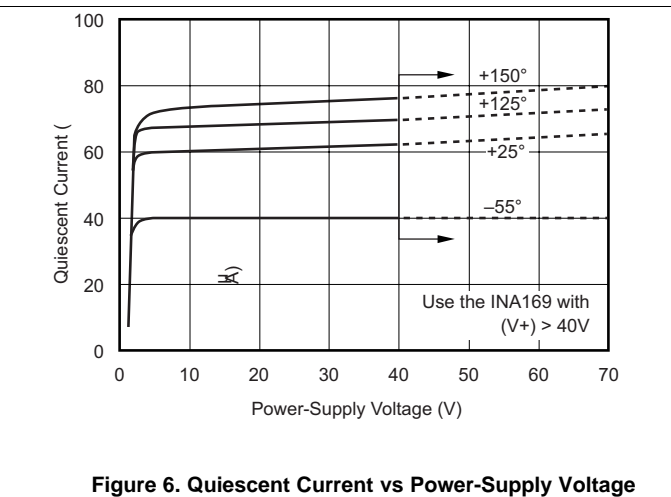
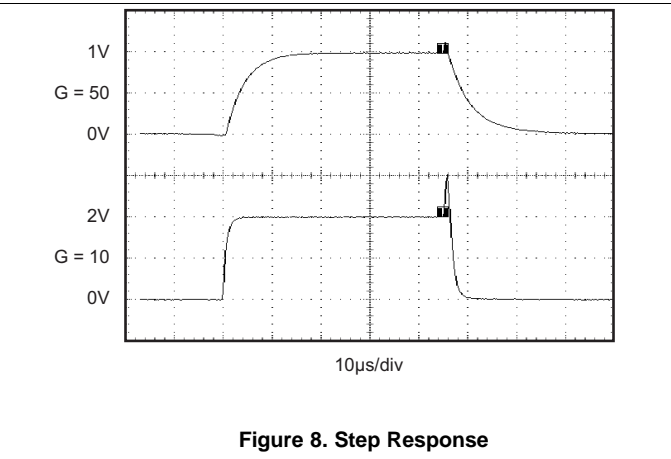
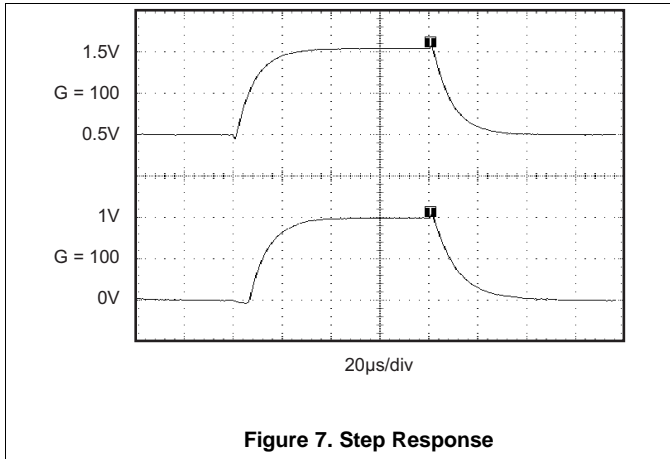

Figure 6. Quiescent Current vs Power-Supply Voltage

Typical Characteristics (continued)

At $T_A = 25^\circ\text{C}$, $V_+ = 5\text{ V}$, $V_{IN+} = 12\text{ V}$, and $R_L = 125\text{ k}\Omega$, unless otherwise noted.



7 Detailed Description

7.1 Overview

The INA139 and INA169 devices are comprised of a high voltage, precision operational amplifier, precision thin film resistors trimmed in production to an absolute tolerance and a low noise output transistor. The INA139 and INA169 devices can be powered from a single power supply and their input voltages can exceed the power supply voltage. The INA139 and INA169 devices are ideal for measuring small differential voltages, such as those generated across a shunt resistor in the presence of large, common-mode voltages. See [Functional Block Diagram](#), which illustrates the functional components within both the INA139 and INA169 devices.

7.2 Functional Block Diagram

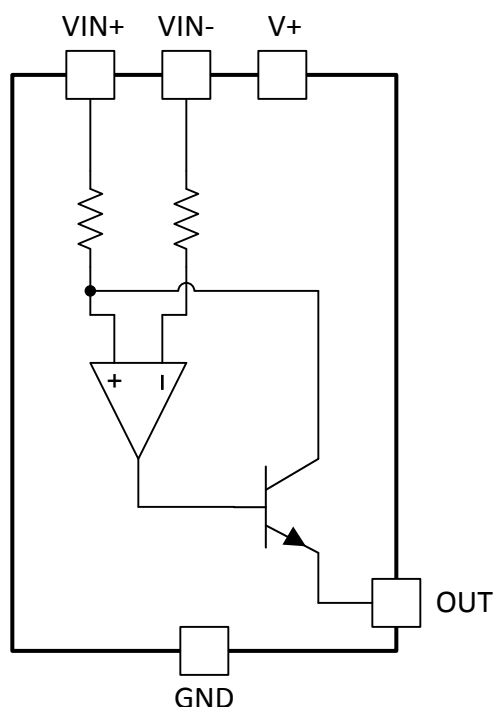

7.3 Feature Description

7.3.1 Output Voltage Range

The output of the INA139 is a current, which is converted to a voltage by the load resistor, R_L . The output current remains accurate within the *compliance voltage range* of the output circuitry. The shunt voltage and the input common-mode and power-supply voltages limit the maximum possible output swing. The maximum output voltage compliance is limited by the lower of [Equation 1](#) and [Equation 2](#).

$$V_{out\ max} = (V+) - 0.7\ V - (V_{IN+} - V_{IN-}) \quad (1)$$

or

$$V_{out\ max} = V_{IN-} - 0.5\ V \quad (2)$$

(whichever is lower)

7.3.2 Bandwidth

Measurement bandwidth is affected by the value of the load resistor, R_L . High gain produced by high values of R_L will yield a narrower measurement bandwidth (see [Typical Characteristics](#)). For widest possible bandwidth, keep the capacitive load on the output to a minimum. Reduction in bandwidth due to capacitive load is shown in the [Typical Characteristics](#).

Feature Description (continued)

If bandwidth limiting (filtering) is desired, a capacitor can be added to the output (see [Figure 12](#)). This will not cause instability.

7.4 Device Functional Modes

For proper operation the INA139 and INA169 devices must operate within their specified limits. Operating either device outside of their specified power supply voltage range or their specified common-mode range will result in unexpected behavior and is not recommended. Additionally operating the output beyond their specified limits with respect to power supply voltage and input common-mode voltage will also produce unexpected results. See [Electrical Characteristics](#) for the device specifications.

8 Application and Implementation

NOTE

Information in the following applications sections is not part of the TI component specification, and TI does not warrant its accuracy or completeness. TI's customers are responsible for determining suitability of components for their purposes. Customers should validate and test their design implementation to confirm system functionality.

8.1 Application Information

8.1.1 Operation

Figure 9 illustrates the basic circuit diagram for both the INA139 and INA169. Load current I_S is drawn from supply V_S through shunt resistor R_S . The voltage drop in shunt resistor V_S is forced across R_{G1} by the internal operational amplifier, causing current to flow into the collector of Q1. The external resistor R_L converts the output current to a voltage, V_{OUT} , at the OUT pin.

The transfer function for the INA139 is given by Equation 3:

$$I_O = g_m(V_{IN+} - V_{IN-}) \tag{3}$$

where $g_m = 1000 \mu A/V$.

In the circuit of Figure 9, the input voltage, $(V_{IN+} - V_{IN-})$, is equal to $I_S \times R_S$ and the output voltage, V_{OUT} , is equal to $I_O \times R_L$. The transconductance, g_m , of the INA139 is $1000 \mu A/V$. The complete transfer function for the current measurement amplifier in this application is given by Equation 4:

$$V_{OUT} = (I_S) (R_S) (1000 \mu A/V) (R_L) \tag{4}$$

The maximum differential input voltage for accurate measurements is 0.5 V, which produces a 500- μA output current. A differential input voltage of up to 2 V will not cause damage. Differential measurements (pins 3 and 4) must be unipolar with a more-positive voltage applied to pin 3. If a more-negative voltage is applied to pin 3, the output current, I_O , is zero, but it will not cause damage.

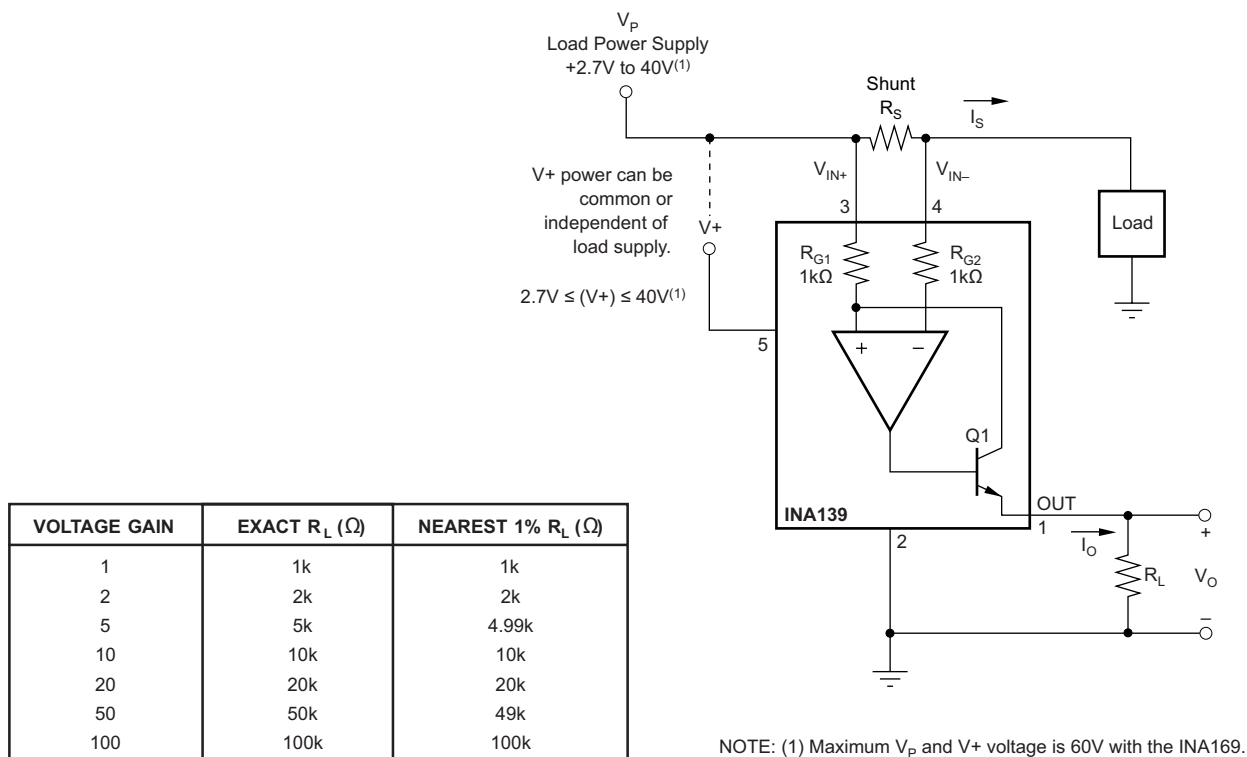

Figure 9. Basic Circuit Connections

8.2 Typical Applications

The INA139 is designed for current shunt measurement circuits, as shown in Figure 9, but its basic function is useful in a wide range of circuitry. A creative engineer will find many unforeseen uses in measurement and level shifting circuits. A few ideas are illustrated in Figure 14 through Figure 18.

8.2.1 Buffering Output to Drive an ADC

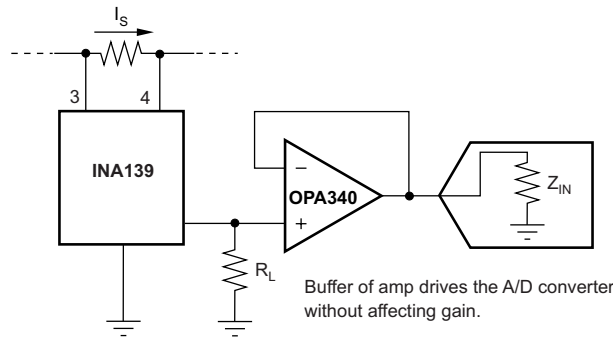

Figure 10. Buffering Output to Drive the A/D Converter

8.2.1.1 Design Requirements

Digitize the output of the INA139 or INA169 devices using a 1-MSPS analog-to-digital converter (ADC).

8.2.1.2 Detailed Design Procedure

8.2.1.2.1 Selecting R_S and R_L

In Figure 9 the value chosen for the shunt resistor, R_S , depends on the application and is a compromise between small-signal accuracy and maximum permissible voltage loss in the measurement line. High values of R_S provide better accuracy at lower currents by minimizing the effects of offset, while low values of R_S minimize voltage loss in the supply line. For most applications, best performance is attained with an R_S value that provides a full-scale shunt voltage of 50 mV to 100 mV; maximum input voltage for accurate measurements is 500 mV.

R_L is chosen to provide the desired full-scale output voltage. The output impedance of the INA139 and INA169 OUT terminal is very high, which permits using values of R_L up to 100 k Ω with excellent accuracy. The input impedance of any additional circuitry at the output must be much higher than the value of R_L to avoid degrading accuracy.

Some Analog-to-Digital converters (ADC) have input impedances that will significantly affect measurement gain. The input impedance of the ADC can be included as part of the effective R_L if its input can be modeled as a resistor to ground. Alternatively, an operational amplifier can be used to buffer the ADC input, as shown in Figure 10. The INA139 and INA169 are current output devices, and as such have an inherently large output impedance. The output currents from the amplifier are converted to an output voltage through the load resistor, R_L , connected from the amplifier output to ground. The ratio of the load resistor value to that of the internal resistor value determines the voltage gain of the system.

In many applications digitizing the output of the INA139 or INA169 devices is required. This is accomplished by connecting the output of the amplifier to an ADC. It is very common for an ADC to have a dynamic input impedance. If the INA139 or INA169 output is connected directly to an ADC input, the input impedance of the ADC is effectively connected in parallel with the gain setting resistor R_L . This parallel impedance combination will affect the gain of the system and the impact on the gain is difficult to estimate accurately. A simple solution that eliminates the paralleling of impedances, simplifying the gain of the circuit is to place a buffer amplifier, such as the OPA340, between the output of the INA139 or INA169 devices and the input to the ADC.

Typical Applications (continued)

Figure 10 illustrates this concept. A low pass filter can be placed between the OPA340 output and the input to the ADC. The filter capacitor is required to provide any instantaneous demand for current required by the input stage of the ADC. The filter resistor is required to isolate the OPA340 output from the filter capacitor to maintain circuit stability. The values for the filter components will vary according to the operational amplifier used for the buffer and the particular ADC selected. More information can be found regarding the design of the low pass filter in the TI Precision Design *16-bit 1-MSPS Data Acquisition Reference Design for Single-Ended Multiplexed Applications*, TIPD173.

Figure 11 shows the expected results when driving an analog-to-digital converter at 1 MSPS with and without buffering the INA139 or INA169 output. Without the buffer, the high impedance of the INA139 or INA169 will react with the input capacitance and sample and hold (S/H) capacitance of the analog-to-digital converter and will not allow the S/H to reach the correct final value before it is reset and the next conversion starts. Adding the buffer amplifier significantly reduces the output impedance driving the S/H and allows for higher conversion rates than can be achieved without adding the buffer.

8.2.1.3 Application Curve

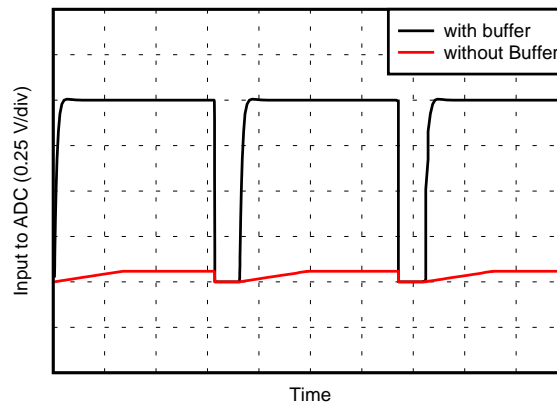

Figure 11. Driving an ADC With and Without a Buffer

8.2.2 Output Filter

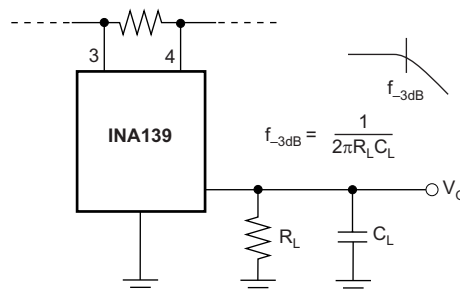

Figure 12. Output Filter

8.2.2.1 Design Requirements

Filter the output of the INA139 or INA169 devices.

8.2.2.2 Detailed Design Procedure

A low-pass filter can be formed at the output of the INA139 or INA169 devices simply by placing a capacitor of the desired value in parallel with the load resistor. First determine the value of the load resistor needed to achieve the desired gain. See the table in Figure 9. Next, determine the capacitor value that will result in the desired cutoff frequency according to the equation shown in Figure 12. Figure 13 illustrates various combinations of gain settings (determined by R_L) and filter capacitors.

Typical Applications (continued)

8.2.2.3 Application Curve

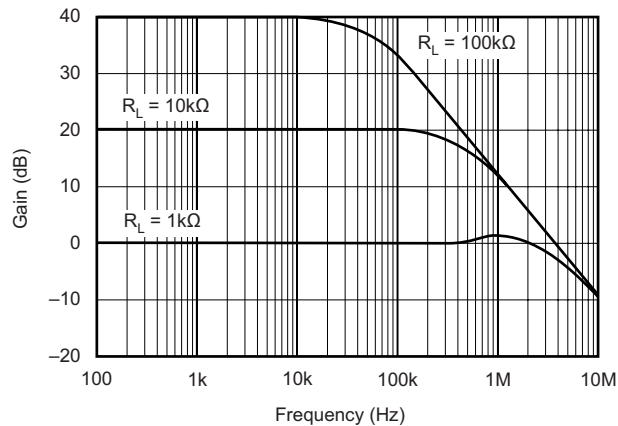

Figure 13. Gain vs Frequency

8.2.3 Offsetting the Output Voltage

For many applications using only a single power supply it may be required to level shift the output voltage away from ground when there is no load current flowing in the shunt resistor. Level shifting the output of the INA139 or INA169 devices is easily accomplished by one of two simple methods shown in Figure 14. The method on the left hand side of Figure 14 illustrates a simple voltage divider method. This method is useful for applications that require the output of the INA138 or INA168 devices to remain centered with respect to the power supply at zero load current through the shunt resistor. Using this method the gain is determined by the parallel combination of R_1 and R_2 while the output offset is determined by the voltage divider ratio R_1 and R_2 . For applications that may require a fixed value of output offset, independent of the power supply voltage, the current source method shown on the right-hand side of Figure 14 is recommended. With this method a REF200 constant current source is used to generate a constant output offset. Using this method the gain is determined by R_L and the offset is determined by the product of the value of the current source and R_L .

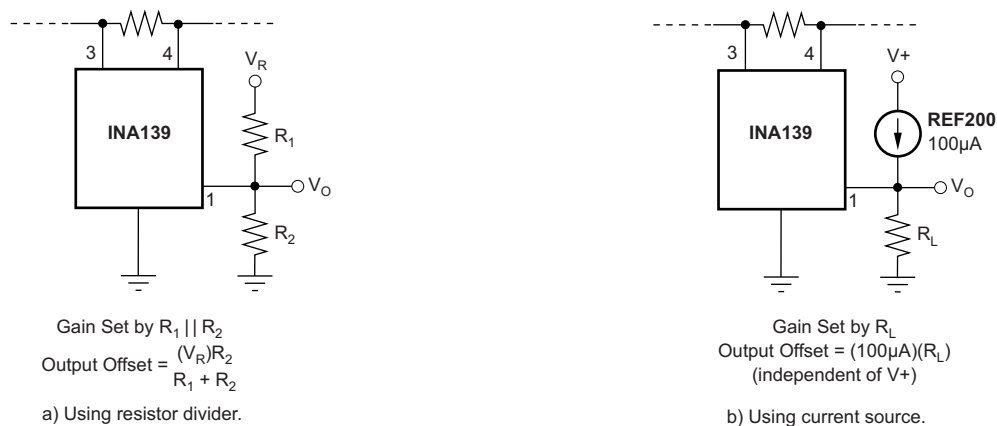

Figure 14. Offsetting the Output Voltage

Typical Applications (continued)

8.2.4 Bipolar Current Measurement

The INA139 or INA169 devices can be configured as shown in [Figure 15](#) in applications where measuring current bi-directionally is required. Two INA devices are required connecting their inputs across the shunt resistor as shown in [Figure 15](#). A comparator, such as the [TLV3201](#), is used to detect the polarity of the load current. The magnitude of the load current is monitored across the resistor connected between ground and the connection labeled *Output*. In this example the 20-k Ω resistor results in a gain of 20 V/V. The 10-k Ω resistors connected in series with the INA139 or INA169 output current are used to develop a voltage across the comparator inputs. Two diodes are required to prevent current flow into the INA139 or INA169 output, as only one device at a time is providing current to the *Output* connection of the circuit. The circuit functionality is illustrated in [Figure 16](#).

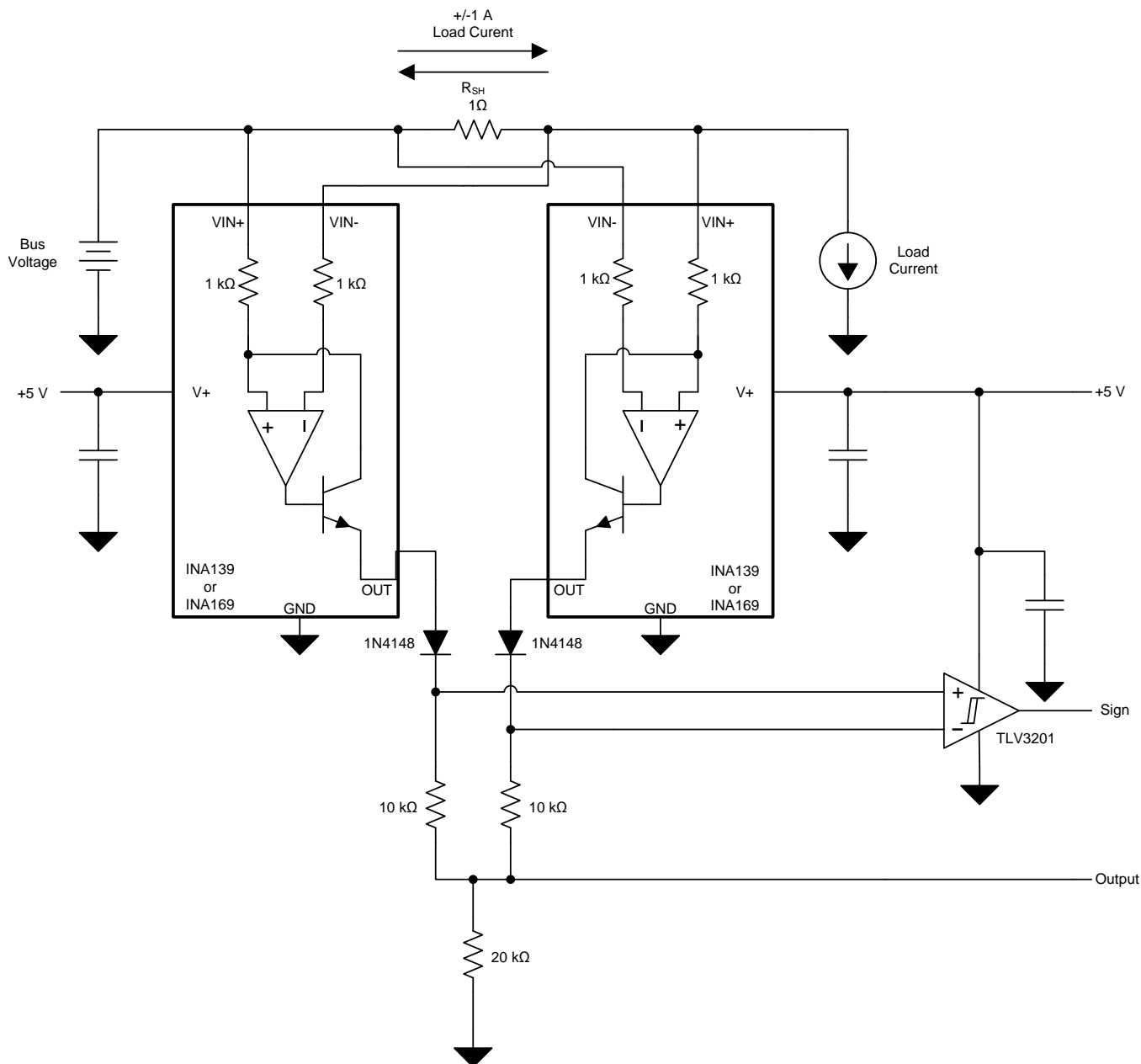

Figure 15. Bipolar Current Measurement

Typical Applications (continued)

8.2.4.1 Application Curve

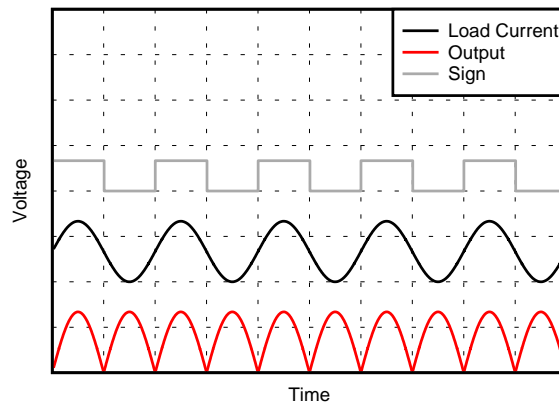

Figure 16. Bipolar Current Measurement Results (Arbitrary Scale)

8.2.5 Bipolar Current Measurement Using a Differential Input of the A/D Converter

The INA139 or INA169 devices can be used with an ADC such as the [ADS7870](#) programmed for differential mode operation. Figure 17 illustrates this configuration. In this configuration, the use of two INAs allows for bi-directional current measurement. Depending upon the polarity of the current, one of the INAs will provide an output voltage while the other output is zero. In this way the ADC will read the polarity of current directly, without the need for additional circuitry.

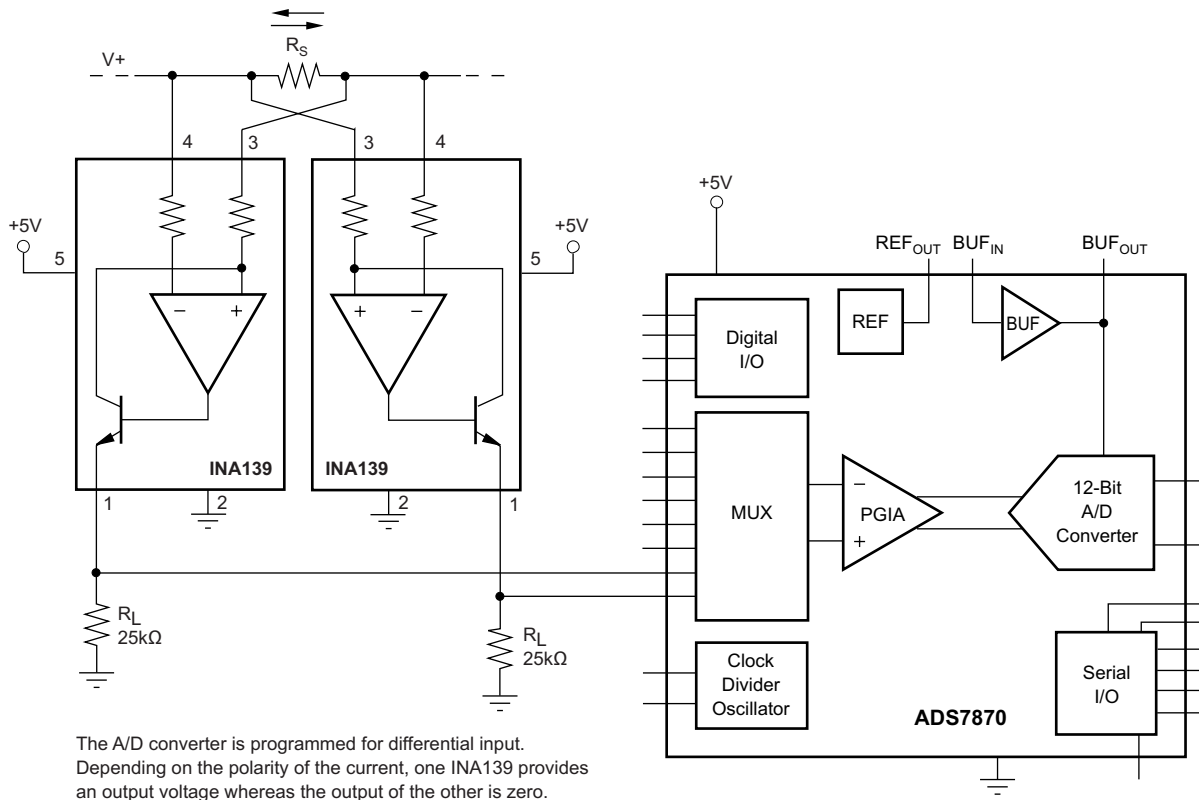

Figure 17. Bipolar Current Measurement Using a Differential Input of the A/D Converter

Typical Applications (continued)

8.2.6 Multiplexed Measurement Using Logic Signal for Power

Multiple loads can be measured as illustrated in [Figure 18](#). In this configuration each INA139 or INA169 device is powered by the Digital I/O from the [ADS7870](#). Multiplexing is achieved by switching on or off each the desired I/O.

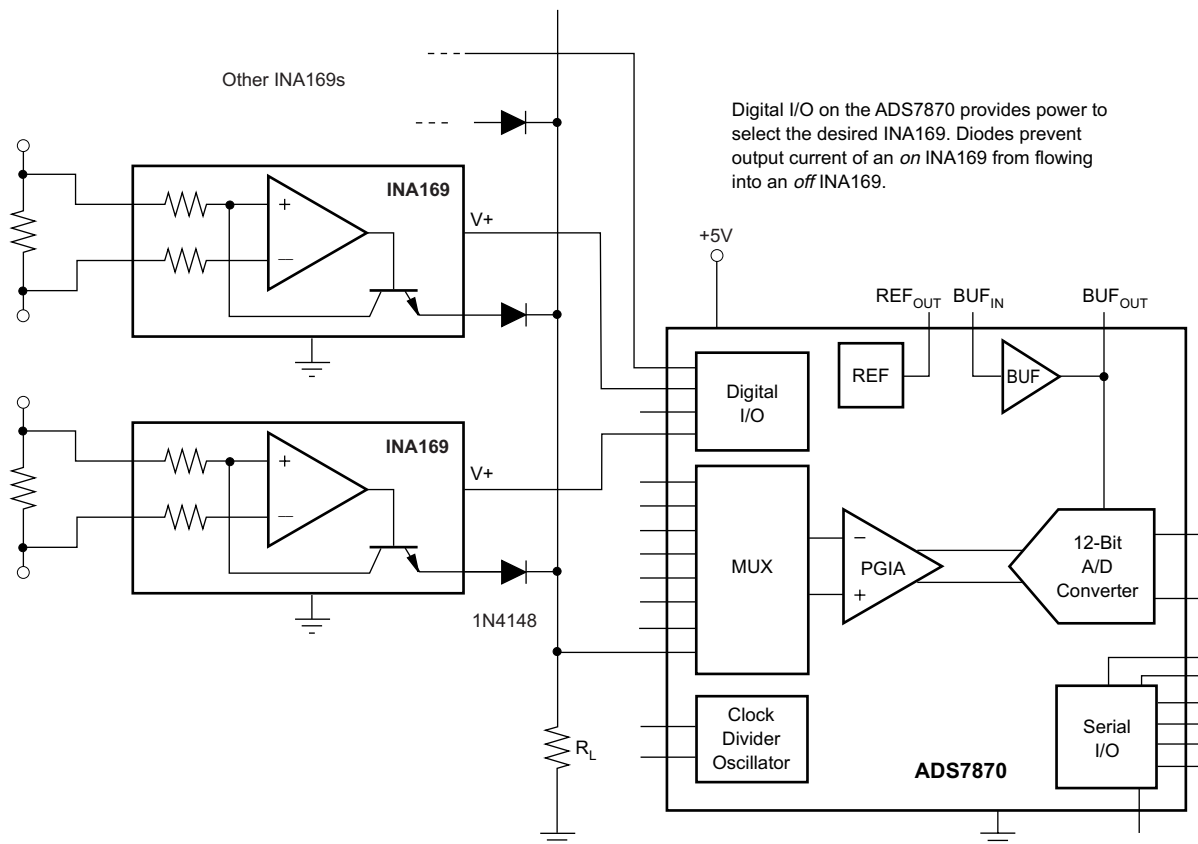

Figure 18. Multiplexed Measurement Using Logic Signal for Power

9 Power Supply Recommendations

The input circuitry of the INA139 can accurately measure beyond its power-supply voltage, $V+$. For example, the $V+$ power supply can be 5 V, whereas the load power supply voltage is up to 40 V (or 60 V with the INA169). However, the output voltage range of the OUT terminal is limited by the lesser of the two voltages (see [Output Voltage Range](#)). TI recommends placing a 0.1- μ F capacitor near the $V+$ pin on the INA139 or INA169. Additional capacitance may be required for applications with noisy supply voltages.

10 Layout

10.1 Layout Guidelines

Figure 19 shows the basic connection of the INA139. The input pins, V_{IN+} and V_{IN-} , must be connected as closely as possible to the shunt resistor to minimize any resistance in series with the shunt resistance. The output resistor, R_L , is shown connected between pin 1 and ground. Best accuracy is achieved with the output voltage measured directly across R_L . This is especially important in high-current systems where load current could flow in the ground connections, affecting the measurement accuracy.

No power-supply bypass capacitors are required for stability of the INA139. However, applications with noisy or high-impedance power supplies may require decoupling capacitors to reject power-supply noise; connect the bypass capacitors close to the device pins.

10.2 Layout Example

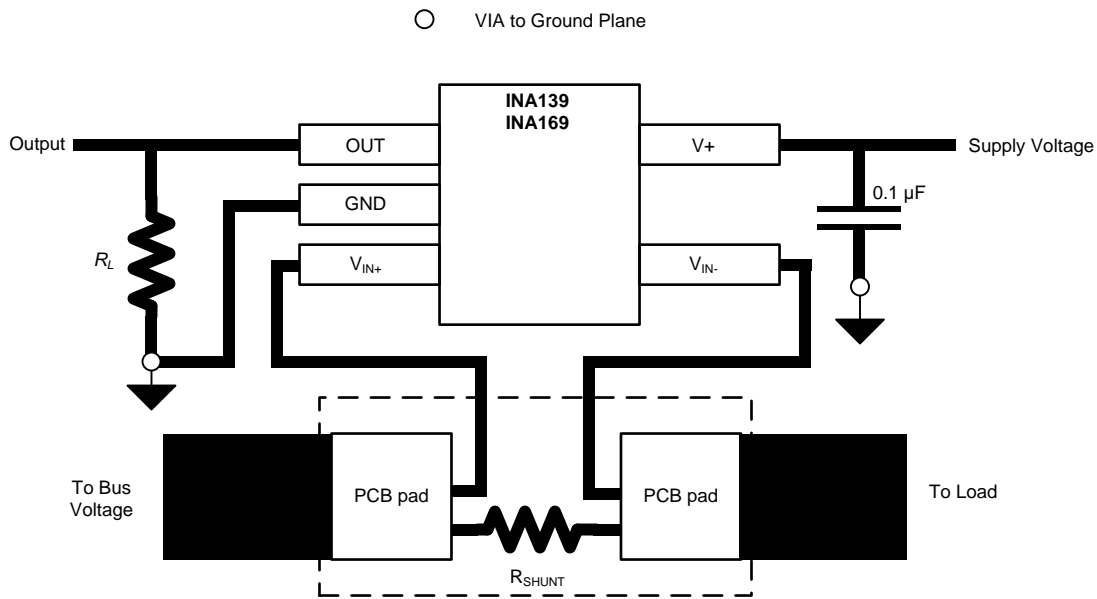

Figure 19. Typical Layout Example

11 器件和文档支持

11.1 相关链接

下面的表格列出了快速访问链接。范围包括技术文档、支持和社区资源、工具和软件，以及样片或购买的快速访问。

表 1. 相关链接

器件	产品文件夹	样片与购买	技术文档	工具与软件	支持与社区
INA139	请单击此处	请单击此处	请单击此处	请单击此处	请单击此处
INA169	请单击此处	请单击此处	请单击此处	请单击此处	请单击此处

11.2 社区资源

The following links connect to TI community resources. Linked contents are provided "AS IS" by the respective contributors. They do not constitute TI specifications and do not necessarily reflect TI's views; see TI's [Terms of Use](#).

TI E2E™ Online Community *TI's Engineer-to-Engineer (E2E) Community*. Created to foster collaboration among engineers. At e2e.ti.com, you can ask questions, share knowledge, explore ideas and help solve problems with fellow engineers.

Design Support *TI's Design Support* Quickly find helpful E2E forums along with design support tools and contact information for technical support.

11.3 商标

E2E is a trademark of Texas Instruments.
All other trademarks are the property of their respective owners.

11.4 静电放电警告



这些装置包含有限的内置 ESD 保护。存储或装卸时，应将导线一起截短或将装置放置于导电泡棉中，以防止 MOS 门极遭受静电损伤。

11.5 Glossary

SLYZ022 — *TI Glossary*.

This glossary lists and explains terms, acronyms, and definitions.

12 机械、封装和可订购信息

以下页中包括机械、封装和可订购信息。这些信息是针对指定器件可提供的最新数据。这些数据会在无通知且不对本文档进行修订的情况下发生改变。欲获得该数据表的浏览器版本，请查阅左侧的导航栏。

PACKAGING INFORMATION

Orderable Device	Status (1)	Package Type	Package Drawing	Pins	Package Qty	Eco Plan (2)	Lead finish/ Ball material (6)	MSL Peak Temp (3)	Op Temp (°C)	Device Marking (4/5)	Samples
INA139NA/250	ACTIVE	SOT-23	DBV	5	250	RoHS & Green	NIPDAU	Level-2-260C-1 YEAR	-40 to 125	E39	Samples
INA139NA/3K	ACTIVE	SOT-23	DBV	5	3000	RoHS & Green	NIPDAU	Level-2-260C-1 YEAR	-40 to 125	E39	Samples
INA169NA/250	ACTIVE	SOT-23	DBV	5	250	RoHS & Green	NIPDAU	Level-2-260C-1 YEAR	-40 to 125	A69	Samples
INA169NA/250G4	ACTIVE	SOT-23	DBV	5	250	RoHS & Green	NIPDAU	Level-2-260C-1 YEAR	-40 to 125	A69	Samples
INA169NA/3K	ACTIVE	SOT-23	DBV	5	3000	RoHS & Green	NIPDAU	Level-2-260C-1 YEAR	-40 to 125	A69	Samples
INA169NA/3KG4	ACTIVE	SOT-23	DBV	5	3000	RoHS & Green	NIPDAU	Level-2-260C-1 YEAR	-40 to 125	A69	Samples

(1) The marketing status values are defined as follows:

ACTIVE: Product device recommended for new designs.

LIFEBUY: TI has announced that the device will be discontinued, and a lifetime-buy period is in effect.

NRND: Not recommended for new designs. Device is in production to support existing customers, but TI does not recommend using this part in a new design.

PREVIEW: Device has been announced but is not in production. Samples may or may not be available.

OBSOLETE: TI has discontinued the production of the device.

(2) **RoHS:** TI defines "RoHS" to mean semiconductor products that are compliant with the current EU RoHS requirements for all 10 RoHS substances, including the requirement that RoHS substance do not exceed 0.1% by weight in homogeneous materials. Where designed to be soldered at high temperatures, "RoHS" products are suitable for use in specified lead-free processes. TI may reference these types of products as "Pb-Free".

RoHS Exempt: TI defines "RoHS Exempt" to mean products that contain lead but are compliant with EU RoHS pursuant to a specific EU RoHS exemption.

Green: TI defines "Green" to mean the content of Chlorine (Cl) and Bromine (Br) based flame retardants meet JS709B low halogen requirements of <=1000ppm threshold. Antimony trioxide based flame retardants must also meet the <=1000ppm threshold requirement.

(3) MSL, Peak Temp. - The Moisture Sensitivity Level rating according to the JEDEC industry standard classifications, and peak solder temperature.

(4) There may be additional marking, which relates to the logo, the lot trace code information, or the environmental category on the device.

(5) Multiple Device Markings will be inside parentheses. Only one Device Marking contained in parentheses and separated by a "~" will appear on a device. If a line is indented then it is a continuation of the previous line and the two combined represent the entire Device Marking for that device.

(6) Lead finish/Ball material - Orderable Devices may have multiple material finish options. Finish options are separated by a vertical ruled line. Lead finish/Ball material values may wrap to two lines if the finish value exceeds the maximum column width.

Important Information and Disclaimer: The information provided on this page represents TI's knowledge and belief as of the date that it is provided. TI bases its knowledge and belief on information provided by third parties, and makes no representation or warranty as to the accuracy of such information. Efforts are underway to better integrate information from third parties. TI has taken and continues to take reasonable steps to provide representative and accurate information but may not have conducted destructive testing or chemical analysis on incoming materials and chemicals. TI and TI suppliers consider certain information to be proprietary, and thus CAS numbers and other limited information may not be available for release.

In no event shall TI's liability arising out of such information exceed the total purchase price of the TI part(s) at issue in this document sold by TI to Customer on an annual basis.

OTHER QUALIFIED VERSIONS OF INA139, INA169 :

- Automotive : [INA139-Q1](#), [INA169-Q1](#)

NOTE: Qualified Version Definitions:

- Automotive - Q100 devices qualified for high-reliability automotive applications targeting zero defects

TAPE AND REEL INFORMATION

QUADRANT ASSIGNMENTS FOR PIN 1 ORIENTATION IN TAPE

*All dimensions are nominal

Device	Package Type	Package Drawing	Pins	SPQ	Reel Diameter (mm)	Reel Width W1 (mm)	A0 (mm)	B0 (mm)	K0 (mm)	P1 (mm)	W (mm)	Pin1 Quadrant
INA139NA/250	SOT-23	DBV	5	250	178.0	9.0	3.3	3.2	1.4	4.0	8.0	Q3
INA139NA/3K	SOT-23	DBV	5	3000	178.0	9.0	3.3	3.2	1.4	4.0	8.0	Q3
INA169NA/250	SOT-23	DBV	5	250	178.0	9.0	3.3	3.2	1.4	4.0	8.0	Q3
INA169NA/3K	SOT-23	DBV	5	3000	178.0	9.0	3.3	3.2	1.4	4.0	8.0	Q3

TAPE AND REEL BOX DIMENSIONS

*All dimensions are nominal

Device	Package Type	Package Drawing	Pins	SPQ	Length (mm)	Width (mm)	Height (mm)
INA139NA/250	SOT-23	DBV	5	250	180.0	180.0	18.0
INA139NA/3K	SOT-23	DBV	5	3000	180.0	180.0	18.0
INA169NA/250	SOT-23	DBV	5	250	180.0	180.0	18.0
INA169NA/3K	SOT-23	DBV	5	3000	180.0	180.0	18.0

EXAMPLE BOARD LAYOUT

DBV0005A

SOT-23 - 1.45 mm max height

SMALL OUTLINE TRANSISTOR

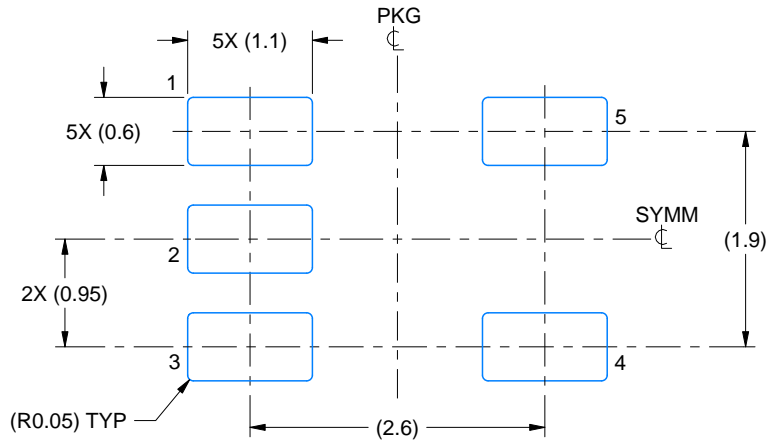

LAND PATTERN EXAMPLE
EXPOSED METAL SHOWN
SCALE:15X

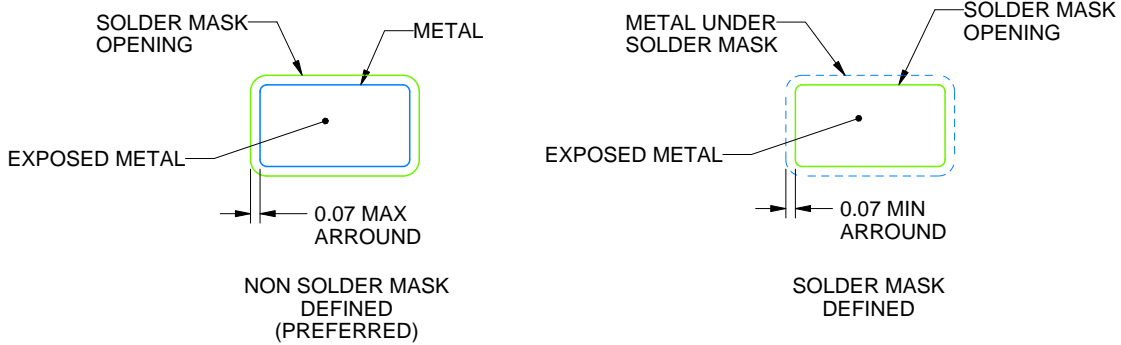

SOLDER MASK DETAILS

4214839/F 06/2021

NOTES: (continued)

- Publication IPC-7351 may have alternate designs.
- Solder mask tolerances between and around signal pads can vary based on board fabrication site.

EXAMPLE STENCIL DESIGN

DBV0005A

SOT-23 - 1.45 mm max height

SMALL OUTLINE TRANSISTOR

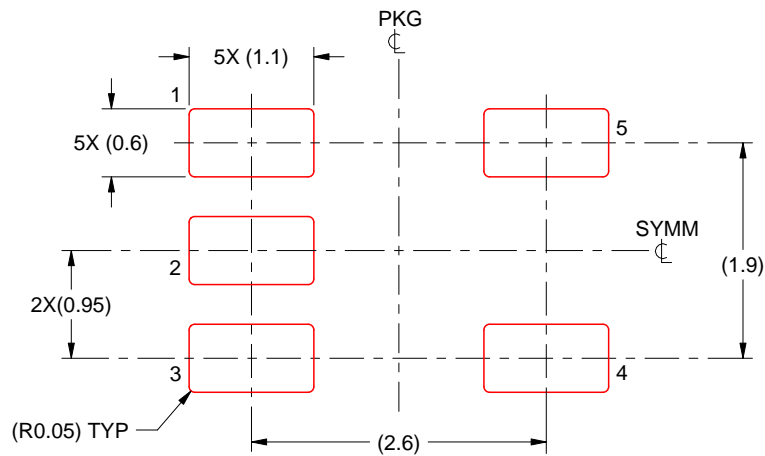

SOLDER PASTE EXAMPLE
BASED ON 0.125 mm THICK STENCIL
SCALE:15X

4214839/F 06/2021

NOTES: (continued)

7. Laser cutting apertures with trapezoidal walls and rounded corners may offer better paste release. IPC-7525 may have alternate design recommendations.
8. Board assembly site may have different recommendations for stencil design.

重要声明和免责声明

TI“按原样”提供技术和可靠性数据（包括数据表）、设计资源（包括参考设计）、应用或其他设计建议、网络工具、安全信息和其他资源，不保证没有瑕疵且不做任何明示或暗示的担保，包括但不限于对适销性、某特定用途方面的适用性或不侵犯任何第三方知识产权的暗示担保。

这些资源可供使用 TI 产品进行设计的熟练开发人员使用。您将自行承担以下全部责任：(1) 针对您的应用选择合适的 TI 产品，(2) 设计、验证并测试您的应用，(3) 确保您的应用满足相应标准以及任何其他功能安全、信息安全、监管或其他要求。

这些资源如有变更，恕不另行通知。TI 授权您仅可将这些资源用于研发本资源所述的 TI 产品的应用。严禁对这些资源进行其他复制或展示。您无权使用任何其他 TI 知识产权或任何第三方知识产权。您应全额赔偿因在这些资源的使用中对 TI 及其代表造成的任何索赔、损害、成本、损失和债务，TI 对此概不负责。

TI 提供的产品受 [TI 的销售条款](#) 或 [ti.com](#) 上其他适用条款/TI 产品随附的其他适用条款的约束。TI 提供这些资源并不会扩展或以其他方式更改 TI 针对 TI 产品发布的适用的担保或担保免责声明。

TI 反对并拒绝您可能提出的任何其他或不同的条款。

邮寄地址：Texas Instruments, Post Office Box 655303, Dallas, Texas 75265
Copyright © 2021，德州仪器 (TI) 公司