

## 5-A, 20-V Integrated FET Hot-Swap Controller

Check for Samples: [TPS2420](#)

### FEATURES

- Integrated 30-mΩ Pass MOSFET
- Up to 20-V Bus Operation
- Programmable Fault Current
- Programmable Hard Current-Limit
- Programmable Fault Timer
- Internal MOSFET Power Limiting Foldback
- Latching and Auto-Retry Operation
- Analog Current Monitor Output
- Powergood Output
- Fault Output Indicator
- 4 mm × 4 mm QFN
- –40°C to 125°C Junction Temperature Range
- UL2367 Recognized - File Number E169910

### APPLICATIONS

- RAID Arrays
- Telecommunications
- Plug-In Circuit Boards
- Disk Drives
- SSDs
- PCIE
- Fan Control

### DESCRIPTION

The TPS2420 device provides highly integrated load protection for applications up to 20-V. The maximum UV turn-on threshold of 2.9 V makes the TPS2420 well suited to standard bus voltages as low as 3.3 V. The TPS2420 device protects loads, minimizes inrush current, and safely shuts down in the event of a fault. The programmable fault current threshold starts the fault timer while allowing the current to pass to the load uninhibited. The programmable current limit threshold sets the maximum current allowed into the load, for both inrush and severe load faults. Both events use the programmable timer which inhibits all current to the load when it expires.

The dual protection thresholds are useful in applications such as disk drives. The start-up and seek currents are typically higher than the nominal current and during this time the load needs a low impedance path to deliver the power. If a failure at the load occurs, the current limit does not allow the current to exceed the programmed threshold. This protects both the load and the integrity of the power supply. The internal MOSFET is protected by power limit circuitry which ensures that the MOSFET remains within its safe operating area (SOA) during all operating states.

The TPS2420 device also allows the system to monitor load currents with no need for a shunt in the power path. The gain of the current monitor can be scaled to the application. Fault and power good outputs are provided for improved system management and sequencing control.

This device can be programmed to either latch-off or retry in the event of a fault. All of this functionality is packed into a 16-pin 4 × 4 mm QFN package.

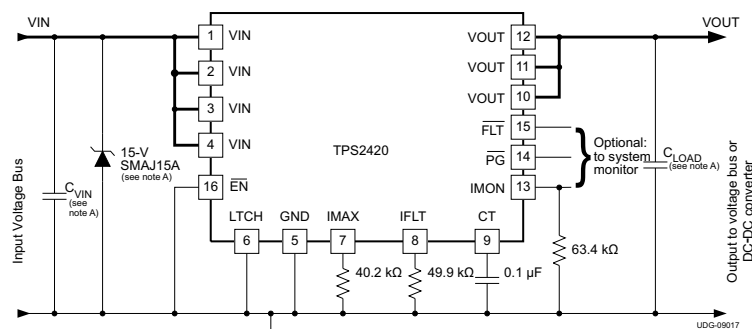

A. Required only in systems with lead and/or load inductance.



Please be aware that an important notice concerning availability, standard warranty, and use in critical applications of Texas Instruments semiconductor products and disclaimers thereto appears at the end of this data sheet.

PowerPad is a trademark of Texas Instruments.

PRODUCTION DATA information is current as of publication date. Products conform to specifications per the terms of the Texas Instruments standard warranty. Production processing does not necessarily include testing of all parameters.

Copyright © 2009–2014, Texas Instruments Incorporated



This integrated circuit can be damaged by ESD. Texas Instruments recommends that all integrated circuits be handled with appropriate precautions. Failure to observe proper handling and installation procedures can cause damage.

ESD damage can range from subtle performance degradation to complete device failure. Precision integrated circuits may be more susceptible to damage because very small parametric changes could cause the device not to meet its published specifications.

## ABSOLUTE MAXIMUM RATINGS<sup>(1)(2)</sup>

over operating free-air temperature range (unless otherwise noted)

	MIN	MAX	UNIT
Voltage range, $V_{IN}$ , $V_{OUT}$	-0.3	25	V
Voltage range, $\overline{FLT}$ , $\overline{PG}$	-0.3	20	
Output sink current, $\overline{FLT}$ , $\overline{PG}$		10	mA
Input voltage range, $\overline{EN}$ LTCH	-0.3	6	V
Input current (LTCH internally clamped to 3 V) LTCH = 0 V,		35	$\mu$ A
Voltage range CT <sup>(3)</sup> , IFLT <sup>(3)</sup> , IMAX, IMON <sup>(3)</sup> , LTCH	-0.3	3	V
ESD rating	Human body model (HBM)	2500	V
	Charged device model (CDM)	400	
Operating junction temperature range, $T_J$	Internally Limited		$^{\circ}$ C
Storage temperature range, $T_{stg}$	-65	150	

(1) Stresses beyond those listed under *absolute maximum ratings* may cause permanent damage to the device. These are stress ratings only, and functional operation of the device at these or any other conditions beyond those indicated under *recommended operating conditions* is not implied. Exposure to absolute-maximum-rated conditions for extended periods may affect device reliability.

(2) All voltage values are with respect to GND.

(3) Do not apply voltage to these pins.

## DISSIPATION RATINGS<sup>(1)</sup>

PACKAGE	$\theta_{JA}$ LOW K <sup>(2)</sup> , $^{\circ}$ C/W	$\theta_{JA}$ HIGH K <sup>(3)</sup> , $^{\circ}$ C/W	$\theta_{JA}$ BEST <sup>(4)</sup> , $^{\circ}$ C/W
RSA	211	55	50

(1) Tested per JEDEC JESD51, natural convection. The definitions of high-k and low-k are per JESD 51-7 and JESD 51-3.

(2) Low-k (2 signal – no plane, 3-inch by 3-inch board, 0.062 inch thick, 1-oz. copper) test board with the pad soldered, and an additional 0.12 inch 2 of top-side copper added to the pad.

(3) High-k is a (2 signal – 2 plane) test board with the pad soldered.

(4) The best case thermal resistance is obtained using the recommendations per [SLMA002](#) (2 signal – 2 plane with the pad connected to the plane).

## RECOMMENDED OPERATING CONDITIONS

PARAMETER	MIN	MAX	UNIT
$V_{IN}$ , $V_{OUT}$ Voltage range	3	20	V
$\overline{EN}$ Voltage range	0	5	V
$\overline{FLT}$ , $\overline{PG}$ Voltage range	0	20	V
$\overline{FLT}$ , $\overline{PG}$ Output sink current	0	1	mA
LTCH Voltage range	0	3	V
CT	0.1	100	$\mu$ F
$T_J$ Junction temperature	-40	125	$^{\circ}$ C

## ELECTRICAL CHARACTERISTICS

over operating free-air temperature range (unless otherwise noted)

PARAMETER		TEST CONDITIONS	MIN	TYP	MAX	UNIT
<b>INPUT SUPPLY (V<sub>IN</sub>)</b>						
V <sub>UVLO</sub>	Undervoltage lockout	V <sub>IN</sub> increasing	2.6	2.85	2.9	V
		Hysteresis		150		mV
Bias current		V <sub>EN</sub> = 2.4 V		25	100	μA
		V <sub>EN</sub> = 0 V		3.9	5	mA
<b>INPUT/OUTPUT</b>						
R <sub>ON</sub>	On-resistance	R <sub>VIN-VOUT</sub> , I <sub>VOUT</sub> < I <sub>IMAX</sub> or I <sub>VOUT</sub> < (I <sub>SET</sub> × 1.25), 1 A ≤ I <sub>VOUT</sub> ≤ 4.5 A		33	50	mΩ
P <sub>LIMIT</sub>	Power limit	V <sub>IN</sub> = 12 V, C <sub>OUT</sub> = 1000 μF EN: 3V → 0 V	3	5	7.5	W
	Reverse diode voltage	V <sub>OUT</sub> > V <sub>IN</sub> , $\overline{\text{EN}} = 5 \text{ V}$ , I <sub>IN</sub> = -1 A		0.77	1	V
<b>FAULT CURRENT (FLT)</b>						
I <sub>FLT</sub>	Fault current threshold	I <sub>VOUT</sub> increasing, I <sub>CT</sub> from sinking to sourcing, pulsed test				A
		R <sub>FLT</sub> = 200 kΩ	0.8	1	1.2	
		R <sub>FLT</sub> = 100 kΩ	1.8	2	2.2	
		R <sub>FLT</sub> = 49.9 kΩ	3.6	4	4.4	
<b>CURRENT-LIMIT (IMAX)</b>						
I <sub>IMAX</sub>	Current-limit program I <sub>VOUT</sub> ↑, V <sub>VIN-VOUT</sub> = 0.3 V, pulsed test	R <sub>IMAX</sub> = 100 kΩ	1.6	2	2.4	A
		R <sub>IMAX</sub> = 66.5 kΩ	2.6	3	3.4	
		R <sub>IMAX</sub> = 40.2 kΩ	4.6	5	5.4	
<b>FAULT TIMER (CT)</b>						
Charge/Discharge current		I <sub>CT</sub> sourcing, V <sub>CT</sub> = 1 V, In current-limit	29	35	41	μA
		I <sub>CT</sub> sinking, V <sub>CT</sub> = 1 V, drive CT to 1 V, measure current	1	1.4	1.8	
Threshold voltage		V <sub>CT</sub> increasing	1.3	1.4	1.5	V
		V <sub>CT</sub> decreasing	0.1	0.16	0.3	
D	ON/OFF fault duty cycle	V <sub>VOUT</sub> = 0 V	2.8%	3.7%	4.6%	
<b>ENABLE (EN)</b>						
Threshold voltage		V <sub>EN</sub> decreasing	0.8	1	1.5	V
		Hysteresis	50	150	250	mV
Input bias current		V <sub>EN</sub> = 2.4 V (sinking)	-1.5	0	0.5	μA
		V <sub>EN</sub> = 0.2 V (sourcing)	2	1	0.5	
Turnon propagation delay		V <sub>IN</sub> = 3.3 V, I <sub>LOAD</sub> = 1 A, V <sub>EN</sub> : 2.4 V → 0.2 V, V <sub>OUT</sub> : ↑ 90% × V <sub>IN</sub>		350	500	μs
Turn-off propagation delay		V <sub>IN</sub> = 3.3 V, I <sub>LOAD</sub> = 1 A, V <sub>EN</sub> : 0.2 V → 2.4V, V <sub>OUT</sub> : ↓ 10% × V <sub>IN</sub>		30	50	

**ELECTRICAL CHARACTERISTICS (continued)**

over operating free-air temperature range (unless otherwise noted)

PARAMETER		TEST CONDITIONS	MIN	TYP	MAX	UNIT
<b>FAULT (IFLT)</b>						
$V_{OL}$	Low-level output voltage	$V_{CT} = 1.8\text{ V}$ , $I_{FLT} = 1\text{ mA}$		0.2	0.4	V
$I_{IFLT}$	Leakage current	$V_{FLT} = 18\text{ V}$			1	$\mu\text{A}$
<b>POWERGOOD (<math>\overline{PG}</math>)</b>						
$V_{\overline{PG}}$	PG threshold	$V_{(VIN-VOUT)}$ decreasing	0.4	0.5	0.65	V
		Hysteresis	0.1	0.25	0.4	
$V_{OL}$	Low-level output voltage	$I_{\overline{PG}} = 1\text{ mA}$		0.2	0.4	
$I_{\overline{PG}}$	Leakage current	$V_{\overline{PG}} = 18\text{ V}$			1	$\mu\text{A}$
<b>CURRENT MONITOR (IMON)</b>						
Ratio $I_{LOAD}/I_{IMON}$		$I_{OUT} = 500\text{ mA}$	30	56	80	A/mA
		$I_{OUT} = 2\text{ A}$	50	61	70	
		$I_{OUT} = 4.5\text{ A}$	56	61	66	
Offset current (sourcing)		$I_{VIN} = 0\text{ A}$	-10	-2	0	$\mu\text{A}$
Clamp voltage			2.6	2.75	2.9	V
<b>LATCH FUNCTION (LTCH)</b>						
Low threshold voltage		Auto retry mode			0.8	V
High threshold		Latch mode	2			
Input bias current		$V_{LTCH} = 3.0\text{ V}$	-1	0.2	1	$\mu\text{A}$
		$V_{LTCH} = 0.2\text{ V}$	-50	-25	0	
<b>THERMAL SHUTDOWN</b>						
Thermal shutdown		Junction temperature increasing		160		$^{\circ}\text{C}$
		Hysteresis		10		

TPS2420 FUNCTIONAL BLOCK DIAGRAM

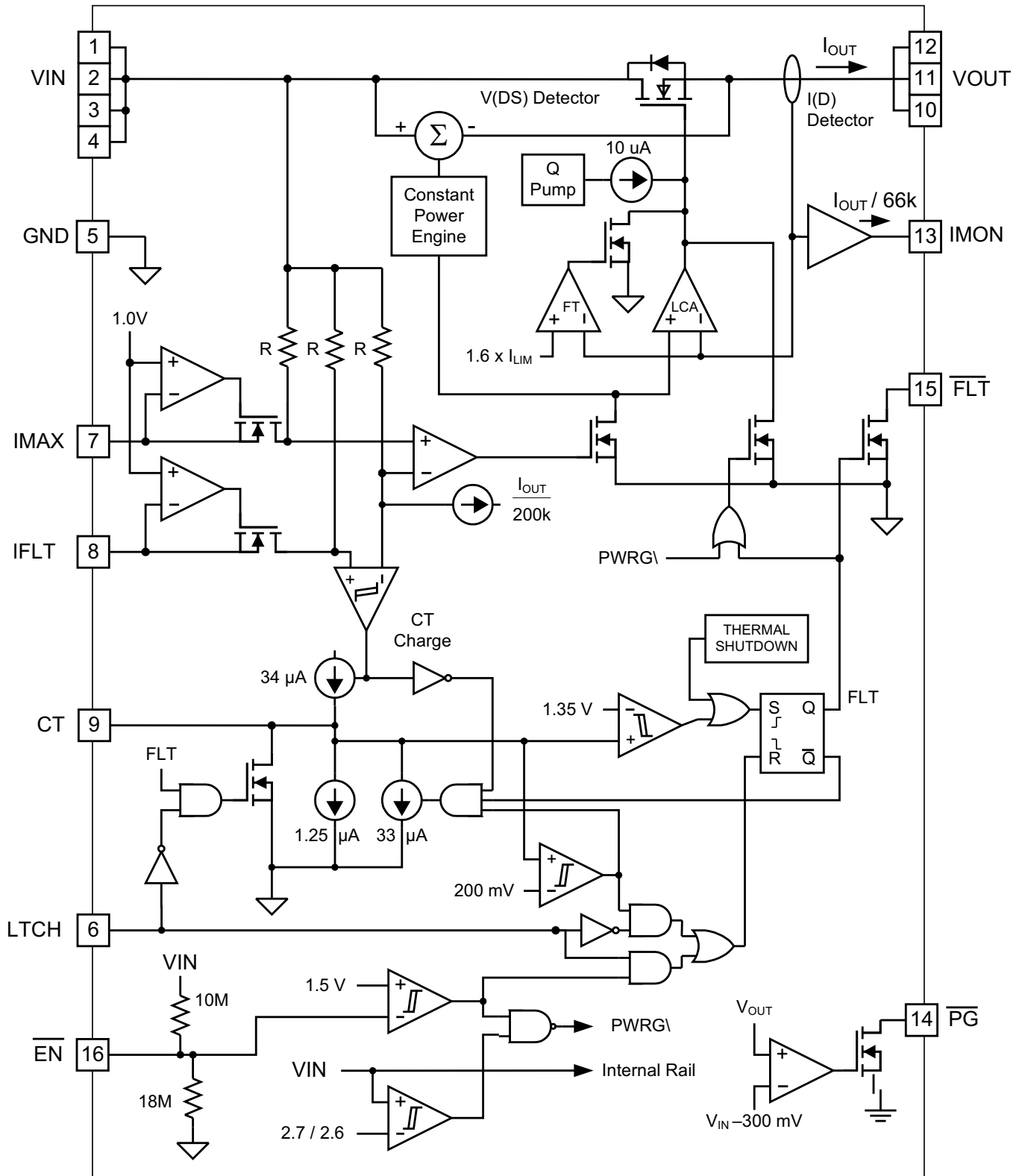

DEVICE INFORMATION

PINOUT DIAGRAM

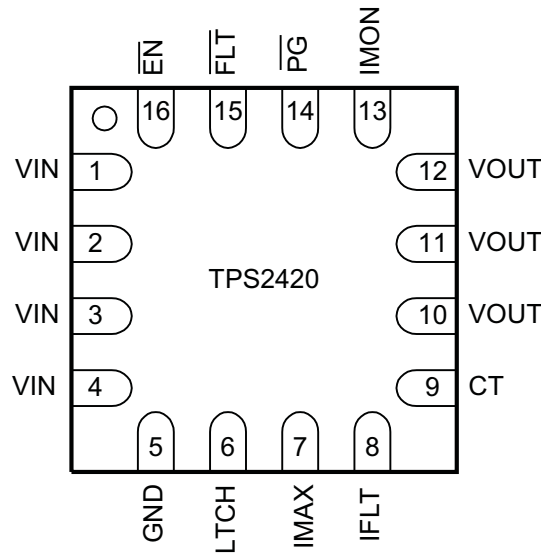

TERMINAL FUNCTIONS

NAME	PIN NO.	I/O	DESCRIPTION
$\overline{EN}$	16	I	Device is enabled when this pin is pulled low.
VIN	1	I	Power in and control supply voltage .
	2		
	3		
	4		
LTCH	6	I	If low, the TPS2420 will attempt to restart after an overcurrent fault. If floating (high) the device will latch off after an overcurrent fault and will not attempt to restart until $\overline{EN}$ or $V_{IN}$ is cycled off and on.
GND	5	—	Ground.
IMAX	7	I	A resistor to ground sets the current-limit level.
IFLT	8	I	A resistor to ground sets the fault current level.
CT	9	I/O	A capacitor to ground sets the fault time.
IMON	13	O	A scaled down current which indicates the current through the device.
VOUT	10	O	Output to the load.
	11		
	12		
$\overline{PG}$	14	O	Power Good low represents the output voltage is within 300 mV of the input voltage.
$\overline{FLT}$	15	O	Fault low indicated the fault time has expired and the FET is switched off.

## PIN DESCRIPTION

**CT:** Connect a capacitor from CT to GND to set the fault time. The fault timer starts when the fault current threshold is exceeded, charging the capacitor with 36  $\mu$ A from GND towards an upper threshold of 1.4 V. If the capacitor reaches the upper threshold, the internal pass MOSFET is turned off. The MOSFET will stay off until EN is cycled if a latching version is used. If an auto-retry version is used, the capacitor will discharge at 5  $\mu$ A to 0.2 V and then re-enable the pass MOSFET. When the device is disabled, CT is pulled to GND through a 100-k $\Omega$  resistor.

The timer period must be chosen long enough to allow the external load capacitance to charge. The fault timer period is selected using the following formula where  $T_{\text{FAULT}}$  is the minimum timer period in seconds and  $C_{\text{CT}}$  is in Farads.

$$C_{\text{CT}} = \frac{T_{\text{FAULT}}}{38.9 \times 10^3} \quad (1)$$

This equation does not account for component tolerances. In autoretry versions, the second and subsequent retry timer periods will be approximately 85% as long as the first retry period.

In autoretry versions, the fault timer discharges the capacitor for a nominal  $T_{\text{SD}}$  in seconds with  $C_{\text{CT}}$  in Farads per the following equation.

$$T_{\text{SD}} = 1.0 \times 10^6 \times C_{\text{CT}} \quad (2)$$

The nominal ratio of on to off times represents about a 3% duty cycle when a hard fault is present on the output of an autoretry version device.

**FLT:** Open-drain output that pulls low on any condition that causes the output to open. These conditions are either an overload with a fault time-out, or a thermal shutdown. FLT becomes operational before UV, when  $V_{\text{IN}}$  is greater than 1 volt.

**GND:** This is the most negative voltage in the circuit and is used as reference for all voltage measurements unless otherwise specified.

**IFLT:** A resistor connected from this pin to ground sets the fault current threshold ( $I_{\text{FAULT}}$ ). Currents between the fault current threshold and the current-limit are permitted to flow unimpeded for the period set by the fault timer programmed on  $C_{\text{T}}$ . This permits loads to draw momentary surges while maintaining the protection provided by a lower average current-limit. IFLT may not be set below 1 A to maintain the Fault Current-Limit threshold accuracy listed in the [RECOMMENDED OPERATING CONDITIONS](#) table. Some parts may not current-limit or fault as expected.

The fault timer implemented by  $C_{\text{T}}$  starts charging  $C_{\text{T}}$  when current through  $V_{\text{IN}}$  exceeds  $I_{\text{FAULT}}$ . If the current doesn't drop below the  $I_{\text{FAULT}}$  level before  $V_{\text{CT}}$  reaches its upper threshold, the output will be shut off. The fault current resistor is set by the following formula where  $I_{\text{FAULT}}$  is in Amperes (A) and  $R_{\text{IFLT}}$  is in ohms ( $\Omega$ ).

$$R_{\text{IFLT}} = \frac{200\text{k}\Omega}{I_{\text{FAULT}}} \quad (3)$$

**IMAX:** A resistor connected from this pin to ground sets  $I_{\text{MAX}}$ . The TPS2420 device limits current to  $I_{\text{MAX}}$ . If the current does not drop below the  $I_{\text{FAULT}}$  level before the timer times out then the output shuts off.  $R_{\text{MAX}}$  is set by the formula:

$$R_{\text{IMAX}} = \frac{201\text{k}\Omega}{I_{\text{MAX}}} \quad (4)$$

$I_{\text{MAX}}$  must be set sufficiently larger than  $I_{\text{FAULT}}$  to ensure that  $I_{\text{MAX}}$  could never be less than  $I_{\text{FAULT}}$ , even after taking tolerances into account.

**EN:** When this pin is pulled low, the device is enabled. The input threshold is hysteretic, allowing the user to program a startup delay with an external RC circuit. EN is pulled to  $V_{\text{IN}}$  by a 10-M $\Omega$  resistor, pulled to GND by 16.8 M $\Omega$  and is clamped to ground by a 7-V Zener diode. Because high impedance pullup/down resistors are used to reduce current draw, any external FET controlling this pin should be low leakage.

**VIN:** Input voltage to the TPS2420 device. The recommended operating voltage range is 3 V to 18 V. All VIN pins should be connected together and to the power source.

**VOUT:** Output connection for the TPS2420 device. When switched on the output voltage will be approximately:

$$V_{OUT} = V_{IN} - 0.04 \times I_{OUT} \quad (5)$$

All V<sub>OUT</sub> pins must be connected together and to the load.

**LTCH:** When pulled low the TPS2420 device attempts to restart after a fault. If left floating or pulled high the TPS2420 device latches off after a fault. This pin is internally clamped at 3 V and is pulled to the internal 3-V supply by diode in series with a 100-kΩ resistor.

**PG:** Active low, Open Drain output, Power Good indicates that there is no fault condition and the output voltage is within 0.5 V of the input voltage. PG becomes operational before UV, whenever V<sub>IN</sub> is greater than 1 V.

**IMON:** This is a scaled analog output of I<sub>VIN</sub>. Select R<sub>IMON</sub> based on the maximum allowed A/D input voltage (V<sub>AD\_FS</sub>) and the desired full-scale current in VIN (I<sub>VIN\_FS</sub>) per the following equation

$$R_{IMON} = \frac{63\text{k}\Omega \times V_{AD\_IN(max)}}{I_{LOAD(max)}} \quad (6)$$

This pin is clamped at 2.5 V to protect A/D converters. It is recommended that I<sub>MON</sub> be ignored until after PG asserts because the I<sub>MON</sub> output is accurate only after V<sub>OUT</sub> > 3 V.

TYPICAL CHARACTERISTICS

CURRENT-LIMIT  
VS  
JUNCTION TEMPERATURE

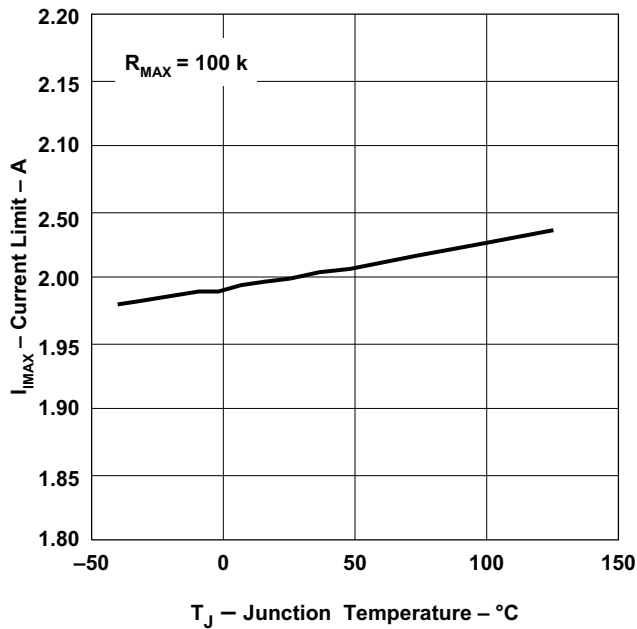

Figure 1.

FAULT CURRENT  
VS  
JUNCTION TEMPERATURE

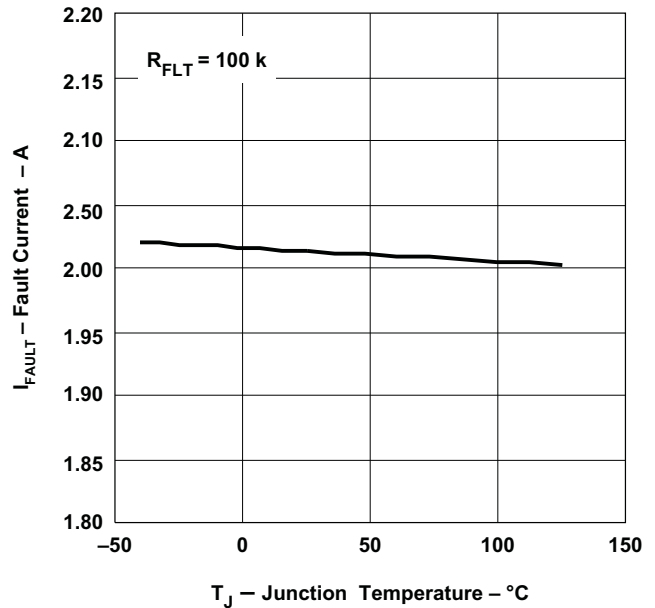

Figure 2.

POWER LIMIT  
VS  
JUNCTION TEMPERATURE

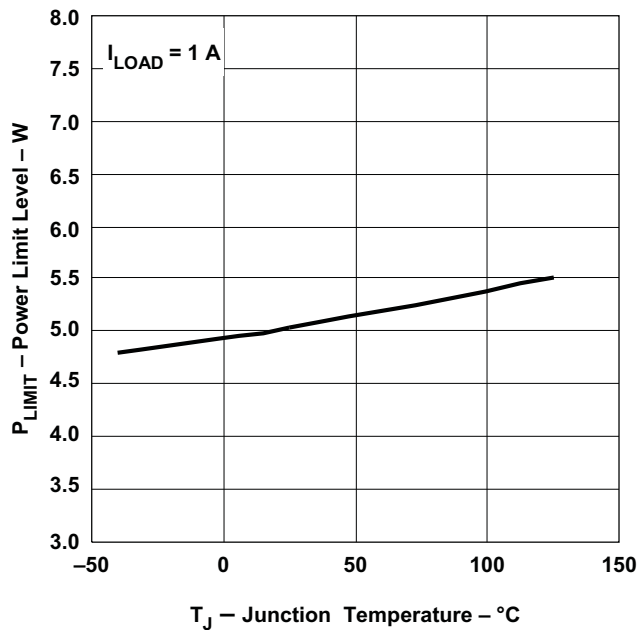

Figure 3.

SUPPLY CURRENT  
VS  
JUNCTION TEMPERATURE

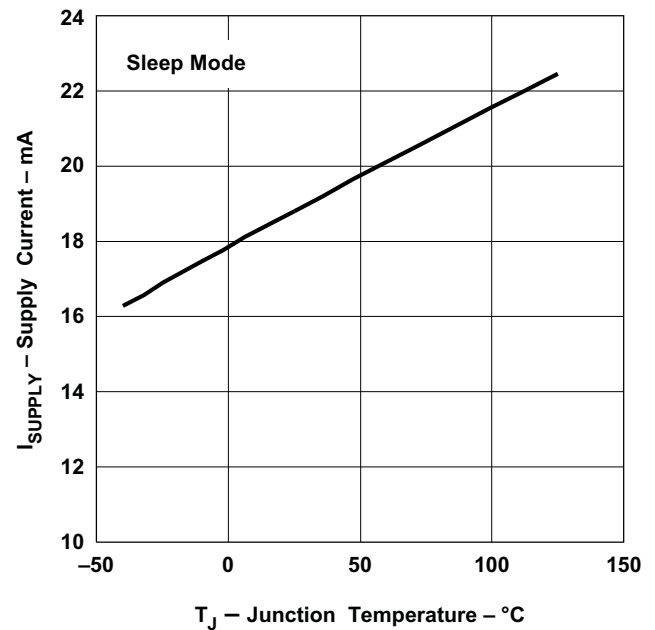

Figure 4.

**TYPICAL CHARACTERISTICS (continued)**

**OUTPUT CURRENT  
VS  
JUNCTION TEMPERATURE**

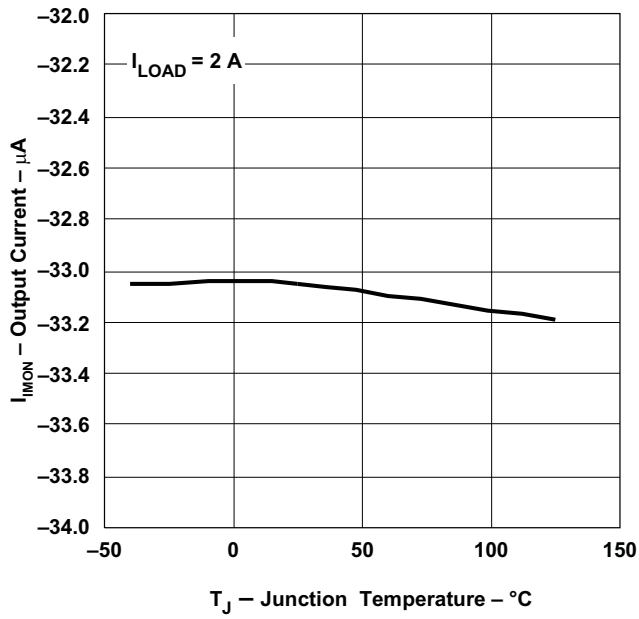

Figure 5.

**FAULT-TIMER THRESHOLD VOLTAGE  
VS  
JUNCTION TEMPERATURE**

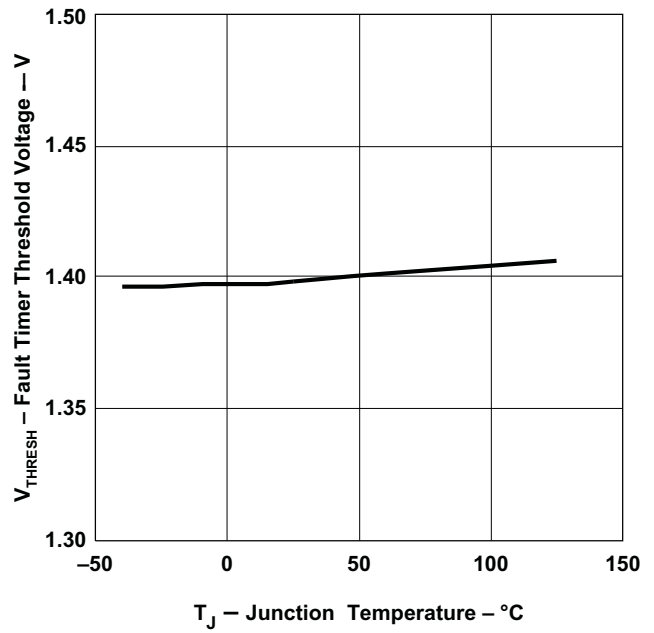

Figure 6.

TYPICAL CHARACTERISTICS

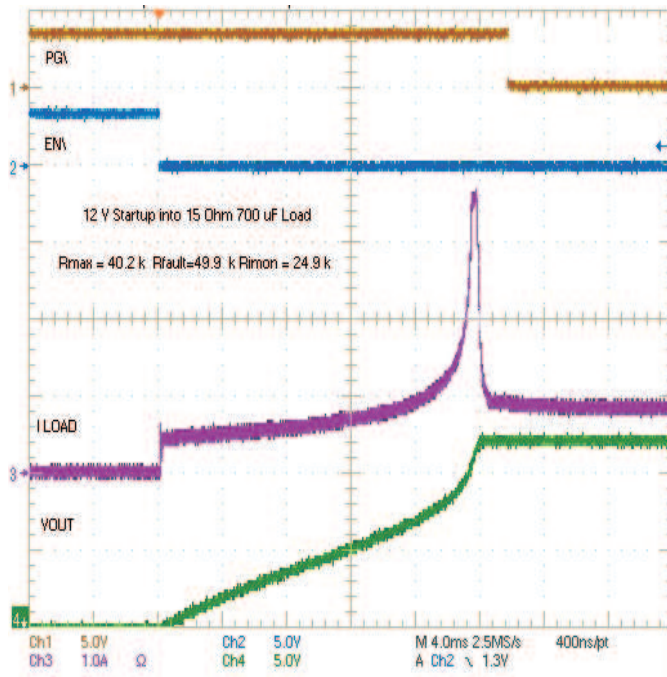

Figure 7. 12-V Startup into 15- $\Omega$ , 700- $\mu$ F Load

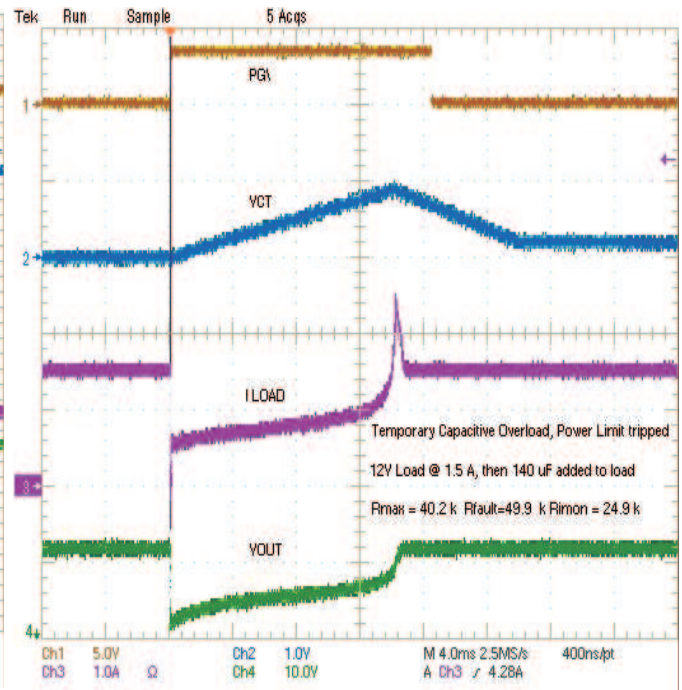

Figure 8. 12-V Input Added to an 8- $\Omega$  Load

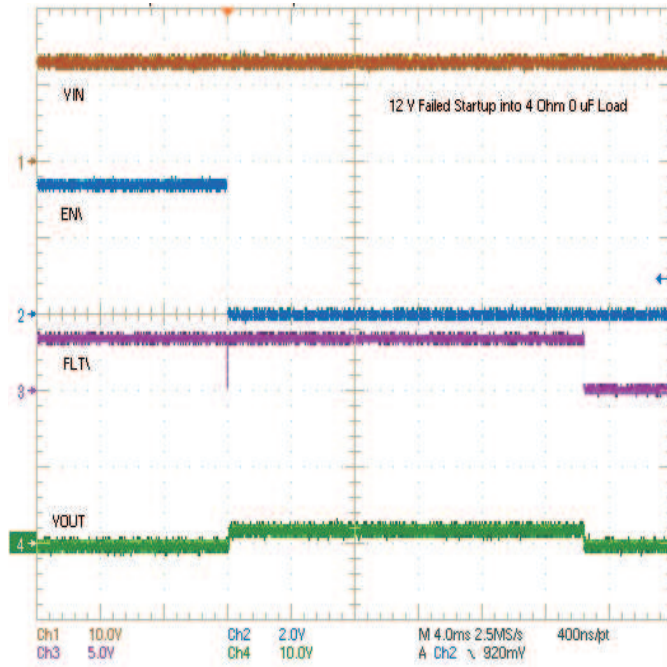

Figure 9. Failed Startup into a 4- $\Omega$  Load

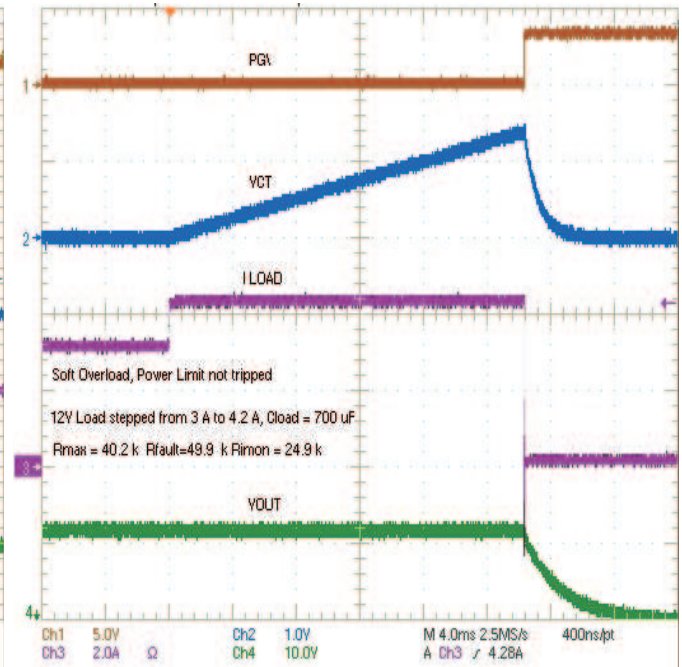

Figure 10. 12-V Soft Overload, 3-A to 4.2-A, Power Limit Not Tripped

TYPICAL CHARACTERISTICS (continued)

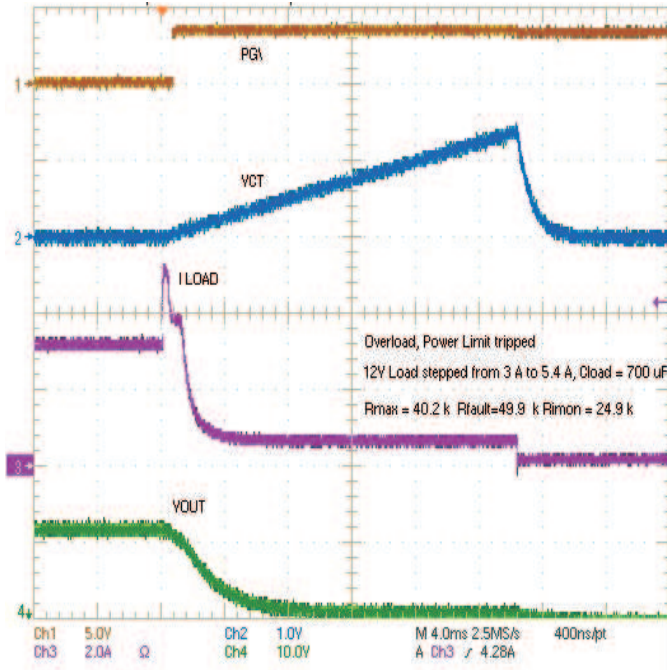

Figure 11. Firm Overload, 3-A to 5.4 A, Power Limit Tripped

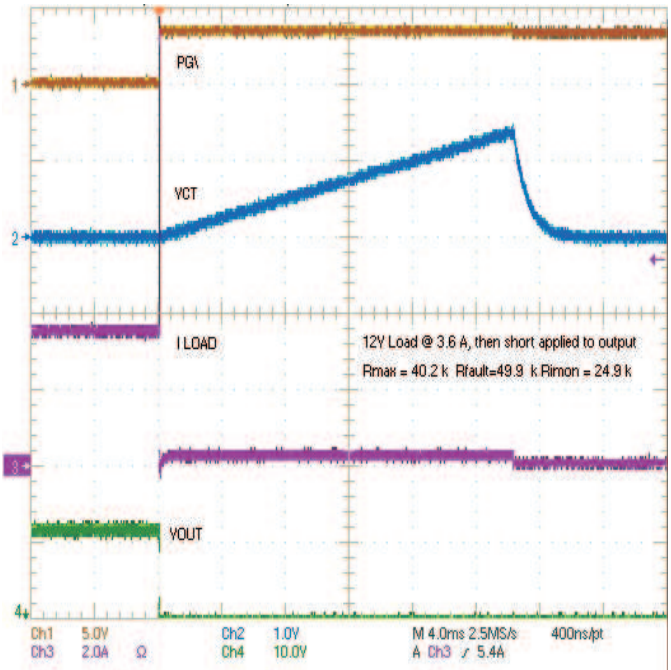

Figure 12. 12-V Hard Overload, 3.6-A Load then Short

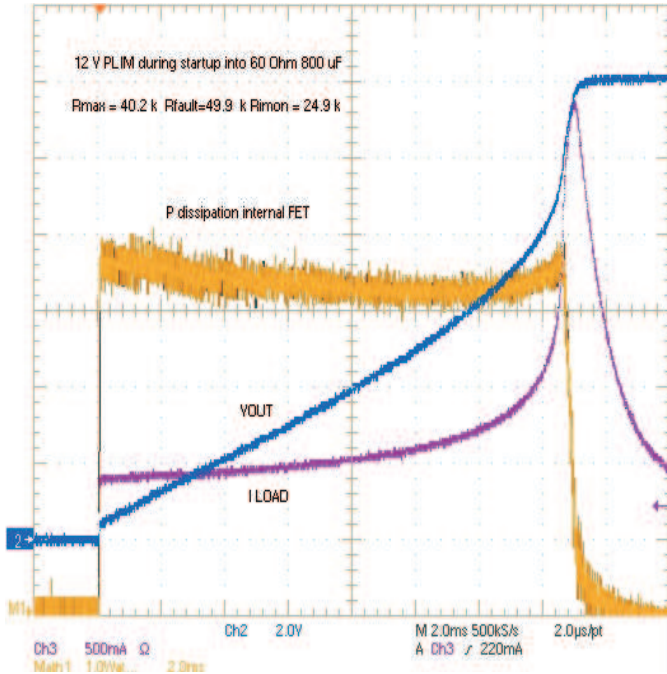

Figure 13. Power Dissipation During 12-V Startup into a 60-Ω, 800-µF Load

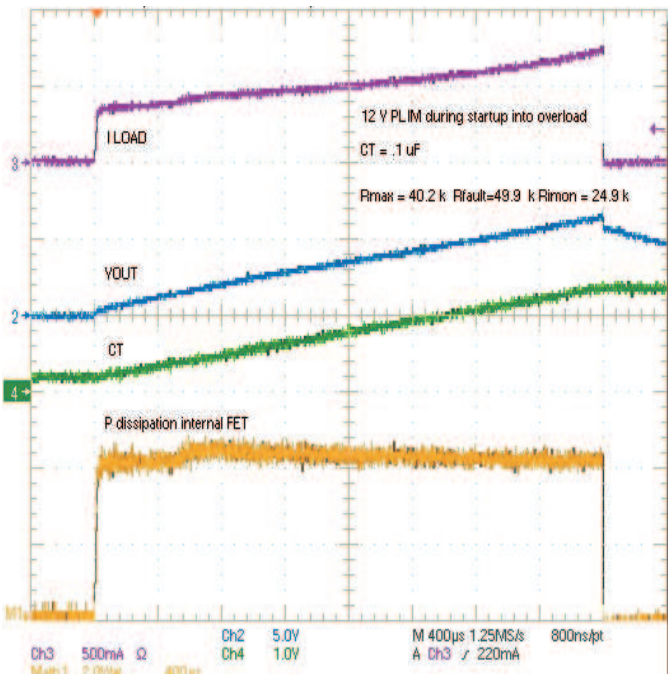

Figure 14. Power Dissipation During 12-V Startup into a 15-Ω, 140-µF Load

TYPICAL CHARACTERISTICS (continued)

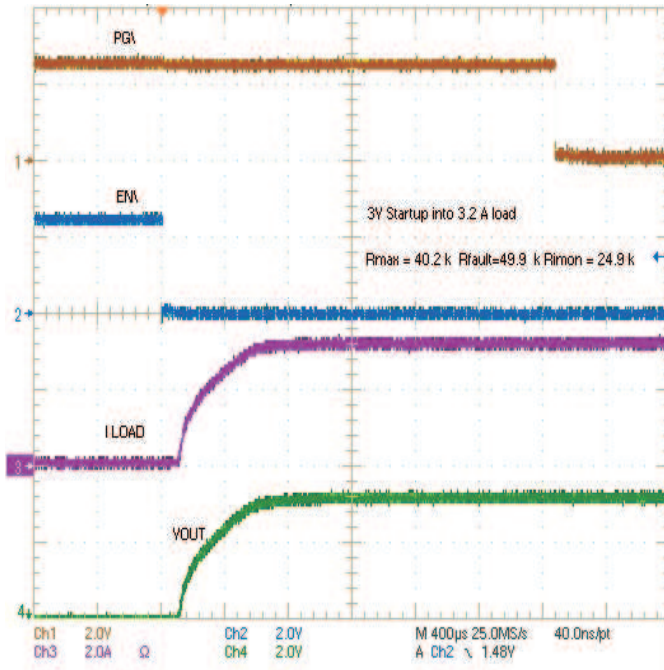

Figure 15. Startup into a 1-Ω Load

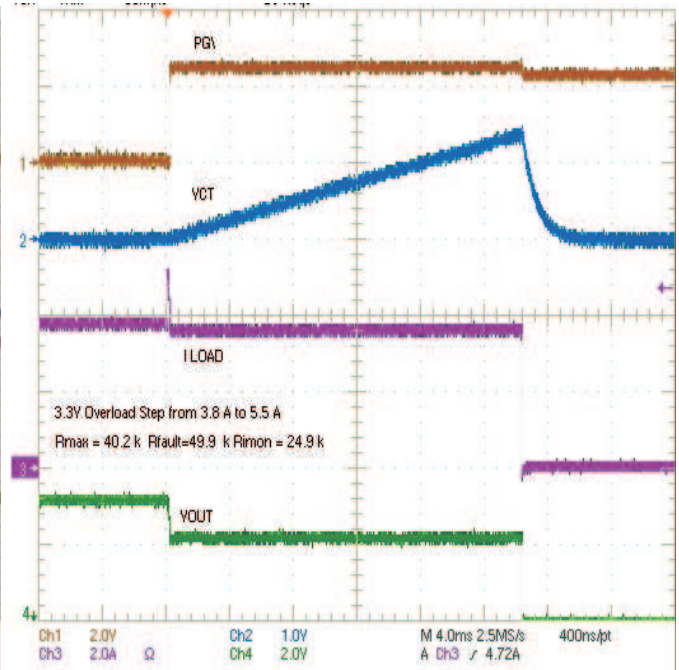

Figure 16. Firm Overload, Load Stepped From 3.8 A to 5.5 A

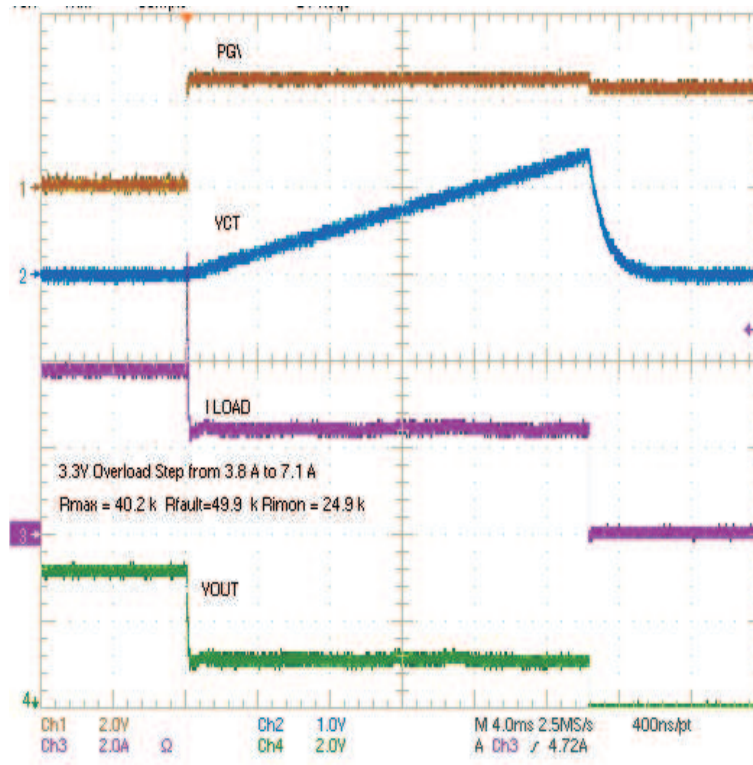

Figure 17. Hard Overload, Load Stepped from 3.8 A to 7.1 A

## APPLICATION INFORMATION

If  $\overline{EN}$  is tied to GND at startup and  $V_{IN}$  does not ramp quickly the TPS2420 device can turn off momentarily then on during startup. This can happen if a capacitive load momentarily pulls down the input voltage below the UV threshold. If necessary, this can be avoided by delaying  $\overline{EN}$  assertion until  $V_{IN}$  is fully up.

### Maximum Load

The power limiting function of the TPS2420 device provides very effective protection for the internal FET. Expectedly, there is a supply voltage dependent maximum load which the device will be able to power up. Loads above this level may cause the device to shut off current before startup is complete. Neglecting any load capacitance, the maximum load ( minimum load resistance ) is calculated using the equation;

$$R_{MIN} = \frac{V_{IN}^2}{12} \quad (7)$$

Adding load capacitance may reduce the maximum load which can be present at startup.

### Transient Protection

The need for transient protection in conjunction with hot-swap controllers should always be considered. When the TPS2420 device interrupts current flow, input inductance generates a positive voltage spike on the input and output inductance generates a negative voltage spike on the output. Such transients can easily exceed twice the supply voltage if steps are not taken to address the issue. Typical methods for addressing transients include;

- Minimizing lead length and inductance into and out of the device
- Voltage Suppressors (TVS) on the input to absorb inductive spikes
- Schottky diode across the output to absorb negative spikes
- A combination of ceramic and electrolytic capacitors on the input and output to absorb energy
- Use PCB GND plane

The following equation estimates the magnitude of these voltage spikes:

$$V_{SPIKE(absolute)} = V_{NOM} + I_{LOAD} \times \sqrt{\frac{L}{C}}$$

where

- $V_{NOM}$  is the nominal supply voltage
- $I_{LOAD}$  is the load current
- $C$  is the capacitance present at the input or output of the TPS2420 device
- $L$  equals the effective inductance seen looking into the source or the load

(8)

Calculating the inductance due to a straight length of wire is shown in [Equation 9](#).

$$L_{straightwire} \approx 0.2 \times L \times \ln\left(\frac{4 \times L}{D} - 0.75\right) \text{ (nH)}$$

where

- $L$  is the length of the wire
- $D$  is diameter of the wire

(9)

Some applications may require the addition of a TVS to prevent transients from exceeding the absolute ratings if sufficient capacitance cannot be included.

## APPLICATION INFORMATION

### Operation

When load current exceeds the user programmed fault limit ( $I_{\text{FAULT}}$ ) during normal operation the fault timer starts. If load current drops below the  $I_{\text{FAULT}}$  threshold before the fault timer expires, normal operation continues. If load current stays above the  $I_{\text{FAULT}}$  threshold the fault timer expires and a fault is declared. When a fault is declared a device operating in latch mode turns off and can be restarted by cycling power or toggling the  $\overline{\text{EN}}$  signal. A device operating in retry mode attempts to turn on at a 3% duty cycle until the fault is cleared. When the  $I_{\text{MAX}}$  limit is reached during a fault the device goes into current-limit and the fault timer keeps running.  $I_{\text{MAX}}$  can be programmed by the user by connecting a resistor from the I<sub>MAX</sub> pin to GND.

### Startup

When power is first applied to a load with discharged capacitors there is a large inrush current. The inrush is controlled by the TPS2420 device by initially entering the power limit mode and turning on the fault timer. See [Figure 19](#). As the charge builds on the capacitor, the current increases to  $I_{\text{MAX}}$ . When the capacitor is fully charged, current output is set by the dc load value, The fault timer is turned off. The FET is then fully enhanced and the power good signal is true.

In order to start properly, the fault timer must be set to exceed the capacitor charge time.

When the load has a resistive component as well as capacitive, the fault time needs to be increased because current to the resistive load is unavailable to charge the capacitor. The startup time for some selected loading is given in [Table 1](#).

[Table 1](#) data was taken with  $I_{\text{FAULT}}$  set to 4 A and  $I_{\text{MAX}}$  set to 5 A. Lower current settings of the TPS2420 device do not have a great influence on the start up timer because of operation at power limit. Load capacitance and dc resistance was selected for a measured start time. The start time is measured from the assertion of the EN pin to the assertion of the PG pin.

**Table 1. Start Time for Input Voltage and Output Loading<sup>(1)</sup>**

INPUT VOLTAGE (V)	LOAD CAPACITANCE (μF)	DC LOAD RESISTANCE (Ω)	START TIME (ms)
5	220	OPEN	2.5
		5	2.7
		12	2.6
	1000	OPEN	4
		5	4
		12	4
12	220	OPEN	4.4
		5	No start
		12	7
	1000	OPEN	14
		5	No start
		12	23

(1)  $I_{\text{FAULT}} = 4 \text{ A}$ ,  $I_{\text{MAX}} = 5 \text{ A}$ .

Some combinations of loading and current-limit settings exceed the 5-W power limit of the internal MOSFET. The output voltage will not turn on regardless of the fault time setting. One way to work with the physical limits that create this problem is to allow the power manager to charge only the capacitive component of the load and use the PG signal to turn on the resistive component. This is common usage in dc-to-dc converters and other electrical equipment with power good inputs.

## Start Up Into a Short

The controller attempts to power on into a short for the duration of the timer. [Figure 20](#) shows a small current resulting from power limiting the internal MOSFET. This happens only once for the latch off mode. For the retry mode, [Figure 24](#) shows this cycle repeating at an interval based on the  $C_T$  time.

## Shutdown Modes

### Hard Overload - Fast Trip

When a hard overload causes the load current to exceed  $1.6 \times I_{MAX}$  the TPS2420 device immediately shuts off current to the load without waiting for the fault timer to expire. After such a shutoff the TPS2420 device enters into startup mode and attempts to apply power to the load.

If the hard overload is caused by a current transient, then a normal startup can be expected with a low probability of disruption to the load, assuming there is sufficient load capacitance to hold up the load during the fractions of a millisecond that make up the fast trip/restart cycle.

If the hard overload is caused by a real, continuous failure then the TPS2420 device goes into current-limit during the attempt at restart. The timer starts and eventually runs out, shutting off current to the load. See the fast trip [Figure 22](#) and [Figure 23](#). When the hard overload occurs the current is turned off, the  $\overline{PG}$  pin becomes false, and the  $\overline{FLT}$  pin stays false. The  $\overline{FLT}$  pin becomes true only when the fault timer times out.

### Overcurrent Shutdown

Overcurrent shutdown occurs when the output current exceeds  $I_{MAX}$  for the duration of the fault timer. Overcurrent shutdown is the circuit breaker type protection of equipment. [Figure 23](#) shows the step rise in output current. The increased current is on for the duration of the timer. At conclusion of the timer, the output is turned off.

## Design Example

The TPS2420 Design shown in [Figure 25](#) supports 12 V to operate a hot plugged disk drive.

The 12 V specification for a disk drive is approximately 1-A operating current and 2-A typical spin-up. Selecting a 2.5 A setting for  $I_{FAULT}$  would allow some margin for the operating current and satisfy the start current requirements.

Calculate  $R_{RFLT}$  using equation [Equation 10](#) or select it using [Table 2](#).

$$R_{IFLT} = \frac{200k\Omega}{I_{FAULT}} \times \frac{200,000}{2.5} = 80 \text{ (k}\Omega\text{)} \quad (10)$$

The  $I_{MAX}$  setting, 3.5 A, is set by  $R_{RMAX}$  in [Equation 11](#).

$$R_{IMAX} = \frac{201k\Omega}{I_{IMAX}} \times \frac{201,000}{3.5} = 57.4 \text{ (k}\Omega\text{)} \quad (11)$$

Because  $I_{\text{FAULT}}$  satisfies the spin up current, the timer can be set for the additional loading of charging the capacitor. Estimate approximately 20 ms. Use either [Equation 12](#) or [Table 2](#) to estimate the capacitance.

$$C_{\text{CT}} = \frac{T_{\text{FAULT}}}{38.9 \times 10^3} = 20 \times \frac{10^{-3}}{38.9} \times 10^3 = 0.514 \times 10^{-6} \quad (12)$$

For a scaled analog readback of the current from  $V_{\text{IN}}$ , set the  $I_{\text{MON}}$  resistor. In [Equation 13](#), the  $V_{\text{AD\_INMAX}}$  is the desired full scale A/D converter voltage. The largest value of  $V_{\text{AD\_INMAX}}$  2.5 V.  $I_{\text{LOADMAX}}$  is the full scale current, 2.5 A.

$$R_{\text{IMON}} = \frac{(63,000 \times V_{\text{AD\_IN(max)}})}{I_{\text{LOAD(max)}}} = \frac{(63,000 \times 2.5)}{2.5} = 63 \text{ (k}\Omega\text{)} \quad (13)$$

The read-back voltage at the IMON pin,  $V_{\text{IMON}}$ , indicates the instantaneous current output. Using [Equation 14](#) again, determine the current output for example, a 1.8-V  $V_{\text{IMON}}$ . Substitute  $V_{\text{IMON}}$  for  $V_{\text{AD\_INMAX}}$  and  $I_{\text{LOAD}}$  for  $I_{\text{LOADMAX}}$  and solve for  $I_{\text{LOAD}}$ , ([Equation 14](#)).

$$I_{\text{LOAD}} = \frac{(63,000 \times V_{\text{IMON}})}{R_{\text{IMON}}} = \frac{(63,000 \times 1.8)}{62,500} = 1.81 \text{ (A)} \quad (14)$$

## Layout

### Support Components

Locate all TPS2420 support components,  $R_{\text{SET}}$ ,  $C_{\text{T}}$ , and others. or any input or output voltage clamps, close to their connection pin. Connect the other end of the component to the inner layer GND without trace length.

### PowerPad™

When properly mounted the PowerPad package provides significantly greater cooling ability than an ordinary package. To operate at rated power the Power Pad must be soldered directly to the PC board GND plane directly under the device. The PowerPad is at GND potential and can be connected using multiple vias to inner layer GND. Other planes, such as the bottom side of the circuit board can be used to increase heat sinking in higher current applications.

Refer to Technical Briefs: *PowerPAD™ Thermally Enhanced Package* (TI Literature Number [SLMA002](#)) and *PowerPAD™ Made Easy* (TI Literature Number [SLMA004](#)) for more information on using this PowerPad™ package. These documents are available at [www.ti.com](http://www.ti.com) (Search by Keyword).

**APPLICATION PLOTS**

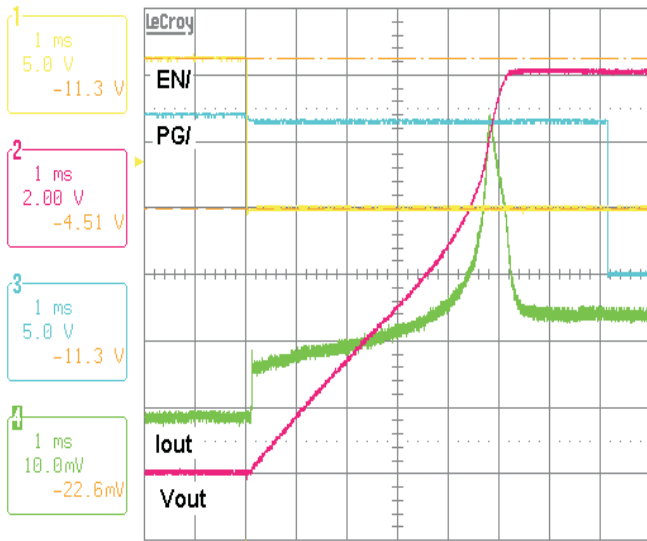

Figure 18. Start Up Into an RC Load ( $\overline{PG}$ )

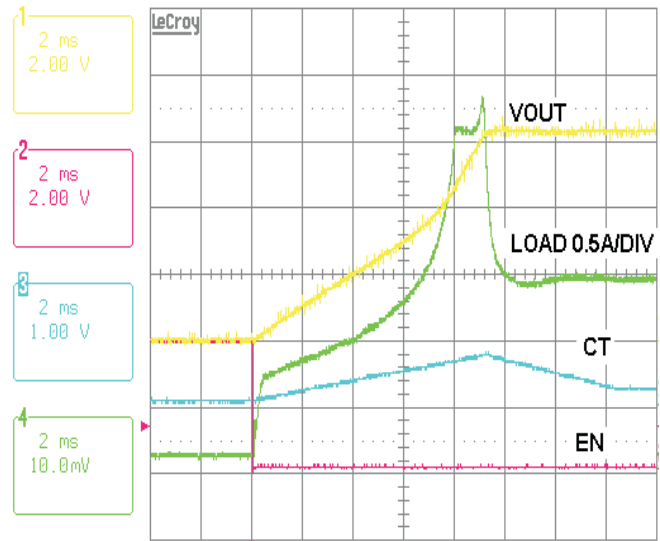

Figure 19. Start Up Into an RC Load (CT)

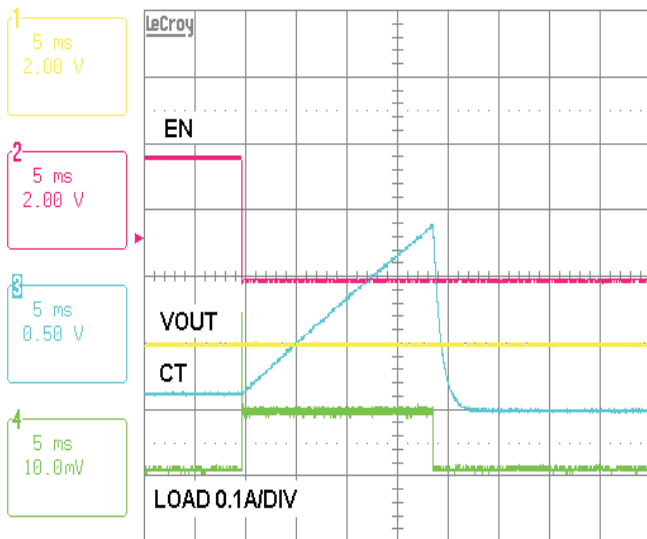

Figure 20. Start Up Into a Short Circuit Output

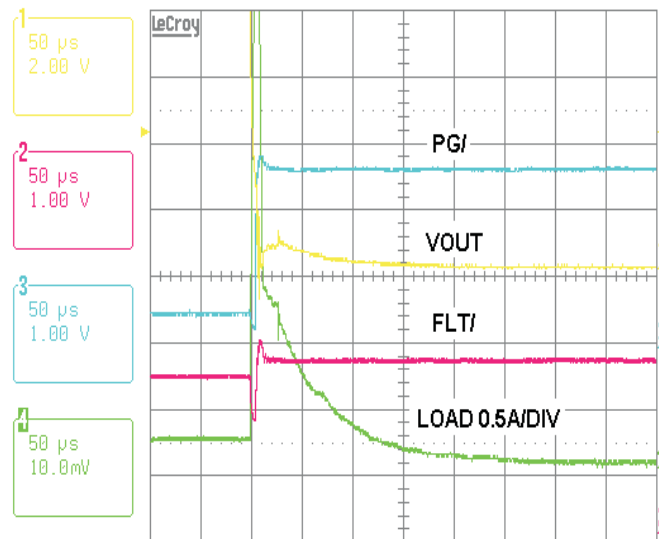

Figure 21. Device Output Short

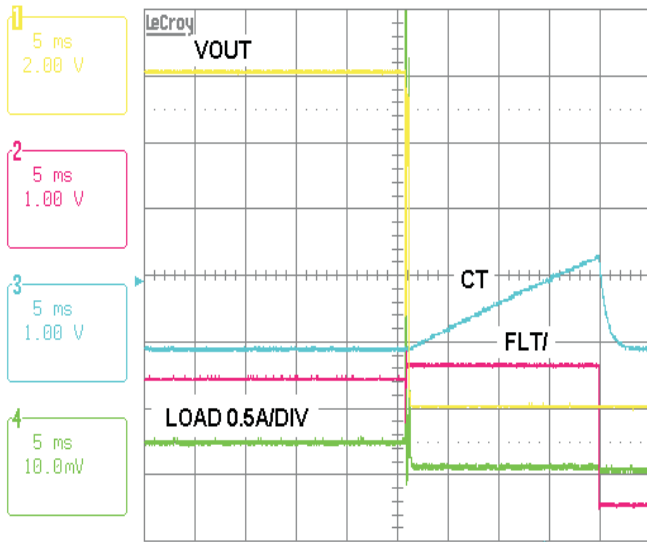

Figure 22.  $\overline{\text{FLT}}$  on Device Output Short

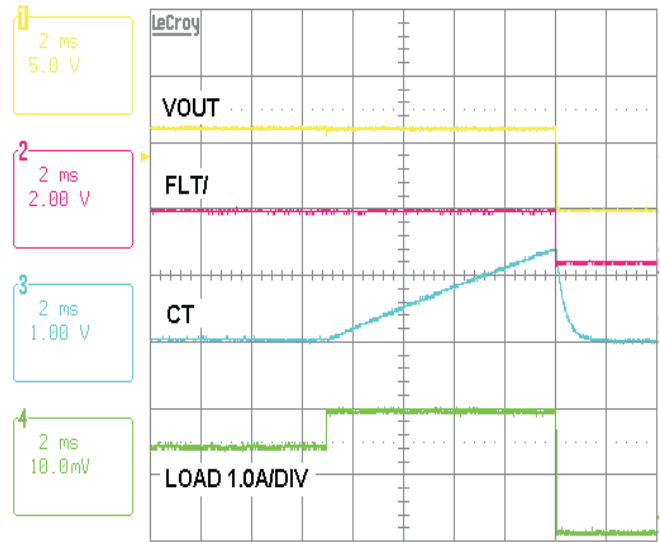

Figure 23. Overcurrent Shutdown

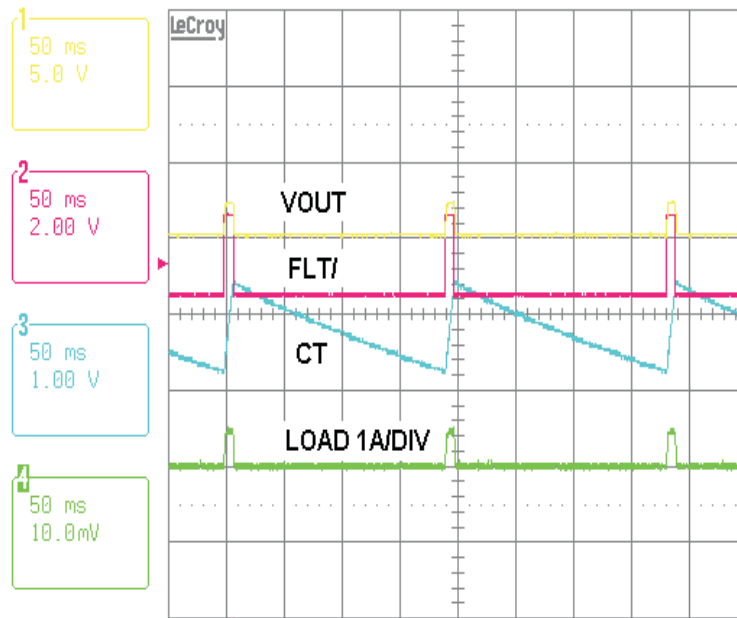
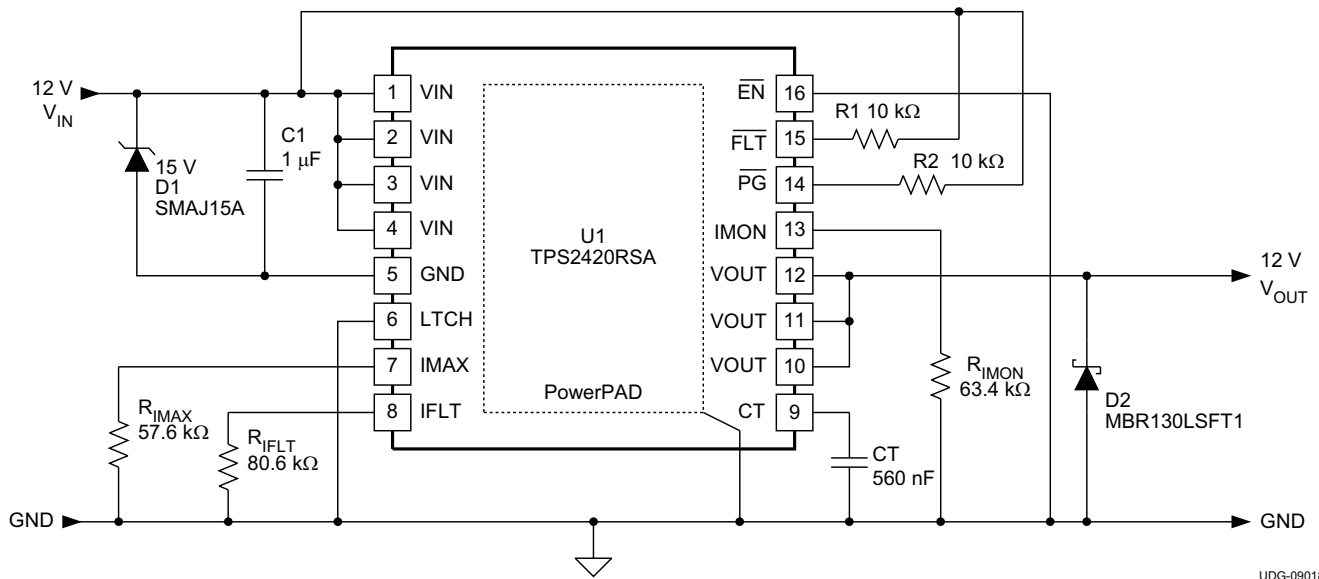

Figure 24. Retry Into an Output Short Circuit



UDG-09018

**Figure 25. TPS2420 Reference Design, 12-V, 2.5-A Steady State Current, 5-A Max Current**

**NOTE**

D1, D2, and C1 are required only in systems with significant feed, load inductance, or both.

To alter parameters  $I_{IAX}$ ,  $I_{FAULT}$ ,  $I_{IMON}$  or  $C_{CT}$  use the formulas in the *Pin Description* section or use [Table 2](#).



**Table 2. Typical Design Examples**

$I_{FAULT}$ (A)	$R_{IFLT}$ (kΩ)	$I_{IMAX}$ (A)	$R_{IMAX}$ (kΩ)	$C_{CT}$ (µF)	$T_{FAULT}$ (ms)	$T_{SD}$ (ms)	$I_{LOAD(max)}$ (A)	$R_{IMON}$ (kΩ)
1	200	2	100	0.022	0.86	22	1	158
1.5	133	2.5	80.6	0.047	1.83	47	1.5	105
2	100	3	65.5	0.1	3.89	100	2	78.7
2.5	80.6	3.5	56.2	0.22	8.56	220	2.5	63.4
3	65.5	4	49.9	0.47	18.28	470	3	52.3
3.5	56.2	4.5	44.2	0.68	26.45	680	3.5	45.3
4	49.9	5	40.2	1	38.9	1000	4	39.2

## REVISION HISTORY

<b>Changes from Revision A (March, 2010) to Revision B</b>	<b>Page</b>
<ul style="list-style-type: none"> <li>• Changed <a href="#">Table 2</a> - <math>T_{SD}</math> (ms) column values ..... 20</li> </ul>	20
<b>Changes from Revision B (July 2010) to Revision C</b>	<b>Page</b>
<ul style="list-style-type: none"> <li>• Added Feature: UL Listed - File Number E169910 ..... 1</li> </ul>	1
<b>Changes from Revision C (August 2010) to Revision D</b>	<b>Page</b>
<ul style="list-style-type: none"> <li>• Added IFLT may not be set below 1 A to maintain the Fault Current Limit threshold accuracy listed in the Electrical Characteristics table. Some parts may not current limit or fault as expected. .... 7</li> <li>• Changed Startup section text From: <math>I_{LIM}</math> set to 5 A To: to <math>I_{MAX}</math> set to 5 A ..... 15</li> <li>• Changed <a href="#">Table 1</a> Note 1 From: <math>I_{LIM} = 5</math> A To: <math>I_{MAX} = 5</math> A ..... 15</li> <li>• Changed Hard Overload - Fast Trip section text From: <math>1.6 \times I_{LIMIT}</math> to <math>1.6 \times I_{MAX}</math> ..... 16</li> <li>• Changed Overcurrent Shutdown section text From: <math>I_{LIMIT}</math> To: <math>I_{MAX}</math> ..... 16</li> </ul>	7 15 15 16 16
<b>Changes from Revision D (September 2011) to Revision E</b>	<b>Page</b>
<ul style="list-style-type: none"> <li>• Deleted <math>I_{FAULT}</math>, <math>I_{MAX}</math>, <math>C_T</math> Voltage from the ABSOLUTE MAXIMUM RATINGS table ..... 2</li> </ul>	2
<b>Changes from Revision E (May 2013) to Revision F</b>	<b>Page</b>
<ul style="list-style-type: none"> <li>• Deleted the minimum voltage from the voltage range listed in the document title, features list and description ..... 1</li> <li>• Added 5-A to document title ..... 1</li> <li>• Changed <i>listed</i> to <i>recognized</i> in last <i>FEATURES</i> bullet. Also added 2367 to UL number ..... 1</li> <li>• Added SSDs, PCIE, and Fan Control to the <i>APPLICATIONS</i> list ..... 1</li> <li>• Added UV turn-on threshold and bus text to the first paragraph of the <i>DESCRIPTION</i> ..... 1</li> <li>• Changed 3.0 V to 20.0 V to VIN in the schematic ..... 1</li> <li>• Deleted <i>PRODUCT INFORMATION</i> table ..... 2</li> </ul>	1 1 1 1 1 1 2

**PACKAGING INFORMATION**

Orderable Device	Status (1)	Package Type	Package Drawing	Pins	Package Qty	Eco Plan (2)	Lead finish/ Ball material (6)	MSL Peak Temp (3)	Op Temp (°C)	Device Marking (4/5)	Samples
TPS2420RSAR	ACTIVE	QFN	RSA	16	3000	RoHS & Green	NIPDAU	Level-2-260C-1 YEAR	-40 to 125	TPS 2420	
TPS2420RSAT	ACTIVE	QFN	RSA	16	250	RoHS & Green	NIPDAU	Level-2-260C-1 YEAR	-40 to 125	TPS 2420	

(1) The marketing status values are defined as follows:

**ACTIVE:** Product device recommended for new designs.

**LIFEBUY:** TI has announced that the device will be discontinued, and a lifetime-buy period is in effect.

**NRND:** Not recommended for new designs. Device is in production to support existing customers, but TI does not recommend using this part in a new design.

**PREVIEW:** Device has been announced but is not in production. Samples may or may not be available.

**OBSOLETE:** TI has discontinued the production of the device.

(2) **RoHS:** TI defines "RoHS" to mean semiconductor products that are compliant with the current EU RoHS requirements for all 10 RoHS substances, including the requirement that RoHS substance do not exceed 0.1% by weight in homogeneous materials. Where designed to be soldered at high temperatures, "RoHS" products are suitable for use in specified lead-free processes. TI may reference these types of products as "Pb-Free".

**RoHS Exempt:** TI defines "RoHS Exempt" to mean products that contain lead but are compliant with EU RoHS pursuant to a specific EU RoHS exemption.

**Green:** TI defines "Green" to mean the content of Chlorine (Cl) and Bromine (Br) based flame retardants meet JS709B low halogen requirements of <=1000ppm threshold. Antimony trioxide based flame retardants must also meet the <=1000ppm threshold requirement.

(3) MSL, Peak Temp. - The Moisture Sensitivity Level rating according to the JEDEC industry standard classifications, and peak solder temperature.

(4) There may be additional marking, which relates to the logo, the lot trace code information, or the environmental category on the device.

(5) Multiple Device Markings will be inside parentheses. Only one Device Marking contained in parentheses and separated by a "~" will appear on a device. If a line is indented then it is a continuation of the previous line and the two combined represent the entire Device Marking for that device.

(6) Lead finish/Ball material - Orderable Devices may have multiple material finish options. Finish options are separated by a vertical ruled line. Lead finish/Ball material values may wrap to two lines if the finish value exceeds the maximum column width.

**Important Information and Disclaimer:**The information provided on this page represents TI's knowledge and belief as of the date that it is provided. TI bases its knowledge and belief on information provided by third parties, and makes no representation or warranty as to the accuracy of such information. Efforts are underway to better integrate information from third parties. TI has taken and continues to take reasonable steps to provide representative and accurate information but may not have conducted destructive testing or chemical analysis on incoming materials and chemicals. TI and TI suppliers consider certain information to be proprietary, and thus CAS numbers and other limited information may not be available for release.

In no event shall TI's liability arising out of such information exceed the total purchase price of the TI part(s) at issue in this document sold by TI to Customer on an annual basis.

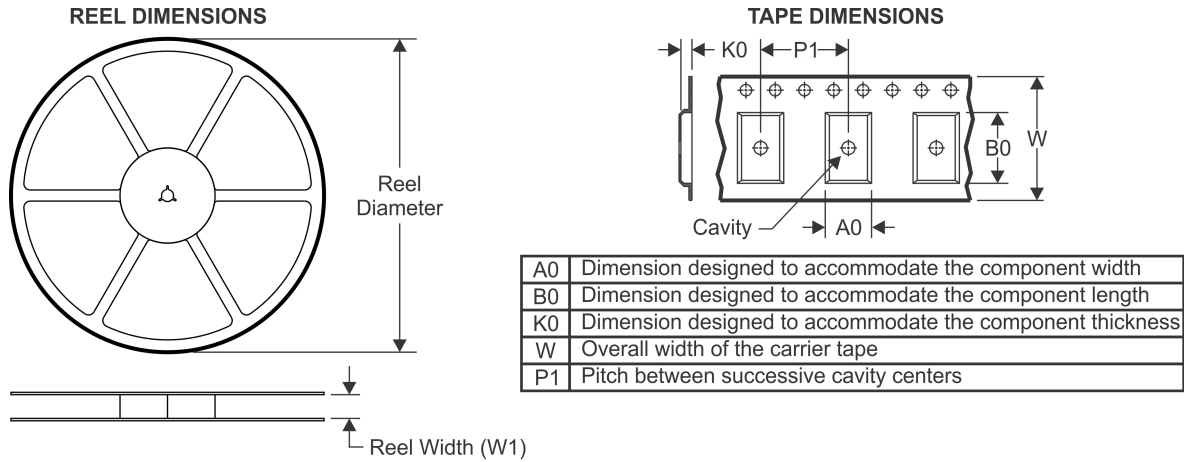

**TAPE AND REEL INFORMATION**

**QUADRANT ASSIGNMENTS FOR PIN 1 ORIENTATION IN TAPE**

\*All dimensions are nominal

Device	Package Type	Package Drawing	Pins	SPQ	Reel Diameter (mm)	Reel Width W1 (mm)	A0 (mm)	B0 (mm)	K0 (mm)	P1 (mm)	W (mm)	Pin1 Quadrant
TPS2420RSAR	QFN	RSA	16	3000	330.0	12.4	4.25	4.25	1.15	8.0	12.0	Q2
TPS2420RSAT	QFN	RSA	16	250	180.0	12.4	4.25	4.25	1.15	8.0	12.0	Q2

**TAPE AND REEL BOX DIMENSIONS**

\*All dimensions are nominal

Device	Package Type	Package Drawing	Pins	SPQ	Length (mm)	Width (mm)	Height (mm)
TPS2420RSAR	QFN	RSA	16	3000	367.0	367.0	35.0
TPS2420RSAT	QFN	RSA	16	250	210.0	185.0	35.0

RSA (S-PVQFN-N16)

PLASTIC QUAD FLATPACK NO-LEAD

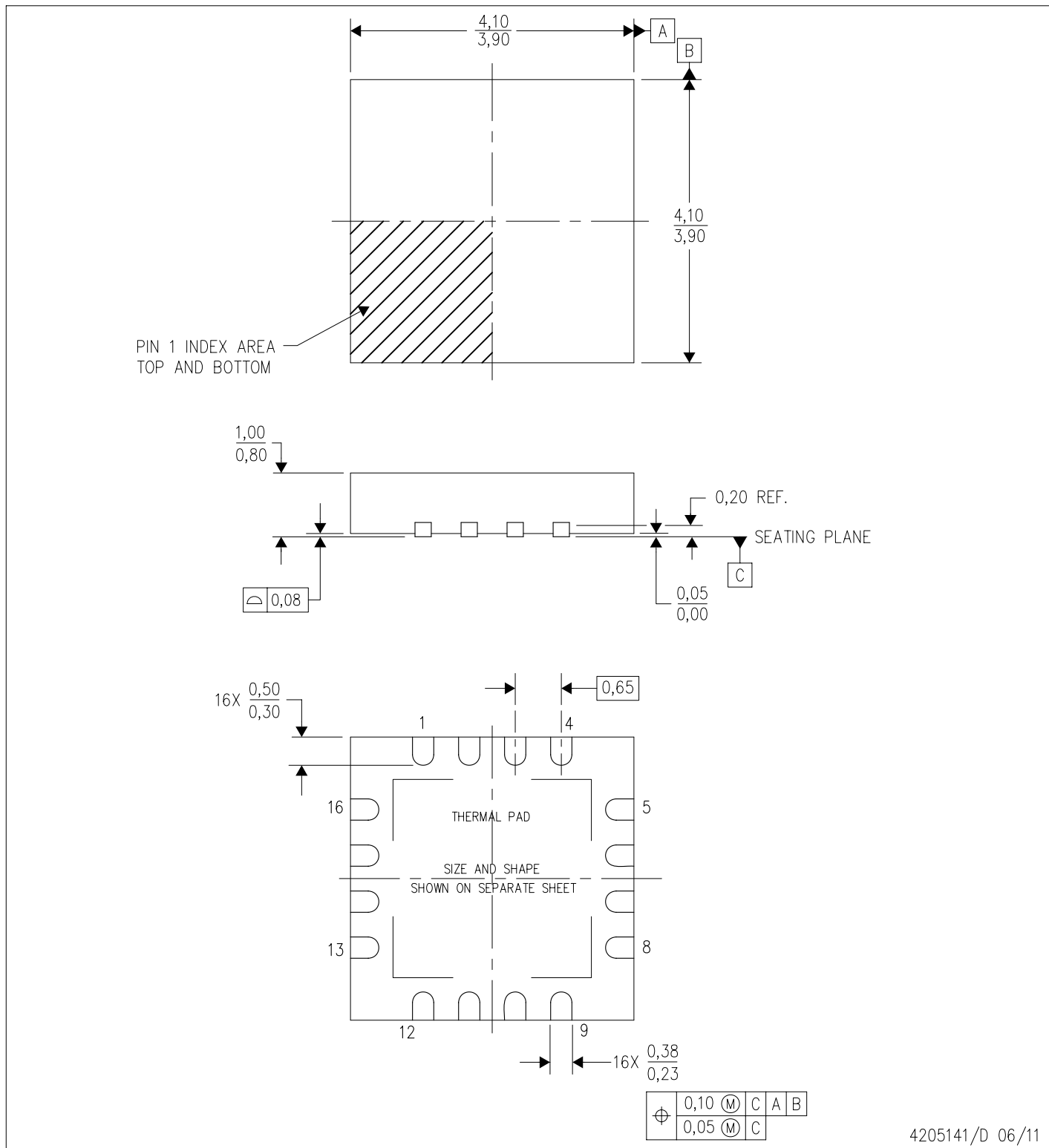

- NOTES:
- All linear dimensions are in millimeters. Dimensioning and tolerancing per ASME Y14.5M-1994.
  - This drawing is subject to change without notice.
  - Quad Flatpack, No-leads (QFN) package configuration.
  - The package thermal pad must be soldered to the board for thermal and mechanical performance.
  - See the additional figure in the Product Data Sheet for details regarding the exposed thermal pad features and dimensions.
  - Falls within JEDEC MO-220.

## THERMAL INFORMATION

This package incorporates an exposed thermal pad that is designed to be attached directly to an external heatsink. The thermal pad must be soldered directly to the printed circuit board (PCB). After soldering, the PCB can be used as a heatsink. In addition, through the use of thermal vias, the thermal pad can be attached directly to the appropriate copper plane shown in the electrical schematic for the device, or alternatively, can be attached to a special heatsink structure designed into the PCB. This design optimizes the heat transfer from the integrated circuit (IC).

For information on the Quad Flatpack No-Lead (QFN) package and its advantages, refer to Application Report, QFN/SON PCB Attachment, Texas Instruments Literature No. SLUA271. This document is available at [www.ti.com](http://www.ti.com).

The exposed thermal pad dimensions for this package are shown in the following illustration.

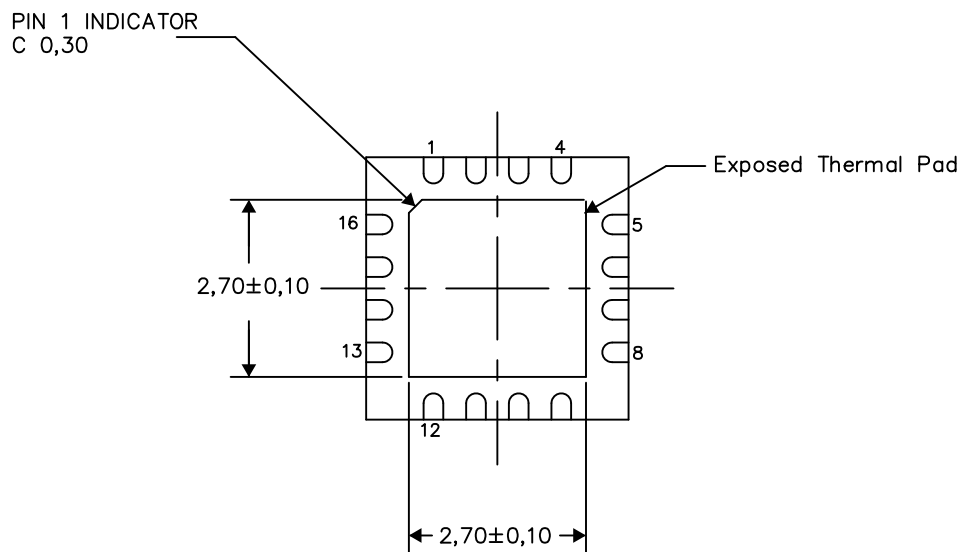

Bottom View

Exposed Thermal Pad Dimensions

4206364-2/0 09/15

### NOTES:

- A. All linear dimensions are in millimeters

RSA (S-PVQFN-N16)

PLASTIC QUAD FLATPACK NO-LEAD

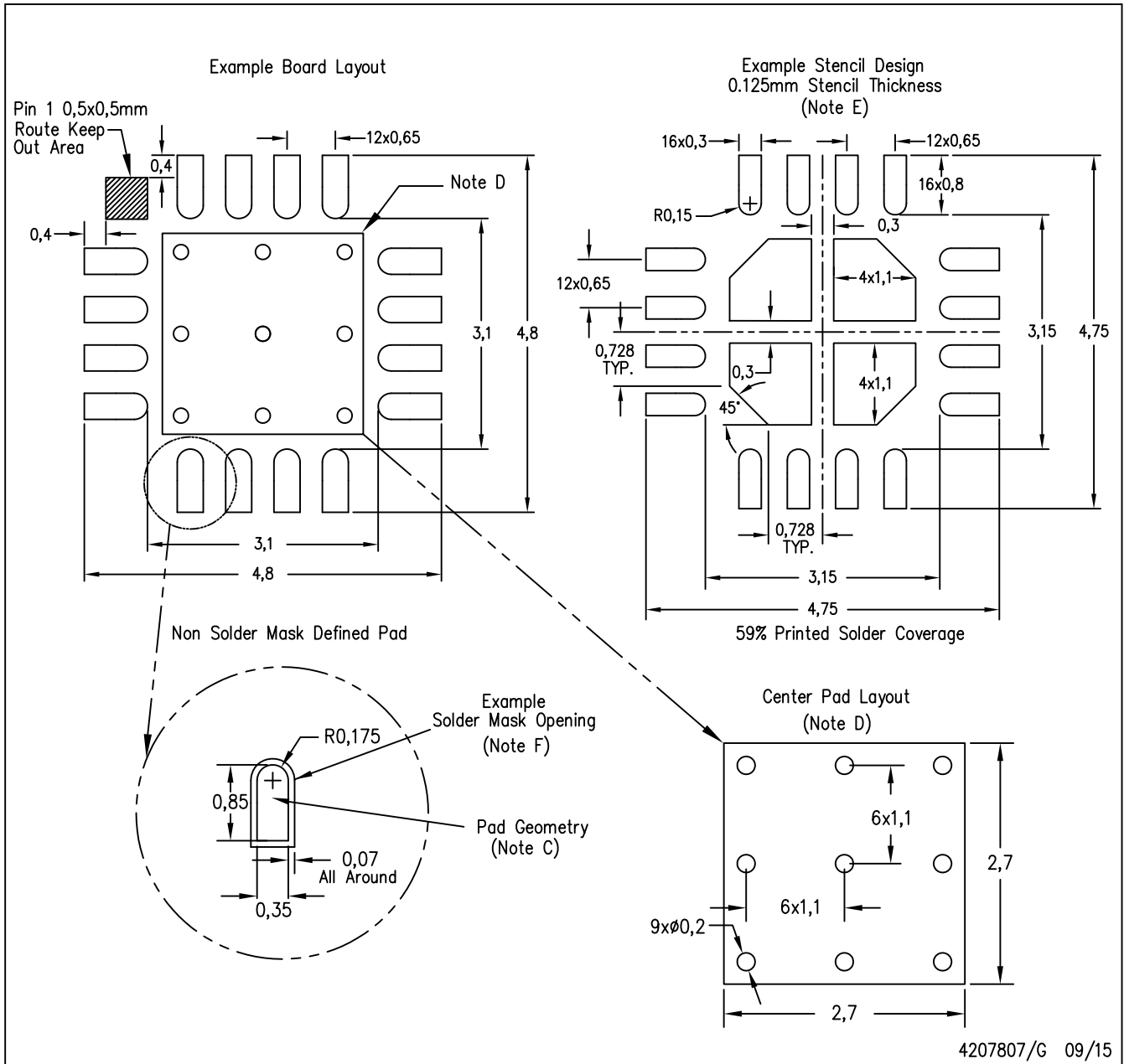

- NOTES:
- A. All linear dimensions are in millimeters.
  - B. This drawing is subject to change without notice.
  - C. Publication IPC-7351 is recommended for alternate designs.
  - D. This package is designed to be soldered to a thermal pad on the board. Refer to Application Note, QFN Packages, Texas Instruments Literature No. SLUA271, and also the Product Data Sheets for specific thermal information, via requirements, and recommended board layout. These documents are available at [www.ti.com](http://www.ti.com) <<http://www.ti.com>>.
  - E. Laser cutting apertures with trapezoidal walls and also rounding corners will offer better paste release. Customers should contact their board assembly site for stencil design recommendations. Refer to IPC 7525 for stencil design considerations.
  - F. Customers should contact their board fabrication site for solder mask tolerances.



NOTES:

1. All linear dimensions are in millimeters. Any dimensions in parenthesis are for reference only. Dimensioning and tolerancing per ASME Y14.5M.
2. This drawing is subject to change without notice.
3. This dimension does not include mold flash, protrusions, or gate burrs. Mold flash, protrusions, or gate burrs shall not exceed 0.15 mm per side.
4. This dimension does not include interlead flash. Interlead flash shall not exceed 0.25 mm per side.
5. Reference JEDEC registration MO-153.

# EXAMPLE BOARD LAYOUT

PW0016A

TSSOP - 1.2 mm max height

SMALL OUTLINE PACKAGE



LAND PATTERN EXAMPLE  
EXPOSED METAL SHOWN  
SCALE: 10X



SOLDER MASK DETAILS

4220204/A 02/2017

NOTES: (continued)

- 6. Publication IPC-7351 may have alternate designs.
- 7. Solder mask tolerances between and around signal pads can vary based on board fabrication site.

# EXAMPLE STENCIL DESIGN

PW0016A

TSSOP - 1.2 mm max height

SMALL OUTLINE PACKAGE

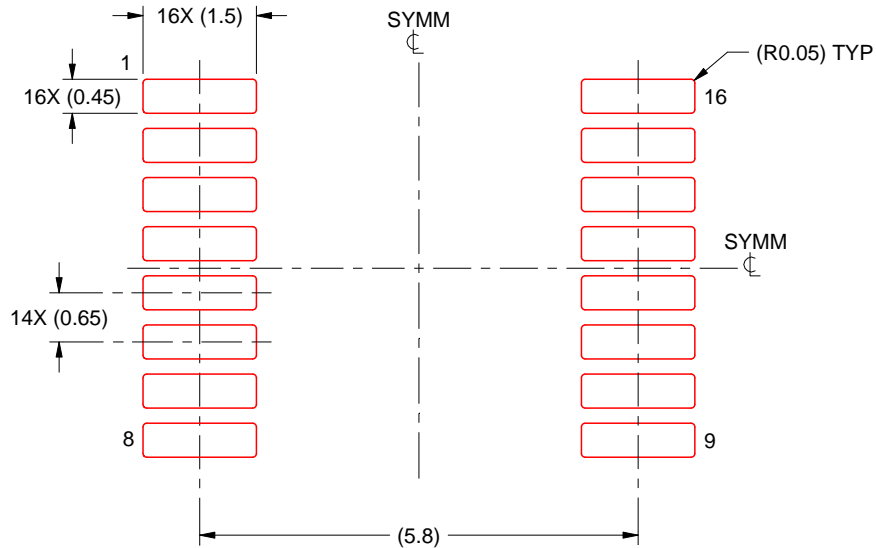

SOLDER PASTE EXAMPLE  
BASED ON 0.125 mm THICK STENCIL  
SCALE: 10X

4220204/A 02/2017

NOTES: (continued)

8. Laser cutting apertures with trapezoidal walls and rounded corners may offer better paste release. IPC-7525 may have alternate design recommendations.
9. Board assembly site may have different recommendations for stencil design.

## IMPORTANT NOTICE AND DISCLAIMER

TI PROVIDES TECHNICAL AND RELIABILITY DATA (INCLUDING DATASHEETS), DESIGN RESOURCES (INCLUDING REFERENCE DESIGNS), APPLICATION OR OTHER DESIGN ADVICE, WEB TOOLS, SAFETY INFORMATION, AND OTHER RESOURCES "AS IS" AND WITH ALL FAULTS, AND DISCLAIMS ALL WARRANTIES, EXPRESS AND IMPLIED, INCLUDING WITHOUT LIMITATION ANY IMPLIED WARRANTIES OF MERCHANTABILITY, FITNESS FOR A PARTICULAR PURPOSE OR NON-INFRINGEMENT OF THIRD PARTY INTELLECTUAL PROPERTY RIGHTS.

These resources are intended for skilled developers designing with TI products. You are solely responsible for (1) selecting the appropriate TI products for your application, (2) designing, validating and testing your application, and (3) ensuring your application meets applicable standards, and any other safety, security, or other requirements. These resources are subject to change without notice. TI grants you permission to use these resources only for development of an application that uses the TI products described in the resource. Other reproduction and display of these resources is prohibited. No license is granted to any other TI intellectual property right or to any third party intellectual property right. TI disclaims responsibility for, and you will fully indemnify TI and its representatives against, any claims, damages, costs, losses, and liabilities arising out of your use of these resources.

TI's products are provided subject to TI's Terms of Sale ([www.ti.com/legal/termsofsale.html](http://www.ti.com/legal/termsofsale.html)) or other applicable terms available either on [ti.com](http://ti.com) or provided in conjunction with such TI products. TI's provision of these resources does not expand or otherwise alter TI's applicable warranties or warranty disclaimers for TI products.

Mailing Address: Texas Instruments, Post Office Box 655303, Dallas, Texas 75265  
Copyright © 2020, Texas Instruments Incorporated