

CDCM9102 低噪声双通道 100MHz 时钟发生器

1 特性

- 包括锁相环路 (PLL)、压控振荡器 (VCO)、和回路滤波器的集成型低噪声时钟生成器
- 2 个低噪声 100MHz 时钟 (低电压正射极耦合逻辑 (LVPECL), 低压差分信号 (LVDS), 或者低压 CMOS (LVCOMS) 对)
 - 支持高速电流控制逻辑 (HCSL) 信号传输电平 (交流耦合)
 - 典型周期抖动: 峰值到峰值 (pk-pk) 21ps
 - 典型随机抖动: 510ps RMS
 - 由引脚设定的输出类型
- 附加单端 25MHz 输出
- 集成晶振输入接受 25MHz 晶振
- 输出使能引脚, 可关断器件和输出
- 32 引脚 5mm x 5mm 超薄型四方扁平无引线 (VQFN) 封装
- 静电放电 (ESD) 保护超过 2000V 人体模型 (HBM) 和 500V 带电器件模型 (CDM)
- 工业温度范围 (-40°C 至 85°C)
- 3.3V 电源

2 应用范围

- PCI Express
1 代、2 代和 3 代的基准时钟生成
- 通用计时

3 说明

CDCM9102 是一款为诸如 PCI Express™ 的通信标准提供基准时钟而设计的低抖动时钟生成器。该器件最高支持 PCIE 3 代, 易于配置和使用。CDCM9102 提供 2 个 100MHz 差分时钟端口。这些端口支持的输出类型包括 LVPECL, LVDS, 或者一对 LVCMOS 缓冲器。HCSL 信号传输由交流耦合网络提供支持。用户配置捆绑器件引脚所需的输出缓冲器类型。此外, 提供一个单端 25 MHz 时钟输出端口。这一端口的使用包括通用计时、计时以太网物理层 (PHY)、或者为附加的时钟生成器提供一个基准时钟。所有生成的时钟来自一个单一外部 25MHz 晶体。

器件信息⁽¹⁾

器件型号	封装	封装尺寸 (标称值)
CDCM9102	VQFN (32)	5.00mm x 5.00mm

(1) 要了解所有可用封装, 请见数据表末尾的可订购产品附录。

简化电路原理图

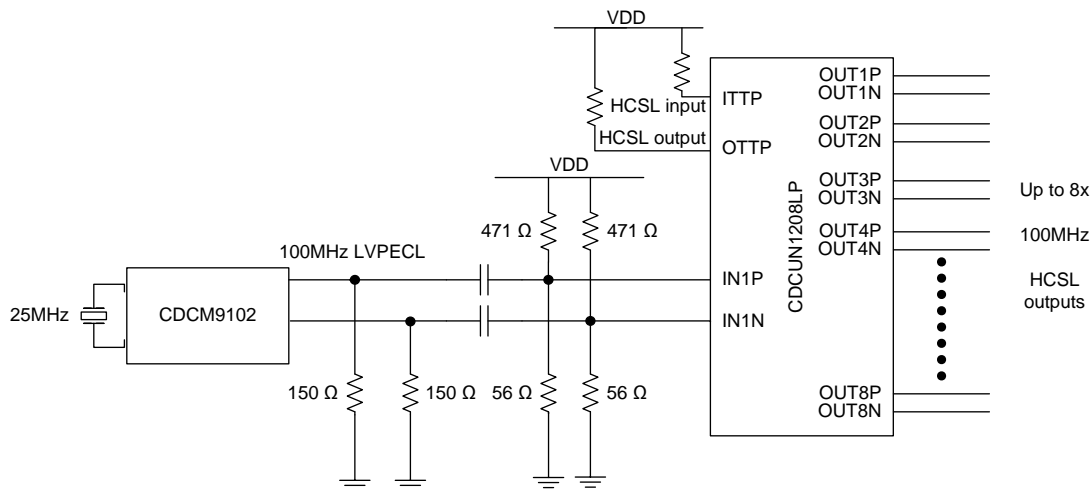

Copyright © 2016, Texas Instruments Incorporated



目录

1	特性	1	9.2	Functional Block Diagrams	10
2	应用范围	1	9.3	Feature Description	10
3	说明	1	9.4	Device Functional Modes	10
4	修订历史记录	2	9.5	Programming	12
5	Device Comparison Table	3	10	Application and Implementation	13
6	Pin Configuration and Functions	3	10.1	Application Information	13
7	Specifications	5	10.2	Typical Application	16
7.1	Absolute Maximum Ratings	5	11	Power Supply Recommendations	19
7.2	ESD Ratings	5	11.1	Thermal Management	19
7.3	Recommended Operating Conditions	5	11.2	Power Supply Filtering	19
7.4	Thermal Information	5	12	Layout	20
7.5	Electrical Characteristics	6	12.1	Layout Guidelines	20
7.6	Timing Requirements	7	12.2	Layout Example	20
7.7	Typical Characteristics	7	13	器件和文档支持	21
8	Parameter Measurement Information	8	13.1	社区资源	21
8.1	Test Configurations	8	13.2	商标	21
9	Detailed Description	10	13.3	静电放电警告	21
9.1	Overview	10	13.4	Glossary	21
			14	机械、封装和可订购信息	21

4 修订历史记录

注：之前版本的页码可能与当前版本有所不同。

Changes from Original (February 2012) to Revision A

Page

• 已添加 ESD 额定值表，特性 描述部分，器件功能模式，应用和实施部分，电源相关建议部分，布局部分，器件和文档支持部分以及机械、封装和可订购信息部分	1
• 已添加 文本至说明“该器件最高支持 PCIE 3 代，”	1
• Changed part number to 1134 25M0000000	11
• Changed part number to FP2500002	11
• Added text and Figure 16 to <i>PCI Express Applications</i>	15

5 Device Comparison Table

PACKAGED DEVICES	FEATURES	T _A
CDCM9102RHBT	32-pin VQFN (RHB) package, small tape and reel	–40°C to 85°C
CDCM9102RHBR	32-pin VQFN (RHB) package, tape and reel	

6 Pin Configuration and Functions

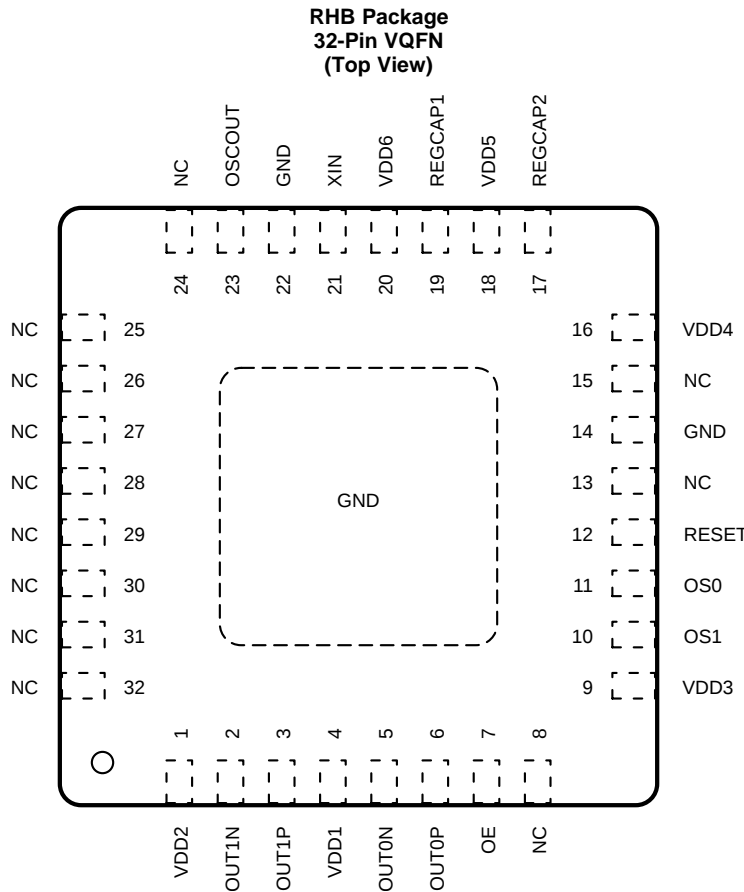

Pin Functions

PIN		TYPE ⁽¹⁾	DESCRIPTION
NAME	NO.		
POWER SUPPLIES			
GND	Thermal pad, 14, 22	G	Power supply ground and thermal relief
REGCAP1	19	P	Capacitor for internal regulator, connect 10- μ F Y5V capacitor to GND
REGCAP2	17	P	Capacitor for internal regulator, connect 10- μ F Y5V capacitor to GND
VDD1	4	P	Power Supply, OUT0 clock port
VDD2	1	P	Power Supply, OUT1 clock port
VDD3	9	P	Power supply, low-noise clock generator
VDD4	16	P	Power supply, low-noise clock generator
VDD5	18	P	Power supply, low-noise clock generator
VDD6	20	P	Power supply, crystal oscillator input

(1) G = Ground, I = Input, O = Output, P = Power

Pin Functions (continued)

PIN		TYPE ⁽¹⁾	DESCRIPTION
NAME	NO.		
DEVICE CONFIGURATION AND CONTROL			
NC	8, 13, 15, 24–32	—	No connection permitted
OE	7	O	Output enable/shutdown control input (see Table 2)
OS1	10	O	Output format select control inputs (see Table 3)
OS0	11	O	Output format select control inputs (see Table 3)
RESET	12	I	Device reset input (active-low) (see Table 4) ⁽²⁾
CRYSTAL OSCILLATOR			
XIN	21	I	Parallel resonant crystal input (25 MHz)
DEVICE OUTPUTS			
OSCOU	23	O	Oscillator output port (25 MHz)
OUT0N	5	O	Output 0 – negative terminal (100 MHz)
OUT0P	6	O	Output 0 – positive terminal (100 MHz)
OUT1N	2	O	Output 1 – negative terminal (100 MHz)
OUT1P	3	O	Output 1 – positive terminal (100 MHz)

(2) For proper device startup, it is recommended that a capacitor be installed from pin 12 to GND. See [Start-Up Time Estimation](#) for more details.

7 Specifications

7.1 Absolute Maximum Ratings

over operating free-air temperature range (unless otherwise noted)⁽¹⁾

		MIN	MAX	UNIT
I_{IN}	Input current		20	mA
I_{OUT}	Output current		50	mA
V_{DDx}	Supply voltage ⁽²⁾	-0.5	4.6	V
V_{IN}	Input voltage ⁽³⁾	-0.5	$V_{DDx} + 0.5$	V
V_{OUT}	Output voltage ⁽³⁾	-0.5	$V_{DDx} + 0.5$	V
T_A	Operating temperature		85	°C
T_{stg}	Storage temperature	-65	150	°C

- (1) Stresses beyond those listed under *Absolute Maximum Ratings* may cause permanent damage to the device. These are stress ratings only, which do not imply functional operation of the device at these or any other conditions beyond those indicated under *Recommended Operating Conditions*. Exposure to absolute-maximum-rated conditions for extended periods may affect device reliability.
- (2) Supply voltages must be applied simultaneously.
- (3) The input and output negative voltage ratings may be exceeded if the input and output clamp-current ratings are observed

7.2 ESD Ratings

		VALUE	UNIT
$V_{(ESD)}$	Electrostatic discharge	Human-body model (HBM), per ANSI/ESDA/JEDEC JS-001 ⁽¹⁾	±2000
		Charged-device model (CDM), per JEDEC specification JESD22-C101 ⁽²⁾	±500

- (1) JEDEC document JEP155 states that 500-V HBM allows safe manufacturing with a standard ESD control process.
- (2) JEDEC document JEP157 states that 250-V CDM allows safe manufacturing with a standard ESD control process.

7.3 Recommended Operating Conditions

		MIN	NOM	MAX	UNIT
V_{DDX}	DC power-supply voltage	3	3.3	3.6	V
T_A	Ambient temperature	-40		85	°C

7.4 Thermal Information

THERMAL METRIC ⁽¹⁾⁽²⁾	CDCM9102	UNIT	
	RHB (VQFN)		
	32 PINS		
$R_{\theta JA}$	Junction-to-ambient thermal resistance	33.1	°C/W
$R_{\theta JC(top)}$	Junction-to-case (top) thermal resistance	25.7	°C/W
$R_{\theta JB}$	Junction-to-board thermal resistance	0.3	°C/W
Ψ_{JT}	Junction-to-top characterization parameter	7.1	°C/W
Ψ_{JB}	Junction-to-board characterization parameter	2	°C/W
$R_{\theta JC(bot)}$	Junction-to-case (bottom) thermal resistance	6.12	°C/W

- (1) For more information about traditional and new thermal metrics, see the *Semiconductor and IC Package Thermal Metrics* application report, [SPRA953](#).
- (2) 4 × 4 Vias on Pad.

7.5 Electrical Characteristics

over operating free-air temperature range (unless otherwise noted)

PARAMETER		TEST CONDITIONS	MIN	TYP	MAX	UNIT
LVC MOS INPUTS⁽¹⁾						
V _{IH}	Input high voltage		0.6 × V _{DD}			V
V _{IL}	Input low voltage			0.4 × V _{DD}		V
I _{IH}	Input high current	V _{DD} = 3.6 V, V _{IL} = 0 V			200	μA
I _{IL}	Input low current	V _{DD} = 3 V, V _{IH} = 3.6 V			–200	μA
C _{IN}	Input capacitance			8	10	pF
R _{PU}	Input pullup resistor			150		kΩ
CRYSTAL CHARACTERISTICS (XIN)⁽²⁾						
f _{XTAL}	Crystal input frequency	Fundamental mode		25		MHz
ESR	Effective series resistance of crystal				50	Ω
C _{IN}	On-chip load capacitance			8	10	pF
XTAL _{DL}	Maximum drive level - XTAL		0.1		1	mW
C _{SHUNT}	Maximum shunt capacitance				7	pF
CLOCK OUTPUT BUFFER (OUTPUT MODE = LVPECL)⁽³⁾						
V _{OH}	Output high voltage		V _{DD} – 1.18	V _{DD} – 0.73		V
V _{OL}	Output low voltage		V _{DD} – 2	V _{DD} – 1.55		V
V _{OD}	Differential output voltage		0.6		1.23	V
t _R and t _F	Output rise and fall time	20% to 80%			175	ps
ODC	Output duty cycle		45%		55%	
t _{SKEW}	Skew between outputs				20	ps
CLOCK OUTPUT BUFFER (OUTPUT MODE = LVDS)⁽⁴⁾						
V _{OD}	Differential output voltage		0.247		0.454	V
ΔV _{OD}	V _{OD} magnitude change				50	mV
V _{OS}	Common-mode voltage		1.125		1.375	V
ΔV _{OS}	V _{OS} magnitude change				50	mV
t _R and t _F	Output rise and fall time	20% to 80%			255	ps
ODC	Output duty cycle		45%		55%	
t _{SKEW}	Skew between outputs				30	ps
CLOCK OUTPUT BUFFER (OUTPUT MODE = LVCMOS)⁽⁵⁾						
V _{OH}	Output high voltage	V _{CC} = 3 V to 3.6 V, I _{OH} = –100 μA	V _{DD} – 0.5			V
V _{OL}	Output low voltage	V _{CC} = 3 V to 3.6 V, I _{OH} = 100 μA			0.3	V
t _{SLEW}	Output rise/fall slew rate	20% to 80%		2.4		V/ns
ODC	Output duty cycle		45%		55%	
t _{SKEW}	Skew between outputs				50	ps

 (1) LVC MOS inputs at T_A = –40°C to 85°C

 (2) Crystal characteristics for external 25 MHz crystal with V_{DD} = 3.3 V, T_A = –40°C to 85°C

 (3) Clock output buffer with output mode = LVPECL at VDD1, VDD2 = 3.3 V; T_A = –40°C to 85°C

 (4) Clock output buffer with output mode = LVDS at VDD1, VDD2 = 3.3 V; T_A = –40°C to 85°C

 (5) Clock output buffer with output mode = LVCMOS at VDD1, VDD2 = 3.3 V; T_A = –40°C to 85°C

7.6 Timing Requirements

$f_{OUT} = 100 \text{ MHz}$, $V_{DD} = 3.3 \text{ V}$, $T_A = 25^\circ\text{C}$, and jitter integration bandwidth between 10 kHz and 20 MHz (unless otherwise noted)

	MIN	TYP	MAX	UNIT
LVCMOS OUTPUT MODE				
Random jitter			507	fs RMS
Period jitter			24.5	ps pk-pk
LVPECL OUTPUT MODE				
Random jitter			510	fs RMS
Period jitter			20.7	ps pk-pk
LVDS OUTPUT MODE				
Random jitter			533	fs RMS
Period jitter			26.5	ps pk-pk

7.7 Typical Characteristics

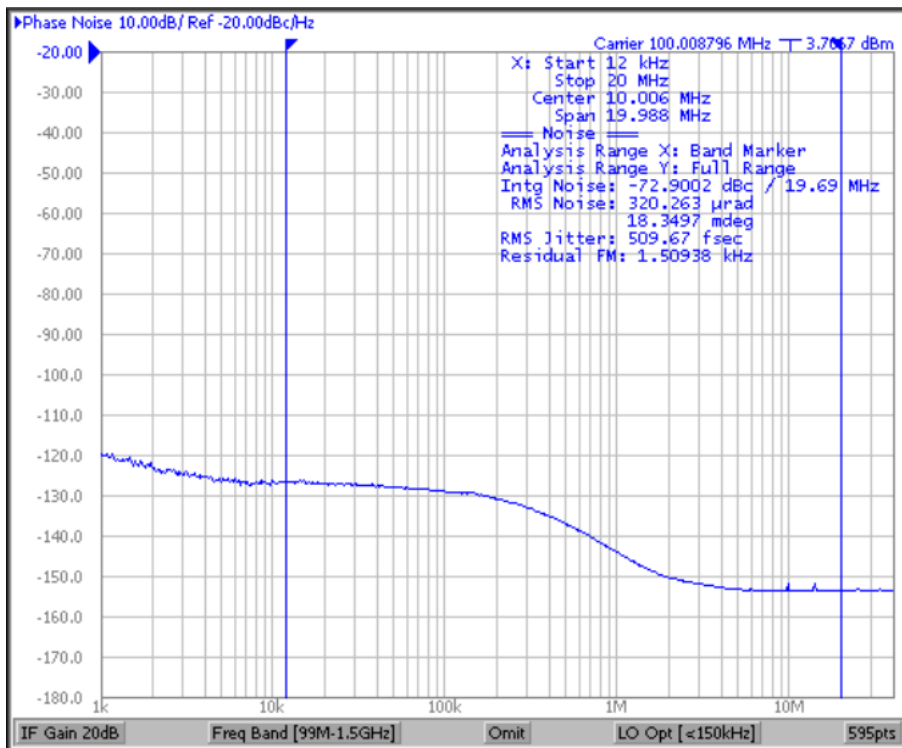

Figure 1. CDCM9102 Typical Phase Noise Performance (LVPECL Mode)

8 Parameter Measurement Information

8.1 Test Configurations

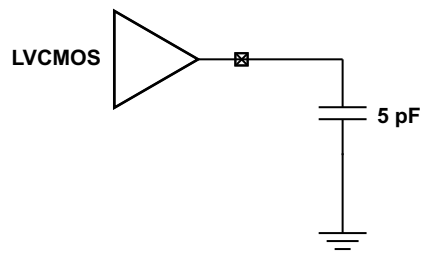

Figure 2. LVC MOS Output Test Load

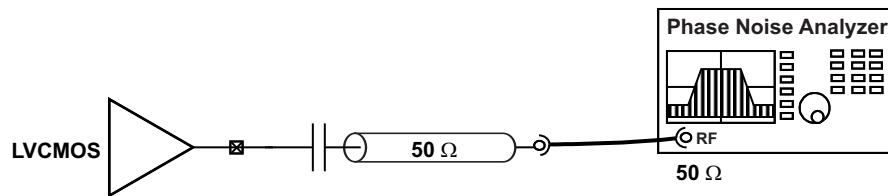

Figure 3. LVC MOS AC Configuration for Device Test

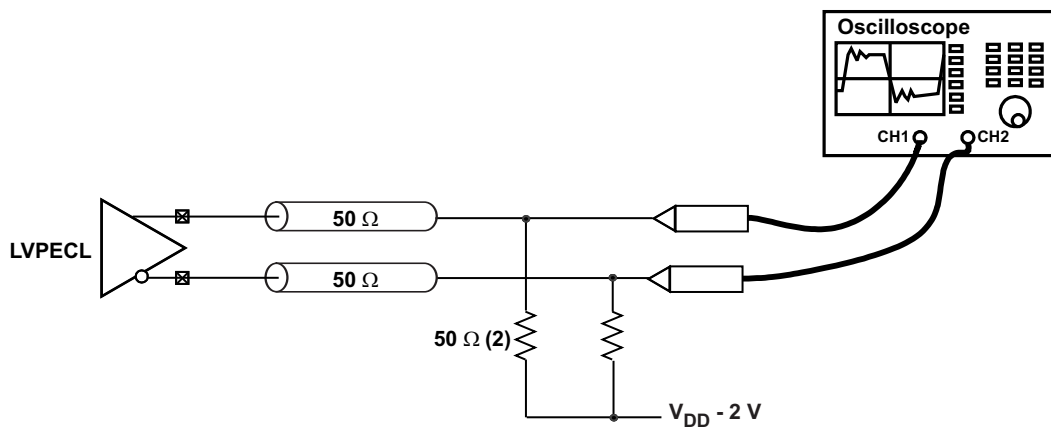

Figure 4. LVPECL DC Configuration for Device Test

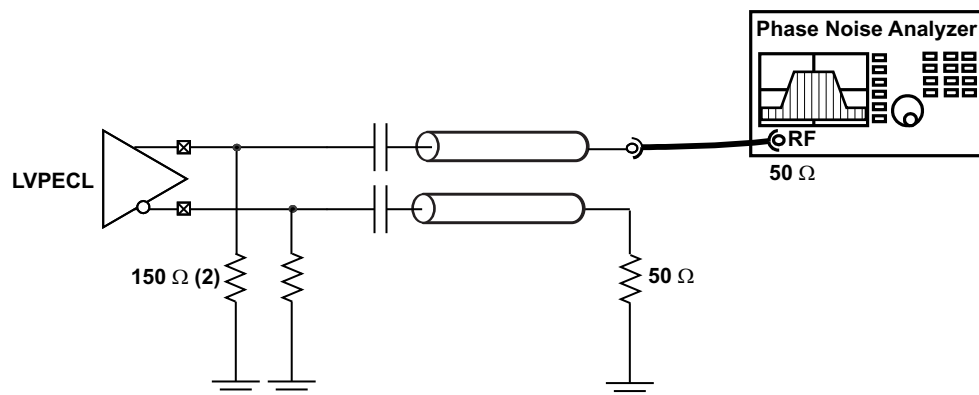

Figure 5. LVPECL AC Configuration for Device Test

Test Configurations (continued)

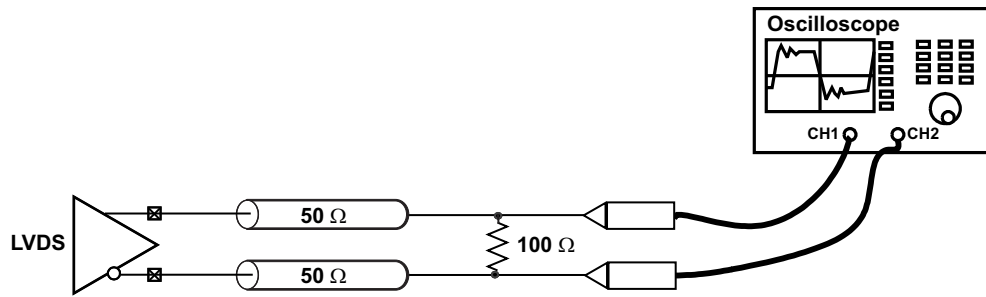

Figure 6. LVDS DC Configuration for Device Test

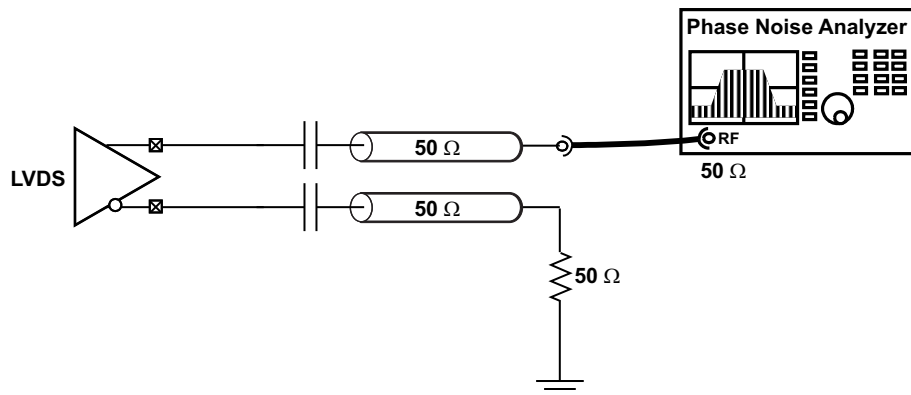

Figure 7. LVDS AC Configuration for Device Test

9 Detailed Description

9.1 Overview

The CDCM9102 is a high-performance PLL that generates 2 copies of commonly-used reference clocks with less than 1-ps RMS jitter from a low-cost crystal.

9.2 Functional Block Diagrams

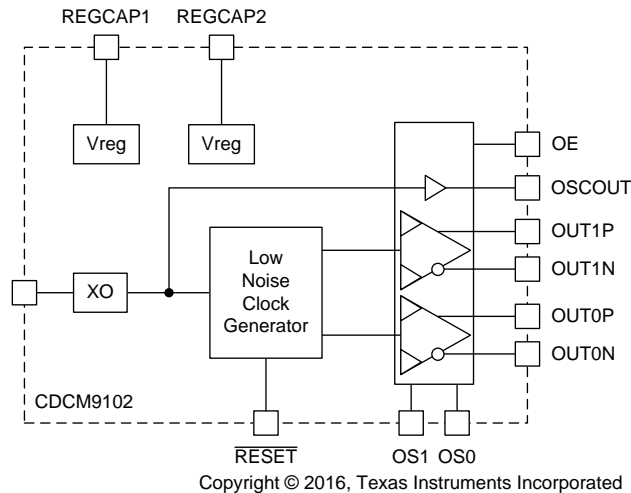

9.3 Feature Description

The CDCM9102 includes an on-chip PLL with an on-chip VCO. The PLL blocks consist of a crystal input interface, a phase frequency detector (PFD), a charge pump, an on-chip loop filter, and prescaler and feedback dividers. Completing the CDCM9102 device are the output divider and universal output buffer. The PLL and output divider are pre-programmed to generate 2 copies of 100 MHz in LVCMOS, LVPECL or LVDS format.

The PLL is powered by on-chip, low-dropout (LDO) linear voltage regulators. The regulated supply network is partitioned such that the sensitive analog supplies are powered from separate LDOs rather than the digital supplies which use a separate LDO regulator. These LDOs provide isolation for the PLL from any noise in the external power-supply rail. The REG_CAP1 and REG_CAP2 pins should each be connected to ground by 10- μ F capacitors to ensure stability.

9.4 Device Functional Modes

9.4.1 Crystal Input (XIN) Interface

The CDCM9102 implements a *Colpitts oscillator*, therefore, one side of the crystal connects to the XIN pin and the other crystal terminal connects to ground. The device requires the use of a fundamental-mode crystal, and the oscillator operates in parallel resonance mode. The correct load capacitance is necessary to ensure that the circuit oscillates properly. The load capacitance comprises all capacitances in the oscillator feedback loop (the capacitances seen between the terminals of the crystal in the circuit). It is important to account for all sources of capacitance when calculating the correct value for the external discrete load capacitance shown in [Figure 8](#).

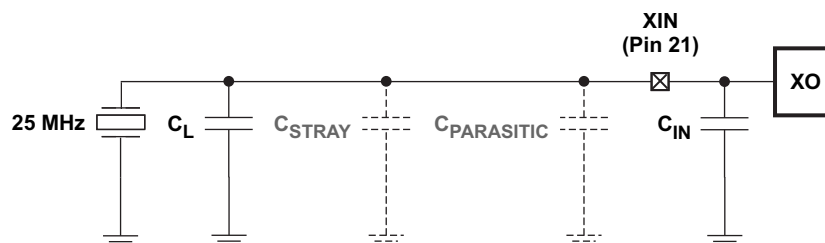

Figure 8. Configuration of Circuit for CDCM9102 XIN Oscillator

Device Functional Modes (continued)

The CDCM9102 has been characterized with 10-pF parallel-resonant crystals. The input stage of the crystal oscillator in the CDCM9102 is designed to oscillate at the correct frequency for all parallel-resonant crystals with low-pull capability and rated with a load capacitance that is equal to the sum of the on-chip load capacitance at the XIN pin ($C_{IN} = 10$ pF maximum), crystal stray capacitance, and board parasitic capacitance between the crystal and XIN pin. To minimize stray and parasitic capacitances, minimize the trace distance routed from the crystal to the XIN pin and avoid other active traces and active circuitry in the area of the crystal oscillator circuit. [Table 1](#) lists crystal types that have been evaluated with the CDCM9102.

Table 1. CDCM9102 Crystal Recommendations

MANUFACTURER	PART NUMBER
Vectron	VXC1-1134 25M0000000
Fox	218-3
Saronix	FP2500002

A mismatch of the load capacitance results in a frequency error according to [Equation 1](#).

$$\frac{\Delta f}{f} = \frac{C_S}{2(C_{Lr} + C_O)} - \frac{C_S}{2(C_{La} + C_O)}$$

where

- Δf is the frequency error required by the application.
- f is the fundamental frequency of the crystal.
- C_S is the motional capacitance of the crystal. This is a parameter in the data sheet of the crystal.
- C_O is the shunt capacitance of the crystal. This is a parameter in the data sheet of the crystal.
- C_{Lr} is the rated load capacitance of the crystal. This is a parameter in the data sheet of the crystal.
- C_{La} is the actual load capacitance implemented on the PCB ($C_{IN} + \text{stray capacitance} + \text{parasitic capacitance} + C_L$). (1)

The difference between the rated load capacitance (from the crystal datasheet) and the actual load capacitance ($C_{La} = C_{IN} + C_L + C_{STRAY} + C_{PARASITIC}$) should be minimized. A crystal with a low pullability rating (low C_S) is ideal.

Design Example:

Desired frequency tolerance $\Delta f \leq \pm 80$ ppm

Crystal Vendor Parameters:

Intrinsic Frequency Tolerance = ± 30 ppm

$C_O = 7$ pF (shunt capacitance)

$C_S = 10$ fF (motional capacitance)

$C_{Lr} = 12$ pF (load capacitance)

Substituting these parameters into [Equation 1](#) yields a maximum value of $C_{La} = 17$ pF to achieve the desired Δf (± 50 ppm). Recall that $C_{La} = C_{IN} + C_L + C_{STRAY} + C_{PARASITIC} = 8$ pF + ($C_L + C_{STRAY} + C_{PARASITIC}$). Ideally, the load presented to this crystal should be 12 pF; therefore, the sum of ($C_L + C_{STRAY} + C_{PARASITIC}$) must be less than 9 pF. Stray and parasitic capacitance must be controlled. This is because the Colpitts oscillator is particularly sensitive to capacitance in parallel with the crystal; therefore, good layout practice is essential. TI recommends that the designer extract the stray and parasitic capacitance from the printed-circuit board design tool and adjust C_L accordingly to achieve $C_{Lr} = C_{La}$. In common scenarios, the external load capacitor is often unnecessary; however, TI recommends that pads be implemented to accommodate an external load capacitor so that the ppm error can be minimized.

9.4.2 Interfacing between LVPECL and HCSL (PCI Express)

Certain PCI Express applications require HCSL signaling. Because the common-mode voltage for LVPECL and HCSL are different, applications requiring HCSL signaling must use AC-coupling as shown in [Figure 9](#). The 150- Ω resistors ensure proper biasing of the CDCM9102 LVPECL output stage. The 471- Ω and 56- Ω resistor network biases the HCSL receiver input stage.

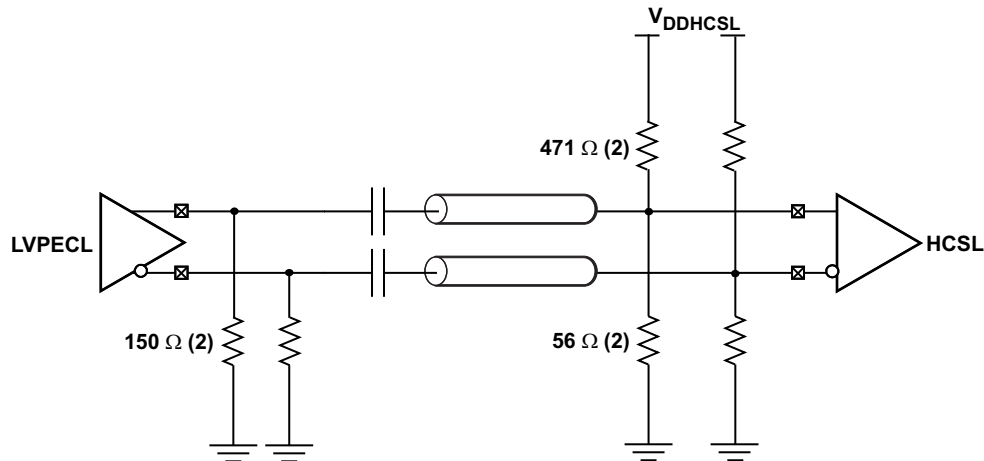

$C_{IN} = 8 \text{ pF}$ (typical), 10 pF (maximum); see [Electrical Characteristics](#).

Figure 9. Interfacing Between LVPECL and HCSL

9.5 Programming

[Table 2](#) and [Table 3](#) list the pin controls and pin configurations of the CDCM9102 output. [Table 4](#) lists the device reset.

9.5.1 Device Configuration

Table 2. CDCM9102 Pin Control of Output Enable

OE (Pin 7)	MODE	DEVICE CORE	OUTPUT
0	Power down	Power down	Hi-Z
1	Normal	Active	Active

Table 3. CDCM9102 Pin Configuration of Output Type

CONTROL PINS		OUTPUT MODE
OS1 (Pin 10)	OS0 (Pin 11)	
0	0	LVC MOS, OSCOUT = OFF
0	1	LVDS, OSCOUT = OFF
1	0	LVPECL, OSCOUT = OFF
1	1	LVPECL, OSCOUT = ON

Table 4. CDCM9102 Device Reset

RESET (Pin 12)	OPERATING MODE	DEVICE OUTPUTS
0	Device reset	Hi-Z
0 → 1	Clock generator calibration	Hi-Z
1	Normal	Active

10 Application and Implementation

NOTE

Information in the following applications sections is not part of the TI component specification, and TI does not warrant its accuracy or completeness. TI's customers are responsible for determining suitability of components for their purposes. Customers should validate and test their design implementation to confirm system functionality.

10.1 Application Information

10.1.1 Start-Up Time Estimation

The CDCM9102 contains a low-noise clock generator that calibrates to an optimal operating point at device power up. To ensure proper device operation, the oscillator must be stable before the low-noise clock generator calibration procedure. Quartz-based oscillators can take up to 2 ms to stabilize; therefore, TI recommends that the application ensure that the RESET pin is de-asserted at least 5 ms after the power supply has finished ramping. This can be accomplished by controlling the RESET pin directly, or by applying a 47-nF capacitor to ground on the RESET pin (this provides a delay because the RESET pin includes a 150-kΩ pullup resistor).

The CDCM9102 start-up time can be estimated based on parameters defined in [Table 5](#) and graphically shown in [Figure 10](#).

Table 5. CDCM9102 Start-Up Time Dependencies

PARAMETER	DEFINITION	DESCRIPTION	FORMULA OR METHOD OF DETERMINATION
t_{REF}	Reference clock period	The reciprocal of the applied reference frequency in seconds	$t_{REF} = \frac{1}{f_{REF}} = 0.04 \mu s$
t_{pul}	Power-up time (low limit)	Power-supply rise time to low limit of power-on-reset trip point	Time required for power supply to ramp to 2.27 V
t_{puh}	Power-up time (high limit)	Power supply rise time to high limit of power-on-reset trip point	Time required for power supply to ramp to 2.64 V
t_{rsu}	Reference start-up time	After POR releases, the Colpitts oscillator is enabled. This start-up time is required for the oscillator to generate the requisite signal levels for the delay block to be clocked by the reference input.	500 μs best case and 800 μs worst case (for a crystal input)
t_{delay}	Delay time	Internal delay time generated from the reference clock. This delay provides time for the reference oscillator to stabilize.	$t_{delay} = 16,384 \times t_{REF} = 655 \mu s$
t_{VCO_CAL}	VCO calibration time	VCO calibration time generated from the reference clock. This process selects the operating point for the VCO based on the PLL settings.	$t_{VCO_CAL} = 550 \times t_{REF} = 22 \mu s$
t_{PLL_LOCK}	PLL lock time	Time required for PLL to lock within ± 10 ppm of f_{REF}	The PLL settles in 12.5 μs

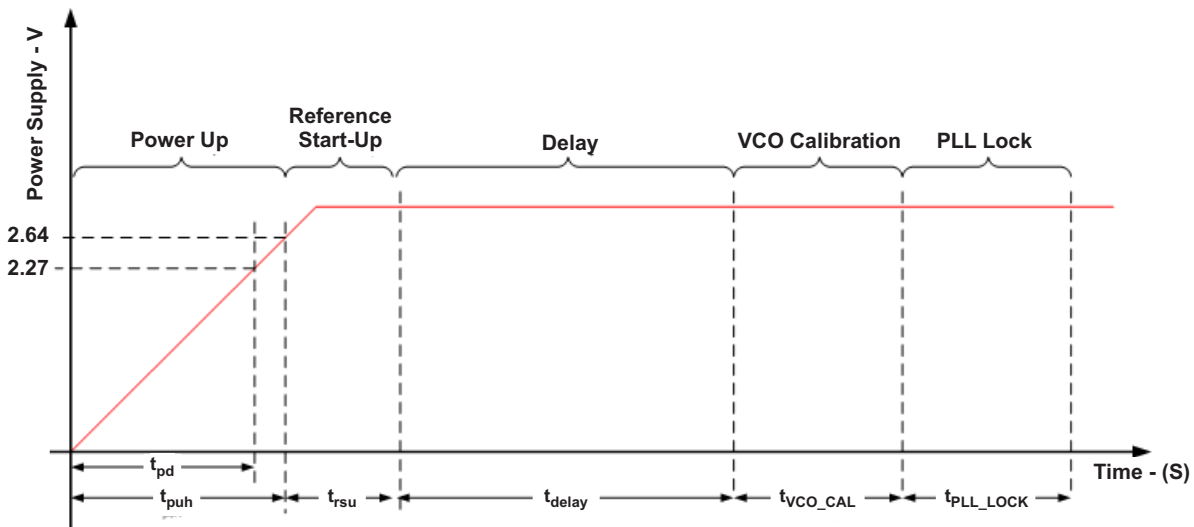

Figure 10. CDCM9102 Start-Up Time Dependencies

The CDCM9102 start-up time limits, t_{MAX} and t_{MIN} , can now be calculated with Equation 2 and Equation 3.

$$t_{MAX} = t_{puh} + t_{rsu} + t_{delay} + t_{VCO_CAL} + t_{PLL_LOCK} \tag{2}$$

$$t_{MIN} = t_{pul} + t_{rsu} + t_{delay} + t_{VCO_CAL} + t_{PLL_LOCK} \tag{3}$$

10.1.2 Output Termination

The CDCM9102 is a 3.3-V clock driver which has the following options for the output type: LVPECL, LVDS, and LVCMOS.

10.1.3 LVPECL Termination

The CDCM9102 is an open emitter for LVPECL outputs. Therefore, proper biasing and termination is required to ensure correct operation of the device and to optimize signal integrity. The proper termination for LVPECL is 50 Ω to (V_{cc}-2) V but this DC voltage is not readily available on a board. Thus a Thevenin's equivalent circuit is worked out for the LVPECL termination in both direct-coupled (DC) and AC-coupled cases, as shown in Figure 11 and Figure 12. TI recommends placing all resistive components close to either the driver end or the receiver end. If the supply voltages of the driver and receiver are different, AC coupling is required.

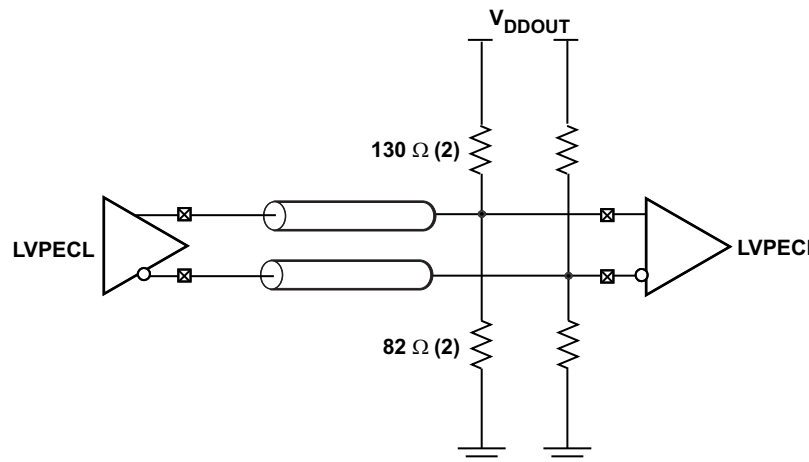

Figure 11. LVPECL Output Termination (DC-Coupled)

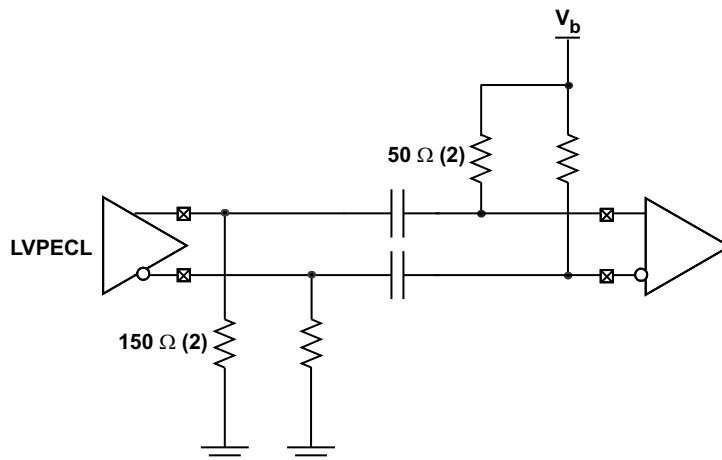

Figure 12. LVPECL Output Termination (AC-Coupled)

10.1.4 LVDS Termination

The proper LVDS termination for signal integrity over two 50-Ω lines is 100 Ω between the outputs on the receiver end. Either a direct-coupled (dc) termination or ac-coupled termination can be used for LVDS outputs, as shown in Figure 13 and Figure 14. TI recommends placing all resistive components close to either the driver end or the receiver end. If the supply voltages of the driver and receiver are different, AC coupling is required.

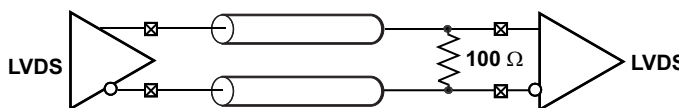

Figure 13. LVDS Output Termination (DC Coupled)

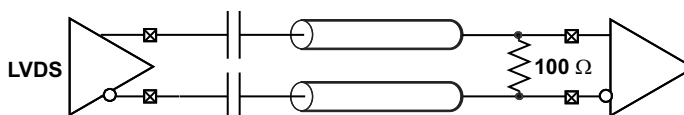

Figure 14. LVDS Output Termination (AC Coupling)

10.1.5 LVCMOS Termination

Series termination is a common method to maintain the signal integrity for LVCMOS drivers, if connected to a receiver with a high-impedance input. For series termination, a series resistor, R_s , is placed close to the driver, as shown in Figure 15. The sum of the driver impedance and R_s should be close to the transmission-line impedance, which is usually 50 Ω. Because the LVCMOS driver in the CDCM9102 has an impedance of 30 Ω, TI recommends R_s be 22 Ω to maintain proper signal integrity.

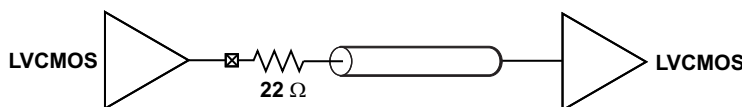

Figure 15. LVCMOS Output Termination

10.1.6 PCI Express Applications

Texas Instruments offers a complete clock solution for PCI Express applications. The CDCUN1208LP can be used to fan out reference clock generated by the CDCM9102 as shown in Figure 16.

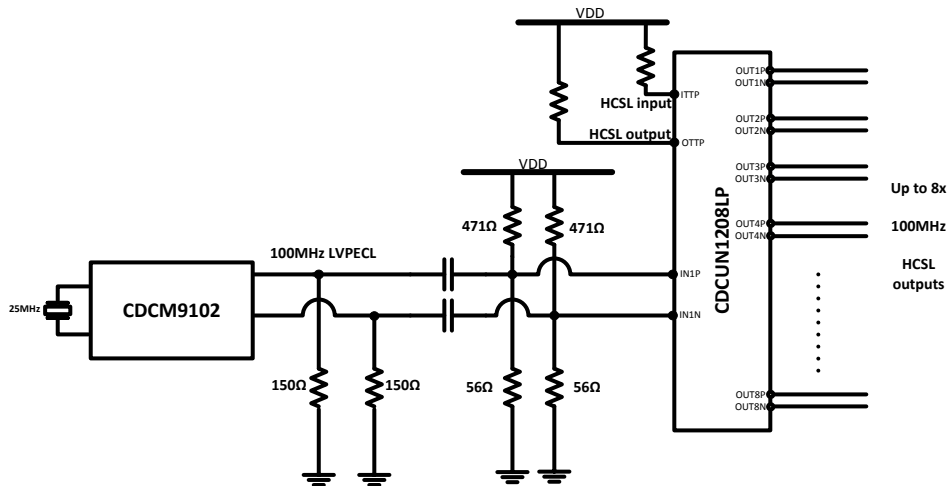

Figure 16. Clock Solution for PCIe Express Applications

10.2 Typical Application

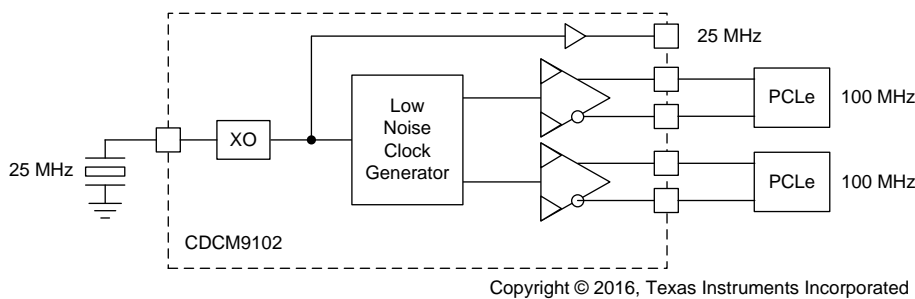

Figure 17. CDCM9102 Typical Application Example

10.2.1 Design Requirements

Consider a typical wired communications application, like a top-of-rack switch, which needs to clock PCI Express Gen 2 or 3 PHYs. For such asynchronous systems, the reference input can be a crystal. In such systems, the clocks are expected to be available upon power up without the need for any device-level programming. An example of clock input and output requirements is shown below:

- Clock Input:
 - 25-MHz crystal
- Clock Outputs:
 - 2x 100 MHz clock for PCI Express Gen 3 (8 GT/s), LVPECL

See [Detailed Design Procedure](#) for how to generate the required output frequencies for this application using the CDCM9102.

Typical Application (continued)

10.2.2 Detailed Design Procedure

Design of all aspects of the CDCM61004 is quite involved and software support is available to assist in part selection and phase noise simulation. This design procedure will give a quick outline of the process.

1. Device Selection

- The first step is to calculate the VCO frequency given the required output frequency. The device must be able to produce the VCO frequency that can be divided down to the required output frequency.
- The WEBENCH Clock Architect Tool from TI will aid in the selection of the right device that meets the customer's output frequencies and format requirements.

2. Device Configuration

- The WEBENCH Clock Architect Tool attempts to maximize the phase detector frequency, use smallest dividers, and maximizes PLL bandwidth.

10.2.2.1 Device Selection

Use the WEBENCH Clock Architect Tool. Enter the required frequencies and formats into the tool. To use this device, find a solution using the CDCM9102.

10.2.2.1.1 Calculation Using LCM

In this example, the valid VCO frequency for CDCM9102 is 1.8 GHz.

10.2.2.2 Device Configuration

For this example, when using the WEBENCH Clock Architect Tool, the reference would have been manually entered as 25 MHz according to input frequency requirements. Enter the desired output frequencies and click on Generate Solutions. Select CDCM9102 from the solution list.

From the simulation page of the WEBENCH Clock Architect Tool, it can be seen that to maximize phase detector frequencies, the N divider is set to 24 and prescaler divider is set to 3. This results in a VCO frequency of 1.8 GHz. The output divider is set to 6. At this point the design meets all input and output frequency requirements and simulate performance on the clock outputs. [Figure 18](#) shows the typical phase noise plot of the 100 MHz LVPECL output.

Typical Application (continued)

10.2.3 Application Curve

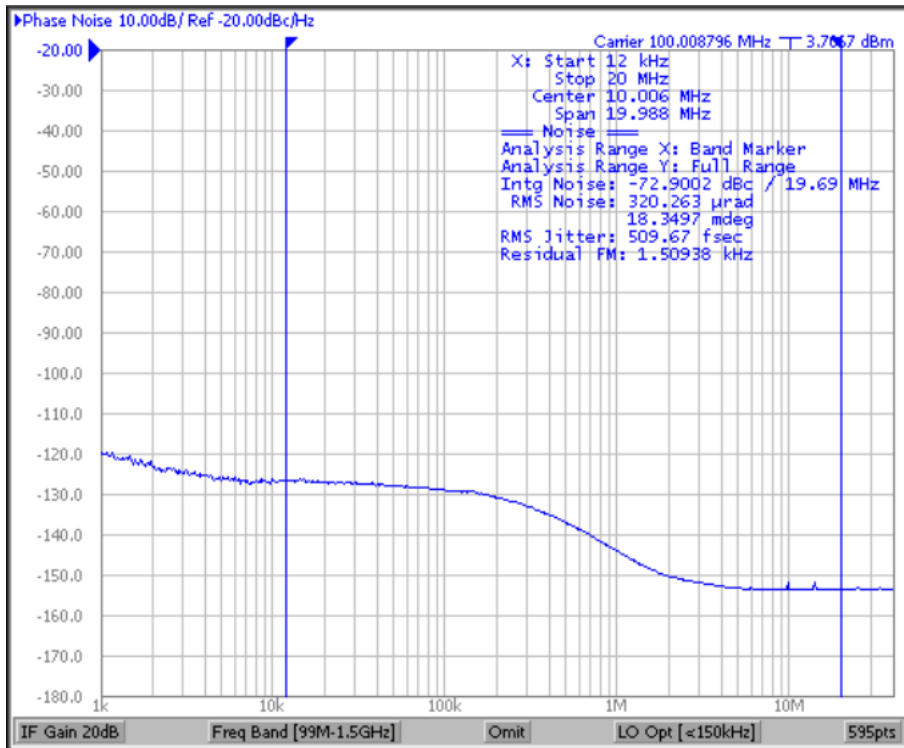

Figure 18. Typical Phase Noise Plot of 100 MHz LVPECL Output

11 Power Supply Recommendations

$T_A = -40^{\circ}\text{C}$ to 85°C , $V_{DDx} = 3.3\text{ V}$, $OE = 1$, values represent cumulative current/power on all V_{DDx} pins.

Table 6. Device Current Consumption

BLOCK	CONDITION	CURRENT (mA)	DEVICE POWER (mW)	EXTERNAL RESISTOR POWER (mW)
Entire device, core current		85	280	
Output Buffers	LVPECL	28	42.4	50
	LVDS	20	66	
	LVC MOS	$V \times f_{out} \times (C_L + 20 \times 10^{-12}) \times 10^3$	$V^2 \times f_{out} \times (C_L + 20 \times 10^{-12}) \times 10^3$	

11.1 Thermal Management

To ensure optimal performance and reliability, good thermal design practices are important when using the CDCM9102. Die temperature should be limited to a maximum of 125°C . That is, as an estimate, T_A (ambient temperature) plus device power consumption times $R_{\theta JA}$ should not exceed 125°C .

The device package has an exposed pad that provides the primary heat removal path as well as an electrical grounding to the printed circuit board (PCB). To maximize the removal of heat from the package, a thermal landing pattern including multiple vias to a ground plane must be incorporated on the PCB within the footprint of the package. The exposed pad must be soldered down to ensure adequate heat conduction out of the package. A recommended land and via pattern is shown in Figure 19.

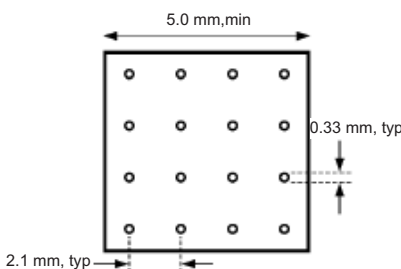

Figure 19. Recommended PCB Layout for CDCM9102

11.2 Power Supply Filtering

PLL-based frequency synthesizers are very sensitive to noise on the power supply, which can dramatically increase the jitter of the PLL. This is especially true for analog-based PLLs. Thus, it is essential to reduce noise from the system power supply, especially when jitter/phase noise is very critical to applications. A PLL has attenuated jitter due to power supply noise at frequencies beyond the PLL bandwidth due to attenuation by the loop response.

Filter capacitors are used to eliminate the low-frequency noise from the power supply, where the bypass capacitors provide the very low-impedance path for high-frequency noise and guard the power supply system against induced fluctuations. The bypass capacitors also provide a source of instantaneous current as required by the device output stages. Therefore, bypass capacitors must have low ESR. To properly use the bypass capacitors, they must be placed very close to the power supply pins and must be laid out with short loops to minimize inductance.

Figure 20 shows a general recommendation for decoupling the power supply. The CDCM9102 power supplies fall into one of two categories: analog supplies (V_{DD3} , V_{DD4} , and V_{DD5}), and input/output supplies (V_{DD1} , V_{DD2} , and V_{DD6}). Short the analog supplies together to form the analog supply node; likewise, short the input/output supplies together to form the I/O supply node. Isolate the analog node from the PCB power supply and I/O node by inserting a ferrite bead. This helps isolate the high-frequency switching noises generated by the clock drivers and I/O from the sensitive analog supply node. Choosing an appropriate ferrite bead with low dc resistance is important, as it is imperative to maintain a voltage at the power-supply pin of the CDCM9102 that is over the minimum voltage needed for its proper operation.

Power Supply Filtering (continued)

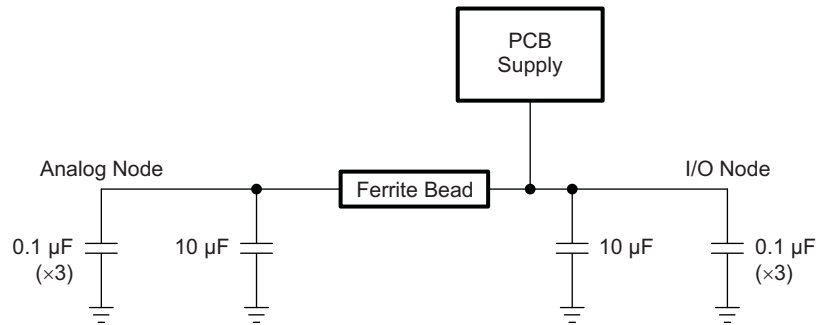

Figure 20. CDCM9102 Power Supply Decoupling – Power Pin Bypass Concept

12 Layout

12.1 Layout Guidelines

The CDCM9102 is a high-performance device; therefore, pay careful attention to device configuration and printed-circuit board layout with respect to power consumption. Observing good thermal layout practices enables the thermal pad on the backside of the 32-pin VQFN package to provide a good thermal path between the die contained within the package and the ambient air. This thermal pad also serves as the ground connection the device; therefore, a low inductance connection to the ground plane is essential.

12.2 Layout Example

Figure 21 shows a general recommendation of PCB layout with the CDCM9102 that ensures good system-level thermal reliability.

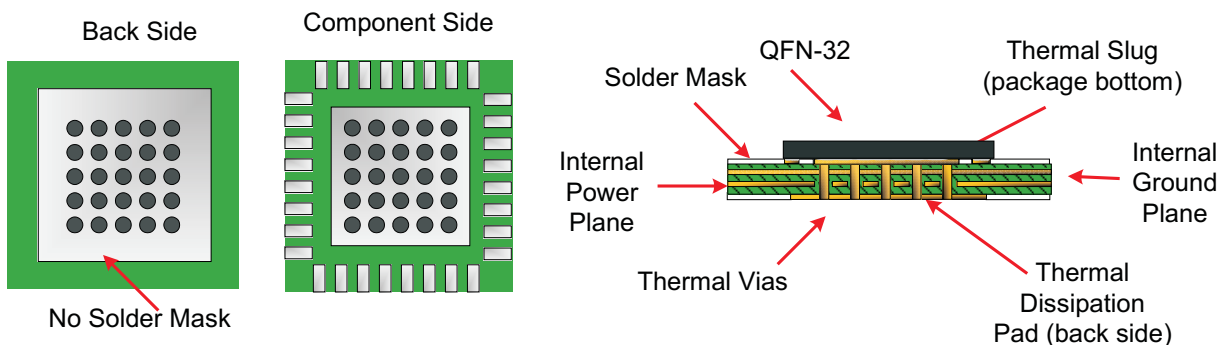

Figure 21. Recommended PCB Layout

13 器件和文档支持

13.1 社区资源

The following links connect to TI community resources. Linked contents are provided "AS IS" by the respective contributors. They do not constitute TI specifications and do not necessarily reflect TI's views; see TI's [Terms of Use](#).

TI E2E™ Online Community *TI's Engineer-to-Engineer (E2E) Community*. Created to foster collaboration among engineers. At e2e.ti.com, you can ask questions, share knowledge, explore ideas and help solve problems with fellow engineers.

Design Support *TI's Design Support* Quickly find helpful E2E forums along with design support tools and contact information for technical support.

13.2 商标

E2E is a trademark of Texas Instruments.

PCI Express is a trademark of PCI-SIG.

All other trademarks are the property of their respective owners.

13.3 静电放电警告



这些装置包含有限的内置 ESD 保护。存储或装卸时，应将导线一起截短或将装置放置于导电泡棉中，以防止 MOS 门极遭受静电损伤。

13.4 Glossary

[SLYZ022](#) — *TI Glossary*.

This glossary lists and explains terms, acronyms, and definitions.

14 机械、封装和可订购信息

以下页中包括机械、封装和可订购信息。这些信息是针对指定器件可提供的最新数据。这些数据会在无通知且不对本文档进行修订的情况下发生改变。要获得这份数据表的浏览器版本，请查阅左侧的导航栏。

重要声明

德州仪器(TI)及其下属子公司有权根据 JESD46 最新标准,对所提供的产品和服务进行更正、修改、增强、改进或其它更改,并有权根据 JESD48 最新标准中止提供任何产品和服务。客户在下订单前应获取最新的相关信息,并验证这些信息是否完整且是最新的。所有产品的销售都遵循在订单确认时所提供的TI 销售条款与条件。

TI 保证其所销售的组件的性能符合产品销售时 TI 半导体产品销售条件与条款的适用规范。仅在 TI 保证的范围内,且 TI 认为有必要时才会使用测试或其它质量控制技术。除非适用法律做出了硬性规定,否则没有必要对每种组件的所有参数进行测试。

TI 对应用帮助或客户产品设计不承担任何义务。客户应对其使用 TI 组件的产品和应用自行负责。为尽量减小与客户产品和应用相关的风险,客户应提供充分的设计与操作安全措施。

TI 不对任何 TI 专利权、版权、屏蔽作品权或其它与使用了 TI 组件或服务的组合设备、机器或流程相关的 TI 知识产权中授予的直接或隐含权限作出任何保证或解释。TI 所发布的与第三方产品或服务有关的信息,不能构成从 TI 获得使用这些产品或服务的许可、授权、或认可。使用此类信息可能需要获得第三方的专利权或其它知识产权方面的许可,或是 TI 的专利权或其它知识产权方面的许可。

对于 TI 的产品手册或数据表中 TI 信息的重要部分,仅在没有对内容进行任何篡改且带有相关授权、条件、限制和声明的情况下才允许进行复制。TI 对此类篡改过的文件不承担任何责任或义务。复制第三方的信息可能需要服从额外的限制条件。

在转售 TI 组件或服务时,如果对该组件或服务参数的陈述与 TI 标明的参数相比存在差异或虚假成分,则会失去相关 TI 组件或服务的所有明示或暗示授权,且这是不正当的、欺诈性商业行为。TI 对任何此类虚假陈述均不承担任何责任或义务。

客户认可并同意,尽管任何应用相关信息或支持仍可能由 TI 提供,但他们将独立负责满足与其产品及其在应用中使用的 TI 产品相关的所有法律、法规和安全相关要求。客户声明并同意,他们具备制定与实施安全措施所需的全部专业技术和知识,可预见故障的危险后果、监测故障及其后果、降低有可能造成人身伤害的故障的发生机率并采取适当的补救措施。客户将全额赔偿因在此类安全关键应用中使用任何 TI 组件而对 TI 及其代理造成的任何损失。

在某些场合中,为了推进安全相关应用有可能对 TI 组件进行特别的促销。TI 的目标是利用此类组件帮助客户设计和创立其特有的可满足适用的功能安全性标准和要求的终端产品解决方案。尽管如此,此类组件仍然服从这些条款。

TI 组件未获得用于 FDA Class III (或类似的生命攸关医疗设备)的授权许可,除非各方授权官员已经达成了专门管控此类使用的特别协议。



只有那些 TI 特别注明属于军用等级或“增强型塑料”的 TI 组件才是设计或专门用于军事/航空应用或环境的。购买者认可并同意,对并非指定面向军事或航空航天用途的 TI 组件进行军事或航空航天方面的应用,其风险由客户单独承担,并且由客户独立负责满足与此类使用相关的所有法律和法规要求。

TI 已明确指定符合 ISO/TS16949 要求的产品,这些产品主要用于汽车。在任何情况下,因使用非指定产品而无法达到 ISO/TS16949 要求, TI 不承担任何责任。

	产品		应用
数字音频	www.ti.com.cn/audio	通信与电信	www.ti.com.cn/telecom
放大器和线性器件	www.ti.com.cn/amplifiers	计算机及周边	www.ti.com.cn/computer
数据转换器	www.ti.com.cn/dataconverters	消费电子	www.ti.com.cn/consumer-apps
DLP® 产品	www.dlp.com	能源	www.ti.com.cn/energy
DSP - 数字信号处理器	www.ti.com.cn/dsp	工业应用	www.ti.com.cn/industrial
时钟和计时器	www.ti.com.cn/clockandtimers	医疗电子	www.ti.com.cn/medical
接口	www.ti.com.cn/interface	安防应用	www.ti.com.cn/security
逻辑	www.ti.com.cn/logic	汽车电子	www.ti.com.cn/automotive
电源管理	www.ti.com.cn/power	视频和影像	www.ti.com.cn/video
微控制器 (MCU)	www.ti.com.cn/microcontrollers		
RFID 系统	www.ti.com.cn/rfidsys		
OMAP应用处理器	www.ti.com/omap		
无线连通性	www.ti.com.cn/wirelessconnectivity	德州仪器在线技术支持社区	www.deyisupport.com

邮寄地址: 上海市浦东新区世纪大道1568号, 中建大厦32楼邮政编码: 200122
Copyright © 2016, 德州仪器半导体技术(上海)有限公司

PACKAGING INFORMATION

Orderable Device	Status (1)	Package Type	Package Drawing	Pins	Package Qty	Eco Plan (2)	Lead finish/ Ball material (6)	MSL Peak Temp (3)	Op Temp (°C)	Device Marking (4/5)	Samples
CDCM9102RHBR	ACTIVE	VQFN	RHB	32	3000	RoHS & Green	NIPDAU	Level-2-260C-1 YEAR	-40 to 85	CDCM 9102	
CDCM9102RHBT	ACTIVE	VQFN	RHB	32	250	RoHS & Green	NIPDAU	Level-2-260C-1 YEAR	-40 to 85	CDCM 9102	

(1) The marketing status values are defined as follows:

ACTIVE: Product device recommended for new designs.

LIFEBUY: TI has announced that the device will be discontinued, and a lifetime-buy period is in effect.

NRND: Not recommended for new designs. Device is in production to support existing customers, but TI does not recommend using this part in a new design.

PREVIEW: Device has been announced but is not in production. Samples may or may not be available.

OBSOLETE: TI has discontinued the production of the device.

(2) **RoHS:** TI defines "RoHS" to mean semiconductor products that are compliant with the current EU RoHS requirements for all 10 RoHS substances, including the requirement that RoHS substance do not exceed 0.1% by weight in homogeneous materials. Where designed to be soldered at high temperatures, "RoHS" products are suitable for use in specified lead-free processes. TI may reference these types of products as "Pb-Free".

RoHS Exempt: TI defines "RoHS Exempt" to mean products that contain lead but are compliant with EU RoHS pursuant to a specific EU RoHS exemption.

Green: TI defines "Green" to mean the content of Chlorine (Cl) and Bromine (Br) based flame retardants meet JS709B low halogen requirements of <=1000ppm threshold. Antimony trioxide based flame retardants must also meet the <=1000ppm threshold requirement.

(3) MSL, Peak Temp. - The Moisture Sensitivity Level rating according to the JEDEC industry standard classifications, and peak solder temperature.

(4) There may be additional marking, which relates to the logo, the lot trace code information, or the environmental category on the device.

(5) Multiple Device Markings will be inside parentheses. Only one Device Marking contained in parentheses and separated by a "~" will appear on a device. If a line is indented then it is a continuation of the previous line and the two combined represent the entire Device Marking for that device.

(6) Lead finish/Ball material - Orderable Devices may have multiple material finish options. Finish options are separated by a vertical ruled line. Lead finish/Ball material values may wrap to two lines if the finish value exceeds the maximum column width.

Important Information and Disclaimer:The information provided on this page represents TI's knowledge and belief as of the date that it is provided. TI bases its knowledge and belief on information provided by third parties, and makes no representation or warranty as to the accuracy of such information. Efforts are underway to better integrate information from third parties. TI has taken and continues to take reasonable steps to provide representative and accurate information but may not have conducted destructive testing or chemical analysis on incoming materials and chemicals. TI and TI suppliers consider certain information to be proprietary, and thus CAS numbers and other limited information may not be available for release.

In no event shall TI's liability arising out of such information exceed the total purchase price of the TI part(s) at issue in this document sold by TI to Customer on an annual basis.

TAPE AND REEL INFORMATION

QUADRANT ASSIGNMENTS FOR PIN 1 ORIENTATION IN TAPE

*All dimensions are nominal

Device	Package Type	Package Drawing	Pins	SPQ	Reel Diameter (mm)	Reel Width W1 (mm)	A0 (mm)	B0 (mm)	K0 (mm)	P1 (mm)	W (mm)	Pin1 Quadrant
CDCM9102RHBR	VQFN	RHB	32	3000	330.0	12.4	5.3	5.3	1.5	8.0	12.0	Q2
CDCM9102RHBT	VQFN	RHB	32	250	180.0	12.4	5.3	5.3	1.5	8.0	12.0	Q2

TAPE AND REEL BOX DIMENSIONS

*All dimensions are nominal

Device	Package Type	Package Drawing	Pins	SPQ	Length (mm)	Width (mm)	Height (mm)
CDCM9102RHBR	VQFN	RHB	32	3000	853.0	449.0	35.0
CDCM9102RHBT	VQFN	RHB	32	250	210.0	185.0	35.0

GENERIC PACKAGE VIEW

RHB 32

VQFN - 1 mm max height

5 x 5, 0.5 mm pitch

PLASTIC QUAD FLATPACK - NO LEAD

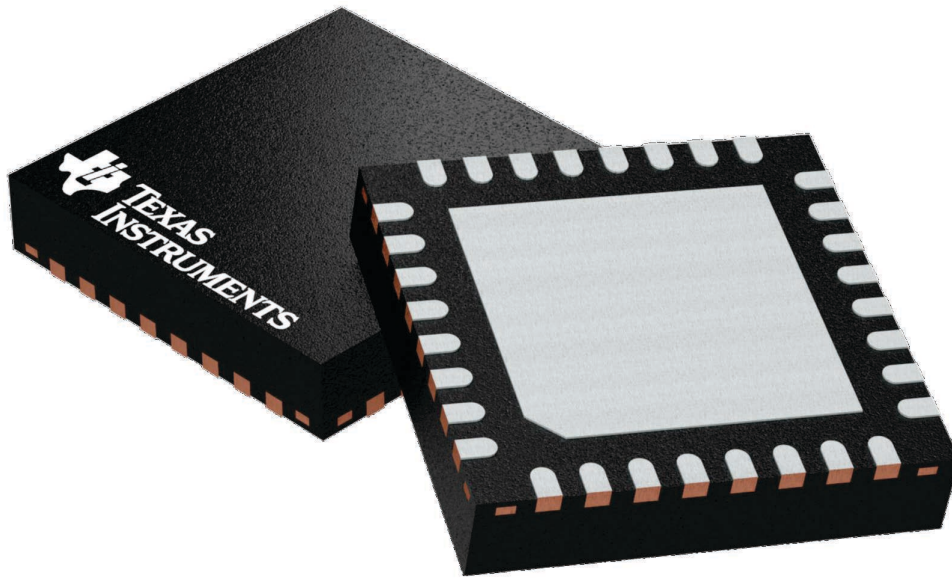

Images above are just a representation of the package family, actual package may vary.
Refer to the product data sheet for package details.

4224745/A

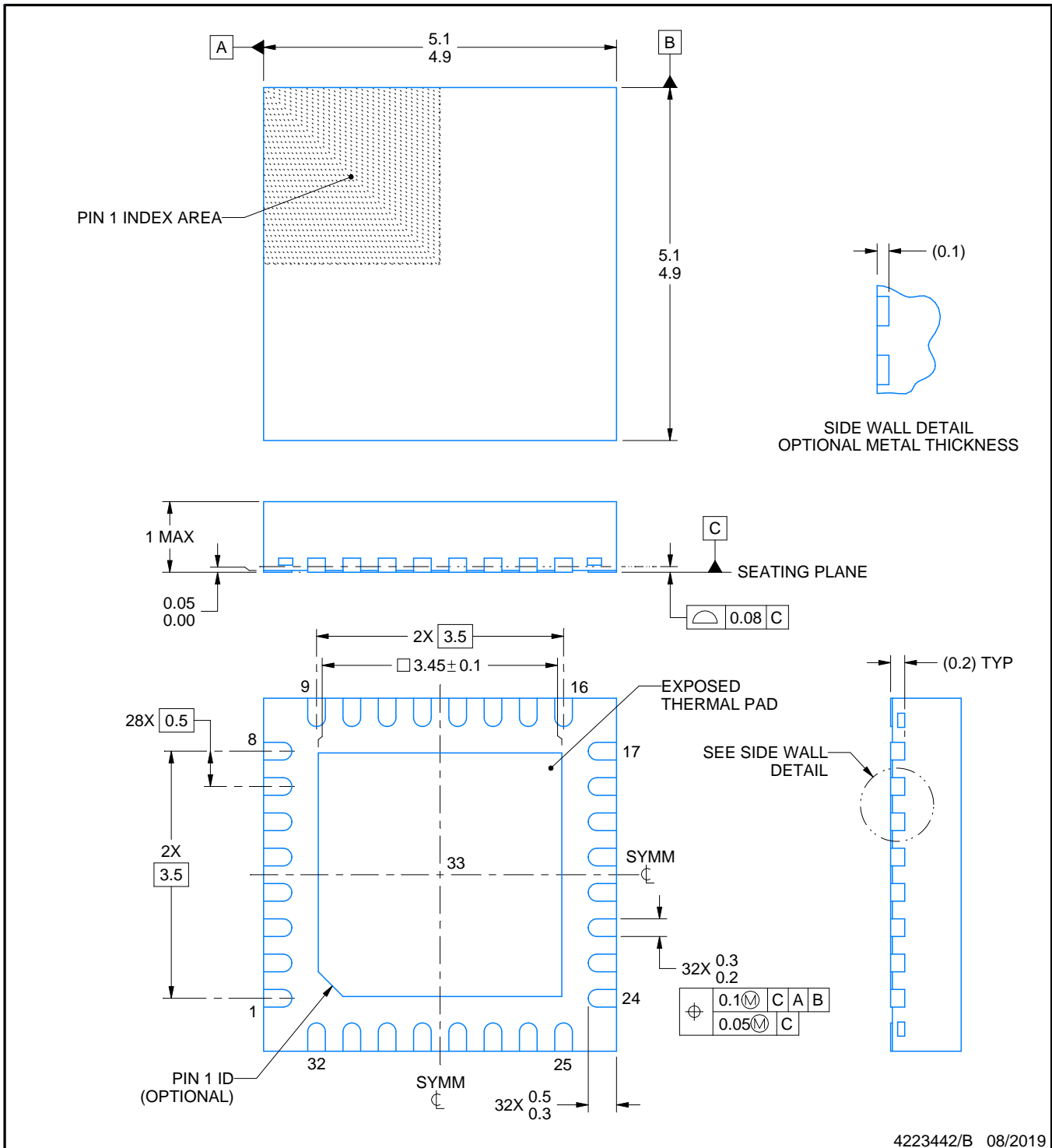
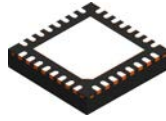

4223442/B 08/2019

NOTES:

1. All linear dimensions are in millimeters. Any dimensions in parenthesis are for reference only. Dimensioning and tolerancing per ASME Y14.5M.
2. This drawing is subject to change without notice.
3. The package thermal pad must be soldered to the printed circuit board for thermal and mechanical performance.

EXAMPLE BOARD LAYOUT

RHB0032E

VQFN - 1 mm max height

PLASTIC QUAD FLATPACK - NO LEAD

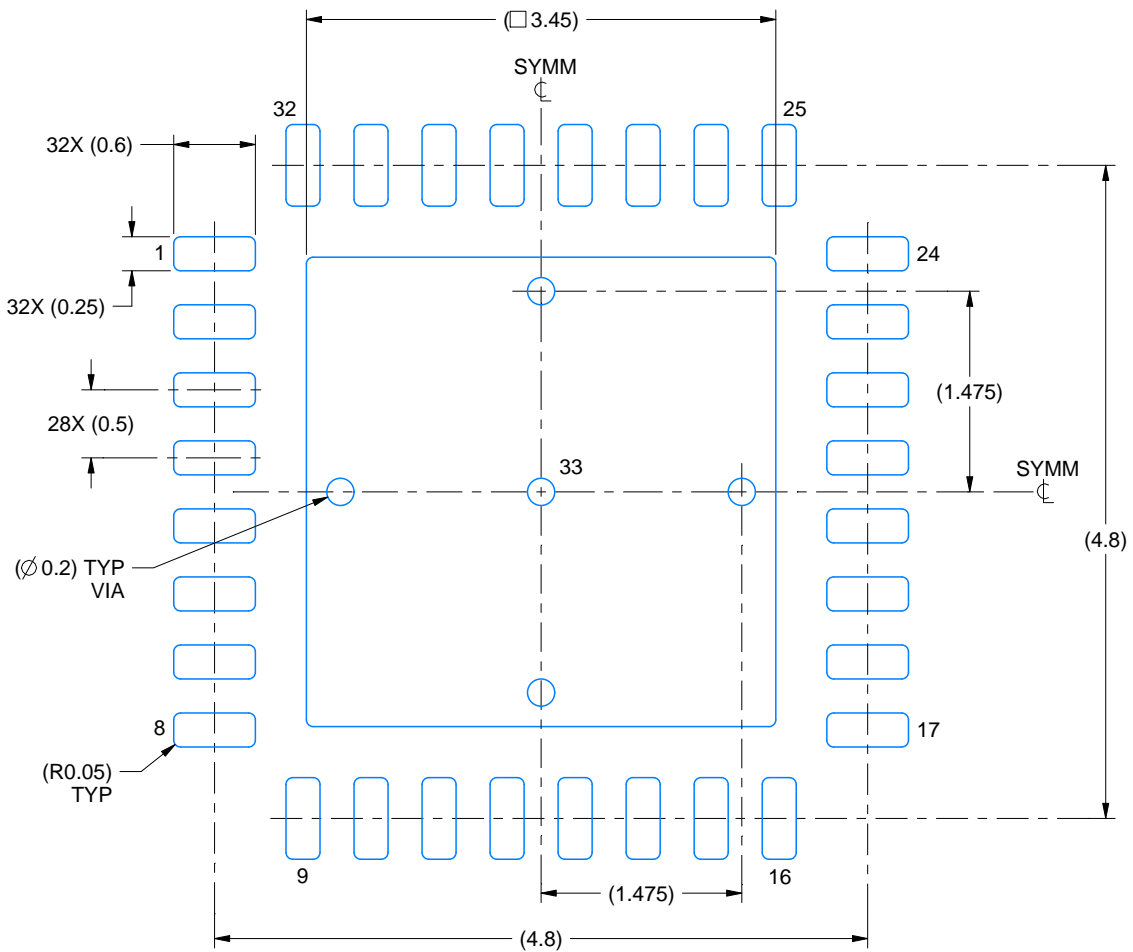

LAND PATTERN EXAMPLE
SCALE:18X

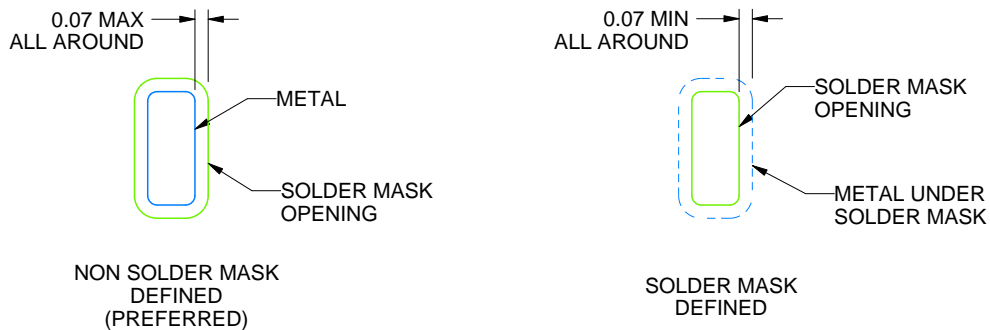

SOLDER MASK DETAILS

4223442/B 08/2019

NOTES: (continued)

- This package is designed to be soldered to a thermal pad on the board. For more information, see Texas Instruments literature number SLUA271 (www.ti.com/lit/slua271).
- Vias are optional depending on application, refer to device data sheet. If any vias are implemented, refer to their locations shown on this view. It is recommended that vias under paste be filled, plugged or tented.

EXAMPLE STENCIL DESIGN

RHB0032E

VQFN - 1 mm max height

PLASTIC QUAD FLATPACK - NO LEAD

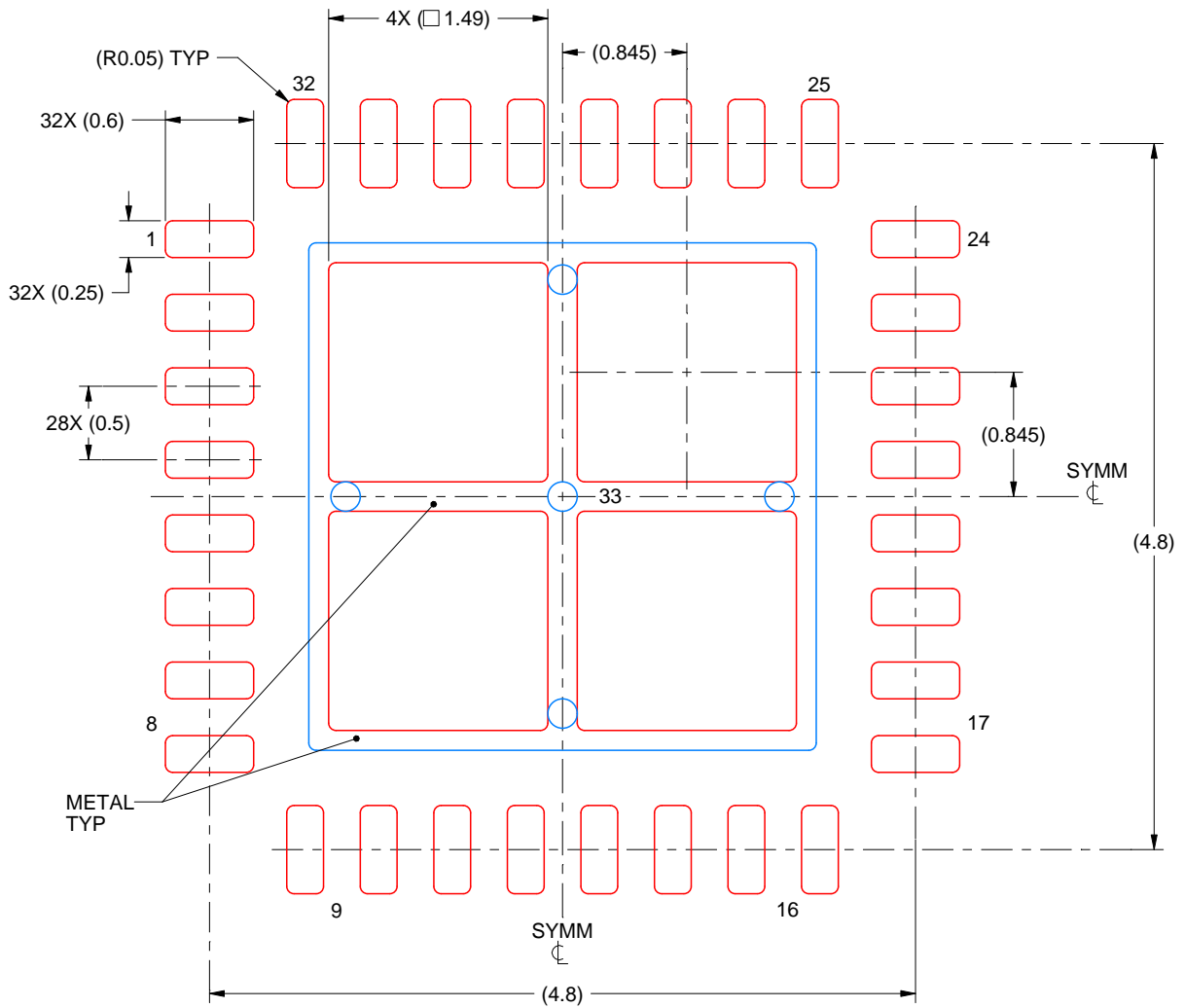

SOLDER PASTE EXAMPLE
BASED ON 0.125 mm THICK STENCIL

EXPOSED PAD 33:
75% PRINTED SOLDER COVERAGE BY AREA UNDER PACKAGE
SCALE:20X

4223442/B 08/2019

NOTES: (continued)

6. Laser cutting apertures with trapezoidal walls and rounded corners may offer better paste release. IPC-7525 may have alternate design recommendations.

重要声明和免责声明

TI 均以“原样”提供技术性及其可靠性数据（包括数据表）、设计资源（包括参考设计）、应用或其他设计建议、网络工具、安全信息和其他资源，不保证其中不含任何瑕疵，且不做任何明示或暗示的担保，包括但不限于对适销性、适合某特定用途或不侵犯任何第三方知识产权的暗示担保。

所述资源可供专业开发人员应用TI 产品进行设计使用。您将对以下行为独自承担全部责任：(1) 针对您的应用选择合适的TI 产品；(2) 设计、验证并测试您的应用；(3) 确保您的应用满足相应标准以及任何其他安全、安保或其他要求。所述资源如有变更，恕不另行通知。TI 对您使用所述资源的授权仅限于开发资源所涉及TI 产品的相关应用。除此之外不得复制或展示所述资源，也不提供其它TI 或任何第三方的知识产权授权许可。如因使用所述资源而产生任何索赔、赔偿、成本、损失及债务等，TI 对此概不负责，并且您须赔偿由此对TI 及其代表造成的损害。

TI 所提供产品均受TI 的销售条款 (<http://www.ti.com.cn/zh-cn/legal/termsofsale.html>) 以及ti.com.cn上或随附TI产品提供的其他可适用条款的约束。TI提供所述资源并不扩展或以其他方式更改TI 针对TI 产品所发布的可适用的担保范围或担保免责声明。

邮寄地址：上海市浦东新区世纪大道 1568 号中建大厦 32 楼，邮政编码：200122

Copyright © 2020 德州仪器半导体技术（上海）有限公司