

ADS7042 超低功耗、超小尺寸、12 位、1MSPS、SAR ADC

1 特性

- 业界第一款具有毫微瓦功耗的逐次逼近寄存器 (SAR) 模数转换器 (ADC):
 - 1MSPS 和 1.8V AVDD 时为 234 μ W
 - 1MSPS 和 3V AVDD 时为 690 μ W
 - 100kSPS 和 3V AVDD 时为 69 μ W
 - 1kSPS 和 3V AVDD 时低于 1 μ W
- 业界最小的 SAR ADC:
 - 采用 X2QFN-8 封装, 封装尺寸为 2.25mm²
- 1MSPS 吞吐量且零延迟
- 宽工作范围:
 - AVDD: 1.65V 到 3.6V
 - DVDD: 1.65V 至 3.6V (与 AVDD 无关)
 - 温度范围: -40°C 至 125°C
- 出色的性能:
 - 12 位分辨率且无丢码 (NMC)
 - 最大 ± 1 最低有效位 (LSB) 的差分非线性 (DNL) 和积分非线性 (INL)
 - 70dB 的信噪比 (SNR) (3V AVDD 时)
 - 80dB 的总谐波失真 (THD) (3V AVDD 时)
- 单极输入范围: 0V 至 AVDD
- 集成偏移校准
- 串行外设接口 (SPI)[™]- 兼容串口: 16MHz
- 符合 JESD8-7A 标准的数字 I/O

2 应用

- 低功耗数据采集
- 电池供电类手持设备
- 液位传感器
- 超声波流量计
- 电机控制
- 可穿戴健身器
- 便携式医疗设备
- 硬盘
- 血糖仪

3 说明

ADS7042 是一款 12 位、1MSPS、模数转换器 (ADC)。该器件支持较宽的模拟输入电压范围 (1.65V 到 3.6V), 并包含一个基于电容且内置采样保持电路的逐次逼近寄存器 (SAR) ADC。串行外设接口 (SPI) 兼容串口由 \overline{CS} 和 SCLK 信号控制。输入信号在 \overline{CS} 下降沿进行采样, SCLK 用于转换和串行数据输出。此器件支持宽范围的数字电源 (1.65V 至 3.6V), 可直接连接到各类主机控制器。ADS7042 符合 JESD8-7A 标准的标称 DVDD 范围 (1.65V 至 1.95V)。

ADS7042 采用 8 引脚微型引线 X2QFN 封装, 额定工作温度范围为 -40°C 至 125°C。此器件尺寸微小且功耗极低, 非常适合空间受限类电池供电应用。

器件信息(1)

部件名称	封装	封装尺寸 (标称值)
ADS7042	X2QFN (8)	1.50mm x 1.50mm
	超薄小外形尺寸封装 (VSSOP)(8)	2.30mm x 2.00mm

(1) 要了解所有可用封装, 请见数据表末尾的可订购产品附录。

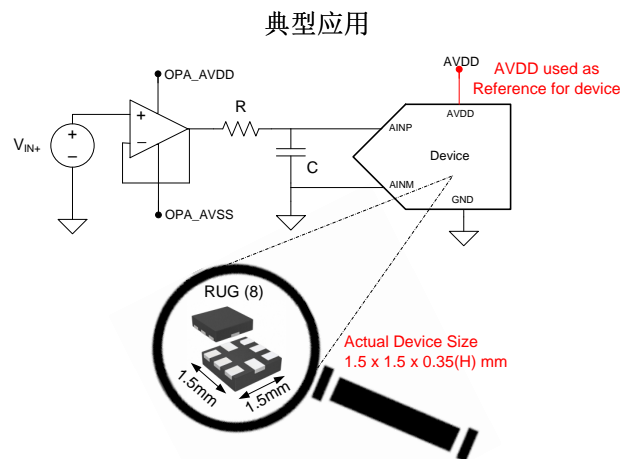

注: ADS7042 比 0805 (2012 公制) SMD 元件小。



目录

1 特性	1	8.4 Device Functional Modes	20
2 应用	1	9 Application and Implementation	23
3 说明	1	9.1 Application Information	23
4 修订历史记录	2	9.2 Typical Applications	23
5 Pin Configuration and Functions	4	10 Power-Supply Recommendations	31
6 Specifications	5	10.1 AVDD and DVDD Supply Recommendations	31
6.1 Absolute Maximum Ratings	5	10.2 Estimating Digital Power Consumption	31
6.2 ESD Ratings	5	10.3 Optimizing Power Consumed by the Device	31
6.3 Recommended Operating Conditions	5	11 Layout	32
6.4 Thermal Information	5	11.1 Layout Guidelines	32
6.5 Electrical Characteristics	6	11.2 Layout Example	32
6.6 Timing Characteristics	8	12 器件和文档支持	33
6.7 Typical Characteristics	9	12.1 文档支持	33
7 Parameter Measurement Information	14	12.2 社区资源	33
7.1 Digital Voltage Levels	14	12.3 商标	33
8 Detailed Description	15	12.4 静电放电警告	33
8.1 Overview	15	12.5 Glossary	33
8.2 Functional Block Diagram	15	13 机械、封装和可订购信息	34
8.3 Feature Description	16		

4 修订历史记录

注：之前版本的页码可能与当前版本有所不同。

Changes from Revision B (February 2015) to Revision C	Page
• Updated Figure 1	8
• Changed <i>Serial Interface</i> section: changed last half of first paragraph, changed Figure 34	19
• Changed Figure 37	22
• 添加了社区资源部分	33

Changes from Revision A (August 2014) to Revision B	Page
• 已更改 宽工作电压范围 特性 要点：已将 AVDD 的值从 1.8V 改为 1.65V	1
• 已更改 宽模拟输入电压范围下限至 1.65V（说明部分第 1 段）	1
• Changed <i>ESD Ratings</i> table to latest standards	5
• Changed AVDD parameter minimum specification in <i>Recommended Operating Conditions</i> table to 1.65 V	5
• Changed E _O parameter uncalibrated test conditions in <i>Electrical Characteristics</i> table	6
• Changed Maximum throughput rate parameter test conditions in <i>Electrical Characteristics</i> table	6
• Changed AVDD parameter minimum specification in <i>Electrical Characteristics</i> table	7
• Changed conditions for <i>Timing Characteristics</i> table: changed range of AVDD and added C _{LOAD} condition	8
• Changed t _{D_CKDO} parameter in <i>Timing Characteristics</i> table	8
• Added f _{SCLK} minimum specification to <i>Timing Characteristics</i> table	8
• Changed titles of Figure 26 to Figure 29	12
• Changed <i>Reference</i> sub-section in <i>Feature Description</i> section	16
• Changed range of second f _{CLK-CAL} parameter description in Table 2	21
• Changed range of second f _{CLK-CAL} parameter description in Table 3	22
• Changed <i>Reference Circuit</i> section in <i>Application Information</i>	25
• Added last two sentences to <i>AVDD and DVDD Supply Recommendations</i> section	31

Changes from Original (June 2014) to Revision A**Page**

• 已更改产品预览数据表	1
• 已添加 TI 参考设计	1

5 Pin Configuration and Functions

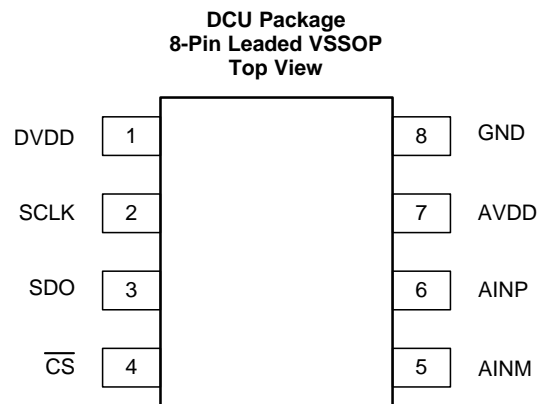
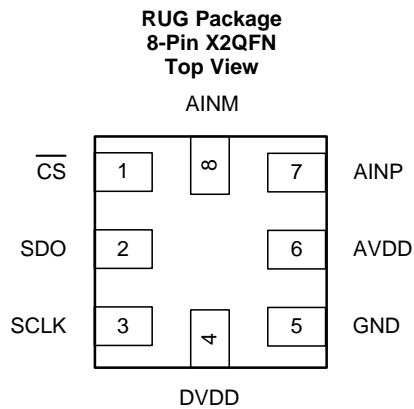

Pin Functions

NAME	PIN NO.		I/O	DESCRIPTION
	RUG	DCU		
AINM	8	5	Analog input	Analog signal input, negative
AINP	7	6	Analog input	Analog signal input, positive
AVDD	6	7	Supply	Analog power-supply input, also provides the reference voltage to the ADC
$\overline{\text{CS}}$	1	4	Digital input	Chip-select signal, active low
DVDD	4	1	Supply	Digital I/O supply voltage
GND	5	8	Supply	Ground for power supply, all analog and digital signals are referred to this pin
SCLK	3	2	Digital input	Serial clock
SDO	2	3	Digital output	Serial data out

6 Specifications

6.1 Absolute Maximum Ratings⁽¹⁾

	MIN	MAX	UNIT
AVDD to GND	−0.3	3.9	V
DVDD to GND	−0.3	3.9	V
AINP to GND	−0.3	AVDD + 0.3	V
AINM to GND	−0.3	0.3	V
Digital input voltage to GND	−0.3	DVDD + 0.3	V
Storage temperature, T _{stg}	−60	150	°C

- (1) Stresses beyond those listed under *Absolute Maximum Ratings* may cause permanent damage to the device. These are stress ratings only, which do not imply functional operation of the device at these or any other conditions beyond those indicated under *Recommended Operating Conditions*. Exposure to absolute-maximum-rated conditions for extended periods may affect device reliability.

6.2 ESD Ratings

		VALUE	UNIT
V _(ESD) Electrostatic discharge	Human body model (HBM), per ANSI/ESDA/JEDEC JS-001 ⁽¹⁾	±2000	V
	Charged device model (CDM), per JEDEC specification JESD22-C101 ⁽²⁾	±1000	

- (1) JEDEC document JEP155 states that 500-V HBM allows safe manufacturing with a standard ESD control process.
(2) JEDEC document JEP157 states that 250-V CDM allows safe manufacturing with a standard ESD control process.

6.3 Recommended Operating Conditions

over operating free-air temperature range (unless otherwise noted)

		MIN	MAX	UNIT
AVDD	Analog supply voltage range	1.65	3.6	V
DVDD	Digital supply voltage range	1.65	3.6	V
T _A	Operating free-air temperature	−40	125	°C

6.4 Thermal Information

THERMAL METRIC ⁽¹⁾		ADS7042		UNIT
		RUG (X2QFN)	DCU (VSSOP)	
		8 PINS	8 PINS	
R _{θJA}	Junction-to-ambient thermal resistance	177.5	235.8	°C/W
R _{θJC(top)}	Junction-to-case (top) thermal resistance	51.5	79.8	°C/W
R _{θJB}	Junction-to-board thermal resistance	76.7	117.6	°C/W
Ψ _{JT}	Junction-to-top characterization parameter	1.0	8.9	°C/W
Ψ _{JB}	Junction-to-board characterization parameter	76.7	116.5	°C/W
R _{θJC(bot)}	Junction-to-case (bottom) thermal resistance	N/A	N/A	°C/W

- (1) For more information about traditional and new thermal metrics, see the *IC Package Thermal Metrics* application report, [SPRA953](#).

6.5 Electrical Characteristics

At $T_A = -40^\circ\text{C}$ to 125°C , $\text{AVDD} = 3\text{ V}$, $\text{DVDD} = 1.65\text{ V}$ to 3.6 V , $f_{\text{SAMPLE}} = 1\text{ MSPS}$, and $V_{\text{AINM}} = 0\text{ V}$, unless otherwise noted.

PARAMETER		TEST CONDITIONS	MIN	TYP	MAX	UNIT	
ANALOG INPUT							
Full-scale input voltage span ⁽¹⁾			0		AVDD	V	
Absolute input voltage range	AINP to GND		-0.1		AVDD + 0.1	V	
	AINM to GND		-0.1		0.1		
C_S	Sampling capacitance			15		pF	
SYSTEM PERFORMANCE							
Resolution				12		Bits	
NMC	No missing codes		12			Bits	
INL	Integral nonlinearity	AVDD = 3 V	-1	±0.7	1	LSB ⁽²⁾	
		AVDD = 1.8 V	-2	±1	2		
DNL	Differential nonlinearity	AVDD = 3 V	-0.99	±0.5	1	LSB	
		AVDD = 1.8 V	-0.99	±0.7	2		
E_O	Offset error	Uncalibrated	AVDD = 1.65 V to 3.6 V		±12	LSB	
		Calibrated ⁽³⁾	AVDD = 3 V	-3	±0.5		3
			AVDD = 1.8 V	-4	±1		4
dV_{OS}/dT	Offset error drift with temperature			5		ppm/°C	
E_G	Gain error	AVDD = 3 V	-0.1	±0.05	0.1	%FS	
		AVDD = 1.8 V	-0.2	±0.1	0.2		
	Gain error drift with temperature			2		ppm/°C	
SAMPLING DYNAMICS							
t_{ACQ}	Acquisition time		200			ns	
	Maximum throughput rate	16-MHz SCLK, AVDD = 1.65 V to 3.6 V			1	MHz	
DYNAMIC CHARACTERISTICS							
SNR	Signal-to-noise ratio ⁽⁴⁾	$f_{IN} = 2\text{ kHz}$, AVDD = 3 V	69	70		dB	
		$f_{IN} = 2\text{ kHz}$, AVDD = 1.8 V		68			
THD	Total harmonic distortion ⁽⁴⁾⁽⁵⁾	$f_{IN} = 2\text{ kHz}$, AVDD = 3 V		-80		dB	
SINAD	Signal-to-noise and distortion ⁽⁴⁾	$f_{IN} = 2\text{ kHz}$, AVDD = 3 V	68	69.5		dB	
		$f_{IN} = 2\text{ kHz}$, AVDD = 1.8 V		67.5			
SFDR	Spurious-free dynamic range ⁽⁴⁾	$f_{IN} = 2\text{ kHz}$, AVDD = 3 V		80		dB	
$BW_{(fp)}$	Full-power bandwidth	At -3 dB, AVDD = 3 V		25		MHz	

(1) Ideal input span; does not include gain or offset error.

(2) LSB means least significant bit.

(3) Refer to the [Offset Calibration](#) section for more details.

(4) All specifications expressed in decibels (dB) refer to the full-scale input (FSR) and are tested with an input signal 0.5 dB below full-scale, unless otherwise specified.

(5) Calculated on the first nine harmonics of the input frequency.

Electrical Characteristics (continued)

At $T_A = -40^{\circ}\text{C}$ to 125°C , $AVDD = 3\text{ V}$, $DVDD = 1.65\text{ V}$ to 3.6 V , $f_{\text{SAMPLE}} = 1\text{ MSPS}$, and $V_{\text{AINM}} = 0\text{ V}$, unless otherwise noted.

PARAMETER		TEST CONDITIONS	MIN	TYP	MAX	UNIT
DIGITAL INPUT/OUTPUT (CMOS Logic Family)						
V_{IH}	High-level input voltage ⁽⁶⁾		0.65 DVDD		DVDD + 0.3	V
V_{IL}	Low-level input voltage ⁽⁶⁾		-0.3		0.35 DVDD	V
V_{OH}	High-level output voltage ⁽⁶⁾	At $I_{\text{source}} = 500\ \mu\text{A}$	0.8 DVDD		DVDD	V
		At $I_{\text{source}} = 2\text{ mA}$	DVDD - 0.45		DVDD	
V_{OL}	Low-level output voltage ⁽⁶⁾	At $I_{\text{sink}} = 500\ \mu\text{A}$	0		0.2 DVDD	V
		At $I_{\text{sink}} = 2\text{ mA}$	0		0.45	
POWER-SUPPLY REQUIREMENTS						
AVDD	Analog supply voltage		1.65	3	3.6	V
DVDD	Digital I/O supply voltage		1.65	3	3.6	V
I_{AVDD}	Analog supply current	At 1 MSPS with AVDD = 3 V			230	μA
		At 100 kSPS with AVDD = 3 V			23	
		At 1 MSPS with AVDD = 1.8 V		130		
P_{D}	Power dissipation	At 1 MSPS with AVDD = 3 V			690	μW
		At 100 kSPS with AVDD = 3 V			69	
		At 1 MSPS with AVDD = 1.8 V		234		

(6) Digital voltage levels comply with the JESD8-7A standard for DVDD from 1.65 V to 1.95 V. See the [Digital Voltage Levels](#) section for more details.

6.6 Timing Characteristics

All specifications are at $T_A = -40^{\circ}\text{C}$ to 125°C , $AVDD = 1.65\text{ V}$ to 3.6 V , $DVDD = 1.65\text{ V}$ to 3.6 V , and C_{LOAD} on SDO = 20 pF , unless otherwise specified.

		MIN	TYP	MAX	UNIT
TIMING SPECIFICATIONS					
$f_{\text{THROUGHPUT}}$	Throughput			1	MSPS
t_{CYCLE}	Cycle time	1			μs
t_{CONV}	Conversion time		$12.5 \times t_{\text{SCLK}} + t_{\text{SU_CSCK}}$		ns
$t_{\text{DV_CSDO}}$	Delay time: $\overline{\text{CS}}$ falling to data enable			10	ns
$t_{\text{D_CKDO}}$	Delay time: SCLK falling to (next) data valid on DOUT, $AVDD = 1.8\text{ V}$ to 3.6 V			30	ns
	Delay time: SCLK falling to (next) data valid on DOUT, $AVDD = 1.65\text{ V}$ to 1.8 V			50	ns
$t_{\text{DZ_CSDO}}$	Delay time: $\overline{\text{CS}}$ rising to DOUT going to 3-state	5			ns
TIMING REQUIREMENTS					
t_{ACQ}	Acquisition time	200			ns
f_{SCLK}	SCLK frequency	0.016		16	MHz
t_{SCLK}	SCLK period	62.5			ns
$t_{\text{PH_CK}}$	SCLK high time	0.45		0.55	t_{SCLK}
$t_{\text{PL_CK}}$	SCLK low time	0.45		0.55	t_{SCLK}
$t_{\text{PH_CS}}$	$\overline{\text{CS}}$ high time	60			ns
$t_{\text{SU_CSCK}}$	Setup time: $\overline{\text{CS}}$ falling to SCLK falling	15			ns
$t_{\text{D_CKCS}}$	Delay time: last SCLK falling to $\overline{\text{CS}}$ rising	10			ns

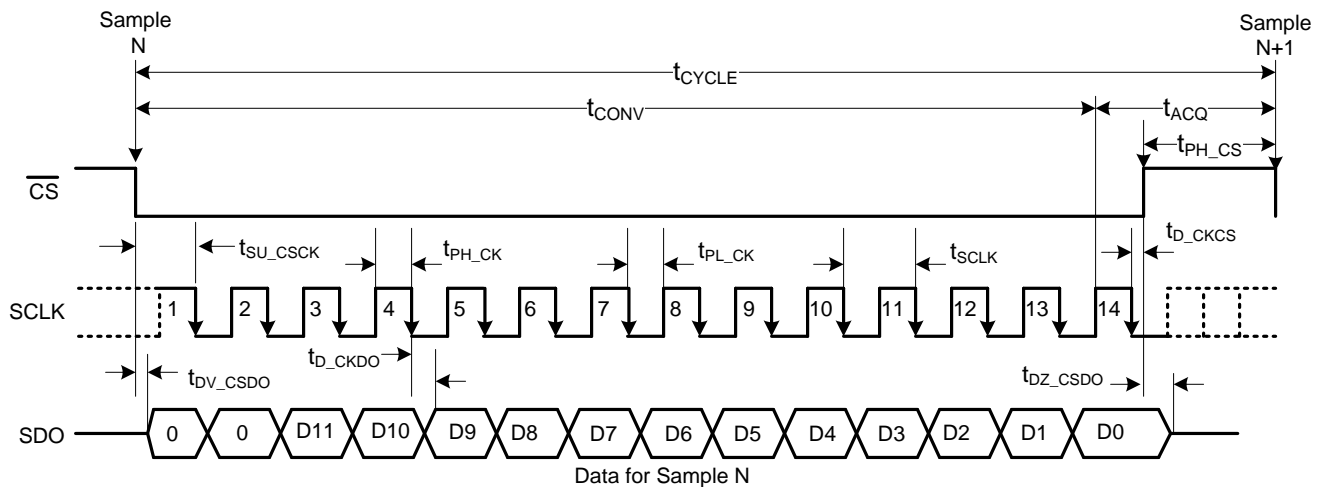

Figure 1. Timing Diagram

6.7 Typical Characteristics

At $T_A = 25^\circ\text{C}$, $AVDD = 3\text{ V}$, $DVDD = 1.8\text{ V}$, and $f_{\text{SAMPLE}} = 1\text{ MSPS}$, unless otherwise noted.

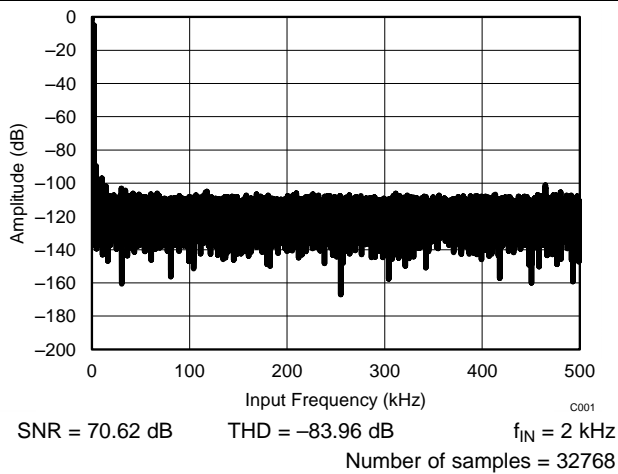

Figure 2. Typical FFT

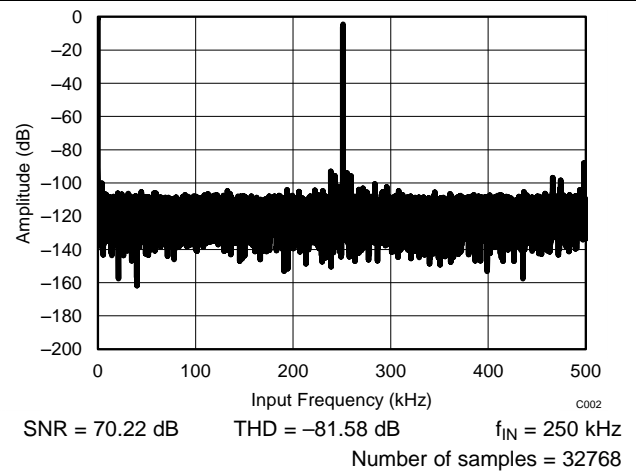

Figure 3. Typical FFT

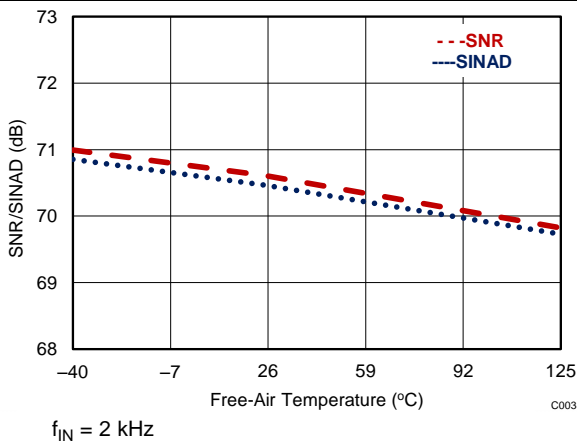

Figure 4. SNR and SINAD vs Temperature

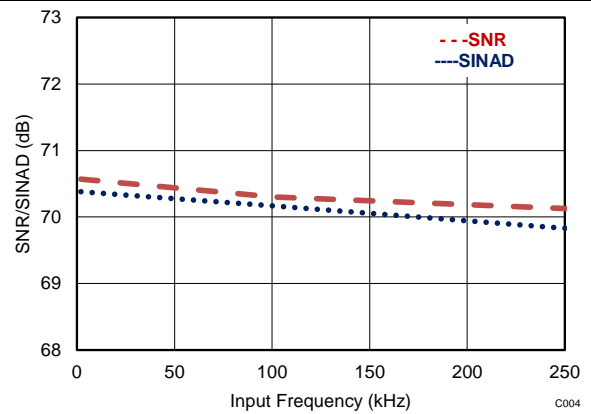

Figure 5. SNR and SINAD vs Input Frequency

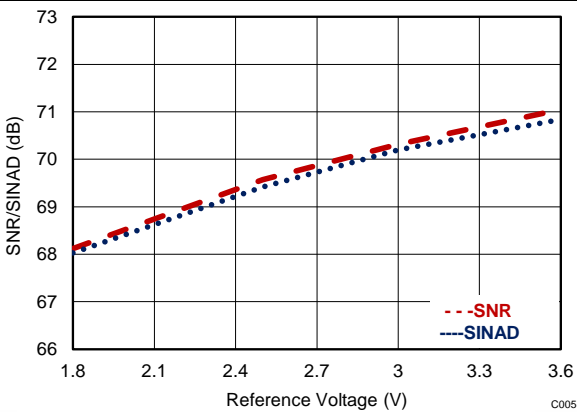

Figure 6. SNR and SINAD vs Reference Voltage (AVDD)

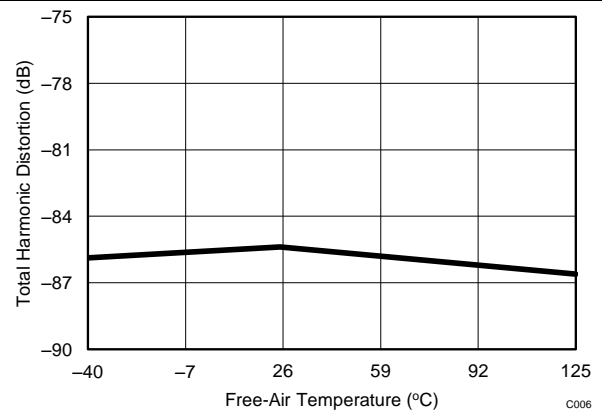

Figure 7. THD vs Free-Air Temperature

Typical Characteristics (continued)

At $T_A = 25^\circ\text{C}$, $AVDD = 3\text{ V}$, $DVDD = 1.8\text{ V}$, and $f_{\text{SAMPLE}} = 1\text{ MSPS}$, unless otherwise noted.

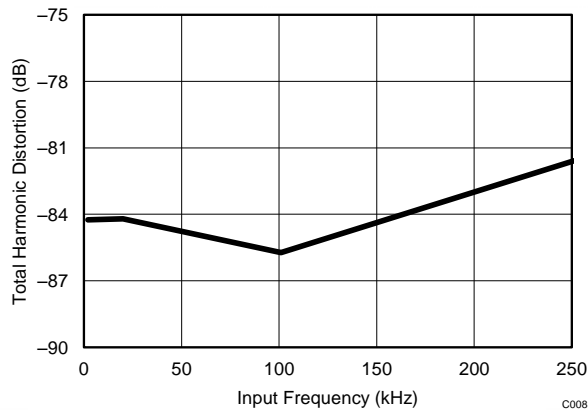

Figure 8. THD vs Input Frequency

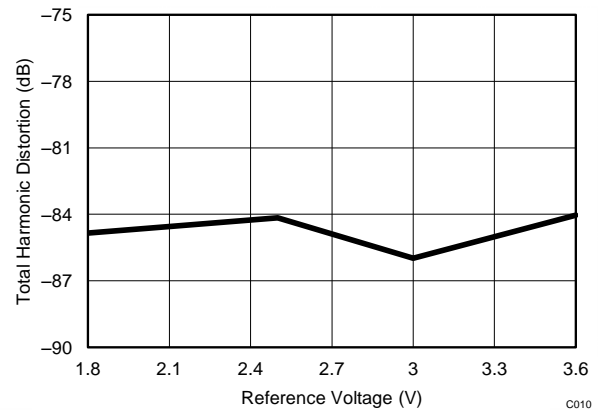

Figure 9. THD vs Reference Voltage (AVDD)

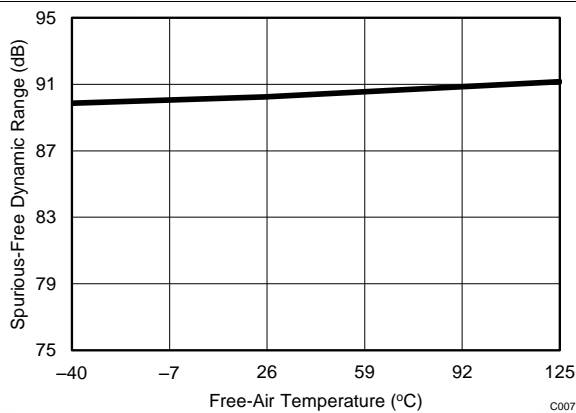

Figure 10. SFDR vs Free-Air Temperature

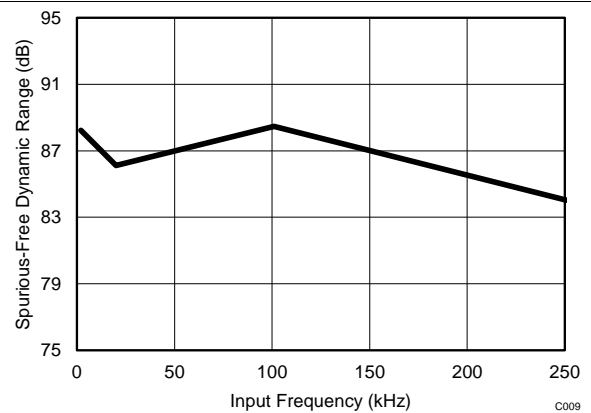

Figure 11. SFDR vs Input Frequency

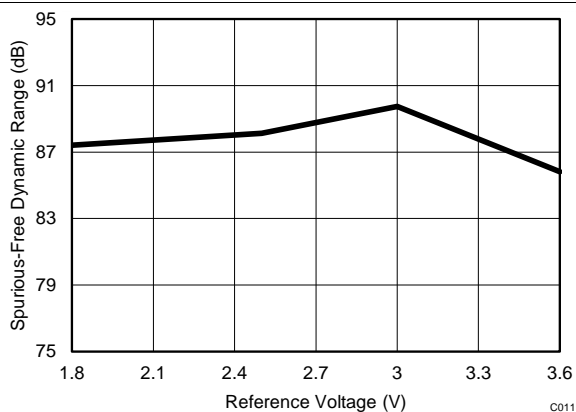

Figure 12. SFDR vs Reference Voltage (AVDD)

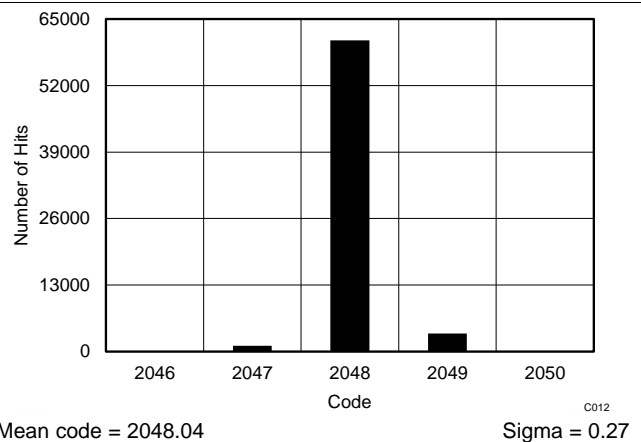

Figure 13. DC Input Histogram

Typical Characteristics (continued)

At $T_A = 25^\circ\text{C}$, $AVDD = 3\text{ V}$, $DVDD = 1.8\text{ V}$, and $f_{\text{SAMPLE}} = 1\text{ MSPS}$, unless otherwise noted.

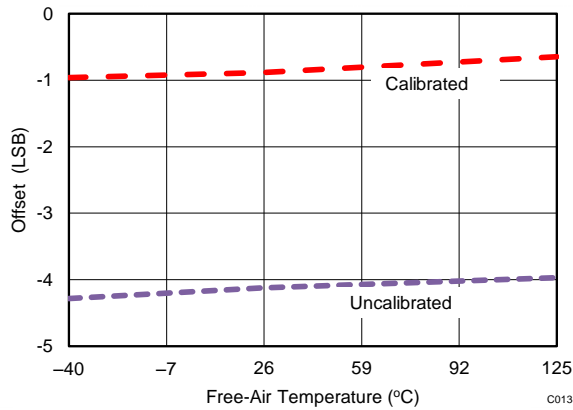

Figure 14. Offset vs Free-Air Temperature

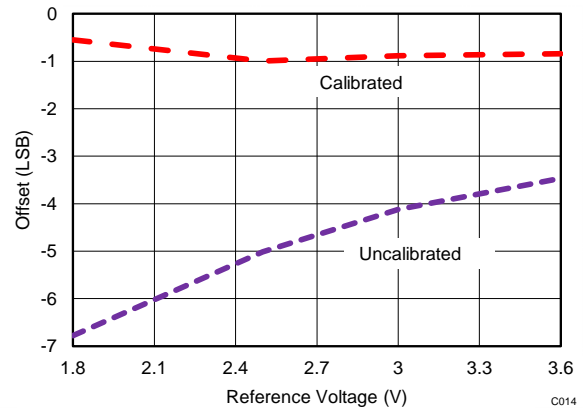

Figure 15. Offset vs Reference Voltage (AVDD)

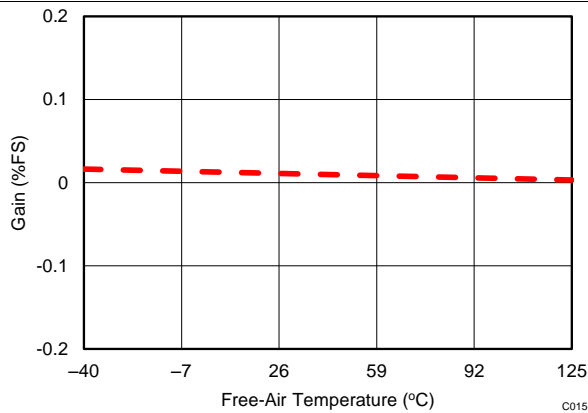

Figure 16. Gain Error vs Free-Air Temperature

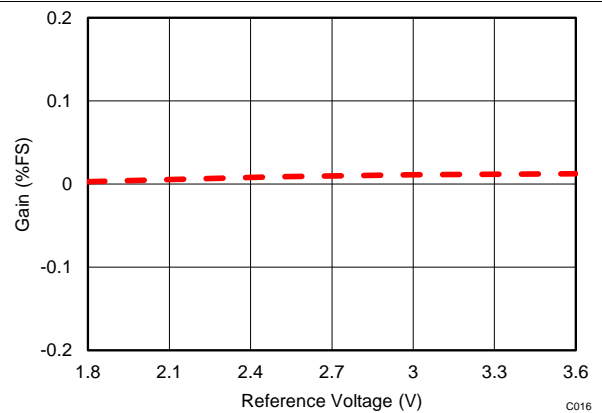

Figure 17. Gain Error vs Reference Voltage (AVDD)

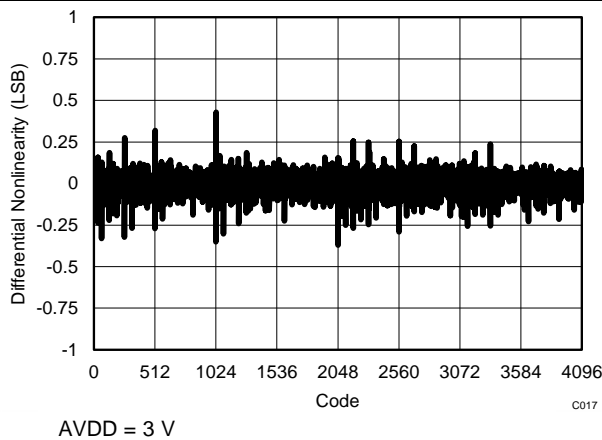

Figure 18. Typical DNL

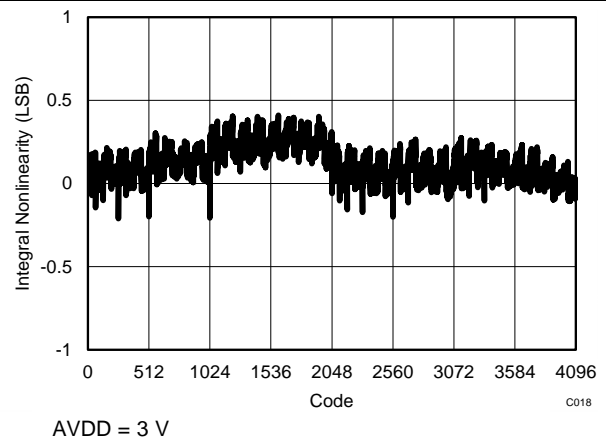

Figure 19. Typical INL

Typical Characteristics (continued)

At $T_A = 25^\circ\text{C}$, $AVDD = 3\text{ V}$, $DVDD = 1.8\text{ V}$, and $f_{\text{SAMPLE}} = 1\text{ MSPS}$, unless otherwise noted.

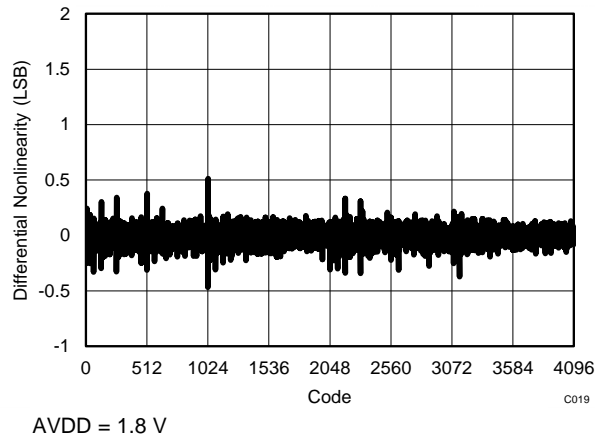

Figure 20. Typical DNL

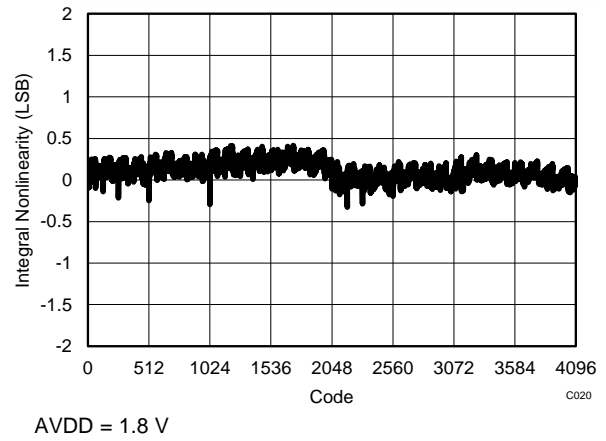

Figure 21. Typical INL

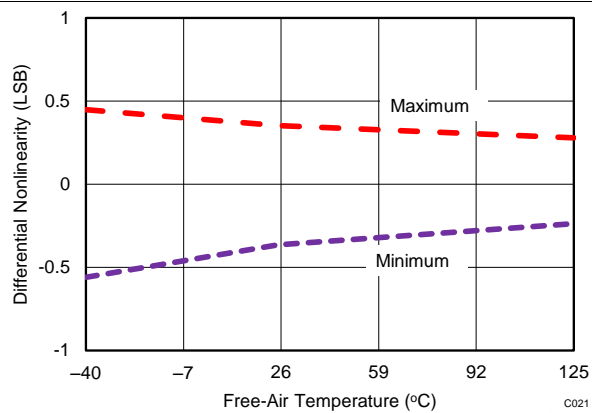

Figure 22. DNL vs Free-Air-Temperature

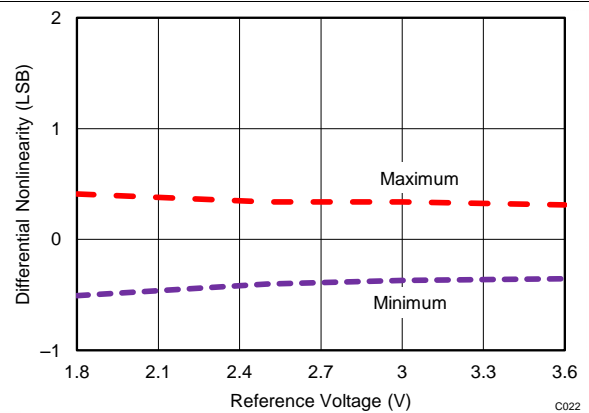

Figure 23. DNL vs Reference Voltage (AVDD)

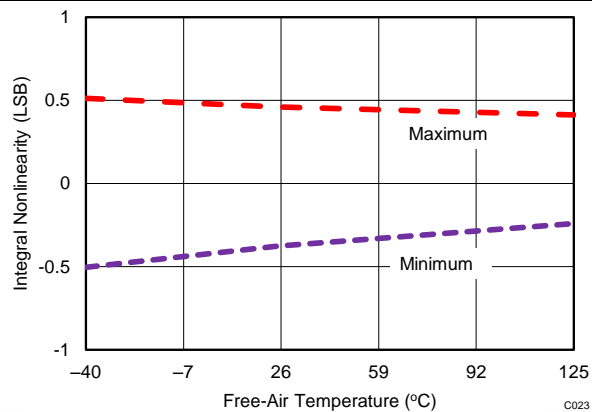

Figure 24. INL vs Free-Air-Temperature

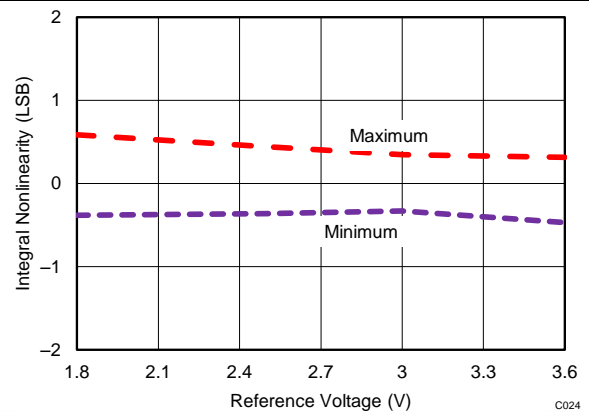
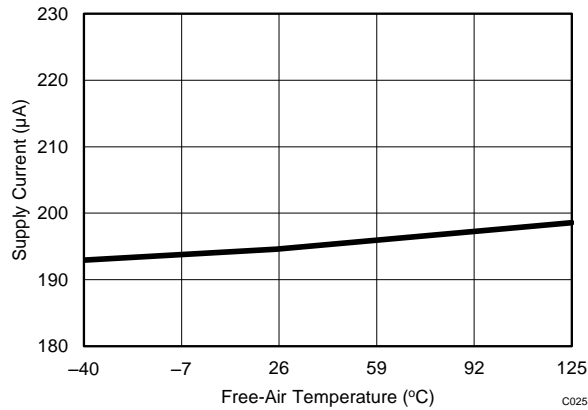

Figure 25. INL vs Reference Voltage (AVDD)

Typical Characteristics (continued)

At $T_A = 25^\circ\text{C}$, $AVDD = 3\text{ V}$, $DVDD = 1.8\text{ V}$, and $f_{\text{SAMPLE}} = 1\text{ MSPS}$, unless otherwise noted.



$f_{\text{Sample}} = 1\text{ MSPS}$

Figure 26. AVDD Supply Current vs Free-Air Temperature

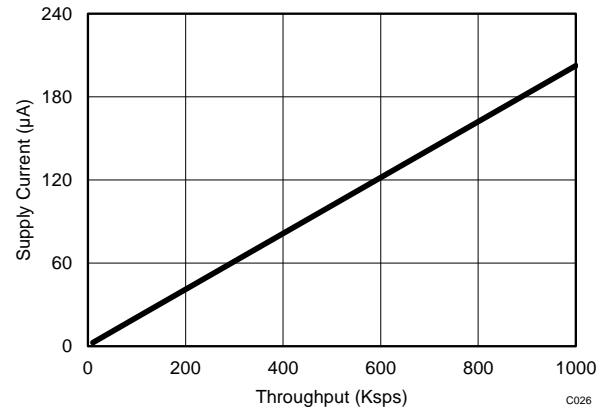

Figure 27. AVDD Supply Current vs Throughput

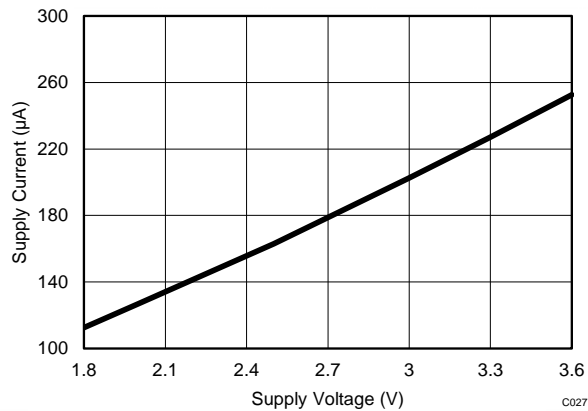

Figure 28. AVDD Supply Current vs AVDD Voltage

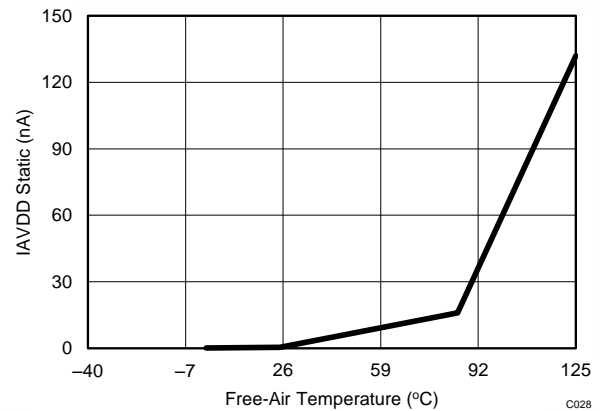

Figure 29. AVDD Static Current vs Free-Air Temperature

7 Parameter Measurement Information

7.1 Digital Voltage Levels

The device complies with the JESD8-7A standard for DVDD from 1.65 V to 1.95 V. Figure 30 shows voltage levels for the digital input and output pins.

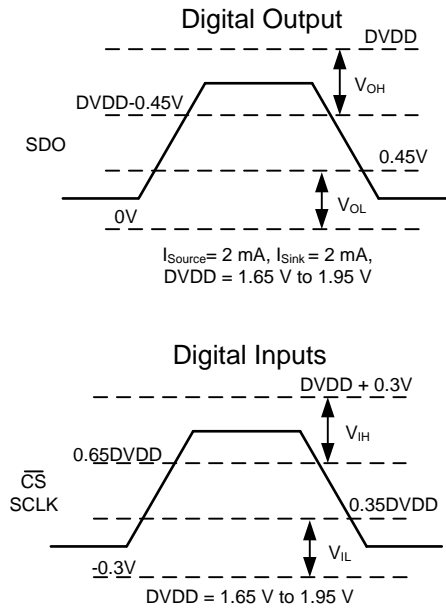

Figure 30. Digital Voltage Levels as per the JESD8-7A Standard

8 Detailed Description

8.1 Overview

The ADS7042 is an ultralow-power, ultra-small analog-to-digital converter (ADC) that supports a wide analog input range. The analog input range for the device is defined by the AVDD supply voltage. The device samples the input voltage across the AINP and AINM pins on the \overline{CS} falling edge and starts the conversion. The clock provided on the SCLK pin is used for conversion and data transfer. During conversions, both the AINP and AINM pins are disconnected from the sampling circuit. After the conversion completes, the sampling capacitors are reconnected across the AINP and AINM pins and the ADS7042 enters acquisition phase.

The device has an internal offset calibration. The offset calibration can be initiated by the user either on power-up or during normal operation; see the [Offset Calibration](#) section for more details.

The device also provides a simple serial interface to the host controller and operates over a wide range of digital power supplies. The ADS7042 requires only a 16-MHz SCLK for supporting a throughput of 1 MSPS. The digital interface also complies with the JESD8-7A (normal range) standard. The [Functional Block Diagram](#) section provides a block diagram of the device.

8.2 Functional Block Diagram

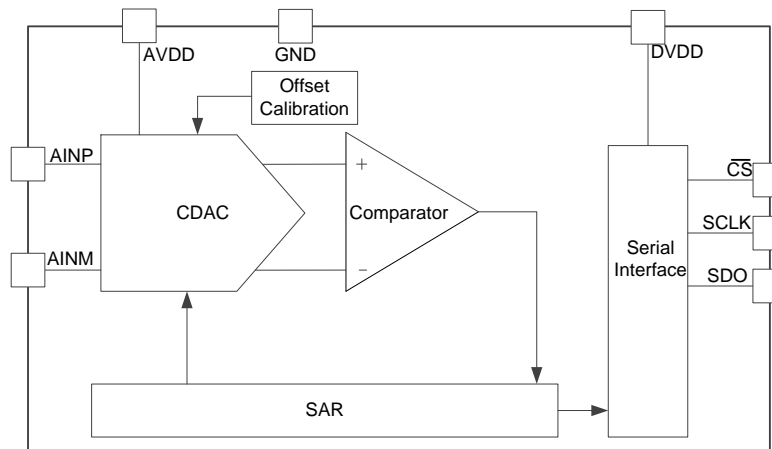

8.3 Feature Description

8.3.1 Reference

The device uses the analog supply voltage (AVDD) as a reference, as shown in [Figure 31](#). TI recommends decoupling the AVDD pin with a 1- μF , low equivalent series resistance (ESR) ceramic capacitor. The minimum capacitor value required for AVDD is 200 nF. The AVDD pin functions as a switched capacitor load to the source powering AVDD. The decoupling capacitor provides the instantaneous charge required by the internal circuit and helps in maintaining a stable dc voltage on the AVDD pin. TI recommends powering the AVDD pin with a low output impedance and low-noise regulator (such as the [TPS79101](#)).

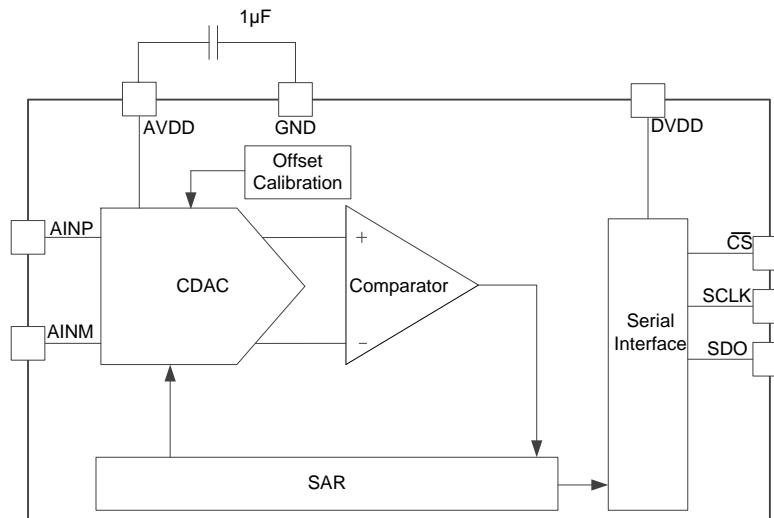

Figure 31. Reference for the Device

Feature Description (continued)

8.3.2 Analog Input

The device supports single-ended analog inputs. The ADC samples the difference between AINP and AINM and converts for this voltage. The device is capable of accepting a signal from -100 mV to 100 mV on the AINM input and is useful in systems where the sensor or signal-conditioning block is far from the ADC. In such a scenario, there can be a difference between the ground potential of the sensor or signal conditioner and the ADC ground. In such cases, use separate wires to connect the ground of the sensor or signal conditioner to the AINM pin. The AINP input is capable of accepting signals from 0 V to AVDD. Figure 32 represents the equivalent analog input circuits for the sampling stage. The device has a low-pass filter followed by the sampling switch and sampling capacitor. The sampling switch is represented by an R_s (typically $50\ \Omega$) resistor in series with an ideal switch and C_s (typically 15 pF) is the sampling capacitor. The ESD diodes are connected from both analog inputs to AVDD and ground.

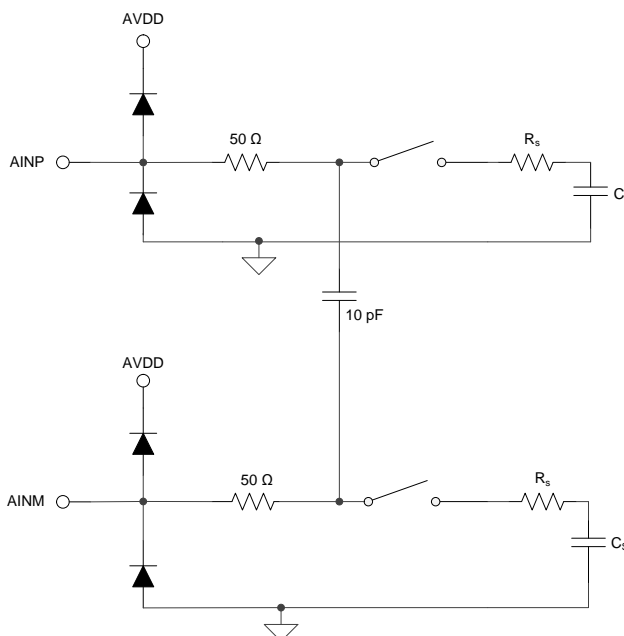

Figure 32. Equivalent Input Circuit for the Sampling Stage

The analog input full-scale range (FSR) is equal to the reference voltage of the ADC. The reference voltage for the device is equal to the analog supply voltage (AVDD). Thus, the device FSR can be determined by Equation 1:

$$\text{FSR} = V_{\text{REF}} = \text{AVDD} \quad (1)$$

8.3.3 ADC Transfer Function

The device output is in straight binary format. The device resolution for a single-ended input can be computed by Equation 2:

$$1\text{ LSB} = V_{\text{REF}} / 2^N$$

where:

- $V_{\text{REF}} = \text{AVDD}$ and
 - $N = 12$
- (2)

Feature Description (continued)

Figure 33 and Table 1 show the ideal transfer characteristics for the device.

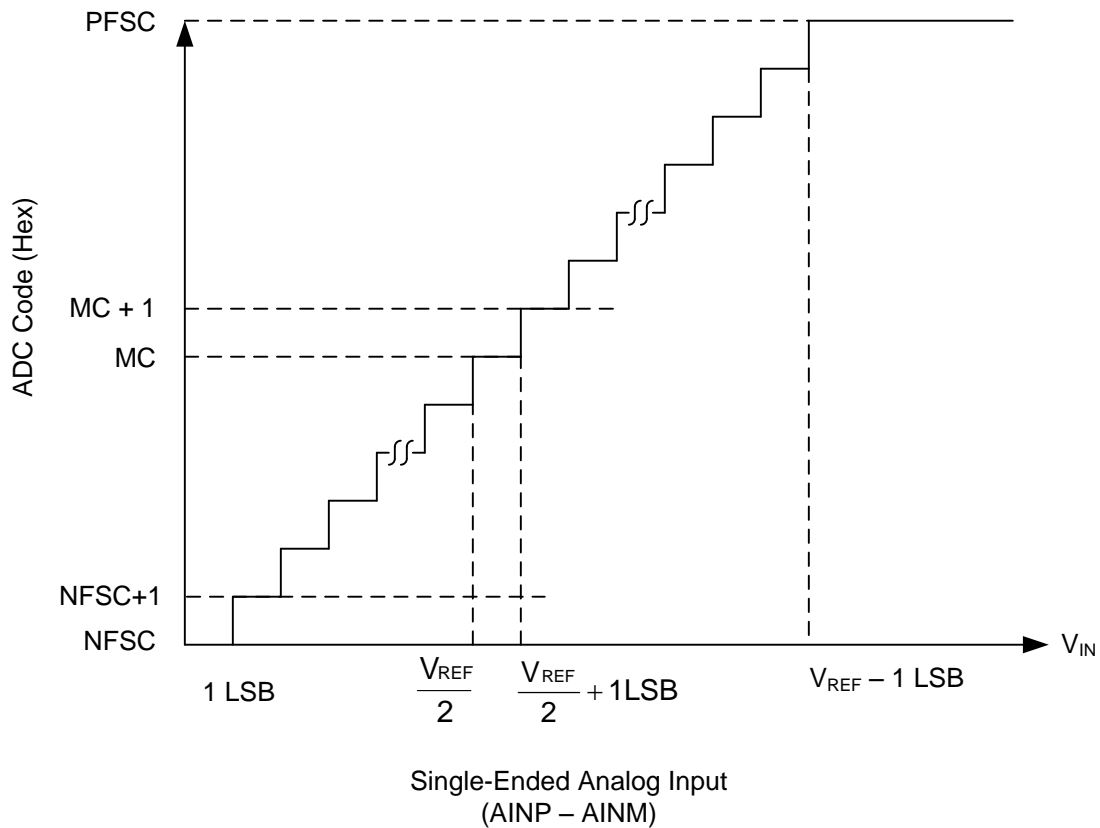

Figure 33. Ideal Transfer Characteristics

Table 1. Transfer Characteristics

INPUT VOLTAGE (AINP – AINM)	CODE	DESCRIPTION	IDEAL OUTPUT CODE
≤ 1 LSB	NFSC	Negative full-scale code	000
1 LSB to 2 LSBs	NFSC + 1	—	001
$(V_{REF} / 2)$ to $(V_{REF} / 2) + 1$ LSB	MC	Mid code	800
$(V_{REF} / 2) + 1$ LSB to $(V_{REF} / 2) + 2$ LSBs	MC + 1	—	801
$\geq V_{REF} - 1$ LSB	PFSC	Positive full-scale code	FFF

8.3.4 Serial Interface

The device supports a simple, SPI-compatible interface to the external host. The \overline{CS} signal defines one conversion and serial transfer frame. A frame starts with a \overline{CS} falling edge and ends with a \overline{CS} rising edge. The SDO pin outputs the ADC conversion results. Figure 34 shows a detailed timing diagram for the serial interface. A minimum delay of t_{SU_CSCK} must elapse between the \overline{CS} falling edge and the first SCLK falling edge. The device uses the clock provided on the SCLK pin for conversion and data transfer. The conversion result is available on the SDO pin with the first two bits set to 0, followed by 12 bits of the conversion result. The first zero is launched on the SDO pin on the \overline{CS} falling edge. Subsequent bits (starting with another 0 followed by the conversion result) are launched on the SDO pin on subsequent SCLK falling edges. The SDO output remains low after 14 SCLKs. A \overline{CS} rising edge ends the frame and brings the serial data bus to 3-state. For acquisition of the next sample, a minimum time of t_{ACQ} must be provided after the conversion of the current sample is completed. For details on timing specifications, see the [Timing Characteristics](#) table.

The device initiates an offset calibration on the first \overline{CS} falling edge after power-up and the SDO output remains low during the first serial transfer frame after power-up. For further details, refer to the [Offset Calibration](#) section.

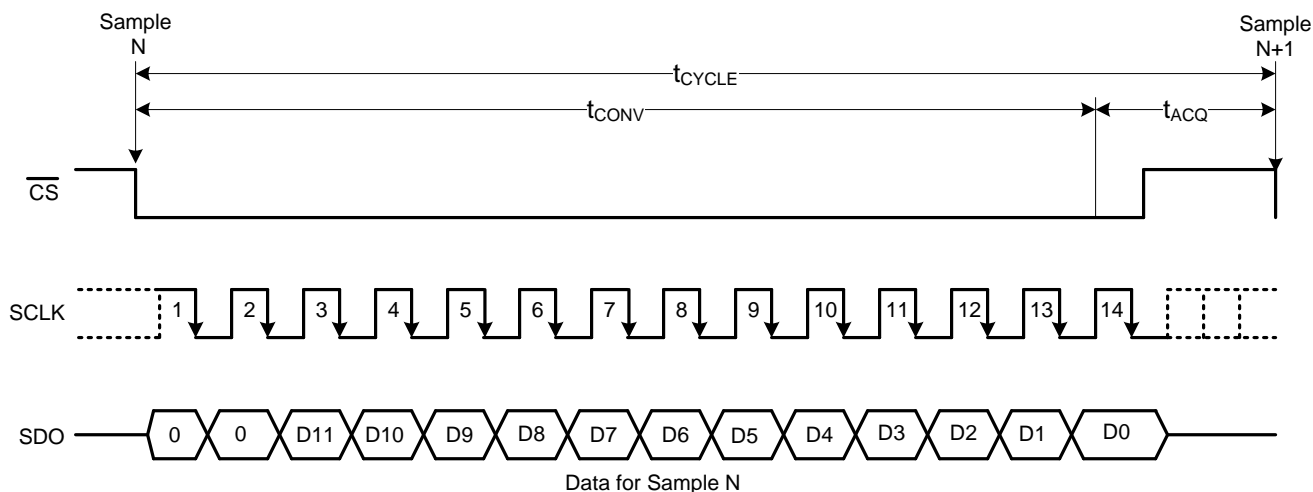
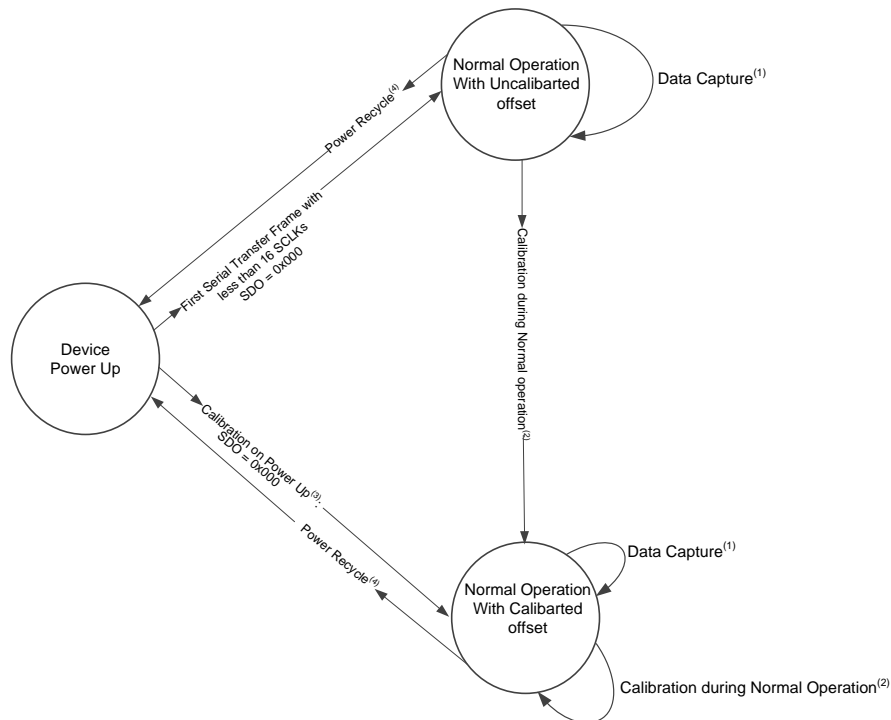

Figure 34. Serial Interface Timing Diagram

8.4 Device Functional Modes

8.4.1 Offset Calibration

The ADS7042 includes a feature to calibrate the device internal offset. During offset calibration, the analog input pins (AINP and AINM) are disconnected from the sampling stage. The device includes an internal offset calibration register (OCR) that stores the offset calibration result. The OCR is an internal register and cannot be accessed by the user through the serial interface. The OCR is reset to zero on power-up. Therefore, TI recommends calibrating the offset on power-up to bring the offset within the specified limits. If the operating temperature or analog supply voltage reflect a significant change, the offset can be recalibrated during normal operation. Figure 35 shows the offset calibration process.



- (1) See the [Timing Characteristics](#) section for timing specifications.
- (2) See the [Offset Calibration During Normal Operation](#) section for details.
- (3) See the [Offset Calibration on Power-Up](#) section for details.
- (4) The power recycle on the AVDD supply is required to reset the offset calibration and to bring the device to a power-up state.

Figure 35. Offset Calibration

Device Functional Modes (continued)

8.4.1.1 Offset Calibration on Power-Up

The device initiates offset calibration on the first \overline{CS} falling edge after power-up and calibration completes if the \overline{CS} pin remains low for at least 16 SCLK falling edges after the first \overline{CS} falling edge. The SDO output remains low during calibration. The minimum acquisition time must be provided after calibration for acquiring the first sample. If the device is not provided with at least 16 SCLKs during the first serial transfer frame after power-up, the OCR is not updated. Table 2 provides the timing parameters for offset calibration on power-up.

For subsequent samples, the device adjusts the conversion results with the value stored in the OCR. The conversion result adjusted with the value stored in OCR is provided by the device on the SDO output. Figure 36 shows the timing diagram for offset calibration on power-up.

Table 2. Offset Calibration on Power-Up

		MIN	TYP	MAX	UNIT
$f_{CLK-CAL}$	SCLK frequency for calibration for 2.25 V < AVDD < 3.6 V			16	MHz
$f_{CLK-CAL}$	SCLK frequency for calibration for 1.65 V < AVDD < 2.25 V			12	MHz
$t_{POWERUP-CAL}$	Calibration time at power-up	15 t_{SCLK}			ns
t_{ACQ}	Acquisition time	200			ns
t_{PH_CS}	\overline{CS} high time	t_{ACQ}			ns
t_{SU_CSCK}	Setup time: \overline{CS} falling to SCLK falling	15			ns
t_{D_CKCS}	Delay time: last SCLK falling to \overline{CS} rising	10			ns

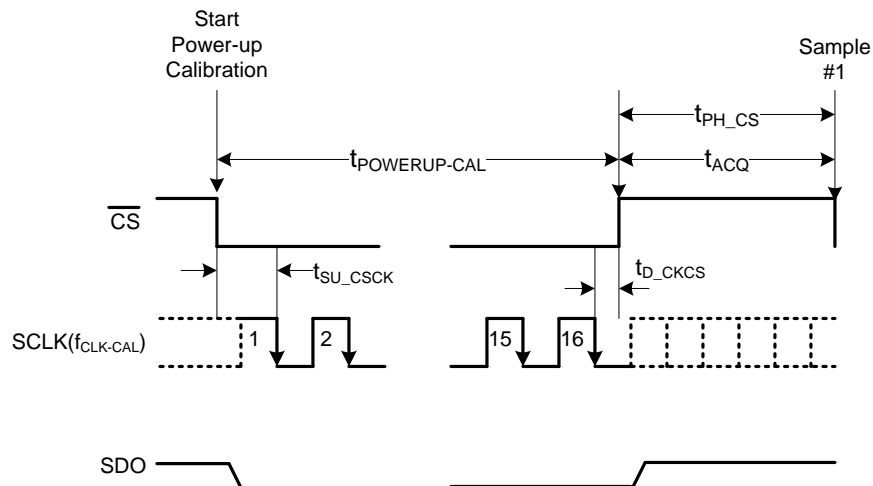

Figure 36. Offset Calibration on Power-Up Timing Diagram

8.4.1.2 Offset Calibration During Normal Operation

Offset calibration can be done during normal device operation if at least 32 SCLK falling edges are provided in one serial transfer frame. During the first 14 SCLKs, the device converts the sample acquired on the CS falling edge and provides data on the SDO output. The device initiates the offset calibration on the 17th SCLK falling edge and calibration completes on the 32nd SCLK falling edge. The SDO output remains low after the 14th SCLK falling edge and SDO goes to 3-state after \overline{CS} goes high. If the device is provided with less than 32 SCLKs during a serial transfer frame, the OCR is not updated. Table 3 provides the timing parameters for offset calibration during normal operation.

For subsequent samples, the device adjusts the conversion results with the value stored in the OCR. The conversion result adjusted with the value stored in the OCR is provided by the device on the SDO output. Figure 37 shows the timing diagram for offset calibration during normal operation.

Table 3. Offset Calibration During Normal Operation

		MIN	TYP	MAX	UNIT
$f_{\text{CLK-CAL}}$	SCLK frequency for calibration for $2.25\text{ V} < AVDD < 3.6\text{ V}$			16	MHz
$f_{\text{CLK-CAL}}$	SCLK frequency for calibration for $1.65\text{ V} < AVDD < 2.25\text{ V}$			12	MHz
t_{CAL}	Calibration time during normal operation	15 t_{SCLK}			ns
t_{ACQ}	Acquisition time	200			ns
$t_{\text{PH-CS}}$	\overline{CS} high time	t_{ACQ}			ns
$t_{\text{SU-CSCK}}$	Setup time: \overline{CS} falling to SCLK falling	15			ns
$t_{\text{D-CKCS}}$	Delay time: last SCLK falling to \overline{CS} rising	10			ns

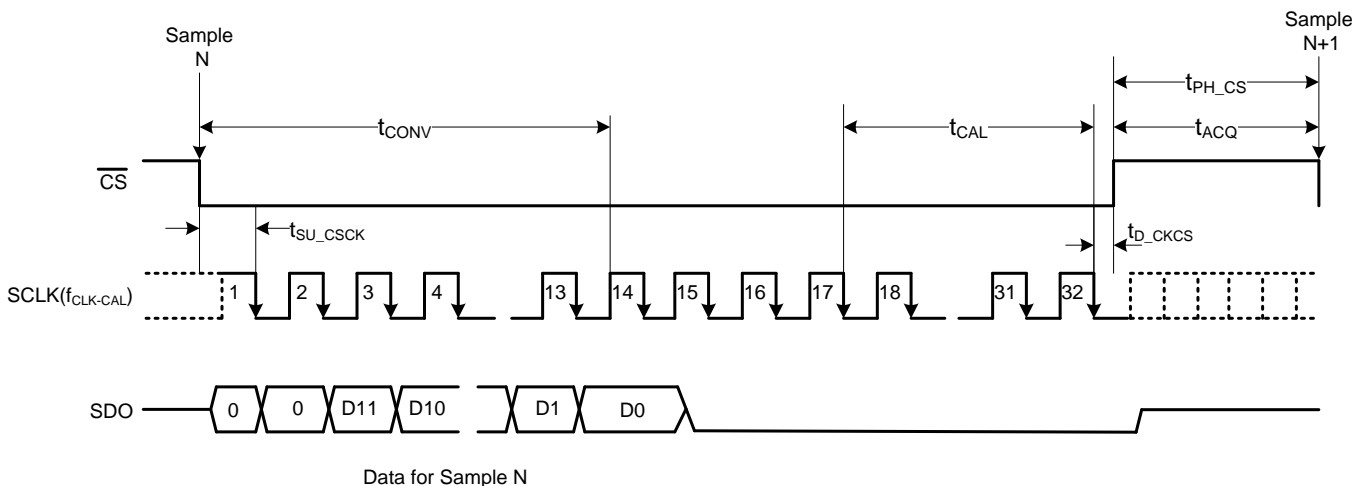

Figure 37. Offset Calibration During Normal Operation Timing Diagram

9 Application and Implementation

NOTE

Information in the following applications sections is not part of the TI component specification, and TI does not warrant its accuracy or completeness. TI's customers are responsible for determining suitability of components for their purposes. Customers should validate and test their design implementation to confirm system functionality.

9.1 Application Information

The two primary circuits required to maximize the performance of a high-precision, successive approximation register (SAR), analog-to-digital converter (ADC) are the input driver and the reference driver circuits. This section details some general principles for designing the input driver circuit, reference driver circuit, and provides some application circuits designed for the ADS7042.

9.2 Typical Applications

9.2.1 Single-Supply DAQ with the ADS7042

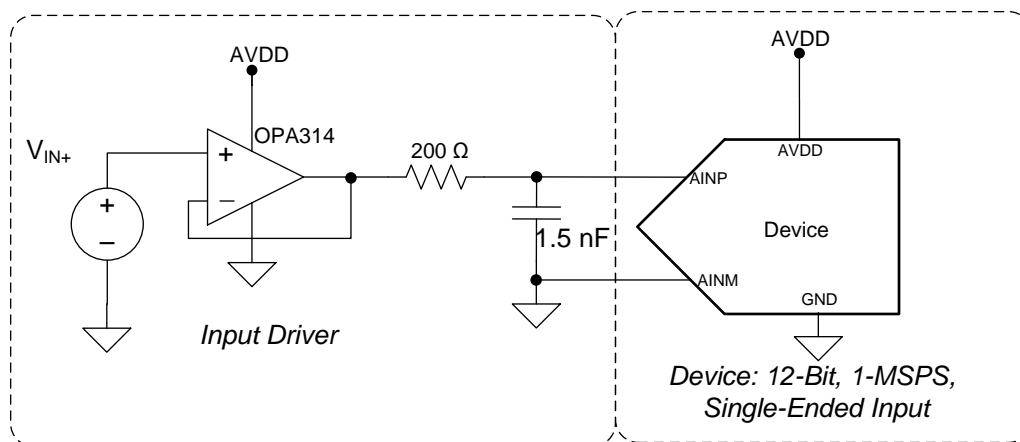

Figure 38. DAQ Circuit: Single-Supply DAQ

9.2.1.1 Design Requirements

The goal of this application is to design a single-supply digital acquisition (DAQ) circuit based on the ADS7042 with SNR greater than 68 dB and THD less than -80 dB for input frequencies of 2.5 kHz at a throughput of 1 MSPS.

9.2.1.2 Detailed Design Procedure

The input driver circuit for a high-precision ADC mainly consists of two parts: a driving amplifier and an antialiasing filter. Careful design of the front-end circuit is critical to meet the linearity and noise performance of a high-precision ADC.

Typical Applications (continued)

9.2.1.2.1 Antialiasing Filter

Converting analog-to-digital signals requires sampling an input signal at a rate greater than or equal to the Nyquist rate. Any higher frequency content in the input signal beyond half the sampling frequency is digitized and folded back into the low-frequency spectrum. This process is called *aliasing*. Therefore, an external, antialiasing filter must be used to remove the harmonic content from the input signal before being sampled by the ADC. An antialiasing filter is designed as a low-pass RC filter, for which the 3-dB bandwidth is optimized for noise, response time, and throughput. For dc signals with fast transients (including multiplexed input signals), a high-bandwidth filter is designed to allow accurately settling the signal at the ADC inputs during the small acquisition time window. Figure 39 provides the equation for determining the bandwidth of the antialiasing filter.

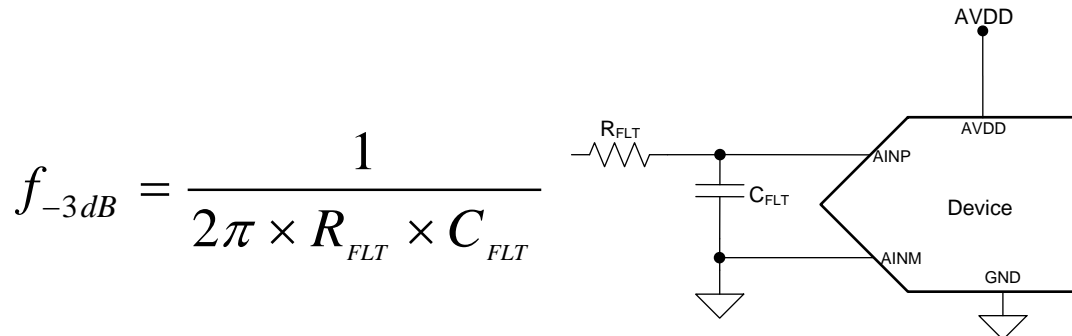

Figure 39. Antialiasing Filter

For ac signals, the filter bandwidth must be kept low to band limit the noise fed into the ADC input, thereby increasing the signal-to-noise ratio (SNR) of the system. Besides filtering the noise from the front-end drive circuitry, the RC filter also helps attenuate the sampling charge injection from the switched-capacitor input stage of the ADC. A filter capacitor, C_{FLT} , is connected across the ADC inputs. This capacitor helps reduce the sampling charge injection and provides a charge bucket to quickly charge the internal sample-and-hold capacitors during the acquisition process. As a rule of thumb, the value of this capacitor is at least 20 times the specified value of the ADC sampling capacitance. For this device, the input sampling capacitance is equal to 15 pF. Thus, the value of C_{FLT} is greater than 300 pF. Select a COG- or NPO-type capacitor because these capacitor types have a high-Q, low-temperature coefficient, and stable electrical characteristics under varying voltages, frequency, and time.

Note that driving capacitive loads can degrade the phase margin of the input amplifiers, thus making the amplifier marginally unstable. To avoid amplifier stability issues, series isolation resistors (R_{FLT}) are used at the output of the amplifiers. A higher value of R_{FLT} is helpful from the amplifier stability perspective, but adds distortion as a result of interactions with the nonlinear input impedance of the ADC. Distortion increases with source impedance, input signal frequency, and input signal amplitude. Therefore, the selection of R_{FLT} requires balancing the stability and distortion of the design.

The input amplifier bandwidth is typically much higher than the cutoff frequency of the antialiasing filter. Thus, TI strongly recommends performing a SPICE simulation to confirm that the amplifier has more than 40° phase margin with the selected filter. Simulation is critical because even with high-bandwidth amplifiers, some amplifiers can require more bandwidth than others to drive similar filters.

Typical Applications (continued)

9.2.1.2.2 Input Amplifier Selection

Selection criteria for the input amplifiers is highly dependent on the input signal type and the performance goals of the data acquisition system. Some key amplifier specifications to consider when selecting an appropriate amplifier to drive the inputs of the ADC are:

- **Small-signal bandwidth:** Select the small-signal bandwidth of the input amplifiers to be high enough to settle the input signal in the acquisition time of the ADC. Higher bandwidth reduces the closed-loop output impedance of the amplifier, thus allowing the amplifier to more easily drive the low cutoff frequency RC filter at the ADC inputs. Higher bandwidth also minimizes the harmonic distortion at higher input frequencies. In order to maintain the overall stability of the input driver circuit, the select the amplifier bandwidth as described in [Equation 3](#).

$$GBW \geq 4 \times \frac{1}{2\pi \times R_{FLT} \times C_{FLT}}$$

where:

- GBW = unity gain bandwidth (3)
- **Noise:** Noise contribution of the front-end amplifiers must be low enough to prevent any degradation in SNR performance of the system. As a rule of thumb, to ensure that the noise performance of the data acquisition system is not limited by the front-end circuit, keep the total noise contribution from the front-end circuit below 20% of the input-referred noise of the ADC. Noise from the input driver circuit is band limited by designing a low cutoff frequency RC filter, as explained in [Equation 4](#).

$$N_G \times \sqrt{\left(\frac{V_{1/f_AMP_PP}}{6.6}\right)^2 + e_{n_RMS}^2 \times \frac{\pi}{2} \times f_{-3dB}} \leq \frac{1}{5} \times \frac{V_{REF}}{2\sqrt{2}} \times 10^{-\left(\frac{SNR(dB)}{20}\right)}$$

where:

- V_{1/f_AMP_PP} is the peak-to-peak flicker noise in $\mu VRMS$,
- e_{n_RMS} is the amplifier broadband noise,
- f_{-3dB} is the -3 -dB bandwidth of the RC filter, and
- N_G is the noise gain of the front-end circuit, which is equal to 1 in the buffer configuration. (4)
- **Settling time:** For dc signals with fast transients that are common in a multiplexed application, the input signal must settle to the desired accuracy at the inputs of the ADC during the acquisition time window. This condition is critical to maintain the overall linearity performance of the ADC. Typically, the amplifier data sheets specify the output settling performance only up to 0.1% to 0.001%, which may not be sufficient for the desired accuracy. Therefore, always verify the settling behavior of the input driver with TINA™-SPICE simulations before selecting the amplifier.

The OPA314 is selected for this application for its rail-to-rail input and output swing, low-noise ($14 \text{ nV}/\sqrt{\text{Hz}}$), and low-power ($150 \mu\text{A}$) performance to support a single-supply data acquisition circuit.

9.2.1.2.3 Reference Circuit

The analog supply voltage of the device is also used as a voltage reference for conversion. TI recommends decoupling the AVDD pin with a $1\text{-}\mu\text{F}$, low-ESR ceramic capacitor. The minimum capacitor value required for AVDD is 200 nF .

Typical Applications (continued)

9.2.1.3 Application Curve

Figure 40 shows the FFT plot for the ADS7042 with a 2.5-kHz input frequency used for the circuit in Figure 38.

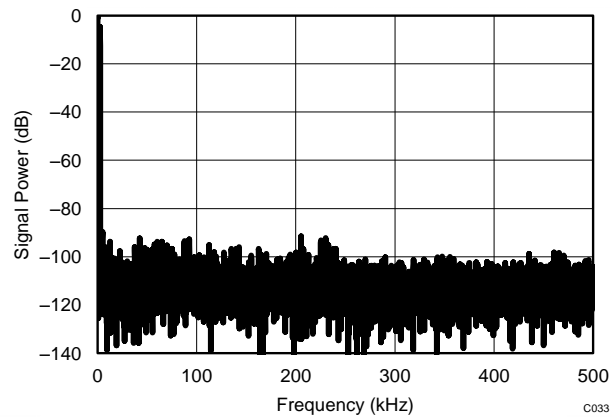

SNR = 69 dB THD = -80 dB SINAD = 68.6 dB
 Number of samples = 32768

Figure 40. Test Results for the ADS7042 and OPA314 for a 2.5-kHz Input

Typical Applications (continued)

9.2.2 DAQ Circuit with the ADS7042 for Maximum SINAD

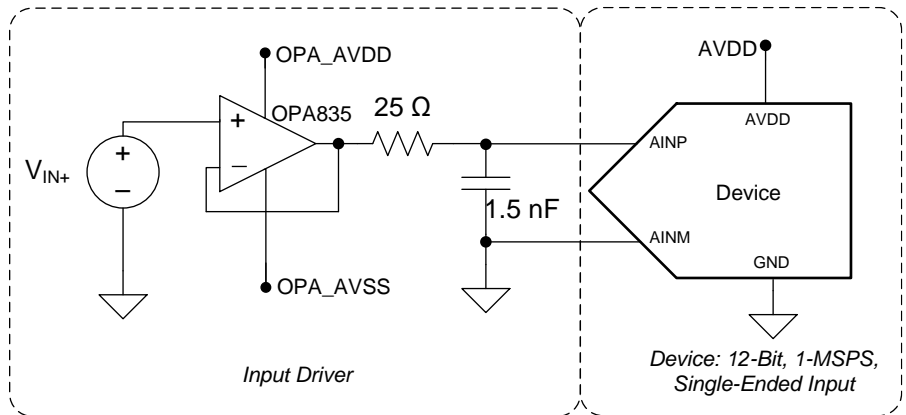

Figure 41. ADS7042 DAQ Circuit: Maximum SINAD for Input Frequencies up to 250 kHz

9.2.2.1 Design Requirements

The goal of this application is to design a data acquisition circuit based on the ADS7042 with SINAD greater than 69.5 dB for input frequencies up to 250 kHz.

9.2.2.2 Detailed Design Procedure

To achieve a SINAD of 69.5 dB, the operational amplifier must have high bandwidth in order to settle the input signal within the acquisition time of the ADC. The operational amplifier must have low noise to keep the total system noise below 20% of the input-referred noise of the ADC. For the application circuit shown in [Figure 41](#), the [OPA835](#) is selected for its high bandwidth (56 MHz) and low noise (9.3 nV/ $\sqrt{\text{Hz}}$).

	<p>For a step-by-step design procedure, circuit schematics, bill of materials, PCB files, simulation results, and test results, refer to TI Precision Design TIPD168, Three 12-Bit Data Acquisition Reference Designs Optimized for Low Power and Ultra-Small Form Factor (TIDU390).</p>
--	--

9.2.2.3 Application Curves

Figure 42 shows the FFT plot for the ADS7042 with a 2-kHz input frequency used for the circuit in Figure 41. Figure 43 shows the FFT plot for the ADS7042 with a 250-kHz input frequency used for the circuit in Figure 41.

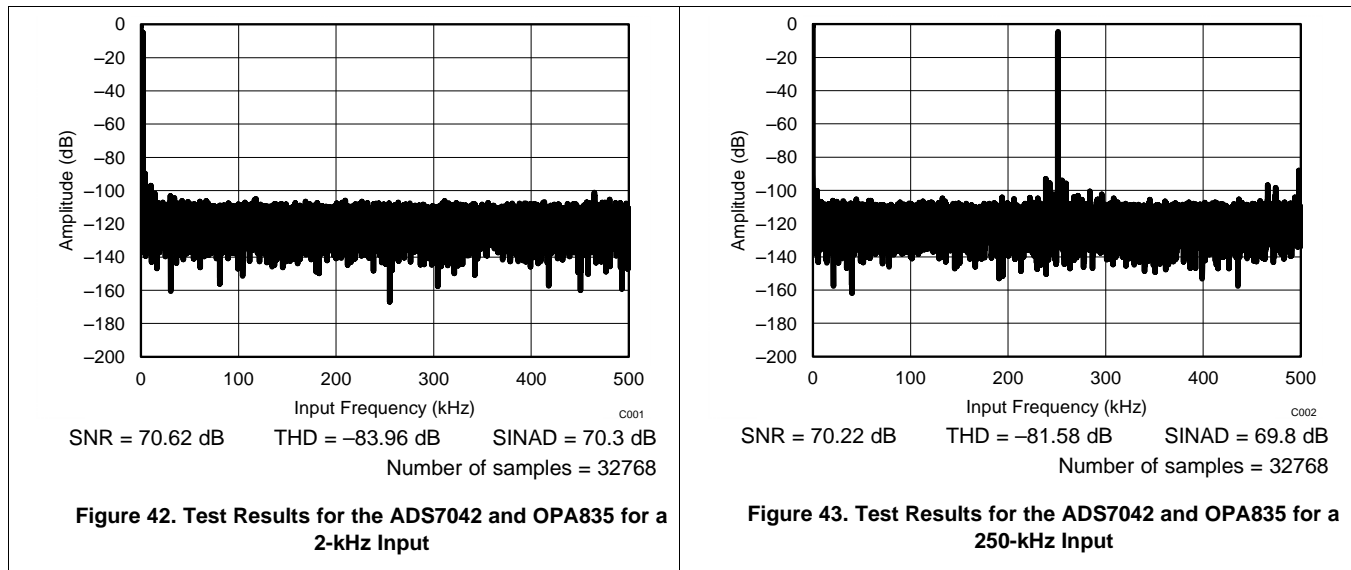

9.2.3 12-Bit, 10-kSPS DAQ Circuit Optimized for DC Sensor Measurements

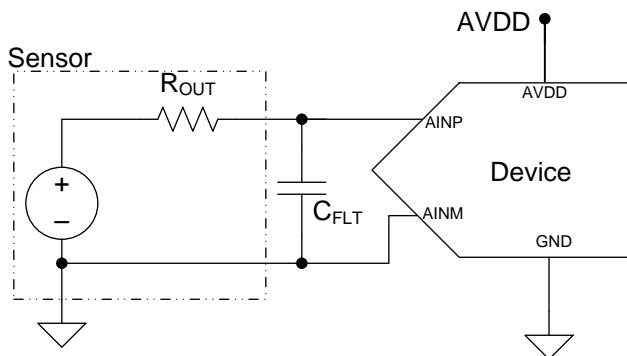

Figure 44. Interfacing the Device Directly with Sensors

In applications where the input is very slow moving and the overall system ENOB is not a critical parameter, a DAQ circuit can be designed without the input driver for the ADC. This type of a use case is of particular interest for applications in which the primary goal is to achieve the absolute lowest power possible. Typical applications that fall into this category are low-power sensor applications (such as temperature, pressure, humidity, gas, and chemical).

9.2.3.1 Design Requirements

For this design example, use the parameters listed in Table 4 as the input parameters.

Table 4. Design Parameters

DESIGN PARAMETER	GOAL VALUE
Throughput	10 kSPS
SNR at 100 Hz	70 dB
THD at 100 Hz	75dB
SINAD at 100 Hz	69 dB
ENOB	11
Power	10 μ W

9.2.3.2 Detailed Design Procedure

The ADS7042 can be directly interfaced with sensors at lower throughputs without the need of an amplifier buffer. The analog input source drive must be capable of driving the switched capacitor load of a SAR ADC and settling the analog input signal within the acquisition time of the SAR ADC. However, the output impedance of the sensor must be taken into account when interfacing a SAR ADC directly with sensors. Drive the analog input of the SAR ADC with a low impedance source. The input signal requires more acquisition time to settle to the desired accuracy because of the higher output impedance of the sensor. The simplified circuit for a sensor as a voltage source with output impedance (R_{OUT}) is shown in Figure 44.

The acquisition time of a SAR ADC (such as the ADS7042) can be increased by reducing throughput in the following ways:

1. Reducing the SCLK frequency to reduce the throughput, or
2. Keeping the SCLK fixed at the highest permissible value (that is, 16 MHz for the device) and increasing the CS high time.

Table 5 lists the acquisition time for the above two cases for a throughput of 100 kSPS. Clearly, case 2 provides more acquisition time for the input signal to settle.

Table 5. Acquisition Time with Different SCLK Frequencies

CASE	SCLK	t _{cycle}	CONVERSION TIME (= 12.5 × t _{SCLK} + t _{SU_CSCK})	ACQUISITION TIME (= t _{cycle} - t _{conv})
1	1.6 MHz	10 μs	7.8125 μs	2.1875 μs
2	16 MHz	10 μs	0.78125 μs	9.21875 μs



For a step-by-step design procedure, circuit schematics, bill of materials, PCB files, simulation results, and test results, refer to [TI Precision Design TIPD168, Three 12-Bit Data Acquisition Reference Designs Optimized for Low Power and Ultra-Small Form Factor \(TIDU390\)](#).

9.2.3.3 Application Curve

When the output impedance of the sensor increases, the time required for the input signal to settle increases and the performance of the SAR ADC starts degrading if the input signal does not settle within the acquisition time of the ADC. The performance of the SAR ADC can be improved by reducing the throughput to provide enough time for the input signal to settle. Figure 45 provides the results for ENOB achieved from the ADS7042 for case 2 at different throughputs with different input impedances at the device input.

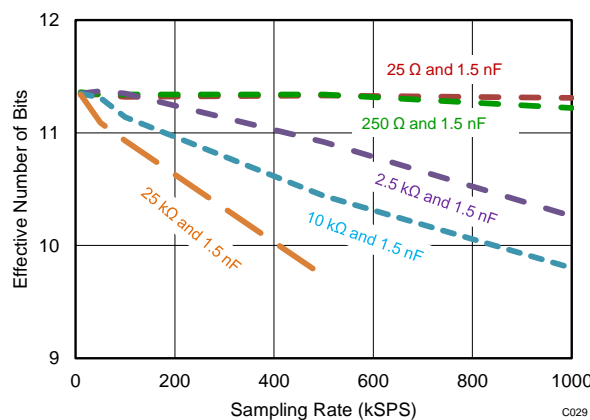

Figure 45. ENOB (Effective Number of Bits) Achieved from the ADS7042 at Different Throughputs

Table 6 shows the results and performance summary for this 12-bit, 10-kSPS DAQ circuit application.

Table 6. Results and Performance Summary for 12-Bit, 10-kSPS DAQ Circuit for DC Sensor Measurements

DESIGN PARAMETER	GOAL VALUE	ACHIEVED RESULT
Throughput	10 kSPS	10 kSPS
SNR at 100 Hz	70 dB	70.6 dB
THD at 100 Hz	75dB	83.5 dB
SINAD at 100 Hz	69dB	70.4 dB
ENOB	11	11.4
Power	10 μW	7 μW

10 Power-Supply Recommendations

10.1 AVDD and DVDD Supply Recommendations

The ADS7042 has two separate power supplies: AVDD and DVDD. The device operates on AVDD; DVDD is used for the interface circuits. AVDD and DVDD can be independently set to any value within the permissible ranges. The AVDD supply also defines the full-scale input range of the device. Always set the AVDD supply to be greater than or equal to the maximum input signal to avoid saturation of codes. Decouple the AVDD and DVDD pins individually with 1- μ F ceramic decoupling capacitors, as shown in Figure 46. The minimum capacitor value required for AVDD and DVDD is 200 nF and 20 nF, respectively. If both supplies are powered from the same source, a minimum capacitor value of 220 nF is required for decoupling.

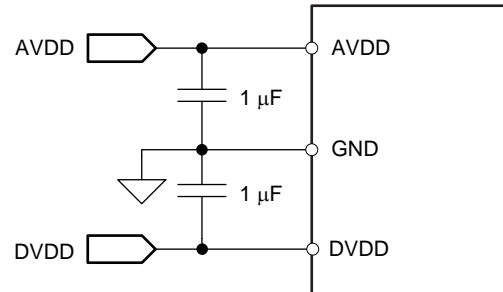

Figure 46. Power-Supply Decoupling

10.2 Estimating Digital Power Consumption

The current consumption from the DVDD supply depends on the DVDD voltage, load capacitance on the SDO line, and the output code. The load capacitance on the SDO line is charged by the current from the SDO pin on every rising edge of the data output and is discharged on every falling edge of the data output. The current consumed by the device from the DVDD supply can be calculated by Equation 5:

$$I_{DVDD} = C \times V \times f$$

where:

- C = Load capacitance on the SDO line,
- V = DVDD supply voltage, and
- f = Number of transitions on the SDO output. (5)

The number of transitions on the SDO output depends on the output code, and thus changes with the analog input. The maximum value of f occurs when data output on the SDO change on every SCLK. SDO changing on every SCLK results in an output code of AAAh or 555h. For an output code of AAAh or 555h at a 1-MSPS throughput, the frequency of transitions on the SDO output is 6MHz.

For the current consumption to remain at the lowest possible value, keep the DVDD supply at the lowest permissible value and keep the capacitance on the SDO line as low as possible.

10.3 Optimizing Power Consumed by the Device

- Keep the analog supply voltage (AVDD) as close as possible to the analog input voltage. Set AVDD to be greater than or equal to the analog input voltage of the device.
- Keep the digital supply voltage (DVDD) at the lowest permissible value.
- Reduce the load capacitance on the SDO output.
- Run the device at the optimum throughput. Power consumption reduces with throughput.

11 Layout

11.1 Layout Guidelines

Figure 47 shows a board layout example for the ADS7042. Use a ground plane underneath the device and partition the PCB into analog and digital sections. Avoid crossing digital lines with the analog signal path and keep the analog input signals and the reference input signals away from noise sources. In Figure 47, the analog input and reference signals are routed on the top and left side of the device and the digital connections are routed on the bottom and right side of the device.

The power sources to the device must be clean and well-bypassed. Use 1- μ F ceramic bypass capacitors in close proximity to the analog (AVDD) and digital (DVDD) power-supply pins. Avoid placing vias between the AVDD and DVDD pins and the bypass capacitors. Connect all ground pins to the ground plane using short, low-impedance paths. The AVDD supply voltage for the ADS7042 also functions as a reference for the device. Place the decoupling capacitor (C_{REF}) for AVDD close to the device AVDD and GND pins and connect C_{REF} to the device pins with thick copper tracks, as shown in Figure 47.

The fly-wheel RC filters are placed close to the device. Among ceramic surface-mount capacitors, COG (NPO) ceramic capacitors provide the best capacitance precision. The type of dielectric used in COG (NPO) ceramic capacitors provides the most stable electrical properties over voltage, frequency, and temperature changes.

11.2 Layout Example

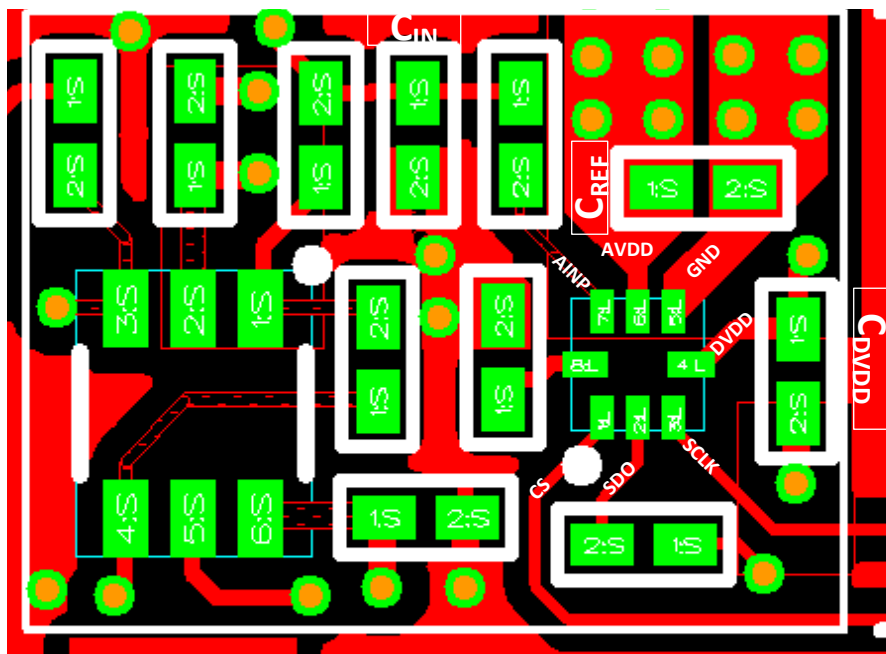

Figure 47. Example Layout

12 器件和文档支持

12.1 文档支持

12.1.1 相关文档

相关文档如下：

- 《OPA314 数据表》（文献编号 [SBOS563](#)）
- 《OPA835 数据表》（文献编号 [SLOS713](#)）
- 《TPS79101 数据表》（文献编号 [SLVS325](#)）
- 《TIPD168 参考指南》（文献编号 [TIDU390](#)）

12.2 社区资源

The following links connect to TI community resources. Linked contents are provided "AS IS" by the respective contributors. They do not constitute TI specifications and do not necessarily reflect TI's views; see TI's [Terms of Use](#).

TI E2E™ Online Community *TI's Engineer-to-Engineer (E2E) Community*. Created to foster collaboration among engineers. At e2e.ti.com, you can ask questions, share knowledge, explore ideas and help solve problems with fellow engineers.

Design Support *TI's Design Support* Quickly find helpful E2E forums along with design support tools and contact information for technical support.

12.3 商标

E2E is a trademark of Texas Instruments.
 TINA is a trademark of Texas Instruments, Inc.
 串行外设接口 (SPI) is a trademark of Motorola.
 All other trademarks are the property of their respective owners.

12.4 静电放电警告



ESD 可能会损坏该集成电路。德州仪器 (TI) 建议通过适当的预防措施处理所有集成电路。如果不遵守正确的处理措施和安装程序，可能会损坏集成电路。

ESD 的损坏小至导致微小的性能降级，大至整个器件故障。精密的集成电路可能更容易受到损坏，这是因为非常细微的参数更改都可能会导致器件与其发布的规格不相符。

12.5 Glossary

[SLYZ022](#) — *TI Glossary*.

This glossary lists and explains terms, acronyms, and definitions.

13 机械、封装和可订购信息

以下页中包括机械、封装和可订购信息。这些信息是针对指定器件可提供的最新数据。这些数据会在无通知且不对本文档进行修订的情况下发生改变。欲获得该数据表的浏览器版本，请查阅左侧的导航栏。

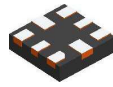

RUG0008A

PACKAGE OUTLINE
X2QFN - 0.4 mm max height

PLASTIC QUAD FLATPACK - NO LEAD

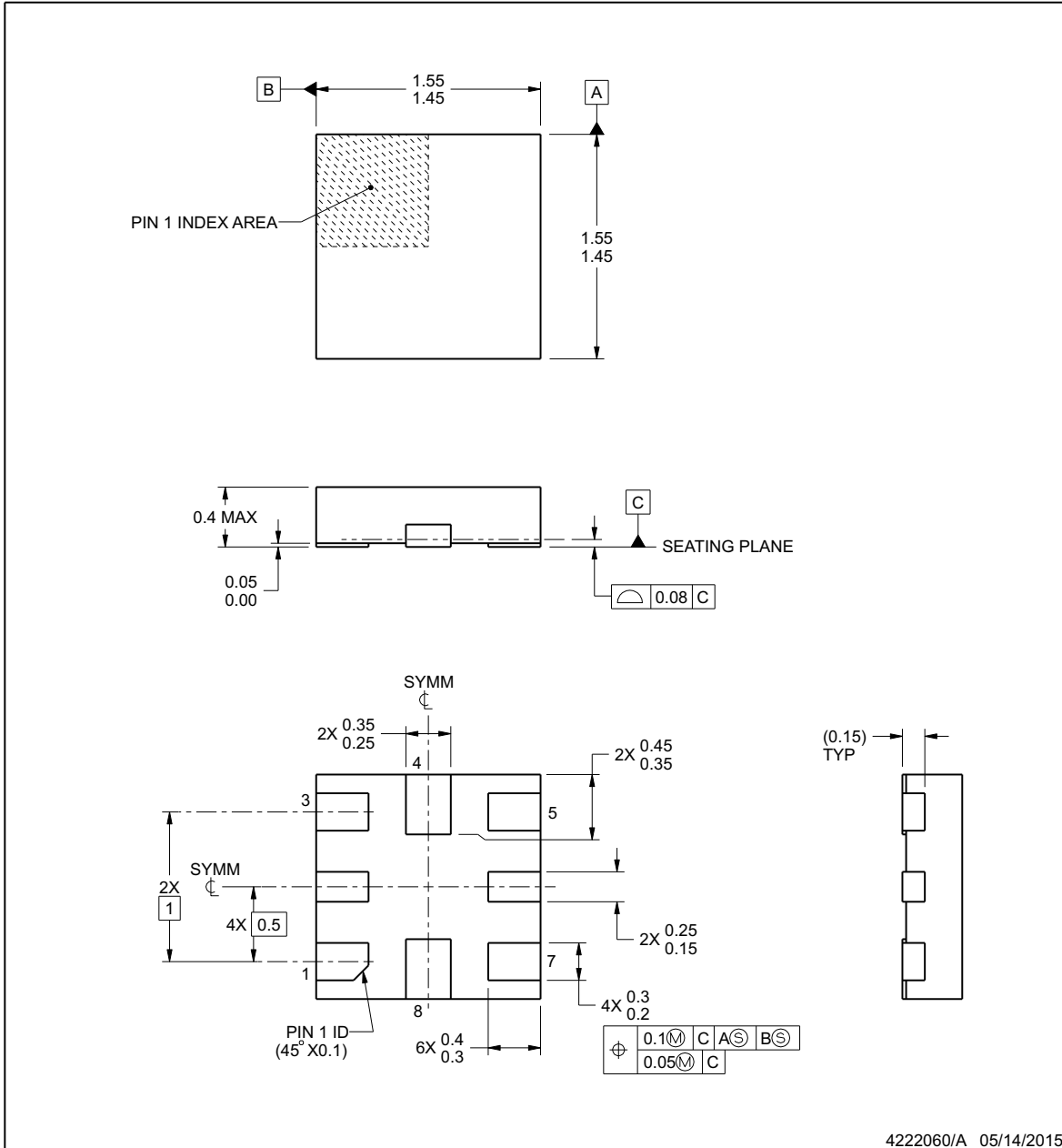

4222060/A 05/14/2015

NOTES:

1. All linear dimensions are in millimeters. Any dimensions in parenthesis are for reference only. Dimensioning and tolerancing per ASME Y14.5M.
2. This drawing is subject to change without notice.

EXAMPLE BOARD LAYOUT

RUG0008A

X2QFN - 0.4 mm max height

PLASTIC QUAD FLATPACK - NO LEAD

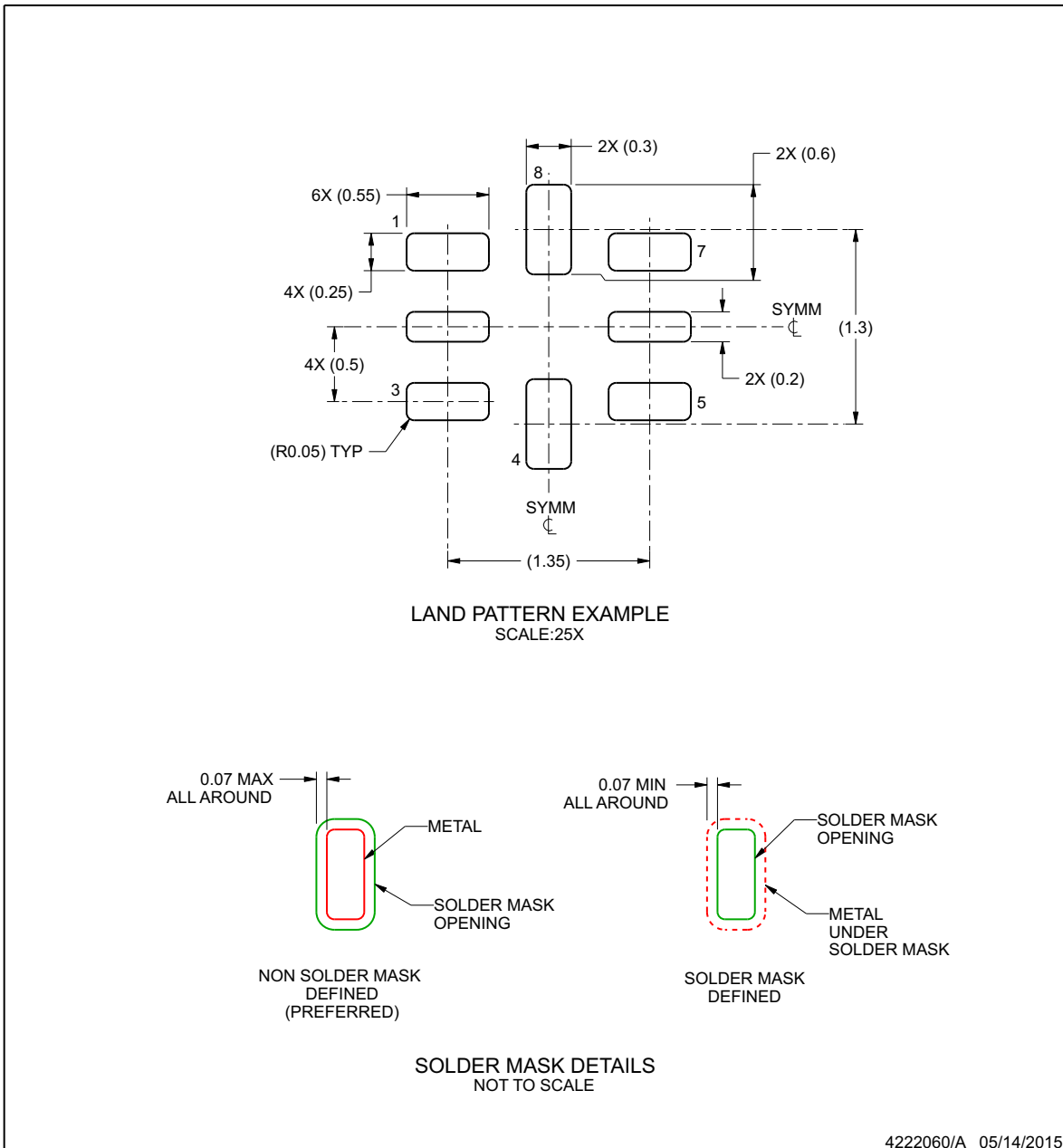

4222060/A 05/14/2015

NOTES: (continued)

3. For more information, see Texas Instruments literature number SLUA271 (www.ti.com/lit/slua271).

EXAMPLE STENCIL DESIGN

RUG0008A

X2QFN - 0.4 mm max height

PLASTIC QUAD FLATPACK - NO LEAD

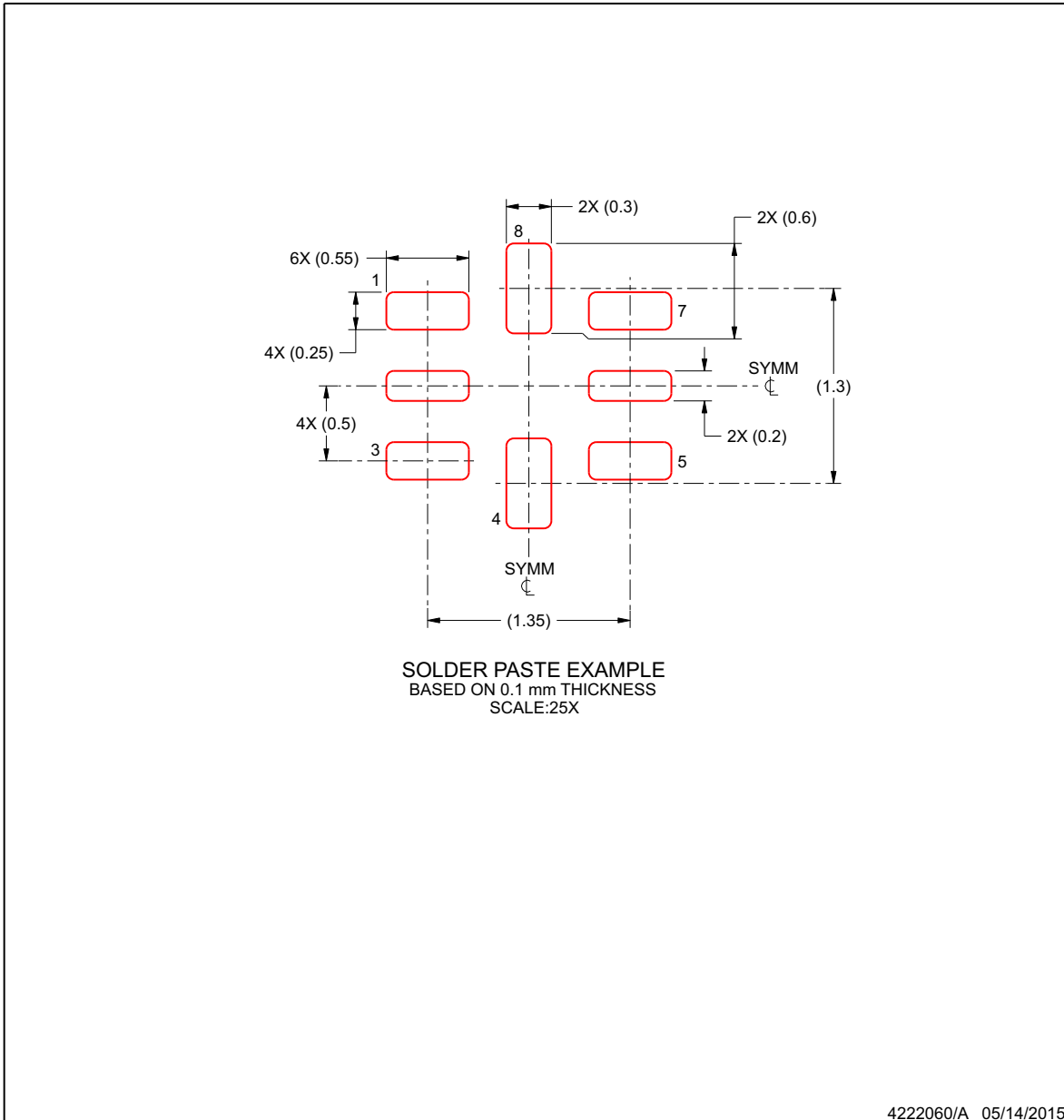

NOTES: (continued)

4. Laser cutting apertures with trapezoidal walls and rounded corners may offer better paste release. IPC-7525 may have alternate design recommendations.

重要声明

德州仪器(TI)及其下属子公司有权根据 JESD46 最新标准,对所提供的产品和服务进行更正、修改、增强、改进或其它更改,并有权根据 JESD48 最新标准中止提供任何产品和服务。客户在下订单前应获取最新的相关信息,并验证这些信息是否完整且是最新的。所有产品的销售都遵循在订单确认时所提供的TI 销售条款与条件。

TI 保证其所销售的组件的性能符合产品销售时 TI 半导体产品销售条件与条款的适用规范。仅在 TI 保证的范围内,且 TI 认为有必要时才会使用测试或其它质量控制技术。除非适用法律做出了硬性规定,否则没有必要对每种组件的所有参数进行测试。

TI 对应用帮助或客户产品设计不承担任何义务。客户应对其使用 TI 组件的产品和应用自行负责。为尽量减小与客户产品和应用相关的风险,客户应提供充分的设计与操作安全措施。

TI 不对任何 TI 专利权、版权、屏蔽作品权或其它与使用了 TI 组件或服务的组合设备、机器或流程相关的 TI 知识产权中授予的直接或隐含权限作出任何保证或解释。TI 所发布的与第三方产品或服务有关的信息,不能构成从 TI 获得使用这些产品或服务的许可、授权、或认可。使用此类信息可能需要获得第三方的专利权或其它知识产权方面的许可,或是 TI 的专利权或其它知识产权方面的许可。

对于 TI 的产品手册或数据表中 TI 信息的重要部分,仅在没有对内容进行任何篡改且带有相关授权、条件、限制和声明的情况下才允许进行复制。TI 对此类篡改过的文件不承担任何责任或义务。复制第三方的信息可能需要服从额外的限制条件。

在转售 TI 组件或服务时,如果对该组件或服务参数的陈述与 TI 标明的参数相比存在差异或虚假成分,则会失去相关 TI 组件或服务的所有明示或暗示授权,且这是不正当的、欺诈性商业行为。TI 对任何此类虚假陈述均不承担任何责任或义务。

客户认可并同意,尽管任何应用相关信息或支持仍可能由 TI 提供,但他们将独立负责满足与其产品及其在应用中使用的 TI 产品相关的所有法律、法规和安全相关要求。客户声明并同意,他们具备制定与实施安全措施所需的全部专业技术和知识,可预见故障的危险后果、监测故障及其后果、降低有可能造成人身伤害的故障的发生机率并采取适当的补救措施。客户将全额赔偿因在此类安全关键应用中使用任何 TI 组件而对 TI 及其代理造成的任何损失。

在某些场合中,为了推进安全相关应用有可能对 TI 组件进行特别的促销。TI 的目标是利用此类组件帮助客户设计和创立其特有的可满足适用的功能安全性标准和要求的终端产品解决方案。尽管如此,此类组件仍然服从这些条款。

TI 组件未获得用于 FDA Class III (或类似的生命攸关医疗设备)的授权许可,除非各方授权官员已经达成了专门管控此类使用的特别协议。

只有那些 TI 特别注明属于军用等级或“增强型塑料”的 TI 组件才是设计或专门用于军事/航空应用或环境的。购买者认可并同意,对并非指定面向军事或航空航天用途的 TI 组件进行军事或航空航天方面的应用,其风险由客户单独承担,并且由客户独立负责满足与此类使用相关的所有法律和法规要求。

TI 已明确指定符合 ISO/TS16949 要求的产品,这些产品主要用于汽车。在任何情况下,因使用非指定产品而无法达到 ISO/TS16949 要求, TI 不承担任何责任。

	产品		应用
数字音频	www.ti.com.cn/audio	通信与电信	www.ti.com.cn/telecom
放大器和线性器件	www.ti.com.cn/amplifiers	计算机及周边	www.ti.com.cn/computer
数据转换器	www.ti.com.cn/dataconverters	消费电子	www.ti.com.cn/consumer-apps
DLP® 产品	www.dlp.com	能源	www.ti.com.cn/energy
DSP - 数字信号处理器	www.ti.com.cn/dsp	工业应用	www.ti.com.cn/industrial
时钟和计时器	www.ti.com.cn/clockandtimers	医疗电子	www.ti.com.cn/medical
接口	www.ti.com.cn/interface	安防应用	www.ti.com.cn/security
逻辑	www.ti.com.cn/logic	汽车电子	www.ti.com.cn/automotive
电源管理	www.ti.com.cn/power	视频和影像	www.ti.com.cn/video
微控制器 (MCU)	www.ti.com.cn/microcontrollers		
RFID 系统	www.ti.com.cn/rfidsys		
OMAP应用处理器	www.ti.com/omap		
无线连通性	www.ti.com.cn/wirelessconnectivity	德州仪器在线技术支持社区	www.deyisupport.com

邮寄地址: 上海市浦东新区世纪大道1568号, 中建大厦32楼邮政编码: 200122
Copyright © 2016, 德州仪器半导体技术(上海)有限公司

PACKAGING INFORMATION

Orderable Device	Status (1)	Package Type	Package Drawing	Pins	Package Qty	Eco Plan (2)	Lead finish/ Ball material (6)	MSL Peak Temp (3)	Op Temp (°C)	Device Marking (4/5)	Samples
ADS7042IDCUR	ACTIVE	VSSOP	DCU	8	3000	RoHS & Green	NIPDAU	Level-1-260C-UNLIM	-40 to 125	7042	Samples
ADS7042IDCUT	ACTIVE	VSSOP	DCU	8	250	RoHS & Green	NIPDAU	Level-1-260C-UNLIM	-40 to 125	7042	Samples
ADS7042IRUGR	ACTIVE	X2QFN	RUG	8	3000	RoHS & Green	NIPDAUAG	Level-1-260C-UNLIM	-40 to 125	FV	Samples

(1) The marketing status values are defined as follows:

ACTIVE: Product device recommended for new designs.

LIFEBUY: TI has announced that the device will be discontinued, and a lifetime-buy period is in effect.

NRND: Not recommended for new designs. Device is in production to support existing customers, but TI does not recommend using this part in a new design.

PREVIEW: Device has been announced but is not in production. Samples may or may not be available.

OBSOLETE: TI has discontinued the production of the device.

(2) **RoHS:** TI defines "RoHS" to mean semiconductor products that are compliant with the current EU RoHS requirements for all 10 RoHS substances, including the requirement that RoHS substance do not exceed 0.1% by weight in homogeneous materials. Where designed to be soldered at high temperatures, "RoHS" products are suitable for use in specified lead-free processes. TI may reference these types of products as "Pb-Free".

RoHS Exempt: TI defines "RoHS Exempt" to mean products that contain lead but are compliant with EU RoHS pursuant to a specific EU RoHS exemption.

Green: TI defines "Green" to mean the content of Chlorine (Cl) and Bromine (Br) based flame retardants meet JS709B low halogen requirements of <=1000ppm threshold. Antimony trioxide based flame retardants must also meet the <=1000ppm threshold requirement.

(3) MSL, Peak Temp. - The Moisture Sensitivity Level rating according to the JEDEC industry standard classifications, and peak solder temperature.

(4) There may be additional marking, which relates to the logo, the lot trace code information, or the environmental category on the device.

(5) Multiple Device Markings will be inside parentheses. Only one Device Marking contained in parentheses and separated by a "~" will appear on a device. If a line is indented then it is a continuation of the previous line and the two combined represent the entire Device Marking for that device.

(6) Lead finish/Ball material - Orderable Devices may have multiple material finish options. Finish options are separated by a vertical ruled line. Lead finish/Ball material values may wrap to two lines if the finish value exceeds the maximum column width.

Important Information and Disclaimer:The information provided on this page represents TI's knowledge and belief as of the date that it is provided. TI bases its knowledge and belief on information provided by third parties, and makes no representation or warranty as to the accuracy of such information. Efforts are underway to better integrate information from third parties. TI has taken and continues to take reasonable steps to provide representative and accurate information but may not have conducted destructive testing or chemical analysis on incoming materials and chemicals. TI and TI suppliers consider certain information to be proprietary, and thus CAS numbers and other limited information may not be available for release.

In no event shall TI's liability arising out of such information exceed the total purchase price of the TI part(s) at issue in this document sold by TI to Customer on an annual basis.

TAPE AND REEL INFORMATION



QUADRANT ASSIGNMENTS FOR PIN 1 ORIENTATION IN TAPE



*All dimensions are nominal

Device	Package Type	Package Drawing	Pins	SPQ	Reel Diameter (mm)	Reel Width W1 (mm)	A0 (mm)	B0 (mm)	K0 (mm)	P1 (mm)	W (mm)	Pin1 Quadrant
ADS7042IDCUR	VSSOP	DCU	8	3000	180.0	8.4	2.25	3.35	1.05	4.0	8.0	Q3
ADS7042IDCUT	VSSOP	DCU	8	250	180.0	8.4	2.25	3.35	1.05	4.0	8.0	Q3
ADS7042IRUGR	X2QFN	RUG	8	3000	180.0	8.4	1.6	1.6	0.66	4.0	8.0	Q2

TAPE AND REEL BOX DIMENSIONS

*All dimensions are nominal

Device	Package Type	Package Drawing	Pins	SPQ	Length (mm)	Width (mm)	Height (mm)
ADS7042IDCUR	VSSOP	DCU	8	3000	202.0	201.0	28.0
ADS7042IDCUT	VSSOP	DCU	8	250	202.0	201.0	28.0
ADS7042IRUGR	X2QFN	RUG	8	3000	202.0	201.0	28.0

DCU (S-PDSO-G8)

PLASTIC SMALL OUTLINE PACKAGE (DIE DOWN)

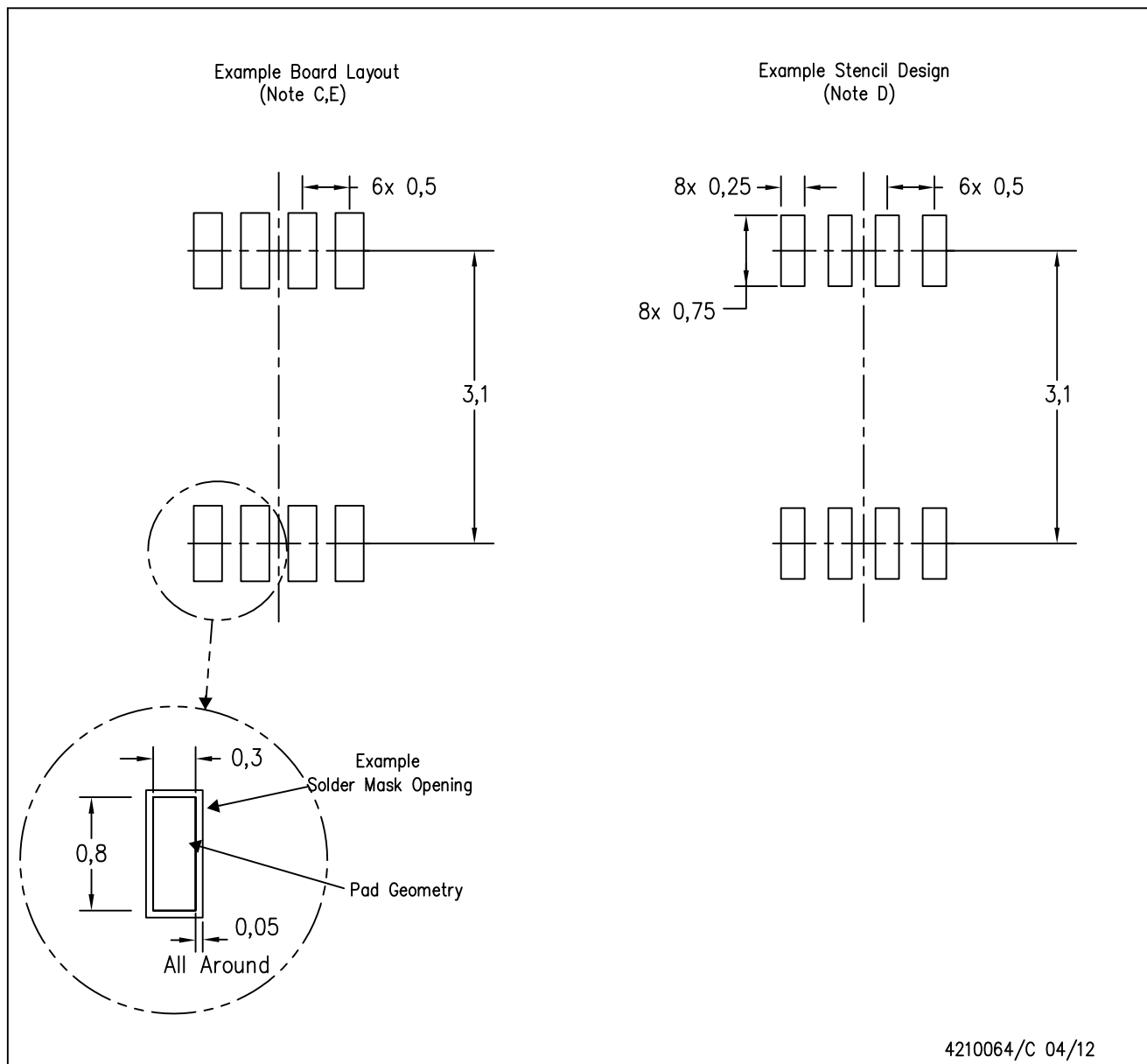

4210064/C 04/12

- NOTES:
- A. All linear dimensions are in millimeters.
 - B. This drawing is subject to change without notice.
 - C. Publication IPC-7351 is recommended for alternate designs.
 - D. Laser cutting apertures with trapezoidal walls and also rounding corners will offer better paste release. Customers should contact their board assembly site for stencil design recommendations. Refer to IPC-7525 for other stencil recommendations.
 - E. Customers should contact their board fabrication site for solder mask tolerances between and around signal pads.

重要声明和免责声明

TI 均以“原样”提供技术性及其可靠性数据（包括数据表）、设计资源（包括参考设计）、应用或其他设计建议、网络工具、安全信息和其他资源，不保证其中不含任何瑕疵，且不做任何明示或暗示的担保，包括但不限于对适销性、适合某特定用途或不侵犯任何第三方知识产权的暗示担保。

所述资源可供专业开发人员应用TI 产品进行设计使用。您将对以下行为独自承担全部责任：(1) 针对您的应用选择合适的TI 产品；(2) 设计、验证并测试您的应用；(3) 确保您的应用满足相应标准以及任何其他安全、安保或其他要求。所述资源如有变更，恕不另行通知。TI 对您使用所述资源的授权仅限于开发资源所涉及TI 产品的相关应用。除此之外不得复制或展示所述资源，也不提供其它TI 或任何第三方的知识产权授权许可。如因使用所述资源而产生任何索赔、赔偿、成本、损失及债务等，TI 对此概不负责，并且您须赔偿由此对TI 及其代表造成的损害。

TI 所提供产品均受TI 的销售条款 (<http://www.ti.com.cn/zh-cn/legal/termsofsale.html>) 以及 [ti.com.cn](http://www.ti.com.cn) 上或随附TI 产品提供的其他可适用条款的约束。TI 提供所述资源并不扩展或以其他方式更改TI 针对TI 产品所发布的可适用的担保范围或担保免责声明。

邮寄地址：上海市浦东新区世纪大道 1568 号中建大厦 32 楼，邮政编码：200122
Copyright © 2020 德州仪器半导体技术（上海）有限公司