

# Single Cell Li-Ion Battery Fuel Gauge for Battery Pack Integration

Check for Samples: [bq27541](#)

## FEATURES

- **Battery Fuel Gauge for 1-Series Li-Ion Applications**
- **Microcontroller Peripheral Provides:**
  - **Accurate Battery Fuel Gauging**
  - **Internal Temperature Sensor for System Temperature Reporting**
  - **SHA-1/HMAC Authentication**
  - **96 Bytes of Non-Volatile Scratch Pad FLASH**
- **Battery Fuel Gauging Based on Patented Impedance Track™ Technology**
  - **Models Battery Discharge Curve for Accurate Time-To-Empty Predictions**
  - **Automatically Adjusts for Battery Aging, Battery Self-Discharge, and Temperature/Rate Inefficiencies**
  - **Low-Value Sense Resistor (5 mΩ to 20 mΩ)**
- **HDQ and I<sup>2</sup>C™ Interface Formats for Communication with Host System**
- **Small 12-pin 2,5 mm × 4 mm SON Package**

## APPLICATIONS

- **Smartphones**
- **PDA's**
- **Digital Still and Video Cameras**
- **Handheld Terminals**
- **MP3 or Multimedia Players**

## DESCRIPTION

The Texas Instruments bq27541 Li-Ion battery fuel gauge is a microcontroller peripheral that provides fuel gauging for single-cell Li-Ion battery packs. The device requires little system microcontroller firmware development for accurate battery fuel gauging. The bq27541 resides within the battery pack or on the system's main-board with an embedded battery (nonremovable).

The bq27541 uses the patented Impedance Track™ algorithm for fuel gauging, and provides information such as remaining battery capacity (mAh), state-of-charge (%), run-time to empty (min.), battery voltage (mV), and temperature (°C).

The bq27541 also features integrated support for secure battery pack authentication, using the SHA-1/HMAC authentication algorithm.

## TYPICAL APPLICATION

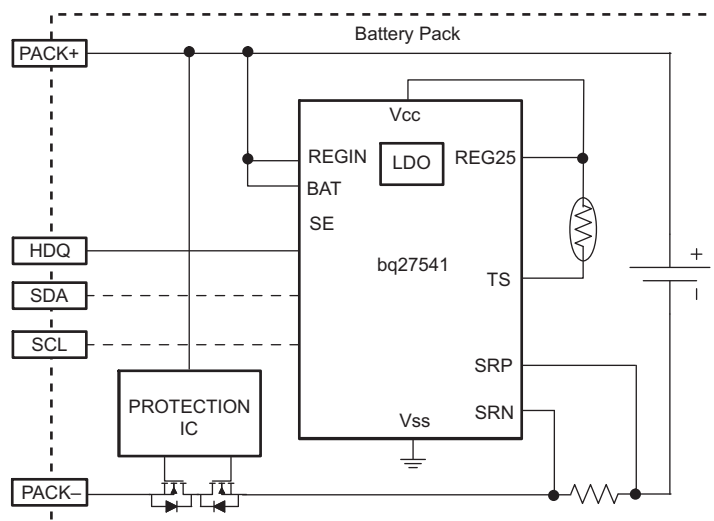

Please be aware that an important notice concerning availability, standard warranty, and use in critical applications of Texas Instruments semiconductor products and disclaimers thereto appears at the end of this data sheet.

Impedance Track is a trademark of Texas Instruments.

I<sup>2</sup>C is a trademark of Phillips Corporation.

PRODUCTION DATA information is current as of publication date. Products conform to specifications per the terms of the Texas Instruments standard warranty. Production processing does not necessarily include testing of all parameters.

Copyright © 2008, Texas Instruments Incorporated



This integrated circuit can be damaged by ESD. Texas Instruments recommends that all integrated circuits be handled with appropriate precautions. Failure to observe proper handling and installation procedures can cause damage.

ESD damage can range from subtle performance degradation to complete device failure. Precision integrated circuits may be more susceptible to damage because very small parametric changes could cause the device not to meet its published specifications.

## DEVICE INFORMATION

### AVAILABLE OPTIONS

PART NUMBER	PACKAGE	TA	COMMUNICATION FORMAT	TAPE and REEL QUANTITY
bq27541DRZR	12-pin, 2,5-mm x 4-mm SON	–40°C to 85°C	I2C, HDQ <sup>(1)</sup>	3000
bq27541DRZT				250

(1) bq27541 is shipped in I2C mode

**bq27541  
(TOP VIEW)**

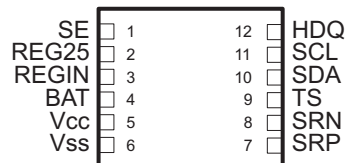

### TERMINAL FUNCTIONS

TERMINAL			DESCRIPTION
NAME	NO.	TYPE <sup>(1)</sup>	
BAT	4	I	Cell-voltage measurement input. ADC input. Decouple with 0.1μF capacitor.
REG25	2	P	2.5V output voltage of the internal integrated LDO. Connect a minimum 0.47μF ceramic capacitor.
REGIN	3	P	The input voltage for the internal integrated LDO. Connect a 0.1μF ceramic capacitor.
SCL	11	I	Slave I <sup>2</sup> C serial communications clock input line for communication with system (Slave). Use with 10 kΩ pull-up resistor (typical).
SDA	10	I/O	Slave I <sup>2</sup> C serial communications data line for communication with system (Slave). Open-drain I/O. Use with 10 kΩ pull-up resistor (typical).
SE	1	O	Shutdown Enable output. Open-drain.
HDQ	12	I/O	HDQ serial communications line (Slave). Open-drain.
SRN	8	IA	Analog input pin connected to the internal coulomb counter where SRN is nearest the PACK- connection. Connect to 5-mΩ to 20-mΩ sense resistor.
SRP	7	IA	Analog input pin connected to the internal coulomb counter where SRP is nearest the CELL- connection. Connect to 5-mΩ to 20-mΩ sense resistor
TS	9	IA	Pack thermistor voltage sense (use 103AT-type thermistor). ADC input
Vcc	5	P	Processor power input. The minimum 0.47μF capacitor connected to REG25 should be close to Vcc.
Vss	6	P	Device ground

(1) I/O = Digital input/output, IA = Analog input, P = Power connection

## ELECTRICAL SPECIFICATIONS

### ABSOLUTE MAXIMUM RATINGS

over operating free-air temperature range (unless otherwise noted)<sup>(1)</sup>

		VALUE	UNIT
V <sub>I</sub>	Regulator input, REGIN	-0.3 to 24	V
V <sub>CC</sub>	Supply voltage range	-0.3 to 2.75	V
V <sub>IOD</sub>	Open-drain I/O pins (SDA, SCL, HDQ)	-0.3 to 6	V
V <sub>BAT</sub>	BAT input, (pin 4)	-0.3 to 6	V
V <sub>I</sub>	Input voltage range to all others (pins 1, 7, 8, 9)	-0.3 to V <sub>CC</sub> + 0.3	V
ESD	Human Body Model (HBM), BAT pin	1.5	kV
	Human Body Model (HBM), all pins	2	
T <sub>F</sub>	Functional temperature range	-40 to 100	°C
T <sub>stg</sub>	Storage temperature range	-65 to 150	°C

- (1) Stresses beyond those listed under absolute maximum ratings may cause permanent damage to the device. These are stress ratings only, and functional operation of the device at these or any other conditions beyond those indicated under recommended operating conditions is not implied. Exposure to absolute-maximum-rated conditions for extended periods may affect device reliability.

### DISSIPATION RATINGS

PACKAGE <sup>(1)</sup>	T <sub>A</sub> ≤ 40°C POWER RATING	DERATING FACTOR T <sub>A</sub> ≤ 40°C	R <sub>θJA</sub>
12-pin DRZ <sup>(2)</sup>	482 mW	5.67 mW/°C	176°C/W

- (1) For the most current package and ordering information, see the Package Option Addendum at the end of this document, or see the TI website at [www.ti.com](http://www.ti.com).
- (2) This data is based on using a 4-layer JEDEC high-K board with the exposed die pad connected to a Cu pad on the board. The board pad is connected to the ground plane by a 2- x 2-via matrix.

### RECOMMENDED OPERATING CONDITIONS

T<sub>A</sub> = -40°C to 85°C; typical values at T<sub>A</sub> = 25°C and V<sub>(REGIN)</sub> = V<sub>BAT</sub> = 3.6 V (unless otherwise noted)

PARAMETER	Test CONDITION	MIN	TYP	MAX	UNIT
V <sub>I</sub>	Supply voltage, REGIN	2.7		5.5	V
	No operating restrictions				
I <sub>CC</sub>	Normal operating mode current <sup>(1)</sup>	Fuel gauge in NORMAL mode. I <sub>LOAD</sub> > <b>Sleep Current</b>	131		μA
I <sub>(SLP)</sub>	Low-power operating mode current <sup>(1)</sup>	Fuel gauge in SLEEP mode. I <sub>LOAD</sub> < <b>Sleep Current</b>	60		μA
I <sub>(FULLSLP)</sub>	Low-power operating mode current <sup>(1)</sup>	Fuel gauge in FULLSLEEP mode. I <sub>LOAD</sub> < <b>Sleep Current</b>	21		μA
I <sub>(HIB)</sub>	Hibernate operating mode current <sup>(1)</sup>	Fuel gauge in HIBERNATE mode. I <sub>LOAD</sub> < <b>Hibernate Current</b>	6		μA
V <sub>OL</sub>	Output voltage low (HDQ, SDA, SCL, SE)	I <sub>OL</sub> = 3 mA		0.4	V
V <sub>OH(PP)</sub>	Output high voltage (SE)	I <sub>OH</sub> = -1 mA	V <sub>CC</sub> -0.5		V
V <sub>OH(OD)</sub>	Output high voltage (HDQ, SDA, SCL)	External pull-up resistor connected to V <sub>CC</sub>	V <sub>CC</sub> -0.5		V
V <sub>IL</sub>	Input voltage low (HDQ, SDA, SCL)		-0.3	0.6	V
V <sub>IH</sub>	Input voltage high (HDQ, SDA, SCL)		1.2	6	V
V <sub>(A1)</sub>	Input voltage range (TS)		V <sub>SS</sub> -0.125	2	V
V <sub>(A2)</sub>	Input voltage range (BAT)		V <sub>SS</sub> -0.125	5	V
V <sub>(A3)</sub>	Input voltage range (SRP, SRN)		V <sub>SS</sub> -0.125	0.125	V
I <sub>ikg</sub>	Input leakage current (I/O pins)			0.3	μA
t <sub>PUCD</sub>	Power-up communication delay		250		ms

- (1) Specified by design. Not tested in production.

## POWER-ON RESET

$T_A = -40^\circ\text{C}$  to  $85^\circ\text{C}$ ,  $C_{(\text{REG})} = 0.47\ \mu\text{F}$ ,  $2.45\ \text{V} < V_{(\text{REGIN})} = V_{\text{BAT}} < 5.5\ \text{V}$ ; typical values at  $T_A = 25^\circ\text{C}$  and  $V_{(\text{REGIN})} = V_{\text{BAT}} = 3.6\ \text{V}$  (unless otherwise noted)

PARAMETER	TEST CONDITIONS	MIN	TYP	MAX	UNIT
$V_{\text{IT+}}$ Positive-going battery voltage input at $V_{\text{CC}}$		2.05	2.20	2.31	V
$V_{\text{HYS}}$ Power-on reset hysteresis		45	115	185	mV

## 2.5 V LDO REGULATOR<sup>(1)</sup>

$T_A = -40^\circ\text{C}$  to  $85^\circ\text{C}$ ,  $C_{(\text{REG})} = 0.47\ \mu\text{F}$ ,  $2.45\ \text{V} < V_{(\text{REGIN})} = V_{\text{BAT}} < 5.5\ \text{V}$ ; typical values at  $T_A = 25^\circ\text{C}$  and  $V_{(\text{REGIN})} = V_{\text{BAT}} = 3.6\ \text{V}$  (unless otherwise noted)

PARAMETER	TEST CONDITION	MIN	NOM	MAX	UNIT	
$V_{\text{O}}$ Regulator output voltage, REG25	$2.7\ \text{V} \leq V_{(\text{REGIN})} \leq 5.5\ \text{V}$ , $I_{\text{OUT}} \leq 16\ \text{mA}$	$T_A = -40^\circ\text{C}$ to $85^\circ\text{C}$	2.42	2.48	2.57	V
	$2.45\ \text{V} \leq V_{(\text{REGIN})} < 2.7\ \text{V}$ (low battery), $I_{\text{OUT}} \leq 3\ \text{mA}$	$T_A = -40^\circ\text{C}$ to $85^\circ\text{C}$	2.4			V
$V_{\text{DO}}$ Regulator dropout voltage	$2.7\ \text{V}$ , $I_{\text{OUT}} \leq 16\ \text{mA}$	$T_A = -40^\circ\text{C}$ to $85^\circ\text{C}$			280	mV
	$2.45\ \text{V}$ , $I_{\text{OUT}} \leq 3\ \text{mA}$				50	
$\Delta V_{(\text{REGTEMP})}$ Regulator output change with temperature	$V_{(\text{REGIN})} = 3.6\ \text{V}$ , $I_{\text{OUT}} = 16\ \text{mA}$	$T_A = -40^\circ\text{C}$ to $85^\circ\text{C}$	0.3%			
$\Delta V_{(\text{REGLINE})}$ Line regulation	$2.7\ \text{V} \leq V_{(\text{REGIN})} \leq 5.5\ \text{V}$ , $I_{\text{OUT}} = 16\ \text{mA}$		11	25	mV	
$\Delta V_{(\text{REGLOAD})}$ Load regulation	$0.2\ \text{mA} \leq I_{\text{OUT}} \leq 3\ \text{mA}$ , $V_{(\text{REGIN})} = 2.45\ \text{V}$		34	40	mV	
	$3\ \text{mA} \leq I_{\text{OUT}} \leq 16\ \text{mA}$ , $V_{(\text{REGIN})} = 2.7\ \text{V}$		31			
$I_{\text{OS}}^{(2)}$ Short circuit current limit	$V_{(\text{REG25})} = 0\ \text{V}$ , $T_A = -40^\circ\text{C}$ to $85^\circ\text{C}$			250	mA	

(1) LDO output current,  $I_{\text{OUT}}$ , is the sum of internal and external load currents.

(2) Specified by design. Not production tested.

## INTERNAL TEMPERATURE SENSOR CHARACTERISTICS

$T_A = -40^\circ\text{C}$  to  $85^\circ\text{C}$ ,  $C_{(\text{REG})} = 0.47\ \mu\text{F}$ ,  $2.45\ \text{V} < V_{(\text{REGIN})} = V_{\text{BAT}} < 5.5\ \text{V}$ ; typical values at  $T_A = 25^\circ\text{C}$  and  $V_{(\text{REGIN})} = V_{\text{BAT}} = 3.6\ \text{V}$  (unless otherwise noted)

PARAMETER	TEST CONDITIONS	MIN	TYP	MAX	UNIT
$G_{(\text{TEMP})}$ Temperature sensor voltage gain			-2		mV/°C

## HIGH FREQUENCY OSCILLATOR

$T_A = -40^\circ\text{C}$  to  $85^\circ\text{C}$ ,  $C_{(\text{REG})} = 0.47\ \mu\text{F}$ ,  $2.45\ \text{V} < V_{(\text{REGIN})} = V_{\text{BAT}} < 5.5\ \text{V}$ ; typical values at  $T_A = 25^\circ\text{C}$  and  $V_{(\text{REGIN})} = V_{\text{BAT}} = 3.6\ \text{V}$  (unless otherwise noted)

PARAMETER	TEST CONDITIONS	MIN	TYP	MAX	UNIT
$f_{\text{OSC}}$ Operating frequency			2.097		MHz
$f_{\text{EIO}}$ Frequency error <sup>(1) (2)</sup>	$T_A = 0^\circ\text{C}$ to $60^\circ\text{C}$	-2.0%	0.38%	2.0%	
	$T_A = -20^\circ\text{C}$ to $70^\circ\text{C}$	-3.0%	0.38%	3.0%	
	$T_A = -40^\circ\text{C}$ to $85^\circ\text{C}$	-4.5%	0.38%	4.5%	
$t_{\text{SXO}}$ Start-up time <sup>(3)</sup>			2.5	5	ms

(1) The frequency error is measured from 2.097 MHz.

(2) The frequency drift is included and measured from the trimmed frequency at  $V_{\text{CC}} = 2.5\ \text{V}$ ,  $T_A = 25^\circ\text{C}$ .

(3) The startup time is defined as the time it takes for the oscillator output frequency to be  $\pm 3\%$  of typical oscillator frequency.

## LOW FREQUENCY OSCILLATOR

$T_A = -40^\circ\text{C}$  to  $85^\circ\text{C}$ ,  $C_{(\text{REG})} = 0.47\mu\text{F}$ ,  $2.45\text{ V} < V_{(\text{REGIN})} = V_{\text{BAT}} < 5.5\text{ V}$ ; typical values at  $T_A = 25^\circ\text{C}$  and  $V_{(\text{REGIN})} = V_{\text{BAT}} = 3.6\text{ V}$  (unless otherwise noted)

PARAMETER		TEST CONDITIONS	MIN	TYP	MAX	UNIT
$f_{\text{OSC}}$	Operating frequency			32.768		KHz
$f_{\text{EIO}}$	Frequency error <sup>(1)</sup> (2)	$T_A = 0^\circ\text{C}$ to $60^\circ\text{C}$	-1.5%	0.25%	1.5%	
		$T_A = -20^\circ\text{C}$ to $70^\circ\text{C}$	-2.5%	0.25%	2.5%	
		$T_A = -40^\circ\text{C}$ to $85^\circ\text{C}$	-4.0%	0.25%	4.0%	
$t_{\text{SXO}}$	Start-up time <sup>(3)</sup>			500		$\mu\text{s}$

(1) The frequency drift is included and measured from the trimmed frequency at  $V_{\text{CC}} = 2.5\text{ V}$ ,  $T_A = 25^\circ\text{C}$ .

(2) The frequency error is measured from 32.768 KHz.

(3) The startup time is defined as the time it takes for the oscillator output frequency to be  $\pm 3\%$  of typical oscillator frequency.

## INTEGRATING ADC (COULOMB COUNTER) CHARACTERISTICS

$T_A = -40^\circ\text{C}$  to  $85^\circ\text{C}$ ,  $C_{(\text{REG})} = 0.47\mu\text{F}$ ,  $2.45\text{ V} < V_{(\text{REGIN})} = V_{\text{BAT}} < 5.5\text{ V}$ ; typical values at  $T_A = 25^\circ\text{C}$  and  $V_{(\text{REGIN})} = V_{\text{BAT}} = 3.6\text{ V}$  (unless otherwise noted)

PARAMETER		TEST CONDITIONS	MIN	TYP	MAX	UNIT
$V_{\text{IN}(\text{SR})}$	Input voltage range, $V_{(\text{SRN})}$ and $V_{(\text{SRP})}$	$V_{\text{SR}} = V_{(\text{SRN})} - V_{(\text{SRP})}$	-0.125		0.125	V
$t_{\text{CONV}(\text{SR})}$	Conversion time	Single conversion		1		s
	Resolution		14		15	bits
$V_{\text{OS}(\text{SR})}$	Input offset			10		$\mu\text{V}$
$I_{\text{NL}}$	Integral nonlinearity error			$\pm 0.007$	$\pm 0.034$	FSR
$Z_{\text{IN}(\text{SR})}$	Effective input resistance <sup>(1)</sup>		2.5			M $\Omega$
$I_{\text{lk}(\text{SR})}$	Input leakage current <sup>(1)</sup>				0.3	$\mu\text{A}$

(1) Specified by design. Not production tested.

## ADC (TEMPERATURE AND CELL MEASUREMENT) CHARACTERISTICS

$T_A = -40^\circ\text{C}$  to  $85^\circ\text{C}$ ,  $C_{(\text{REG})} = 0.47\mu\text{F}$ ,  $2.45\text{ V} < V_{(\text{REGIN})} = V_{\text{BAT}} < 5.5\text{ V}$ ; typical values at  $T_A = 25^\circ\text{C}$  and  $V_{(\text{REGIN})} = V_{\text{BAT}} = 3.6\text{ V}$  (unless otherwise noted)

PARAMETER		TEST CONDITIONS	MIN	TYP	MAX	UNIT
$V_{\text{IN}(\text{ADC})}$	Input voltage range		-0.2		1	V
$t_{\text{CONV}(\text{ADC})}$	Conversion time				125	ms
	Resolution		14		15	bits
$V_{\text{OS}(\text{ADC})}$	Input offset			1		mV
$Z_{(\text{ADC}1)}$	Effective input resistance (TS) <sup>(1)</sup>		8			M $\Omega$
$Z_{(\text{ADC}2)}$	Effective input resistance (BAT) <sup>(1)</sup>	bq27541 not measuring cell voltage	8			M $\Omega$
		bq27541 measuring cell voltage		100		k $\Omega$
$I_{\text{lk}(\text{ADC})}$	Input leakage current <sup>(1)</sup>				0.3	$\mu\text{A}$

(1) Specified by design. Not production tested.

## DATA FLASH MEMORY CHARACTERISTICS

$T_A = -40^\circ\text{C}$  to  $85^\circ\text{C}$ ,  $C_{(\text{REG})} = 0.47\mu\text{F}$ ,  $2.45\text{ V} < V_{(\text{REGIN})} = V_{\text{BAT}} < 5.5\text{ V}$ ; typical values at  $T_A = 25^\circ\text{C}$  and  $V_{(\text{REGIN})} = V_{\text{BAT}} = 3.6\text{ V}$  (unless otherwise noted)

PARAMETER		TEST CONDITIONS	MIN	TYP	MAX	UNIT
$t_{\text{DR}}$	Data retention <sup>(1)</sup>		10			Years
	Flash programming write-cycles <sup>(1)</sup>		20,000			Cycles
$t_{\text{WORDPROG}}$	Word programming time <sup>(1)</sup>				2	ms
$I_{\text{CCPROG}}$	Flash-write supply current <sup>(1)</sup>			5	10	mA

(1) Specified by design. Not production tested.

### HDQ COMMUNICATION TIMING CHARACTERISTICS

$T_A = -40^{\circ}\text{C}$  to  $85^{\circ}\text{C}$ ,  $C_{REG} = 0.47\mu\text{F}$ ,  $2.45\text{ V} < V_{REGIN} = V_{BAT} < 5.5\text{ V}$ ; typical values at  $T_A = 25^{\circ}\text{C}$  and  $V_{REGIN} = V_{BAT} = 3.6\text{ V}$  (unless otherwise noted)

PARAMETER	TEST CONDITIONS	MIN	TYP	MAX	UNIT
$t_{(CYCH)}$	Cycle time, host to bq27541	190			$\mu\text{s}$
$t_{(CYCD)}$	Cycle time, bq27541 to host	190	205	250	$\mu\text{s}$
$t_{(HW1)}$	Host sends 1 to bq27541	0.5		50	$\mu\text{s}$
$t_{(DW1)}$	bq27541 sends 1 to host	32		50	$\mu\text{s}$
$t_{(HW0)}$	Host sends 0 to bq27541	86		145	$\mu\text{s}$
$t_{(DW0)}$	bq27541 sends 0 to host	80		145	$\mu\text{s}$
$t_{(RSPS)}$	Response time, bq27541 to host	190		320	$\mu\text{s}$
$t_{(B)}$	Break time	190			$\mu\text{s}$
$t_{(BR)}$	Break recovery time	40			$\mu\text{s}$

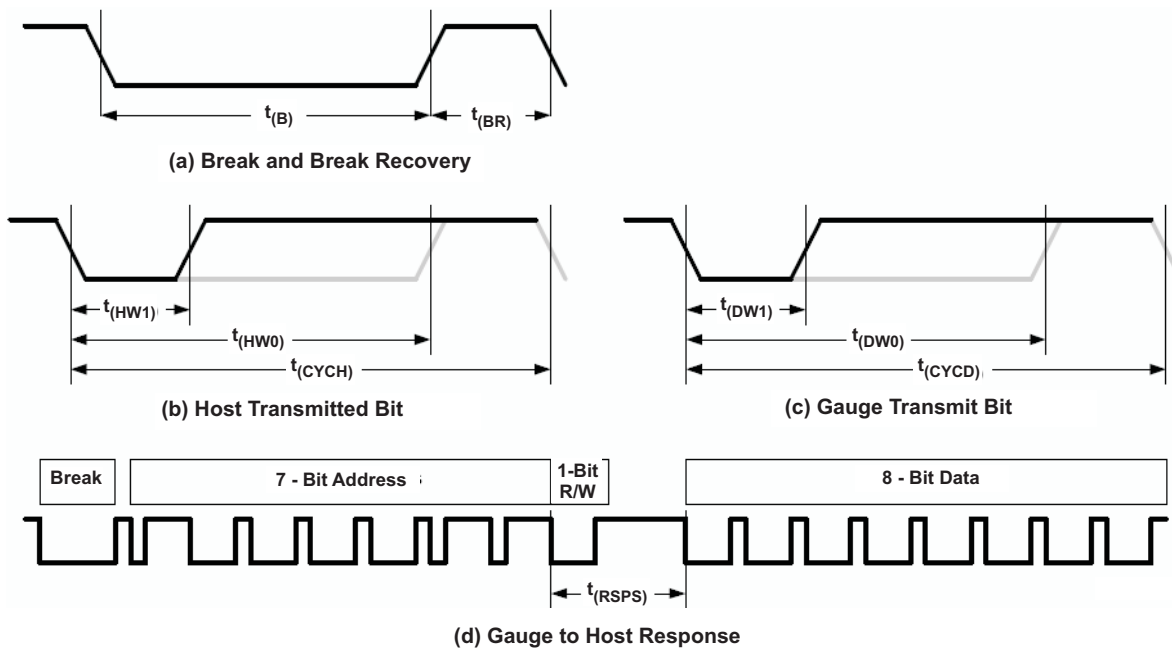

Figure 1. Timing Diagrams for HDQ Breaking (a), HDQ Host to bq27541 communication (b), bq27541 to Host communication (c), and bq27541 to Host response format (d).

## I<sup>2</sup>C-COMPATIBLE INTERFACE COMMUNICATION TIMING CHARACTERISTICS

$T_A = -40^{\circ}\text{C}$  to  $85^{\circ}\text{C}$ ,  $C_{\text{REG}} = 0.47\mu\text{F}$ ,  $2.45\text{ V} < V_{\text{REGIN}} = V_{\text{BAT}} < 5.5\text{ V}$ ; typical values at  $T_A = 25^{\circ}\text{C}$  and  $V_{\text{REGIN}} = V_{\text{BAT}} = 3.6\text{ V}$  (unless otherwise noted)

PARAMETER	TEST CONDITIONS	MIN	TYP	MAX	UNIT
$t_r$	SCL/SDA rise time			300	ns
$t_f$	SCL/SDA fall time			300	ns
$t_{w(H)}$	SCL pulse width (high)	600			ns
$t_{w(L)}$	SCL pulse width (low)	1.3			$\mu\text{s}$
$t_{\text{su(STA)}}$	Setup for repeated start	600			ns
$t_{\text{d(STA)}}$	Start to first falling edge of SCL	600			ns
$t_{\text{su(DAT)}}$	Data setup time	1000			ns
$t_{\text{h(DAT)}}$	Data hold time	0			ns
$t_{\text{su(STOP)}}$	Setup time for stop	600			ns
$t_{\text{BUF}}$	Bus free time between stop and start	1.3			$\mu\text{s}$
$f_{\text{SCL}}$	Clock frequency			400	kHz

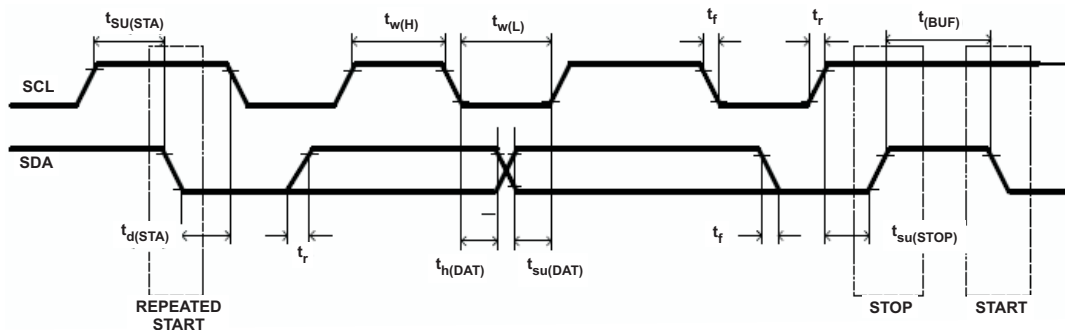

Figure 2. I<sup>2</sup>C-Compatible Interface Timing Diagrams

## GENERAL DESCRIPTION

The bq27541 accurately predicts the battery capacity and other operational characteristics of a single Li-based rechargeable cell. It can be interrogated by a system processor to provide cell information, such as state-of-charge (SOC), time-to-empty (TTE) and time-to-full (TTF).

Information is accessed through a series of commands, called *Standard Commands*. Further capabilities are provided by the additional *Extended Commands* set. Both sets of commands, indicated by the general format *Command()*, are used to read and write information contained within the bq27541 control and status registers, as well as its data flash locations. Commands are sent from system to gauge using the bq27541's serial communications engine, and can be executed during application development, pack manufacture, or end-equipment operation.

Cell information is stored in the bq27541 in non-volatile flash memory. Many of these data flash locations are accessible during application development. They cannot, generally, be accessed directly during end-equipment operation. Access to these locations is achieved by either use of the bq27541's companion evaluation software, through individual commands, or through a sequence of data-flash-access commands. To access a desired data flash location, the correct data flash subclass and offset must be known.

The bq27541 provides 96 bytes of user-programmable data flash memory, partitioned into 3 32-byte blocks: **Manufacturer Info Block A**, **Manufacturer Info Block B**, and **Manufacturer Info Block C**. This data space is accessed through a data flash interface. For specifics on accessing the data flash, see section *Manufacturer Information Blocks*. The key to the bq27541's high-accuracy gas gauging prediction is Texas Instrument's proprietary Impedance Track™ algorithm. This algorithm uses cell measurements, characteristics, and properties to create state-of-charge predictions that can achieve less than 1% error across a wide variety of operating conditions and over the lifetime of the battery.

The bq27541 measures charge/discharge activity by monitoring the voltage across a small-value series sense resistor (5 mΩ to 20 mΩ typ.) located between the CELL- and the battery's PACK- terminal. When a cell is attached to the bq27541, cell impedance is computed, based on cell current, cell open-circuit voltage (OCV), and cell voltage under loading conditions.

The bq27501 external temperature sensing is optimized with the use of a high accuracy negative temperature coefficient (NTC) thermistor with  $R_{25} = 10K\Omega \pm 1\%$  and  $B_{25/85} = 3435K\Omega \pm 1\%$  (such as Semitec 103AT for measurement). The bq27501 can also be configured to use its internal temperature sensor. The bq27541 uses temperature to monitor the battery-pack environment, which is used for fuel gauging and cell protection functionality.

To minimize power consumption, the bq27541 has different power modes: NORMAL, SLEEP, FULLSLEEP, HIBERNATE, and PRESHUTDOWN. The bq27541 passes automatically between these modes, depending upon the occurrence of specific events, though a system processor can initiate some of these modes directly. More details can be found in section *Power Modes*.

---

### NOTE

#### FORMATTING CONVENTIONS IN THIS DOCUMENT:

**Commands:** *italics* with *parentheses()* and no breaking spaces. e.g. *RemainingCapacity()*

**Data Flash:** *italics*, **bold**, and *breaking spaces*. e.g. **Design Capacity**

**Register bits and flags:** *italics* with *brackets[]*. e.g. *[TDA]*

**Data flash bits:** *italics*, **bold**, and *brackets[]*. e.g. **[LED1]**

**Modes and states:** ALL CAPITALS. e.g. UNSEALED mode

---

## STANDARD DATA COMMANDS

The bq27541 uses a series of 2-byte standard commands to enable system reading and writing of battery information. Each standard command has an associated command-code pair, as indicated in [Table 1](#). Because each command consists of two bytes of data, two consecutive I<sup>2</sup>C transmissions must be executed both to initiate the command function, and to read or write the corresponding two bytes of data. Additional options for transferring data, such as spooling, are described in Section I<sup>2</sup>C Interface. Standard commands are accessible in NORMAL operation.

**Table 1. Standard Commands**

NAME		COMMAND CODE	UNITS	SEALED ACCESS
<i>Control( )</i>	CNTL	0x00 / 0x01	N/A	R/W
<i>AtRate( )</i>	AR	0x02 / 0x03	mA	R/W
<i>AtRateTimeToEmpty( )</i>	ARTTE	0x04 / 0x05	Minutes	R
<i>Temperature( )</i>	TEMP	0x06 / 0x07	0.1K	R
<i>Voltage( )</i>	VOLT	0x08 / 0x09	mV	R
<i>Flags( )</i>	FLAGS	0x0a / 0x0b	N/A	R
<i>NominalAvailableCapacity( )</i>	NAC	0x0c / 0x0d	mAh	R
<i>FullAvailableCapacity( )</i>	FAC	0x0e / 0x0f	mAh	R
<i>RemainingCapacity( )</i>	RM	0x10 / 0x11	mAh	R
<i>FullChargeCapacity( )</i>	FCC	0x12 / 0x13	mAh	R
<i>AverageCurrent( )</i>	AI	0x14 / 0x15	mA	R
<i>TimeToEmpty( )</i>	TTE	0x16 / 0x17	Minutes	R
<i>TimeToFull( )</i>	TTF	0x18 / 0x19	Minutes	R
<i>StandbyCurrent( )</i>	SI	0x1a / 0x1b	mA	R
<i>StandbyTimeToEmpty( )</i>	STTE	0x1c / 0x1d	Minutes	R
<i>MaxLoadCurrent( )</i>	MLI	0x1e / 0x1f	mA	R
<i>MaxLoadTimeToEmpty( )</i>	MLTTE	0x20 / 0x21	Minutes	R
<i>AvailableEnergy( )</i>	AE	0x22 / 0x23	10 mWhr	R
<i>AveragePower( )</i>	AP	0x24 / 0x25	10 mW	R
<i>TTEatConstantPower( )</i>	TTECP	0x26 / 0x27	Minutes	R
Reserved	RSVD	0x28 / 0x29	N/A	R
<i>CycleCount( )</i>	CC	0x2a / 0x2b	Counts	R
<i>StateOfCharge( )</i>	SOC	0x2c / 0x2d	%	R

**Control( ): 0x00/0x01**

Issuing a *Control( )* command requires a subsequent 2-byte subcommand. These additional bytes specify the particular control function desired. The *Control( )* command allows the system to control specific features of the bq27541 during normal operation and additional features when the bq27541 is in different access modes, as described in [Table 2](#).

**Table 2. Control( ) Subcommands**

CNTL FUNCTION	CNTL DATA	SEALED ACCESS	DESCRIPTION
CONTROL_STATUS	0x0000	Yes	Reports the status of DF Checksum, Hibernate, IT, etc.
DEVICE_TYPE	0x0001	Yes	Reports the device type of 0x0541 (indicating bq27541)
FW_VERSION	0x0002	Yes	Reports the firmware version on the device type
HW_VERSION	0x0003	Yes	Reports the hardware version of the device type
DF_CHECKSUM	0x0004	No	Enables a data flash checksum to be generated and reports on a read
RESET_DATA	0x0005	No	Returns reset data
Reserved	0x0006	No	Not to be used
PREV_MACWRITE	0x0007	No	Returns previous MAC command code
CHEM_ID	0x0008	Yes	Reports the chemical identifier of the Impedance Track™ configuration
SET_FULLSLEEP	0x0010	Yes	Set the <i>[FullSleep]</i> bit in Control Status register to 1
SET_HIBERNATE	0x0011	Yes	Forces CONTROL_STATUS <i>[HIBERNATE]</i> to 1
CLEAR_HIBERNATE	0x0012	Yes	Forces CONTROL_STATUS <i>[HIBERNATE]</i> to 0
SET_SHUTDOWN	0x0013	Yes	Enables the SE pin to change state
CLEAR_SHUTDOWN	0x0014	Yes	Disables the SE pin from changing state
SEALED	0x0020	No	Places the bq27541 in SEALED access mode
IT_ENABLE	0x0021	No	Enables the Impedance Track™ algorithm
CAL_MODE	0x0040	No	Places the bq27541 in calibration mode
RESET	0x0041	No	Forces a full reset of the bq27541

**CONTROL\_STATUS: 0X0000**

Instructs the fuel gauge to return status information to Control addresses 0x00/0x01. The status word includes the following information.

**Table 3. CONTROL\_STATUS Bit Definitions**

	<b>bit7</b>	<b>bit6</b>	<b>bit5</b>	<b>bit4</b>	<b>bit3</b>	<b>bit2</b>	<b>bit1</b>	<b>bit0</b>
High Byte	SE	FAS	SS	CSV	CCA	BCA	–	–
Low Byte	SHUTDOWN	HIBERNATE	FULLSLEEP	SLEEP	LDMD	RUP_DIS	VOK	QEN

SE = Status bit indicating the SE pin is active. True when set (i.e. SE pin is low) . Default is 0.

FAS = Status bit indicating the bq27541 is in FULL ACCESS SEALED state. Active when set.

SS = Status bit indicating the bq27541 is in the SEALED State. Active when set.

CSV = Status bit indicating a valid data flash checksum has been generated. Active when set.

CCA = Status bit indicating the bq27541 Coulomb Counter Calibration routine is active. Active when set.

BCA = Status bit indicating the bq27541 Board Calibration routine is active. Active when set.

SHUTDOWN = Control bit indicating the fuel gauge can force its SE pin low to signal an external shutdown. True when set. Default is 0.

HIBERNATE = Status bit indicating a request for entry into HIBERNATE from SLEEP mode has been issued. True when set. Default is 0.

FULLSLEEP = Control bit when set will put the bq27541 into the lower power state of SLEEP mode. It is not possible to monitor this bit because any communication will automatically clear it. The state can be detected by monitoring the power used by the bq27541.

SLEEP = Status bit indicating the bq27541 is in SLEEP mode. True when set

LDMD = Status bit indicating the bq27541 Impedance Track™ algorithm using *constant-power* mode. True when set. Default is 0 (*constant-current* mode).

RUP\_DIS = Status bit indicating the bq27541 Ra table updates are disabled. True when set.

VOK = Status bit indicating cell voltages are OK for Qmax updates. True when set.

QEN = Status bit indicating the bq27541 Qmax updates are enabled. True when set.

**DEVICE\_TYPE: 0X0001**

Instructs the fuel gauge to return the device type to addresses 0x00/0x01.

**FW\_VERSION: 0X0002**

Instructs the fuel gauge to return the firmware version to addresses 0x00/0x01.

**HW\_VERSION: 0X0003**

Instructs the fuel gauge to return the hardware version to addresses 0x00/0x01.

**DF\_CHECKSUM: 0X0004**

Instructs the fuel gauge to compute the checksum of the data flash memory. The checksum value is written and returned to addresses 0x00/0x01 (UNSEALED mode only). The checksum will not be calculated in SEALED mode; however, the checksum value can still be read.

**RESET\_DATA: 0X0005**

Instructs the fuel gauge to return the reset data to addresses 0x00/0x01, with the low byte (0x00) being the number of full resets and the high byte (0x01) the number of partial resets.

**PREV\_MACWRITE: 0X0007**

Instructs the fuel gauge to return the previous command written to addresses 0x00/0x01.

**CHEM\_ID: 0X0008**

Instructs the fuel gauge to return the chemical identifier for the Impedance Track™ configuration to addresses 0x00/0x01.

**SET\_FULLSLEEP: 0X0010**

Instructs the gas gauge to set the FullSleep bit in Control Status register to 1. This will allow the gauge to enter the FULLSLEEP power mode after the transition to SLEEP power state is detected. In FullSleep mode less power is consumed by disabling an oscillator circuit used by the communication engines. For HDQ communication one host message will be dropped. For I2C communications the first I2C message will incur a 6 – 8 millisecond clock stretch while the oscillator is started and stabilized. A communication to the device in FULLSLEEP will force the part back to the SLEEP mode.

**SET\_HIBERNATE: 0X0011**

Instructs the fuel gauge to force the CONTROL\_STATUS [*HIBERNATE*] bit to 1. This will allow the gauge to enter the HIBERNATE power mode after the transition to SLEEP power state is detected. The [*HIBERNATE*] bit is automatically cleared upon exiting from HIBERNATE mode.

**CLEAR\_HIBERNATE: 0X0012**

Instructs the fuel gauge to force the CONTROL\_STATUS [*HIBERNATE*] bit to 0. This will prevent the gauge from entering the HIBERNATE power mode after the transition to SLEEP power state is detected. It can also be used to force the gauge out of HIBERNATE mode.

**SET\_SHUTDOWN: 0X0013**

Sets the CONTROL\_STATUS [*SHUTDOWN*] bit to 1, thereby enabling the SE pin and CONTROL\_STATUS [*SE*] bit to change state. The Impedance Track algorithm controls the setting of the SE pin and [*SE*] bit, depending on whether the conditions are met for fuel gauge shutdown or not.

**CLEAR\_SHUTDOWN: 0X0014**

Disables the SE pin from changing state. The SE pin is left in a high-impedance state.

**SEALED: 0X0020**

Instructs the fuel gauge to transition from UNSEALED state to SEALED state. The fuel gauge should always be set to SEALED state for use in end equipment.

**IT\_ENABLE: 0X0021**

This command forces the fuel gauge to begin the Impedance Track™ algorithm, sets the active **UpdateStatus** location to 0x01 and causes the [*VOK*] and [*QEN*] flags to be set in the CONTROL\_STATUS register. [*VOK*] is cleared if the voltages are not suitable for a Qmax update. Once set, [*QEN*] cannot be cleared. This command is only available when the fuel gauge is UNSEALED.

**CAL\_MODE:** 0X0040

This command instructs the fuel gauge to enter calibration mode. This command is only available when the fuel gauge is UNSEALED

**RESET :** 0X0041

This command instructs the fuel gauge to perform a full reset. This command is only available when the fuel gauge is UNSEALED.

***AtRate( ):* 0x02/0x03**

The *AtRate( )* read-/write-word function is the first half of a two-function command set used to set the *AtRate* value used in calculations made by the *AtRateTimeToEmpty( )* function. The *AtRate( )* units are in mA.

The *AtRate( )* value is a signed integer, with negative values interpreted as a discharge current value. The *AtRateTimeToEmpty( )* function returns the predicted operating time at the *AtRate* value of discharge. The default value for *AtRate( )* is zero and will force *AtRateTimeToEmpty( )* to return 65,535. Both the *AtRate( )* and *AtRateTimeToEmpty( )* commands should only be used in NORMAL mode.

***AtRateTimeToEmpty( ):* 0x04/0x05**

This read-only function returns an unsigned integer value of the predicted remaining operating time if the battery is discharged at the *AtRate( )* value in minutes with a range of 0 to 65,534. A value of 65,535 indicates *AtRate( )* = 0. The fuel gauge updates *AtRateTimeToEmpty( )* within 1 s after the system sets the *AtRate( )* value. The fuel gauge automatically updates *AtRateTimeToEmpty( )* based on the *AtRate( )* value every 1s. Both the *AtRate( )* and *AtRateTimeToEmpty( )* commands should only be used in NORMAL mode.

***Temperature( ):* 0x06/0x07**

This read-only function returns an unsigned integer value of the battery temperature in units of 0.1K measured by the fuel gauge.

***Voltage( ):* 0x08/0x09**

This read-only function returns an unsigned integer value of the measured cell-pack voltage in mV with a range of 0 to 6000 mV.

***Flags( ):* 0x0a/0x0b**

This read-only function returns the contents of the gas-gauge status register, depicting the current operating status.

**Table 4. Flags Bit Definitions**

	bit7	bit6	bit5	bit4	bit3	bit2	bit1	bit0
High Byte	OTC	OTD	–	–	CHG_INH	XCHG	FC	CHG
Low Byte	—	–	–	–	–	SOC1	SOCF	DSG

- OTC = Over-Temperature in Charge condition is detected. True when set
- OTD = Over-Temperature in Discharge condition is detected. True when set
- CHG\_INH = Charge Inhibit indicates the temperature is outside the range [*Charge Inhibit Temp Low, Charge Inhibit Temp High*]. True when set
- XCHG = Charge Suspend Alert indicates the temperature is outside the range [*Suspend Temperature Low, Suspend Temperature High*]. True when set
- FC = Full-charged condition reached (RMFCC=1; Set FC\_Set%=-1% when RMFCC=0). True when set
- CHG = (Fast) charging allowed. True when set
- SOC1 = State-of-Charge-Threshold 1 (**SOC1 Set**) reached. True when set
- SOCF = State-of-Charge-Threshold Final (**SOCF Set %**) reached. True when set
- DSG = Discharging detected. True when set

**NominalAvailableCapacity( ): 0x0c/0x0d**

This read-only command pair returns the uncompensated (less than C/20 load) battery capacity remaining. Units are mAh.

**FullAvailableCapacity( ): 0x0e/0x0f**

This read-only command pair returns the uncompensated (less than C/20 load) capacity of the battery when fully charged. Units are mAh. *FullAvailableCapacity( )* is updated at regular intervals, as specified by the IT algorithm.

**RemainingCapacity( ): 0x10/0x11**

This read-only command pair returns the compensated battery capacity remaining. Units are mAh.

**FullChargeCapacity( ): 0x12/13**

This read-only command pair returns the compensated capacity of the battery when fully charged. Units are mAh. *FullChargeCapacity( )* is updated at regular intervals, as specified by the IT algorithm.

**AverageCurrent( ): 0x14/0x15**

This read-only command pair returns a signed integer value that is the average current flow through the sense resistor. It is updated every 1 second. Units are mA.

**TimeToEmpty( ): 0x16/0x17**

This read-only function returns an unsigned integer value of the predicted remaining battery life at the present rate of discharge, in minutes. A value of 65,535 indicates battery is not being discharged.

**TimeToFull( ): 0x18/0x19**

This read-only function returns an unsigned integer value of predicted remaining time until the battery reaches full charge, in minutes, based upon *AverageCurrent( )*. The computation accounts for the taper current time extension from the linear TTF computation based on a fixed *AverageCurrent( )* rate of charge accumulation. A value of 65,535 indicates the battery is not being charged.

**StandbyCurrent( ): 0x1a/0x1b**

This read-only function returns a signed integer value of the measured standby current through the sense resistor. The *StandbyCurrent( )* is an adaptive measurement. Initially it reports the standby current programmed in **Initial Standby**, and after spending some time in standby, reports the measured standby current.

The register value is updated every 1 second when the measured current is above the **Deadband Current** and is less than or equal to 2 x **Initial Standby Current**. The first and last values that meet this criteria are not averaged in, since they may not be stable values. To approximate a 1 minute time constant, each new *StandbyCurrent( )* value is computed by taking approximate 93% weight of the last standby current and approximate 7% of the current measured average current.

**StandbyTimeToEmpty( ): 0x1c/0x1d**

This read-only function returns an unsigned integer value of the predicted remaining battery life at the standby rate of discharge, in minutes. The computation uses *Nominal Available Capacity (NAC)*, the uncompensated remaining capacity, for this computation. A value of 65,535 indicates battery is not being discharged.

**MaxLoadCurrent( ): 0x1e/0x1f**

This read-only function returns a signed integer value, in units of mA, of the maximum load conditions. The *MaxLoadCurrent( )* is an adaptive measurement which is initially reported as the maximum load current programmed in **Initial Max Load Current**. If the measured current is ever greater than **Initial Max Load Current**, then *MaxLoadCurrent( )* updates to the new current. *MaxLoadCurrent( )* is reduced to the average of the previous value and **Initial Max Load Current** whenever the battery is charged to full after a previous discharge to an SOC less than 50%. This prevents the reported value from maintaining an unusually high value.

***MaxLoadTimeToEmpty( ): 0x20/0x21***

This read-only function returns an unsigned integer value of the predicted remaining battery life at the maximum load current discharge rate, in minutes. A value of 65,535 indicates that the battery is not being discharged.

***AvailableEnergy( ): 0x22/0x23***

This read-only function returns an unsigned integer value of the predicted charge or energy remaining in the battery. The value is reported in units of mWh.

***AveragePower( ): 0x24/0x25***

This read-word function returns an unsigned integer value of the average power of the current discharge. A value of 0 indicates that the battery is not being discharged. The value is reported in units of mW.

***TimeToEmptyAtConstantPower( ): 0x26/0x27***

This read-only function returns an unsigned integer value of the predicted remaining operating time if the battery is discharged at the *AveragePower( )* value in minutes. A value of 65,535 indicates *AveragePower( )* = 0. The fuel gauge automatically updates *TimeToEmptyatContantPower( )* based on the *AveragePower( )* value every 1s.

***CycleCount( ): 0x2a/0x2b***

This read-only function returns an unsigned integer value of the number of cycles the battery has experienced with a range of 0 to 65,535. One cycle occurs when accumulated discharge  $\geq$  **CC Threshold**.

***StateOfCharge( ): 0x2c/0x2d***

This read-only function returns an unsigned integer value of the predicted remaining battery capacity expressed as a percentage of *FullChargeCapacity( )*, with a range of 0 to 100%.

## EXTENDED DATA COMMANDS

Extended commands offer additional functionality beyond the standard set of commands. They are used in the same manner; however unlike standard commands, extended commands are not limited to 2-byte words. The number of commands bytes for a given extended command ranges in size from single to multiple bytes, as specified in [Table 5](#). For details on the SEALED and UNSEALED states, see Section *Access Modes*.

**Table 5. Extended Commands**

NAME		COMMAND CODE	UNITS	SEALED ACCESS <sup>(1)</sup> <sup>(2)</sup>	UNSEALED ACCESS <sup>(1)</sup> <sup>(2)</sup>
Reserved	RSVD	0x34...0x3b	N/A	R	R
<i>DesignCapacity</i> ( )	DCAP	0x3c / 0x3d	mAh	R	R
<i>DataFlashClass</i> ( ) <sup>(2)</sup>	DFCLS	0x3e	N/A	N/A	R/W
<i>DataFlashBlock</i> ( ) <sup>(2)</sup>	DFBLK	0x3f	N/A	R/W	R/W
<i>BlockData</i> ( ) / <i>Authenticate</i> ( ) <sup>(3)</sup>	A/DF	0x40...0x53	N/A	R/W	R/W
<i>BlockData</i> ( ) / <i>AuthenticateChecksum</i> ( ) <sup>(3)</sup>	ACKS/DFD	0x54	N/A	R/W	R/W
<i>BlockData</i> ( )	DFD	0x55...0x5f	N/A	R	R/W
<i>BlockDataChecksum</i> ( )	DFDCKS	0x60	N/A	R/W	R/W
<i>BlockDataControl</i> ( )	DFDCNTL	0x61	N/A	N/A	R/W
<i>DeviceNameLength</i> ( )	DNAMELEN	0x62	N/A	R	R
<i>DeviceName</i> ( )	DNAME	0x63...0x69	N/A	R	R
Reserved	RSVD	0x6a...0x7f	N/A	R	R

(1) SEALED and UNSEALED states are entered via commands to **Control**( ) 0x00/0x01

(2) In sealed mode, data flash CANNOT be accessed through commands 0x3e and 0x3f.

(3) The *BlockData*( ) command area shares functionality for accessing general data flash and for using Authentication. See section on Authentication for more details.

### ***DesignCapacity*( ): 0x3c/0x3d**

SEALED and UNSEALED Access: This command returns the value is stored in **Design Capacity** and is expressed in mAh. This is intended to be the theoretical or nominal capacity of a new pack, but has no bearing on the operation of the fuel gauge functionality.

### ***DataFlashClass*( ): 0x3e**

UNSEALED Access: This command sets the data flash class to be accessed. The class to be accessed should be entered in hexadecimal.

SEALED Access: This command is not available in SEALED mode.

### ***DataFlashBlock*( ): 0x3f**

UNSEALED Access: This command sets the data flash block to be accessed. When 0x00 is written to *BlockDataControl*( ), *DataFlashBlock*( ) holds the block number of the data flash to be read or written. Example: writing a 0x00 to *DataFlashBlock*( ) specifies access to the first 32 byte block and a 0x01 specifies access to the second 32 byte block, and so on.

SEALED Access: This command directs which data flash block will be accessed by the *BlockData*( ) command. Writing a 0x00 to *DataFlashBlock*( ) specifies the *BlockData*( ) command will transfer authentication data. Issuing a 0x01, 0x02 or 0x03 instructs the *BlockData*( ) command to transfer **Manufacturer Info Block A, B, or C**, respectively.

### ***BlockData*( ): 0x40...0x5f**

This command range is used to transfer data for data flash class access. This command range is the 32-byte data block used to access Manufacturer Info Block A, B, or C. Manufacturer Info Block A is read only for the sealed access. UNSEALED access is read/write.

***BlockDataChecksum( )*: 0x60**

The host system should write this value to inform the device that new data is ready for programming into the specified data flash class and block.”

UNSEALED Access: This byte contains the checksum on the 32 bytes of block data read or written to data flash. The least-significant byte of the sum of the data bytes written must be complemented ( [255 – x] , for x the least-significant byte) before being written to 0x60.

SEALED Access: This byte contains the checksum for the 32 bytes of block data written to **Manufacturer Info Block A, B, or C**. The least-significant byte of the sum of the data bytes written must be complemented ( [255 – x] , for x the least-significant byte) before being written to 0x60.

***BlockDataControl( )*: 0x61**

UNSEALED Access: This command is used to control data flash access mode. Writing 0x00 to this command enables *BlockData( )* to access general data flash. Writing a 0x01 to this command enables SEALED mode operation of *DataFlashBlock( )*.

SEALED Access: This command is not available in SEALED mode.

***DeviceNameLength( )*: 0x62**

UNSEALED and SEALED Access: This byte contains the length of the **Device Name**.

***DeviceName( )*: 0x63...0x69**

UNSEALED and SEALED Access: This block contains the device name that is programmed in **Device Name**.

***Reserved – 0x6a – 0x7f***

## DATA FLASH INTERFACE

### Accessing the Data Flash

The bq27541 data flash is a non-volatile memory that contains bq27541 initialization, default, cell status, calibration, configuration, and user information. The data flash can be accessed in several different ways, depending on what mode the bq27541 is operating in and what data is being accessed.

Commonly accessed data flash memory locations, frequently read by a system, are conveniently accessed through specific instructions, already described in Section *Data Commands*. These commands are available when the bq27541 is either in UNSEALED or SEALED modes.

Most data flash locations, however, are only accessible in UNSEALED mode by use of the bq27541 evaluation software or by data flash block transfers. These locations should be optimized and/or fixed during the development and manufacture processes. They become part of a golden image file and can then be written to multiple battery packs. Once established, the values generally remain unchanged during end-equipment operation.

To access data flash locations individually, the block containing the desired data flash location(s) must be transferred to the command register locations, where they can be read to the system or changed directly. This is accomplished by sending the set-up command *BlockDataControl( )* (0x61) with data 0x00. Up to 32 bytes of data can be read directly from the *BlockData( )* (0x40...0x5f), externally altered, then rewritten to the *BlockData( )* command space. Alternatively, specific locations can be read, altered, and rewritten if their corresponding offsets are used to index into the *BlockData( )* command space. Finally, the data residing in the command space is transferred to data flash, once the correct checksum for the whole block is written to *BlockDataChecksum( )* (0x60).

Occasionally, a data flash CLASS will be larger than the 32-byte block size. In this case, the *DataFlashBlock( )* command is used to designate which 32-byte block the desired locations reside in. The correct command address is then given by 0x40 + offset *modulo* 32. For example, to access **Terminate Voltage** in the *Gas Gauging* class, *DataFlashClass( )* is issued 80 (0x50) to set the class. Because the offset is 48, it must reside in the second 32-byte block. Hence, *DataFlashBlock( )* is issued 0x01 to set the block offset, and the offset used to index into the *BlockData( )* memory area is 0x40 + 48 *modulo* 32 = 0x40 + 16 = 0x40 + 0x10 = 0x50.

Reading and writing subclass data are block operations up to 32 bytes in length. If during a write the data length exceeds the maximum block size, then the data is ignored.

None of the data written to memory are bounded by the bq27541 — the values are not rejected by the fuel gauge. Writing an incorrect value may result in hardware failure due to firmware program interpretation of the invalid data. The written data is persistent, so a power-on reset does resolve the fault.

## MANUFACTURER INFORMATION BLOCKS

The bq27541 contains 96 bytes of user programmable data flash storage: *Manufacturer Info Block A*, ***Manufacturer Info Block B***, *Manufacturer Info Block C*. The method for accessing these memory locations is slightly different, depending on whether the device is in UNSEALED or SEALED modes.

When in UNSEALED mode and when 0x00 has been written to *BlockDataControl*( ), accessing the Manufacturer Info Blocks is identical to accessing general data flash locations. First, a *DataFlashClass*( ) command is used to set the subclass, then a *DataFlashBlock*( ) command sets the offset for the first data flash address within the subclass. The *BlockData*( ) command codes contain the referenced data flash data. When writing the data flash, a checksum is expected to be received by *BlockDataChecksum*( ). Only when the checksum is received and verified is the data actually written to data flash.

As an example, the data flash location for ***Manufacturer Info Block B*** is defined as having a Subclass = 58 and an Offset = 32 through 63 (32 byte block). The specification of Class = System Data is not needed to address ***Manufacturer Info Block B***, but is used instead for grouping purposes when viewing data flash info in the bq27541 evaluation software.

When in SEALED mode or when 0x01 *BlockDataControl*( ) does not contain 0x00, data flash is no longer available in the manner used in UNSEALED mode. Rather than issuing subclass information, a designated Manufacturer Information Block is selected with the *DataFlashBlock*( ) command. Issuing a 0x01, 0x02, or 0x03 with this command causes the corresponding information block (A, B, or C, respectively) to be transferred to the command space 0x40...0x5f for editing or reading by the system. Upon successful writing of checksum information to *BlockDataChecksum*( ), the modified block is returned to data flash. **Note: *Manufacturer Info Block A*** is read-only when in SEALED mode.

## ACCESS MODES

The bq27541 provides three security modes (FULL ACCESS, UNSEALED, and SEALED) that control data flash access permissions according to [Table 6](#). *Data Flash* refers to those data flash locations, specified in [Table 7](#), that are accessible to the user. *Manufacture Information* refers to the three 32-byte blocks.

**Table 6. Data Flash Access**

Security Mode	Data Flash	Manufacturer Information
FULL ACCESS	R/W	R/W
UNSEALED	R/W	R/W
SEALED	None	R (A); R/W (B,C)

Although FULL ACCESS and UNSEALED modes appear identical, only FULL ACCESS mode allows the bq27541 to write access-mode transition keys.

## SEALING/UNSEALING DATA FLASH

The bq27541 implements a key-access scheme to transition between SEALED, UNSEALED, and FULL-ACCESS modes. Each transition requires that a unique set of two keys be sent to the bq27541 via the *Control*( ) control command. The keys must be sent consecutively, with no other data being written to the *Control*( ) register in between. Note that to avoid conflict, the keys must be different from the codes presented in the *CNTL DATA* column of [Table 2](#) subcommands.

When in SEALED mode the [SS] bit of CONTROL\_STATUS is set, but when the UNSEAL keys are correctly received by the bq27541, the [SS] bit is cleared. When the full-access keys are correctly received then the CONTROL\_STATUS [FAS] bit is cleared.

Both **Unseal Key** and **Full-Access Key** have two words and are stored in data flash. The first word is Key 0 and the second word is Key 1. The order of the keys sent to bq27541 are Key 1 followed by Key 0. The order of the bytes for each key entered through the *Control( )* command is the reverse of what is read from the part. For an example, if the Unseal Key is 0x56781234, key 1 is 0x1234 and key 0 is 0x5678. Then *Control( )* should supply 0x3412 and 0x7856 to unseal the part. The **Unseal key** and the FULL-ACCESS key cap only be updated when in FULL-ACCESS mode.

## DATA FLASH SUMMARY

Table 7 summarizes the data flash locations available to the user, including their default, minimum, and maximum values.

**Table 7. Data Flash Summary**

Class	Subclass ID	Subclass	Offset	Name	Data Type	Min Value	Max Value	Default Value	Units
Configuration	2	Safety	0	OT Chg	I2	0	1200	550	0.1°C
Configuration	2	Safety	2	OT Chg Time	U1	0	60	2	s
Configuration	2	Safety	3	OT Chg Recovery	I2	0	1200	500	0.1°C
Configuration	2	Safety	5	OT Dsg	I2	0	1200	600	0.1°C
Configuration	2	Safety	7	OT Dsg Time	U1	0	60	2	s
Configuration	2	Safety	8	OT Dsg Recovery	I2	0	1200	550	0.1°C
Configuration	32	Charge Inhibit Config	0	Charge Inhibit Temp Low	I2	-400	1200	0	0.1°C
Configuration	32	Charge Inhibit Config	2	Charge Inhibit Temp High	I2	-400	1200	450	0.1°C
Configuration	32	Charge Inhibit Config	4	Temp Hys	I2	0	100	50	0.1°C
Configuration	34	Charge	2	Charging Voltage	I2	0	20,000	4200	mV
Configuration	34	Charge	4	Delta Temperature	I2	0	500	50	0.1°C
Configuration	34	Charge	6	Suspend Temperature Low	I2	-400	1200	-50	0.1°C
Configuration	34	Charge	8	Suspend Temperature High	I2	-400	1200	550	0.1°C
Configuration	36	Charge Termination	2	Taper Current	I2	0	1000	100	mA
Configuration	36	Charge Termination	4	Minimum Taper Charge	I2	0	1000	25	0.01mAh
Configuration	36	Charge Termination	6	Taper Voltage	I2	0	1000	100	mV
Configuration	36	Charge Termination	8	Current Taper Window	U1	0	60	40	s
Configuration	36	Charge Termination	9	Terminate Charge Alarm Set %	I1	-1	100	99	%
Configuration	36	Charge Termination	10	Terminate Charge Alarm Clear %	I1	-1	100	95	%
Configuration	36	Charge Termination	11	Full Charge Set %	I1	-1	100	100	%
Configuration	36	Charge Termination	12	Full Charge Clear %	I1	-1	100	98	%
Configuration	48	Data	0	Remaining Capacity Alarm	I2	0	70	100	mAh
Configuration	48	Data	8	Initial Standby Current	I1	-256	0	-10	mA
Configuration	48	Data	9	Initial Max Load Current	I2	-32,767	0	-500	mA
Configuration	48	Data	17	Cycle Count	U2	0	65535	0	Count
Configuration	48	Data	19	CC Threshold	I2	100	32,767	900	mAh
Configuration	48	Data	23	Design Capacity	I2	0	65,535	1000	mAh
Configuration	48	Data	39	Device Name	S8	x	x	bq27541	-
Configuration	49	Discharge	0	SOC1 Set Threshold	U1	0	255	150	mAh
Configuration	49	Discharge	1	SOC1 Clear	U1	0	255	175	mAh
Configuration	49	Discharge	2	SOCF Set Threshold	U1	0	255	75	mAh
Configuration	49	Discharge	3	SOCF Clear	U1	0	255	100	mAh
System Data	58	Manufacturer Info	0-31	Block A [0-31]	H1	0x00	0xff	0x00	-
System Data	58	Manufacturer Info	32-63	Block B [0-31]	H1	0x00	0xff	0x00	-
System Data	58	Manufacturer Info	64-95	Block C [0-31]	H1	0x00	0xff	0x00	-
Configuration	64	Registers	0	Pack Configuration	H2	0x0000	0xffff	0x0135	-
Configuration	68	Power	0	Flash Update OK Voltage	I2	0	4200	2800	mV
Configuration	68	Power	7	Sleep Current	I2	0	100	10	mA
Configuration	68	Power	16	Hibernate Current	U2	0	700	8	mA
Configuration	68	Power	18	Hibernate Voltage	U2	2400	3000	2550	mV
Configuration	68	Power	20	Full Sleep Wait Time	U1	0	255	0	s
Gas Gauging	80	IT Cfg	0	Load Select	U1	0	255	1	-
Gas Gauging	80	IT Cfg	1	Load Mode	U1	0	255	0	-
Gas Gauging	80	IT Cfg	48	Terminate Voltage	I2	2800	3700	3000	mV
Gas Gauging	80	IT Cfg	65	User Rate-mW	I2	0	14,000	0	mW
Gas Gauging	80	IT Cfg	67	Reserve Cap-mAh	I2	0	9000	0	mAh
Gas Gauging	80	IT Cfg	69	Reserve Cap-mWh	I2	0	14,000	0	mWh

**Table 7. Data Flash Summary (continued)**

Class	Subclass ID	Subclass	Offset	Name	Data Type	Min Value	Max Value	Default Value	Units
Gas Gauging	81	Current Thresholds	0	Dsg Current Threshold	I2	0	2000	60	mA
Gas Gauging	81	Current Thresholds	2	Chg Current Threshold	I2	0	2000	75	mA
Gas Gauging	81	Current Thresholds	4	Quit Current	I2	0	1000	40	mA
Gas Gauging	81	Current Thresholds	6	Dsg Relax Time	U2	0	8191	1800	s
Gas Gauging	81	Current Thresholds	8	Chg Relax Time	U1	0	255	60	s
Gas Gauging	81	Current Thresholds	9	Quit Relax Time	U1	0	63	1	s
Gas Gauging	82	State	0	Qmax Cell0	I2	0	32,767	1000	mAh
Gas Gauging	82	State	2	Qmax	I2	0	32,767	1500	mAh
Gas Gauging	82	State	4	Cycle Count	U2	0	65,535	0	–
Gas Gauging	82	State	6	Update Status	H1	0x00	0x03	0x00	–
Gas Gauging	82	State	9	Avg I Last Run	I2	-32,768	32,767	-299	mA
Gas Gauging	82	State	11	Avg P Last Run	I2	-32,768	32,767	-1131	mAh
Ra Tables	88	Pack Ra0	0-31	See <sup>(1)</sup>					
Ra Tables	89	Pack Ra0x	0-31						
Calibration	104	Data	0	CC Gain	F4 <sup>(2)</sup>	0.1	47	10 <sup>(3)</sup>	mΩ
Calibration	104	Data	4	CC Delta	F4 <sup>(2)</sup>	4.7	188	10 <sup>(3)</sup>	mΩ
Calibration	104	Data	8	CC Offset	I2	-2.4	24	-0.088 <sup>(3)</sup>	mV
Calibration	104	Data	10	Board Offset	I1	-128	127	0	mV
Calibration	104	Data	11	Int Temp Offset	I1	-128	127	0	0.1°C
Calibration	104	Data	12	Ext Temp Offset	I1	-128	127	0	0.1°C
Calibration	104	Data	13	Pack V Offset	I1	-128	127	0	mV
Calibration	107	Current	1	Deadband	U1	0	255	5	mA
Security	112	Codes	0	Unseal Key	H4	0x0000	0xffffffff	0x36720414	–
Security	112	Codes	4	Full-Access Key	H4	0x0000	0xffffffff	0xffffffff	–
Security	112	Codes	8	Authentication Key 3	H4	0x0000	0xffffffff	0x01234567	–
Security	112	Codes	12	Authentication Key 2	H4	0x0000	0xffffffff	89ABCDEF	–
Security	112	Codes	16	Authentication Key 1	H4	0x0000	0xffffffff	FEDCBA98	–
Security	112	Codes	20	Authentication Key 0	H4	0x0000	0xffffffff	76543210	–

- (1) Encoded battery profile information created by bqEasy software  
 (2) Not IEEE floating point  
 (3) Display as the value EVSW displayed. Data Flash value is different.

## FUNCTIONAL DESCRIPTION

### FUEL GAUGING

The bq27541 measures the cell voltage, temperature, and current to determine battery SOC. The bq27541 monitors charge and discharge activity by sensing the voltage across a small-value resistor (5 mΩ to 20 mΩ typ.) between the SRP and SRN pins and in series with the cell. By integrating charge passing through the battery, the battery's SOC is adjusted during battery charge or discharge.

The total battery capacity is found by comparing states of charge before and after applying the load with the amount of charge passed. When an application load is applied, the impedance of the cell is measured by comparing the OCV obtained from a predefined function for present SOC with the measured voltage under load. Measurements of OCV and charge integration determine chemical state of charge and chemical capacity (Qmax). The initial Qmax values are taken from a cell manufacturers' data sheet multiplied by the number of parallel cells. It is also used for the value in **Design Capacity**. The bq27541 acquires and updates the battery-impedance profile during normal battery usage. It uses this profile, along with SOC and the Qmax value, to determine *FullChargeCapacity()* and *StateOfCharge()*, specifically for the present load and temperature. *FullChargeCapacity()* is reported as capacity available from a fully charged battery under the present load and temperature until *Voltage()* reaches the **Terminate Voltage**. *NominalAvailableCapacity()* and *FullAvailableCapacity()* are the uncompensated (no or light load) versions of *RemainingCapacity()* and *FullChargeCapacity()* respectively.

The bq27541 has two flags accessed by the *Flags()* function that warns when the battery's SOC has fallen to critical levels. When *RemainingCapacity()* falls below the first capacity threshold, specified in **SOC1 Set Threshold**, the *[SOC1]* (*State of Charge Initial*) flag is set. The flag is cleared once *RemainingCapacity()* rises above **SOC1 Set Threshold**. All units are in mAh.

When *RemainingCapacity()* falls below the second capacity threshold, **SOCF Set Threshold**, the *[SOCF]* (*State of Charge Final*) flag is set, serving as a final discharge warning. If **SOCF Set Threshold** = -1, the flag is inoperative during discharge. Similarly, when *RemainingCapacity()* rises above **SOCF Clear Threshold** and the *[SOCF]* flag has already been set, the *[SOCF]* flag is cleared. All units are in mAh.

### IMPEDANCE TRACK™ VARIABLES

The bq27541 has several data flash variables that permit the user to customize the Impedance Track™ algorithm for optimized performance. These variables are dependent upon the power characteristics of the application as well as the cell itself.

#### Load Mode

*Load Mode* is used to select either the constant-current or constant-power model for the Impedance Track™ algorithm as used in **Load Select** (see **Load Select**). When **Load Mode** is 0, the *Constant Current Model* is used (default). When 1, the *Constant Power Model* is used. The *[LDMD]* bit of CONTROL\_STATUS reflects the status of **Load Mode**.

#### Load Select

**Load Select** defines the type of power or current model to be used to compute load-compensated capacity in the Impedance Track™ algorithm. If **Load Mode** = 0 (*Constant Current*), then the options presented in [Table 8](#) are available.

**Table 8. Constant-Current Model Used when Load Mode = 0**

LoadSelect Value	Current Model Used
0	Average discharge current from previous cycle: There is an internal register that records the average discharge current through each entire discharge cycle. The previous average is stored in this register.
1(default)	Present average discharge current: This is the average discharge current from the beginning of this discharge cycle until present time.
2	Average current: based off the <b>AverageCurrent()</b>
3	Current: based off of a low-pass-filtered version of <b>AverageCurrent()</b> ( $\tau = 14s$ )
4	Design capacity / 5: C Rate based off of Design Capacity /5 or a C / 5 rate in mA.
5	AtRate (mA): Use whatever current is in <b>AtRate()</b>
6	User_Rate-mA: Use the value in <b>User_Rate()</b> . This gives a completely user-configurable method.

If **Load Mode** = 1 (Constant Power) then the following options are available:

**Table 9. Constant-Power Model Used When Load Mode = 1**

LoadSelect Value	Power Model Used
0 (default)	Average discharge power from previous cycle: There is an internal register that records the average discharge power through each entire discharge cycle. The previous average is stored in this register.
1	Present average discharge power: This is the average discharge power from the beginning of this discharge cycle until present time.
2	Average current x voltage: based off the <b>AverageCurrent( )</b> and <b>Voltage( )</b> .
3	Current x voltage: based off of a low-pass-filtered version of <b>AverageCurrent( )</b> ( $\tau = 14s$ ) and <b>Voltage( )</b>
4	Design energy / 5: C Rate based off of Design Energy /5 or a C / 5 rate in mA .
5	AtRate (10 mW): Use whatever value is in <b>AtRate( )</b> .
6	User_Rate-10mW: Use the value in. <b>User_Rate( )</b> mW. This gives a completely user- configurable method.

### Reserve Cap-mAh

**Reserve Cap-mAh** determines how much actual remaining capacity exists after reaching 0 **RemainingCapacity( )**, before **Terminate Voltage** is reached. A no-load rate of compensation is applied to this reserve.

### Reserve Cap-mWh

**Reserve Cap-mWh** determines how much actual remaining capacity exists after reaching 0 **AvailableEnergy( )**, before **Terminate Voltage** is reached. A no-load rate of compensation is applied to this reserve capacity.

### Dsg Current Threshold

This register is used as a threshold by many functions in the bq27541 to determine if actual discharge current is flowing into or out of the cell. The default for this register should be sufficient for most applications. This threshold should be set low enough to be below any normal application load current but high enough to prevent noise or drift from affecting the measurement.

### Chg Current Threshold

This register is used as a threshold by many functions in the bq27541 to determine if actual charge current is flowing into or out of the cell. The default for this register should be sufficient for most applications. This threshold should be set low enough to be below any normal charge current but high enough to prevent noise or drift from affecting the measurement.

### Quit Current, Dsg Relax Time, Chg Relax Time, and Quit Relax Time

The **Quit Current** is used as part of the Impedance Track™ algorithm to determine when the bq27541 enters relaxation mode from a current flowing mode in either the charge direction or the discharge direction. The value of Quit Current is set to a default value that should be above the standby current of the system.

Either of the following criteria must be met to enter relaxation mode:

1.  $|AverageCurrent( )| < |Quit Current|$  for **Dsg Relax Time**.
2.  $|AverageCurrent( )| < |Quit Current|$  for **Chg Relax Time**.

After about 30 minutes in relaxation mode, the bq27541 attempts to take accurate OCV readings. An additional requirement of  $dV/dt < 4 \mu V/sec$  is required for the bq27541 to perform Qmax updates. These updates are used in the Impedance Track™ algorithms. It is critical that the battery voltage be relaxed during OCV readings to and that the current is not be higher than C/20 when attempting to go into relaxation mode.

**Quit Relax Time** specifies the minimum time required for **AverageCurrent( )** to remain above the **QuitCurrent** threshold before exiting relaxation mode.

## Qmax

**Qmax** contains the maximum chemical capacity of the active cell profiles, and is determined by comparing states of charge before and after applying the load with the amount of charge passed. They also correspond to capacity at low rate of discharge, such as C/20 rate. For high accuracy, this value is periodically updated by the bq27541 during operation. Based on the battery cell capacity information, the initial value of chemical capacity should be entered in **Qmax** field. The Impedance Track™ algorithm will update this value and maintain it in the **Pack** profile.

## Update Status

Bit 0 (0x01) of the **Update Status** register indicates that the bq27541 has learned new Qmax parameters and is accurate. The remaining bits are reserved. Bit 0 is a status bit set by the bq27541. Bit 0 should never be modified except when creating a golden image file as explained in the application note *Preparing Optimized Default Flash Constants for specific Battery Types* (SLUA334.pdf). Bit 0 is updated as needed by the bq27541.

## Avg I Last Run

The bq27500 logs the current averaged from the beginning to the end of each discharge cycle. It stores this average current from the previous discharge cycle in this register. This register should never need to be modified. It is only updated by the bq27541 when required.

## Avg P Last Run

The bq27541 logs the power averaged from the beginning to the end of each discharge cycle. It stores this average power from the previous discharge cycle in this register. To get a correct average power reading the bq27541 continuously multiplies instantaneous current times *Voltage( )* to get power. It then logs this data to derive the average power. This register should never need to be modified. It is only updated by the bq27541 when required.

## Delta Voltage

The bq27541 stores the maximum difference of *Voltage( )* during short load spikes and normal load, so the Impedance Track™ algorithm can calculate remaining capacity for pulsed loads. It is not recommended to change this value.

## Default Ra and Ra Tables

These tables contain encoded data and, with the exception of the **Default Ra Tables**, are automatically updated during device operation. No user changes should be made except for reading/writing the values from a prelearned pack (part of the process for creating golden image files).

## DETAILED PIN DESCRIPTIONS

### System Shutdown Enable (SE Pin)

If the CONTROL\_STATUS[SHUTDOWN] has been set, bq27541 will immediately pull the SE pin low at POR. The fuel gauge can be made to power-off through an external circuit when it releases the SE pin to high impedance. With an external circuit, this feature is useful to shutdown the fuel gauge in a deeply discharged battery to protect the battery. The SE pin is released to open drain state when the gauge enters HIBERNATE mode with the CONTROL\_STATUS[HIBERNATE] and [SHUTDOWN] bits set.

### The Pack Configuration Register

Some bq27541 pins are configured via the **Pack Configuration** data flash register, as indicated in [Table 10](#). This register is programmed/read via the methods described in Section 1.2.1: Accessing the Data Flash. The register is located at subclass = 64, offset = 0.

**Table 10. Pack Configuration Bit Definition**

	bit7	bit6	bit5	bit4	bit3	bit2	bit1	bit0
High Byte	RESCAP	–	–	–	–	IWAKE	RSNS1	RSNS0
Low Byte	–	–	SLEEP	RMFCC	SE_PU	SE_POL	–	TEMPS

RESCAP = No-load rate of compensation is applied to the reserve capacity calculation. True when set. Default is 0.

IWAKE/RSNS1/RSNS0 = These bits configure the current wake function (see Table 11). Default is 0/0/1.

SLEEP = The fuel gauge can enter sleep, if operating conditions allow. True when set. Default is 1.

RMFCC = RM is updated with the value from FCC, on valid charge termination. True when set. Default is 1.

SE\_PU = Pull-up enable for SE pin. True when set (push-pull). Default is 0.

SE\_POL = Polarity bit for SE pin. SE is active low when clear. Default is 1 (makes SE high when gauge is ready for shutdown).

TEMPS = Selects external thermistor for Temperature( ) measurements. True when set. Default is 1.

## TEMPERATURE MEASUREMENT AND THE TS INPUT

The bq27541 measures battery temperature via the TS input, in order to supply battery temperature status information to the fuel gauging algorithm and charger-control sections of the gauge. Alternatively, the gauge can also measure internal temperature via its on-chip temperature sensor, but only if the **[TEMPS]** bit of **Pack Configuration** register is cleared.

Regardless of which sensor is used for measurement, a system processor can request the current battery temperature by calling the *Temperature( )* function (see Section *Standard Data Commands*, for specific information).

The thermistor circuit requires the use of an external 10Kohm thermistor with negative temperature coefficients, such as Semetic 103AT-type thermistor that connects between the Vcc and TS pins. Additional circuit information for connecting this thermistor to the bq27541 is shown in **Section 4, Reference Schematic**.

## OVERTEMPERATURE INDICATION

### 2.3.1 Overtemperature: Charge

If during charging, *Temperature( )* reaches the threshold of **OT Chg** for a period of **OT Chg Time** and *AverageCurrent( )* > **Chg Current Threshold**, then the [OTC] bit of *Flags( )* is set. When *Temperature( )* falls to **OT Chg Recovery**, the [OTC] of *Flags( )* is reset.

If **OT Chg Time** = 0, the feature is completely disabled.

### Overtemperature: Discharge

If during discharging, *Temperature( )* reaches the threshold of **OT Dsg** for a period of **OT Dsg Time**, and *AverageCurrent( )* ≤ **-Dsg Current Threshold**, then the [OTD] bit of *Flags( )* is set. When *Temperature( )* falls to **OT Dsg Recovery**, the [OTD] bit of *Flags( )* is reset.

If **OT Dsg Time** = 0, the feature is completely disabled.

## CHARGE-TERMINATION-/INHIBIT INDICATORS

### Detection Charge Termination

For proper bq27541 operation, the cell charging voltage must be specified by the user. The default value for this variable is in the data flash **Charging Voltage**.

The bq27541 detects charge termination when (1) during 2 consecutive periods of Current Taper **Window**, the *AverageCurrent( )* is < **Taper Current**, (2) during the same periods, the accumulated change in capacity > 0.25mAh / **Current Taper Window**, and (3) *Voltage( )* > **Charging Voltage – Taper Voltage**. When this occurs,

the *[CHG]* bit of *Flags( )* is cleared. Also, if the *[RMFCC]* bit of **Pack Configuration** is set, and *RemainingCapacity( )* is set equal to *FullChargeCapacity( )*. When *TCA\_Set* is set to -1, it disables the use of the charger alarm threshold. In that case, *TerminateCharge* is set when the taper condition is detected. When *FC\_Set* is set to -1, it disables the use of the full charge detection threshold. In that case, *FullCharge* is not set until the taper condition is met.

### Charge Inhibit

The bq27541 can indicate when battery temperature has fallen below or risen above predefined thresholds (**Charge Inhibit Temp Low** and **Charge Inhibit Temp High**, respectively). In this mode, the *[CHG\_INH]* of *Flags( )* is made high to indicate this condition, and is returned to its low state, once battery temperature returns to the range *[Charge Inhibit Temp Low + Temp Hys, Charge Inhibit Temp High – Temp Hys]*.

## POWER MODES

The bq27500 has three power modes: NORMAL, SLEEP, and HIBERNATE. In NORMAL mode, the bq27541 is fully powered and can execute any allowable task. In SLEEP mode the fuel gauge exists in a reduced-power state, periodically taking measurements and performing calculations. Finally, in HIBERNATE mode, the fuel gauge is in a low power state, but can be awoken by communication or certain I/O activity.

The relationship between these modes is shown in [Figure 3](#).

### NORMAL Mode

The fuel gauge is in NORMAL Mode when not in any other power mode. During this mode, *AverageCurrent( )*, *Voltage( )* and *Temperature( )* measurements are taken, and the interface data set is updated. Decisions to change states are also made. This mode is exited by activating a different power mode.

Because the gauge consumes the most power in NORMAL mode, the Impedance Track™ algorithm minimizes the time the fuel gauge remains in this mode.

### SLEEP Mode

SLEEP mode is entered automatically if the feature is enabled (**Pack Configuration [SLEEP]** = 1) and *AverageCurrent( )* is below the programmable level **Sleep Current**. Once entry into SLEEP mode has been qualified, but prior to entering it, the bq27541 performs an ADC autocalibration to minimize offset.

While in SLEEP mode, the fuel gauge can suspend serial communications as much as 4ms by holding the comm line(s) low. This delay is necessary to correctly process host communication, since the fuel gauge processor is mostly halted in SLEEP mode.

During the SLEEP mode, bq27541 periodically takes data measurements and updates its data set. However, a majority of its time is spent in an idle condition.

The bq27541 exits SLEEP if any entry condition is broken, specifically when (1) *AverageCurrent( )* rises above **Sleep Current**, or (2) a current in excess of  $I_{WAKE}$  through  $R_{SENSE}$  is detected.

### FULLSLEEP Mode

FULLSLEEP mode is entered automatically if the feature is enabled by setting the **Pack Configuration [FULLSLEEP]** bit in the Control Status register when the bq27541 is in SLEEP mode. The gauge exits the FULLSLEEP mode when there is any communication activity. Therefore, the execution of SET\_FULLSLEEP sets **[FULLSLEEP]** bit, but EVSW might still display the bit clear. The FULLSLEEP mode can be verified by measuring the current consumption of the gauge. In this mode, the high frequency oscillator is turned off. The power consumption is further reduced in this mode compared to the SLEEP mode.

FULLSLEEP mode can also be entered by set the **Full Sleep Wait Time** to be a number larger than 0. The FULLSLEEP will be entered when the timer counts down to 0. This feature is disabled when the data flash is set as 0.

During FULLSLEEP mode, the bq27541 periodically takes data measurements and updates its data set. However, a majority of its time is spent in an idle condition.

The bq27541 exits SLEEP if any entry condition is broken, specifically when (1) *AverageCurrent( )* rises above **Sleep Current**, or (2) a current in excess of  $I_{WAKE}$  through  $R_{SENSE}$  is detected.

While in FULLSLEEP mode, the fuel gauge can suspend serial communications as much as 4ms by holding the comm line(s) low. This delay is necessary correctly process host communication, since the fuel gauge processor is mostly halted in SLEEP mode.

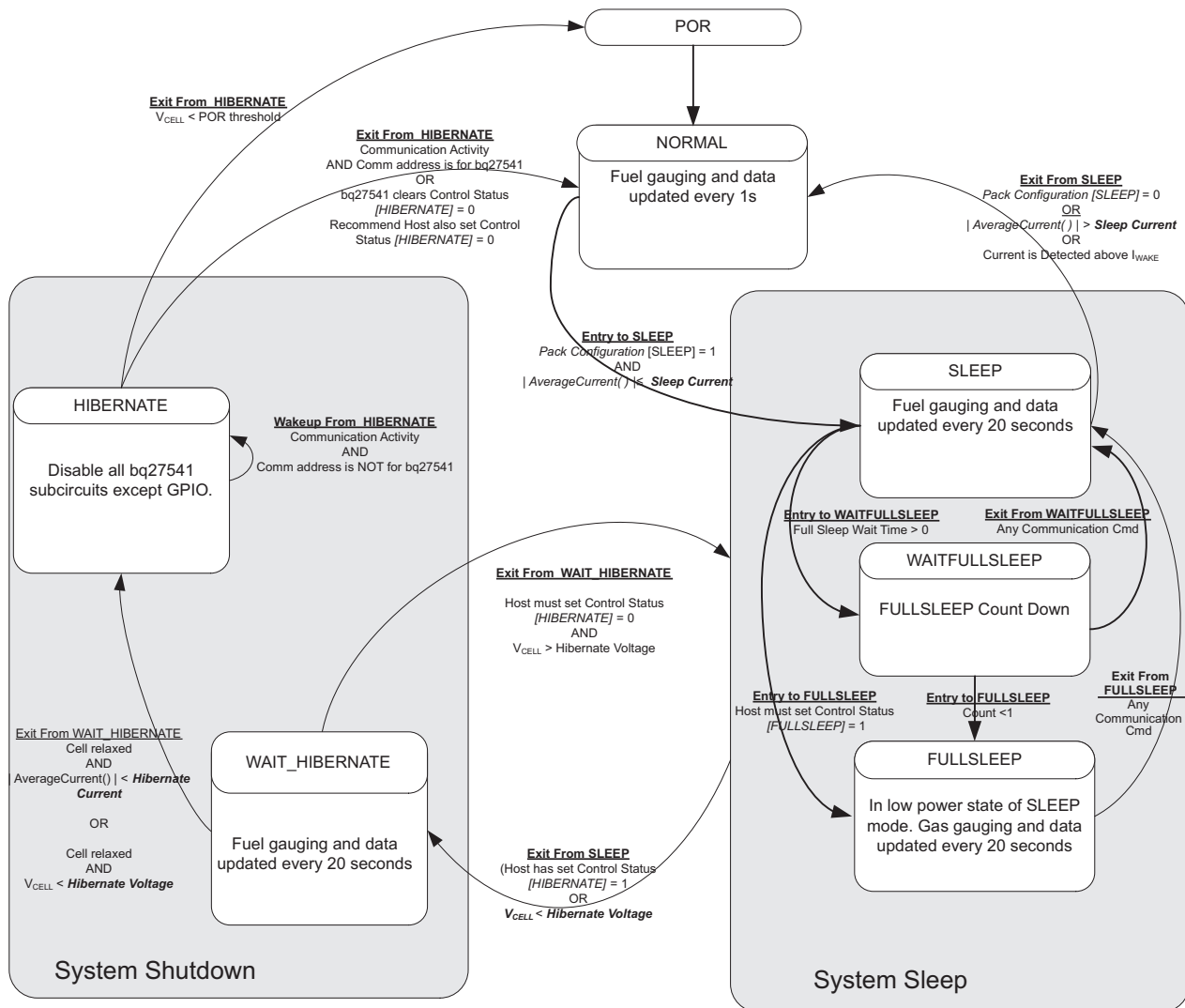

Figure 3. Power Mode Diagram

### HIBERNATE Mode

HIBERNATE mode should be used when the host system needs to enter a low-power state, and minimal gauge power consumption is required. This mode is ideal when the host is set to its own HIBERNATE, SHUTDOWN, or OFF modes. The fuel gauge can enter HIBERNATE due to either low cell voltage or low load current.

– HIBERNATE due to the cell voltage. When the cell voltage drops below the Hibernate Voltage and a valid OCV measurement has been taken, the fuel gauge enters HIBERNATE mode. The [HIBERNATE] bit of the CONTROL register has no impact for the fuel gauge to enter the HIBERNATE mode. If the [SHUTDOWN] bit of CONTROL\_STATUS is also set, the SE pin will be released, thereby allowing an optional external circuit to remove power from the gauge LDO.

– HIBERNATE due to the load current. If the fuel gauge enters the HIBERNATE mode due to the load current, the [HIBERNATE] bit of the CONTROL\_STATUS register must be set. The gauge waits to enter HIBERNATE mode until it has taken a valid OCV measurement and the magnitude of the average cell current has fallen below Hibernate Current.

The gauge will remain in HIBERNATE mode until communication activity appears on the communication lines. Upon exiting HIBERNATE mode, the *[HIBERNATE]* bit of CONTROL\_STATUS is cleared.

Because the fuel gauge is dormant in HIBERNATE mode, the battery should not be charged or discharged in this mode, because any changes in battery charge status will not be measured. If necessary, the host equipment can draw a small current (generally infrequent and less than 1mA, for purposes of low-level monitoring and updating); however, the corresponding charge drawn from the battery will not be logged by the gauge. Once the gauge exits to NORMAL mode, the IT algorithm will re-establish the correct battery capacity, regardless of the total charge drawn in HIBERNATE mode.

If a charger is attached, the host should immediately take the fuel gauge out of HIBERNATE mode before beginning to charge the battery. Charging the battery in HIBERNATE mode will result in a notable gauging error that will take several hours to correct.

## POWER CONTROL

### Reset Functions

When the bq27541 detects a software reset (*[RESET]* bit of *Control()* initiated), it determines the type of reset and increments the corresponding counter. This information is accessible by issuing the command *Control()* function with the RESET\_DATA subcommand.

As shown in [Figure 4](#) if a partial reset was detected, a RAM checksum is generated and compared against the previously stored checksum. If the checksum values do not match, the RAM is reinitialized (a *Full Reset*). The stored checksum is updated every time RAM is altered.

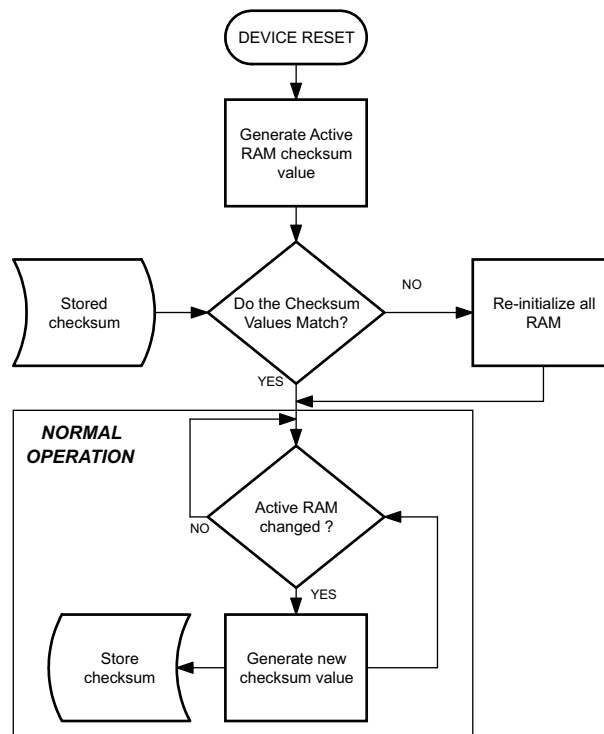

**Figure 4. Partial Reset Flow Diagram**

## Wake-Up Comparator

The wake up comparator is used to indicate a change in cell current while the bq27541 is in either SLEEP or HIBERNATE modes. **Pack Configuration** uses bits **[RSNS1-RSNS0]** to set the sense resistor selection. **Operation Configuration** also uses the **[IWAKE]** bit to select one of two possible voltage threshold ranges for the given sense resistor selection. An internal interrupt is generated when the threshold is breached in either charge or discharge directions. Setting both **[RSNS1]** and **[RSNS0]** to 0 disables this feature..

**Table 11. I<sub>WAKE</sub> Threshold Settings<sup>(1)</sup>**

RSNS1	RSNS0	IWAKE	Vth(SRP-SRN)
0	0	0	Disabled
0	0	1	Disabled
0	1	0	+1.25 mV or –1.25 mV
0	1	1	+2.5 mV or –2.5 mV
1	0	0	+2.5 mV or –2.5 mV
1	0	1	+5 mV or –5 mV
1	1	0	+5 mV or –5 mV
1	1	1	+10 mV or –10 mV

(1) The actual resistance value vs. the setting of the sense resistor is not important just the actual voltage threshold when calculating the configuration.

## Flash Updates

Data Flash can only be updated if  $Voltage( ) \geq \text{Flash Update OK Voltage}$ . Flash programming current can cause an increase in LDO dropout. The value of **Flash Update OK Voltage** should be selected such that the bq27541 Vcc voltage does not fall below its minimum of 2.4V during Flash write operations.

## AUTOCALIBRATION

The bq27541 provides an autocalibration feature that will measure the voltage offset error across SRP and SRN from time-to-time as operating conditions change. It subtracts the resulting offset error from normal sense resistor voltage,  $V_{SR}$ , for maximum measurement accuracy.

Autocalibration of the ADC begins on entry to SLEEP mode, except if  $Temperature( ) \leq 5^{\circ}\text{C}$  or  $Temperature( ) \geq 45^{\circ}\text{C}$ .

The fuel gauge also performs a single offset when (1) the condition of  $AverageCurrent( ) \leq 100\text{mA}$  and (2) {voltage change since last offset calibration  $\geq 256\text{mV}$ } or {temperature change since last offset calibration is greater than  $80^{\circ}\text{C}$  for  $\geq 60\text{s}$ }.

Capacity and current measurements will continue at the last measured rate during the offset calibration when these measurements cannot be performed. If the battery voltage drops more than 32mV during the offset calibration, the load current has likely increased considerably; hence, the offset calibration will be aborted.

## COMMUNICATIONS

### AUTHENTICATION

The bq27541 can act as a SHA-1/HMAC authentication slave by using its internal engine. Sending a 160-bit SHA-1 challenge message to the bq27541 will cause the gauge to return a 160-bit digest, based upon the challenge message and a hidden, 128-bit plain-text authentication key. If this digest matches an identical one generated by a host or dedicated authentication master, and when operating on the same challenge message and using the same plain text keys, the authentication process is successful.

### KEY PROGRAMMING (DATA FLASH KEY)

By default, the bq27541 contains a default plain-text authentication key of 0x0123456789ABCDEFDCBA9876543210. This default key is intended for development purposes. It should be changed to a secret key and the part immediately sealed, before putting a pack into operation. Once written, a new plain-text key cannot be read again from the fuel gauge while in SEALED mode.

Once the bq27541 is UNSEALED, the authentication key can be changed from its default value by writing to the *Authentication( )* Extended Data Command locations. A 0x00 is written to *BlockDataControl( )* to enable the authentication data commands. The bq27541 is now prepared to receive the 16-byte plain-text key, which must begin at command location 0x40 and ending at 0x4f. Once written, the key is accepted when a successful checksum for the key has been written to *AuthenticateChecksum( )*. The gauge can then be SEALED again.

### KEY PROGRAMMING (THE SECURE MEMORY KEY)

As the name suggests, the bq27541 secure-memory authentication key is stored in the secure memory of the bq27541. If a secure-memory key has been established, only this key can be used for authentication challenges (the programmable data flash key is not available). The selected key can only be established/programmed by special arrangements with TI, using the TI's *Secure B-to-B Protocol*. The secure-memory key can never be changed or read from the bq27541.

### EXECUTING AN AUTHENTICATION QUERY

To execute an authentication query in UNSEALED mode, a host must first write 0x01 to the *BlockDataControl( )* command, to enable the authentication data commands. If in SEALED mode, 0x00 must be written to *DataFlashBlock( )*, instead.

Next, the host writes a 20-byte authentication challenge to the *Authenticate( )* address locations (0x40 through 0x53). After a valid checksum for the challenge is written to *AuthenticateChecksum( )*, the bq27541 uses the challenge to perform its own the SHA-1/HMAC computation, in conjunction with its programmed keys. The resulting digest is written to *AuthenticateData( )*, overwriting the pre-existing challenge. The host may then read this response and compare it against the result created by its own parallel computation.

## HDQ SINGLE-PIN SERIAL INTERFACE

The HDQ interface is an asynchronous return-to-one protocol where a processor sends the command code to the bq27541. With HDQ, the least significant bit (LSB) of a data byte (command) or word (data) is transmitted first. Note that the DATA signal on pin 12 is open-drain and requires an external pull-up resistor. The 8-bit command code consists of two fields: the 7-bit HDQ command code (bits 0–6) and the 1-bit R/W field (MSB bit 7). The R/W field directs the bq27541 either to

- Store the next 8 or 16 bits of data to a specified register or
- Output 8 or 16 bits of data from the specified register

The HDQ peripheral can transmit and receive data as either an HDQ master or slave.

The return-to-one data bit frame of HDQ consists of three distinct sections. The first section is used to start the transmission by either the host or by the bq27541 taking the DATA pin to a logic-low state for a time  $t_{(STRH,B)}$ . The next section is for data transmission, where the data are valid for a time  $t_{(DSU)}$ , after the negative edge used to start communication. The data are held until a time  $t_{(DV)}$ , allowing the host or bq27541 time to sample the data bit. The final section is used to stop the transmission by returning the DATA pin to a logic-high state by at least a time  $t_{(SSU)}$ , after the negative edge used to start communication. The final logic-high state is held until the end of  $t_{(CYCH,B)}$ , allowing time to ensure the transmission was stopped correctly. The timing for data and break communication are given in the HDQ characteristics section.

HDQ serial communication is normally initiated by the host processor sending a break command to the bq27541. A break is detected when the DATA pin is driven to a logic-low state for a time  $t_{(B)}$  or greater. The DATA pin should then be returned to its normal ready high logic state for a time  $t_{(BR)}$ . The bq27541 is now ready to receive information from the host processor.

The bq27541 is shipped in the I2C mode. TI provides tools to enable the HDQ peripheral.

## I<sup>2</sup>C INTERFACE

The fuel gauge supports the standard I<sup>2</sup>C read, incremental read, one-byte write quick read, and functions. The 7-bit device address (ADDR) is the most significant 7 bits of the hex address and is fixed as 1010101. The 8-bit device address is therefore 0xaa or 0xab for write or read, respectively.

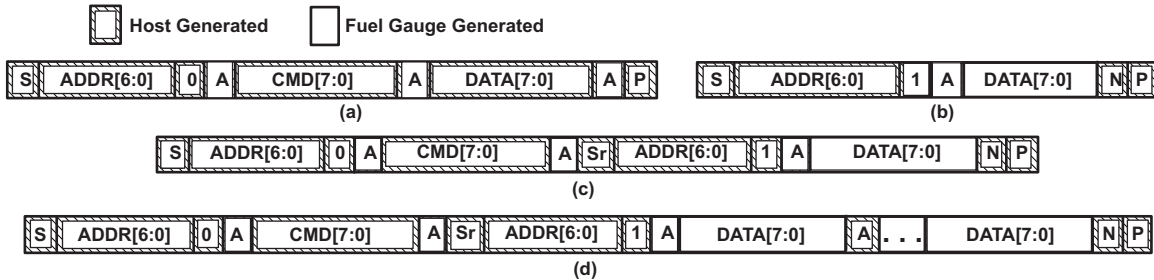

**Figure 5. Supported I<sup>2</sup>C formats: (a) 1-byte write, (b) quick read, (c) 1 byte-read, and (d) incremental read (S = Start, Sr = Repeated Start, A = Acknowledge, N = No Acknowledge, and P = Stop).**

The *quick read* returns data at the address indicated by the address pointer. The address pointer, a register internal to the I<sup>2</sup>C communication engine, increments whenever data is acknowledged by the bq27500 or the I<sup>2</sup>C master. *Quick writes* function in the same manner and are a convenient means of sending multiple bytes to consecutive command locations (such as two-byte commands that require two bytes of data).

Attempt to write a read-only address (NACK after data sent by master):



Attempt to read an address above 0x7F (NACK command):



Attempt at incremental writes (NACK all extra data bytes sent):



Incremental read at the maximum allowed read address:

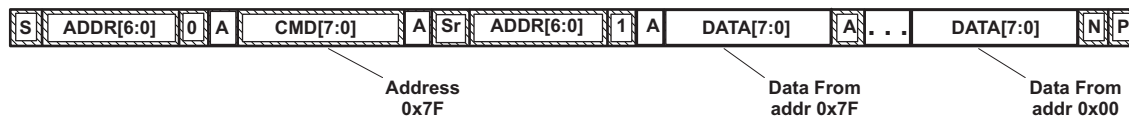

The I<sup>2</sup>C engine releases both SDA and SCL if the I<sup>2</sup>C bus is held low for  $t_{(BUSERR)}$ . If the fuel gauge was holding the lines, releasing them frees the master to drive the lines. If an external condition is holding either of the lines low, the I<sup>2</sup>C engine enters the low-power sleep mode.



### I<sup>2</sup>C Time Out

The I<sup>2</sup>C engine will release both SDA and SCL if the I<sup>2</sup>C bus is held low for about 2 seconds. If the bq27541 was holding the lines, releasing them will free for the master to drive the lines.

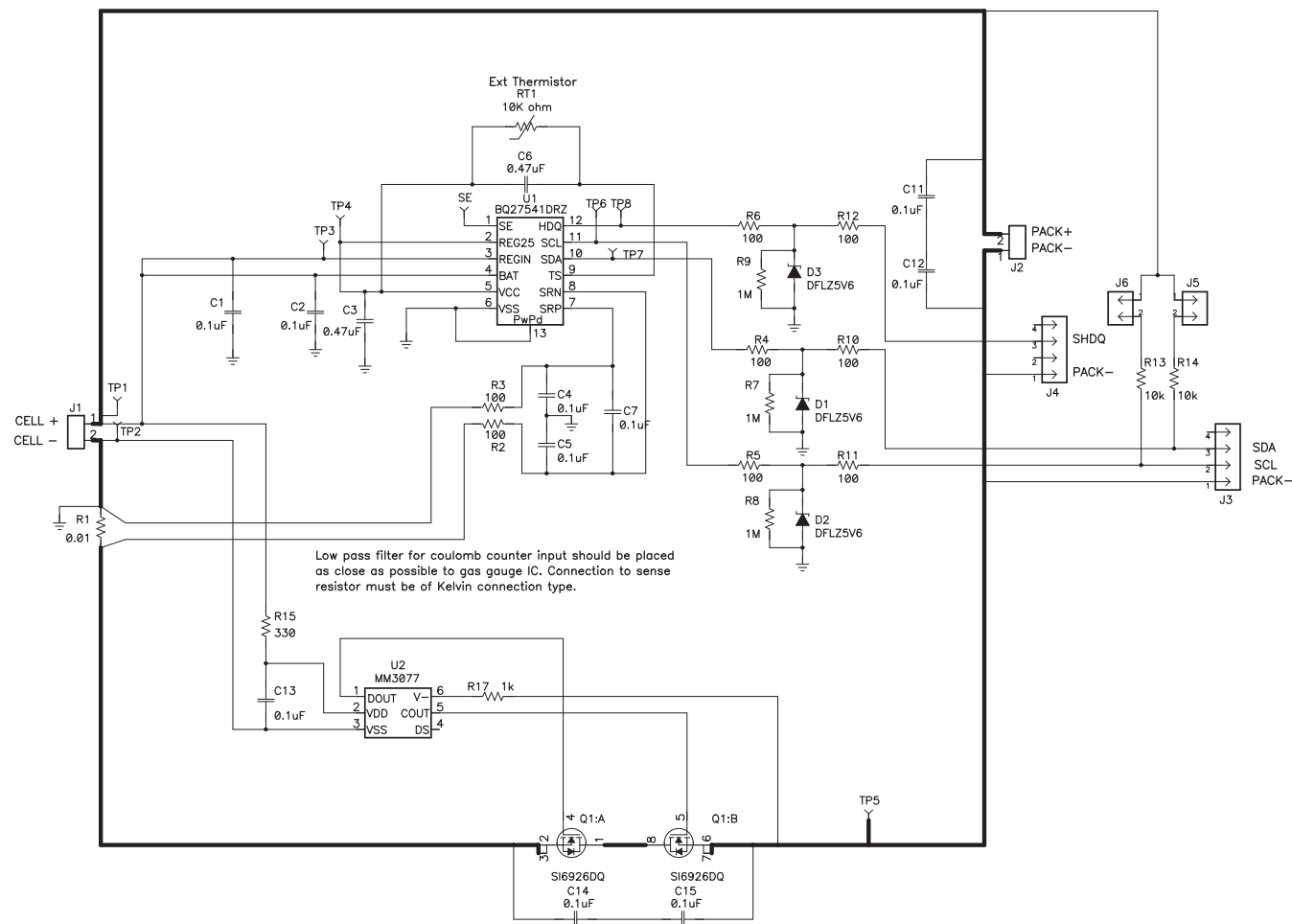
REFERENCE SCHEMATIC



**PACKAGING INFORMATION**

Orderable Device	Status (1)	Package Type	Package Drawing	Pins	Package Qty	Eco Plan (2)	Lead finish/ Ball material (6)	MSL Peak Temp (3)	Op Temp (°C)	Device Marking (4/5)	Samples
BQ27541DRZR	ACTIVE	SON	DRZ	12	3000	RoHS & Green	NIPDAU	Level-2-260C-1 YEAR	-40 to 85	BQ 7541	
BQ27541DRZT	ACTIVE	SON	DRZ	12	250	RoHS & Green	NIPDAU	Level-2-260C-1 YEAR	-40 to 85	BQ 7541	

(1) The marketing status values are defined as follows:

**ACTIVE:** Product device recommended for new designs.

**LIFEBUY:** TI has announced that the device will be discontinued, and a lifetime-buy period is in effect.

**NRND:** Not recommended for new designs. Device is in production to support existing customers, but TI does not recommend using this part in a new design.

**PREVIEW:** Device has been announced but is not in production. Samples may or may not be available.

**OBSOLETE:** TI has discontinued the production of the device.

(2) **RoHS:** TI defines "RoHS" to mean semiconductor products that are compliant with the current EU RoHS requirements for all 10 RoHS substances, including the requirement that RoHS substance do not exceed 0.1% by weight in homogeneous materials. Where designed to be soldered at high temperatures, "RoHS" products are suitable for use in specified lead-free processes. TI may reference these types of products as "Pb-Free".

**RoHS Exempt:** TI defines "RoHS Exempt" to mean products that contain lead but are compliant with EU RoHS pursuant to a specific EU RoHS exemption.

**Green:** TI defines "Green" to mean the content of Chlorine (Cl) and Bromine (Br) based flame retardants meet JS709B low halogen requirements of <=1000ppm threshold. Antimony trioxide based flame retardants must also meet the <=1000ppm threshold requirement.

(3) MSL, Peak Temp. - The Moisture Sensitivity Level rating according to the JEDEC industry standard classifications, and peak solder temperature.

(4) There may be additional marking, which relates to the logo, the lot trace code information, or the environmental category on the device.

(5) Multiple Device Markings will be inside parentheses. Only one Device Marking contained in parentheses and separated by a "~" will appear on a device. If a line is indented then it is a continuation of the previous line and the two combined represent the entire Device Marking for that device.

(6) Lead finish/Ball material - Orderable Devices may have multiple material finish options. Finish options are separated by a vertical ruled line. Lead finish/Ball material values may wrap to two lines if the finish value exceeds the maximum column width.

**Important Information and Disclaimer:**The information provided on this page represents TI's knowledge and belief as of the date that it is provided. TI bases its knowledge and belief on information provided by third parties, and makes no representation or warranty as to the accuracy of such information. Efforts are underway to better integrate information from third parties. TI has taken and continues to take reasonable steps to provide representative and accurate information but may not have conducted destructive testing or chemical analysis on incoming materials and chemicals. TI and TI suppliers consider certain information to be proprietary, and thus CAS numbers and other limited information may not be available for release.

In no event shall TI's liability arising out of such information exceed the total purchase price of the TI part(s) at issue in this document sold by TI to Customer on an annual basis.



## TAPE AND REEL INFORMATION



### QUADRANT ASSIGNMENTS FOR PIN 1 ORIENTATION IN TAPE



\*All dimensions are nominal

Device	Package Type	Package Drawing	Pins	SPQ	Reel Diameter (mm)	Reel Width W1 (mm)	A0 (mm)	B0 (mm)	K0 (mm)	P1 (mm)	W (mm)	Pin1 Quadrant
BQ27541DRZR	SON	DRZ	12	3000	330.0	12.4	2.8	4.3	1.2	4.0	12.0	Q2
BQ27541DRZT	SON	DRZ	12	250	330.0	12.4	2.8	4.3	1.2	4.0	12.0	Q2

**TAPE AND REEL BOX DIMENSIONS**

\*All dimensions are nominal

Device	Package Type	Package Drawing	Pins	SPQ	Length (mm)	Width (mm)	Height (mm)
BQ27541DRZR	SON	DRZ	12	3000	338.1	338.1	20.6
BQ27541DRZT	SON	DRZ	12	250	367.0	367.0	38.0

DRZ (S-PDSO-N12)

PLASTIC SMALL OUTLINE

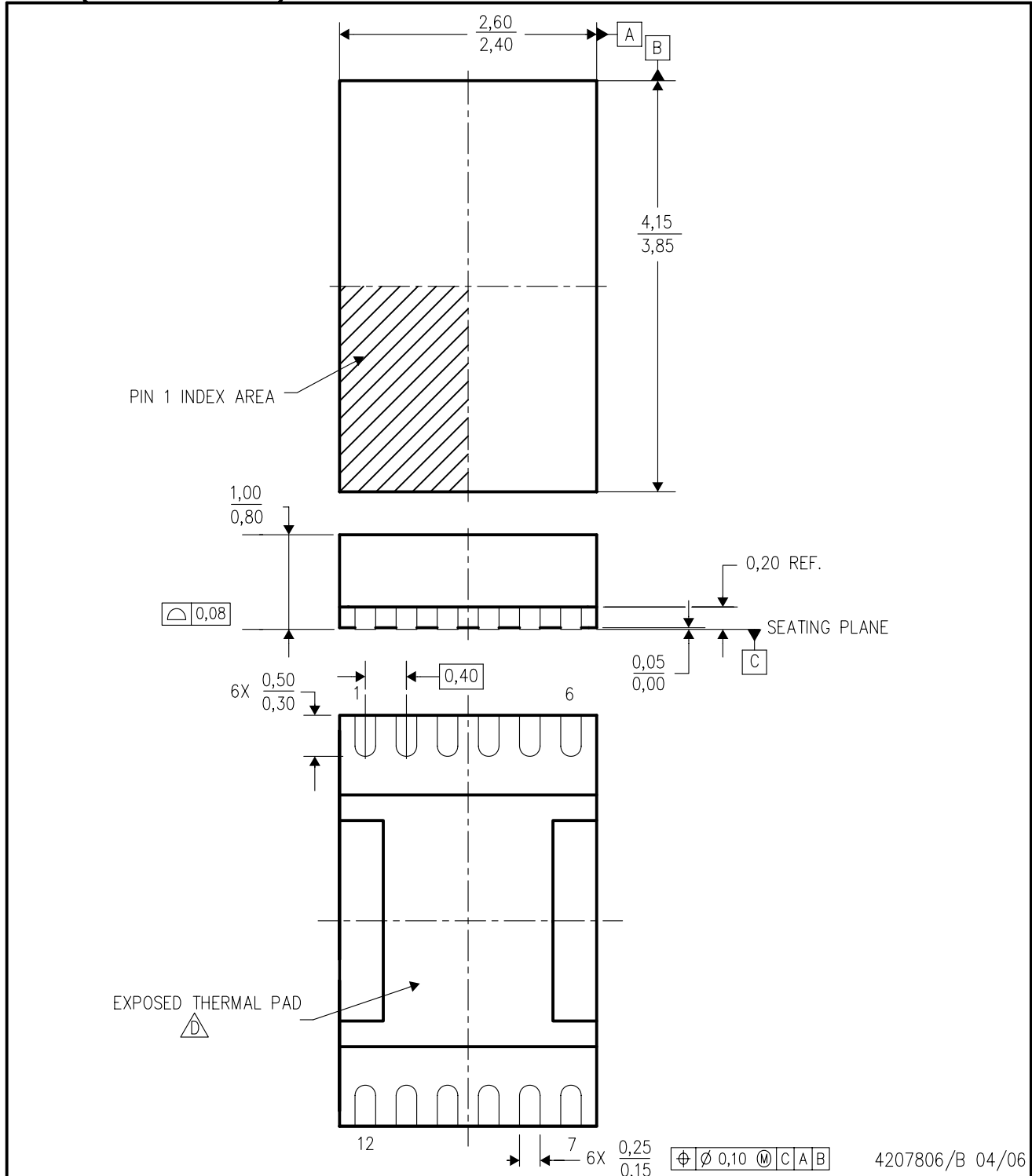

- NOTES:
- A. All linear dimensions are in millimeters. Dimensioning and tolerancing per ASME Y14.5M-1994.
  - B. This drawing is subject to change without notice.
  - C. Small Outline No-Lead (SON) package configuration.
  - D. The package thermal pad must be soldered to the board for thermal and mechanical performance. See the Product Data Sheet for details regarding the exposed thermal pad dimensions.
  - E. This package is lead-free.

DRZ (R-PDSO-N12)

PLASTIC SMALL OUTLINE NO-LEAD

**THERMAL INFORMATION**

This package incorporates an exposed thermal pad that is designed to be attached directly to an external heatsink. The thermal pad must be soldered directly to the printed circuit board (PCB). After soldering, the PCB can be used as a heatsink. In addition, through the use of thermal vias, the thermal pad can be attached directly to the appropriate copper plane shown in the electrical schematic for the device, or alternatively, can be attached to a special heatsink structure designed into the PCB. This design optimizes the heat transfer from the integrated circuit (IC).

For information on the Quad Flatpack No-Lead (QFN) package and its advantages, refer to Application Report, QFN/SON PCB Attachment, Texas Instruments Literature No. SLUA271. This document is available at [www.ti.com](http://www.ti.com).

The exposed thermal pad dimensions for this package are shown in the following illustration.

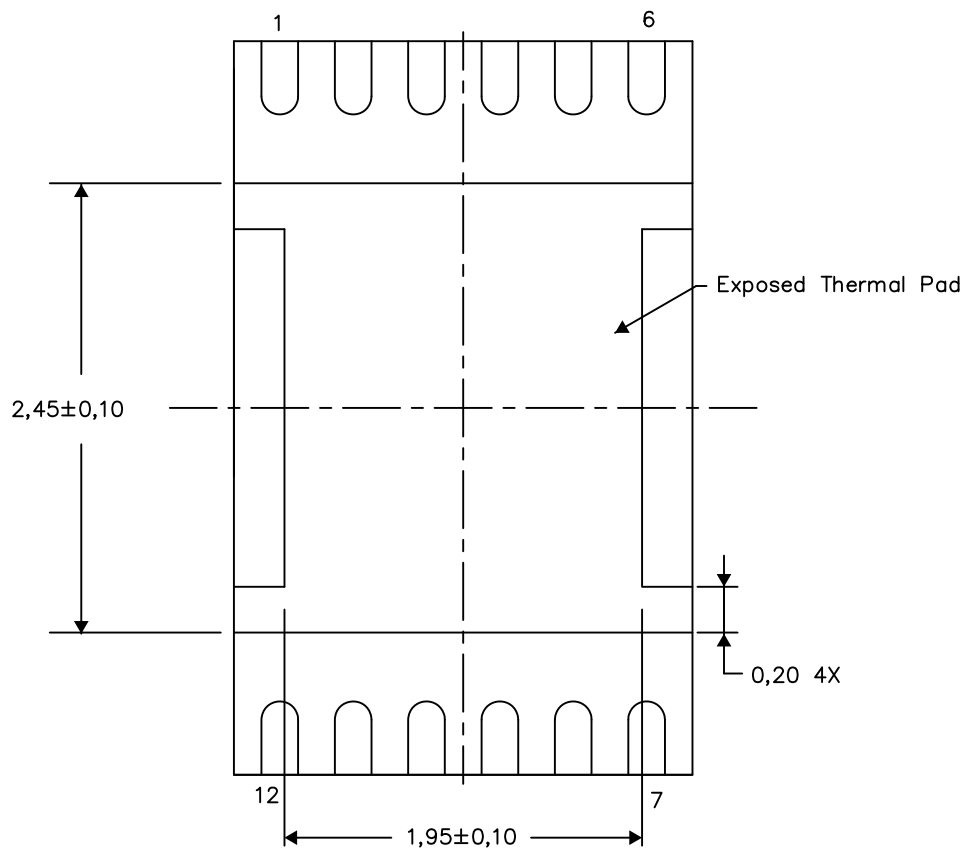

Bottom View  
Exposed Thermal Pad Dimensions

4208114/F 10/14

NOTE: All linear dimensions are in millimeters

DRZ (S-PDSO-N12)

PLASTIC SMALL OUTLINE NO-LEAD

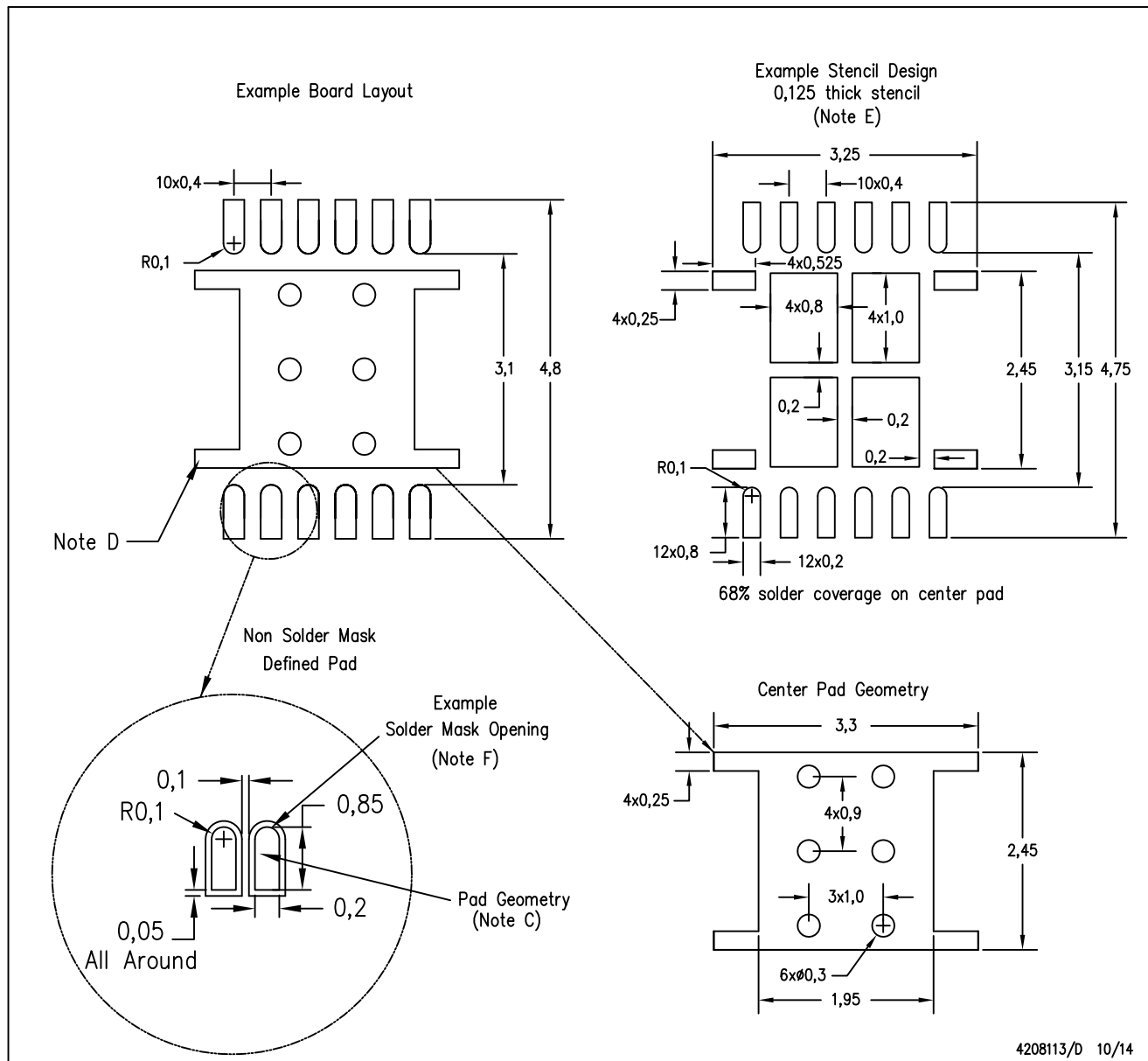

4208113/D 10/14

- NOTES:
- All linear dimensions are in millimeters.
  - This drawing is subject to change without notice.
  - Publication IPC-7351 is recommended for alternate designs.
  - This package is designed to be soldered to a thermal pad on the board. Refer to Application Note, Quad Flat-Pack Packages, Texas Instruments Literature No. SCBA017, SLUA271, and also the Product Data Sheets for specific thermal information, via requirements, and recommended board layout. These documents are available at [www.ti.com](http://www.ti.com) <<http://www.ti.com>>.
  - Laser cutting apertures with trapezoidal walls and also rounding corners will offer better paste release. Customers should contact their board assembly site for stencil design recommendations. Refer to IPC 7525 for stencil design considerations.
  - Customers should contact their board fabrication site for minimum solder mask web tolerances between signal pads.

## IMPORTANT NOTICE AND DISCLAIMER

TI PROVIDES TECHNICAL AND RELIABILITY DATA (INCLUDING DATASHEETS), DESIGN RESOURCES (INCLUDING REFERENCE DESIGNS), APPLICATION OR OTHER DESIGN ADVICE, WEB TOOLS, SAFETY INFORMATION, AND OTHER RESOURCES "AS IS" AND WITH ALL FAULTS, AND DISCLAIMS ALL WARRANTIES, EXPRESS AND IMPLIED, INCLUDING WITHOUT LIMITATION ANY IMPLIED WARRANTIES OF MERCHANTABILITY, FITNESS FOR A PARTICULAR PURPOSE OR NON-INFRINGEMENT OF THIRD PARTY INTELLECTUAL PROPERTY RIGHTS.

These resources are intended for skilled developers designing with TI products. You are solely responsible for (1) selecting the appropriate TI products for your application, (2) designing, validating and testing your application, and (3) ensuring your application meets applicable standards, and any other safety, security, or other requirements. These resources are subject to change without notice. TI grants you permission to use these resources only for development of an application that uses the TI products described in the resource. Other reproduction and display of these resources is prohibited. No license is granted to any other TI intellectual property right or to any third party intellectual property right. TI disclaims responsibility for, and you will fully indemnify TI and its representatives against, any claims, damages, costs, losses, and liabilities arising out of your use of these resources.

TI's products are provided subject to TI's Terms of Sale ([www.ti.com/legal/termsofsale.html](http://www.ti.com/legal/termsofsale.html)) or other applicable terms available either on [ti.com](http://ti.com) or provided in conjunction with such TI products. TI's provision of these resources does not expand or otherwise alter TI's applicable warranties or warranty disclaimers for TI products.

Mailing Address: Texas Instruments, Post Office Box 655303, Dallas, Texas 75265  
Copyright © 2020, Texas Instruments Incorporated