

DP83848x PHYTER Mini / LS Single Port 10/100 MB/s Ethernet Transceiver

1 Device Overview

1.1 Features

- Low-Power 3.3-V, 0.18- μ m CMOS Technology
- Auto-MDIX for 10/100 Mb/s
- Energy Detection Mode
- 3.3-V MAC Interface
- RMII Rev. 1.2 Interface (configurable)
- MII Interface
- MII Serial Management Interface (MDC and MDIO)
- IEEE 802.3 Auto-Negotiation and Parallel Detection
- IEEE 802.3 ENDEC, 10BASE-T Transceivers and Filters
- IEEE 802.3 PCS, 100BASE-TX Transceivers and Filters
- Integrated ANSI X3.263 Compliant TP-PMD Physical Sub-Layer with Adaptive Equalization and Baseline Wander Compensation
- Error-Free Operation Beyond 137 Meters
- ESD Protection – Greater than 4 kV Human Body Model
- Configurable LED for Link and Activity (DP83848J/K)
- 25-MHz Clock Output (DP83848H/M/T)
- Single Register Access for Complete PHY Status
- 10/100 Mb/s Packet BIST (Built-in Self Test)

1.2 Applications

- Peripheral Devices
- Mobile Devices
- Factory and Building Automation
- Base Stations

1.3 Description

The DP83848x device addresses the quality, reliability and small form factor required for space sensitive applications in embedded systems.

The DP83848x offers performance far exceeding the IEEE specifications, with superior interoperability and industry leading performance beyond 137 meters of Cat-V cable. The DP83848x also offers Auto-MDIX to remove cabling complications. DP83848x has superior ESD protection, greater than 4 kV Human Body Model, providing extremely high reliability and robust operation, ensuring a high-level performance in all applications.

DP83848J/K offers two flexible LED indicators one for Link and the other for Speed. In addition, both MII and RMII are supported ensuring ease and flexibility of design.

The DP83848H/M/T incorporates a 25-MHz clock out that eliminates the need and hence the space and cost, of an additional clock source component.

The DP83848x is offered in small 6-mm \times 6-mm WQFN 40-pin package and is ideal for industrial controls, building/factory automation, transportation, test equipment and wire-less base stations.

Device Information⁽¹⁾

PART NUMBER	PACKAGE	BODY SIZE (NOM)
DP83848x	WQFN (40)	6.00 mm \times 6.00 mm

(1) For more information, see [Section 9](#), *Mechanical Packaging and Orderable Information*.



1.4 Functional Block Diagram

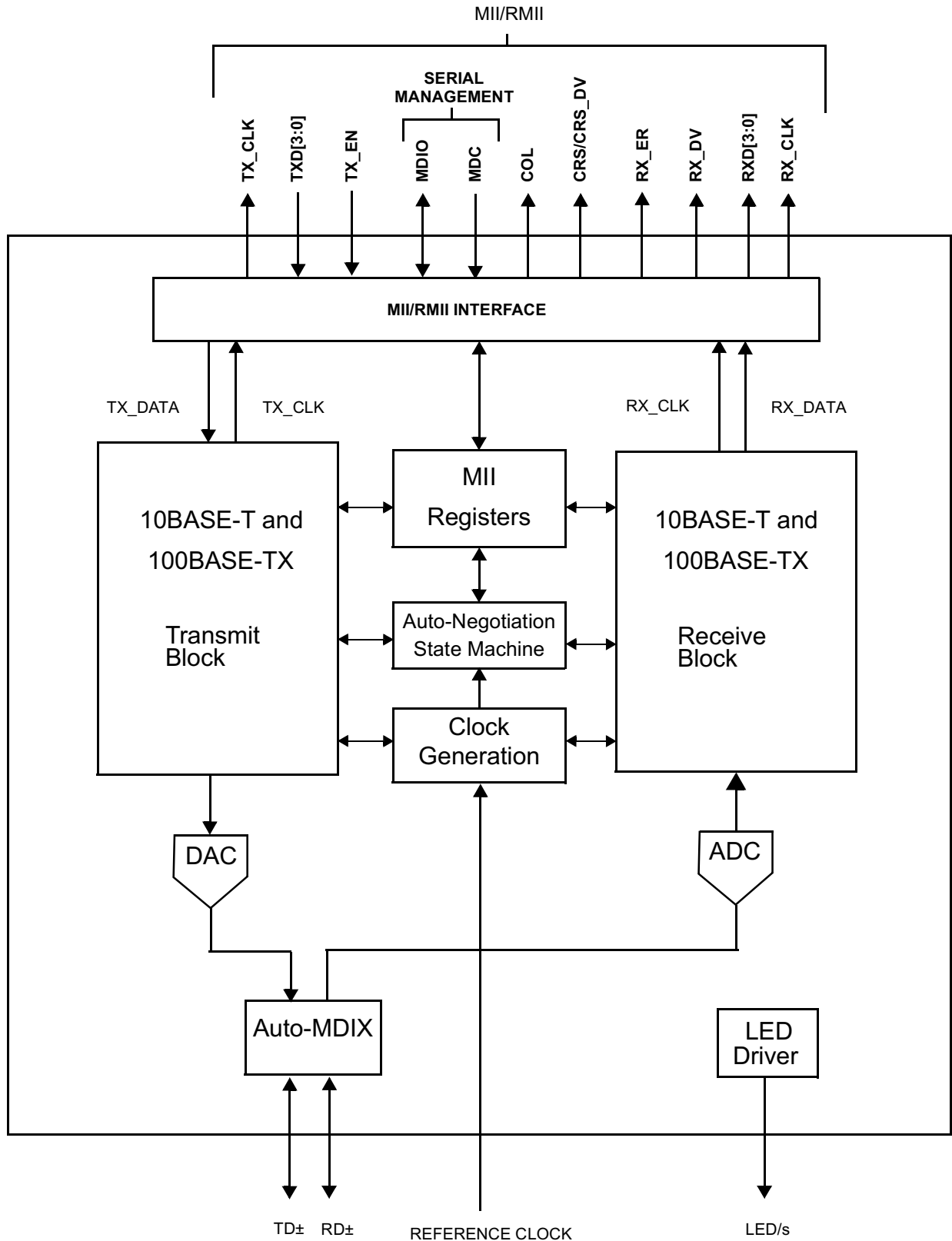

Table of Contents

1	Device Overview	1			
	1.1 Features	1		5.4 Thermal Information.....	10
	1.2 Applications.....	1		5.5 DC Specifications	11
	1.3 Description.....	1		5.6 AC Timing Requirements	11
	1.4 Functional Block Diagram	2		6 Detailed Description	25
2	Revision History	3		6.1 Overview	25
3	Device Comparison	4		6.2 Functional Block Diagram.....	26
4	Pin Configuration and Functions	4		6.3 Feature Description	27
	4.1 Pin Diagram	5		6.4 Device Functional Modes	31
	4.2 Package Pin Assignments.....	6		6.5 Programming	37
	4.3 Serial Management Interface.....	6		6.6 Memory.....	48
	4.4 Mac Data Interface	6	7 Application, Implementation, and Layout	64	
	4.5 Clock Interface	7	7.1 Application Information.....	64	
	4.6 LED Interface.....	7	7.2 Typical Application	64	
	4.7 Reset	8	7.3 Layout	71	
	4.8 Strap Options.....	8	7.4 Power Supply Recommendations.....	75	
	4.9 10 Mb/s and 100 Mb/s PMD Interface	9	8 Device and Documentation Support	76	
	4.10 Special Connections.....	9	8.1 Documentation Support	76	
	4.11 Power Supply Pins	9	8.2 Related Links.....	76	
5	Specifications	10	8.3 Trademarks.....	76	
	5.1 Absolute Maximum Ratings	10	8.4 Electrostatic Discharge Caution.....	76	
	5.2 ESD Ratings	10	8.5 Glossary	76	
	5.3 Recommended Operating Conditions.....	10	9 Mechanical Packaging and Orderable Information	76	

2 Revision History

Changes from Revision D (May 2008) to Revision E	Page
<ul style="list-style-type: none"> • Added <i>ESD Ratings</i> table, <i>Feature Description</i> section, <i>Device Functional Modes</i>, <i>Application and Implementation</i> section, <i>Power Supply Recommendations</i> section, <i>Layout</i> section, <i>Device and Documentation Support</i> section, and <i>Mechanical, Packaging, and Orderable Information</i> section • Added devices DP83848H, DP83848K, DP83848M and DP83848T. 	1
	1

3 Device Comparison

Table 3-1. Device Features⁽¹⁾

DEVICE	TEMPERATURE RANGE		TEMPERATURE GRADE
	MIN	MAX	
DP83848J/M	0°C	70°C	Commercial
DP83848K/T	-40°C	85°C	Industrial
DP83848H	-40°C	125°C	Extreme

(1) Pin 21 is the CLK_OUT pin for the DP83848H/M/T.

4 Pin Configuration and Functions

The DP83848x pins are classified into the following interface categories (each interface is described in the sections that follow):

- Serial Management Interface
- MAC Data Interface
- Clock Interface
- LED Interface
- Reset
- Strap Options
- 10/100 Mb/s PMD Interface
- Special Connections
- Power Supply Pins

NOTE

Strapping pin option. See [Section 4.8](#) for strap definitions.

All DP83848x signal pins are I/O cells regardless of the particular use. The definitions below define the functionality of the I/O cells for each pin.

Type: I Input

Type: O Output

Type: I/O Input/Output

Type: OD Open Drain

Type: PD,PU Internal Pulldown/Pullup

Type: S Strapping Pin (All strap pins have weak internal pullups or pulldowns. If the default strap value is to be changed then an external 2.2-kΩ resistor should be used. See [Section 4.8](#) for details.)

4.1 Pin Diagram

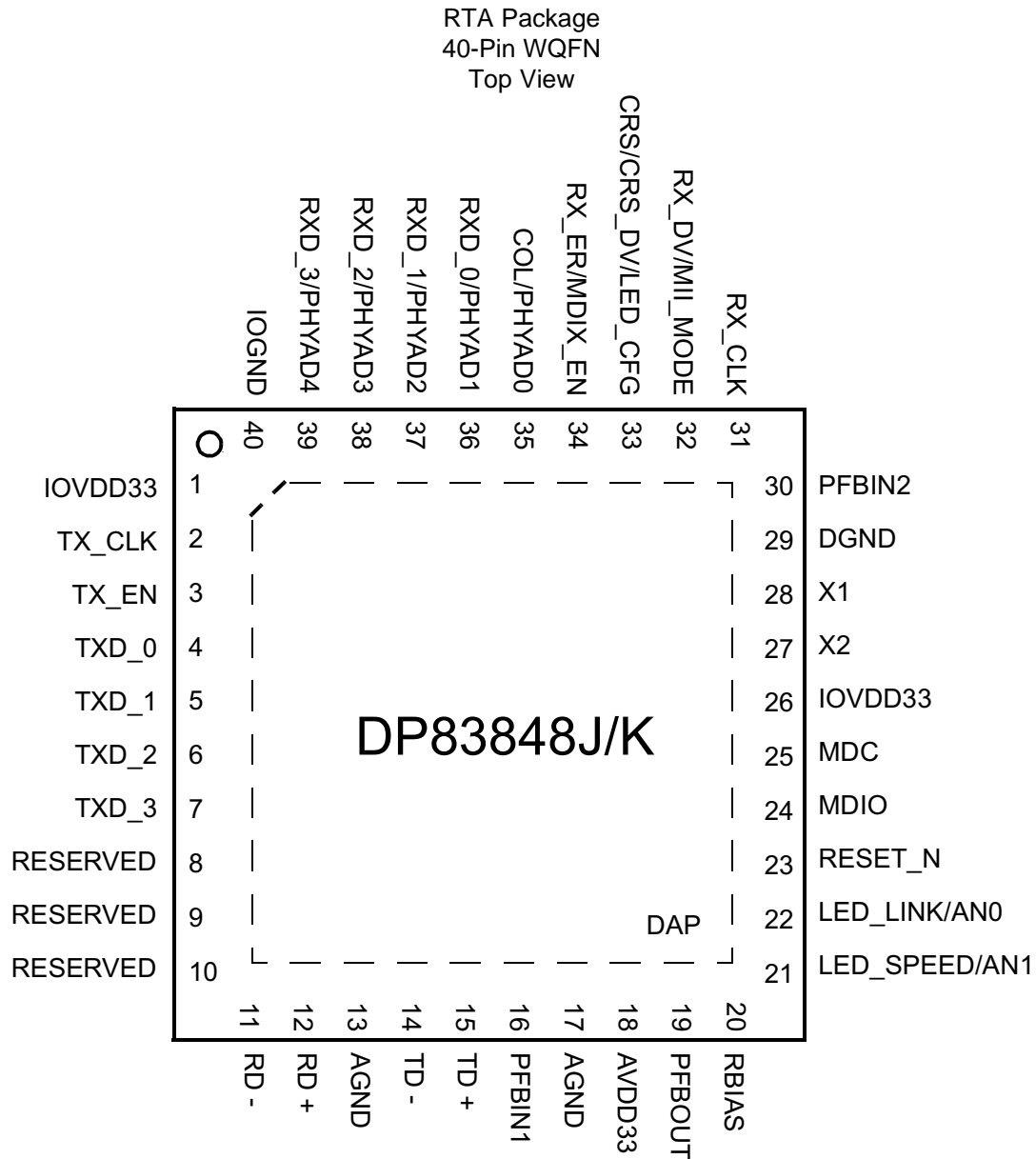

Pin 21 is the CLK_OUT pin for the DP83848H/M/T.

4.2 Package Pin Assignments

NSQAU040 PIN #	PIN NAME (DP83848J)		NSQAU040 PIN #	PIN NAME (DP83848J)
1	IO_VDD		21 ⁽¹⁾	LED_SPEED/AN1
2	TX_CLK		22	LED_LINK/AN0
3	TX_EN		23	RESET_N
4	TXD_0		24	MDIO
5	TXD_1		25	MDC
6	TXD_2		26	IOVDD33
7	TXD_3		27	X2
8	RESERVED		28	X1
9	RESERVED		29	DGND
10	RESERVED		30	PFBIN2
11	RD-		31	RX_CLK
12	RD+		32	RX_DV/MII_MODE
13	AGND		33	CRS/CRS_DV/LED_CFG
14	TD -		34	RX_ER/MDIX_EN
15	TD +		35	COL/PHYAD0
16	PFBIN1		36	RXD_0/PHYAD1
17	AGND		37	RXD_1/PHYAD2
18	AVDD33		38	RXD_2/PHYAD3
19	PFBOUT		39	RXD_3/PHYAD4
20	RBIAS		40	IOGND

(1) Pin 21 is the CLK_OUT pin for the DP83848H/M/T.

4.3 Serial Management Interface

SIGNAL NAME	TYPE	PIN #	DESCRIPTION
MDC	I	25	MANAGEMENT DATA CLOCK: Synchronous clock to the MDIO management data input/output serial interface which may be asynchronous to transmit and receive clocks. The maximum clock rate is 25 MHz with no minimum clock rate.
MDIO	I/O	24	MANAGEMENT DATA I/O: Bi-directional management instruction/data signal that may be sourced by the station management entity or the PHY. This pin requires a 1.5-kΩ pullup resistor.

4.4 Mac Data Interface

SIGNAL NAME	TYPE	PIN #	DESCRIPTION
COL	S, O, PU	35	MII COLLISION DETECT: Asserted high to indicate detection of a collision condition (simultaneous transmit and receive activity) in 10 Mb/s and 100 Mb/s Half-Duplex Modes. While in 10BASE-T Half-Duplex mode with heartbeat enabled this pin is also asserted for a duration of approximately 1 μs at the end of transmission to indicate heartbeat (SQE test). In Full Duplex Mode, for 10 Mb/s or 100 Mb/s operation, this signal is always logic 0. There is no heartbeat function during 10Mb/s full duplex operation. RMII COLLISION DETECT: Per the RMII Specification, no COL signal is required. The MAC will recover CRS from the CRS_DV signal and use that along with its TX_EN signal to determine collision.
CRS/CRS_D V	S, O, PU	33	MII CARRIER SENSE: Asserted high to indicate the receive medium is non-idle. RMII CARRIER SENSE/RECEIVE DATA VALID: This signal combines the RMII Carrier and Receive Data Valid indications. For a detailed description of this signal, see the RMII Specification.
RX_CLK	O	31	MII RECEIVE CLOCK: Provides the 25 MHz recovered receive clocks for 100 Mb/s mode and 2.5 MHz for 10 Mb/s mode. Unused in RMII mode. The device uses the X1 reference clock input as the 50 MHz reference for both transmit and receive.

SIGNAL NAME	TYPE	PIN #	DESCRIPTION
RX_DV	O, PD	32	<p>MII RECEIVE DATA VALID: Asserted high to indicate that valid data is present on the corresponding RXD[3:0].</p> <p>RMII Synchronous Receive Data Valid: This signal provides the RMII Receive Data Valid indication independent of Carrier Sense.</p>
RX_ER	S, O, PU	34	<p>MII RECEIVE ERROR: Asserted high synchronously to RX_CLK to indicate that an invalid symbol has been detected within a received packet in 100 Mb/s mode.</p> <p>RMII RECEIVE ERROR: Assert high synchronously to X1 whenever it detects a media error and RX_DV is asserted in 100 Mb/s mode.</p> <p>This pin is not required to be used by a MAC, in either MII or RMII mode, because the Phy is required to corrupt data on a receive error.</p>
RXD_0 RXD_1 RXD_2 RXD_3	S, O, PD	36 37 38 39	<p>MII RECEIVE DATA: Nibble wide receive data signals driven synchronously to the RX_CLK, 25 MHz for 100 Mb/s mode, 2.5 MHz for 10 Mb/s mode). RXD[3:0] signals contain valid data when RX_DV is asserted.</p> <p>RMII RECEIVE DATA: 2-bits receive data signals, RXD[1:0], driven synchronously to the X1 clock, 50 MHz.</p>
TX_CLK	O	2	<p>MII TRANSMIT CLOCK: 25 MHz Transmit clock output in 100Mb/s mode or 2.5 MHz in 10 Mb/s mode derived from the 25-MHz reference clock.</p> <p>Unused in RMII mode. The device uses the X1 reference clock input as the 50-MHz reference for both transmit and receive.</p>
TX_EN	I, PD	3	<p>MII TRANSMIT ENABLE: Active high input indicates the presence of valid data inputs on TXD[3:0].</p> <p>RMII TRANSMIT ENABLE: Active high input indicates the presence of valid data on TXD[1:0].</p>
TXD_0 TXD_1 TXD_2 TXD_3	I I I I, PD	4 5 6 7	<p>MII TRANSMIT DATA: Transmit data MII input pins, TXD[3:0], that accept data synchronous to the TX_CLK (2.5 MHz in 10 Mb/s mode or 25 MHz in 100 Mb/s mode).</p> <p>RMII TRANSMIT DATA: Transmit data RMII input pins, TXD[1:0], that accept data synchronous to the 50-MHz reference clock.</p>

4.5 Clock Interface

SIGNAL NAME	TYPE	PIN #	DESCRIPTION
X1	I	28	<p>CRYSTAL/OSCILLATOR INPUT: This pin is the primary clock reference input for the DP83848x and must be connected to a 25-MHz 0.005% (+50 ppm) clock source. The DP83848x supports either an external crystal resonator connected across pins X1 and X2, or an external CMOS-level oscillator source connected to pin X1 only.</p> <p>RMII REFERENCE CLOCK: This pin is the primary clock reference input for the RMII mode and must be connected to a 50-MHz 0.005% (+50 ppm) CMOS-level oscillator source.</p>
X2	O	27	<p>CRYSTAL OUTPUT: This pin is the primary clock reference output to connect to an external 25-MHz crystal resonator device. This pin must be left unconnected if an external CMOS oscillator clock source is used.</p>

4.6 LED Interface

SIGNAL NAME	TYPE	PIN #	DESCRIPTION
LED_LINK	S, O, PU	22	<p>LINK LED: In Mode 1, this pin indicates the status of the LINK. The LED will be ON when Link is good.</p> <p>LINK/ACT LED: In Mode 2, this pin indicates transmit and receive activity in addition to the status of the Link. The LED will be ON when Link is good. It will blink when the transmitter or receiver is active.</p>
LED_SPEED	S, O, PU	21	<p>SPEED LED: This LED is ON when DP83848x is in 100 Mb/s and OFF when DP83848x is in 10 Mb/s. Functionality of this LED is independent of the mode selected.⁽¹⁾</p>

(1) LED_SPEED only exists in the DP83848J/K. DP83848M/T/H has CLK_OUT on pin 21.

4.7 Reset

SIGNAL NAME	TYPE	PIN #	DESCRIPTION
RESET_N	I, PU	23	RESET: Active Low input that initializes or re-initializes the DP83848x. Asserting this pin low for at least 1 μ s will force a reset process to occur. All internal registers will re-initialize to their default states as specified for each bit in the Register Block section. All strap options are re-initialized as well.

4.8 Strap Options

DP83848x uses many functional pins as strap options. The values of these pins are sampled during reset and used to strap the device into specific modes of operation. The strap option pin assignments are defined below. The functional pin name is indicated in parentheses.

A 2.2-k Ω resistor should be used for pulldown or pullup to change the default strap option. If the default option is required, then there is no need for external pullup or pulldown resistors. Because these pins may have alternate functions after reset is deasserted, they should not be connected directly to VCC or GND.

SIGNAL NAME	TYPE	PIN #	DESCRIPTION															
PHYAD0 (COL) PHYAD1 (RXD_0) PHYAD2 (RXD_1) PHYAD3 (RXD_2) PHYAD4 (RXD_3)	S, O, PU S, O, PD	35 36 37 38 39	<p>PHY ADDRESS [4:0]: The DP83848x provides five PHY address pins, the state of which are latched into the PHYCTRL register at system Hardware-Reset.</p> <p>The DP83848x supports PHY Address strapping values 0 (<0000>) through 31 (<11111>). A PHY Address of 0 puts the part into the MII Isolate Mode. The MII isolate mode must be selected by strapping Phy Address 0; changing to Address 0 by register write will not put the Phy in the MII isolate mode. Refer to Section 6.4.4 for additional information.</p> <p>PHYAD0 pin has weak internal pullup resistor.</p> <p>PHYAD[4:1] pins have weak internal pulldown resistors.</p>															
AN0 (LED_LINK) AN1 (LED_SPEED) ⁽¹⁾	S, O, PU S, O, PU	22 21	<p>These input pins control the advertised operating mode of the device according to the following table. The value on these pins are set by connecting them to GND (0) or VCC (1) through 2.2-kΩ resistors. These pins should NEVER be connected directly to GND or VCC.</p> <p>The value set at this input is latched into the DP83848x at Hardware-Reset.</p> <p>The float/pulldown status of these pins are latched into the Basic Mode Control Register and the Auto_Negotiation Advertisement Register during Hardware-Reset.</p> <p>The default for DP83848x is 11 because these pins have an internal pullup.</p> <table border="1"> <thead> <tr> <th>AN1⁽¹⁾</th> <th>AN0</th> <th>Advertised Mode</th> </tr> </thead> <tbody> <tr> <td>0</td> <td>0</td> <td>10BASE-T, Half/full-Duplex</td> </tr> <tr> <td>0</td> <td>1</td> <td>100BASE-TX, Half/full-Duplex</td> </tr> <tr> <td>1</td> <td>0</td> <td>10BASE-T, Half-Duplex 100BASE-TX, Half-Duplex</td> </tr> <tr> <td>1</td> <td>1</td> <td>10BASE-T, Half/Full-Duplex 100BASE-TX, Hal/Full-Duplex</td> </tr> </tbody> </table>	AN1 ⁽¹⁾	AN0	Advertised Mode	0	0	10BASE-T, Half/full-Duplex	0	1	100BASE-TX, Half/full-Duplex	1	0	10BASE-T, Half-Duplex 100BASE-TX, Half-Duplex	1	1	10BASE-T, Half/Full-Duplex 100BASE-TX, Hal/Full-Duplex
AN1 ⁽¹⁾	AN0	Advertised Mode																
0	0	10BASE-T, Half/full-Duplex																
0	1	100BASE-TX, Half/full-Duplex																
1	0	10BASE-T, Half-Duplex 100BASE-TX, Half-Duplex																
1	1	10BASE-T, Half/Full-Duplex 100BASE-TX, Hal/Full-Duplex																
MII_MODE (RX_DV)	S, O, PD	32	<p>MII MODE SELECT: This strapping option determines the operating mode of the MAC Data Interface. Default operation (No pullup) will enable normal MII Mode of operation. Strapping MII_MODE high will cause the device to be in RMII mode of operation. Because the pin includes an internal pulldown, the default value is 0.</p> <p>The following table details the configuration:</p> <table border="1"> <thead> <tr> <th>MIL_MODE</th> <th>MAC Interface Mode</th> </tr> </thead> <tbody> <tr> <td>0</td> <td>MII Mode</td> </tr> <tr> <td>1</td> <td>RMII Mode</td> </tr> </tbody> </table>	MIL_MODE	MAC Interface Mode	0	MII Mode	1	RMII Mode									
MIL_MODE	MAC Interface Mode																	
0	MII Mode																	
1	RMII Mode																	
LED_CFG (CRS/CRS_DV)	S, O, PU	33	<p>LED CONFIGURATION: This strapping option determines the mode of operation of the LED pins. Default is Mode 1. Mode 1 and Mode 2 can be controlled through the strap option. All modes are configurable through register access.</p> <p>See Table 6-2 for LED Mode Selection.</p>															
MDIX_EN (RX_ER)	S, O, PU	34	<p>MDIX ENABLE: Default is to enable MDIX. This strapping option disables Auto-MDIX. An external pulldown will disable Auto-MDIX mode.</p>															

(1) AN1 (LED_SPEED) is only available on the DP83848J/K.

4.9 10 Mb/s and 100 Mb/s PMD Interface

SIGNAL NAME	TYPE	PIN #	DESCRIPTION
TD-, TD+	I/O	14, 15	Differential common driver transmit output (PMD Output Pair). These differential outputs are automatically configured to either 10BASE-T or 100BASE-TX signaling. In Auto-MDIX mode of operation, this pair can be used as the Receive Input pair. These pins require 3.3-V bias for operation.
RD-, RD+	I/O	11, 12	Differential receive input (PMD Input Pair). These differential inputs are automatically configured to accept either 100BASE-TX or 10BASE-T signaling. In Auto-MDIX mode of operation, this pair can be used as the Transmit Output pair. These pins require 3.3-V bias for operation.

4.10 Special Connections

SIGNAL NAME	TYPE	PIN #	DESCRIPTION
RBIAS	I	20	Bias Resistor Connection. A 4.87-k Ω 1% resistor should be connected from RBIAS to GND.
PFBOU	O	19	Power Feedback Output. Parallel caps, 10 μ F (Tantalum preferred) and 0.1 μ F, should be placed close to the PFBOU. Connect this pin to PFBIN1 (pin 16) and PFBIN2 (pin 30). See Section 7.2.1.3 for proper placement pin.
PFBIN1 PFBIN2	I	16 30	Power Feedback Input. These pins are fed with power from PFBOU pin. A small capacitor of 0.1 μ F should be connected close to each pin. <i>Note: Do not supply power to these pins other than from PFBOU.</i>
RESERVED	I/O	8,9,10	RESERVED: These pins must be left unconnected.

4.11 Power Supply Pins

SIGNAL NAME	PIN #	DESCRIPTION
IOVDD33	1, 26	I/O 3.3-V Supply
IOGND	40	I/O Ground
DGND	29	Digital Ground
AVDD33	18	Analog 3.3-V Supply
AGND	13, 17	Analog Ground

5 Specifications

5.1 Absolute Maximum Ratings

over operating free-air temperature range (unless otherwise noted) ⁽¹⁾⁽²⁾

		MIN	MAX	UNIT
V _{CC}	Supply voltage	-0.5	4.2	V
V _{IN}	DC input voltage	-0.5	V _{CC} + 0.5	V
V _{OUT}	DC output voltage	-0.5	V _{CC} + 0.5	V
	Max case temperature		147.7	°C
T _J	Max die temperature		150	°C
T _{stg}	Storage temperature	-65	150	°C

- (1) Stresses beyond those listed under *Absolute Maximum Ratings* may cause permanent damage to the device. These are stress ratings only, which do not imply functional operation of the device at these or any other conditions beyond those indicated under *Recommended Operating Conditions*. Exposure to absolute-maximum-rated conditions for extended periods may affect device reliability.
- (2) All parameters are specified by test, statistical analysis or design.

5.2 ESD Ratings

		VALUE	UNIT
V _(ESD)	Electrostatic discharge	Human body model (HBM), per ANSI/ESDA/JEDEC JS-001 ⁽¹⁾⁽²⁾	±4000
		Charged device model (CDM), per JEDEC specification JESD22-C101 ⁽³⁾	±1000

- (1) JEDEC document JEP155 states that 500-V HBM allows safe manufacturing with a standard ESD control process.
- (2) R_{ZAP} = 1.5 kΩ, C_{ZAP} = 120 pF
- (3) JEDEC document JEP157 states that 250-V CDM allows safe manufacturing with a standard ESD control process.

5.3 Recommended Operating Conditions

over operating free-air temperature range (unless otherwise noted)

		MIN	NOM	MAX	UNIT
V _{CC}	Supply voltage	3.3		±0.3	V
T _A	Ambient temperature	Commerical - DP83848J/M		70	°C
		Industrial - DP83848K/T		85	
		Extreme - DP83848H		125	
P _D	Power dissipation			264	mW

5.4 Thermal Information

THERMAL METRIC ⁽¹⁾	DP83848x	UNIT	
	RTA [WQFN]		
	40 PINS		
R _{θJA}	Junction-to-ambient thermal resistance	31.7	°C/W
R _{θJC(top)}	Junction-to-case (top) thermal resistance	8.8	
R _{θJB}	Junction-to-board thermal resistance	40.5	
ψ _{JT}	Junction-to-top characterization parameter	0.4	
ψ _{JB}	Junction-to-board characterization parameter	10.5	
R _{θJC(bot)}	Junction-to-case (bottom) thermal resistance	5.5	

- (1) For more information about traditional and new thermal metrics, see the *IC Package Thermal Metrics* application report, [SPRA953](#).

5.5 DC Specifications

over operating free-air temperature range (unless otherwise noted)

PARAMETER		TEST CONDITIONS	PIN TYPES	MIN	TYP	MAX	UNIT
V _{IH}	Input high voltage	Nominal V _{CC}	I I/O	2			V
V _{IL}	Input low voltage		I I/O			0.8	V
I _{IH}	Input high current	V _{IN} = V _{CC}	I I/O			10	μA
I _{IL}	Input low current	V _{IN} = GND	I I/O			10	μA
V _{OL}	Output low voltage	I _{OL} = 4 mA	O, I/O			0.4	V
V _{OH}	Output high voltage	I _{OH} = -4 mA	O, I/O	V _{CC} - 0.5			V
V _{IedOL}	Output low voltage	I _{OL} = 2.5 mA	LED			0.4	V
V _{IedOH}	Output high voltage	I _{OH} = -2.5 mA	LED	V _{CC} - 0.5			V
I _{OZ}	Tri-state leakage	V _{OUT} = V _{CC}	I/O, O			±10	μA
V _{TPTD_100}	100M Transmit voltage		PMD Output	0.95	1	1.05	V
V _{TPTDsym}	100M Transmit voltage symmetry		PMD Output Pair			±2%	
V _{TPTD_10}	10M Transmit voltage		PMD Output Pair	2.2	2.5	2.8	V
C _{IN1}	CMOS Input capacitance		I		5		pF
C _{OUT1}	CMOS Output capacitance		O		5		pF
SD _{THon}	100BASE-TX Signal detect turnon threshold		PMD Input Pair			1000	mV diff pk-pk
SD _{THoff}	100BASE-TX Signal detect turnoff threshold		PMD Input Pair	200			mV diff pk-pk
V _{TH1}	10BASE-T Receive Threshold		PMD Input Pair			585	mV
I _{dd100}	100BASE-TX (Full Duplex)	I _{OUT} = 0 mA ⁽¹⁾	PMD Input Pair		81		mA
I _{dd10}	10BASE-T (Full Duplex)		Supply		92		

(1) Refer to application note SNLA089, "Power Measurement of Ethernet Physical Layer Products"

5.6 AC Timing Requirements

			MIN	NOM	MAX	UNIT
POWER UP TIMING (REFER TO Figure 5-1)⁽¹⁾						
T2.1.1	Post Power Up Stabilization time prior to MDC preamble for register accesses	MDIO is pulled high for 32-bit serial management initialization. X1 Clock must be stable for a minimum of 167 ms at power up.	167			ms
T2.1.2	Hardware Configuration Latch-in Time from power up	Hardware Configuration Pins are described in Section 4 . X1 Clock must be stable for a minimum of 167 ms at power up.	167			ms
T2.1.3	Hardware Configuration pins transition to output drivers			50		ns
RESET TIMING (REFER TO Figure 5-2)⁽²⁾						
T2.2.1	Post RESET Stabilization time prior to MDC preamble for register accesses	MDIO is pulled high for 32-bit serial management initialization.		3		μs
T2.2.2	Hardware Configuration Latch-in Time from the Deassertion of RESET (either soft or hard)	Hardware Configuration Pins are described in Section 4 .		3		μs
T2.2.3	Hardware Configuration pins transition to output drivers			50		ns
T2.2.4	RESET pulse width	X1 Clock must be stable for at minimum of 1 μs during RESET pulse low time.	1			μs
MII SERIAL MANAGEMENT TIMING (REFER TO Figure 5-3)						
T2.3.1	MDC to MDIO (Output) Delay Time		0		30	ns
T2.3.2	MDIO (Input) to MDC Setup Time		10			ns
T2.3.3	MDIO (Input) to MDC Hold Time		10			ns
T2.3.4	MDC Frequency			2.5	25	MHz

(1) In RMI Mode, the minimum Post Power up Stabilization and Hardware Configuration Latch-in times are 84 ms.

(2) It is important to choose pullup and/or pulldown resistors for each of the hardware configuration pins that provide fast RC time constants in order to latch-in the proper value prior to the pin transitioning to an output driver.

AC Timing Requirements (continued)

			MIN	NOM	MAX	UNIT
100 Mb/s MII TRANSMIT TIMING (REFER TO Figure 5-4)						
T2.4.1	TX_CLK High/Low Time	100 Mb/s Normal mode	16	20	24	ns
T2.4.2	TXD[3:0], TX_EN Data Setup to TX_CLK	100 Mb/s Normal mode	10			ns
T2.4.3	TXD[3:0], TX_EN Data Hold from TX_CLK	100 Mb/s Normal mode	0			ns
100 Mb/s MII RECEIVE TIMING (REFER TO Figure 5-5)⁽³⁾						
T2.5.1	RX_CLK High/Low Time	100 Mb/s Normal mode	16	20	24	ns
T2.5.2	RX_CLK to RXD[3:0], RX_DV, RX_ER Delay	100 Mb/s Normal mode	10		30	ns
100BASE-TX TRANSMIT PACKET LATENCY TIMING (REFER TO Figure 5-6)⁽⁴⁾						
T2.6.1	TX_CLK to PMD Output Pair Latency	100 Mb/s Normal mode		6		bits
100BASE-TX TRANSMIT PACKET DEASSERTION TIMING (REFER TO Figure 5-7)⁽⁵⁾						
T2.7.1	TX_CLK to PMD Output Pair Deassertion	100 Mb/s Normal mode		6		bits
100BASE-TX TRANSMIT TIMING (t_{R/F}) AND JITTER (REFER TO Figure 5-8)⁽⁶⁾⁽⁷⁾						
T2.8.1	100 Mb/s PMD Output Pair t _R and t _F		3	4	5	ns
	100 Mb/s t _R and t _F Mismatch				500	ps
T2.8.2	100 Mb/s PMD Output Pair Transmit Jitter				1.4	ns
100BASE-TX RECEIVE PACKET LATENCY TIMING (REFER TO Figure 5-9)⁽⁸⁾⁽⁹⁾⁽¹⁰⁾						
T2.9.1	Carrier Sense ON Delay	100 Mb/s Normal mode		20		bits
T2.9.2	Receive Data Latency	100 Mb/s Normal mode		24		bits
100BASE-TX RECEIVE PACKET DEASSERTION TIMING (REFER TO Figure 5-10)⁽⁹⁾⁽¹¹⁾						
T2.10.1	Carrier Sense OFF Delay	100 Mb/s Normal mode		24		bits
10 Mb/s MII TRANSMIT TIMING (REFER TO Figure 5-11)⁽¹²⁾						
T2.11.1	TX_CLK High/Low Time	10 Mb/s MII mode	190	200	210	ns
T2.11.2	TXD[3:0], TX_EN Data Setup to TX_CLK fall	10 Mb/s MII mode	25			ns
T2.11.3	TXD[3:0], TX_EN Data Hold from TX_CLK rise	10 Mb/s MII mode	0			ns
10 Mb/s MII RECEIVE TIMING (REFER TO Figure 5-12)⁽¹³⁾						
T2.12.1	RX_CLK High/Low Time		160	200	240	ns
T2.12.2	RX_CLK to RXD[3:0], RX_DV Delay	10 Mb/s MII mode	100			ns
T2.12.3	RX_CLK rising edge delay from RXD[3:0], RX_DV Valid	10 Mb/s MII mode	100			ns
10BASE-T TRANSMIT TIMING (START OF PACKET) (REFER TO Figure 5-13)⁽¹⁴⁾						
T2.13.1	Transmit Output Delay from the Falling Edge of TX_CLK	10 Mb/s MII mode		3.5		bits
10BASE-T TRANSMIT TIMING (END OF PACKET) (REFER TO Figure 5-14)						
T2.14.1	End of Packet High Time (with 0 ending bit)		250	300		ns
T2.14.2	End of Packet High Time (with 1 ending bit)		250	300		ns
10BASE-T RECEIVE TIMING (START OF PACKET) (REFER TO Figure 5-15)⁽¹⁴⁾⁽¹⁵⁾						
T2.15.1	Carrier Sense Turnon Delay (PMD Input Pair to CRS)			630	1000	ns
T2.15.2	RX_DV Latency			10		bits

- (3) RX_CLK may be held low or high for a longer period of time during transition between reference and recovered clocks. Minimum high and low times will not be violated.
- (4) For Normal mode, latency is determined by measuring the time from the first rising edge of TX_CLK occurring after the assertion of TX_EN to the first bit of the “J” code group as output from the PMD Output Pair. 1 bit time = 10 ns in 100 Mb/s mode.
- (5) Deassertion is determined by measuring the time from the first rising edge of TX_CLK occurring after the deassertion of TX_EN to the first bit of the “T” code group as output from the PMD Output Pair. 1 bit time = 10 ns in 100 Mb/s mode.
- (6) Normal Mismatch is the difference between the maximum and minimum of all rise and fall times.
- (7) Rise and fall times taken at 10% and 90% of the +1 or -1 amplitude.
- (8) Carrier Sense On Delay is determined by measuring the time from the first bit of the “J” code group to the assertion of Carrier Sense.
- (9) 1 bit time = 10 ns in 100 Mb/s mode.
- (10) PMD Input Pair voltage amplitude is greater than the Signal Detect Turnon Threshold Value.
- (11) Carrier Sense Off Delay is determined by measuring the time from the first bit of the “T” code group to the deassertion of Carrier Sense.
- (12) An attached Mac should drive the transmit signals using the positive edge of TX_CLK. As shown above, the MII signals are sampled on the falling edge of TX_CLK.
- (13) RX_CLK may be held low for a longer period of time during transition between reference and recovered clocks. Minimum high and low times will not be violated.
- (14) 1 bit time = 100 ns in 10 Mb/s mode.
- (15) 10BASE-T RX_DV Latency is measured from first bit of preamble on the wire to the assertion of RX_DV

AC Timing Requirements (continued)

			MIN	NOM	MAX	UNIT
T2.15.3	Receive Data Latency	Measurement shown from SFD		8		bits
10BASE-T RECEIVE TIMING (END OF PACKET) (REFER TO Figure 5-16)						
T2.16.1	Carrier Sense Turn Off Delay				1	µs
10Mb/s HEARTBEAT TIMING (REFER TO Figure 5-17)						
T2.17.1	CD Heartbeat Delay	All 10 Mb/s modes		1200		ns
T2.17.2	CD Heartbeat Duration	All 10 Mb/s modes		1000		ns
10 Mb/s JABBER TIMING (REFER TO Figure 5-18)						
T2.18.1	Jabber Activation Time			85		ms
T2.18.2	Jabber Deactivation Time			500		ms
10BASE-T NORMAL LINK PULSE TIMING (REFER TO Figure 5-19)⁽¹⁶⁾						
T2.19.1	Pulse Width			100		ns
T2.19.2	Pulse Period			16		ms
AUTO-NEGOTIATION FAST LINK PULSE (FLP) TIMING (REFER TO Figure 5-20)⁽¹⁶⁾						
T2.20.1	Clock, Data Pulse Width			100		ns
T2.20.2	Clock Pulse to Clock Pulse Period			125		µs
T2.20.3	Clock Pulse to Data Pulse Period	Data = 1		62		µs
T2.20.4	Burst Width			2		ms
T2.20.5	FLP Burst to FLP Burst Period			16		ms
100BASE-TX SIGNAL DETECT TIMING (REFER TO Figure 5-22)⁽¹⁷⁾						
T2.21.1	SD Internal Turnon Time				1	ms
T2.21.2	SD Internal Turnoff Time				350	µs
100 Mb/s INTERNAL LOOPBACK TIMING (REFER TO Figure 5-22)⁽¹⁸⁾⁽¹⁹⁾						
T2.22.1	TX_EN to RX_DV Loopback	100 Mb/s internal loopback mode			240	ns
10 Mb/s INTERNAL LOOPBACK TIMING (REFER TO Figure 5-23)⁽¹⁹⁾						
T2.23.1	TX_EN to RX_DV Loopback	10 Mb/s internal loopback mode			2	µs
RMII TRANSMIT TIMING (REFER TO Figure 5-24)						
T2.24.1	X1 Clock Period	50-MHz Reference Clock		20		ns
T2.24.2	TXD[1:0], TX_EN, Data Setup to X1 rising			4		ns
T2.24.3	TXD[1:0], TX_EN, Data Hold from X1 rising			2		ns
T2.24.4	X1 Clock to PMD Output Pair Latency	From X1 Rising edge to first bit of symbol		17		bits
RMII RECEIVE TIMING (REFER TO Figure 5-25)⁽²⁰⁾⁽²¹⁾⁽²²⁾⁽²³⁾⁽²⁴⁾⁽²⁵⁾						
T2.25.1	X1 Clock Period	50-MHz Reference Clock		20		ns
T2.25.2	RXD[1:0], CRS_DV, RX_DV, and RX_ER output delay from X1 rising			2	14	ns
T2.25.3	CRS ON delay	From JK symbol on PMD Receive Pair to initial assertion of CRS_DV		18.5		bits
T2.25.4	CRS OFF delay	From TR symbol on PMD Receive Pair to initial deassertion of CRS_DV		27		bits
T2.25.5	RXD[1:0] and RX_ER latency	From symbol on Receive Pair. Elasticity buffer set to default value (01)		38		bits

(16) These specifications represent transmit timings.

(17) The signal amplitude on PMD Input Pair must be TP-PMD compliant.

(18) Due to the nature of the descrambler function, all 100BASE-TX Loopback modes will cause an initial "dead-time" of up to 550 µs during which time no data will be present at the receive MII outputs. The 100BASE-TX timing specified is based on device delays after the initial 550 µs "dead-time".

(19) Measurement is made from the first rising edge of TX_CLK after assertion of TX_EN.

(20) Per the RMII Specification, output delays assume a 25-pF load.

(21) CRS_DV is asserted asynchronously in order to minimize latency of control signals through the Phy. CRS_DV may toggle synchronously at the end of the packet to indicate CRS deassertion.

(22) RX_DV is synchronous to X1. While not part of the RMII specification, this signal is provided to simplify recovery of receive data.

(23) CRS ON delay is measured from the first bit of the JK symbol on the PMD Input Pair to initial assertion of CRS_DV.

(24) CRS OFF delay is measured from the first bit of the TR symbol on the PMD Input Pair to initial deassertion of CRS_DV.

(25) Receive Latency is measured from the first bit of the symbol pair on the PMD Input Pair. Typical values are with the Elasticity Buffer set to the default value (01).

AC Timing Requirements (continued)

		MIN	NOM	MAX	UNIT
ISOLATION TIMING (REFER TO Figure 5-26)					
T2.26.1	From software clear of bit 10 in the BMCR register to the transition from Isolate to Normal Mode			100	μs
T2.26.2	From Deassertion of S/W or H/W Reset to transition from Isolate to Normal mode			500	μs
100 Mb/s X1 TO TX_CLK TIMING (REFER TO Figure 5-27)⁽²⁶⁾					
T2.27.1	X1 to TX_CLK delay		100 Mb/s Normal mode	0	5
					ns

(26) X1 to TX_CLK timing is provided to support devices that use X1 instead of TX_CLK as the reference for transmit MII data.

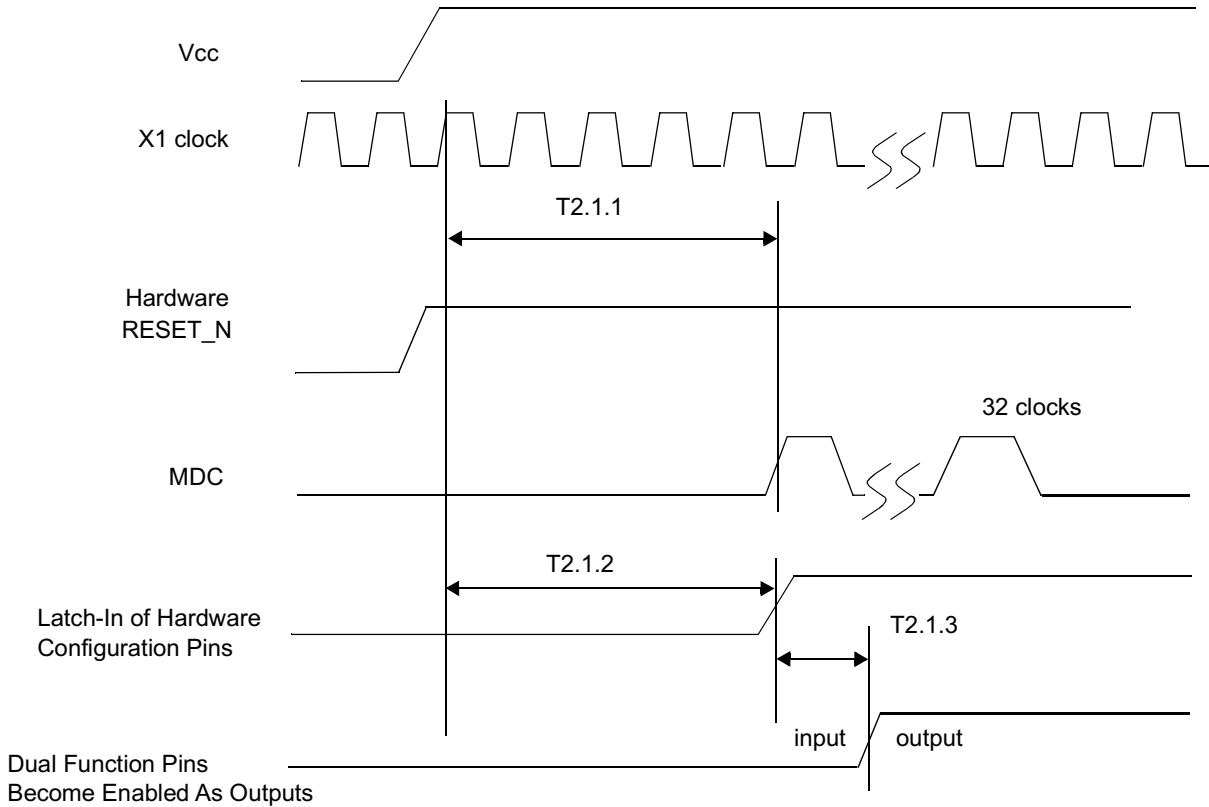

Figure 5-1. Power Up Timing

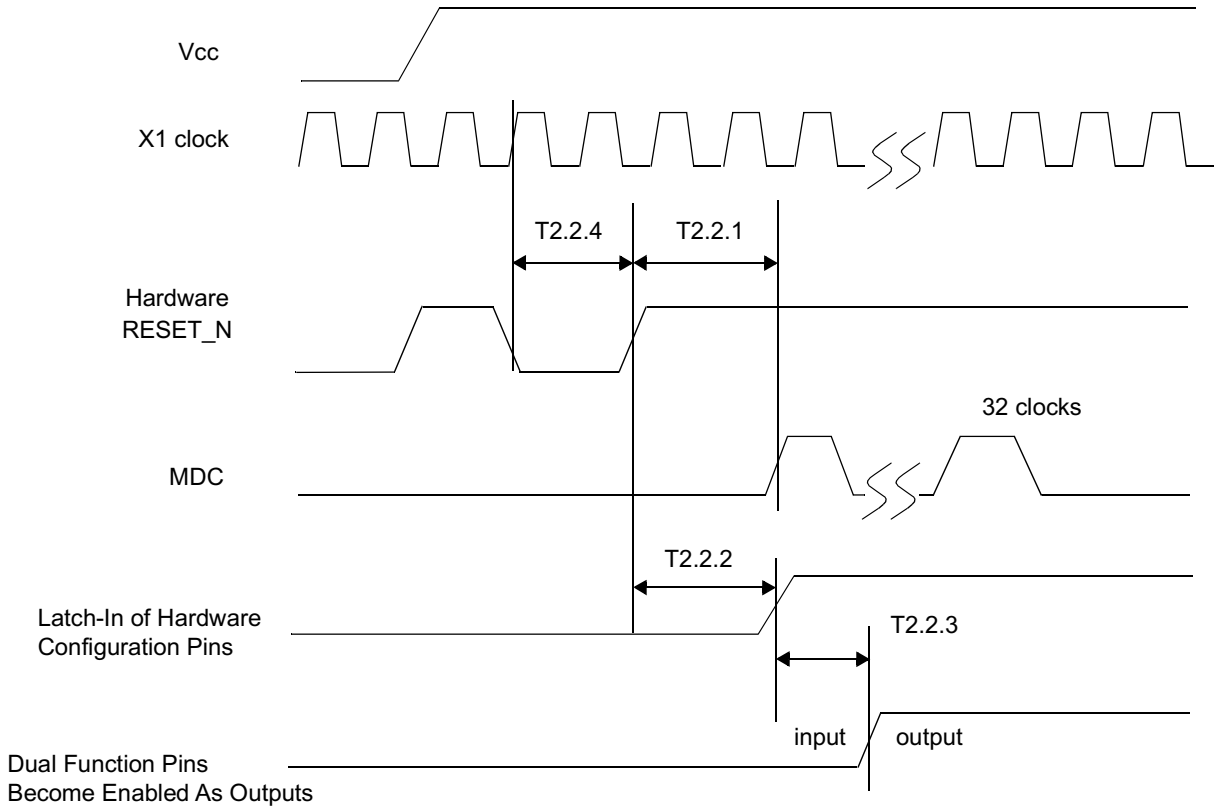

Figure 5-2. Reset Timing

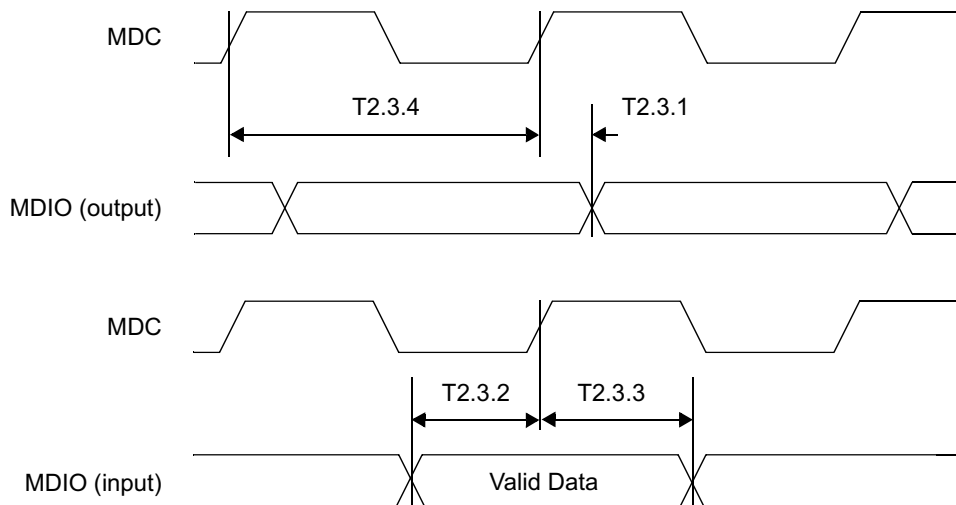

Figure 5-3. MII Serial Management Timing

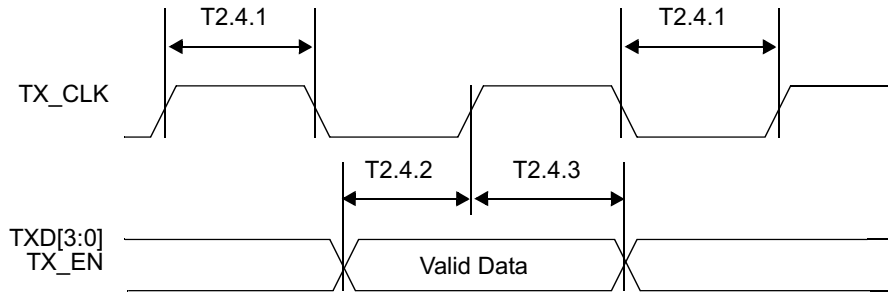

Figure 5-4. 100 Mb/s MII Transmit Timing

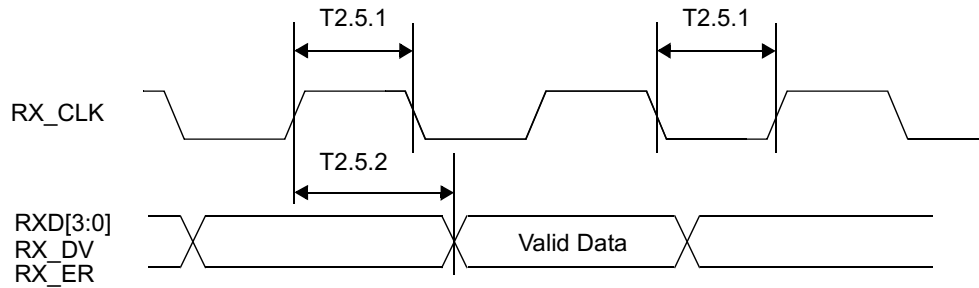

Figure 5-5. 100 Mb/s MII Receive Timing

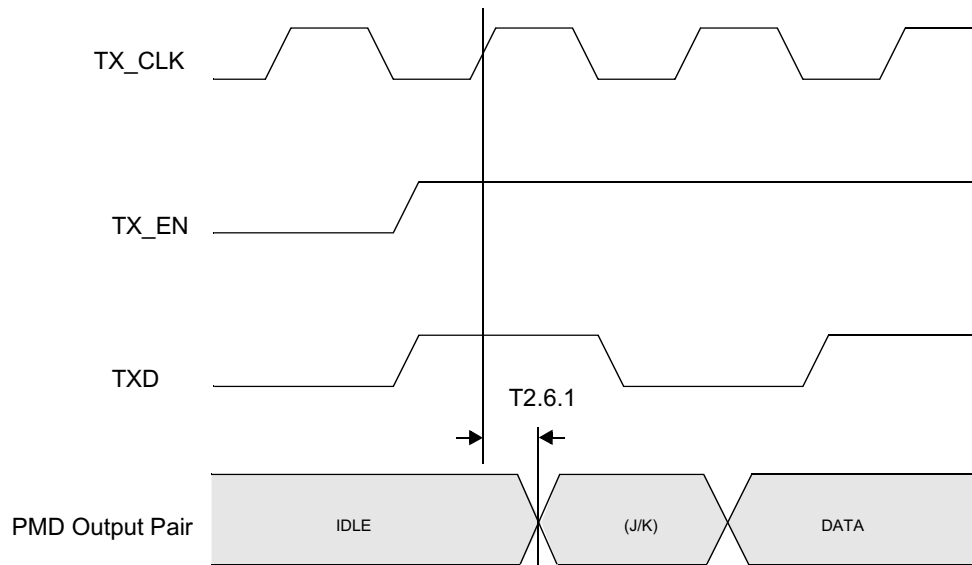

Figure 5-6. 100BASE-TX Transmit Packet Latency Timing

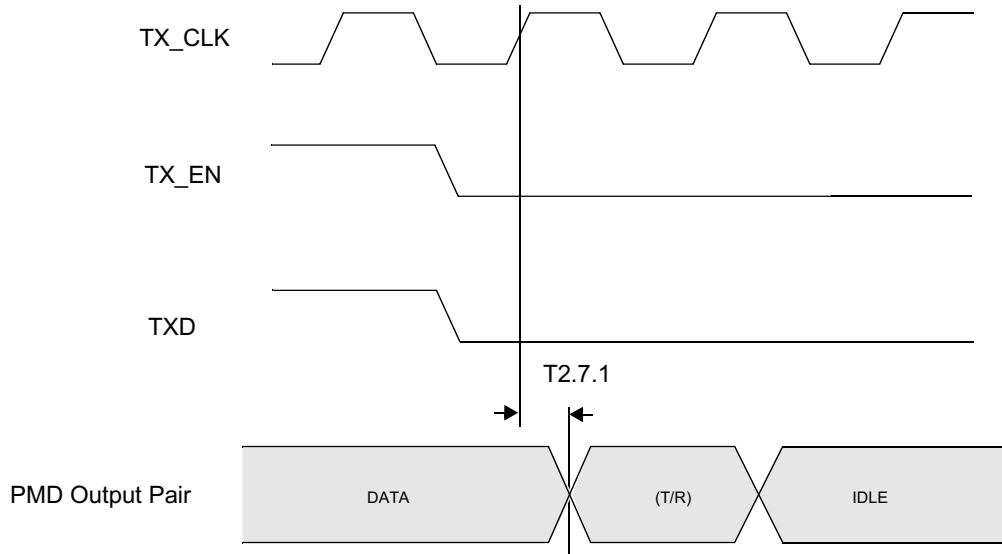

Figure 5-7. 100BASE-TX Transmit Packet Deassertion Timing

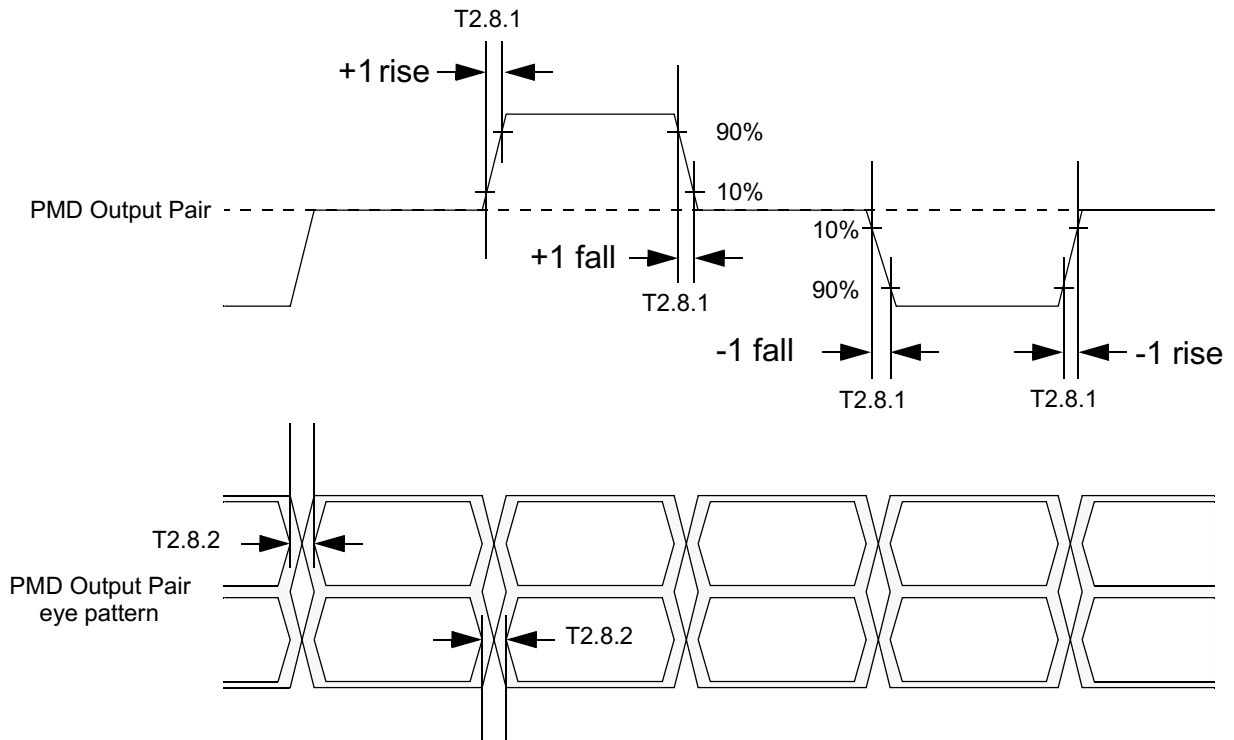

Figure 5-8. 100BASE-TX Transmit Timing ($t_{r/f}$ and Jitter)

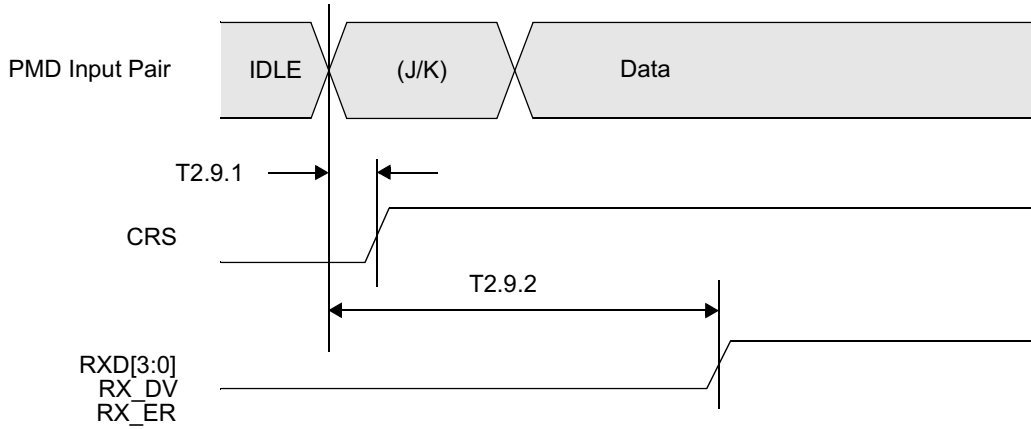

Figure 5-9. 100BASE-TX Receive Packet Latency Timing

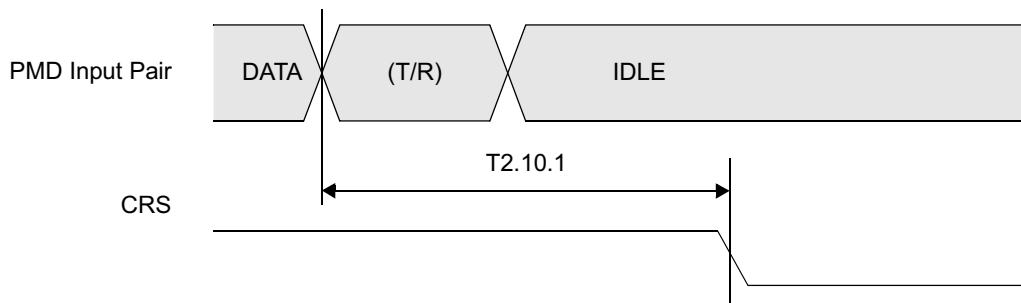

Figure 5-10. 100BASE-TX Receive Packet Deassertion Timing

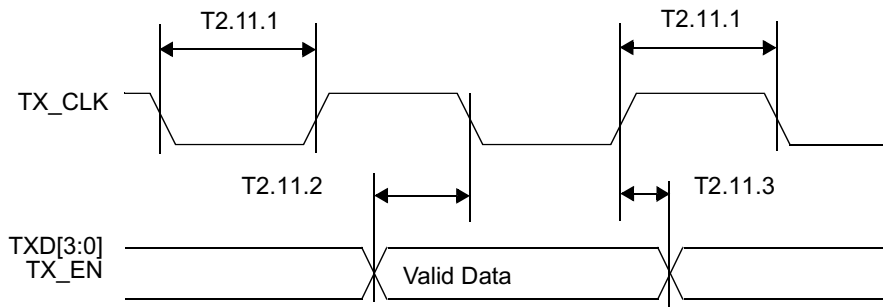

Figure 5-11. 10 Mb/s MII Transmit Timing

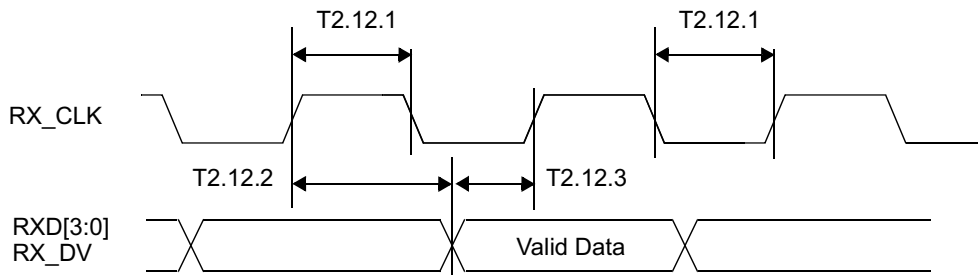

Figure 5-12. 10 Mb/s MII Receive Timing

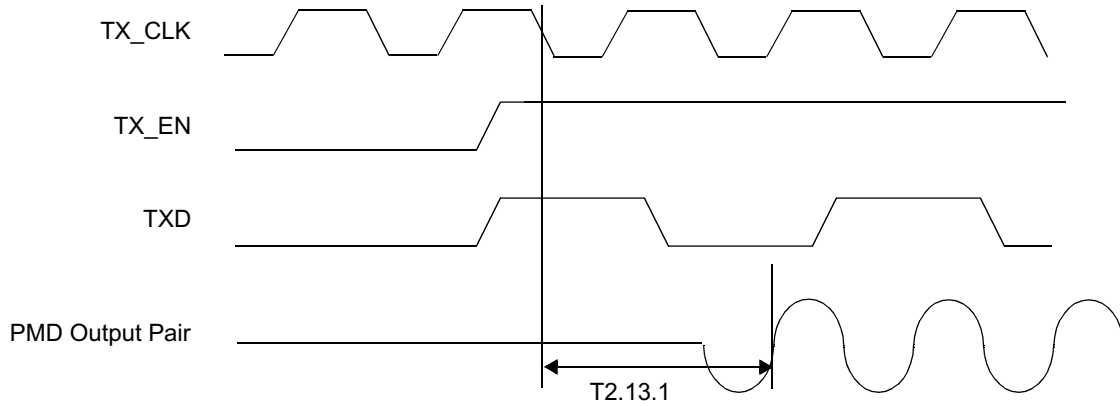

Figure 5-13. 10BASE-T Transmit Timing (Start of Packet)

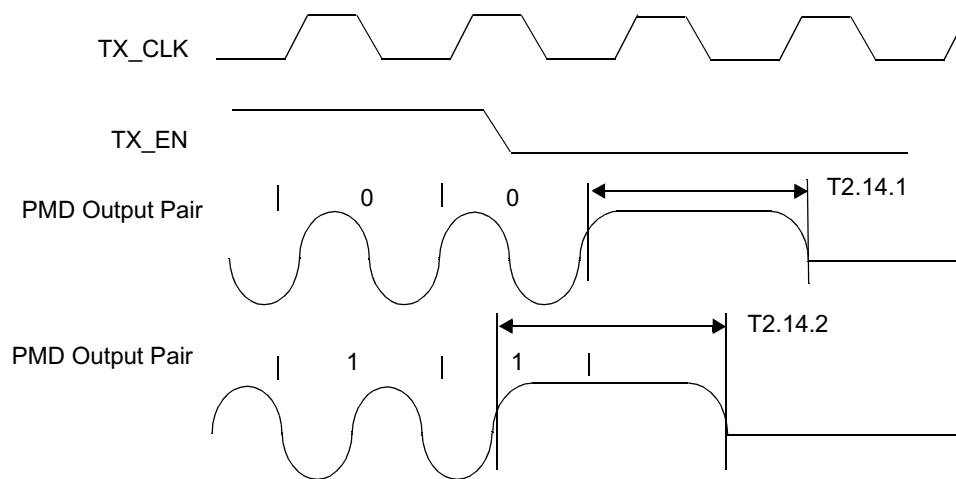

Figure 5-14. 10BASE-T Transmit Timing (End of Packet)

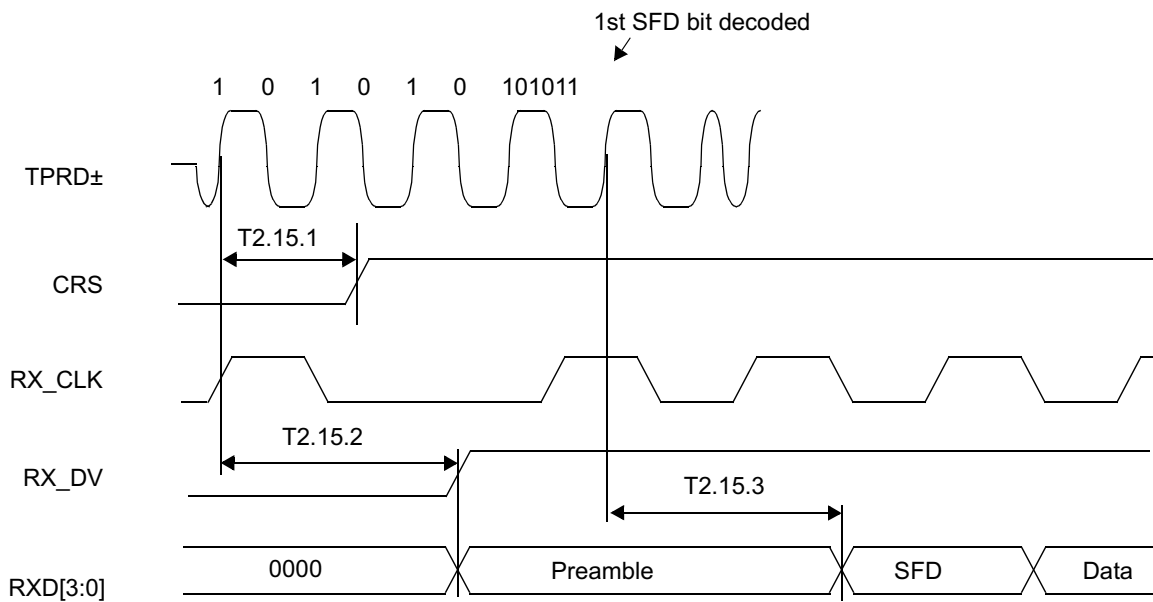

Figure 5-15. 10BASE-T Receive Timing (Start of Packet)

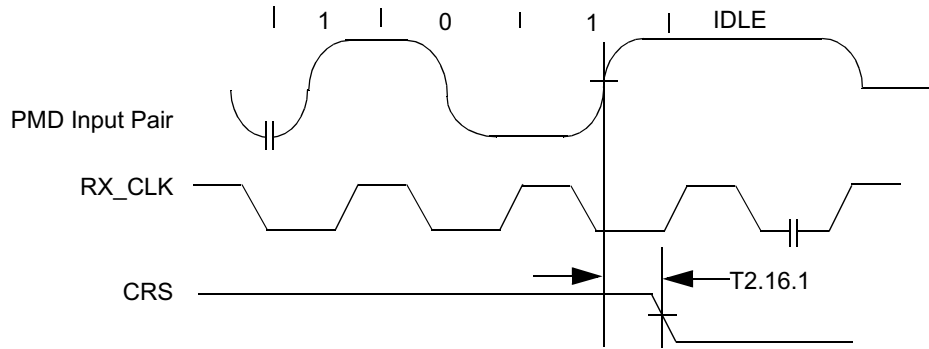

Figure 5-16. 10BASE-T Receive Timing (End of Packet)

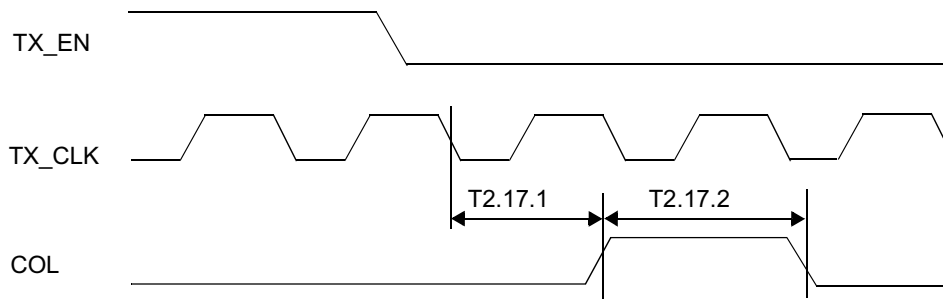

Figure 5-17. 10 Mb/s Heartbeat Timing

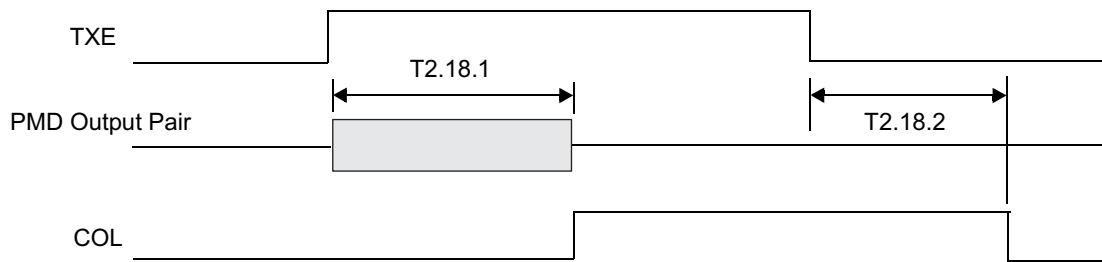

Figure 5-18. 10 Mb/s Jabber Timing

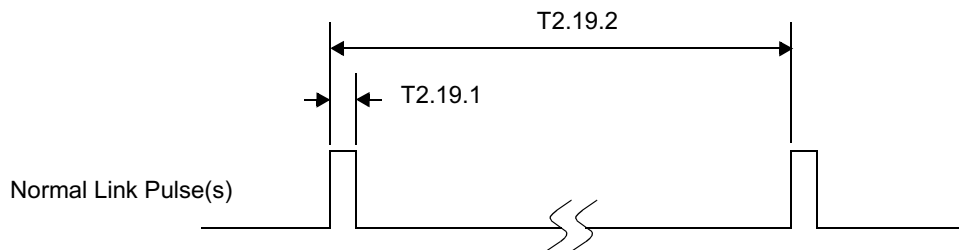

Figure 5-19. 10BASE-T Normal Link Pulse Timing

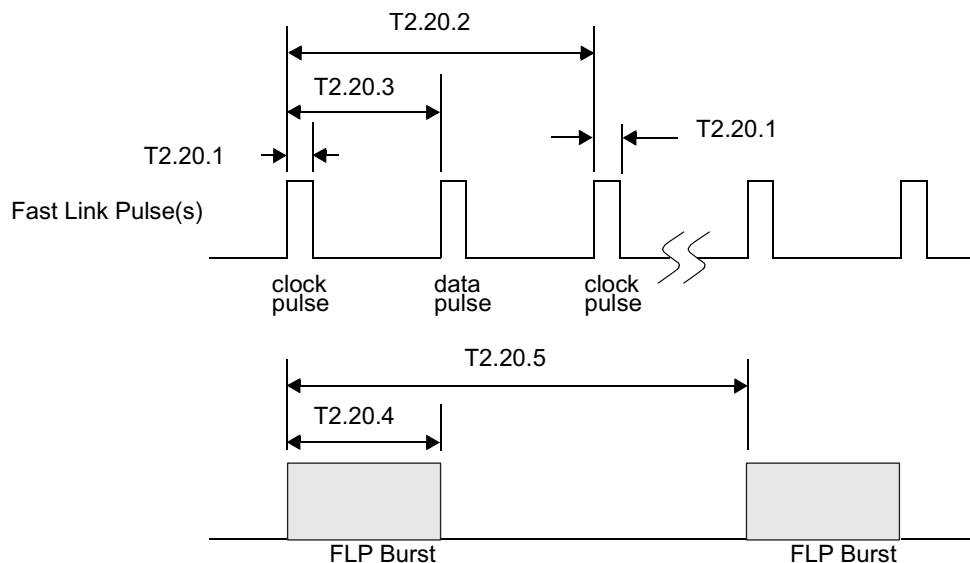

Figure 5-20. Auto-Negotiation Fast Link Pulse (FLP) Timing

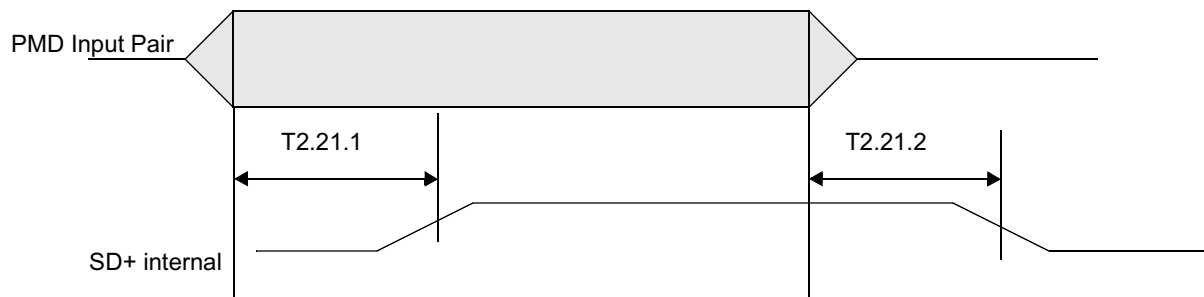

Figure 5-21. 100BASE-TX Signal Detect Timing

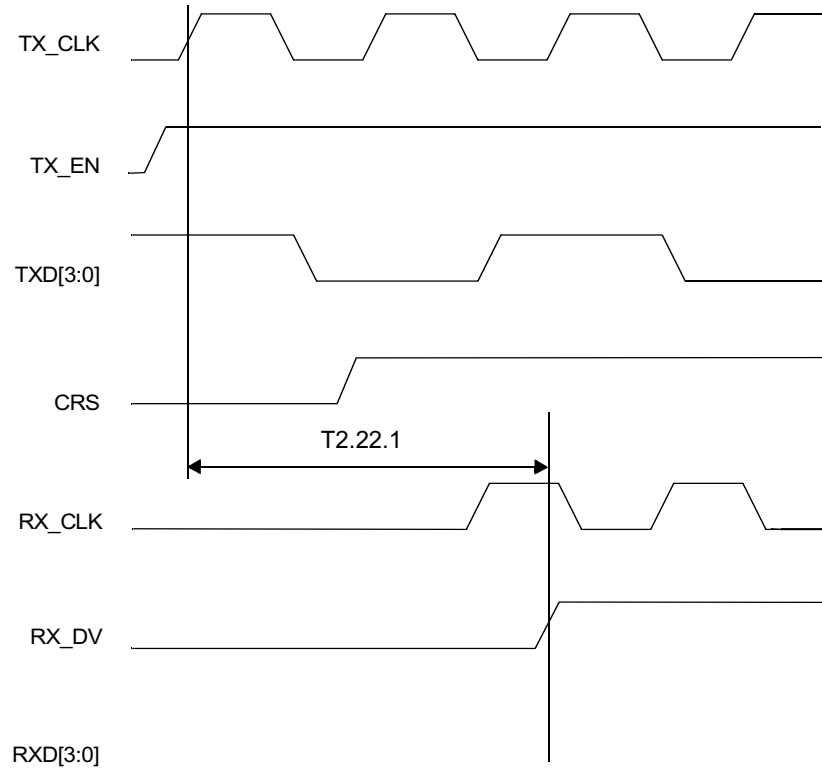

Figure 5-22. 100 Mb/s Internal Loopback Timing

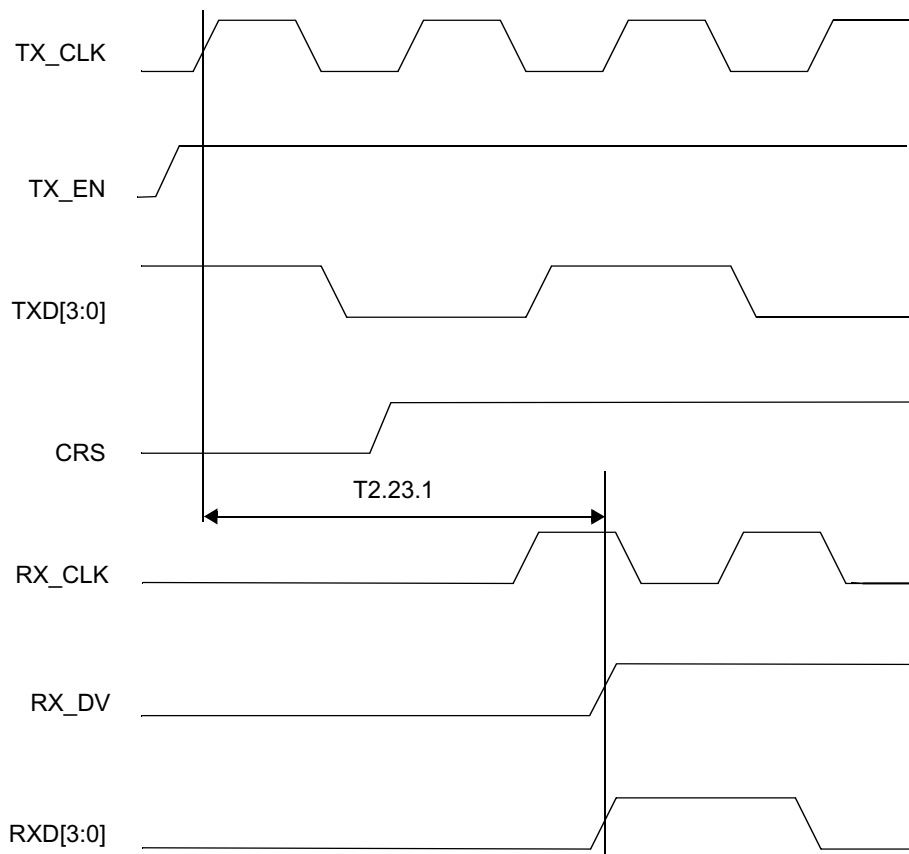

Figure 5-23. 10 Mb/s Internal Loopback Timing

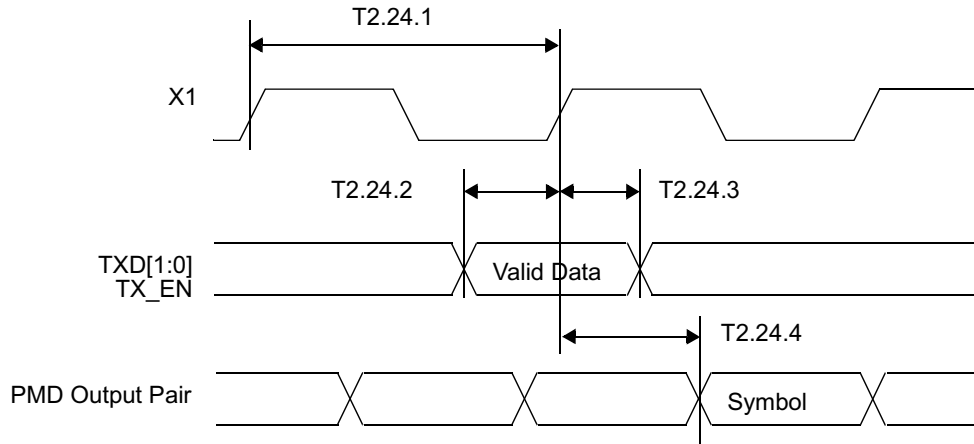

Figure 5-24. RMI Transmit Timing

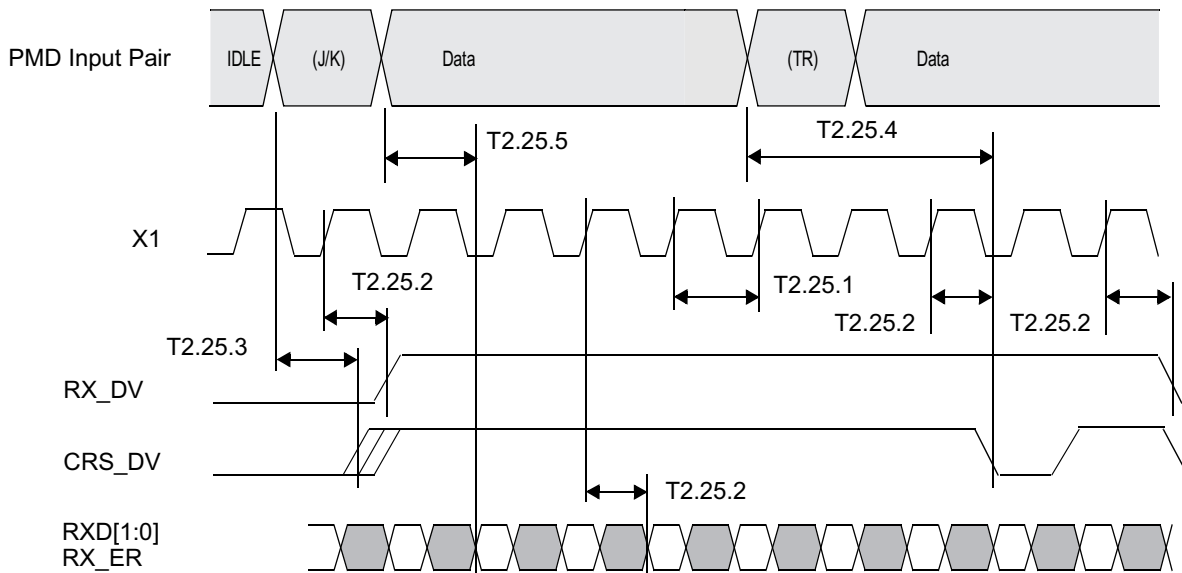

Figure 5-25. RMI Receive Timing

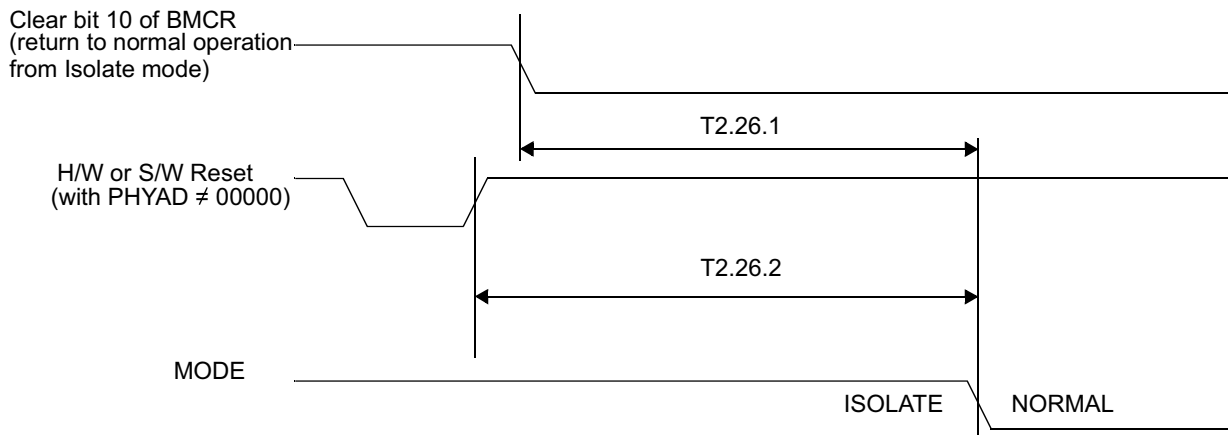

Figure 5-26. Isolation Timing

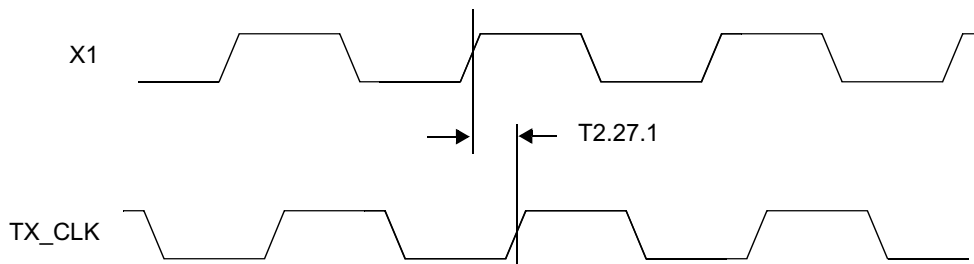

Figure 5-27. 100 Mb/s X1 to TX_CLK Timing

6 Detailed Description

6.1 Overview

The device is 10/100 Mbps Ethernet transceiver with an extended temperature range of -40°C to 105°C. The ability to perform over extreme temperatures makes this device ideal for demanding environments like automotive, transportation and industrial applications.

The device is AEC-Q100 Grade 2 certified. Its 3.3-V operating voltage and less than 270-mW typical power consumption makes this device suitable for low-power applications.

The device has Auto MDIX capability to select MDI or MDIX automatically. It supports Auto-Negotiation for selecting the highest performance mode of operation. This functionality can be turned off if a particular mode is to be forced.

The device supports both MII and RMI interface, thus being more flexible and increasing the number of compatible MPU. MII and RMI options can be selected using strap options or register control. The device operates with 25-MHz clock when in MII mode and requires a 50-MHz clock when in RMI mode.

6.2 Functional Block Diagram

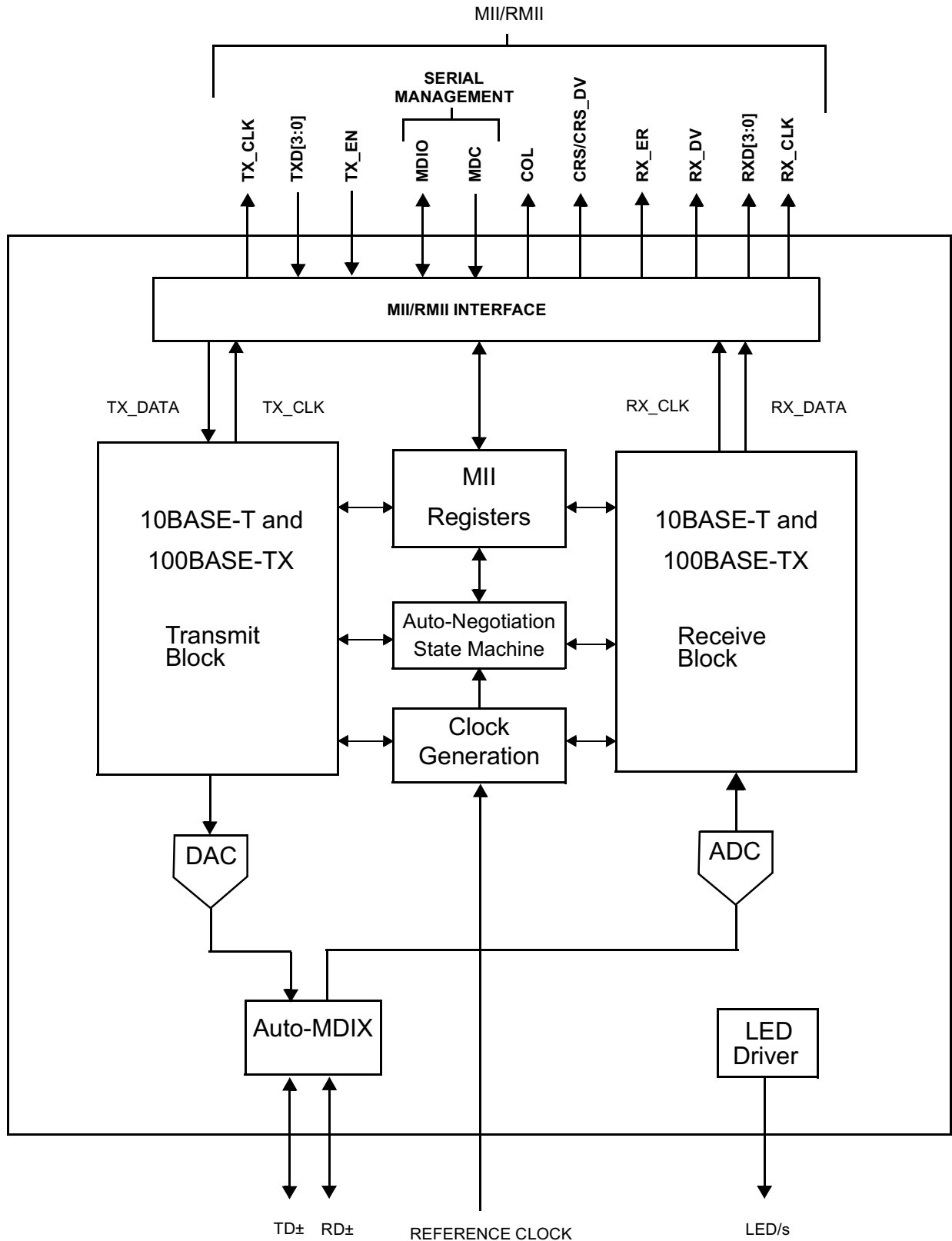

6.3 Feature Description

This section includes information on the various configurable features available with the DP83848x. The configurations features described below include:

- Auto-Negotiation
- Auto-MDIX
- LED Interface
- Internal Loopback
- BIST
- Energy Detect Mode

6.3.1 Auto-Negotiation

The Auto-Negotiation function provides a mechanism for exchanging configuration information between two ends of a link segment and automatically selecting the highest performance mode of operation supported by both devices. Fast Link Pulse (FLP) Bursts provide the signaling used to communicate Auto-Negotiation abilities between two devices at each end of a link segment. For further detail regarding Auto-Negotiation, refer to Clause 28 of the IEEE 802.3 specification. The DP83848x supports four different Ethernet protocols (10 Mb/s Half Duplex, 10 Mb/s Full Duplex, 100 Mb/s Half Duplex, and 100 Mb/s Full Duplex), so the inclusion of Auto-Negotiation ensures that the highest performance protocol will be selected based on the advertised ability of the Link Partner. In DP83848x, the Auto-Negotiation function can be controlled either by internal register access or by the use of AN0 and AN1 pins.

6.3.1.1 Auto-Negotiation Pin Control

The state of AN0 and AN1 pins determine the specific mode advertised by the device as given in [Table 6-1](#). The state of AN0 and AN1 pins, upon power up/reset, determines the state of bits [8:5] of the ANAR register.

The Auto-Negotiation function selected at power up or reset can be changed at any time by writing to the Basic Mode Control Register (BMCR) at address 0x00h.

Table 6-1. Auto-Negotiation Modes in DP83848x

AN1	AN0	ADVERTISED MODE
0	0	10BASE-T, Half/Full-Duplex
0	1	100BASE-TX, Half/Full-Duplex
1	0	10BASE-T, Half-Duplex 100BASE-TX, Half-Duplex
1	1	10BASE-T, Half/Full-Duplex 100BASE-TX, Half/Full-Duplex

6.3.1.2 Auto-Negotiation Register Control

When Auto-Negotiation is enabled, the DP83848x transmits the abilities programmed into the Auto-Negotiation Advertisement register (ANAR) at address 04h through FLP Bursts. Any combination of 10 Mb/s, 100 Mb/s, Half-Duplex, and Full Duplex modes may be selected.

Auto-Negotiation Priority Resolution:

1. 100BASE-TX Full Duplex (Highest Priority)
2. 100BASE-TX Half Duplex
3. 10BASE-T Full Duplex
4. 10BASE-T Half Duplex (Lowest Priority)

The Basic Mode Control Register (BMCR) at address 00h provides control for enabling, disabling, and restarting the Auto-Negotiation process. When Auto-Negotiation is disabled, the Speed Selection bit in the BMCR controls switching between 10 Mb/s or 100 Mb/s operation, and the Duplex Mode bit controls switching between full duplex operation and half duplex operation. The Speed Selection and Duplex Mode bits have no effect on the mode of operation when the Auto-Negotiation Enable bit is set.

The Link Speed can be examined through the PHY Status Register (PHYSTS) at address 10h after a Link is achieved.

The Basic Mode Status Register (BMSR) indicates the set of available abilities for technology types, Auto-Negotiation ability, and Extended Register Capability. These bits are permanently set to indicate the full functionality of the DP83848x (only the 100BASE-T4 bit is not set because the DP83848x does not support that function).

The BMSR also provides status on:

- Completion of Auto-Negotiation
- Occurrence of a remote fault as advertised by the Link Partner
- Establishment of a valid link
- Support for Management Frame Preamble suppression

The Auto-Negotiation Advertisement Register (ANAR) indicates the Auto-Negotiation abilities to be advertised by the DP83848x. All available abilities are transmitted by default, but any ability can be suppressed by writing to the ANAR. Updating the ANAR to suppress an ability is one way for a management agent to change (restrict) the technology that is used.

The Auto-Negotiation Link Partner Ability Register (ANLPAR) at address 05h is used to receive the base link code word as well as all next page code words during the negotiation. Furthermore, the ANLPAR will be updated to either 0081h or 0021h for parallel detection to either 100 Mb/s or 10 Mb/s respectively.

The Auto-Negotiation Expansion Register (ANER) indicates additional Auto-Negotiation status. The ANER provides status on:

- Occurrence of a Parallel Detect Fault
- Next Page function support by the Link Partner
- Next page support function by DP83848x
- Reception of the current page that is exchanged by AutoNegotiation
- Auto-Negotiation support by the Link Partner

6.3.1.3 Auto-Negotiation Parallel Detection

The DP83848x supports the Parallel Detection function as defined in the IEEE 802.3 specification. Parallel Detection requires both the 10 Mb/s and 100 Mb/s receivers to monitor the receive signal and report link status to the Auto-Negotiation function. Auto-Negotiation uses this information to configure the correct technology in the event that the Link Partner does not support Auto-Negotiation but is transmitting link signals that the 100BASE-TX or 10BASE-T PMAs recognize as valid link signals.

If the DP83848x completes Auto-Negotiation as a result of Parallel Detection, bit 5 or bit 7 within the ANLPAR register will be set to reflect the mode of operation present in the Link Partner. Note that bits 4:0 of the ANLPAR will also be set to 00001 based on a successful parallel detection to indicate a valid 802.3 selector field. Software may determine that negotiation completed through Parallel Detection by reading a zero in the Link Partner Auto-Negotiation Able bit once the Auto-Negotiation Complete bit is set. If configured for parallel detect mode and any condition other than a single good link occurs then the parallel detect fault bit will be set.

6.3.1.4 Auto-Negotiation Restart

Once Auto-Negotiation has completed, it may be restarted at any time by setting bit 9 (Restart Auto-Negotiation) of the BMCR to one. If the mode configured by a successful Auto-Negotiation loses a valid link, then the Auto-Negotiation process will resume and attempt to determine the configuration for the link. This function ensures that a valid configuration is maintained if the cable becomes disconnected.

A renegotiation request from any entity, such as a management agent, will cause the DP83848x to halt any transmit data and link pulse activity until the `break_link_timer` expires (approximately 1500 ms). Consequently, the Link Partner will go into link fail and normal Auto-Negotiation resumes. The DP83848x will resume Auto-Negotiation after the `break_link_timer` has expired by issuing FLP (Fast Link Pulse) bursts.

6.3.1.5 Auto-Negotiation Complete Time

Parallel detection and Auto-Negotiation take approximately 2-3 seconds to complete. In addition, Auto-Negotiation with next page should take approximately 2-3 seconds to complete, depending on the number of next pages sent.

Refer to Clause 28 of the IEEE 802.3 standard for a full description of the individual timers related to Auto-Negotiation.

6.3.2 Auto-MDIX

When enabled, this function uses Auto-Negotiation to determine the proper configuration for transmission and reception of data and subsequently selects the appropriate MDI pair for MDI/MDIX operation. The function uses a random seed to control switching of the crossover circuitry. This implementation complies with the corresponding IEEE 802.3 Auto-Negotiation and Crossover Specifications.

Auto-MDIX is enabled by default and can be configured through strap or through PHYCR (0x19h) register, bits [15:14]. Neither Auto-Negotiation nor Auto-MDIX is required to be enabled in forcing crossover of the MDI pairs. Forced crossover can be achieved through the `FORCE_MDIX` bit, bit 14 of PHYCR (0x19h) register.

NOTE

Auto-MDIX will not work in a forced mode of operation.

6.3.3 LED Interface

The DP83848J/K supports configurable Light Emitting Diode (LED) pins for configuring the link and speed. The DP83848H/M/T supports a configurable Light Emitting Diode (LED) pin for configuring the link. Additional configuration of `LED_LINK` can be achieved using bit [5] of the PHY Control Register (PHYCR) at register address 19h.

See [Table 6-2](#) for LED Mode selection of DP83848x.

Table 6-2. LED Mode Select for DP83848x

MODE	LED_CFG[0] (bit 5) or (pin 33)	LED_LINK	LED_SPEED ⁽¹⁾
1	1	ON for Good Link OFF for No Link	ON in 100Mb/s OFF in 10Mb/s
2	0	ON for Good Link BLINK for Activity	ON in 100Mb/s OFF in 10Mb/s

(1) `LED_SPEED` only supported for DP83848J/K.

The LED_LINK pin in Mode 1 indicates the link status of the port. In 100BASE-T mode, link is established as a result of input receive amplitude compliant with the TPPMD specifications which will result in internal generation of signal detect. A 10 Mb/s Link is established as a result of the reception of at least seven consecutive normal Link Pulses or the reception of a valid 10BASE-T packet. This will cause the assertion of LED_LINK. LED_LINK will deassert in accordance with the Link Loss Timer as specified in the IEEE 802.3 specification.

The LED_LINK pin in Mode 1 will be OFF when no LINK is present.

The LED_LINK pin in Mode 2 will be ON to indicate Link is good and BLINK to indicate activity is present on either transmit or receive activity.

The LED_SPEED pin in DP83848J/K indicates 10 or 100 Mb/s data rate of the port. The standard CMOS driver goes high when operating in 100Mb/s operation. The functionality of this LED is independent of the mode selected.

Because these LED pins are also used as strap options, the polarity of the LED is dependent on whether the pin is pulled up or down.

6.3.3.1 LED

Because the Auto-Negotiation strap options share the LED output pins, the external components required for strapping and LED usage must be considered in order to avoid contention.

Specifically, when the LED output is used to drive the LED directly, the active state of the output driver is dependent on the logic level sampled by the AN input upon power up/reset. For example, if the AN input is resistively pulled low then the corresponding output will be configured as an active high driver. Conversely, if the AN input is resistively pulled high, then the corresponding output will be configured as an active low driver.

Refer to [Figure 6-1](#) for an example of AN connection to external components. In this example, the AN strapping results in Auto-Negotiation with 10BASE-T Half-Duplex , 100BASE-TX, Half-Duplex advertised.

The adaptive nature of the LED output helps to simplify potential implementation issues of this dual-purpose pin.

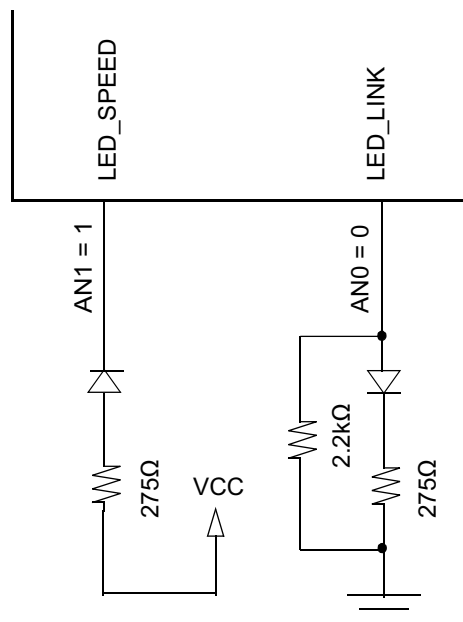

Note: LED_SPEED only supported for DP83848J/K.

Figure 6-1. AN Strapping and LED Loading Example

6.3.3.2 LED Direct Control

The DP83848x provides another option to directly control the LED outputs through the LED Direct Control Register (LEDCR), address 18h. The register does not provide read access to the LED.

6.3.4 Internal Loopback

The DP83848x includes a Loopback Test mode for facilitating system diagnostics. The Loopback mode is selected through bit 14 (Loopback) of the Basic Mode Control Register (BMCR). Writing 1 to this bit enables MII transmit data to be routed to the MII receive outputs. Loopback status may be checked in bit 3 of the PHY Status Register (PHYSTS). While in Loopback mode the data will not be transmitted onto the media. *To ensure that the desired operating mode is maintained, Auto-Negotiation should be disabled before selecting the Loopback mode.*

6.3.5 BIST

The DP83848x incorporates an internal Built-in Self Test (BIST) circuit to accommodate in-circuit testing or diagnostics. The BIST circuit can be used to test the integrity of the transmit and receive data paths. BIST testing can be performed with the part in the internal loopback mode or externally looped back using a loopback cable fixture.

The BIST is implemented with independent transmit and receive paths, with the transmit block generating a continuous stream of a pseudo random sequence. The user can select a 9 bit or 15 bit pseudo random sequence from the PSR_15 bit in the PHY Control Register (PHYCR). The received data is compared to the generated pseudo-random data by the BIST Linear Feedback Shift Register (LFSR) to determine the BIST pass/fail status.

The pass/fail status of the BIST is stored in the BIST status bit in the PHYCR register. The status bit defaults to 0 (BIST fail) and will transition on a successful comparison. If an error (mis-compare) occurs, the status bit is latched and is cleared upon a subsequent write to the Start/Stop bit.

For transmit VOD testing, the Packet BIST Continuous Mode can be used to allow continuous data transmission, setting BIST_CONT_MODE, bit 5, of CDCTRL1 (0x1Bh).

The number of BIST errors can be monitored through the BIST Error Count in the CDCTRL1 (0x1Bh), bits [15:8].

6.3.6 Energy Detect Mode

When Energy Detect is enabled and there is no activity on the cable, the DP83848x will remain in a low power mode while monitoring the transmission line. Activity on the line will cause the DP83848x to go through a normal power-up sequence. Regardless of cable activity, the DP83848x will occasionally wake up the transmitter to put ED pulses on the line, but will otherwise draw as little power as possible. Energy detect functionality is controlled through register Energy Detect Control (EDCR), address 0x1Dh.

6.4 Device Functional Modes

The DP83848x supports two modes of operation using the MII interface pins. The options are defined in the following sections and include:

- MII Mode
- RMII Mode

The modes of operation can be selected by strap options or register control. For RMII mode, it is required to use the strap option, because it requires a 50-MHz clock instead of the normal 25 MHz.

In the each of these modes, the IEEE 802.3 serial management interface is operational for device configuration and status. The serial management interface of the MII allows for the configuration and control of multiple PHY devices, gathering of status, error information, and the determination of the type and capabilities of the attached PHY(s).

6.4.1 MII Interface

The DP83848x incorporates the Media Independent Interface (MII) as specified in Clause 22 of the IEEE 802.3 standard. This interface may be used to connect PHY devices to a MAC in 10/100 Mb/s systems. This section describes the nibble wide MII data interface.

The nibble wide MII data interface consists of a receive bus and a transmit bus each with control signals to facilitate data transfer between the PHY and the upper layer (MAC).

6.4.1.1 Nibble-wide MII Data Interface

Clause 22 of the IEEE 802.3 specification defines the Media Independent Interface. This interface includes a dedicated receive bus and a dedicated transmit bus. These two data buses, along with various control and status signals, allow for the simultaneous exchange of data between the DP83848x and the upper layer agent (MAC).

The receive interface consists of a nibble wide data bus RXD[3:0], a receive error signal RX_ER, a receive data valid flag RX_DV, and a receive clock RX_CLK for synchronous transfer of the data. The receive clock operates at either 2.5 MHz to support 10 Mb/s operation modes or at 25 MHz to support 100 Mb/s operational modes.

The transmit interface consists of a nibble wide data bus TXD[3:0], a transmit enable control signal TX_EN, and a transmit clock TX_CLK which runs at either 2.5 MHz or 25 MHz.

Additionally, the MII includes the carrier sense signal CRS, as well as a collision detect signal COL. The CRS signal asserts to indicate the reception of data from the network or as a function of transmit data in Half Duplex mode. The COL signal asserts as an indication of a collision which can occur during half-duplex operation when both a transmit and receive operation occur simultaneously.

6.4.1.2 Collision Detect

For Half Duplex, a 10BASE-T or 100BASE-TX collision is detected when the receive and transmit channels are active simultaneously. Collisions are reported by the COL signal on the MII.

If the DP83848x is transmitting in 10 Mb/s mode when a collision is detected, the collision is not reported until seven bits have been received while in the collision state. This prevents a collision being reported incorrectly due to noise on the network. The COL signal remains set for the duration of the collision.

If a collision occurs during a receive operation, it is immediately reported by the COL signal.

When heartbeat is enabled (only applicable to 10 Mb/s operation), approximately 1 μ s after the transmission of each packet, a Signal Quality Error (SQE) signal of approximately 10 bit times is generated (internally) to indicate successful transmission. SQE is reported as a pulse on the COL signal of the MII.

6.4.1.3 Carrier Sense

Carrier Sense (CRS) is asserted due to receive activity, once valid data is detected through the squelch function during 10 Mb/s operation. During 100 Mb/s operation, CRS is asserted when a valid link (SD) and two non-contiguous zeros are detected on the line.

For 10 or 100 Mb/s Half Duplex operation, CRS is asserted during either packet transmission or reception.

For 10 or 100 Mb/s Full Duplex operation, CRS is asserted only due to receive activity.

CRS is deasserted following an end of packet.

6.4.2 Reduced MII Interface

The DP83848x incorporates the Reduced Media Independent Interface (RMII) as specified in the RMII specification (revision 1.2) from the RMII Consortium. This interface may be used to connect PHY devices to a MAC in 10/100 Mb/s systems using a reduced number of pins. In this mode, data is transferred 2-bits at a time using the 50-MHz RMII_REF clock for both transmit and receive. The following pins are used in RMII mode:

- TX_EN
- TXD[1:0]
- RX_ER (optional for Mac)
- CRS_DV
- RXD[1:0]
- X1 (RMII Reference clock is 50 MHz)

In addition, the RMII mode supplies an RX_DV signal which allows for a simpler method of recovering receive data without having to separate RX_DV from the CRS_DV indication. This is especially useful for systems which do not require CRS, such as systems that only support full duplex operation. This signal is also useful for diagnostic testing where it may be desirable to loop Receive RMII data directly to the transmitter.

Because the reference clock operates at 10 times the data rate for 10 Mb/s operation, transmit data is sampled every 10 clocks. Likewise, receive data will be generated every 10th clock so that an attached device can sample the data every 10 clocks.

RMII mode requires a 50-MHz oscillator be connected to the device X1 pin. A 50-MHz crystal is not supported.

To tolerate potential frequency differences between the 50-MHz reference clock and the recovered receive clock, the receive RMII function includes a programmable elasticity buffer. The elasticity buffer is programmable to minimize propagation delay based on expected packet size and clock accuracy. This allows for supporting a range of packet sizes including jumbo frames.

The elasticity buffer will force Frame Check Sequence errors for packets which overrun or underrun the FIFO. Underrun and Overrun conditions can be reported in the RMII and Bypass Register (RBR). The following table indicates how to program the elasticity buffer FIFO (in 4-bit increments) based on expected max packet size and clock accuracy. It assumes both clocks (RMII Reference clock and far-end Transmitter clock) have the same accuracy.

Table 6-3. Supported Packet Sizes at ± 50 ppm and ± 100 ppm for Each Clock

START THRESHOLD RBR[1:0]	LATENCY TOLERANCE	RECOMMENDED PACKET SIZE at ± 50 ppm	RECOMMENDED PACKET SIZE at ± 100 ppm
1 (4-bits)	2 bits	2400 bytes	1200 bytes
2 (8-bits)	6 bits	7200 bytes	3600 bytes
3 (12-bits)	10 bits	12000 bytes	6000 bytes
0 (16-bits)	14 bits	16800 bytes	8400 bytes

6.4.3 802.3 MII Serial Management Interface

6.4.3.1 Serial Management Register Access

The serial management MII specification defines a set of thirty-two 16-bit status and control registers that are accessible through the management interface pins MDC and MDIO. The DP83848x implements all the required MII registers as well as several optional registers. These registers are fully described in [Section 6.6](#). A description of the serial management access protocol follows.

6.4.3.2 Serial Management Access Protocol

The serial control interface consists of two pins, Management Data Clock (MDC) and Management Data Input/Output (MDIO). MDC has a maximum clock rate of 25 MHz and no minimum rate. The MDIO line is bi-directional and may be shared by up to 32 devices. The MDIO frame format is shown below in [Table 6-4](#).

The MDIO pin requires a pullup resistor (1.5 kΩ) which, during IDLE and turnaround, will pull MDIO high. In order to initialize the MDIO interface, the station management entity sends a sequence of 32 contiguous logic ones on MDIO to provide the DP83848x with a sequence that can be used to establish synchronization. This preamble may be generated either by driving MDIO high for 32 consecutive MDC clock cycles, or by simply allowing the MDIO pullup resistor to pull the MDIO pin high during which time 32 MDC clock cycles are provided. In addition, 32 MDC clock cycles should be used to re-sync the device if an invalid start, opcode, or turnaround bit is detected.

The DP83848x waits until it has received this preamble sequence before responding to any other transaction. Once the DP83848x serial management port has been initialized no further preamble sequencing is required until after a power on/reset, invalid Start, invalid Opcode, or invalid turnaround bit has occurred.

The Start code is indicated by a <01> pattern. This assures the MDIO line transitions from the default idle line state.

Turnaround is defined as an idle bit time inserted between the Register Address field and the Data field. To avoid contention during a read transaction, no device shall actively drive the MDIO signal during the first bit of Turnaround. The addressed DP83848x drives the MDIO with a zero for the second bit of turnaround and follows this with the required data. [Figure 6-2](#) shows the timing relationship between MDC and the MDIO as driven/received by the Station (STA) and the DP83848x (PHY) for a typical register read access.

For write transactions, the station management entity writes data to the addressed DP83848x thus eliminating the requirement for MDIO Turnaround. The Turnaround time is filled by the management entity by inserting <10>. [Figure 6-3](#) shows the timing relationship for a typical MII register write access.

Table 6-4. Typical MDIO Frame Format

MII MANAGEMENT SERIAL PROTOCOL	<idle><start><op code><device addr><reg addr><turnaround><data><idle>
Read Operation	<idle><01><10><AAAA><RRRR><Z0><xxxx xxxx xxxx xxxx><idle>
Write Operation	<idle><01><01><AAAA><RRRR><10><xxxx xxxx xxxx xxxx><idle>

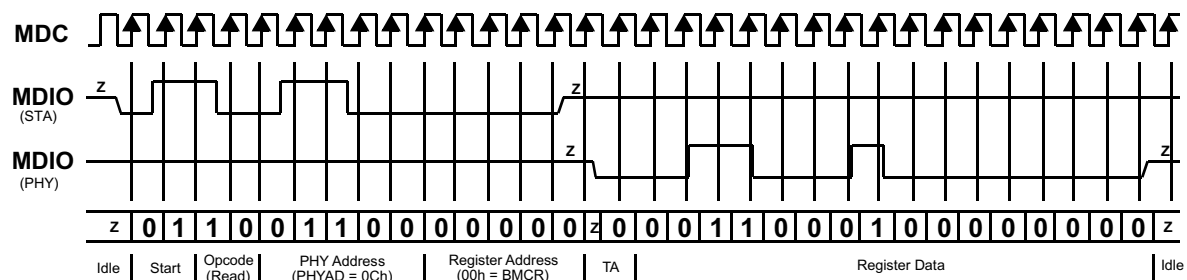

Figure 6-2. Typical MDC/MDIO Read Operation

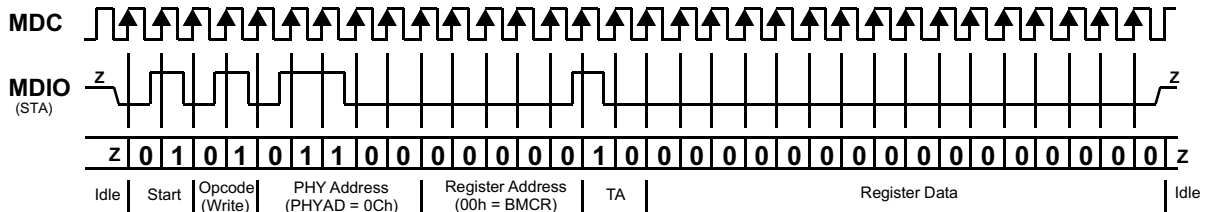

Figure 6-3. Typical MDC/MDIO Write Operation

6.4.3.3 Serial Management Preamble Suppression

The DP83848x supports a Preamble Suppression mode as indicated by a one in bit 6 of the Basic Mode Status Register (BMSR, address 01h.) If the station management entity (that is, MAC or other management controller) determines that all PHYs in the system support Preamble Suppression by returning a one in this bit, then the station management entity need not generate preamble for each management transaction.

The DP83848x requires a single initialization sequence of 32 bits of preamble following hardware/software reset. This requirement is generally met by the mandatory pullup resistor on MDIO in conjunction with a continuous MDC, or the management access made to determine whether Preamble Suppression is supported.

While the DP83848x requires an initial preamble sequence of 32 bits for management initialization, it does not require a full 32-bit sequence between each subsequent transaction. A *minimum of one idle bit between management transactions is required* as specified in the IEEE 802.3 specification.

6.4.4 PHY Address

The 5 PHY address inputs pins are shared with the RXD[3:0] pins and COL pin as shown in Table 6-5.

Table 6-5. PHY Address Mapping

PIN #	PHYAD FUNCTION	RXD FUNCTION
35	PHYAD0	COL
36	PHYAD1	RXD_0
37	PHYAD2	RXD_1
38	PHYAD3	RXD_2
39	PHYAD4	RXD_3

The DP83848x can be set to respond to any of 32 possible PHY addresses through strap pins. The information is latched into the PHYCR register (address 19h, bits [4:0]) at device power up and hardware reset. The PHY Address pins are shared with the RXD and COL pins. Each DP83848x or port sharing an MDIO bus in a system must have a unique physical address.

The DP83848x supports PHY Address strapping values 0 (<00000>) through 31 (<11111>). Strapping PHY Address 0 puts the part into Isolate Mode. It should also be noted that selecting PHY Address 0 through an MDIO write to PHYCR will not put the device in Isolate Mode. See Section 6.4.4.1 for more information.

For further detail relating to the latch-in timing requirements of the PHY Address pins, as well as the other hardware configuration pins, refer to the Reset summary in Section 6.4.6.

Because the PHYAD[0] pin has weak internal pullup resistor and PHYAD[4:1] pins have weak internal pulldown resistors, the default setting for the PHY address is 00001 (01h).

Refer to Figure 6-4 for an example of a PHYAD connection to external components. In this example, the PHYAD strapping results in address 00011 (03h).

6.4.4.1 MII Isolate Mode

The DP83848x can be put into MII Isolate mode by writing to bit 10 of the BMCR register or by strapping in Physical Address 0. It should be noted that selecting Physical Address 0 through an MDIO write to PHYCR will not put the device in the MII isolate mode.

When in the MII isolate mode, the DP83848x does not respond to packet data present at TXD[3:0], TX_EN inputs and presents a high impedance on the TX_CLK, RX_CLK, RX_DV, RX_ER, RXD[3:0], COL, and CRS outputs. When in Isolate mode, the DP83848x will continue to respond to all management transactions.

While in Isolate mode, the PMD output pair will not transmit packet data but will continue to source 100BASE-TX scrambled idles or 10BASE-T normal link pulses.

The DP83848x can Auto-Negotiate or parallel detect to a specific technology depending on the receive signal at the PMD input pair. A valid link can be established for the receiver even when the DP83848x is in Isolate mode.

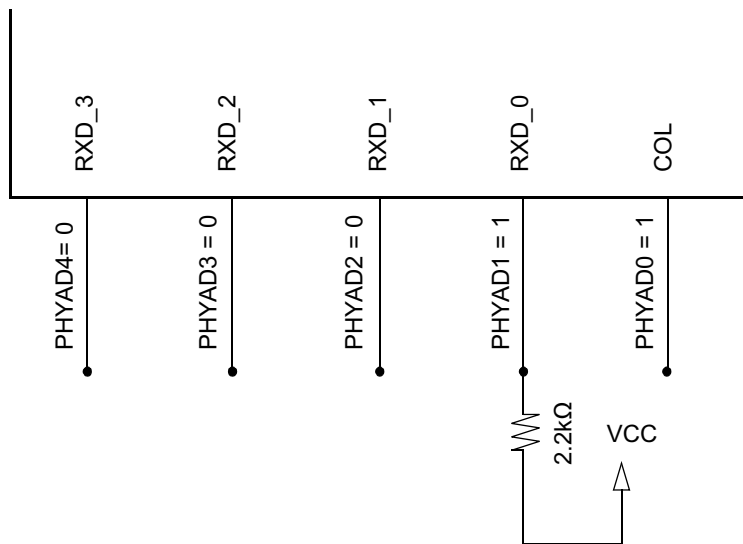

Figure 6-4. PHYAD Strapping Example

6.4.5 Half Duplex vs Full Duplex

The DP83848x supports both half and full duplex operation at both 10 Mb/s and 100 Mb/s speeds.

Half-duplex relies on the CSMA/CD protocol to handle collisions and network access. In Half-Duplex mode, CRS responds to both transmit and receive activity in order to maintain compliance with the IEEE 802.3 specification.

Because the DP83848x is designed to support simultaneous transmit and receive activity, it is capable of supporting full-duplex switched applications with a throughput of up to 200 Mb/s per port when operating in 100BASE-TX mode. Because the CSMA/CD protocol does not apply to full duplex operation, the DP83848x disables its own internal collision sensing and reporting functions and modifies the behavior of Carrier Sense (CRS) such that it indicates only receive activity. This allows a full-duplex capable MAC to operate properly.

All modes of operation (100BASE-TX and 10BASE-T) can run either half-duplex or full-duplex. Additionally, other than CRS and Collision reporting, all remaining MII signaling remains the same regardless of the selected duplex mode.

It is important to understand that while Auto-Negotiation with the use of Fast Link Pulse code words can interpret and configure to full-duplex operation, parallel detection can not recognize the difference between full and half-duplex from a fixed 10 Mb/s or 100 Mb/s link partner over twisted pair. As specified in the 802.3 specification, if a far-end link partner is configured to a forced full duplex 100BASE-TX ability, the parallel detection state machine in the partner would be unable to detect the full duplex capability of the far-end link partner. This link segment would negotiate to a half duplex 100BASE-TX configuration (same scenario for 10 Mb/s).

6.4.6 Reset Operation

The DP83848x includes an internal power-on reset (POR) function and does not need to be explicitly reset for normal operation after power up. If required during normal operation, the device can be reset by a hardware or software reset.

6.4.6.1 Hardware Reset

A hardware reset is accomplished by applying a low pulse (TTL level), with a duration of at least 1 μ s, to the RESET_N. This will reset the device such that all registers will be reinitialized to default values and the hardware configuration values will be re-latched into the device (similar to the power-up/reset operation).

6.4.6.2 Software Reset

A software reset is accomplished by setting the reset bit (bit 15) of the Basic Mode Control Register (BMCR). The period from the point in time when the reset bit is set to the point in time when software reset has concluded is approximately 1 μ s.

The software reset will reset the device such that all registers will be reinitialized to default values and the hardware configuration values will be re-latched into the device. Software driver code must wait 3 μ s following a software reset before allowing further serial MII operations.

6.4.7 Power Down

The device can be put in a Power Down mode by setting bit 11 (Power Down) in the Basic Mode Control Register, BMCR (0x00h).

6.5 Programming

6.5.1 Architecture

This section describes the operations within each transceiver module, 100BASE-TX and 10BASE-T. Each operation consists of several functional blocks and described in the following:

- 100BASE-TX Transmitter
- 100BASE-TX Receiver
- 10BASE-T Transceiver Module

6.5.1.1 100BASE-TX Transmitter

The 100BASE-TX transmitter consists of several functional blocks which convert synchronous 4-bit nibble data, as provided by the MII, to a scrambled MLT-3 125 Mb/s serial data stream. Because the 100BASE-TX TP-PMD is integrated, the differential output pins, PMD Output Pair, can be directly routed to the magnetics.

The Transmitter section consists of the following functional blocks:

- Code-group Encoder and Injection block
- Scrambler block (bypass option)
- NRZ to NRZI encoder block
- Binary to MLT-3 converter / Common Driver

The bypass option for the functional blocks within the 100BASE-TX transmitter provides flexibility for applications where data conversion is not always required. The DP83848x implements the 100BASE-TX transmit state machine diagram as specified in the IEEE 802.3 Standard, Clause 24.

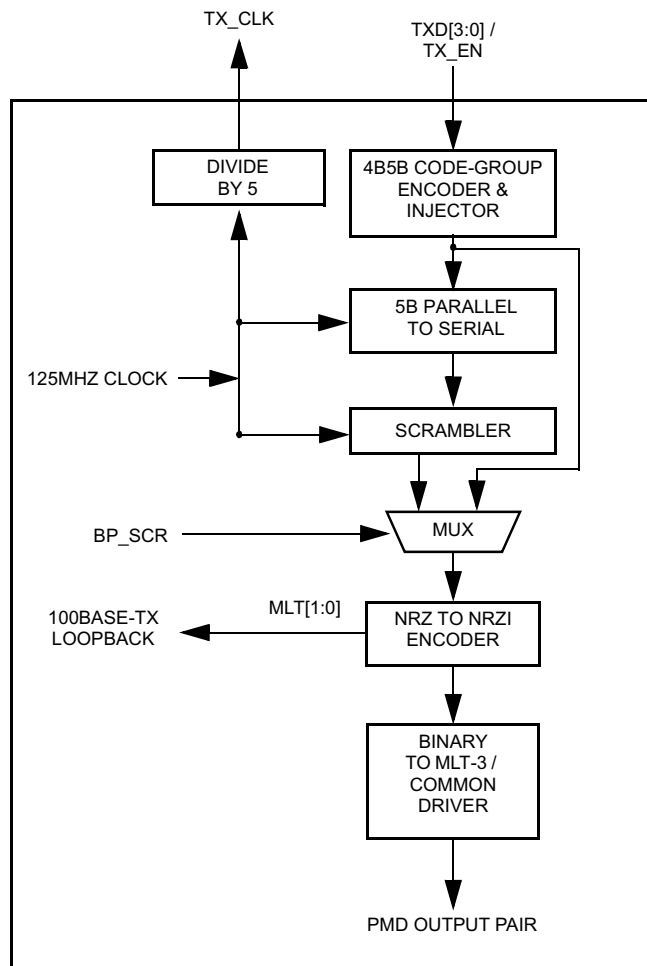

Figure 6-5. 100BASE-TX Transmit Block Diagram

Table 6-6. 4B5B Code-Group Encoding/Decoding

DATA CODES		
0	11110	0
1	1001	1
2	10100	10
3	10101	11
4	1010	100
5	1011	101
6	1110	110
7	1111	111
8	10010	1000
9	10011	1001
A	10110	1010
B	10111	1011
C	11010	1100
D	11011	1101
E	11100	1110
F	11101	1111
IDLE AND CONTROL CODES		
H	100	HALT code-group - Error code
I	11111	Inter-Packet IDLE - 0000 ⁽¹⁾
J	11000	First Start of Packet - 0101 ⁽¹⁾
K	10001	Second Start of Packet - 0101 ⁽¹⁾
T	1101	First End of Packet - 0000 ⁽¹⁾
R	111	Second End of Packet - 0000 ⁽¹⁾
INVALID CODES		
V	0	
V	1	
V	10	
V	11	
V	101	
V	110	
V	1000	
V	1100	

(1) Control code-groups I, J, K, T and R in data fields will be mapped as invalid codes, together with RX_ER asserted.

6.5.1.1.1 Code-Group Encoding and Injection

The code-group encoder converts 4-bit (4B) nibble data generated by the MAC into 5-bit (5B) code-groups for transmission. This conversion is required to allow control data to be combined with packet data code-groups. Refer to for 4B to 5B code-group mapping details. The code-group encoder substitutes the first 8-bits of the MAC preamble with a J/K code-group pair (11000 10001) upon transmission.

The code-group encoder continues to replace subsequent 4B preamble and data nibbles with corresponding 5B code-groups. At the end of the transmit packet, upon the deassertion of Transmit Enable signal from the MAC, the code-group encoder injects the T/R code-group pair (01101 00111) indicating the end of the frame.

After the T/R code-group pair, the code-group encoder continuously injects IDLEs into the transmit data stream until the next transmit packet is detected (reassertion of Transmit Enable).

6.5.1.1.2 Scrambler

The scrambler is required to control the radiated emissions at the media connector and on the twisted pair cable (for 100BASE-TX applications). By scrambling the data, the total energy launched onto the cable is randomly distributed over a wide frequency range. Without the scrambler, energy levels at the PMD and on the cable could peak beyond FCC limitations at frequencies related to repeating 5B sequences (that is, continuous transmission of IDLEs).

The scrambler is configured as a closed loop linear feed-back shift register (LFSR) with an 11-bit polynomial. The output of the closed loop LFSR is X-ORd with the serial NRZ data from the code-group encoder. The result is a scrambled data stream with sufficient randomization to decrease radiated emissions at certain frequencies by as much as 20 dB. The DP83848x uses the PHY_ID (pins PHYAD [4:0]) to set a unique seed value.

6.5.1.1.3 NRZ to NRZI Encoder

After the transmit data stream has been serialized and scrambled, the data must be NRZI encoded in order to comply with the TP-PMD standard for 100BASE-TX transmission over Category-5 Unshielded twisted pair cable.

6.5.1.1.4 Binary to MLT-3 Convertor

The Binary to MLT-3 conversion is accomplished by converting the serial binary data stream output from the NRZI encoder into two binary data streams with alternately phased logic one events. These two binary streams are then fed to the twisted pair output driver which converts the voltage to current and alternately drives either side of the transmit transformer primary winding, resulting in a MLT-3 signal.

The 100BASE-TX MLT-3 signal sourced by the PMD Output Pair common driver is slew rate controlled. This should be considered when selecting AC coupling magnetics to ensure TP-PMD Standard compliant transition times ($3 \text{ ns} < T_r < 5 \text{ ns}$).

The 100BASE-TX transmit TP-PMD function within the DP83848x is capable of sourcing only MLT-3 encoded data. Binary output from the PMD Output Pair is not possible in 100 Mb/s mode.

6.5.1.2 100BASE-TX Receiver

The 100BASE-TX receiver consists of several functional blocks which convert the scrambled MLT-3 125 Mb/s serial data stream to synchronous 4-bit nibble data that is provided to the MII. Because the 100BASE-TX TP-PMD is integrated, the differential input pins, RD \pm , can be directly routed from the AC coupling magnetics.

See [Figure 6-6](#) for a block diagram of the 100BASE-TX receive function. This provides an overview of each functional block within the 100BASE-TX receive section.

The Receive section consists of the following functional blocks:

- Analog Front End
- Digital Signal Processor
- Signal Detect
- MLT-3 to Binary Decoder
- NRZI to NRZ Decoder
- Serial to Parallel
- Descrambler
- Code Group Alignment
- 4B/5B Decoder
- Link Integrity Monitor
- Bad SSD Detection

6.5.1.2.1 Analog Front End

In addition to the Digital Equalization and Gain Control, the DP83848x includes Analog Equalization and Gain Control in the Analog Front End. The Analog Equalization reduces the amount of Digital Equalization required in the DSP.

6.5.1.2.2 Digital Signal Processor

The Digital Signal Processor includes Adaptive Equalization with Gain Control and Base Line Wander Compensation.

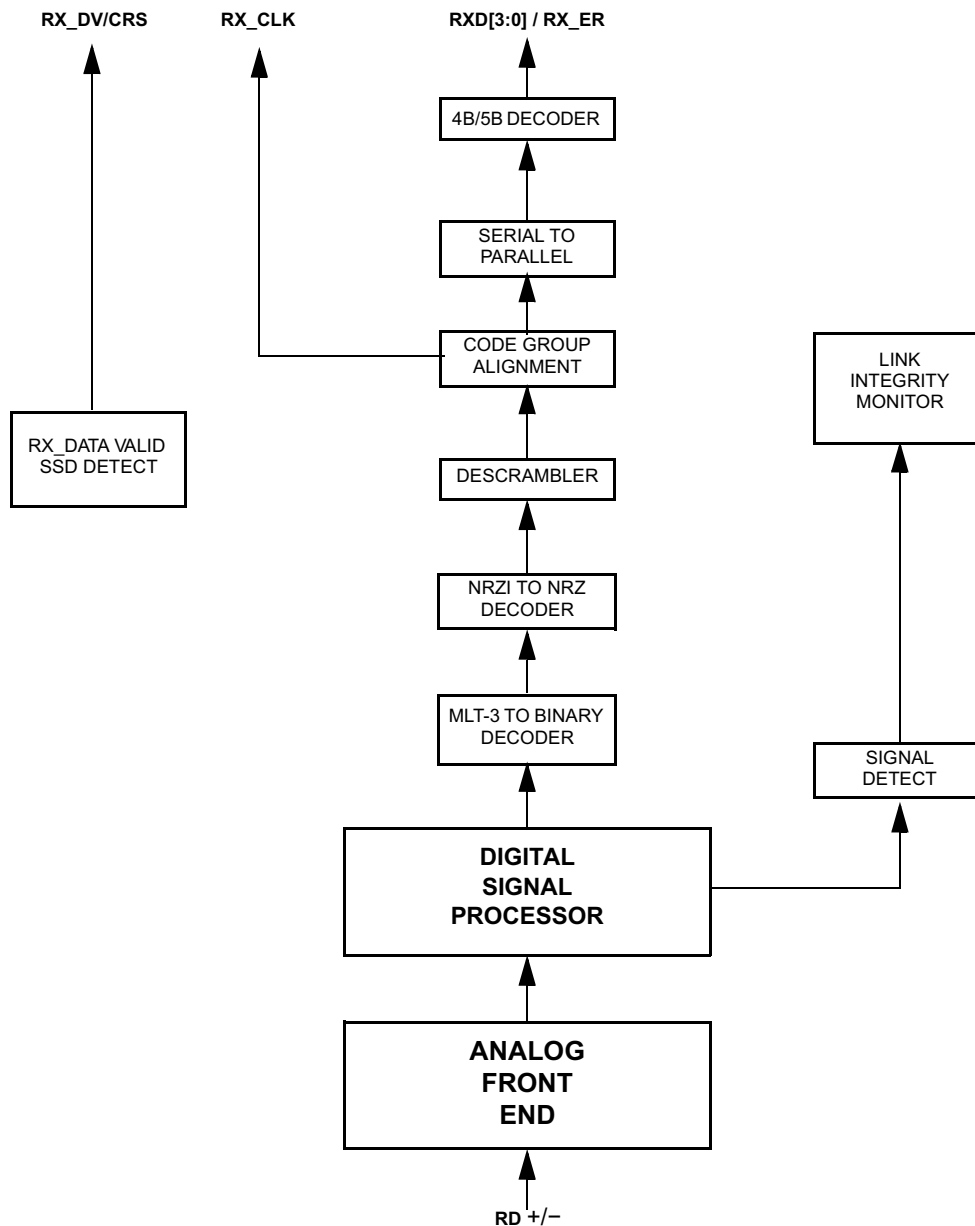

Figure 6-6. 100BASE-TX Receive Block Diagram

6.5.1.2.3 Digital Adaptive Equalization and Gain Control

When transmitting data at high speeds over copper twisted pair cable, frequency dependent attenuation becomes a concern. In high-speed twisted pair signaling, the frequency content of the transmitted signal can vary greatly during normal operation based primarily on the randomness of the scrambled data stream. This variation in signal attenuation caused by frequency variations must be compensated to ensure the integrity of the transmission.

In order to ensure quality transmission when employing MLT-3 encoding, the compensation must be able to adapt to various cable lengths and cable types depending on the installed environment. The selection of long cable lengths for a given implementation, requires significant compensation which will over-compensate for shorter, less attenuating lengths. Conversely, the selection of short or intermediate cable lengths requiring less compensation will cause serious under-compensation for longer length cables. The compensation or equalization must be adaptive to ensure proper conditioning of the received signal independent of the cable length.

The DP83848x uses an extremely robust equalization scheme referred as ‘*Digital Adaptive Equalization*.’

The Digital Equalizer removes ISI (inter-symbol interference) from the receive data stream by continuously adapting to provide a filter with the inverse frequency response of the channel. Equalization is combined with an adaptive gain control stage. This enables the receive ‘eye pattern’ to be opened sufficiently to allow very reliable data recovery.

The curves given in [Figure 6-7](#) illustrate attenuation at certain frequencies for given cable lengths. This is derived from the worst case frequency vs attenuation figures as specified in the EIA/TIA Bulletin TSB-36. These curves indicate the significant variations in signal attenuation that must be compensated for by the receive adaptive equalization circuit.

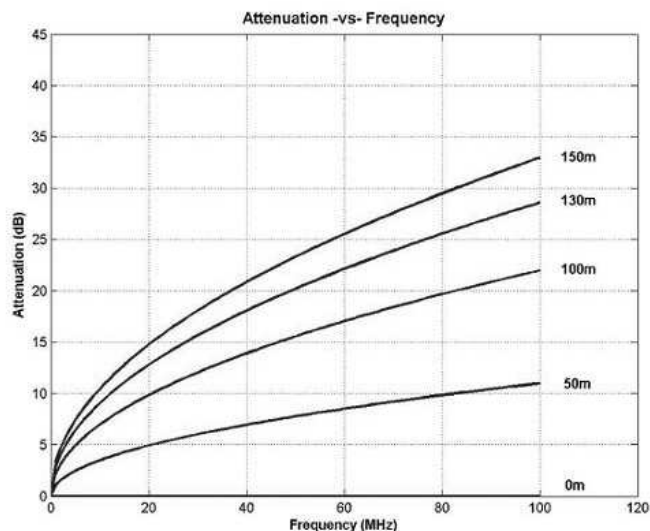

Figure 6-7. EIA/TIA Attenuation vs Frequency for 0, 50, 100, 130 and 150 Meters of CAT 5 Cable

6.5.1.2.4 Base Line Wander Compensation

The DP83848x is completely ANSI TP-PMD compliant and includes Base Line Wander (BLW) compensation. The BLW compensation block can successfully recover the TP-PMD defined “killer” pattern.

BLW can generally be defined as the change in the average DC content, relatively short period over time, of an AC coupled digital transmission over a given transmission medium (that is, copper wire).

BLW results from the interaction between the low-frequency components of a transmitted bit stream and the frequency response of the AC coupling components within the transmission system. If the low-frequency content of the digital bit stream goes below the low-frequency pole of the AC coupling transformers then the droop characteristics of the transformers will dominate resulting in potentially serious BLW.

The digital oscilloscope plot provided in Figure 6-8 illustrates the severity of the BLW event that can theoretically be generated during 100BASE-TX packet transmission. This event consists of approximately 800 mV of DC offset for a period of 120 μs. Left uncompensated, events such as this can cause packet loss.

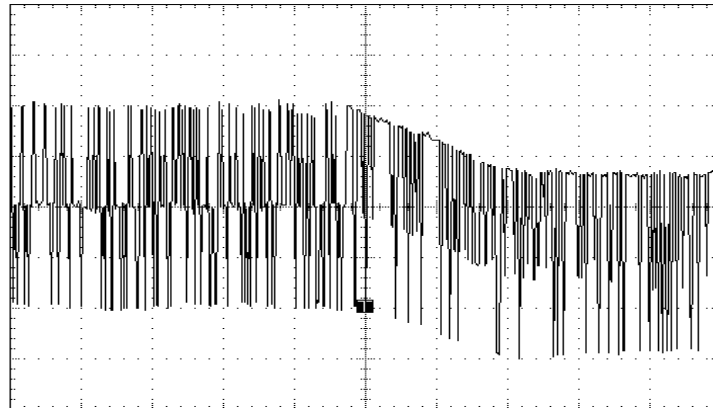

Figure 6-8. 100BASE-TX BLW Event

6.5.1.2.5 Signal Detect

The signal detect function of the DP83848x is incorporated to meet the specifications mandated by the ANSI FDDI TP-PMD Standard as well as the IEEE 802.3 100BASE-TX Standard for both voltage thresholds and timing parameters.

Note that the reception of normal 10BASE-T link pulses and fast link pulses per IEEE 802.3 Auto-Negotiation by the 100BASE-TX receiver do not cause the DP83848x to assert signal detect.

6.5.1.2.6 MLT-3 to NRZI Decoder

The DP83848x decodes the MLT-3 information from the Digital Adaptive Equalizer block to binary NRZI data.

6.5.1.2.7 NRZI to NRZ

In a typical application, the NRZI to NRZ decoder is required in order to present NRZ formatted data to the descrambler.

6.5.1.2.8 Serial to Parallel

The 100BASE-TX receiver includes a Serial to Parallel converter which supplies 5-bit wide data symbols to the PCS Rx state machine.

6.5.1.2.9 Descrambler

A serial descrambler is used to de-scramble the received NRZ data. The descrambler has to generate an identical data scrambling sequence (N) in order to recover the original unscrambled data (UD) from the scrambled data (SD) as represented in the equations:

$$SD = (UD \oplus N) \tag{1}$$

$$UD = (SD \oplus N) \tag{2}$$

Synchronization of the descrambler to the original scrambling sequence (N) is achieved based on the knowledge that the incoming scrambled data stream consists of scrambled IDLE data. After the descrambler has recognized 12 consecutive IDLE code-groups, where an unscrambled IDLE code-group in 5B NRZ is equal to five consecutive ones (11111), it will synchronize to the receive data stream and generate unscrambled data in the form of unaligned 5B code-groups.

In order to maintain synchronization, the descrambler must continuously monitor the validity of the unscrambled data that it generates. To ensure this, a line state monitor and a hold timer are used to constantly monitor the synchronization status. Upon synchronization of the descrambler the hold timer starts a 722- μ s countdown. Upon detection of sufficient IDLE code-groups (58 bit times) within the 722- μ s period, the hold timer will reset and begin a new countdown. This monitoring operation will continue indefinitely given a properly operating network connection with good signal integrity. If the line state monitor does not recognize sufficient unscrambled IDLE code-groups within the 722- μ s period, the entire descrambler will be forced out of the current state of synchronization and reset in order to re-acquire synchronization.

6.5.1.2.10 Code-Group Alignment

The code-group alignment module operates on unaligned 5-bit data from the descrambler (or, if the descrambler is bypassed, directly from the NRZI/NRZ decoder) and converts it into 5B code-group data (5 bits). Code-group alignment occurs after the J/K code-group pair is detected. Once the J/K code-group pair (11000 10001) is detected, subsequent data is aligned on a fixed boundary.

6.5.1.2.11 4B/5B Decoder

The code-group decoder functions as a look up table that translates incoming 5B code-groups into 4B nibbles. The code-group decoder first detects the J/K code-group pair preceded by IDLE code-groups and replaces the J/K with MAC preamble. Specifically, the J/K 10-bit code-group pair is replaced by the nibble pair (0101 0101). All subsequent 5B code-groups are converted to the corresponding 4B nibbles for the duration of the entire packet. This conversion ceases upon the detection of the T/R code-group pair denoting the End of Stream Delimiter (ESD) or with the reception of a minimum of two IDLE code-groups.

6.5.1.2.12 100BASE-TX Link Integrity Monitor

The 100 Base TX Link monitor ensures that a valid and stable link is established before enabling both the Transmit and Receive PCS layer.

Signal detect must be valid for 395 μ s to allow the link monitor to enter the 'Link Up' state, and enable the transmit and receive functions.

6.5.1.2.13 Bad SSD Detection

A Bad Start of Stream Delimiter (Bad SSD) is any transition from consecutive idle code-groups to non-idle code-groups which is not prefixed by the code-group pair /J/K.

If this condition is detected, the DP83848x will assert RX_ER and present RXD[3:0] = 1110 to the MII for the cycles that correspond to received 5B code-groups until at least two IDLE code groups are detected. In addition, the False Carrier Sense Counter register (FCSCR) will be incremented by one.

Once at least two IDLE code groups are detected, RX_ER and CRS become deasserted.

6.5.1.3 10BASE-T Transceiver Module

The 10BASE-T Transceiver Module is IEEE 802.3 compliant. It includes the receiver, transmitter, collision, heart-beat, loopback, jabber, and link integrity functions, as defined in the standard. An external filter is not required on the 10BASE-T interface because this is integrated inside the DP83848x. This section focuses on the general 10BASE-T system level operation.

6.5.1.3.1 Operational Modes

The DP83848x has two basic 10BASE-T operational modes:

- Half Duplex mode
- Full Duplex mode

Half Duplex Mode— In Half Duplex mode the DP83848x functions as a standard IEEE 802.3 10BASE-T transceiver supporting the CSMA/CD protocol.

Full Duplex Mode — In Full Duplex mode the DP83848x is capable of simultaneously transmitting and receiving without asserting the collision signal. The DP83848x's 10 Mb/s ENDEC is designed to encode and decode simultaneously.

6.5.1.3.2 Smart Squelch

The smart squelch is responsible for determining when valid data is present on the differential receive inputs. The DP83848x implements an intelligent receive squelch to ensure that impulse noise on the receive inputs will not be mistaken for a valid signal. Smart-squelch operation is independent of the 10BASE-T operational mode.

The squelch circuitry employs a combination of amplitude and timing measurements (as specified in the IEEE 802.3 10BSE-T standard) to determine the validity of data on the twisted-pair inputs (refer to Figure 6-9).

The signal at the start of a packet is checked by the smart squelch and any pulses not exceeding the squelch level (either positive or negative, depending upon polarity) will be rejected. Once this first squelch level is overcome correctly, the opposite squelch level must then be exceeded within 150 ns. Finally, the signal must again exceed the original squelch level within a 150 ns to ensure that the input waveform will not be rejected. This checking procedure results in the loss of typically three preamble bits at the beginning of each packet.

Only after all these conditions have been satisfied will a control signal be generated to indicate to the remainder of the circuitry that valid data is present. At this time, the smart squelch circuitry is reset.

Valid data is considered to be present until the squelch level has not been generated for a time longer than 150 ns, indicating the End of Packet. Once good data has been detected, the squelch levels are reduced to minimize the effect of noise causing premature End of Packet detection.

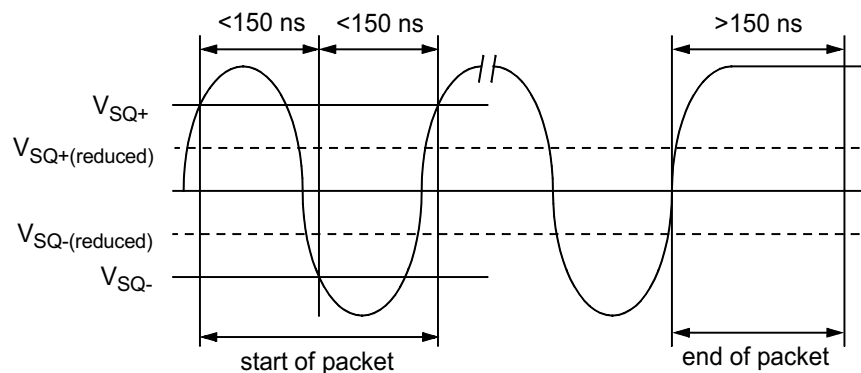

Figure 6-9. 10BASE-T Twisted Pair Smart Squelch Operation

6.5.1.3.3 Collision Detection and SQE

When in Half Duplex, a 10BASE-T collision is detected when the receive and transmit channels are active simultaneously. Collisions are reported by the COL signal on the MII. Collisions are also reported when a jabber condition is detected.

The COL signal remains set for the duration of the collision. If the PHY is receiving when a collision is detected it is reported immediately (through the COL pin).

When heartbeat is enabled, approximately 1 μ s after the transmission of each packet, a Signal Quality Error (SQE) signal of approximately 10-bit times is generated to indicate successful transmission. SQE is reported as a pulse on the COL signal of the MII.

The SQE test is inhibited when the PHY is set in full duplex mode. SQE can also be inhibited by setting the HEARTBEAT_DIS bit in the 10BTSCR register.

6.5.1.3.4 Carrier Sense

Carrier Sense (CRS) may be asserted due to receive activity once valid data is detected through the squelch function.

For 10 Mb/s Half Duplex operation, CRS is asserted during either packet transmission or reception.

For 10 Mb/s Full Duplex operation, CRS is asserted only during receive activity.

CRS is deasserted following an end of packet.

6.5.1.3.5 Normal Link Pulse Detection/Generation

The link pulse generator produces pulses as defined in the IEEE 802.3 10BASE-T standard. Each link pulse is nominally 100 ns in duration and transmitted every 16 ms in the absence of transmit data.

Link pulses are used to check the integrity of the connection with the remote end. If valid link pulses are not received, the link detector disables the 10BASE-T twisted pair transmitter, receiver and collision detection functions.

When the link integrity function is disabled (FORCE_LINK_10 of the 10BTSCR register), a good link is forced and the 10BASE-T transceiver will operate regardless of the presence of link pulses.

6.5.1.3.6 Jabber Function

The jabber function monitors the DP83848x's output and disables the transmitter if it attempts to transmit a packet of longer than legal size. A jabber timer monitors the transmitter and disables the transmission if the transmitter is active for approximately 85 ms.

Once disabled by the Jabber function, the transmitter stays disabled for the entire time that the ENDEC module's internal transmit enable is asserted. This signal has to be deasserted for approximately 500 ms (the "unjab" time) before the Jabber function re-enables the transmit outputs.

The Jabber function is only relevant in 10BASE-T mode.

6.5.1.3.7 Automatic Link Polarity Detection and Correction

The DP83848x's 10BASE-T transceiver module incorporates an automatic link polarity detection circuit. When three consecutive inverted link pulses are received, bad polarity is reported.

A polarity reversal can be caused by a wiring error at either end of the cable, usually at the Main Distribution Frame (MDF) or patch panel in the wiring closet.

The bad polarity condition is latched in the 10BTSCR register. The DP83848x's 10BASE-T transceiver module corrects for this error internally and will continue to decode received data correctly. This eliminates the need to correct the wiring error immediately.

6.5.1.3.8 Transmit and Receive Filtering

External 10BASE-T filters are not required when using the DP83848x, as the required signal conditioning is integrated into the device.

Only isolation transformers and impedance matching resistors are required for the 10BASE-T transmit and receive interface. The internal transmit filtering ensures that all the harmonics in the transmit signal are attenuated by at least 30 dB.

6.5.1.3.9 Transmitter

The encoder begins operation when the Transmit Enable input (TX_EN) goes high and converts NRZ data to pre-emphasized Manchester data for the transceiver. For the duration of TX_EN, the serialized Transmit Data (TXD) is encoded for the transmit-driver pair (PMD Output Pair). TXD must be valid on the rising edge of Transmit Clock (TX_CLK). Transmission ends when TX_EN deasserts. The last transition is always positive; it occurs at the center of the bit cell if the last bit is a one, or at the end of the bit cell if the last bit is a zero.

6.5.1.3.10 Receiver

The decoder detects the end of a frame when no additional mid-bit transitions are detected. Within one and a half bit times after the last bit, carrier sense is deasserted. Receive clock stays active for five more bit times after CRS goes low, to ensure the receive timings of the controller.

6.6 Memory

6.6.1 Register Block

Table 6-7. Register Map

Offset		Access	Tag	Description
Hex	Decimal			
00h	0	RW	BMCR	Basic Mode Control Register
01h	1	RO	BMSR	Basic Mode Status Register
02h	2	RO	PHYIDR1	PHY Identifier Register #1
03h	3	RO	PHYIDR2	PHY Identifier Register #2
04h	4	RW	ANAR	Auto-Negotiation Advertisement Register
05h	5	RW	ANLPAR	Auto-Negotiation Link Partner Ability Register (Base Page)
05h	5	RW	ANLPARNP	Auto-Negotiation Link Partner Ability Register (Next Page)
06h	6	RW	ANER	Auto-Negotiation Expansion Register
07h	7	RW	ANNPTR	Auto-Negotiation Next Page TX
08h-Fh	8-15	RW	RESERVED	RESERVED
EXTENDED REGISTERS				
10h	16	RO	PHYSTS	PHY Status Register
11h	17	RW	RESERVED	RESERVED
12h	18	RO	RESERVED	RESERVED
13h	19	RW	RESERVED	RESERVED
14h	20	RW	FCSCR	False Carrier Sense Counter Register
15h	21	RW	RECR	Receive Error Counter Register
16h	22	RW	PCSR	PCS Sub-Layer Configuration and Status Register
17h	23	RW	RBR	RMI and Bypass Register
18h	24	RW	LEDCR	LED Direct Control Register
19h	25	RW	PHYCR	PHY Control Register
1Ah	26	RW	10BTSCR	10Base-T Status/Control Register
1Bh	27	RW	CDCTRL1	CD Test Control Register and BIST Extensions Register
1Ch	28	RW	RESERVED	RESERVED
1Dh	29	RW	EDCR	Energy Detect Control Register
1Eh-1Fh	30-31	RW	RESERVED	RESERVED

Table 6-8. Register Table

Register Name	Addr	Tag	Bit 15	Bit 14	Bit 13	Bit 12	Bit 11	Bit 10	Bit 9	Bit 8	Bit 7	Bit 6	Bit 5	Bit 4	Bit 3	Bit 2	Bit 1	Bit 0	
Basic Mode Control Register	00h	BMCR	Reset	Loopback	Speed Selection	AutoNeg Enable	Power Down	Isolate	Restart AutoNeg	Duplex Mode	Collision Test	Reserved	Reserved	Reserved	Reserved	Reserved	Reserved	Reserved	
Basic Mode Status Register	01h	BMSR	100Base-T4	100Base-TX FDX	100Base-TX HDX	10Base-TFDX	10Base-THDX	Reserved	Reserved	Reserved	Reserved	MF Preamble Suppress	Auto-Neg Complete	Remote Fault	Auto-Neg Ability	Link Status	Jabber Detect	Extended Capability	
PHY Identifier Register 1	02h	PHYIDR1	OUI MSB	OUI MSB	OUI MSB	OUI MSB	OUI MSB	OUI MSB	OUI MSB	OUI MSB	OUI MSB	OUI MSB	OUI MSB	OUI MSB	OUI MSB	OUI MSB	OUI MSB	OUI MSB	
PHY Identifier Register 2	03h	PHYIDR2	OUI LSB	OUI LSB	OUI LSB	OUI LSB	OUI LSB	OUI LSB	VNDR_MDL	VNDR_MDL	VNDR_MDL	VNDR_MDL	VNDR_MDL	VNDR_MDL	MDL_REV	MDL_REV	MDL_REV	MDL_REV	
Auto-Negotiation Advertisement Register	04h	ANAR	Next Page Ind	Reserved	Remote Fault	Reserved	ASM_DI R	PAUSE	T4	TX_FD	TX	10_FD	10	Protocol Selection	Protocol Selection	Protocol Selection	Protocol Selection	Protocol Selection	
Auto-Negotiation Link Partner Ability Register (Base Page)	05h	ANLPAR	Next Page Ind	ACK	RemoteFault	Reserved	ASM_DI R	PAUSE	T4	TX_FD	TX	10_FD	10	Protocol Selection	Protocol Selection	Protocol Selection	Protocol Selection	Protocol Selection	
Auto-Negotiation Link Partner Ability Register Next Page	05h	ANLPARN P	Next Page Ind	ACK	Message Page	ACK2	Toggle	Code	Code	Code	Code	Code	Code	Code	Code	Code	Code	Code	
Auto-Negotiation Expansion Register	06h	ANER	Reserved	Reserved	Reserved	Reserved	Reserved	Reserved	Reserved	Reserved	Reserved	Reserved	Reserved	PDF	LP_NP_ABLE	NP_ABLE	PAGE_RX	LP_AN_ABLE	
Auto-Negotiation Next Page TX Register	07h	ANNPTR	Next Page Ind	Reserved	Message Page	ACK2	TOG_TX	CODE	CODE	CODE	CODE	CODE	CODE	CODE	CODE	CODE	CODE	CODE	
RESERVED	08-0fh	Reserved	Reserved	Reserved	Reserved	Reserved	Reserved	Reserved	Reserved	Reserved	Reserved	Reserved	Reserved	Reserved	Reserved	Reserved	Reserved	Reserved	
EXTENDED REGISTERS																			
PHY Status Register	10h	PHYSTS	Reserved	MDI-X mode	Rx Err Latch	Polarity Status	False Carrier Sense	Signal Detect	Descram Lock	Page Receive	Reserved	Remote Fault	Jabber Detect	Auto-Neg Complete	Loopback Status	Duplex Status	Speed Status	Link Status	
RESERVED	11h	Reserved	Reserved	Reserved	Reserved	Reserved	Reserved	Reserved	Reserved	Reserved	Reserved	Reserved	Reserved	Reserved	Reserved	Reserved	Reserved	Reserved	
RESERVED	12h	Reserved	Reserved	Reserved	Reserved	Reserved	Reserved	Reserved	Reserved	Reserved	Reserved	Reserved	Reserved	Reserved	Reserved	Reserved	Reserved	Reserved	
RESERVED	13h	Reserved	Reserved	Reserved	Reserved	Reserved	Reserved	Reserved	Reserved	Reserved	Reserved	Reserved	Reserved	Reserved	Reserved	Reserved	Reserved	Reserved	
False Carrier Sense Counter Register	14h	FCSCR	Reserved	Reserved	Reserved	Reserved	Reserved	Reserved	Reserved	Reserved	FCSCNT	FCSCNT	FCSCNT	FCSCNT	FCSCNT	FCSCNT	FCSCNT	FCSCNT	
Receive Error Counter Register	15h	RECR	Reserved	Reserved	Reserved	Reserved	Reserved	Reserved	Reserved	Reserved	RXERCNT	RXERCNT	RXERCNT	RXERCNT	RXERCNT	RXERCNT	RXERCNT	RXERCNT	
PCS Sub-Layer Configuration and Status Register	16h	PCSR	Reserved	Reserved	Reserved	Reserved	Reserved	TQ_EN	SD_FOR CE_PMA	SD_OPTION	DESC_T IME	Reserved	FORCE_100_OK	Reserved	Reserved	NRZL_BYPASS	SCRAM_BYPASS	DE SCRAM_BYPASS	
RMII and Bypass Register	17h	RBR	Reserved	Reserved	Reserved	Reserved	Reserved	Reserved	Reserved	Reserved	Reserved	Reserved	RMII_M ODE	RMII_RE V1_0	RX_OVF _STS	RX_UNF _STS	RX_RD_ PTR[1]	RX_RD_ PTR[0]	
LED Direct Control Register	18h	LEDCR	Reserved	Reserved	Reserved	Reserved	Reserved	Reserved	Reserved	Reserved	Reserved	Reserved	DRV_SP ⁽¹⁾ DLED	DRV_LN KLED	Reserved	SPDLED ⁽¹⁾	LNKLED	Reserved	
PHY Control Register	19h	PHYCR	MDIX_E N	FORCE_ MDIX	PAUSE_ RX	PAUSE_ TX	BIST_fe	PSR_15	BIST_ STATUS	BIST_ST ART	BP_STR ETCH	Reserved	LED_ CNFG[0]	PHY ADDR	PHY ADDR	PHY ADDR	PHY ADDR	PHY ADDR	
10Base-T Status/Control Register	1Ah	10BT_ S CR	Reserved	Reserved	Reserved	Reserved	SQUELC H	SQUELC H	SQUELC H	LOOPBA CK_10_ DIS	LP_DIS	FORC_ LINK_10	Reserved	POLARITY	Reserved	Reserved	HEART_ DIS	JABBER_ DIS	
CD Test Control and BIST Extensions Register	1Bh	CDCTRL1	BIST_ER ROR_C OUNT	BIST_ER ROR_C OUNT	BIST_ER ROR_C OUNT	BIST_ER ROR_C OUNT	BIST_ER ROR_C OUNT	BIST_ER ROR_C OUNT	BIST_ER ROR_C OUNT	BIST_ER ROR_C OUNT	BIST_ER ROR_C OUNT	Reserved	Reserved	BIST_C ONT_M ODE	CDPattE N_10	Reserved	10Meg_ Patt_Ga p	CDPatt- Sel	CDPatt- Sel

(1) DP83848J/K only.

Table 6-8. Register Table (continued)

Register Name	Addr	Tag	Bit 15	Bit 14	Bit 13	Bit 12	Bit 11	Bit 10	Bit 9	Bit 8	Bit 7	Bit 6	Bit 5	Bit 4	Bit 3	Bit 2	Bit 1	Bit 0
RESERVED	1Ch	Reserved	Reserved	Reserved	Reserved	Reserved	Reserved	Reserved	Reserved	Reserved	Reserved	Reserved	Reserved	Reserved	Reserved	Reserved	Reserved	Reserved
Energy Detect Control Register	1Dh	EDCR	ED_EN	ED_AUTO_UP	ED_AUTO_DOWN	ED_MAN	ED_BURST_DIS	ED_PWR_STATE	ED_ERR_MET	ED_DATA_MET	ED_ERR_COUNT	ED_ERR_COUNT	ED_ERR_COUNT	ED_ERR_COUNT	ED_DATA_COUNT	ED_DATA_COUNT	ED_DATA_COUNT	ED_DATA_COUNT
RESERVED	1Eh-1Fh	Reserved	Reserved	Reserved	Reserved	Reserved	Reserved	Reserved	Reserved	Reserved	Reserved	Reserved	Reserved	Reserved	Reserved	Reserved	Reserved	Reserved

6.6.1.1 Register Definition

In the register definitions under the ‘Default’ heading, the following definitions hold true:

- **RW** = Read Write access
- **SC** = Register sets on event occurrence and **Self-Clears** when event ends
- **RW/SC** = Read Write access/**Self Clearing** bit
- **RO** = Read Only access
- **COR** = Clear on Read
- **RO/COR** = Read Only, Clear on Read
- **RO/P** = Read Only, Permanently set to a default value
- **LL** = Latched Low and held until read, based upon the occurrence of the corresponding event
- **LH** = Latched High and held until read, based upon the occurrence of the corresponding event

6.6.1.1.1 Basic Mode Control Register (BMCR)

Table 6-9. Basic Mode Control Register (BMCR), address 0x00

Bit	Bit Name	Default	Description
15	Reset	0, RW/SC	Reset: 1 = Initiate software Reset / Reset in Process. 0 = Normal operation. This bit, which is self-clearing, returns a value of one until the reset process is complete. The configuration is re-strapped.
14	Loopback	0, RW	Loopback: 1 = Loopback enabled. 0 = Normal operation. The loopback function enables MII transmit data to be routed to the MII receive data path. Setting this bit may cause the descrambler to lose synchronization and produce a 500 µs “dead time” before any valid data will appear at the MII receive outputs.
13	Speed Selection	RW	Speed Select: When auto-negotiation is disabled writing to this bit allows the port speed to be selected. 1 = 100 Mb/s. 0 = 10 Mb/s.
12	Auto-Negotiation Enable	RW	Auto-Negotiation Enable: Strap controls initial value at reset. 1 = Auto-Negotiation Enabled - bits 8 and 13 of this register are ignored when this bit is set. 0 = Auto-Negotiation Disabled - bits 8 and 13 determine the port speed and duplex mode.
11	Power Down	0, RW	Power Down: 1 = Power down. 0 = Normal operation. Setting this bit powers down the PHY. Only the register block is enabled during a power-down condition.
10	Isolate	0, RW	Isolate: 1 = Isolates the Port from the MII with the exception of the serial management. 0 = Normal operation.
9	Restart Auto-Negotiation	0, RW/SC	Restart Auto-Negotiation: 1 = Restart Auto-Negotiation. Re-initiates the Auto-Negotiation process. If Auto-Negotiation is disabled (bit 12 = 0), this bit is ignored. This bit is self-clearing and will return a value of 1 until Auto-Negotiation is initiated, whereupon it will self-clear. Operation of the Auto-Negotiation process is not affected by the management entity clearing this bit. 0 = Normal operation.
8	Duplex Mode	RW	Duplex Mode: When auto-negotiation is disabled writing to this bit allows the port Duplex capability to be selected. 1 = Full Duplex operation. 0 = Half Duplex operation.

Table 6-9. Basic Mode Control Register (BMCR), address 0x00 (continued)

Bit	Bit Name	Default	Description
7	Collision Test	0, RW	<p>Collision Test: 1 = Collision test enabled. 0 = Normal operation.</p> <p>When set, this bit will cause the COL signal to be asserted in response to the assertion of TX_EN within 512-bit times. The COL signal will be deasserted within 4-bit times in response to the deassertion of TX_EN.</p>
6:0	RESERVED	0, RO	RESERVED: Write ignored, read as 0.

6.6.1.1.2 Basic Mode Status Register (BMSR)

Table 6-10. Basic Mode Status Register (BMSR), address 0x01

Bit	Bit Name	Default	Description
15	100BASE-T4	0, RO/P	<p>100BASE-T4 Capable: 0 = Device not able to perform 100BASE-T4 mode.</p>
14	100BASE-TX Full Duplex	1, RO/P	<p>100BASE-TX Full Duplex Capable: 1 = Device able to perform 100BASE-TX in full duplex mode.</p>
13	100BASE-TX Half Duplex	1, RO/P	<p>100BASE-TX Half Duplex Capable: 1 = Device able to perform 100BASE-TX in half duplex mode.</p>
12	10BASE-T Full Duplex	1, RO/P	<p>10BASE-T Full Duplex Capable: 1 = Device able to perform 10BASE-T in full duplex mode.</p>
11	10BASE-T Half Duplex	1, RO/P	<p>10BASE-T Half Duplex Capable: 1 = Device able to perform 10BASE-T in half duplex mode.</p>
10:7	RESERVED	0, RO	RESERVED: Write as 0, read as 0.
6	MF Preamble Suppression	1, RO/P	<p>Preamble suppression Capable: 1 = Device able to perform management transaction with preamble suppressed, 32-bits of preamble needed only once after reset, invalid opcode or invalid turnaround. 0 = Normal management operation.</p>
5	Auto-Negotiation Complete	0, RO	<p>Auto-Negotiation Complete: 1 = Auto-Negotiation process complete. 0 = Auto-Negotiation process not complete.</p>
4	Remote Fault	0, RO/LH	<p>Remote Fault: 1 = Remote Fault condition detected (cleared on read or by reset). Fault criteria: Notification from Link Partner of Remote Fault. 0 = No remote fault condition detected.</p>
3	Auto-Negotiation Ability	1, RO/P	<p>Auto Negotiation Ability: 1 = Device is able to perform Auto-Negotiation. 0 = Device is not able to perform Auto-Negotiation.</p>
2	Link Status	0, RO/LL	<p>Link Status: 1 = Valid link established (for either 10 or 100 Mb/s operation). 0 = Link not established.</p> <p>The criteria for link validity is implementation specific. The occurrence of a link failure condition will causes the Link Status bit to clear. Once cleared, this bit may only be set by establishing a good link condition and a read through the management interface.</p>
1	Jabber Detect	0, RO/LH	<p>Jabber Detect: This bit only has meaning in 10 Mb/s mode. 1 = Jabber condition detected. 0 = No Jabber.</p> <p>This bit is implemented with a latching function, such that the occurrence of a jabber condition causes it to set until it is cleared by a read to this register by the management interface or by a reset.</p>
0	Extended Capability	1, RO/P	<p>Extended Capability: 1 = Extended register capabilities. 0 = Basic register set capabilities only.</p>

The PHY Identifier Registers #1 and #2 together form a unique identifier for the DP83848x. The Identifier consists of a concatenation of the Organizationally Unique Identifier (OUI), the vendor's model number and the model revision number. A PHY may return a value of zero in each of the 32 bits of the PHY Identifier if desired. The PHY Identifier is intended to support network management. National's IEEE assigned OUI is 080017h.

6.6.1.1.3 PHY Identifier Register #1 (PHYIDR1)

Table 6-11. PHY Identifier Register #1 (PHYIDR1), address 0x02

Bit	Bit Name	Default	Description
15:0	OUI_MSB	<0010 0000 0000 0000>, RO/P	OUI Most Significant Bits: Bits 3 to 18 of the OUI (080017h) are stored in bits 15 to 0 of this register. The most significant two bits of the OUI are ignored (the IEEE standard refers to these as bits 1 and 2).

6.6.1.1.4 PHY Identifier Register #2 (PHYIDR2)

Table 6-12. PHY Identifier Register #2 (PHYIDR2), address 0x03

Bit	Bit Name	Default	Description
15:10	OUI_LSB	<0101 11>, RO/P	OUI Least Significant Bits: Bits 19 to 24 of the OUI (080017h) are mapped from bits 15 to 10 of this register respectively.
9:4	VNDR_MDL	<00 1001>, RO/P	Vendor Model Number: The six bits of vendor model number are mapped from bits 9 to 4 (most significant bit to bit 9).
3:0	MDL_REV	<0000>, RO/P	Model Revision Number: Four bits of the vendor model revision number are mapped from bits 3 to 0 (most significant bit to bit 3). This field will be incremented for all major device changes.

6.6.1.1.5 Auto-Negotiation Advertisement Register (ANAR)

This register contains the advertised abilities of this device as they will be transmitted to its link partner during Auto-Negotiation. Any writes to this register prior to completion of Auto-Negotiation (as indicated in the Basic Mode Status Register (address 0x01) Auto-Negotiation complete bit, BMSR[5]) should be followed by a renegotiation. This will ensure that the new values are properly used in the Auto-Negotiation.

Table 6-13. Auto-Negotiation Advertisement Register (ANAR), address 0x04

Bit	Bit Name	Default	Description
15	NP	0, RW	Next Page Indication: 0 = Next Page Transfer not desired. 1 = Next Page Transfer desired.
14	RESERVED	0, RO/P	RESERVED by IEEE: Writes ignored, Read as 0.
13	RF	0, RW	Remote Fault: 1 = Advertises that this device has detected a Remote Fault. 0 = No Remote Fault detected.
12	RESERVED	0, RW	RESERVED for Future IEEE use: Write as 0, Read as 0
11	ASM_DIR	0, RW	Asymmetric PAUSE Support for Full Duplex Links: The ASM_DIR bit indicates that asymmetric PAUSE is supported. Encoding and resolution of PAUSE bits is defined in IEEE 802.3 Annex 28B, Tables 28B-2 and 28B-3, respectively. Pause resolution status is reported in PHYCR[13:12]. 1 = Advertise that the DTE (MAC) has implemented both the optional MAC control sublayer and the pause function as specified in clause 31 and annex 31B of 802.3. 0= No MAC based full duplex flow control.

Table 6-13. Auto-Negotiation Advertisement Register (ANAR), address 0x04 (continued)

Bit	Bit Name	Default	Description
10	PAUSE	0, RW	<p>PAUSE Support for Full Duplex Links:</p> <p>The PAUSE bit indicates that the device is capable of providing the symmetric PAUSE functions as defined in Annex 31B.</p> <p>Encoding and resolution of PAUSE bits is defined in IEEE 802.3 Annex 28B, Tables 28B-2 and 28B-3, respectively. Pause resolution status is reported in PHYCR[13:12].</p> <p>1 = Advertise that the DTE (MAC) has implemented both the optional MAC control sublayer and the pause function as specified in clause 31 and annex 31B of 802.3.</p> <p>0= No MAC based full duplex flow control.</p>
9	T4	0, RO/P	<p>100BASE-T4 Support:</p> <p>1= 100BASE-T4 is supported by the local device.</p> <p>0 = 100BASE-T4 not supported.</p>
8	TX_FD	Strap, RW	<p>100BASE-TX Full Duplex Support:</p> <p>1 = 100BASE-TX Full Duplex is supported by the local device.</p> <p>0 = 100BASE-TX Full Duplex not supported.</p>
7	TX	Strap, RW	<p>100BASE-TX Support:</p> <p>1 = 100BASE-TX is supported by the local device.</p> <p>0 = 100BASE-TX not supported.</p>
6	10_FD	RW	<p>10BASE-T Full Duplex Support:</p> <p>1 = 10BASE-T Full Duplex is supported by the local device.</p> <p>0 = 10BASE-T Full Duplex not supported.</p>
5	10	RW	<p>10BASE-T Support:</p> <p>1 = 10BASE-T is supported by the local device.</p> <p>0 = 10BASE-T not supported.</p>
4:0	Selector	<00001>, RW	<p>Protocol Selection Bits:</p> <p>These bits contain the binary encoded protocol selector supported by this port. <00001> indicates that this device supports IEEE 802.3.</p>

6.6.1.1.6 Auto-Negotiation Link Partner Ability Register (ANLPAR) (BASE Page)

This register contains the advertised abilities of the Link Partner as received during Auto-Negotiation. The content changes after the successful auto-negotiation if Next-pages are supported.

Table 6-14. Auto-Negotiation Link Partner Ability Register (ANLPAR) (BASE Page), address 0x05

Bit	Bit Name	Default	Description
15	NP	0, RO	<p>Next Page Indication:</p> <p>0 = Link Partner does not desire Next Page Transfer.</p> <p>1 = Link Partner desires Next Page Transfer.</p>
14	ACK	0, RO	<p>Acknowledge:</p> <p>1 = Link Partner acknowledges reception of the ability data word.</p> <p>0 = Not acknowledged.</p> <p>The Auto-Negotiation state machine will automatically control the this bit based on the incoming FLP bursts.</p>
13	RF	0, RO	<p>Remote Fault:</p> <p>1 = Remote Fault indicated by Link Partner.</p> <p>0 = No Remote Fault indicated by Link Partner.</p>
12	RESERVED	0, RO	<p>RESERVED for Future IEEE use:</p> <p>Write as 0, read as 0.</p>
11	ASM_DIR	0, RO	<p>ASYMMETRIC PAUSE:</p> <p>1 = Asymmetric pause is supported by the Link Partner.</p> <p>0 = Asymmetric pause is not supported by the Link Partner.</p>
10	PAUSE	0, RO	<p>PAUSE:</p> <p>1 = Pause function is supported by the Link Partner.</p> <p>0 = Pause function is not supported by the Link Partner.</p>
9	T4	0, RO	<p>100BASE-T4 Support:</p> <p>1 = 100BASE-T4 is supported by the Link Partner.</p> <p>0 = 100BASE-T4 not supported by the Link Partner.</p>

Table 6-14. Auto-Negotiation Link Partner Ability Register (ANLPAR) (BASE Page), address 0x05 (continued)

Bit	Bit Name	Default	Description
8	TX_FD	0, RO	100BASE-TX Full Duplex Support: 1 = 100BASE-TX Full Duplex is supported by the Link Partner. 0 = 100BASE-TX Full Duplex not supported by the Link Partner.
7	TX	0, RO	100BASE-TX Support: 1 = 100BASE-TX is supported by the Link Partner. 0 = 100BASE-TX not supported by the Link Partner.
6	10_FD	0, RO	10BASE-T Full Duplex Support: 1 = 10BASE-T Full Duplex is supported by the Link Partner. 0 = 10BASE-T Full Duplex not supported by the Link Partner.
5	10	0, RO	10BASE-T Support: 1 = 10BASE-T is supported by the Link Partner. 0 = 10BASE-T not supported by the Link Partner.
4:0	Selector	<0 0000>, RO	Protocol Selection Bits: Link Partner's binary encoded protocol selector.

6.6.1.1.7 Auto-Negotiation Link Partner Ability Register (ANLPAR) (Next Page)
Table 6-15. Auto-Negotiation Link Partner Ability Register (ANLPAR) (Next Page), address 0x05

Bit	Bit Name	Default	Description
15	NP	0, RO	Next Page Indication: 1 = Link Partner desires Next Page Transfer. 0 = Link Partner does not desire Next Page Transfer.
14	ACK	0, RO	Acknowledge: 1 = Link Partner acknowledges reception of the ability data word. 0 = Not acknowledged. The Auto-Negotiation state machine will automatically control the this bit based on the incoming FLP bursts. Software should not attempt to write to this bit.
13	MP	0, RO	Message Page: 1 = Message Page. 0 = Unformatted Page.
12	ACK2	0, RO	Acknowledge 2: 1 = Link Partner does have the ability to comply to next page message. 0 = Link Partner does not have the ability to comply to next page message.
11	Toggle	0, RO	Toggle: 1 = Previous value of the transmitted Link Code word equaled 0. 0 = Previous value of the transmitted Link Code word equaled 1.
10:0	CODE	<000 0000 0000>, RO	Code: This field represents the code field of the next page transmission. If the MP bit is set (bit 13 of this register), then the code shall be interpreted as a "Message Page," as defined in annex 28C of Clause 28. Otherwise, the code shall be interpreted as an "Unformatted Page," and the interpretation is application specific.

6.6.1.1.8 Auto-Negotiate Expansion Register (ANER)

This register contains additional Local Device and Link Partner status information.

Table 6-16. Auto-Negotiate Expansion Register (ANER), address 0x06

Bit	Bit Name	Default	Description
15:5	RESERVED	0, RO	RESERVED: Writes ignored, Read as 0.
4	PDF	0, RO	Parallel Detection Fault: 1 = A fault has been detected through the Parallel Detection function. 0 = A fault has not been detected.
3	LP_NP_ABLE	0, RO	Link Partner Next Page Able: 1 = Link Partner does support Next Page. 0 = Link Partner does not support Next Page.
2	NP_ABLE	1, RO/P	Next Page Able: 1 = Indicates local device is able to send additional "Next Pages".
1	PAGE_RX	0, RO/COR	Link Code Word Page Received: 1 = Link Code Word has been received, cleared on a read. 0 = Link Code Word has not been received.
0	LP_AN_ABLE	0, RO	Link Partner Auto-Negotiation Able: 1 = indicates that the Link Partner supports Auto-Negotiation. 0 = indicates that the Link Partner does not support Auto-Negotiation.

6.6.1.1.9 Auto-Negotiation Next Page Transmit Register (ANNPTR)

This register contains the next page information sent by this device to its Link Partner during Auto-Negotiation.

Table 6-17. Auto-Negotiation Next Page Transmit Register (ANNPTR), address 0x07

Bit	Bit Name	Default	Description
15	NP	0, RW	Next Page Indication: 0 = No other Next Page Transfer desired. 1 = Another Next Page desired.
14	RESERVED	0, RO	RESERVED: Writes ignored, read as 0.
13	MP	1, RW	Message Page: 1 = Message Page. 0 = Unformatted Page.
12	ACK2	0, RW	Acknowledge2: 1 = Will comply with message. 0 = Cannot comply with message. Acknowledge2 is used by the next page function to indicate that Local Device has the ability to comply with the message received.
11	TOG_TX	0, RO	Toggle: 1 = Value of toggle bit in previously transmitted Link Code Word was 0. 0 = Value of toggle bit in previously transmitted Link Code Word was 1. Toggle is used by the Arbitration function within Auto-Negotiation to ensure synchronization with the Link Partner during Next Page exchange. This bit shall always take the opposite value of the Toggle bit in the previously exchanged Link Code Word.
10:0	CODE	<000 0000 0001>, RW	This field represents the code field of the next page transmission. If the MP bit is set (bit 13 of this register), then the code shall be interpreted as a "Message Page", as defined in annex 28C of IEEE 802.3. Otherwise, the code shall be interpreted as an "Unformatted Page", and the interpretation is application specific. The default value of the CODE represents a Null Page as defined in Annex 28C of IEEE 802.3.

6.6.1.2 Extended Registers

6.6.1.2.1 PHY Status Register (PHYSTS)

This register provides a single location within the register set for quick access to commonly accessed information.

Table 6-18. PHY Status Register (PHYSTS), address 0x10

Bit	Bit Name	Default	Description
15	RESERVED	0, RO	RESERVED: Write ignored, read as 0.
14	MDI-X mode	0, RO	MDI-X mode as reported by the Auto-Negotiation logic: This bit will be affected by the settings of the MDIX_EN and FORCE_MDIX bits in the PHYCR register. When MDIX is enabled, but not forced, this bit will update dynamically as the Auto-MDIX algorithm swaps between MDI and MDI-X configurations. 1 = MDI pairs swapped (Receive on TPTD pair, Transmit on TPRD pair) 0 = MDI pairs normal (Receive on TRD pair, Transmit on TPTD pair)
13	Receive Error Latch	0, RO/LH	Receive Error Latch: This bit will be cleared upon a read of the RECR register. 1 = Receive error event has occurred since last read of RXERCNT (address 0x15, Page 0). 0 = No receive error event has occurred.
12	Polarity Status	0, RO	Polarity Status: This bit is a duplication of bit 4 in the 10BTSCR register. This bit will be cleared upon a read of the 10BTSCR register, but not upon a read of the PHYSTS register. 1 = Inverted Polarity detected. 0 = Correct Polarity detected.
11	False Carrier Sense Latch	0, RO/LH	False Carrier Sense Latch: This bit will be cleared upon a read of the FCSR register. 1 = False Carrier event has occurred since last read of FCSCR (address 0x14). 0 = No False Carrier event has occurred.
10	Signal Detect	0, RO/LL	100Base-TX unconditional Signal Detect from PMD.
9	Descrambler Lock	0, RO/LL	100Base-TX Descrambler Lock from PMD.
8	Page Received	0, RO	Link Code Word Page Received: This is a duplicate of the Page Received bit in the ANER register, but this bit will not be cleared upon a read of the PHYSTS register. 1 = A new Link Code Word Page has been received. Cleared on read of the ANER (address 0x06, bit 1). 0 = Link Code Word Page has not been received.
7	RESERVED	0, RO	RESERVED: Writes ignored, read as 0.
6	Remote Fault	0, RO	Remote Fault: 1 = Remote Fault condition detected (cleared on read of BMSR (address 01h) register or by reset). Fault criteria: notification from Link Partner of Remote Fault through Auto-Negotiation. 0 = No remote fault condition detected.
5	Jabber Detect	0, RO	Jabber Detect: This bit only has meaning in 10 Mb/s mode This bit is a duplicate of the Jabber Detect bit in the BMSR register, except that it is not cleared upon a read of the PHYSTS register. 1 = Jabber condition detected. 0 = No Jabber.
4	Auto-Neg Complete	0, RO	Auto-Negotiation Complete: 1 = Auto-Negotiation complete. 0 = Auto-Negotiation not complete.
3	Loopback Status	0, RO	Loopback: 1 = Loopback enabled. 0 = Normal operation.

Table 6-18. PHY Status Register (PHYSTS), address 0x10 (continued)

Bit	Bit Name	Default	Description
2	Duplex Status	0, RO	Duplex: This bit indicates duplex status and is determined from Auto-Negotiation or Forced Modes. 1 = Full duplex mode. 0 = Half duplex mode. Note: This bit is only valid if Auto-Negotiation is enabled and complete and there is a valid link or if Auto-Negotiation is disabled and there is a valid link.
1	Speed Status	0, RO	Speed10: This bit indicates the status of the speed and is determined from Auto-Negotiation or Forced Modes. 1 = 10 Mb/s mode. 0 = 100 Mb/s mode. Note: This bit is only valid if Auto-Negotiation is enabled and complete and there is a valid link or if Auto-Negotiation is disabled and there is a valid link.
0	Link Status	0, RO	Link Status: This bit is a duplicate of the Link Status bit in the BMSR register, except that it will not be cleared upon a read of the PHYSTS register. 1 = Valid link established (for either 10 or 100 Mb/s operation) 0 = Link not established.

6.6.1.2.2 False Carrier Sense Counter Register (FCSCR)

This counter provides information required to implement the “False Carriers” attribute within the MAU managed object class of Clause 30 of the IEEE 802.3 specification.

Table 6-19. False Carrier Sense Counter Register (FCSCR), address 0x14

Bit	Bit Name	Default	Description
15:8	RESERVED	0, RO	RESERVED: Writes ignored, Read as 0
7:0	FCSCNT[7:0]	0, RO / COR	False Carrier Event Counter: This 8-bit counter increments on every false carrier event. This counter sticks when it reaches its max count (FFh).

6.6.1.2.3 Receiver Error Counter Register (RECR)

This counter provides information required to implement the “Symbol Error During Carrier” attribute within the PHY managed object class of Clause 30 of the IEEE 802.3 specification.

Table 6-20. Receiver Error Counter Register (RECR), address 0x15

Bit	Bit Name	Default	Description
15:8	RESERVED	0, RO	RESERVED: Writes ignored, Read as 0
7:0	RXERCNT[7:0]	0, RO / COR	RX_ER Counter: When a valid carrier is present and there is at least one occurrence of an invalid data symbol, this 8-bit counter increments for each receive error detected. This event can increment only once per valid carrier event. If a collision is present, the attribute will not increment. The counter sticks when it reaches its max count.

6.6.1.2.4 100 Mb/s PCS Configuration and Status Register (PCSR)
Table 6-21. 100 Mb/s PCS Configuration and Status Register (PCSR), address 0x16

Bit	Bit Name	Default	Description
15:13	RESERVED	<00>, RO	RESERVED: Writes ignored, Read as 0.
12	RESERVED	0	RESERVED: Must be zero.
11	RESERVED	0	RESERVED: Must be zero.
10	TQ_EN	0, RW	100Mbs True Quiet Mode Enable: 1 = Transmit True Quiet Mode. 0 = Normal Transmit Mode.
9	SD_FORCE_PMA	0, RW	Signal Detect Force PMA: 1 = Forces Signal Detection in PMA. 0 = Normal SD operation.
8	SD_OPTION	1, RW	Signal Detect Option: 1 = Enhanced signal detect algorithm. 0 = Reduced signal detect algorithm.
7	DESC_TIME	0, RW	Descrambler Timeout: Increase the descrambler timeout. When set this should allow the device to receive larger packets (>9k bytes) without loss of synchronization. 1 = 2ms 0 = 722us (per ANSI X3.263: 1995 (TP-PMD) 7.2.3.3e)
6	RESERVED	0	RESERVED: Must be zero.
5	FORCE_100_OK	0, RW	Force 100Mb/s Good Link: 1 = Forces 100Mb/s Good Link. 0 = Normal 100Mb/s operation.
4	RESERVED	0	RESERVED: Must be zero.
3	RESERVED	0	RESERVED: Must be zero.
2	NRZI_BYPASS	0, RW	NRZI Bypass Enable: 1 = NRZI Bypass Enabled. 0 = NRZI Bypass Disabled.
1	RESERVED	0	RESERVED: Must be zero.
0	RESERVED	0	RESERVED: Must be zero.

6.6.1.2.5 RMII and Bypass Register (RBR)

This register configures the RMII Mode of operation. When RMII mode is disabled, the RMII functionality is bypassed.

Table 6-22. RMII and Bypass Register (RBR), address 0x17

Bit	Bit Name	Default	Description
15:6	RESERVED	0, RO	RESERVED: Writes ignored, Read as 0.
5	RMII_MODE	Strap, RW	Reduced MII Mode: 0 = Standard MII Mode 1 = Reduced MII Mode
4	RMII_REV1_0	0, RW	Reduce MII Revision 1.0: 0 = (RMII revision 1.2) CRS_DV will toggle at the end of a packet to indicate deassertion of CRS. 1 = (RMII revision 1.0) CRS_DV will remain asserted until final data is transferred. CRS_DV will not toggle at the end of a packet.
3	RX_OVF_STS	0, RO	RX FIFO Over Flow Status: 0 = Normal 1 = Overflow detected
2	RX_UNF_STS	0, RO	RX FIFO Under Flow Status: 0 = Normal 1 = Underflow detected
1:0	ELAST_BUF[1:0]	1, RW	Receive Elasticity Buffer. This field controls the Receive Elasticity Buffer which allows for frequency variation tolerance between the 50-MHz RMII clock and the recovered data. The following value indicate the tolerance in bits for a single packet. The minimum setting allows for standard Ethernet frame sizes at ± 50 ppm accuracy for both RMII and Receive clocks. For greater frequency tolerance the packet lengths may be scaled (that is, for ± 100 ppm, the packet lengths need to be divided by 2). 00 = 14 bit tolerance (up to 16800 byte packets) 01 = 2 bit tolerance (up to 2400 byte packets) 10 = 6 bit tolerance (up to 7200 byte packets) 11 = 10 bit tolerance (up to 12000 byte packets)

6.6.1.2.6 LED Direct Control Register (LEDCR)

This register provides the ability to directly control the LED outputs. It does not provide read access to the LEDs.

Table 6-23. LED Direct Control Register (LEDCR), address 0x18

Bit	Bit Name	Default	Description
15:6	RESERVED	0, RO	RESERVED: Writes ignored, read as 0.
5 ⁽¹⁾	DRV_SPDLED	0, RW	1 = Drive value of SPDLED bit onto LED_SPEED output 0 = Normal operation
4	DRV_LNKLED	0, RW	1 = Drive value of LNKLED bit onto LED_LINK output 0 = Normal operation
3	RESERVED	0	RESERVED: Must be zero.
2 ⁽¹⁾	SPDLED	0, RW	Value to force on LED_SPEED output
1	LNKLED	0, RW	Value to force on LED_LINK output
0	RESERVED	0	RESERVED: Must be zero.

(1) DP83848J/K only.

6.6.1.2.7 PHY Control Register (PHYCR)
Table 6-24. PHY Control Register (PHYCR), address 0x19

Bit	Bit Name	Default	Description						
15	MDIX_EN	Strap, RW	<p>Auto-MDIX Enable: 1 = Enable Auto-neg Auto-MDIX capability. 0 = Disable Auto-neg Auto-MDIX capability.</p> <p>The Auto-MDIX algorithm requires that the Auto-Negotiation Enable bit in the BMCR register to be set. If Auto-Negotiation is not enabled, Auto-MDIX should be disabled as well.</p>						
14	FORCE_MDIX	0, RW	<p>Force MDIX: 1 = Force MDI pairs to cross. (Receive on TPTD pair, Transmit on TPRD pair) 0 = Normal operation.</p>						
13	PAUSE_RX	0, RO	<p>Pause Receive Negotiated:</p> <p>Indicates that pause receive should be enabled in the MAC. Based on ANAR[11:10] and ANLPAR[11:10] settings.</p> <p>This function shall be enabled according to IEEE 802.3 Annex 28B Table 28B-3, "Pause Resolution", only if the Auto-Negotiated Highest Common Denominator is a full duplex technology.</p>						
12	PAUSE_TX	0, RO	<p>Pause Transmit Negotiated:</p> <p>Indicates that pause transmit should be enabled in the MAC. Based on ANAR[11:10] and ANLPAR[11:10] settings.</p> <p>This function shall be enabled according to IEEE 802.3 Annex 28B Table 28B-3, "Pause Resolution", only if the Auto-Negotiated Highest Common Denominator is a full duplex technology.</p>						
11	BIST_FE	0, RW/SC	<p>BIST Force Error: 1 = Force BIST Error. 0 = Normal operation.</p> <p>This bit forces a single error, and is self clearing.</p>						
10	PSR_15	0, RW	<p>BIST Sequence select: 1 = PSR15 selected. 0 = PSR9 selected.</p>						
9	BIST_STATUS	0, LL/RO	<p>BIST Test Status: 1 = BIST pass. 0 = BIST fail. Latched, cleared when BIST is stopped.</p> <p>For a count number of BIST errors, see the BIST Error Count in the CDCTRL1 register.</p>						
8	BIST_START	0, RW	<p>BIST Start: 1 = BIST start. 0 = BIST stop.</p>						
7	BP_STRETCH	0, RW	<p>Bypass LED Stretching:</p> <p>This will bypass the LED stretching and the LEDs will reflect the internal value. 1 = Bypass LED stretching. 0 = Normal operation.</p>						
6	RESERVED	0	RESERVED: Must be zero.						
5	LED_CNFG[0]	Strap, RW	<p>LED Configuration</p> <table border="1" style="margin-left: auto; margin-right: auto;"> <thead> <tr> <th>LED_CNFG[0]</th> <th>Mode Description</th> </tr> </thead> <tbody> <tr> <td>1</td> <td>Mode 1</td> </tr> <tr> <td>0</td> <td>Mode2</td> </tr> </tbody> </table> <p>In Mode 1, LEDs are configured as follows: LED_LINK = ON for Good Link, OFF for No Link LED_SPEED = ON in 100Mb/s, OFF in 10Mb/s</p> <p>In Mode 2, LEDs are configured as follows: LED_LINK = ON for good Link, BLINK for Activity LED_SPEED = ON in 100Mb/s, OFF in 10Mb/s</p>	LED_CNFG[0]	Mode Description	1	Mode 1	0	Mode2
LED_CNFG[0]	Mode Description								
1	Mode 1								
0	Mode2								
4:0	PHYADDR[4:0]	Strap, RW	PHY Address: PHY address for port.						

6.6.1.2.8 10BASE-T Status/Control Register (10BTSCR)

Table 6-25. 10BASE-T Status/Control Register (10BTSCR), address 0x1A

Bit	Bit Name	Default	Description
15	RESERVED	0, RW	RESERVED: Must be zero.
14:12	RESERVED	0, RW	RESERVED: Must be zero.
11:9	SQUELCH	100, RW	Squelch Configuration: Used to set the Squelch 'ON' threshold for the receiver. Default Squelch ON is 330-mV peak.
8	LOOPBACK_10_DIS	0, RW	In half-duplex mode, default 10BASE-T operation loops Transmit data to the Receive data in addition to transmitting the data on the physical medium. This is for consistency with earlier 10BASE2 and 10BASE5 implementations which used a shared medium. Setting this bit disables the loopback function. This bit does not affect loopback due to setting BMCR[14].
7	LP_DIS	0, RW	Normal Link Pulse Disable: 1 = Transmission of NLPs is disabled. 0 = Transmission of NLPs is enabled.
6	FORCE_LINK_10	0, RW	Force 10Mb Good Link: 1 = Forced Good 10 Mb Link. 0 = Normal Link Status.
5	RESERVED	0, RW	RESERVED: Must be zero.
4	POLARITY	RO/LH	10Mb Polarity Status: This bit is a duplication of bit 12 in the PHYSTS register. Both bits will be cleared upon a read of 10BTSCR register, but not upon a read of the PHYSTS register. 1 = Inverted Polarity detected. 0 = Correct Polarity detected.
3	RESERVED	0, RW	RESERVED: Must be zero.
2	RESERVED	1, RW	RESERVED: Must be set to one.
1	HEARTBEAT_DIS	0, RW	Heartbeat Disable: This bit only has influence in half-duplex 10Mb mode. 1 = Heartbeat function disabled. 0 = Heartbeat function enabled. When the device is operating at 100 Mb or configured for full duplex operation, this bit will be ignored - the heartbeat function is disabled.
0	JABBER_DIS	0, RW	Jabber Disable: Applicable only in 10BASE-T. 1 = Jabber function disabled. 0 = Jabber function enabled.

6.6.1.2.9 CD Test and BIST Extensions Register (CDCTRL1)

Table 6-26. CD Test and BIST Extensions Register (CDCTRL1), address 0x1B

Bit	Bit Name	Default	Description
15:8	BIST_ERROR_COUNT	0, RO	BIST ERROR Counter: Counts number of errored data nibbles during Packet BIST. This value will reset when Packet BIST is restarted. The counter sticks when it reaches its max count.
7:6	RESERVED	0, RW	RESERVED: Must be zero.
5	BIST_CONT_MODE	0, RW	Packet BIST Continuous Mode: Allows continuous pseudo random data transmission without any break in transmission. This can be used for transmit VOD testing. This is used in conjunction with the BIST controls in the PHYCR Register (0x19h). For 10 Mb operation, jabber function must be disabled, bit 0 of the 10BTSCR (0x1Ah), JABBER_DIS = 1.
4	CDPATTEN_10	0, RW	CD Pattern Enable for 10Mb: 1 = Enabled. 0 = Disabled.
3	RESERVED	0, RW	RESERVED: Must be zero.

Table 6-26. CD Test and BIST Extensions Register (CDCTRL1), address 0x1B (continued)

Bit	Bit Name	Default	Description
2	10MEG_PATT_GAP	0, RW	Defines gap between data or NLP test sequences: 1 = 15 μ s. 0 = 10 μ s.
1:0	CDPATTSEL[1:0]	00, RW	CD Pattern Select[1:0]: If CDPATTEN_10 = 1: 00 = Data, EOP0 sequence 01 = Data, EOP1 sequence 10 = NLPs 11 = Constant Manchester 1 s (10-MHz sine wave) for harmonic distortion testing.

6.6.1.2.10 Energy Detect Control (EDCR)

Table 6-27. Energy Detect Control (EDCR), address 0x1D

Bit	Bit Name	Default	Description
15	ED_EN	0, RW	Energy Detect Enable: Allow Energy Detect Mode. When Energy Detect is enabled and Auto-Negotiation is disabled through the BMCR register, Auto-MDIX should be disabled through the PHYCR register.
14	ED_AUTO_UP	1, RW	Energy Detect Automatic Power Up: Automatically begin power-up sequence when Energy Detect Data Threshold value (EDCR[3:0]) is reached. Alternatively, device could be powered up manually using the ED_MAN bit (EDCR[12]).
13	ED_AUTO_DOWN	1, RW	Energy Detect Automatic Power Down: Automatically begin power-down sequence when no energy is detected. Alternatively, device could be powered down using the ED_MAN bit (EDCR[12]).
12	ED_MAN	0, RW/SC	Energy Detect Manual Power Up/Down: Begin power-up/down sequence when this bit is asserted. When set, the Energy Detect algorithm will initiate a change of Energy Detect state regardless of threshold (error or data) and timer values.
11	ED_BURST_DIS	0, RW	Energy Detect Bust Disable: Disable bursting of energy detect data pulses. By default, Energy Detect (ED) transmits a burst of 4 ED data pulses each time the CD is powered up. When bursting is disabled, only a single ED data pulse will be send each time the CD is powered up.
10	ED_PWR_STATE	0, RO	Energy Detect Power State: Indicates current Energy Detect Power state. When set, Energy Detect is in the powered up state. When cleared, Energy Detect is in the powered down state. This bit is invalid when Energy Detect is not enabled.
9	ED_ERR_MET	0, RO/COR	Energy Detect Error Threshold Met: No action is automatically taken upon receipt of error events. This bit is informational only and would be cleared on a read.
8	ED_DATA_MET	0, RO/COR	Energy Detect Data Threshold Met: The number of data events that occurred met or surpassed the Energy Detect Data Threshold. This bit is cleared on a read.
7:4	ED_ERR_COUNT	0001, RW	Energy Detect Error Threshold: Threshold to determine the number of energy detect error events that should cause the device to take action. Intended to allow averaging of noise that may be on the line. Counter will reset after approximately 2 seconds without any energy detect data events.
3:0	ED_DATA_COUNT	0001, RW	Energy Detect Data Threshold: Threshold to determine the number of energy detect events that should cause the device to take actions. Intended to allow averaging of noise that may be on the line. Counter will reset after approximately 2 seconds without any energy detect data events.

7 Application, Implementation, and Layout

NOTE

Information in the following applications sections is not part of the TI component specification, and TI does not warrant its accuracy or completeness. TI's customers are responsible for determining suitability of components for their purposes. Customers should validate and test their design implementation to confirm system functionality.

7.1 Application Information

The device is a physical layer Ethernet transceiver. Typical operating voltage is 3.3 V with power consumption less than 270 mW. When using the device for Ethernet application, it is necessary to meet certain requirements for normal operation of device. Following typical application and design requirements can be used for selecting appropriate component values for DP83848.

7.2 Typical Application

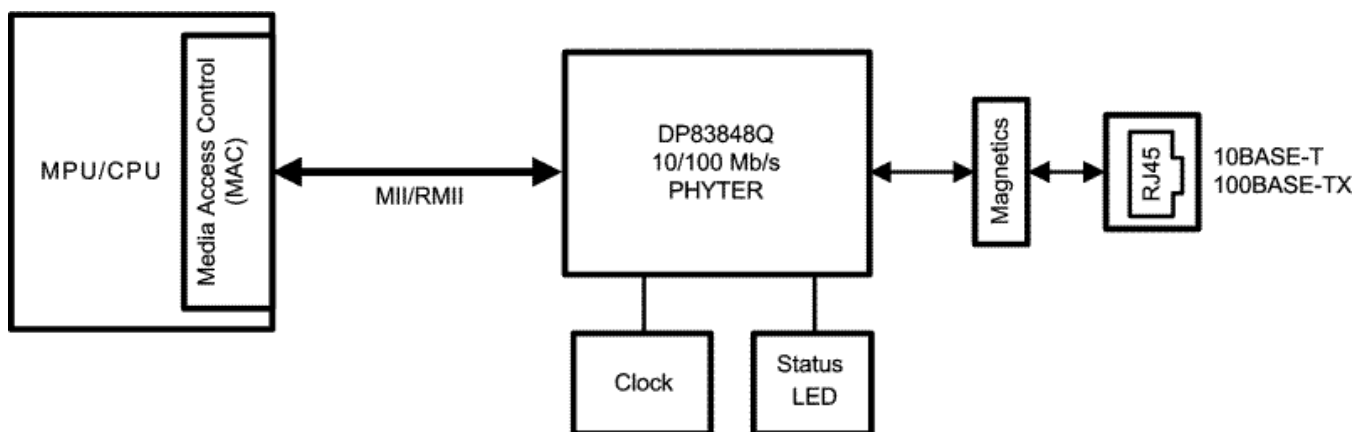

Figure 7-1. Typical Application Schematic

7.2.1 Design Requirements

The design requirements for DP83848 are:

- $V_{IN} = 3.3 \text{ V}$
- $V_{OUT} = V_{CC} - 0.5 \text{ V}$
- Clock Input = 25 MHz for MII and 50 MHz for RMII

7.2.1.1 TPI Network Circuit

Figure 7-2 shows the recommended circuit for a 10/100 Mb/s twisted pair interface. Below is a partial list of recommended transformers. It is important that the user realize that variations with PCB and component characteristics require that the application be tested to ensure that the circuit meets the requirements of the intended application.

- Pulse H1102
- Pulse H2019
- Pulse J0011D21
- Pulse J0011D21B

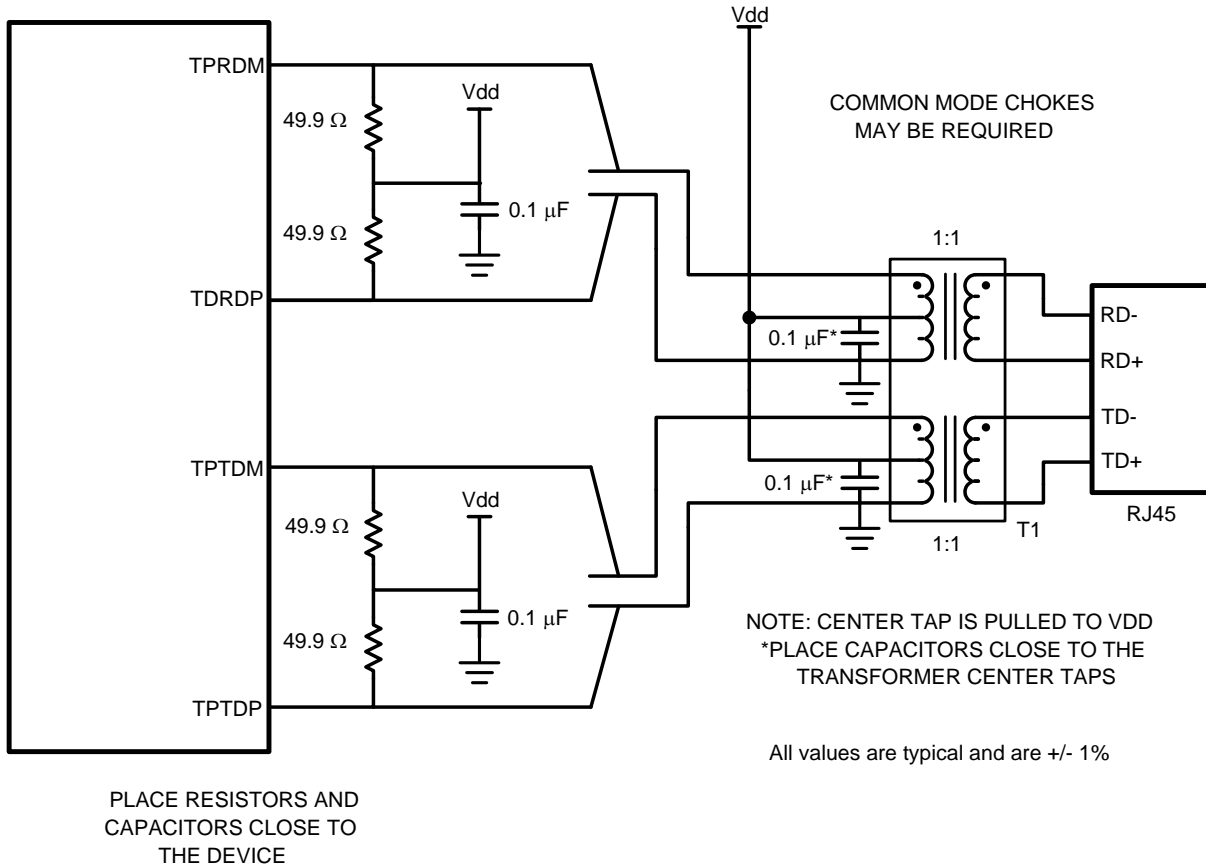

Figure 7-2. 10/100 Mb/s Twisted Pair Interface

7.2.1.2 Clock IN (X1) Recommendations

The DP83848x supports an external CMOS level oscillator source or a crystal resonator device.

7.2.1.2.1 Oscillator

If an external clock source is used, X1 should be tied to the clock source and X2 should be left floating.

The CMOS oscillator specifications for MII Mode are listed in [Table 7-1](#). For RMII Mode, the CMOS oscillator specifications are listed in [Table 7-2](#). For RMII mode, it is not recommended that the system clock out, Pin 21 of DP83848H, DP83848M, or DP83848T devices, be used as the reference clock to the MAC without first verifying the interface timing. See AN-1405 for more details.

7.2.1.2.2 Crystal

A 25-MHz, parallel, 20-pF load crystal resonator should be used if a crystal source is desired. [Figure 7-3](#) shows a typical connection for a crystal resonator circuit. The load capacitor values will vary with the crystal vendors; check with the vendor for the recommended loads.

The oscillator circuit is designed to drive a parallel resonance AT cut crystal with a minimum drive level of 100 μW and a maximum of 500 μW. If a crystal is specified for a lower drive level, a current limiting resistor should be placed in series between X2 and the crystal.

As a starting point for evaluating an oscillator circuit, if the requirements for the crystal are not known, CL1 and CL2 should be set at 33 pF, and R1 should be set at 0 Ω.

Specification for 25-MHz crystal are listed in [Table 7-3](#).

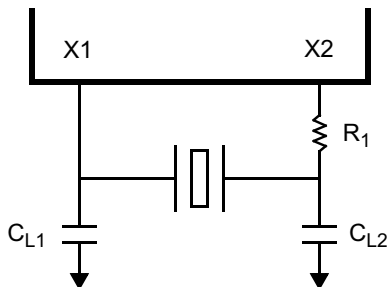

Figure 7-3. Crystal Oscillator Circuit

Table 7-1. 25-MHz Oscillator Specification

PARAMETER	CONDITION	MIN	TYP	MAX	UNIT
Frequency			25		MHz
Frequency Tolerance	Operational Temperature			50	ppm
Frequency Stability	1 year aging			50	ppm
Rise / Fall Time	20%–80%			6	nsec
Jitter	Short term			800 ⁽¹⁾	psec
Jitter	Long term			800 ⁽¹⁾	psec
Symmetry	Duty Cycle	40%		60%	

(1) This limit is provided as a guideline for component selection and **not** guaranteed by production testing. Refer to [SNLA076](#), *PHYTER 100 Base-TX Reference Clock Jitter Tolerance*, for details on jitter performance.

Table 7-2. 50-MHz Oscillator Specification

PARAMETER	CONDITION	MIN	TYP	MAX	UNIT
Frequency			50		MHz
Frequency Tolerance	Operational Temperature			50	ppm
Frequency Stability	1 year aging			50	ppm
Rise / Fall Time	20%–80%			6	nsec
Jitter	Short term			800 ⁽¹⁾	psec
Jitter	Long term			800 ⁽¹⁾	psec
Symmetry	Duty Cycle	40%		60%	

(1) This limit is provided as a guideline for component selection and **not** guaranteed by production testing. Refer to [SNLA076](#), *PHYTER 100 Base-TX Reference Clock Jitter Tolerance*, for details on jitter performance.

Table 7-3. 25-MHz Crystal Specification

PARAMETER	CONDITION	MIN	TYP	MAX	UNIT
Frequency			25		MHz
Frequency Tolerance	Operational Temperature			50	ppm
Frequency Stability	1 year aging			50	ppm
Load Capacitance		25		40	pF

7.2.1.3 Power Feedback Circuit

To ensure correct operation for the DP83848x, parallel caps with values of 10 μF (Tantalum) and 0.1 μF should be placed close to pin 19 (PFBOUT) of the device.

Pin 16 (PFBIN1) and pin 30 (PFBIN2) must be connected to pin 19 (PFBOUT), each pin requires a small capacitor (0.1 μF). See [Figure 7-4](#) for proper connections.

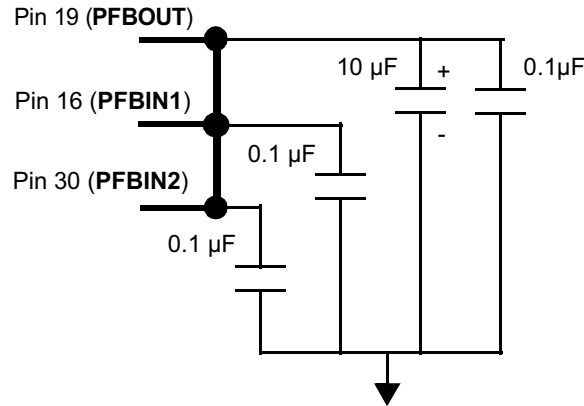

Figure 7-4. Power Feedback Connection

7.2.1.4 Magnetics

The magnetics have a large impact on the PHY performance as well. While several components are listed below, others may be compatible following the requirements listed in Table 6-4. It is recommended that the magnetics include both an isolation transformer and an integrated common mode choke to reduce EMI. When doing the layout, do not run signals under the magnetics. This could cause unwanted noise crosstalk. Likewise void the planes under discrete magnetics, this will help prevent common mode noise coupling. To save board space and reduce component count, an RJ-45 with integrated magnetics may be used.

Table 7-4. Magnetics Requirements

PARAMETER	TYP	UNITS	CONDITION
Turn Ratio	1:1	—	±2%
Insertion Loss	-1	dB	1-100 MHz
Return Loss	-16	dB	1-30 MHz
	-12	dB	30-60 MHz
	10	dB	60-80 MHz
Differential to Common Rejection Ratio	-30	dB	1-50MHz
	-20	dB	50-150 MHz
Crosstalk	-35	dB	30 MHz
	-30	dB	60 MHz
Isolation	1,500	dB	HPOT

7.2.2 Detailed Design Procedure

7.2.2.1 MAC Interface (MII/RMII)

The Media Independent Interface (MII) connects the PHYTER component to the Media Access Controller (MAC). The MAC may in fact be a discrete device, integrated into a microprocessor, CPU or FPGA. On the MII signals, the IEEE specification states the bus should be 68-Ω impedance. For space critical designs, the PHYTER family of products also support Reduced MII (RMII). For additional information on this mode of operation, refer to the *AN-1405 DP83848 Single 10/100 Mb/s Ethernet Transceiver Reduced Media Independent Interface (RMII) Mode Application Report (SNLA076)*.

7.2.2.1.1 Termination Requirement

To reduce digital signal energy, 50-Ω series termination resistors are recommended for all MII output signals (including RXCLK, TXCLK, and RX Data signals.)

7.2.2.1.2 Recommended Maximum Trace Length

Although RMII and MII are synchronous bus architectures, there are a number of factors limiting signal trace lengths. With a longer trace, the signal becomes more attenuated at the destination and thus more susceptible to noise interference. Longer traces also act as antennas, and if run on the surface layer, can increase EMI radiation. If a long trace is running near and adjacent to a noisy signal, the unwanted signals could be coupled in as cross talk. It is recommended to keep the signal trace lengths as short as possible. Ideally, keep the traces under 6 inches. Trace length matching, to within 2 inches on the MII or RMII bus is also recommended. Significant differences in the trace lengths can cause data timing issues. As with any high speed data signal, good design practices dictate that impedance should be maintained and stubs should be avoided throughout the entire data path.

7.2.2.2 Calculating Impedance

The following equations can be used to calculate the differential impedance of the board. For microstrip traces, a solid ground plane is needed under the signal traces. The ground plane helps keep the EMI localized and the trace impedance continuous. Because stripline traces are typically sandwiched between the ground/supply planes, they have the advantage of lower EMI radiation and less noise coupling. The trade off of using strip line is lower propagation speed.

7.2.2.2.1 Microstrip Impedance – Single-Ended

$$Z_0 = \left(\frac{87}{\sqrt{E_r + (1.41)}} \right) \ln \left(5.98 \frac{H}{0.8 W + T} \right) \quad (3)$$

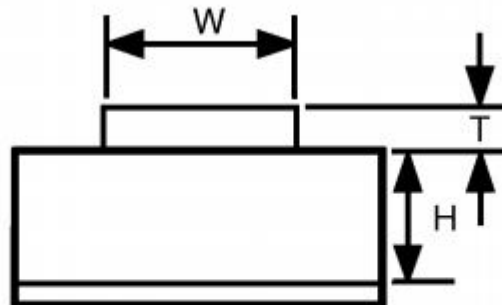

W = Width of the trace H = Height of dielectric above the return plane T = Trace thickness Er = Relative permittivity of the dielectric

Figure 7-5. Microstrip Impedance – Single-Ended

7.2.2.2.2 Stripline Impedance – Single-Ended

$$Z_o = \left(\frac{60}{\sqrt{E_r}} \right) \ln \left(1.98 \times \left(\frac{2 \times H + T}{0.8 \times W + T} \right) \right) \tag{4}$$

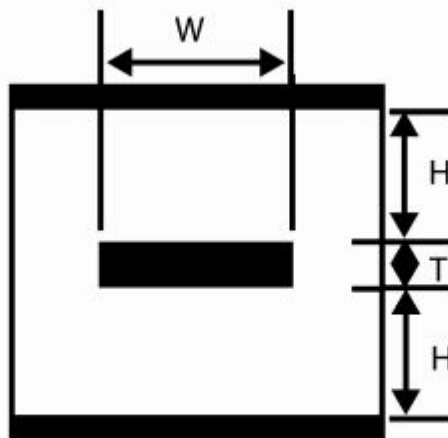

W = Width of the trace H = Height of dielectric above the return plane T = Trace thickness Er = Relative permittivity of the dielectric

Figure 7-6. Stripline Impedance – Single-Ended

7.2.2.2.3 Microstrip Impedance – Differential

$$Z_{diff} = 2 \times Z_o \times \left(1 - 0.48 \left(e^{(-0.96 \frac{S}{H})} \right) \right) \tag{5}$$

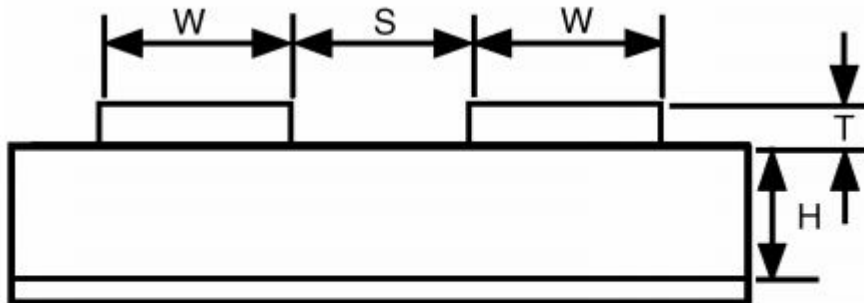

W = Width of the trace H = Height of dielectric above the return plane T = Trace thickness S = Space between traces Er = Relative permittivity of the dielectric

Figure 7-7. Microstrip Impedance – Differential

7.2.2.2.4 Stripline Impedance – Differential

$$Z_{diff} = 2 \times Z_o \left(1 - 0.347 \left(e^{(-2.9 \frac{S}{H})} \right) \right)$$

(6)

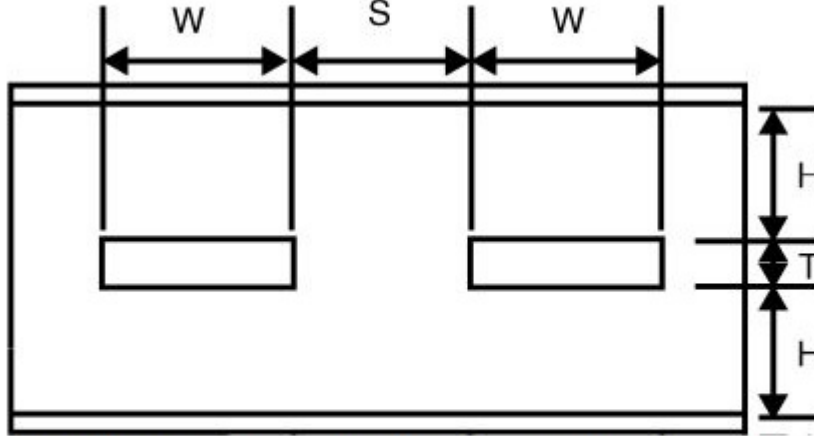

W = Width of the trace H = Height of dielectric above the return plane T = Trace thickness S = space between traces
 Er = Relative permittivity of the dielectric

Figure 7-8. Stripline Impedance – Differential

7.2.3 Application Curves

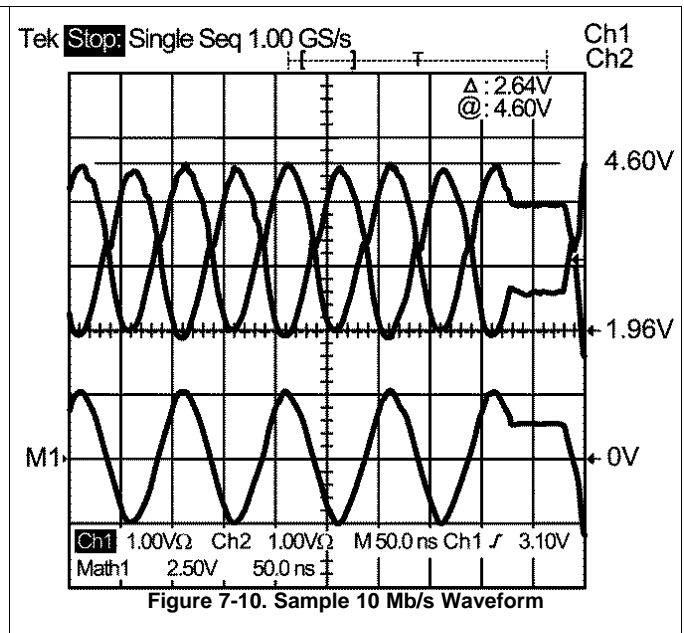
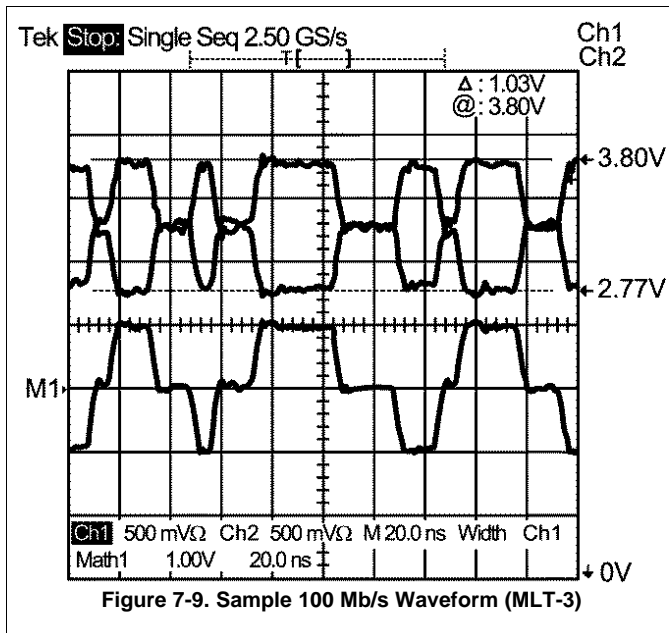

7.3 Layout

7.3.1 Layout Guidelines

Place the 49.9- Ω , 1% resistors, and 0.1- μ F decoupling capacitor near the PHYTER TD+/- and RD+/- pins and via directly to the V_{DD} plane.

Stubs should be avoided on all signal traces, especially the differential signal pairs. See [Figure 7-11](#). Within the pairs (for example, TD+ and TD-) the trace lengths should be run parallel to each other and matched in length. Matched lengths minimize delay differences, avoiding an increase in common mode noise and increased EMI. See [Figure 7-11](#).

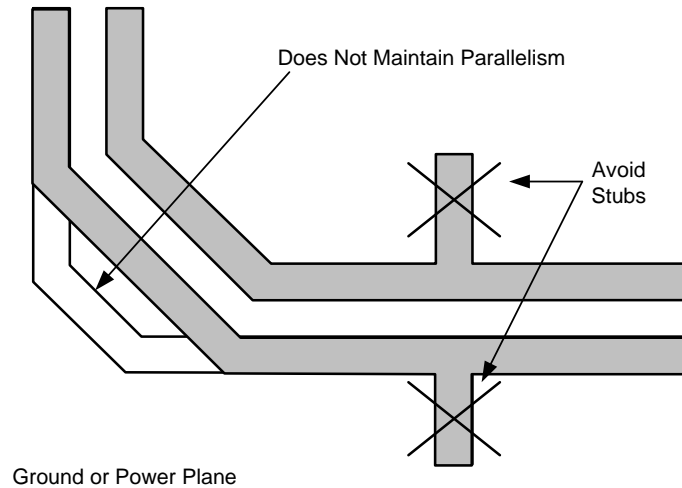

Figure 7-11. Differential Signal Pair - Stubs

Ideally, there should be no crossover or via on the signal paths. Vias present impedance discontinuities and should be minimized. Route an entire trace pair on a single layer if possible. PCB trace lengths should be kept as short as possible.

Signal traces should not be run such that they cross a plane split. See [Figure 7-12](#). A signal crossing a plane split may cause unpredictable return path currents and would likely impact signal quality as well, potentially creating EMI problems.

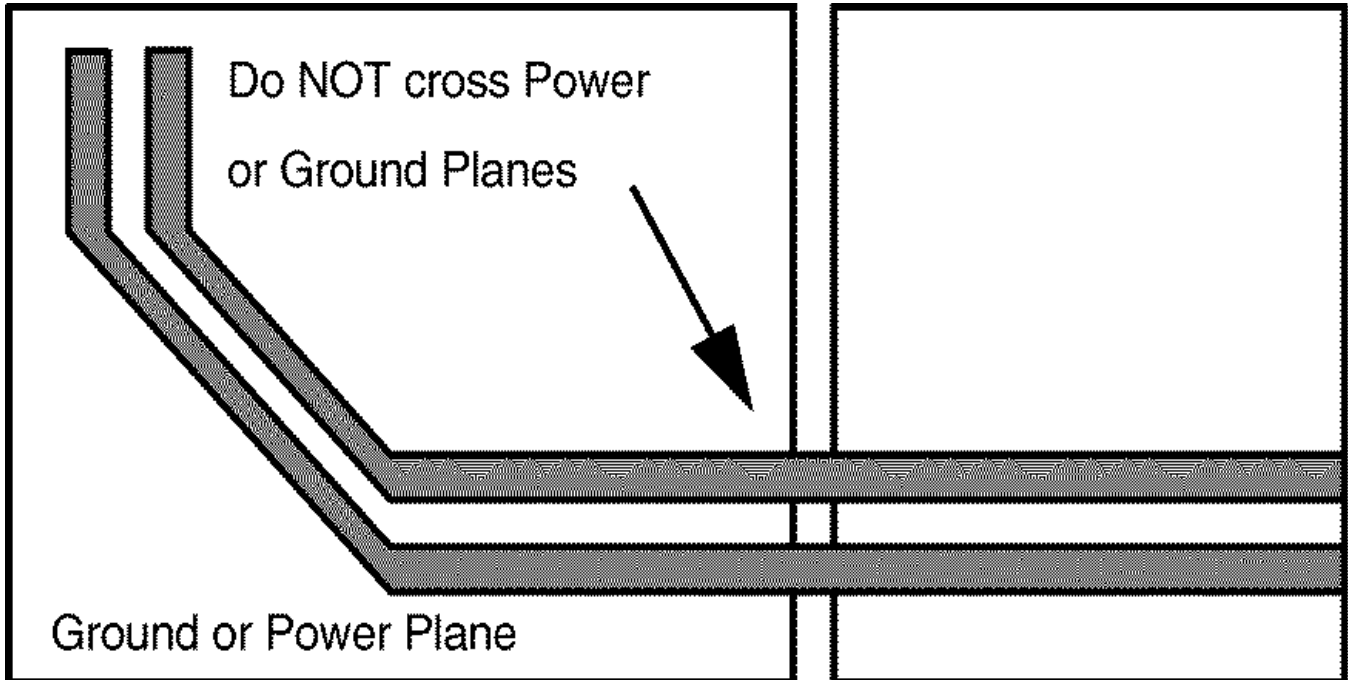

Figure 7-12. Differential Signal Pair-Plane Crossing

MDI signal traces should have 50 Ω to ground or 100- Ω differential controlled impedance. Many tools are available online to calculate this.

7.3.1.1 PCB Layer Stacking

To meet signal integrity and performance requirements, at minimum a 4-layer PCB is recommended for implementing PHYTER components in end user systems. The following layer stack-ups are recommended for four, six, and eight-layer boards, although other options are possible.

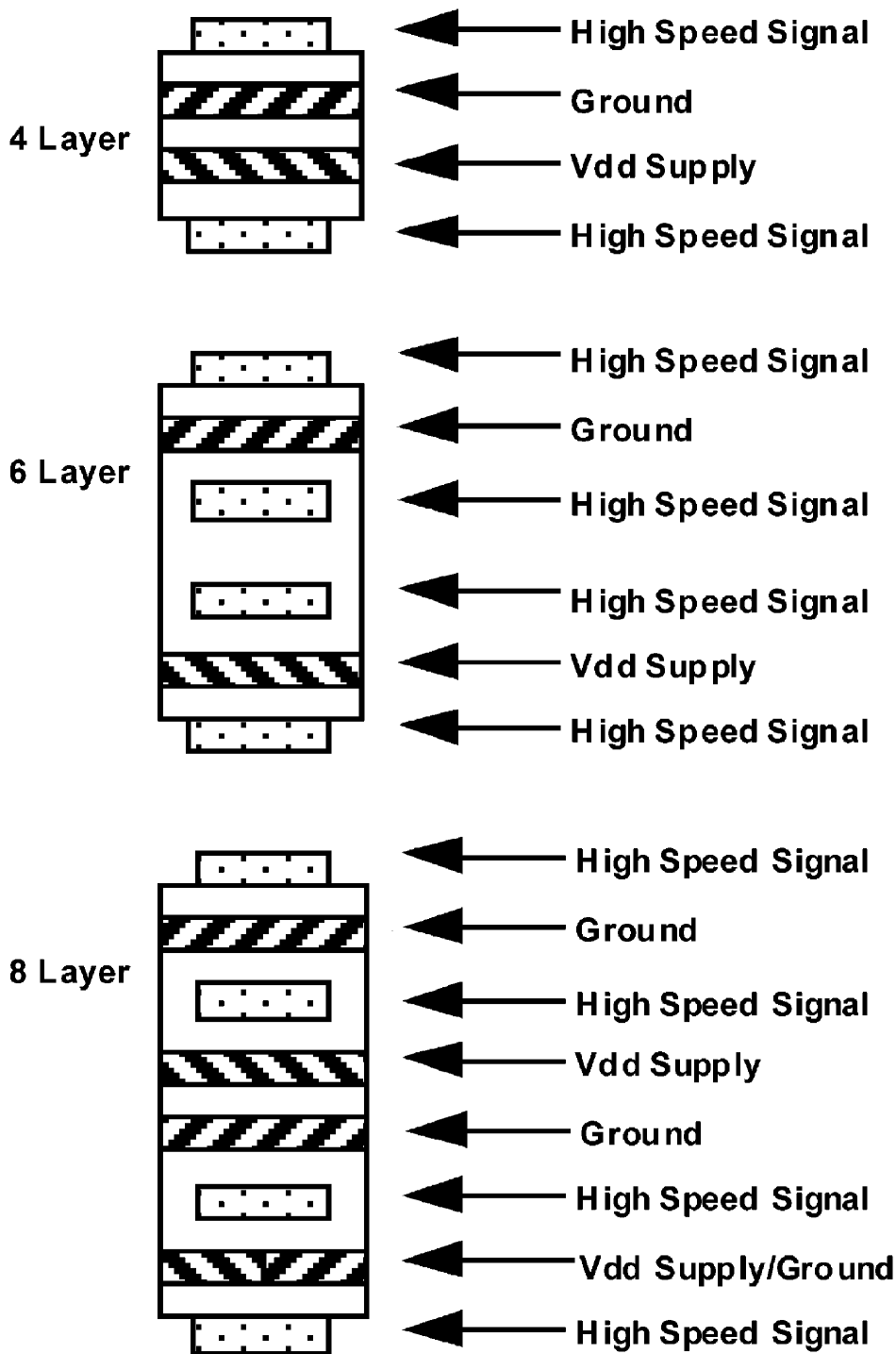

Figure 7-13. PCB Stripline Layer Stacking

Within a PCB it may be desirable to run traces using different methods, microstrip vs. stripline, depending on the location of the signal on the PCB. For example, it may be desirable to change layer stacking where an isolated chassis ground plane is used. **Figure 7-14** illustrates alternative PCB stacking options.

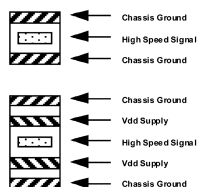

Figure 7-14. Alternative PCB Stripline Layer Stacking

7.3.2 Layout Example

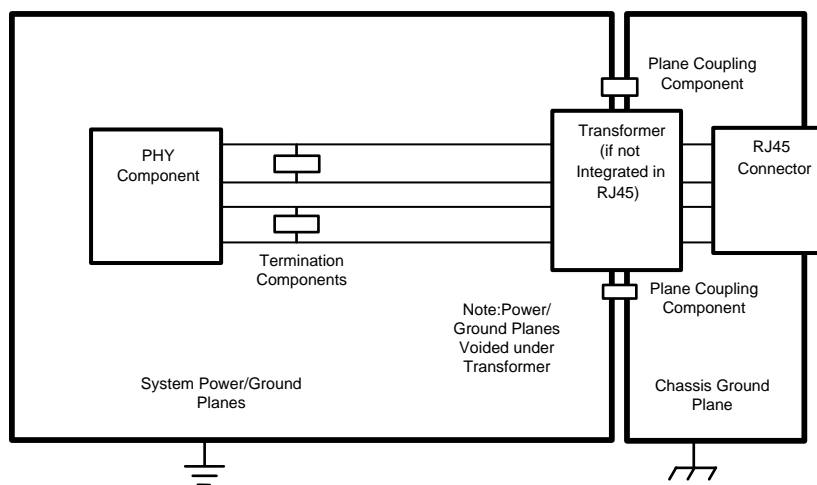

Figure 7-15. Layout Example

7.4 Power Supply Recommendations

The device V_{DD} supply pins should be bypassed with low-impedance 0.1- μF surface mount capacitors. To reduce EMI, the capacitors should be placed as close as possible to the component V_{DD} supply pins, preferably between the supply pins and the vias connecting to the power plane. In some systems it may be desirable to add 0- Ω resistors in series with supply pins, as the resistor pads provide flexibility if adding EMI beads becomes necessary to meet system level certification testing requirements. (See [Figure 7-14](#)) It is recommended the PCB have at least one solid ground plane and one solid V_{DD} plane to provide a low impedance power source to the component. This also provides a low impedance return path for non-differential digital MII and clock signals. A 10.0- μF capacitor should also be placed near the PHY component for local bulk bypassing between the V_{DD} and ground planes.

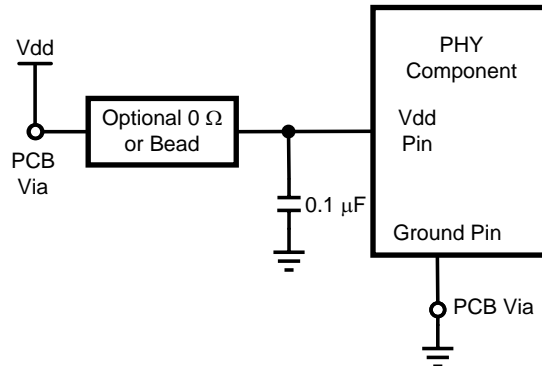

Figure 7-16. V_{DD} Bypass Layout

8 Device and Documentation Support

8.1 Documentation Support

8.1.1 Related Documentation

For related documentation see the following:

- *AN-1405 DP83848 Single 10/100 Mb/s Ethernet Transceiver Reduced Media Independent Interface (RMII) Mode Application Report*, [SNLA076](#)
- *AN-1540 Power Measurement of Ethernet Physical Layer Products*, [SNLA089](#)
- *AN-1548 PHYTER 100 Base-TX Reference Clock Jitter Tolerance*, [SNLA091](#)

8.2 Related Links

The table below lists quick access links. Categories include technical documents, support and community resources, tools and software, and quick access to sample or buy.

Table 8-1. Related Links

PARTS	PRODUCT FOLDER	SAMPLE & BUY	TECHNICAL DOCUMENTS	TOOLS & SOFTWARE	SUPPORT & COMMUNITY
DP83848H	Click here	Click here	Click here	Click here	Click here
DP83848J	Click here	Click here	Click here	Click here	Click here
DP83848K	Click here	Click here	Click here	Click here	Click here
DP83848M	Click here	Click here	Click here	Click here	Click here
DP83848T	Click here	Click here	Click here	Click here	Click here

8.3 Trademarks

All trademarks are the property of their respective owners.

8.4 Electrostatic Discharge Caution



This integrated circuit can be damaged by ESD. Texas Instruments recommends that all integrated circuits be handled with appropriate precautions. Failure to observe proper handling and installation procedures can cause damage.

ESD damage can range from subtle performance degradation to complete device failure. Precision integrated circuits may be more susceptible to damage because very small parametric changes could cause the device not to meet its published specifications.

8.5 Glossary

[TI Glossary](#) This glossary lists and explains terms, acronyms, and definitions.

9 Mechanical Packaging and Orderable Information

The following pages include mechanical, packaging, and orderable information. This information is the most current data available for the designated devices. This data is subject to change without notice and revision of this document. For browser-based versions of this data sheet, refer to the left-hand navigation.

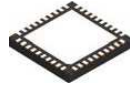

PACKAGE OUTLINE

RTA0040A

WQFN - 0.8 mm max height

PLASTIC QUAD FLATPACK - NO LEAD

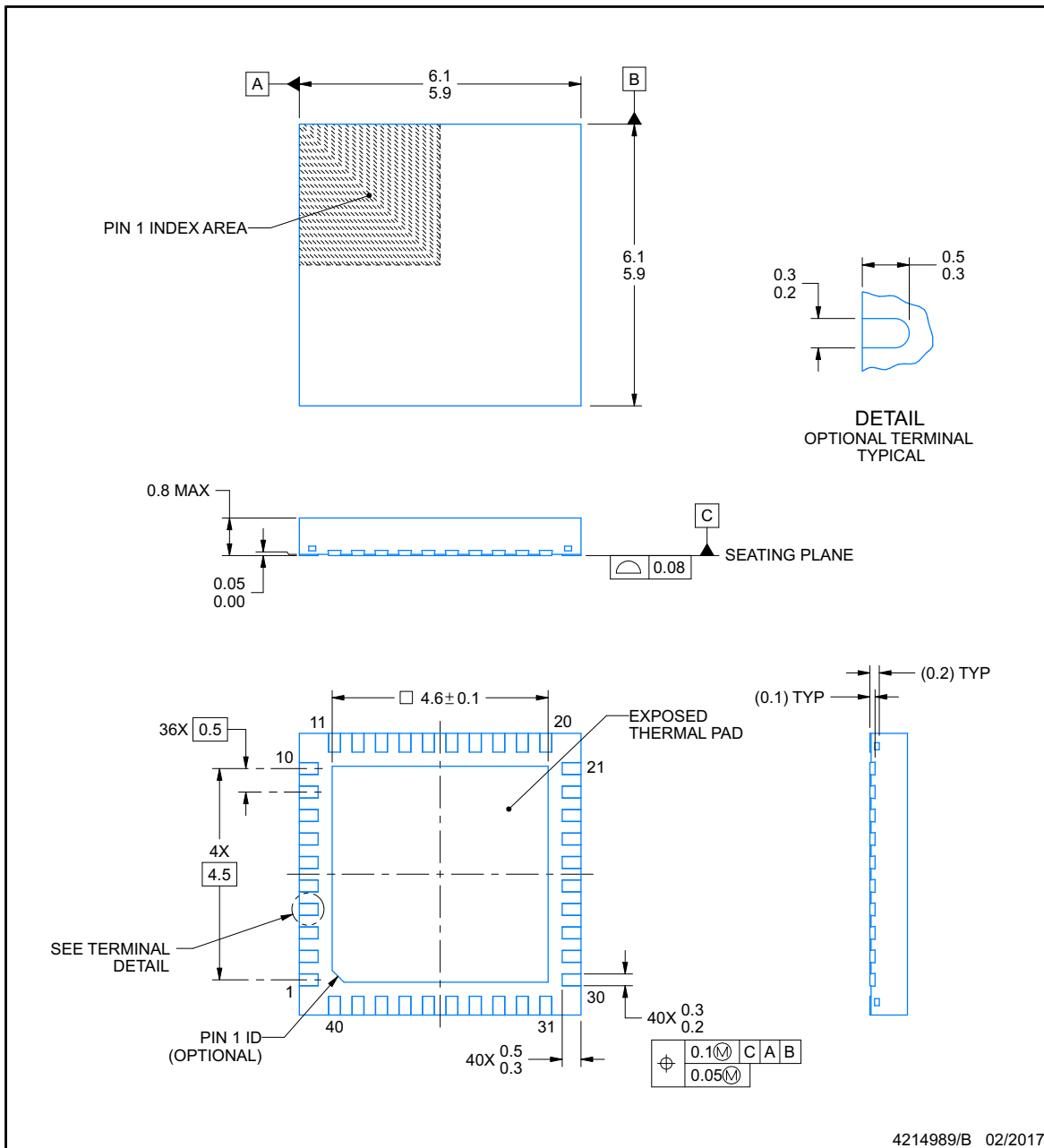

4214989/B 02/2017

NOTES:

1. All linear dimensions are in millimeters. Any dimensions in parenthesis are for reference only. Dimensioning and tolerancing per ASME Y14.5M.
2. This drawing is subject to change without notice.
3. The package thermal pad must be soldered to the printed circuit board for thermal and mechanical performance.

EXAMPLE BOARD LAYOUT

RTA0040A

WQFN - 0.8 mm max height

PLASTIC QUAD FLATPACK - NO LEAD

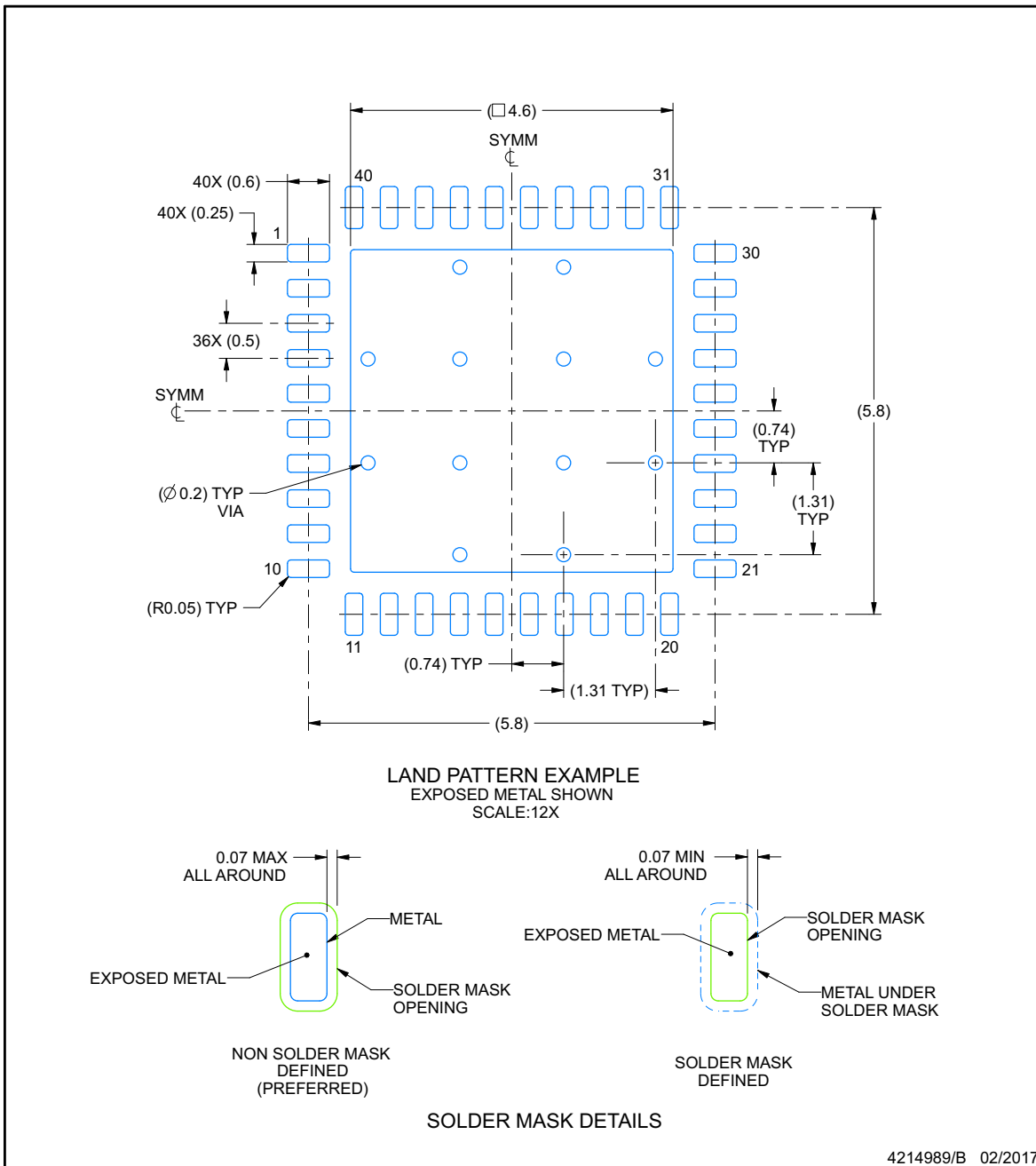

NOTES: (continued)

4. This package is designed to be soldered to a thermal pad on the board. For more information, see Texas Instruments literature number SLUA271 (www.ti.com/lit/sluea271).
5. Vias are optional depending on application, refer to device data sheet. If any vias are implemented, refer to their locations shown on this view. It is recommended that vias under paste be filled, plugged or tented.

www.ti.com

EXAMPLE STENCIL DESIGN

RTA0040A

WQFN - 0.8 mm max height

PLASTIC QUAD FLATPACK - NO LEAD

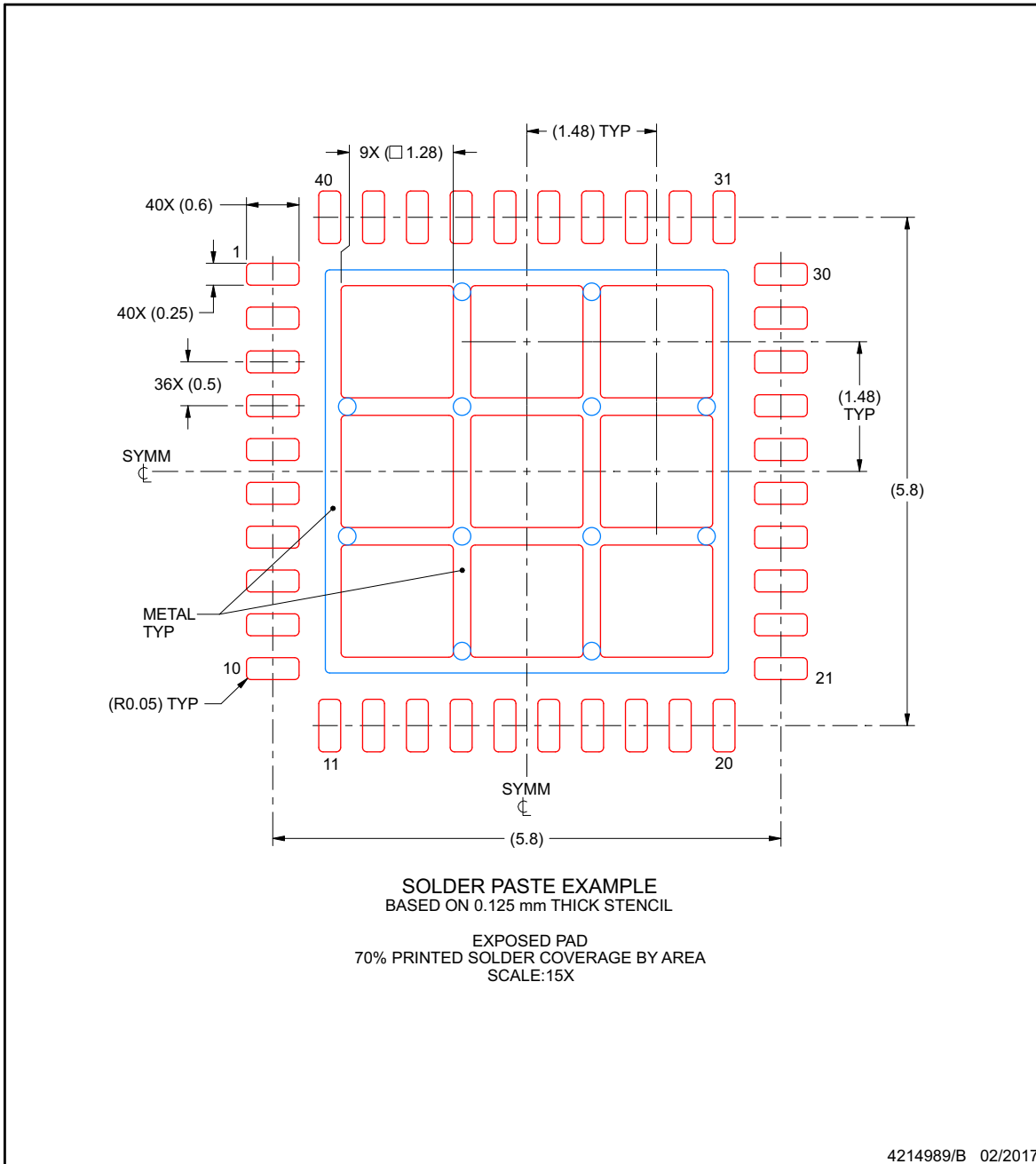

NOTES: (continued)

6. Laser cutting apertures with trapezoidal walls and rounded corners may offer better paste release. IPC-7525 may have alternate design recommendations.

PACKAGING INFORMATION

Orderable Device	Status (1)	Package Type	Package Drawing	Pins	Package Qty	Eco Plan (2)	Lead finish/ Ball material (6)	MSL Peak Temp (3)	Op Temp (°C)	Device Marking (4/5)	Samples
DP83848HSQ/NOPB	ACTIVE	WQFN	RTA	40	250	RoHS & Green	SN	Level-2-260C-1 YEAR	-40 to 125	83848HSQ	Samples
DP83848JSQ/NOPB	ACTIVE	WQFN	RTA	40	250	RoHS & Green	SN	Level-2-260C-1 YEAR	0 to 70	83848JSQ	Samples
DP83848KSQ/NOPB	ACTIVE	WQFN	RTA	40	250	RoHS & Green	SN	Level-2-260C-1 YEAR	-40 to 85	83848KSQ	Samples
DP83848MSQ/NOPB	ACTIVE	WQFN	RTA	40	250	RoHS & Green	SN	Level-2-260C-1 YEAR	0 to 70	83848MSQ	Samples
DP83848TSQ/NOPB	ACTIVE	WQFN	RTA	40	250	RoHS & Green	SN	Level-2-260C-1 YEAR	-40 to 85	83848TSQ	Samples

(1) The marketing status values are defined as follows:

ACTIVE: Product device recommended for new designs.

LIFEBUY: TI has announced that the device will be discontinued, and a lifetime-buy period is in effect.

NRND: Not recommended for new designs. Device is in production to support existing customers, but TI does not recommend using this part in a new design.

PREVIEW: Device has been announced but is not in production. Samples may or may not be available.

OBSOLETE: TI has discontinued the production of the device.

(2) **RoHS:** TI defines "RoHS" to mean semiconductor products that are compliant with the current EU RoHS requirements for all 10 RoHS substances, including the requirement that RoHS substance do not exceed 0.1% by weight in homogeneous materials. Where designed to be soldered at high temperatures, "RoHS" products are suitable for use in specified lead-free processes. TI may reference these types of products as "Pb-Free".

RoHS Exempt: TI defines "RoHS Exempt" to mean products that contain lead but are compliant with EU RoHS pursuant to a specific EU RoHS exemption.

Green: TI defines "Green" to mean the content of Chlorine (Cl) and Bromine (Br) based flame retardants meet JS709B low halogen requirements of <=1000ppm threshold. Antimony trioxide based flame retardants must also meet the <=1000ppm threshold requirement.

(3) MSL, Peak Temp. - The Moisture Sensitivity Level rating according to the JEDEC industry standard classifications, and peak solder temperature.

(4) There may be additional marking, which relates to the logo, the lot trace code information, or the environmental category on the device.

(5) Multiple Device Markings will be inside parentheses. Only one Device Marking contained in parentheses and separated by a "~" will appear on a device. If a line is indented then it is a continuation of the previous line and the two combined represent the entire Device Marking for that device.

(6) Lead finish/Ball material - Orderable Devices may have multiple material finish options. Finish options are separated by a vertical ruled line. Lead finish/Ball material values may wrap to two lines if the finish value exceeds the maximum column width.

Important Information and Disclaimer: The information provided on this page represents TI's knowledge and belief as of the date that it is provided. TI bases its knowledge and belief on information provided by third parties, and makes no representation or warranty as to the accuracy of such information. Efforts are underway to better integrate information from third parties. TI has taken and continues to take reasonable steps to provide representative and accurate information but may not have conducted destructive testing or chemical analysis on incoming materials and chemicals. TI and TI suppliers consider certain information to be proprietary, and thus CAS numbers and other limited information may not be available for release.

In no event shall TI's liability arising out of such information exceed the total purchase price of the TI part(s) at issue in this document sold by TI to Customer on an annual basis.

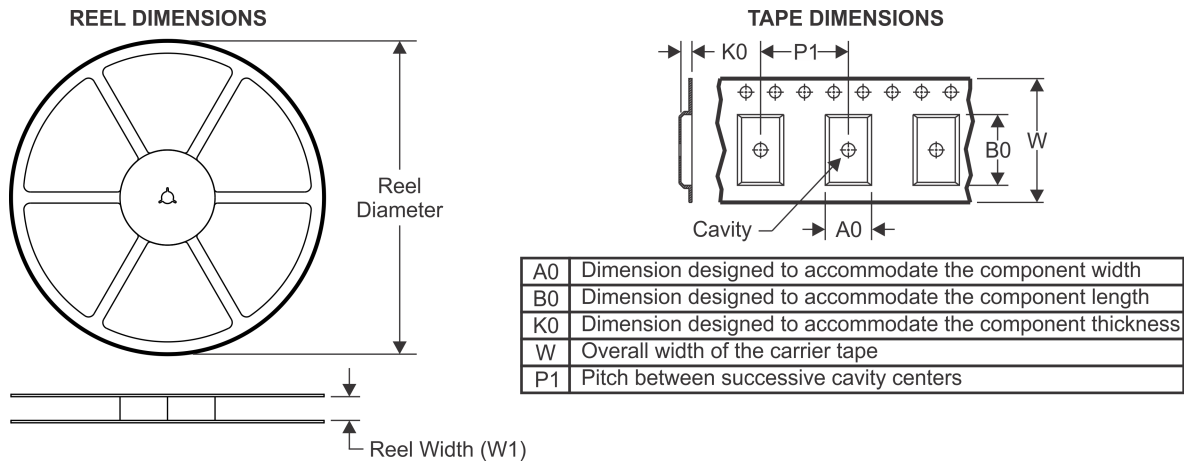
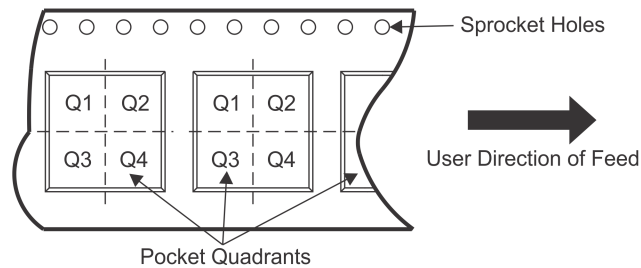
TAPE AND REEL INFORMATION

QUADRANT ASSIGNMENTS FOR PIN 1 ORIENTATION IN TAPE

*All dimensions are nominal

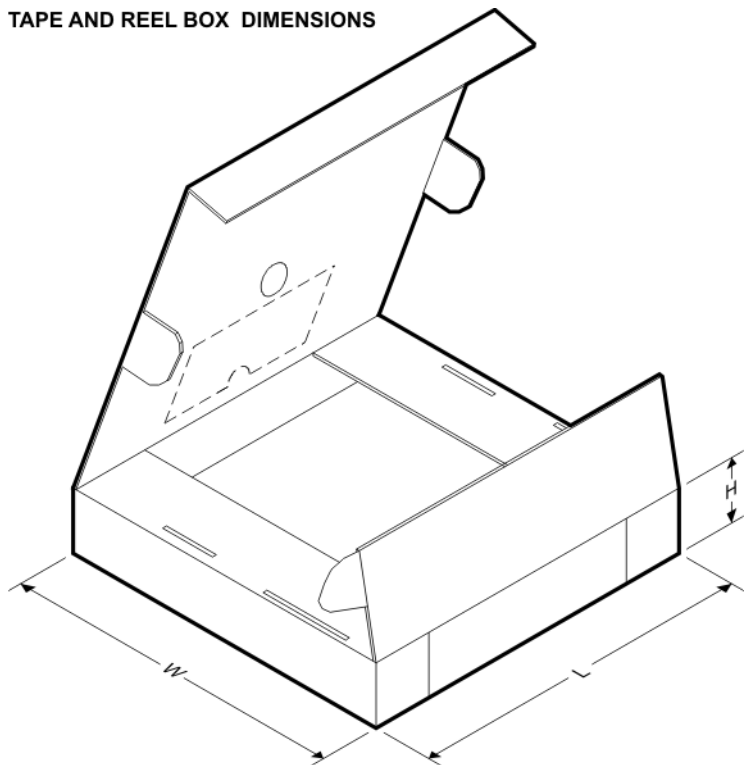
Device	Package Type	Package Drawing	Pins	SPQ	Reel Diameter (mm)	Reel Width W1 (mm)	A0 (mm)	B0 (mm)	K0 (mm)	P1 (mm)	W (mm)	Pin1 Quadrant
DP83848HSQ/NOPB	WQFN	RTA	40	250	178.0	16.4	6.3	6.3	1.5	12.0	16.0	Q1
DP83848JSQ/NOPB	WQFN	RTA	40	250	178.0	16.4	6.3	6.3	1.5	12.0	16.0	Q1
DP83848KSQ/NOPB	WQFN	RTA	40	250	178.0	16.4	6.3	6.3	1.5	12.0	16.0	Q1
DP83848MSQ/NOPB	WQFN	RTA	40	250	178.0	16.4	6.3	6.3	1.5	12.0	16.0	Q1
DP83848TSQ/NOPB	WQFN	RTA	40	250	178.0	16.4	6.3	6.3	1.5	12.0	16.0	Q1

TAPE AND REEL BOX DIMENSIONS

*All dimensions are nominal

Device	Package Type	Package Drawing	Pins	SPQ	Length (mm)	Width (mm)	Height (mm)
DP83848HSQ/NOPB	WQFN	RTA	40	250	208.0	191.0	35.0
DP83848JSQ/NOPB	WQFN	RTA	40	250	208.0	191.0	35.0
DP83848KSQ/NOPB	WQFN	RTA	40	250	208.0	191.0	35.0
DP83848MSQ/NOPB	WQFN	RTA	40	250	208.0	191.0	35.0
DP83848TSQ/NOPB	WQFN	RTA	40	250	208.0	191.0	35.0

RTA0040A

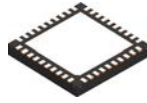

PACKAGE OUTLINE

WQFN - 0.8 mm max height

PLASTIC QUAD FLATPACK - NO LEAD

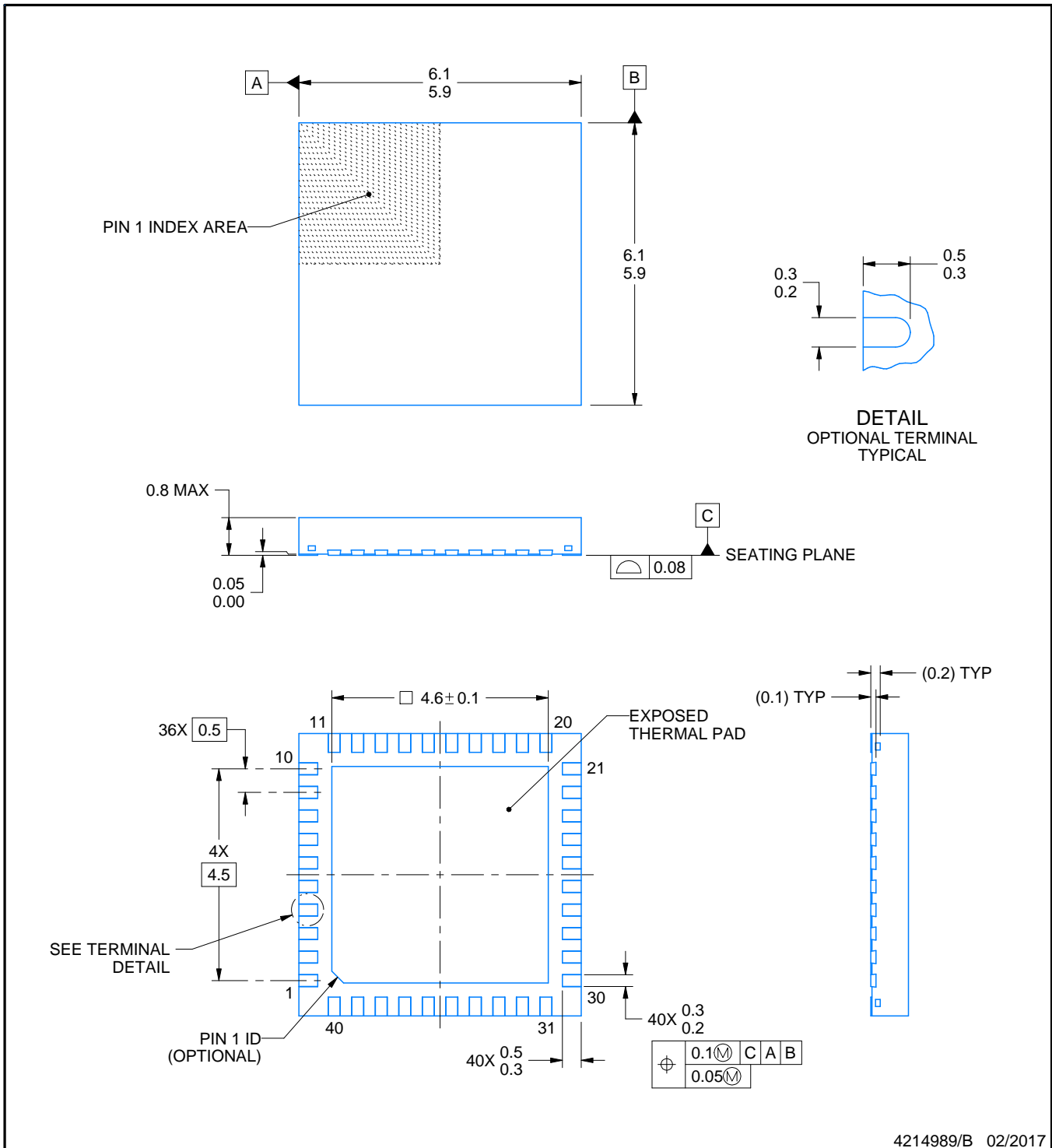

4214989/B 02/2017

NOTES:

1. All linear dimensions are in millimeters. Any dimensions in parenthesis are for reference only. Dimensioning and tolerancing per ASME Y14.5M.
2. This drawing is subject to change without notice.
3. The package thermal pad must be soldered to the printed circuit board for thermal and mechanical performance.

EXAMPLE BOARD LAYOUT

RTA0040A

WQFN - 0.8 mm max height

PLASTIC QUAD FLATPACK - NO LEAD

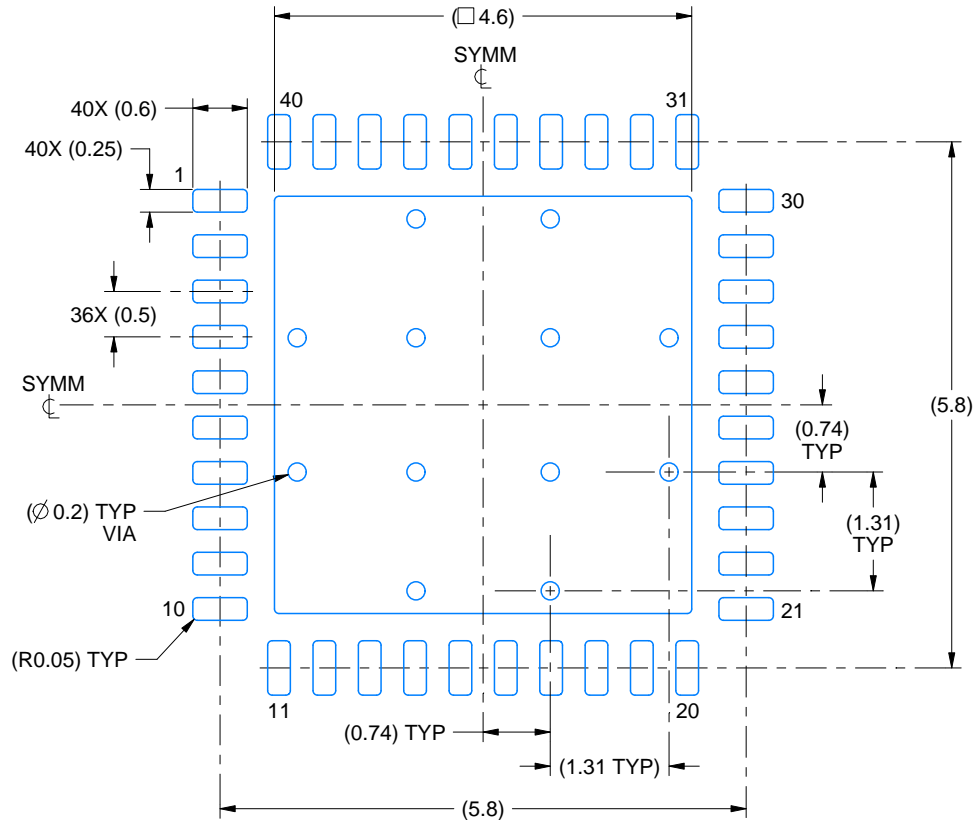

LAND PATTERN EXAMPLE
EXPOSED METAL SHOWN
SCALE:12X

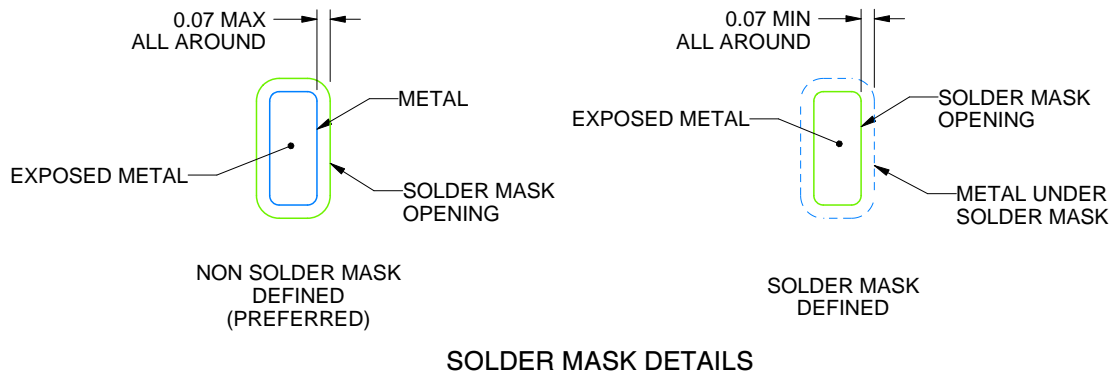

SOLDER MASK DETAILS

4214989/B 02/2017

NOTES: (continued)

- This package is designed to be soldered to a thermal pad on the board. For more information, see Texas Instruments literature number SLUA271 (www.ti.com/lit/slua271).
- Vias are optional depending on application, refer to device data sheet. If any vias are implemented, refer to their locations shown on this view. It is recommended that vias under paste be filled, plugged or tented.

EXAMPLE STENCIL DESIGN

RTA0040A

WQFN - 0.8 mm max height

PLASTIC QUAD FLATPACK - NO LEAD

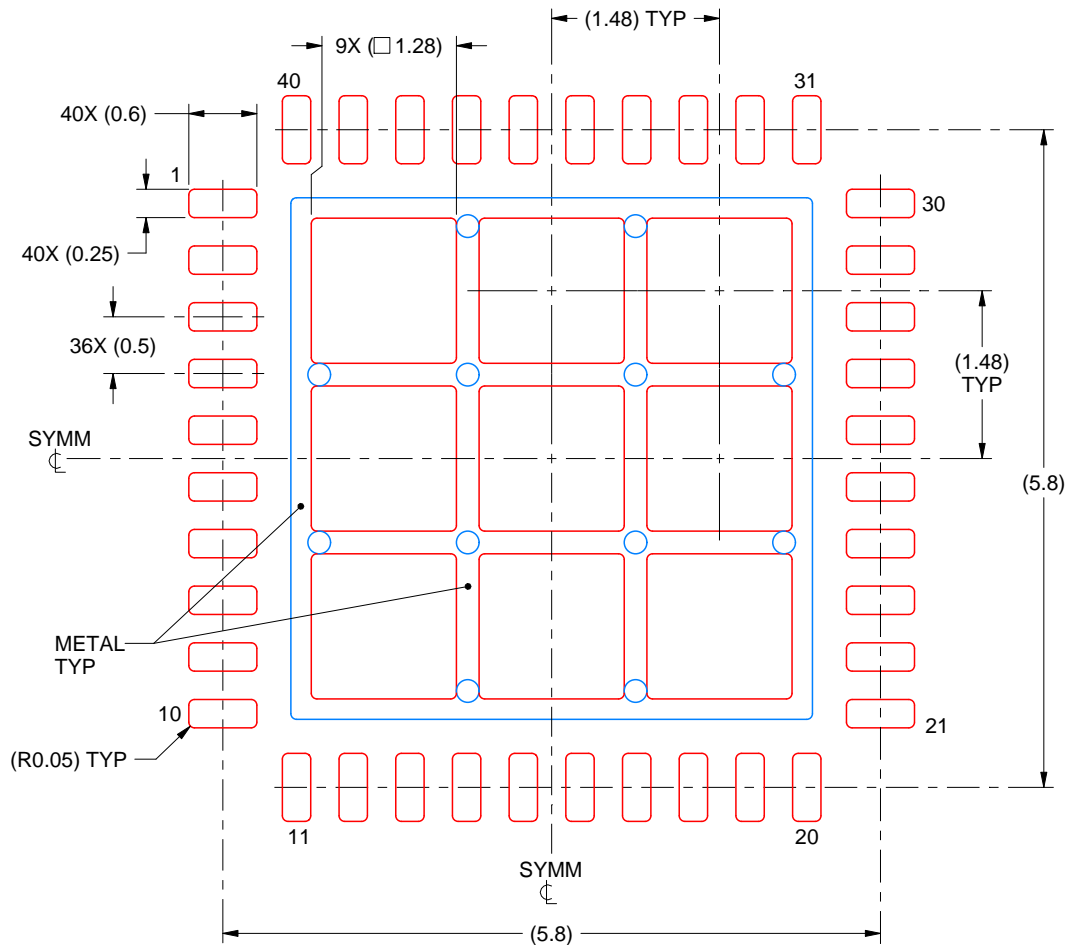

SOLDER PASTE EXAMPLE
BASED ON 0.125 mm THICK STENCIL

EXPOSED PAD
70% PRINTED SOLDER COVERAGE BY AREA
SCALE:15X

4214989/B 02/2017

NOTES: (continued)

6. Laser cutting apertures with trapezoidal walls and rounded corners may offer better paste release. IPC-7525 may have alternate design recommendations.

IMPORTANT NOTICE AND DISCLAIMER

TI PROVIDES TECHNICAL AND RELIABILITY DATA (INCLUDING DATA SHEETS), DESIGN RESOURCES (INCLUDING REFERENCE DESIGNS), APPLICATION OR OTHER DESIGN ADVICE, WEB TOOLS, SAFETY INFORMATION, AND OTHER RESOURCES "AS IS" AND WITH ALL FAULTS, AND DISCLAIMS ALL WARRANTIES, EXPRESS AND IMPLIED, INCLUDING WITHOUT LIMITATION ANY IMPLIED WARRANTIES OF MERCHANTABILITY, FITNESS FOR A PARTICULAR PURPOSE OR NON-INFRINGEMENT OF THIRD PARTY INTELLECTUAL PROPERTY RIGHTS.

These resources are intended for skilled developers designing with TI products. You are solely responsible for (1) selecting the appropriate TI products for your application, (2) designing, validating and testing your application, and (3) ensuring your application meets applicable standards, and any other safety, security, regulatory or other requirements.

These resources are subject to change without notice. TI grants you permission to use these resources only for development of an application that uses the TI products described in the resource. Other reproduction and display of these resources is prohibited. No license is granted to any other TI intellectual property right or to any third party intellectual property right. TI disclaims responsibility for, and you will fully indemnify TI and its representatives against, any claims, damages, costs, losses, and liabilities arising out of your use of these resources.

TI's products are provided subject to [TI's Terms of Sale](#) or other applicable terms available either on ti.com or provided in conjunction with such TI products. TI's provision of these resources does not expand or otherwise alter TI's applicable warranties or warranty disclaimers for TI products.

TI objects to and rejects any additional or different terms you may have proposed.

Mailing Address: Texas Instruments, Post Office Box 655303, Dallas, Texas 75265
Copyright © 2021, Texas Instruments Incorporated