

INA186-Q1 符合 AEC-Q100 标准且具有皮安级 IB 和使能引脚的 40V、双向、高精度电流感测放大器

1 特性

- 符合面向汽车应用的 AEC-Q100 标准：
 - 温度等级 1：-40°C 至 +125°C，T_A
- 提供功能安全
 - 有助于进行功能安全系统设计的文档
- 宽共模电压范围 V_{CM}：
 - 0.2V 至 +40V，可承受高达 42V 的电压（建议用于汽车类 12V 电池应用）
- 低输入偏置电流 I_{IB}：500 pA（典型值）
- 低功耗：
 - 低电源电压 V_S：1.7V 至 5.5V
 - 低静态电流 I_Q：48 μA（典型值）
- 精度：
 - 共模抑制比：120 dB（最小值）
 - 增益误差 E_G：±1%（最大值）
 - 增益漂移：10 ppm/°C（最大值）
 - 失调电压 V_{OS}：±50 μV（最大值）
 - 失调漂移：0.5 μV/°C（上限）
- 双向电流感测功能
- 增益选项：
 - INA186A1-Q1：25 V/V
 - INA186A2-Q1：50V/V
 - INA186A3-Q1：100V/V
 - INA186A4-Q1：200V/V
 - INA186A5-Q1：500V/V

2 应用

- 车身控制模块 (BCM)
- 远程信息处理控制单元
- 紧急呼叫 (eCall)
- 12V 电池管理系统 (BMS)
- 汽车音响主机

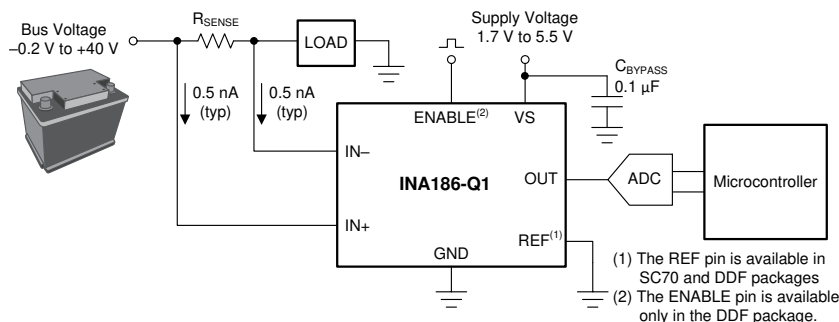

典型应用

3 说明

INA186-Q1 汽车类、低功耗电压输出电流感测放大器（也被称为电流分流监控器）。此器件常用于监控直接连接到汽车类 12V 电池的系统。INA186-Q1 可在独立于电源电压的 -0.2V 至 +40V 的共模电压下感测分流器上的压降。此外，输入引脚还具有 42V 的绝对最大电压。

INA186-Q1 的低输入偏置电流允许使用较大的电流感测电阻器，从而能够提供微安级的精确电流测量。零漂移架构的低失调电压扩展了电流测量的动态范围。此功能可支持较小的感应电阻器在具有较低功率损耗的同时，仍提供精确的电流测量。

INA186-Q1 由 1.7V 至 5.5V 单电源供电，在启用时消耗的最大电源电流为 90 μA。提供了五种固定增益选项：25V/V、50V/V、100V/V、200V/V 或 500V/V。该器件的额定工作温度范围为 -40°C 至 +125°C，并且采用 SC70、SOT-23 (5) 和 SOT-23 (8) 封装。SC70 和 SOT-23 (DDF) 封装支持双向电流测量，而 SOT-23 (DBV) 仅支持单向电流测量。

表 3-1. 器件信息

器件型号	封装 ⁽¹⁾	封装尺寸 (标称值)
INA186-Q1	SC70 (6)	2.00mm × 1.25mm
	SOT-23 (5)	2.90mm × 1.60mm
	SOT-23 (8)	2.90mm × 1.60mm

(1) 如需了解所有可用封装，请参阅产品说明书末尾的封装选项附录。



Table of Contents

1 特性	1	8 Application and Implementation	19
2 应用	1	8.1 Application Information.....	19
3 说明	1	8.2 Typical Applications.....	24
4 Revision History	2	9 Power Supply Recommendations	25
5 Pin Configuration and Functions	3	10 Layout	26
6 Specifications	4	10.1 Layout Guidelines.....	26
6.1 Absolute Maximum Ratings.....	4	10.2 Layout Examples.....	26
6.2 ESD Ratings.....	4	11 Device and Documentation Support	29
6.3 Recommended Operating Conditions.....	4	11.1 Documentation Support.....	29
6.4 Thermal Information.....	4	11.2 接收文档更新通知.....	29
6.5 Electrical Characteristics.....	6	11.3 支持资源.....	29
6.6 Typical Characteristics.....	7	11.4 Trademarks.....	29
7 Detailed Description	12	11.5 Electrostatic Discharge Caution.....	29
7.1 Overview.....	12	11.6 术语表.....	29
7.2 Functional Block Diagram.....	12	12 Mechanical, Packaging, and Orderable Information	29
7.3 Feature Description.....	13		
7.4 Device Functional Modes.....	15		

4 Revision History

Changes from Revision A (May 2020) to Revision B (March 2022)	Page
• 将数据表标题从“INA186-Q1 适用于成本敏感型系统的汽车类 40V 电流感测放大器”更改为“INA186-Q1 符合 AEC-Q100 标准且具有皮安级 IB 和使能引脚的 40V、双向、高精度电流感测放大器”.....	1
• 更新了整个文档中的表格、图和交叉参考的编号格式.....	1
• 向数据表添加了 DDF (SOT-23) 封装和相关内容.....	1
• Added RTI at the end of Refrence voltage rejection ratio.....	6

Changes from Revision * (May 2019) to Revision A (May 2020)	Page
• 添加了“提供功能安全”信息.....	1
• 向数据表添加了 DBV (SOT-23) 封装和相关内容.....	1

5 Pin Configuration and Functions



图 5-1. DCK Package 6-Pin SC70 Top View



图 5-2. DBV Package 5-Pin SOT-23 Top View

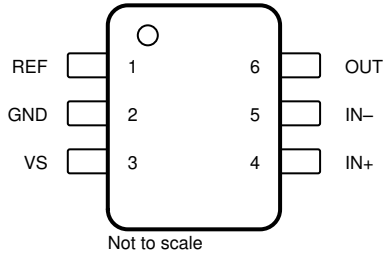

图 5-3. DDF Package 8-Pin SOT-23 Top View

表 5-1. Pin Functions

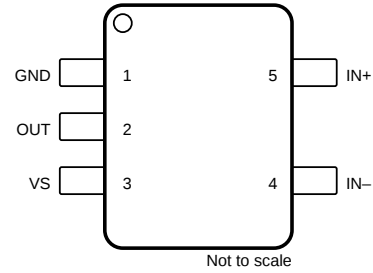
NAME	PIN			TYPE	DESCRIPTION
	DCK	DBV	DDF		
ENABLE	—	—	2	Digital input	Enable Pin. When this pin is driven to VS, the device is on and functions as a current sense amplifier. When this pin is driven to GND, the device is off, the supply current is reduced, and the output is placed in a high-impedance state. This pin must be driven externally, or connected to VS if not used. DDF package only.
GND	2	1	4	Analog	Ground
IN -	5	4	8	Analog input	Current-sense amplifier negative input. For high-side applications, connect to load side of sense resistor. For low-side applications, connect to ground side of sense resistor.
IN+	4	5	7	Analog input	Current-sense amplifier positive input. For high-side applications, connect to bus voltage side of sense resistor. For low-side applications, connect to load side of sense resistor.
NC	—	—	6	—	No internal connection. Can be left floating, grounded, or connected to supply.
OUT	6	2	5	Analog output	OUT pin. This pin provides an analog voltage output that is the gained up voltage difference from the IN+ to the IN - pins, and is offset by the voltage applied to the REF pin.
REF	1	—	3	Analog input	Reference input. Enables bidirectional current sensing with an externally applied voltage. DCK and DDF packages only. Devices without a REF pin have this node internally connected to GND.
VS	3	3	1	Analog	Power supply, 1.7 V to 5.5 V

6 Specifications

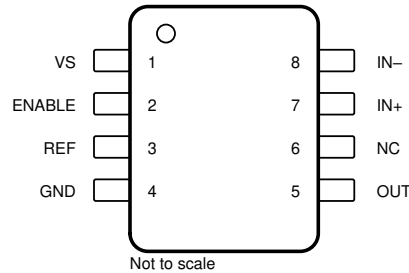
6.1 Absolute Maximum Ratings

over operating free-air temperature range (unless otherwise noted)⁽¹⁾

		MIN	MAX	UNIT	
V _S	Supply voltage		6	V	
V _{IN+} , V _{IN-}	Analog inputs	Differential (V _{IN+}) - (V _{IN-}) ⁽²⁾	- 42	42	V
		V _{IN+} , V _{IN-} , with respect to GND ⁽³⁾	GND - 0.3	42	
V _{ENABLE}	ENABLE	GND - 0.3	6	V	
	REF, OUT ⁽³⁾	GND - 0.3	(V _S) + 0.3	V	
	Input current into any pin ⁽³⁾		5	mA	
T _A	Operating temperature	- 55	150	°C	
T _J	Junction temperature		150	°C	
T _{stg}	Storage temperature	- 65	150	°C	

- (1) Stresses beyond those listed under *Absolute Maximum Ratings* may cause permanent damage to the device. These are stress ratings only, which do not imply functional operation of the device at these or any other conditions beyond those indicated under *Recommended Operating Conditions*. Exposure to absolute-maximum-rated conditions for extended periods may affect device reliability.
- (2) V_{IN+} and V_{IN-} are the voltages at the IN+ and IN- pins, respectively.
- (3) Input voltage at any pin may exceed the voltage shown if the current at that pin is limited to 5 mA.

6.2 ESD Ratings

			VALUE	UNIT
V _(ESD)	Electrostatic discharge	Human-body model (HBM), per AEC Q100-002 ⁽¹⁾ HBM ESD Classification Level 2	±3000	V
		Charged-device model (CDM), per AEC Q100-011 CDM ESD Classification Level C6	±1000	

- (1) AEC Q100-002 indicates that HBM stressing shall be in accordance with the ANSI/ESDA/JEDEC JS-001 specification.

6.3 Recommended Operating Conditions

over operating free-air temperature range (unless otherwise noted)

		MIN	NOM	MAX	UNIT
V _{CM}	Common-mode input range	GND - 0.2		40	V
V _{IN+} , V _{IN-}	Input pin voltage range	GND - 0.2		40	V
V _S	Operating supply voltage	1.7		5.5	V
V _{REF}	Reference pin voltage range	GND		V _S	V
T _A	Operating free-air temperature	- 40		125	°C

6.4 Thermal Information

THERMAL METRIC ⁽¹⁾		INA186-Q1			UNIT
		DBV (SOT23)	DCK (SC70)	DDF (SOT23)	
		5 PINS	6 PINS	8 PINS	
R _{qJA}	Junction-to-ambient thermal resistance	176.3	170.7	164.6	°C/W
R _{qJC(top)}	Junction-to-case (top) thermal resistance	105.6	132.7	86.6	°C/W
R _{qJB}	Junction-to-board thermal resistance	66.4	65.3	84.3	°C/W
Y _{JT}	Junction-to-top characterization parameter	43.9	45.7	7.1	°C/W
Y _{JB}	Junction-to-board characterization parameter	66.1	65.2	83.8	°C/W

THERMAL METRIC ⁽¹⁾		INA186-Q1			UNIT
		DBV (SOT23)	DCK (SC70)	DDF (SOT23)	
		5 PINS	6 PINS	8 PINS	
$R_{qJC(bot)}$	Junction-to-case (bottom) thermal resistance	N/A	N/A	N/A	°C/W

- (1) For more information about traditional and new thermal metrics, see the [Semiconductor and IC Package Thermal Metrics](#) application report.

6.5 Electrical Characteristics

at $T_A = 25^\circ\text{C}$, $V_{\text{SENSE}} = V_{\text{IN}+} - V_{\text{IN}-}$, $V_S = 1.8\text{ V to } 5.0\text{ V}$, $V_{\text{IN}+} = 12\text{ V}$, $V_{\text{REF}} = V_S / 2$, and $V_{\text{ENABLE}} = V_S$ (unless otherwise noted)

PARAMETER		CONDITIONS	MIN	TYP	MAX	UNIT
INPUT						
CMRR	Common-mode rejection ratio	$V_{\text{SENSE}} = 0\text{ mV}$, $V_{\text{IN}+} = -0.1\text{ V to } 40\text{ V}$, $T_A = -40^\circ\text{C to } +125^\circ\text{C}$	120	150		dB
V_{OS}	Offset voltage, RTI ⁽¹⁾	$V_S = 1.8\text{ V}$, $V_{\text{SENSE}} = 0\text{ mV}$		-3	± 50	μV
dV_{OS}/dT	Offset drift, RTI	$V_{\text{SENSE}} = 0\text{ mV}$, $T_A = -40^\circ\text{C to } +125^\circ\text{C}$		0.05	0.5	$\mu\text{V}/^\circ\text{C}$
PSRR	Power-supply rejection ratio, RTI	$V_{\text{SENSE}} = 0\text{ mV}$, $V_S = 1.7\text{ V to } 5.5\text{ V}$		-1	± 10	$\mu\text{V}/\text{V}$
I_{IB}	Input bias current	$V_{\text{SENSE}} = 0\text{ mV}$		0.5	3	nA
I_{IO}	Input offset current	$V_{\text{SENSE}} = 0\text{ mV}$		± 0.07		nA
OUTPUT						
G	Gain	A1 devices		25		V/V
		A2 devices		50		
		A3 devices		100		
		A4 devices		200		
		A5 devices		500		
E_G	Gain error	$V_{\text{OUT}} = 0.1\text{ V to } V_S - 0.1\text{ V}$		-0.04%	$\pm 1\%$	
	Gain error drift	$T_A = -40^\circ\text{C to } +125^\circ\text{C}$		2	10	ppm/ $^\circ\text{C}$
	Nonlinearity error	$V_{\text{OUT}} = 0.1\text{ V to } V_S - 0.1\text{ V}$		$\pm 0.01\%$		
RVRR	Reference voltage rejection ratio, RTI	$V_{\text{REF}} = 100\text{ mV to } V_S - 100\text{ mV}$, $T_A = -40^\circ\text{C to } +125^\circ\text{C}$		± 2	± 10	$\mu\text{V}/\text{V}$
	Maximum capacitive load	No sustained oscillation		1		nF
VOLTAGE OUTPUT						
V_{SP}	Swing to V_S power-supply rail	$V_S = 1.8\text{ V}$, $R_L = 10\text{ k}\Omega$ to GND, $T_A = -40^\circ\text{C to } +125^\circ\text{C}$		$(V_S) - 20$	$(V_S) - 40$	mV
V_{SN}	Swing to GND	$V_S = 1.8\text{ V}$, $R_L = 10\text{ k}\Omega$ to GND, $T_A = -40^\circ\text{C to } +125^\circ\text{C}$, $V_{\text{SENSE}} = -10\text{ mV}$, $V_{\text{REF}} = 0\text{ V}$		$(V_{\text{GND}}) + 0.05$	$(V_{\text{GND}}) + 1$	mV
V_{ZL}	Zero current output voltage	$V_S = 1.8\text{ V}$, $R_L = 10\text{ k}\Omega$ to GND, $T_A = -40^\circ\text{C to } +125^\circ\text{C}$, $V_{\text{SENSE}} = 0\text{ mV}$, $V_{\text{REF}} = 0\text{ V}$		$(V_{\text{GND}}) + 2$	$(V_{\text{GND}}) + 10$	mV
FREQUENCY RESPONSE						
BW	Bandwidth	A1 devices, $C_{\text{LOAD}} = 10\text{ pF}$		45		kHz
		A2 devices, $C_{\text{LOAD}} = 10\text{ pF}$		37		
		A3 devices, $C_{\text{LOAD}} = 10\text{ pF}$		35		
		A4 devices, $C_{\text{LOAD}} = 10\text{ pF}$		33		
		A5 devices, $C_{\text{LOAD}} = 10\text{ pF}$		27		
SR	Slew rate	$V_S = 5.0\text{ V}$, $V_{\text{OUT}} = 0.5\text{ V to } 4.5\text{ V}$		0.3		V/ μs
t_s	Settling time	From current step to within 1% of final value		30		μs
NOISE, RTI⁽¹⁾						
	Voltage noise density			75		nV/ $\sqrt{\text{Hz}}$
ENABLE						
I_{EN}	Leakage input current	$0\text{ V} \leq V_{\text{ENABLE}} \leq V_S$		1	100	nA
V_{IH}	High-level input voltage		$0.7 \times V_S$		6	V
V_{IL}	Low-level input voltage		0		$0.3 \times V_S$	V
V_{HYS}	Hysteresis			300		mV
I_{ODIS}	Output leakage disabled	$V_S = 5.0\text{ V}$, $V_{\text{OUT}} = 0\text{ V to } 5.0\text{ V}$, $V_{\text{ENABLE}} = 0\text{ V}$		1	5	μA
POWER SUPPLY						
I_{Q}	Quiescent current	$V_S = 1.8\text{ V}$, $V_{\text{SENSE}} = 0\text{ mV}$		48	65	μA
		$V_S = 1.8\text{ V}$, $V_{\text{SENSE}} = 0\text{ mV}$, $T_A = -40^\circ\text{C to } +125^\circ\text{C}$			90	μA

at $T_A = 25^\circ\text{C}$, $V_{\text{SENSE}} = V_{\text{IN}+} - V_{\text{IN}-}$, $V_S = 1.8\text{ V to } 5.0\text{ V}$, $V_{\text{IN}+} = 12\text{ V}$, $V_{\text{REF}} = V_S / 2$, and $V_{\text{ENABLE}} = V_S$ (unless otherwise noted)

PARAMETER	CONDITIONS	MIN	TYP	MAX	UNIT
I_{QDIS}	Quiescent current disabled $V_{\text{ENABLE}} = 0\text{ V}$, $V_{\text{SENSE}} = 0\text{ mV}$		10	100	nA

(1) RTI = referred-to-input.

6.6 Typical Characteristics

at $T_A = 25^\circ\text{C}$, $V_{\text{SENSE}} = V_{\text{IN}+} - V_{\text{IN}-}$, $V_S = 1.8\text{ V to } 5.0\text{ V}$, $V_{\text{IN}+} = 12\text{ V}$, $V_{\text{REF}} = V_S / 2$, $V_{\text{ENABLE}} = V_S$, and for all gain options (unless otherwise noted)



图 6-1. Gain vs. Frequency



图 6-2. Power-Supply Rejection Ratio vs. Frequency

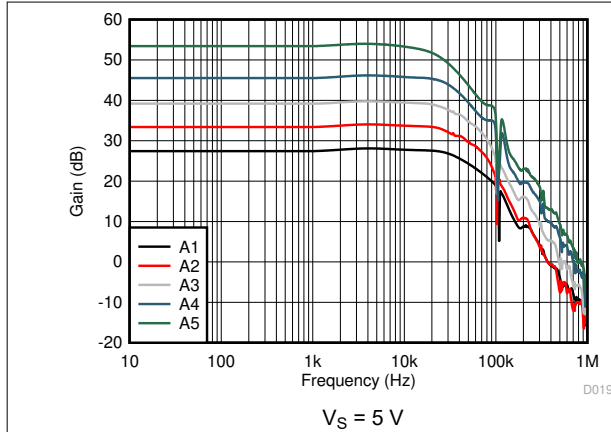

图 6-3. Common-Mode Rejection Ratio vs. Frequency

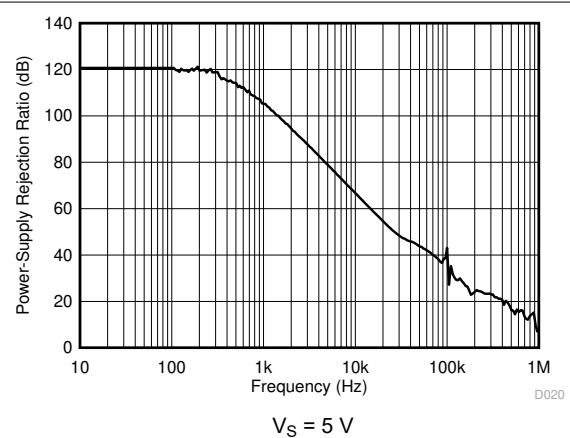

图 6-4. Output Voltage Swing vs. Output Current

6.6 Typical Characteristics (continued)

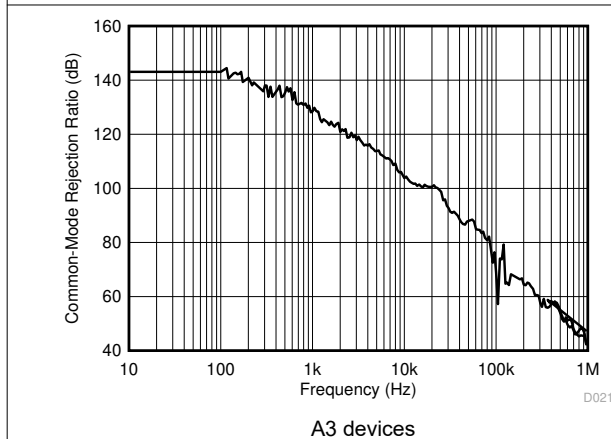
at $T_A = 25^\circ\text{C}$, $V_{\text{SENSE}} = V_{\text{IN}+} - V_{\text{IN}-}$, $V_S = 1.8\text{ V to } 5.0\text{ V}$, $V_{\text{IN}+} = 12\text{ V}$, $V_{\text{REF}} = V_S / 2$, $V_{\text{ENABLE}} = V_S$, and for all gain options (unless otherwise noted)

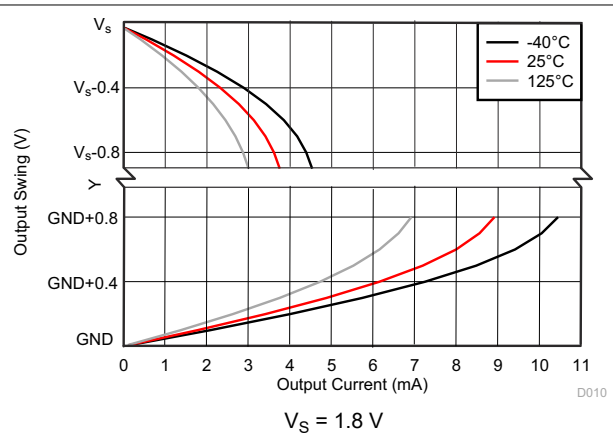

图 6-5. Output Voltage Swing vs. Output Current



图 6-6. Input Bias Current vs. Common-Mode Voltage

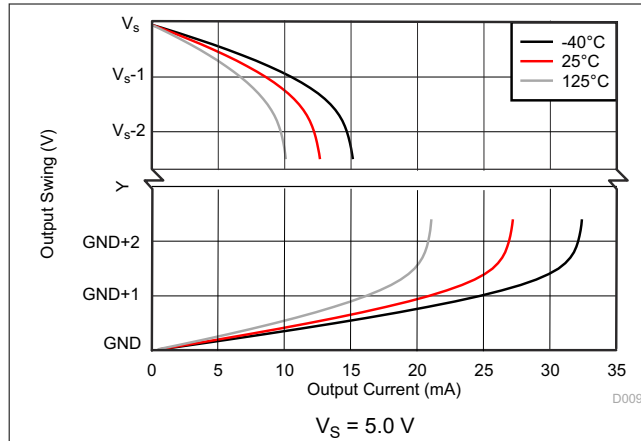

图 6-7. Input Bias Current vs. Common-Mode Voltage (Shutdown)

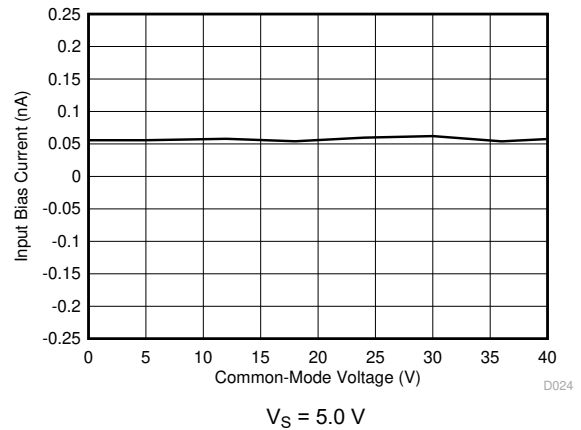

图 6-8. Quiescent Current vs. Temperature (Enabled)

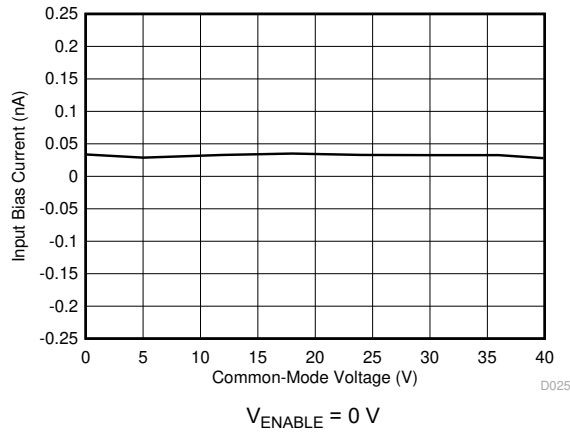

图 6-9. Quiescent Current vs. Temperature (Disabled)

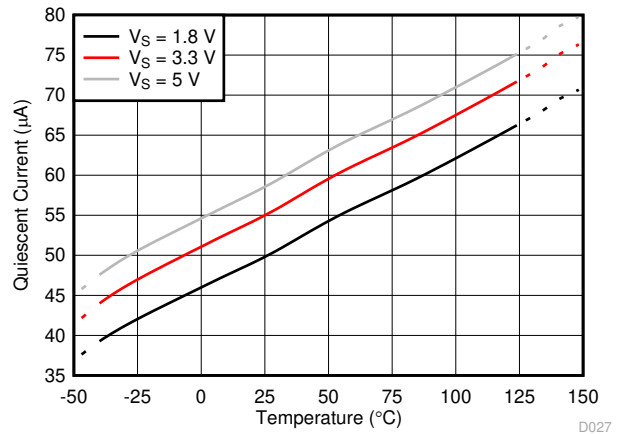

图 6-10. Quiescent Current vs. Common-Mode Voltage

6.6 Typical Characteristics (continued)

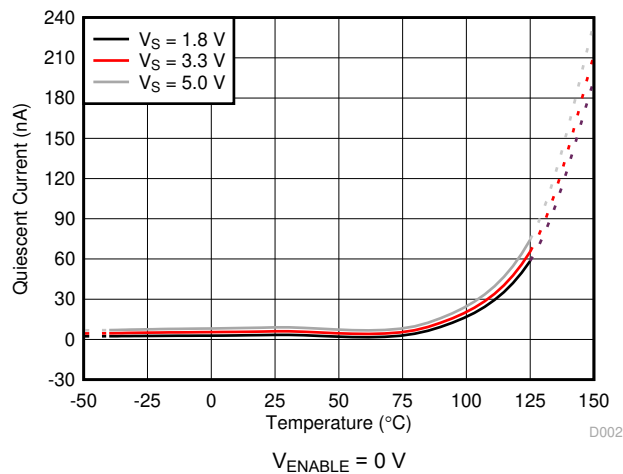
at $T_A = 25^\circ\text{C}$, $V_{\text{SENSE}} = V_{\text{IN}+} - V_{\text{IN}-}$, $V_S = 1.8\text{ V to } 5.0\text{ V}$, $V_{\text{IN}+} = 12\text{ V}$, $V_{\text{REF}} = V_S / 2$, $V_{\text{ENABLE}} = V_S$, and for all gain options (unless otherwise noted)

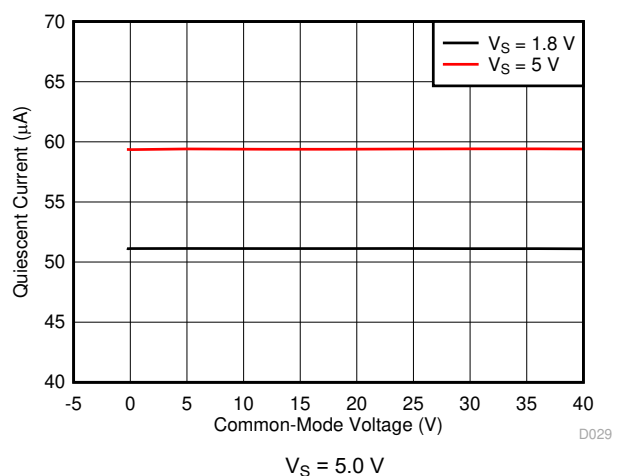

图 6-11. Input-Referred Voltage Noise vs. Frequency



图 6-12. 0.1-Hz to 10-Hz Voltage Noise (Referred-To-Input)

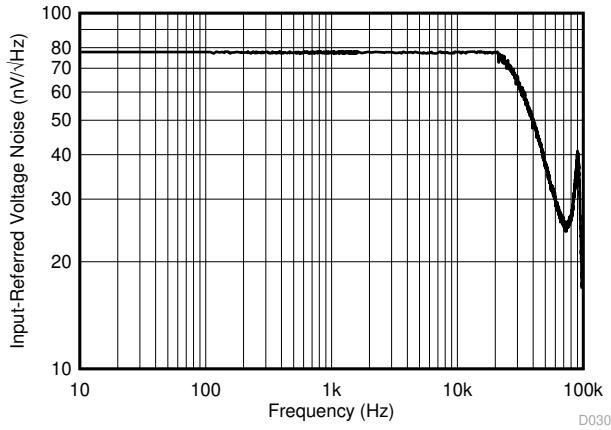

图 6-13. Step Response (10-mV_{PP} Input Step)

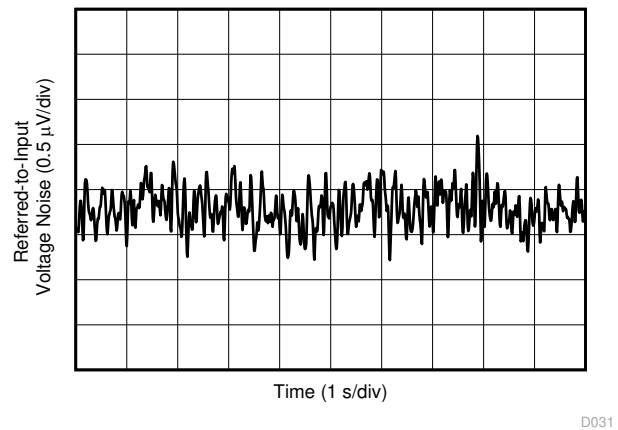

图 6-14. Common-Mode Voltage Transient Response

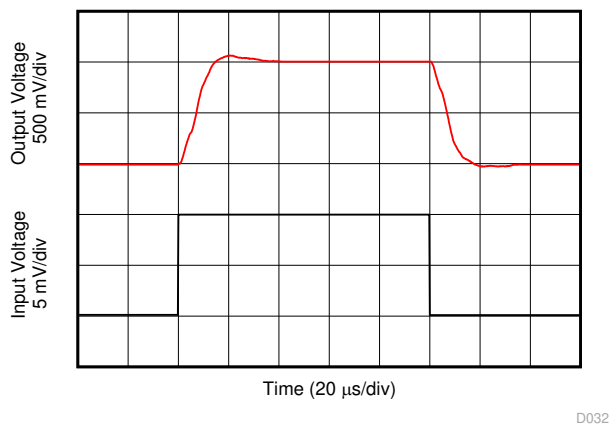

图 6-15. Inverting Differential Input Overload

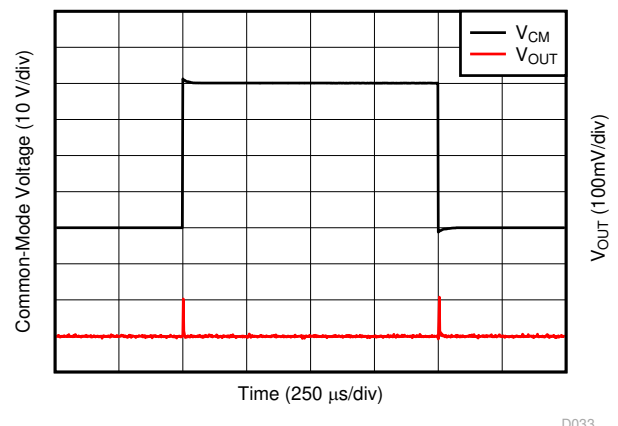

图 6-16. Noninverting Differential Input Overload

6.6 Typical Characteristics (continued)

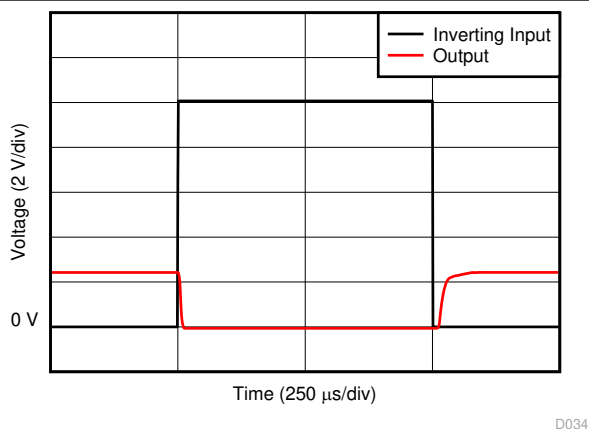
at $T_A = 25^\circ\text{C}$, $V_{\text{SENSE}} = V_{\text{IN}+} - V_{\text{IN}-}$, $V_S = 1.8\text{ V to } 5.0\text{ V}$, $V_{\text{IN}+} = 12\text{ V}$, $V_{\text{REF}} = V_S / 2$, $V_{\text{ENABLE}} = V_S$, and for all gain options (unless otherwise noted)

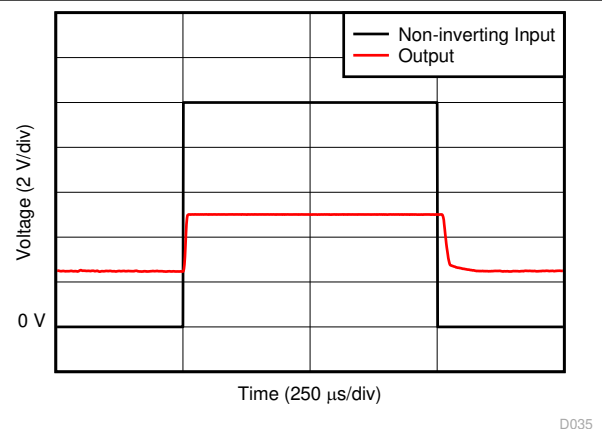
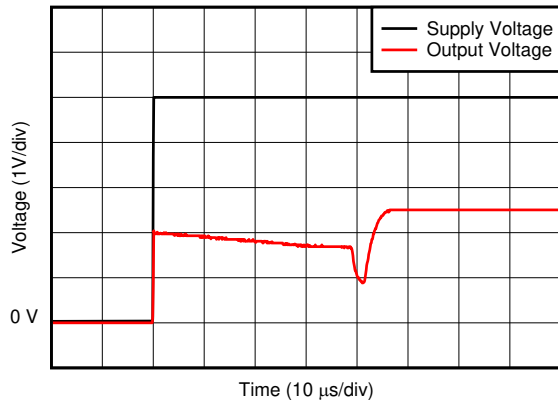

$V_S = 5.0\text{ V}$, A3 devices
图 6-17. Start-Up Response

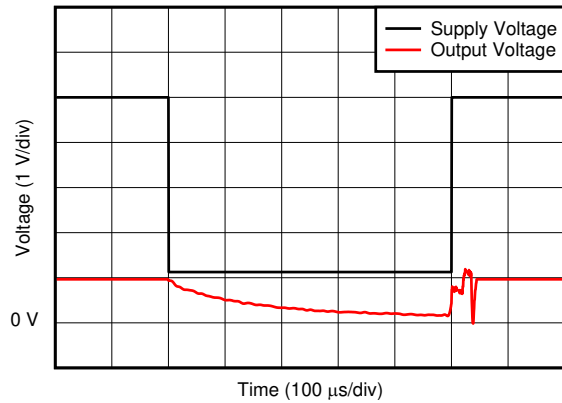

$V_S = 5.0\text{ V}$, A3 devices
图 6-18. Brownout Recovery

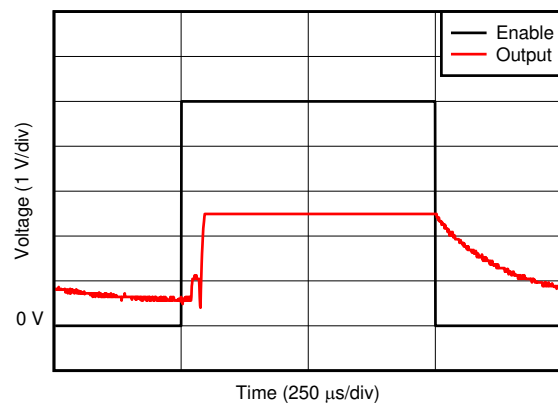

$V_S = 5.0\text{ V}$, A3 devices
图 6-19. Enable and Disable Response

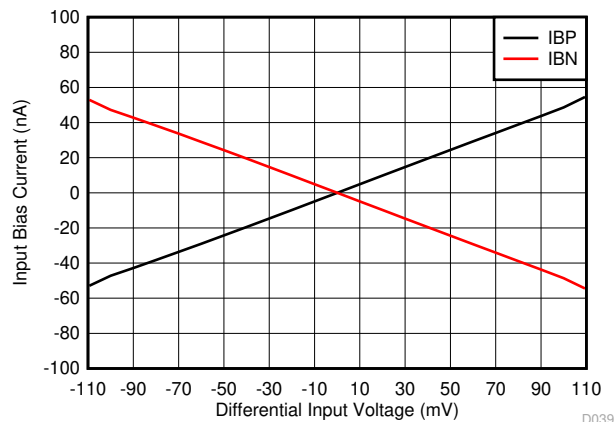

$V_S = 5.0\text{ V}$, $V_{\text{REF}} = 2.5\text{ V}$, A1 devices
图 6-20. IB+ and IB- vs. Differential Input Voltage

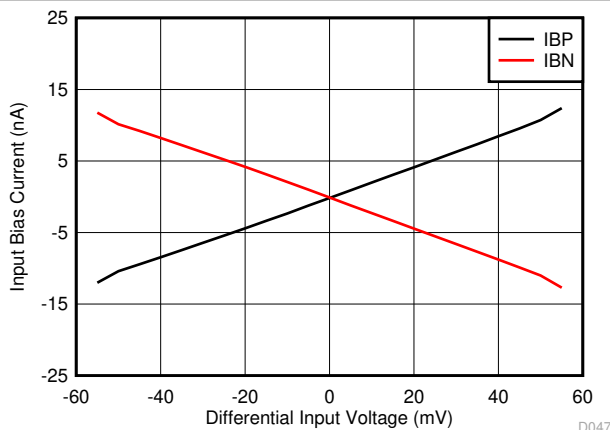

$V_S = 5.0\text{ V}$, $V_{\text{REF}} = 2.5\text{ V}$, A2, A3, A4, A5 devices
图 6-21. IB+ and IB- vs. Differential Input Voltage

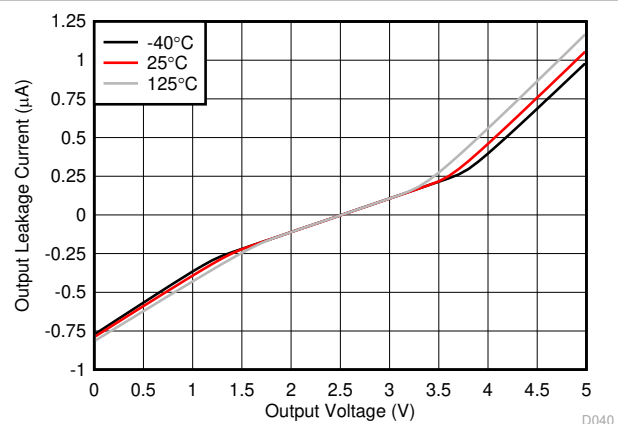

$V_S = 5.0\text{ V}$, $V_{\text{ENABLE}} = 0\text{ V}$, $V_{\text{REF}} = 2.5\text{ V}$
图 6-22. Output Leakage vs. Output Voltage (A1, A2, and A3 Devices)

6.6 Typical Characteristics (continued)

at $T_A = 25^\circ\text{C}$, $V_{\text{SENSE}} = V_{\text{IN}+} - V_{\text{IN}-}$, $V_S = 1.8\text{ V to } 5.0\text{ V}$, $V_{\text{IN}+} = 12\text{ V}$, $V_{\text{REF}} = V_S / 2$, $V_{\text{ENABLE}} = V_S$, and for all gain options (unless otherwise noted)

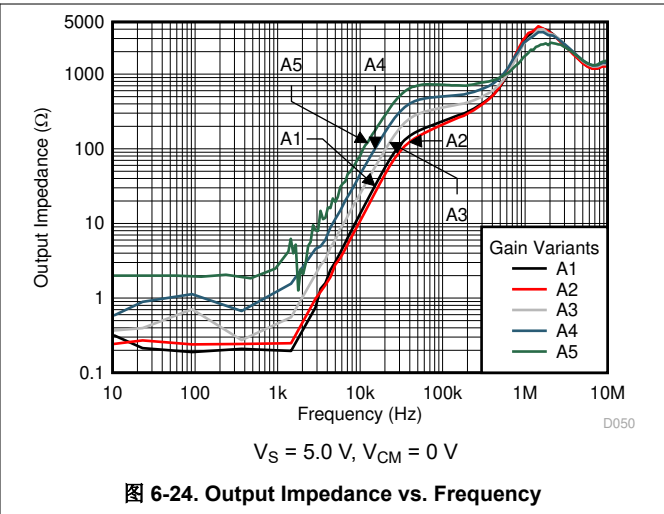
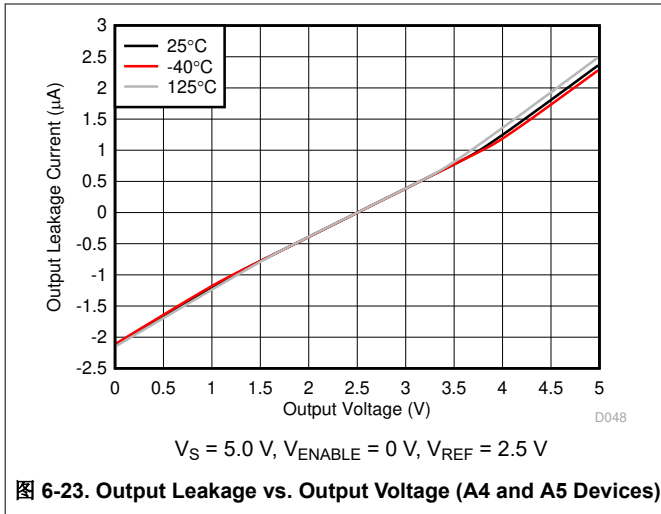

7 Detailed Description

7.1 Overview

The INA186-Q1 is a low bias current, low offset, 40-V common-mode, current-sensing amplifier. The DDF SOT-23 package also comes with an enable pin. The INA186-Q1 is a specially designed, current-sensing amplifier that accurately measures voltages developed across current-sensing resistors on common-mode voltages that far exceed the supply voltage. Current is measured on input voltage rails as high as 40 V at V_{IN+} and V_{IN-} , with a supply voltage, V_S , as low as 1.7 V. When disabled, the output goes to a high-impedance state, and the supply current draw is reduced to less than 0.1 μA . The INA186-Q1 is intended for use in both low-side and high-side current-sensing configurations where high accuracy and low current consumption are required.

7.2 Functional Block Diagram

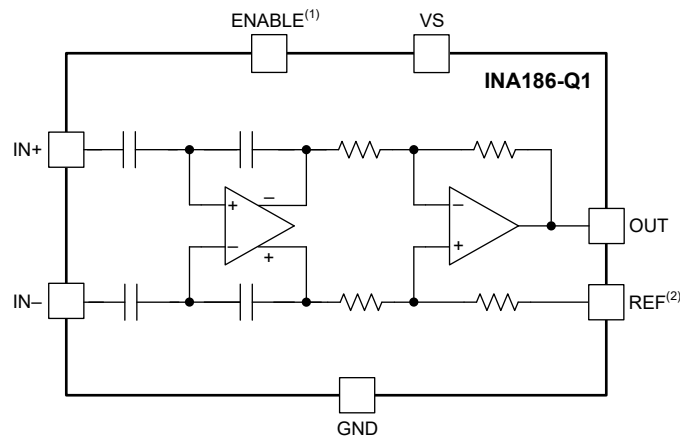

1. The ENABLE pin is available only in the DDF package.
2. The REF node for the DBV package is internally connected to GND.

7.3 Feature Description

7.3.1 Precision Current Measurement

The INA186-Q1 allows for accurate current measurements over a wide dynamic range. The high accuracy of the device is attributable to the low gain error and offset specifications. The offset voltage of the INA186-Q1 is less than $\pm 50 \mu\text{V}$. In this case, the low offset improves the accuracy at light loads when $V_{\text{IN}+}$ approaches $V_{\text{IN}-}$. Another advantage of low offset is the ability to use a lower-value shunt resistor that reduces the power loss in the current-sense circuit, and improves the power efficiency of the end application.

The maximum gain error of the INA186-Q1 is specified at $\pm 1\%$. As the sensed voltage becomes much larger than the offset voltage, the gain error becomes the dominant source of error in the current-sense measurement. When the device monitors currents near the full-scale output range, the total measurement error approaches the value of the gain error.

7.3.2 Low Input Bias Current

The INA186-Q1 is different from many current-sense amplifiers because this device offers very low input bias current. The low input bias current of the INA186-Q1 has three primary benefits.

The first benefit is the reduction of the current consumed by the device. Classical current-sense amplifier topologies typically consume tens of microamps of current at the inputs. For these amplifiers, the input current is the result of the resistor network that sets the gain and additional current to bias the input amplifier. To reduce the bias current to near zero, the INA186-Q1 uses a capacitively coupled amplifier on the input stage, followed by a difference amplifier on the output stage.

The second benefit of low bias current is the ability to use input filters to reject high-frequency noise before the signal is amplified. In a traditional current-sense amplifier, the addition of input filters comes at the cost of reduced accuracy. However, as a result of the low bias currents, input filters have little effect on the measurement accuracy of the INA186-Q1.

The third benefit of low bias current is the ability to use a larger current-sense resistor. This ability allows the device to accurately monitor currents as low as $1 \mu\text{A}$.

7.3.3 Low Quiescent Current With Output Enable

The device features low quiescent current (I_Q), while still providing sufficient small-signal bandwidth to be usable in most applications. The quiescent current of the INA186-Q1 is only $48 \mu\text{A}$ (typical), while providing a small-signal bandwidth of 35 kHz in a gain of 100. The low I_Q and good bandwidth allow the device to be used in many portable electronic systems without excessive drain on the battery. Because many applications only need to periodically monitor current, the INA186-Q1 features an enable pin that turns off the device until needed. When in the disabled state, the INA186-Q1 typically draws 10 nA of total supply current.

7.3.4 Bidirectional Current Monitoring

The INA186-Q1 devices that feature a REF pin can sense current flow through a sense resistor in both directions. The bidirectional current-sensing capability is achieved by applying a voltage at the REF pin to offset the output voltage. A positive differential voltage sensed at the inputs results in an output voltage that is greater than the applied reference voltage. Likewise, a negative differential voltage at the inputs results in output voltage that is less than the applied reference voltage. Use [方程式 1](#) to calculate the output voltage of the current-sense amplifier.

$$V_{\text{OUT}} = (I_{\text{LOAD}} \times R_{\text{SENSE}} \times \text{GAIN}) + V_{\text{REF}} \quad (1)$$

where

- I_{LOAD} is the load current to be monitored.
- R_{SENSE} is the current-sense resistor.
- GAIN is the gain option of the selected device.
- V_{REF} is the voltage applied to the REF pin.

7.3.5 High-Side and Low-Side Current Sensing

The INA186-Q1 supports input common-mode voltages from -0.2 V to $+40\text{ V}$. Because of the internal topology, the common-mode range is not restricted by the power-supply voltage (V_S). The INA186-Q1 has the ability to operate with common-mode voltage greater or less than V_S . 图 7-1 shows an example on how the INA186-Q1 can be used in high-side and low-side current-sensing applications.



图 7-1. High-Side and Low-Side Sensing Connections

7.3.6 High Common-Mode Rejection

The INA186-Q1 uses a capacitively coupled amplifier on the front end. Therefore, dc common-mode voltages are blocked from downstream circuits, resulting in very high common-mode rejection. Typically, the common-mode rejection of the INA186-Q1 is approximately 150 dB. The ability to reject changes in the dc common-mode voltage allows the INA186-Q1 to monitor both high-voltage and low-voltage rail currents with very little change in the offset voltage.

7.3.7 Rail-to-Rail Output Swing

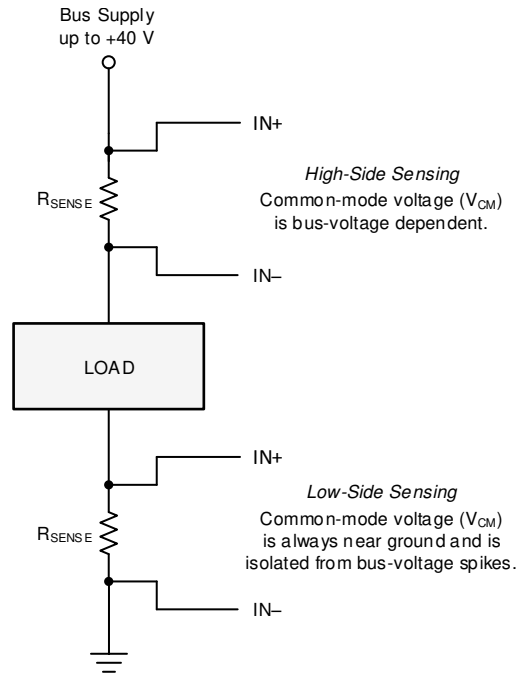
The INA186-Q1 allows linear current-sensing operation with the output close to the supply rail and ground. The maximum specified output swing to the positive rail is $V_S - 40\text{ mV}$, and the maximum specified output swing to GND is only $\text{GND} + 1\text{ mV}$. The close-to-rail output swing is useful to maximize the usable output range, particularly when operating the device from a 1.8-V supply.

7.4 Device Functional Modes

7.4.1 Normal Operation

The INA186-Q1 is in normal operation when the following conditions are met:

- The power-supply voltage (V_S) is between 1.7 V and 5.5 V.
- The common-mode voltage (V_{CM}) is within the specified range of -0.2 V to $+40$ V.
- The maximum differential input signal times the gain plus V_{REF} is less than the positive swing voltage V_{SP} .
- The ENABLE pin is driven or connected to V_S .
- The minimum differential input signal times the gain plus V_{REF} is greater than the zero load swing to GND, V_{ZL} (see [Rail-to-Rail Output Swing](#)).

For devices that do not feature a REF pin that value for V_{REF} will be zero. During normal operation, this device produces an output voltage that is the *amplified* representation of the difference voltage from $IN+$ to $IN-$ plus the voltage applied to the REF pin.

7.4.2 Unidirectional Mode

This device can be configured to monitor current flowing in one direction (unidirectional) or in both directions (bidirectional) depending on how the REF pin is connected. [图 7-2](#) shows the device operating in unidirectional mode where the output is near ground when no current is flowing. When the current flows from the bus supply to the load, the input voltage from $IN+$ to $IN-$ increases and causes the output voltage at the OUT pin to increase.



图 7-2. Typical Unidirectional Application

The linear range of the output stage is limited by how close the output voltage can approach ground under zero input conditions. The zero current output voltage of the INA186-Q1 is very small and for most unidirectional applications the REF pin is simply grounded. However, if the measured current multiplied by the current sense resistor and device gain is less than the zero current output voltage, then bias the REF pin to a convenient value above the zero current output voltage to get the output into the linear range of the device. To limit common-mode rejection errors, buffer the reference voltage connected to the REF pin.

A less-frequently used output biasing method is to connect the REF pin to the power-supply voltage, V_S . This method results in the output voltage saturating at 40 mV less than the supply voltage when no differential input voltage is present. This method is similar to the output saturated low condition with no differential input voltage when the REF pin is connected to ground. The output voltage in this configuration only responds to currents that develop negative differential input voltage relative to the device $IN-$ pin. Under these conditions, when the

negative differential input signal increases, the output voltage moves downward from the saturated supply voltage. The voltage applied to the REF pin must not exceed V_S .

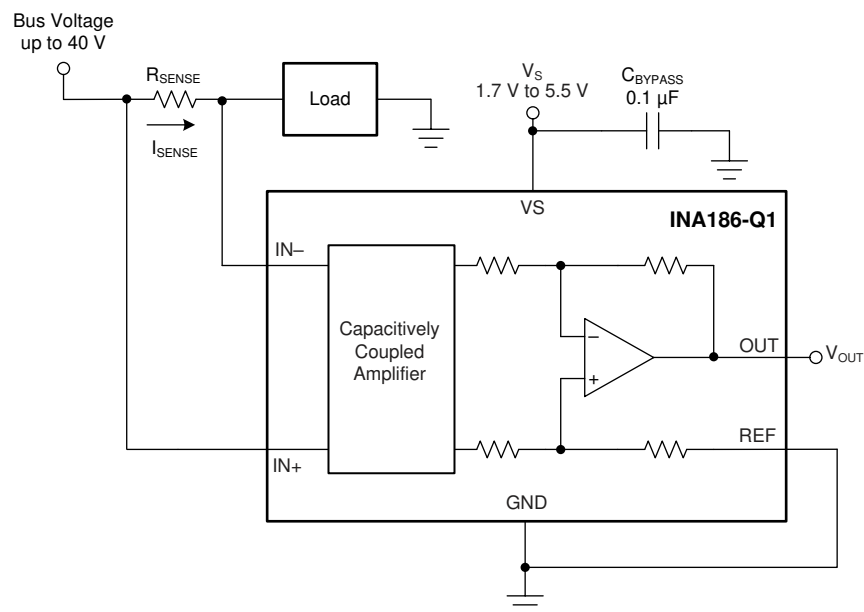
Another use for the REF pin in unidirectional operation is to level shift the output voltage. 图 7-3 shows an application where the device ground is set to a negative voltage so currents biased to negative supplies, as seen in optical networking cards, can be measured. The GND of the INA186-Q1 can be set to negative voltages, as long as the inputs do not violate the common-mode range specification and the voltage difference between V_S and GND does not exceed 5.5 V. In this example, the output of the INA186-Q1 is fed into a positive-biased analog-to-digital converter (ADC). By grounding the REF pin, the voltages at the output will be positive and not damage the ADC. To make sure the output voltage never goes negative, the supply sequencing must be the positive supply first, followed by the negative supply.



图 7-3. Using the REF Pin to Level-Shift Output Voltage

7.4.3 Bidirectional Mode

The INA186-Q1 devices that feature a REF pin are bidirectional current-sense amplifiers capable of measuring currents through a resistive shunt in two directions. This bidirectional monitoring is common in applications that include charging and discharging operations where the current flowing through the resistor can change directions.

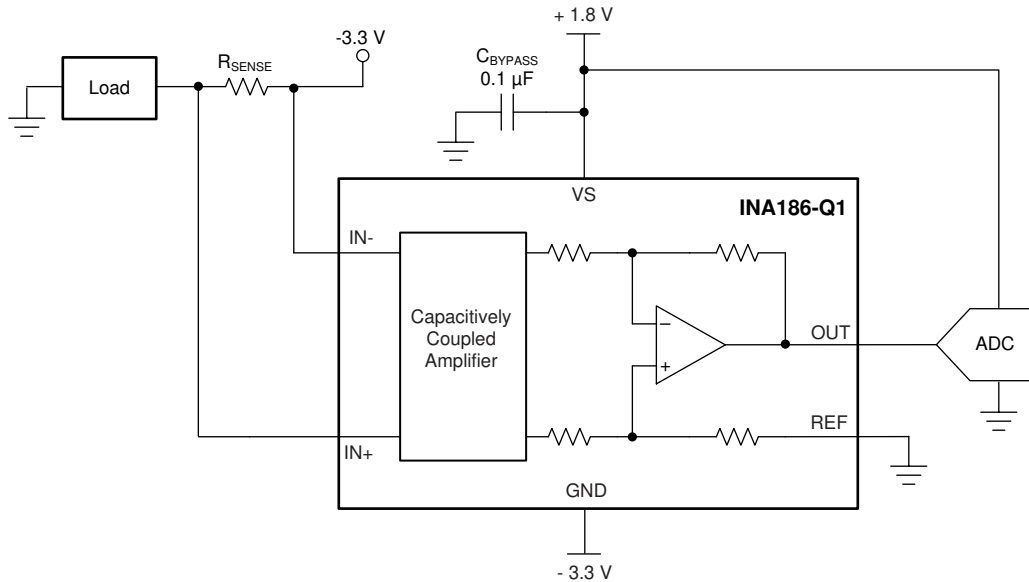

图 7-4. Bidirectional Application

By applying a voltage to the REF pin, [图 7-4](#) shows how you can measure this current flowing in both directions. The voltage applied to REF (V_{REF}) sets the output state that corresponds to the zero-input level state. The output then responds by increasing above V_{REF} for positive differential signals (relative to the IN - pin) and responds by decreasing below V_{REF} for negative differential signals. This reference voltage applied to the REF pin can be set anywhere between 0 V to V_S . For bidirectional applications, V_{REF} is typically set at $V_S/2$ for equal signal range in both current directions. In some cases, V_{REF} is set at a voltage other than $V_S/2$; for example, when the bidirectional current and corresponding output signal do not need to be symmetrical.

7.4.4 Input Differential Overload

If the differential input voltage ($V_{IN+} - V_{IN-}$) times gain exceeds the voltage swing specification, the INA186-Q1 drives its output as close as possible to the positive supply or ground, and does not provide accurate measurement of the differential input voltage. If this input overload occurs during normal circuit operation, then reduce the value of the shunt resistor or use a lower-gain version with the chosen sense resistor to avoid this mode of operation. If a differential overload occurs in a time-limited fault event, then the output of the INA186-Q1 returns to the expected value approximately 80 μ s after the fault condition is removed.

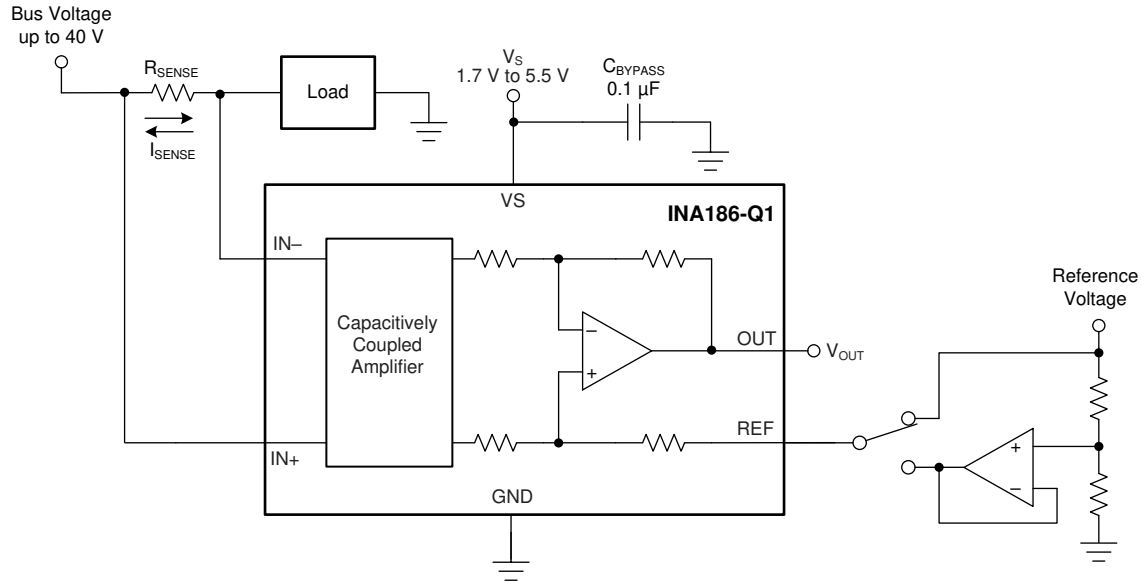
7.4.5 Shutdown

The INA186-Q1 features an active-high ENABLE pin that shuts down the device when pulled to ground. When the device is shut down, the quiescent current is reduced to 10 nA (typical), and the output goes to a high-impedance state. In a battery-powered application, the low quiescent current extends the battery lifetime when the current measurement is not needed. When the ENABLE pin is driven to the supply voltage, the device turns back on. The typical output settling time when enabled is 130 μ s.

The output of the INA186-Q1 goes to a high-impedance state when disabled. 图 7-5 shows how to connect multiple outputs of the INA186-Q1 together to a single ADC or measurement device.

When connected in this way, enable only one INA186-Q1 at a time, and make sure all devices have the same supply voltage.



图 7-5. Multiplexing Multiple Devices With the ENABLE Pin

8 Application and Implementation

备注

以下应用部分中的信息不属于 TI 器件规格的范围，TI 不担保其准确性和完整性。TI 的客户应负责确定器件是否适用于其应用。客户应验证并测试其设计，以确保系统功能。

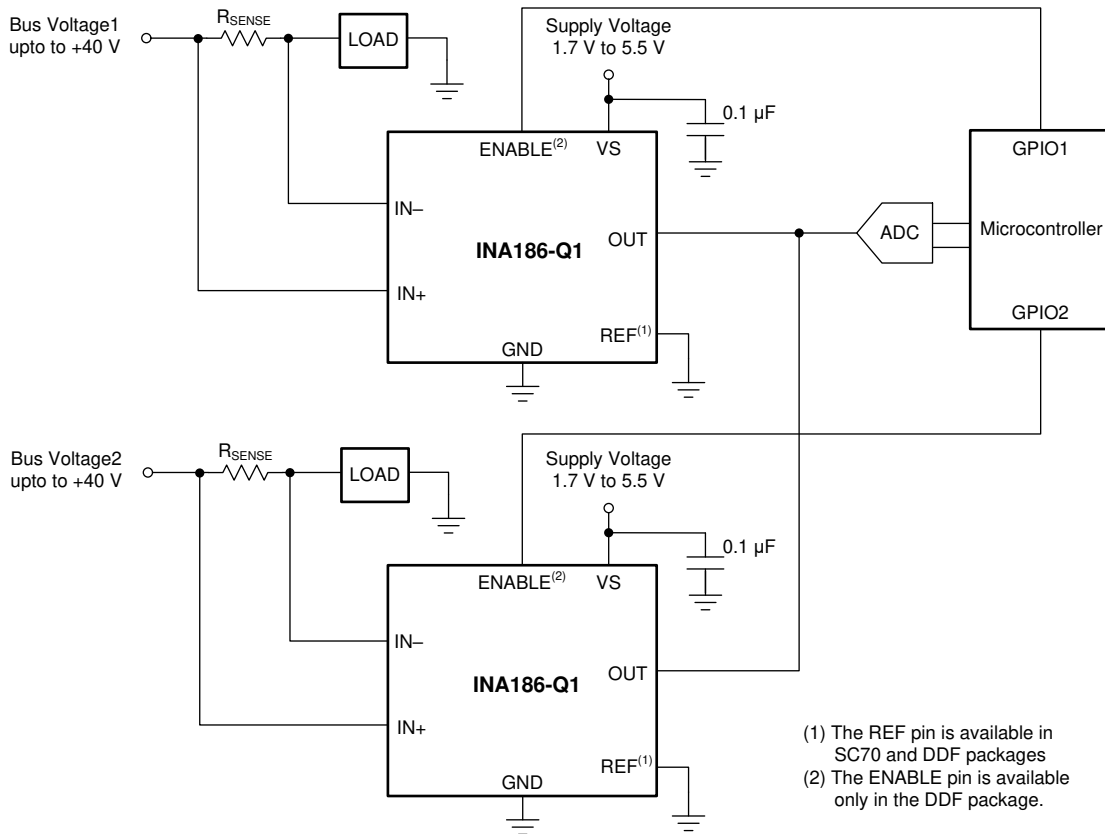
8.1 Application Information

The INA186-Q1 amplifies the voltage developed across a current-sensing resistor as current flows through the resistor to the load or ground. The high common-mode rejection of the INA186-Q1 makes it usable over a wide range of voltage rails while still maintaining an accurate current measurement.

8.1.1 Basic Connections

图 8-1 shows the basic connections of the INA186-Q1. Place the device as close as possible to the current sense resistor and connect the input pins (IN+ and IN-) to the current sense resistor through kelvin connections.

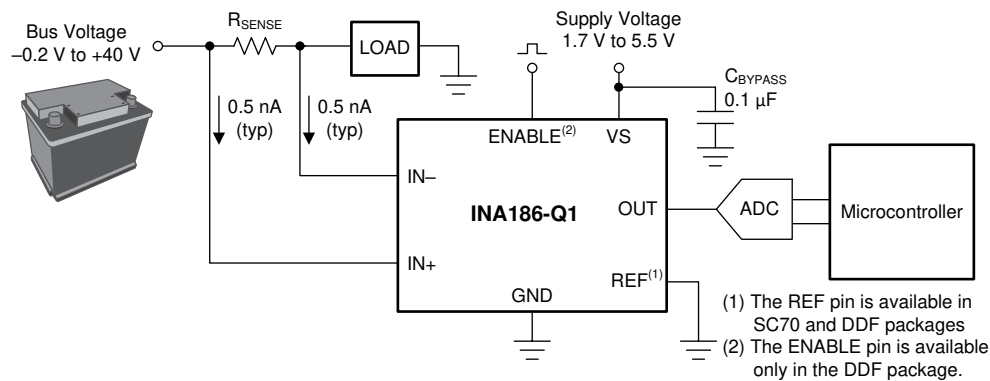

- A. To help eliminate ground offset errors between the device and the analog-to-digital converter (ADC), connect the REF pin to the ADC reference input. When driving SAR ADCs, filter or buffer the output of the INA186-Q1 before connecting directly to the ADC.

图 8-1. Basic Connections

8.1.2 R_{SENSE} and Device Gain Selection

The accuracy of any current-sense amplifier is maximized by choosing the current-sense resistor to be as large as possible. A large sense resistor maximizes the differential input signal for a given amount of current flow and reduces the error contribution of the offset voltage. However, there are practical limits as to how large the current-sense resistor can be in a given application because of the resistor size and maximum allowable power dissipation. [方程式 2](#) gives the maximum value for the current-sense resistor for a given power dissipation budget:

$$R_{\text{SENSE}} < \frac{PD_{\text{MAX}}}{I_{\text{MAX}}^2} \quad (2)$$

where:

- PD_{MAX} is the maximum allowable power dissipation in R_{SENSE} .
- I_{MAX} is the maximum current that will flow through R_{SENSE} .

An additional limitation on the size of the current-sense resistor and device gain is due to the power-supply voltage, V_S , and device swing-to-rail limitations. In order to make sure that the current-sense signal is properly passed to the output, both positive and negative output swing limitations must be examined. [方程式 3](#) provides the maximum values of R_{SENSE} and GAIN to keep the device from exceeding the positive swing limitation.

$$I_{\text{MAX}} \times R_{\text{SENSE}} \times \text{GAIN} < V_{\text{SP}} - V_{\text{REF}} \quad (3)$$

where:

- I_{MAX} is the maximum current that will flow through R_{SENSE} .
- GAIN is the gain of the current-sense amplifier.
- V_{SP} is the positive output swing as specified in the data sheet.
- V_{REF} is the externally applied voltage on the REF pin. This voltage is zero for devices without a REF pin.

To avoid positive output swing limitations when selecting the value of R_{SENSE} , there is always a trade-off between the value of the sense resistor and the gain of the device under consideration. If the sense resistor selected for the maximum power dissipation is too large, then it is possible to select a lower-gain device in order to avoid positive swing limitations.

The negative swing limitation places a limit on how small the sense resistor value can be for a given application. [方程式 4](#) provides the limit on the minimum value of the sense resistor.

$$I_{\text{MIN}} \times R_{\text{SENSE}} \times \text{GAIN} > V_{\text{SN}} - V_{\text{REF}} \quad (4)$$

where:

- I_{MIN} is the minimum current that will flow through R_{SENSE} .
- GAIN is the gain of the current-sense amplifier.
- V_{SN} is the negative output swing of the device (see [Rail-to-Rail Output Swing](#)).
- V_{REF} is the externally applied voltage on the REF pin. This voltage is zero for devices without a REF pin.

In addition to adjusting R_{SENSE} and the device gain, the voltage applied to the REF pin can be slightly increased above GND to avoid negative swing limitations.

8.1.3 Signal Conditioning

When performing accurate current measurements in noisy environments, the current-sensing signal is often filtered. The INA186-Q1 features low input bias currents. Therefore, adding a differential mode filter to the input without sacrificing the current-sense accuracy is possible. Filtering at the input is advantageous because this action attenuates differential noise before the signal is amplified. 图 8-2 provides an example of how to use a filter on the input pins of the device.



图 8-2. Filter at the Input Pins

图 8-3 shows the value of R_{DIFF} is a function of the device temperature.

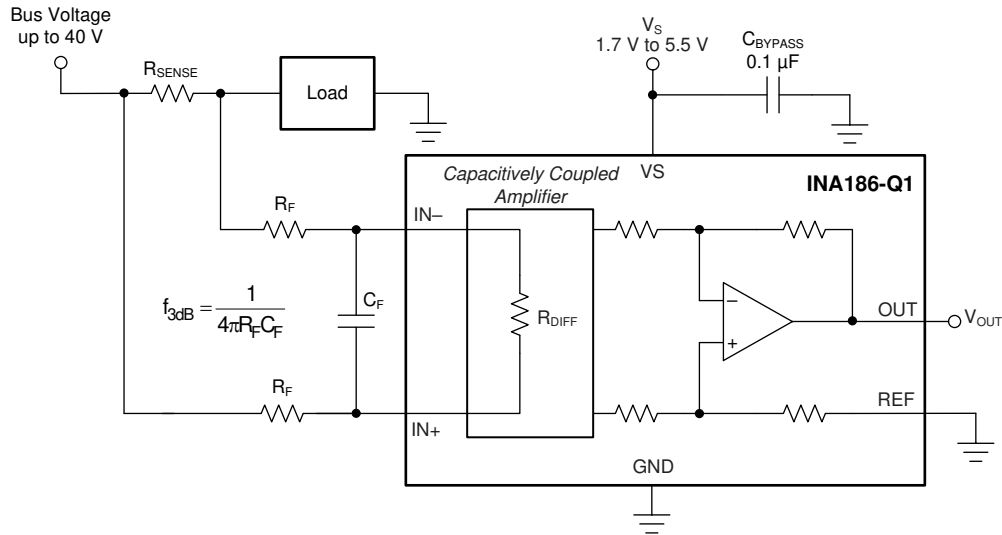

图 8-3. Differential Input Impedance vs. Temperature

As the voltage drop across the sense resistor (V_{SENSE}) increases, the amount of voltage dropped across the input filter resistors (R_F) also increases. The increased voltage drop results in additional gain error. The error caused by these resistors is calculated by the resistor divider equation shown in [方程式 5](#).

$$\text{Error(\%)} = \left(1 - \frac{R_{\text{DIFF}}}{R_{\text{SENSE}} + R_{\text{DIFF}} + (2 \times R_F)} \right) \times 100 \quad (5)$$

where:

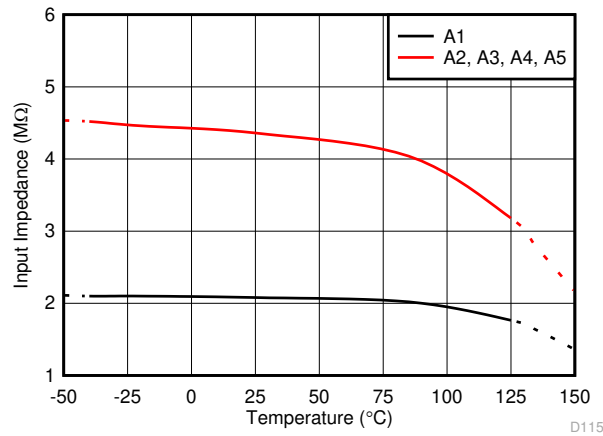
- R_{DIFF} is the differential input impedance.
- R_F is the added value of the series filter resistance.

The input stage of the INA186-Q1 uses a capacitive feedback amplifier topology in order to achieve high dc precision. As a result, periodic high-frequency shunt voltage (or current) transients of significant amplitude (10 mV or greater) and duration (hundreds of nanoseconds or greater) may be amplified by the INA186-Q1, even though the transients are greater than the device bandwidth. Use a differential input filter in these applications to minimize disturbances at the INA186-Q1 output.

The high input impedance and low bias current of the INA186-Q1 provide flexibility in the input filter design without impacting the accuracy of current measurement. For example, set $R_F = 100 \Omega$ and $C_F = 22 \text{ nF}$ to achieve a low-pass filter corner frequency of 36.2 kHz. These filter values significantly attenuate most unwanted high-frequency signals at the input without severely impacting the current sensing bandwidth or precision. If a lower corner frequency is desired, increase the value of C_F .

Filtering the input filters out differential noise across the sense resistor. If high-frequency, common-mode noise is a concern, add an RC filter from the OUT pin to ground. The RC filter helps filter out both differential and common mode noise, as well as internally generated noise from the device. The value for the resistance of the RC filter is limited by the impedance of the load. Any current drawn by the load manifests as an external voltage drop from the INA186-Q1 OUT pin to the load input. To select the optimal values for the output filter, use [图 6-24](#) and see the [Closed-Loop Analysis of Load-Induced Amplifier Stability Issues Using ZOUT application report](#)

8.1.4 Common-Mode Voltage Transients

With a small amount of additional circuitry, the INA186-Q1 can be used in circuits subject to transients that exceed the absolute maximum voltage ratings. The most simple way to protect the inputs from negative transients is to add resistors in series with the IN⁻ and IN⁺ pins. Use resistors that are 1 k Ω or less, and limit the current in the ESD structures to less than 5 mA. For example, using 1-k Ω resistors in series with the INA186-Q1 allows voltages as low as -5 V, while limiting the ESD current to less than 5 mA. Use the circuits shown in [Figure 8-4](#) and [Figure 8-5](#) if protection from high-voltage positive or negative, common-voltage transients is needed. When implementing these circuits, use only Zener diodes or Zener-type transient absorbers (sometimes referred to as *transzorb*s); any other type of transient absorber has an unacceptable time delay. Start by adding a pair of resistors as a working impedance for the Zener diode (see [Figure 8-4](#)). Keep these resistors as small as possible; most often, use around 100 Ω . See [Signal Conditioning](#) for information on how larger values can be used with an effect on gain. This circuit limits only short-term transients; therefore, many applications are satisfied with a 100- Ω resistor along with conventional Zener diodes of the lowest acceptable power rating. This combination uses the least amount of board space. These diodes can be found in packages as small as SOT-523 or SOD-523.

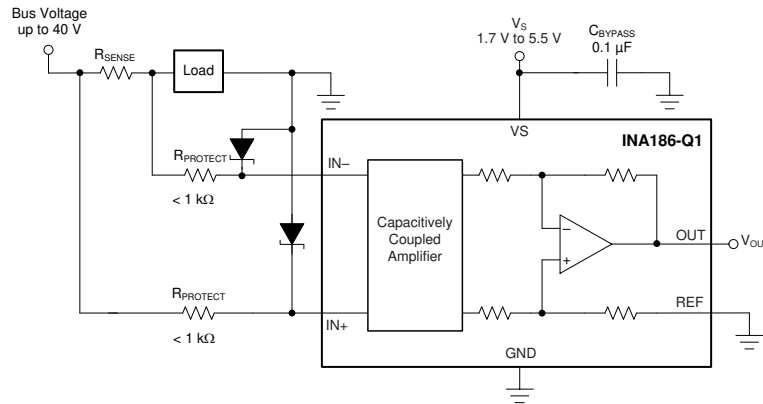

Figure 8-4. Transient Protection Using Dual Zener Diodes

In the event that low-power Zener diodes do not have sufficient transient absorption capability, a higher-power transzorb must be used. The most package-efficient solution involves using a single transzorb and back-to-back diodes between the device inputs, as shown in [Figure 8-5](#). The most space-efficient solutions are dual, series-connected diodes in a single SOT-523 or SOD-523 package. In either of the examples shown in [Figure 8-4](#) and [Figure 8-5](#), the total board area required by the INA186-Q1 with all protective components is less than that of an SO-8 package, and only slightly greater than that of an VSSOP-8 package.

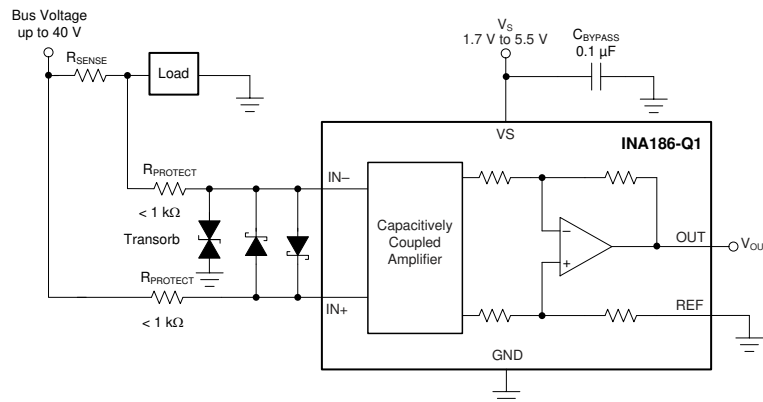

Figure 8-5. Transient Protection Using a Single Transzorb and Input Clamps

For more information, see the [Current Shunt Monitor With Transient Robustness reference design](#).

8.2 Typical Applications

The low input bias current of the INA186-Q1 allows accurate monitoring of small-value currents. To accurately monitor currents in the microamp range, increase the value of the sense resistor to increase the sense voltage so that the error introduced by the offset voltage is small. 图 8-6 shows the circuit configuration for monitoring low-value currents. As a result of the differential input impedance of the INA186-Q1, limit the value of R_{SENSE} to 1 k Ω or less for best accuracy.



图 8-6. Microamp Current Measurement

8.2.1 Design Requirements

表 8-1 lists the design requirements for the circuit shown in 图 8-6.

表 8-1. Design Parameters

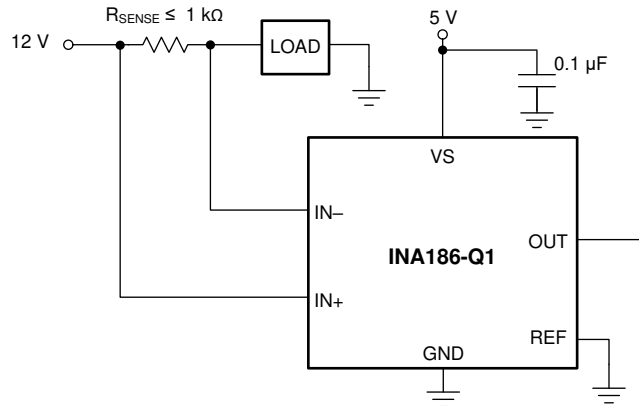
DESIGN PARAMETER	EXAMPLE VALUE
Power-supply voltage (V_S)	5 V
Bus supply rail (V_{CM})	12 V
Minimum sense current (I_{MIN})	1 μ A
Maximum sense current (I_{MAX})	150 μ A
Device gain (GAIN)	25 V/V
Reference voltage (V_{REF})	0 V

8.2.2 Detailed Design Procedure

The maximum value of the current-sense resistor is calculated based on choice of gain, value of the maximum current to be sensed (I_{MAX}), and the power-supply voltage (V_S). When operating at the maximum current, the output voltage must not exceed the positive output swing specification, V_{SP} . Using [方程式 6](#), for the given design parameters the maximum value for R_{SENSE} is calculated to be $1.321\text{ k}\Omega$.

$$R_{SENSE} < \frac{V_{SP}}{I_{MAX} \times GAIN} \quad (6)$$

However, because this value exceeds the maximum recommended value for R_{SENSE} , a resistance value of $1\text{ k}\Omega$ must be used. When operating at the minimum current value, I_{MIN} the output voltage must be greater than the swing to GND (V_{SN}), specification. For this example, the output voltage at the minimum current is calculated using [方程式 7](#) to be 25 mV , which is greater than the value for V_{SN} .

$$V_{OUTMIN} = I_{MIN} \times R_{SENSE} \times GAIN \quad (7)$$

8.2.3 Application Curve

[图 8-7](#) shows the output of the device under the conditions given in [表 8-1](#) and with $R_{SENSE} = 1\text{ k}\Omega$.



图 8-7. Typical Application DC Transfer Function

9 Power Supply Recommendations

The input circuitry of the INA186-Q1 accurately measures beyond the power-supply voltage, V_S . For example, V_S can be 5 V , whereas the bus supply voltage at $IN+$ and $IN-$ can be as high as 40 V . However, the output voltage range of the OUT pin is limited by the voltage on the VS pin. The INA186-Q1 also withstands the full differential input signal range up to 40 V at the $IN+$ and $IN-$ input pins, regardless of whether the device has power applied at the VS pin. There is no sequencing requirement for V_S and V_{IN+} or V_{IN-} .

10 Layout

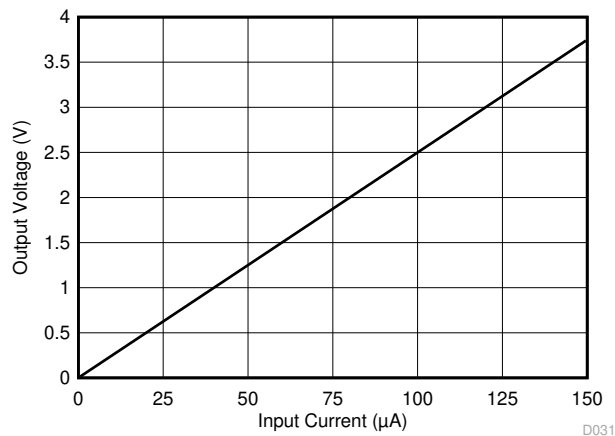
10.1 Layout Guidelines

- Connect the input pins to the sensing resistor using a Kelvin or 4-wire connection. This connection technique makes sure that only the current-sensing resistor impedance is detected between the input pins. Poor routing of the current-sensing resistor commonly results in additional resistance present between the input pins. Given the very low ohmic value of the current resistor, any additional high-current carrying impedance can cause significant measurement errors.
- Place the power-supply bypass capacitor as close as possible to the device power supply and ground pins. The recommended value of this bypass capacitor is 0.1 μF . Additional decoupling capacitance can be added to compensate for noisy or high-impedance power supplies.
- When routing the connections from the current-sense resistor to the device, keep the trace lengths as short as possible. The input filter capacitor C_F should be placed as close as possible to the input pins of the device.

10.2 Layout Examples



图 10-1. Recommended Layout for SC70 (DCK) Package



图 10-2. Recommended Layout for SOT-23 (DDF) Package

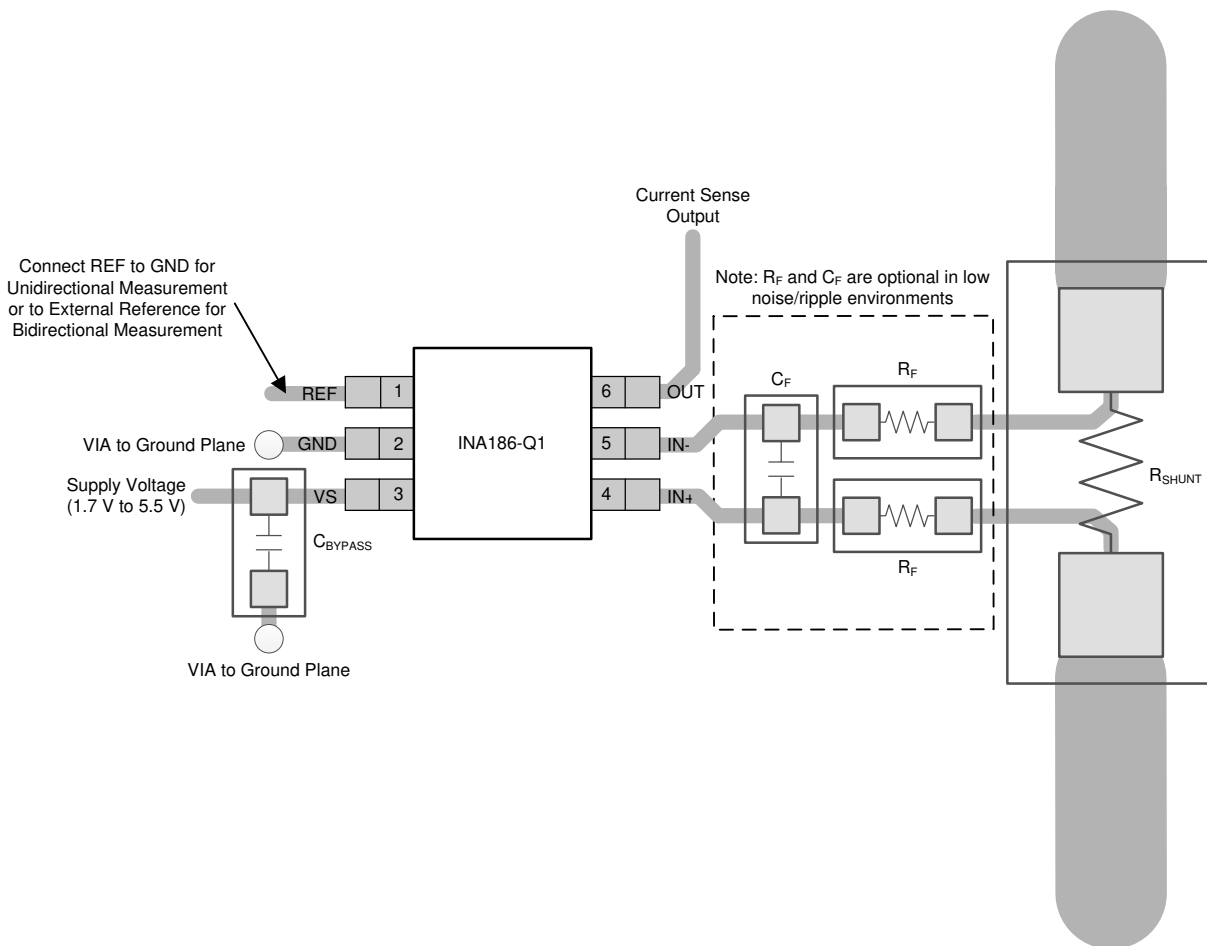

图 10-3. Recommended Layout for SOT23-5 (DBV) Package

11 Device and Documentation Support

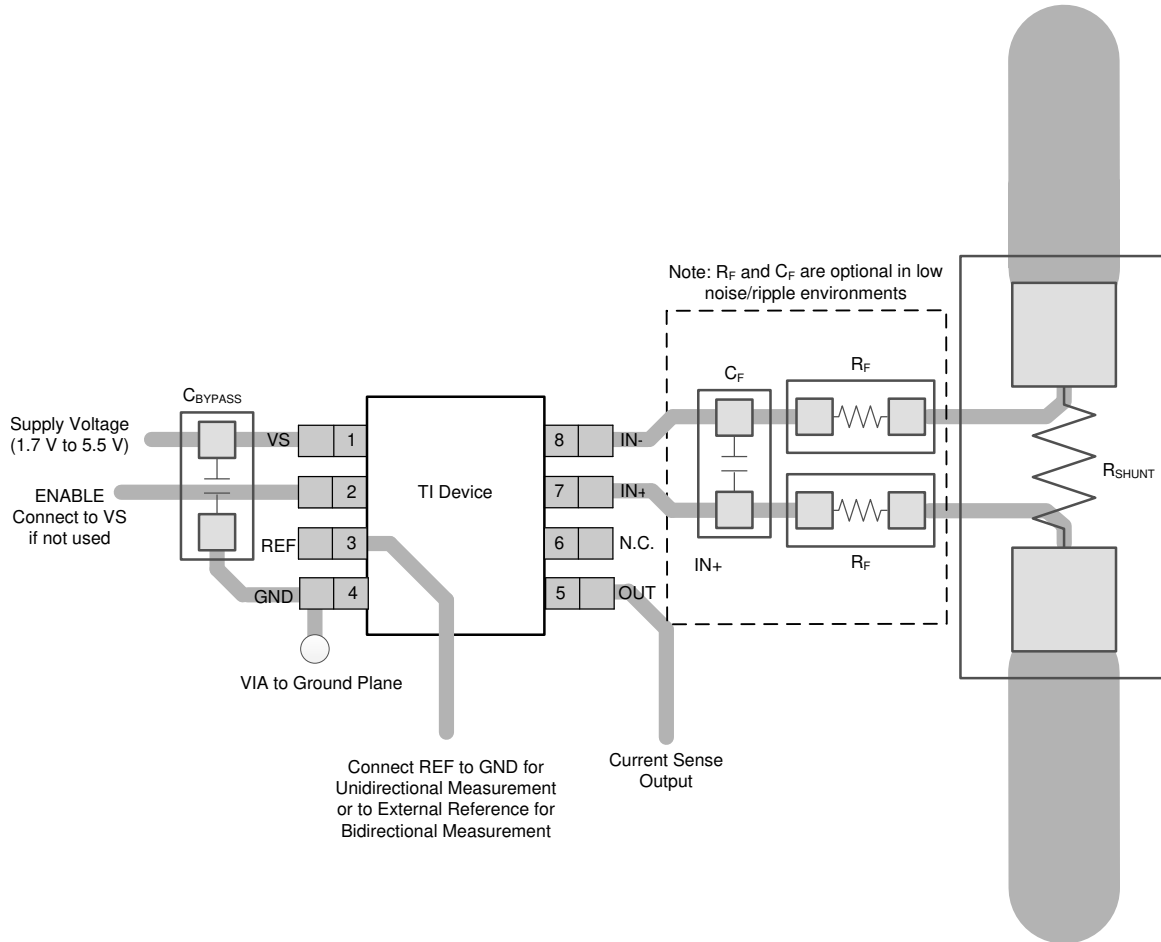
11.1 Documentation Support

11.1.1 Related Documentation

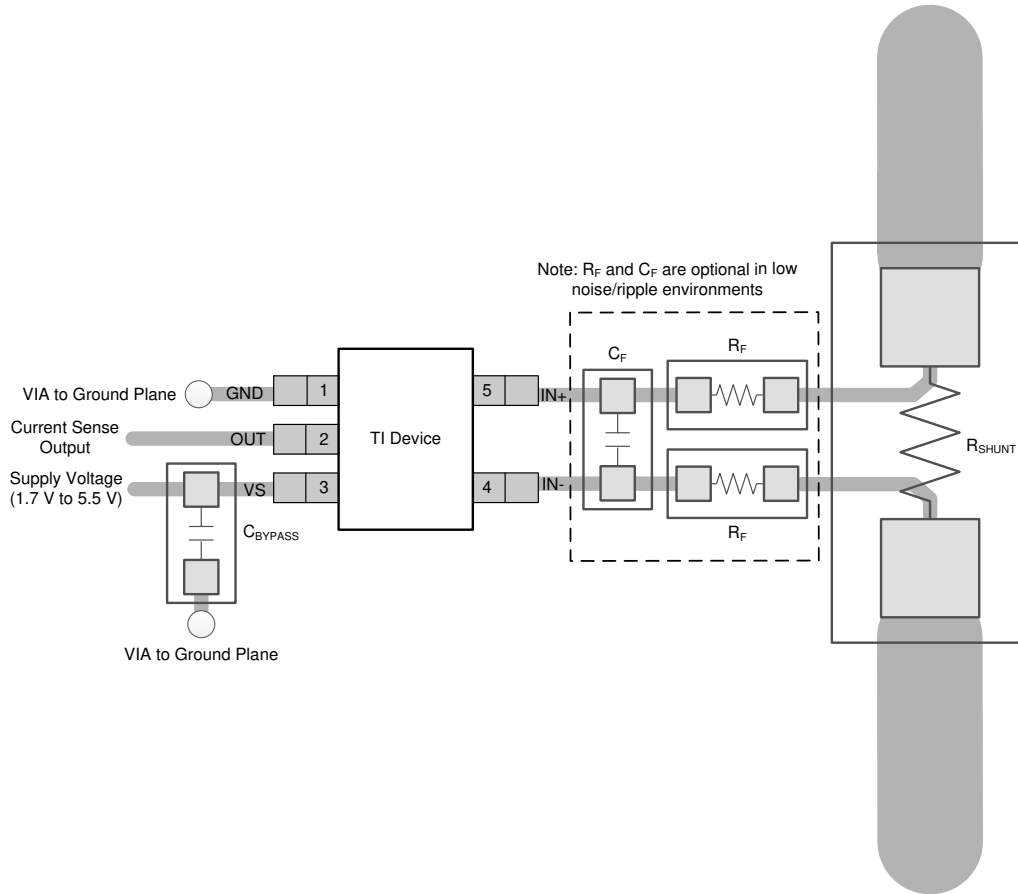
For related documentation see the following: Texas Instruments, [INA186EVM user's guide](#)

11.2 接收文档更新通知

要接收文档更新通知，请导航至 [ti.com](https://www.ti.com) 上的器件产品文件夹。点击 [订阅更新](#) 进行注册，即可每周接收产品信息更改摘要。有关更改的详细信息，请查看任何已修订文档中包含的修订历史记录。

11.3 支持资源

[TI E2E™ 支持论坛](#) 是工程师的重要参考资料，可直接从专家获得快速、经过验证的解答和设计帮助。搜索现有解答或提出自己的问题可获得所需的快速设计帮助。

链接的内容由各个贡献者“按原样”提供。这些内容并不构成 TI 技术规范，并且不一定反映 TI 的观点；请参阅 TI 的《[使用条款](#)》。

11.4 Trademarks

TI E2E™ is a trademark of Texas Instruments.

所有商标均为其各自所有者的财产。

11.5 Electrostatic Discharge Caution



This integrated circuit can be damaged by ESD. Texas Instruments recommends that all integrated circuits be handled with appropriate precautions. Failure to observe proper handling and installation procedures can cause damage.

ESD damage can range from subtle performance degradation to complete device failure. Precision integrated circuits may be more susceptible to damage because very small parametric changes could cause the device not to meet its published specifications.

11.6 术语表

[TI 术语表](#) 本术语表列出并解释了术语、首字母缩略词和定义。

12 Mechanical, Packaging, and Orderable Information

The following pages include mechanical, packaging, and orderable information. This information is the most current data available for the designated devices. This data is subject to change without notice and revision of this document. For browser-based versions of this data sheet, refer to the left-hand navigation.

PACKAGING INFORMATION

Orderable Device	Status (1)	Package Type	Package Drawing	Pins	Package Qty	Eco Plan (2)	Lead finish/ Ball material (6)	MSL Peak Temp (3)	Op Temp (°C)	Device Marking (4/5)	Samples
INA186A1QDBVRQ1	ACTIVE	SOT-23	DBV	5	3000	RoHS & Green	NIPDAU	Level-1-260C-UNLIM	-40 to 125	1ZSY	Samples
INA186A1QDCKRQ1	ACTIVE	SC70	DCK	6	3000	RoHS & Green	NIPDAU	Level-2-260C-1 YEAR	-40 to 125	1EX	Samples
INA186A1QDDFRQ1	ACTIVE	SOT-23-THIN	DDF	8	3000	RoHS & Green	NIPDAU	Level-1-260C-UNLIM	-40 to 125	2C6W	Samples
INA186A2QDBVRQ1	ACTIVE	SOT-23	DBV	5	3000	RoHS & Green	NIPDAU	Level-1-260C-UNLIM	-40 to 125	1ZTY	Samples
INA186A2QDCKRQ1	ACTIVE	SC70	DCK	6	3000	RoHS & Green	NIPDAU	Level-2-260C-1 YEAR	-40 to 125	1EZ	Samples
INA186A2QDDFRQ1	ACTIVE	SOT-23-THIN	DDF	8	3000	RoHS & Green	NIPDAU	Level-1-260C-UNLIM	-40 to 125	2C7W	Samples
INA186A3QDBVRQ1	ACTIVE	SOT-23	DBV	5	3000	RoHS & Green	NIPDAU	Level-1-260C-UNLIM	-40 to 125	1ZUY	Samples
INA186A3QDCKRQ1	ACTIVE	SC70	DCK	6	3000	RoHS & Green	NIPDAU	Level-2-260C-1 YEAR	-40 to 125	1F1	Samples
INA186A3QDDFRQ1	ACTIVE	SOT-23-THIN	DDF	8	3000	RoHS & Green	NIPDAU	Level-1-260C-UNLIM	-40 to 125	2C8W	Samples
INA186A4QDBVRQ1	ACTIVE	SOT-23	DBV	5	3000	RoHS & Green	NIPDAU	Level-1-260C-UNLIM	-40 to 125	1ZVY	Samples
INA186A4QDCKRQ1	ACTIVE	SC70	DCK	6	3000	RoHS & Green	NIPDAU	Level-2-260C-1 YEAR	-40 to 125	1F2	Samples
INA186A4QDDFRQ1	ACTIVE	SOT-23-THIN	DDF	8	3000	RoHS & Green	NIPDAU	Level-1-260C-UNLIM	-40 to 125	2C9W	Samples
INA186A5QDBVRQ1	ACTIVE	SOT-23	DBV	5	3000	RoHS & Green	NIPDAU	Level-1-260C-UNLIM	-40 to 125	1ZWY	Samples
INA186A5QDCKRQ1	ACTIVE	SC70	DCK	6	3000	RoHS & Green	NIPDAU	Level-2-260C-1 YEAR	-40 to 125	1F3	Samples
INA186A5QDDFRQ1	ACTIVE	SOT-23-THIN	DDF	8	3000	RoHS & Green	NIPDAU	Level-1-260C-UNLIM	-40 to 125	2CAW	Samples

(1) The marketing status values are defined as follows:

ACTIVE: Product device recommended for new designs.

LIFEBUY: TI has announced that the device will be discontinued, and a lifetime-buy period is in effect.

NRND: Not recommended for new designs. Device is in production to support existing customers, but TI does not recommend using this part in a new design.

PREVIEW: Device has been announced but is not in production. Samples may or may not be available.

OBSOLETE: TI has discontinued the production of the device.

(2) **RoHS:** TI defines "RoHS" to mean semiconductor products that are compliant with the current EU RoHS requirements for all 10 RoHS substances, including the requirement that RoHS substance do not exceed 0.1% by weight in homogeneous materials. Where designed to be soldered at high temperatures, "RoHS" products are suitable for use in specified lead-free processes. TI may reference these types of products as "Pb-Free".

RoHS Exempt: TI defines "RoHS Exempt" to mean products that contain lead but are compliant with EU RoHS pursuant to a specific EU RoHS exemption.

Green: TI defines "Green" to mean the content of Chlorine (Cl) and Bromine (Br) based flame retardants meet JS709B low halogen requirements of <=1000ppm threshold. Antimony trioxide based flame retardants must also meet the <=1000ppm threshold requirement.

(3) MSL, Peak Temp. - The Moisture Sensitivity Level rating according to the JEDEC industry standard classifications, and peak solder temperature.

(4) There may be additional marking, which relates to the logo, the lot trace code information, or the environmental category on the device.

(5) Multiple Device Markings will be inside parentheses. Only one Device Marking contained in parentheses and separated by a "~" will appear on a device. If a line is indented then it is a continuation of the previous line and the two combined represent the entire Device Marking for that device.

(6) Lead finish/Ball material - Orderable Devices may have multiple material finish options. Finish options are separated by a vertical ruled line. Lead finish/Ball material values may wrap to two lines if the finish value exceeds the maximum column width.

Important Information and Disclaimer:The information provided on this page represents TI's knowledge and belief as of the date that it is provided. TI bases its knowledge and belief on information provided by third parties, and makes no representation or warranty as to the accuracy of such information. Efforts are underway to better integrate information from third parties. TI has taken and continues to take reasonable steps to provide representative and accurate information but may not have conducted destructive testing or chemical analysis on incoming materials and chemicals. TI and TI suppliers consider certain information to be proprietary, and thus CAS numbers and other limited information may not be available for release.

In no event shall TI's liability arising out of such information exceed the total purchase price of the TI part(s) at issue in this document sold by TI to Customer on an annual basis.

OTHER QUALIFIED VERSIONS OF INA186-Q1 :

- Catalog : [INA186](#)

NOTE: Qualified Version Definitions:

- Catalog - TI's standard catalog product

TAPE AND REEL INFORMATION

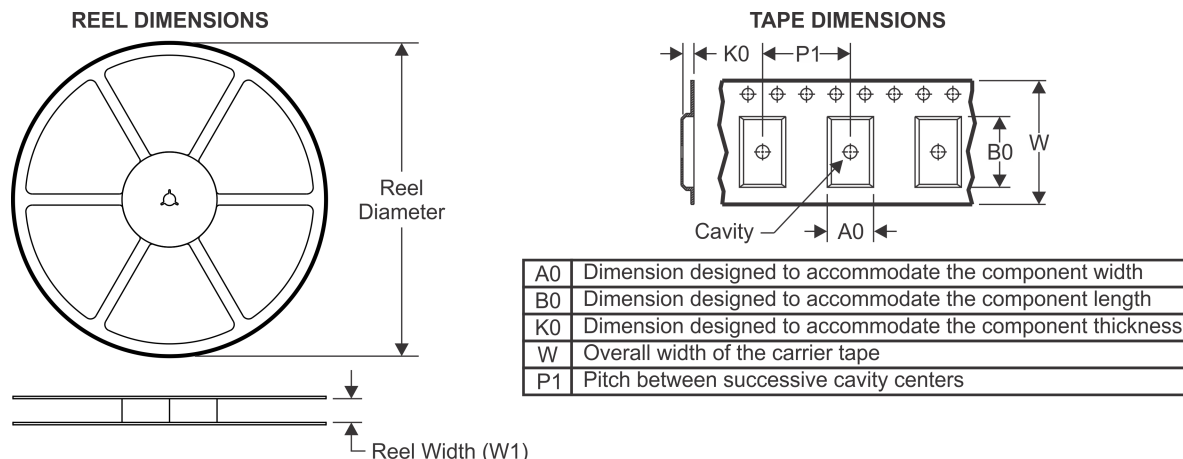

QUADRANT ASSIGNMENTS FOR PIN 1 ORIENTATION IN TAPE

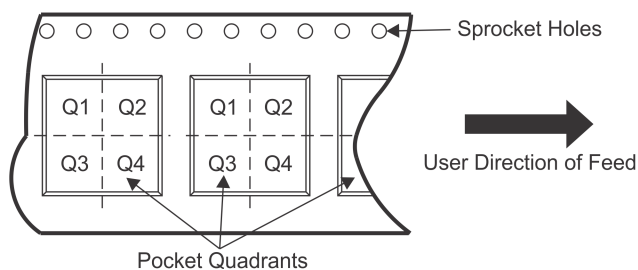

*All dimensions are nominal

Device	Package Type	Package Drawing	Pins	SPQ	Reel Diameter (mm)	Reel Width W1 (mm)	A0 (mm)	B0 (mm)	K0 (mm)	P1 (mm)	W (mm)	Pin1 Quadrant
INA186A1QDBVRQ1	SOT-23	DBV	5	3000	180.0	8.4	3.23	3.17	1.37	4.0	8.0	Q3
INA186A1QDCKRQ1	SC70	DCK	6	3000	180.0	8.4	2.47	2.3	1.25	4.0	8.0	Q3
INA186A1QDDFRQ1	SOT-23-THIN	DDF	8	3000	180.0	8.4	3.2	3.2	1.4	4.0	8.0	Q3
INA186A2QDBVRQ1	SOT-23	DBV	5	3000	180.0	8.4	3.23	3.17	1.37	4.0	8.0	Q3
INA186A2QDCKRQ1	SC70	DCK	6	3000	180.0	8.4	2.47	2.3	1.25	4.0	8.0	Q3
INA186A2QDDFRQ1	SOT-23-THIN	DDF	8	3000	180.0	8.4	3.2	3.2	1.4	4.0	8.0	Q3
INA186A3QDBVRQ1	SOT-23	DBV	5	3000	180.0	8.4	3.23	3.17	1.37	4.0	8.0	Q3
INA186A3QDCKRQ1	SC70	DCK	6	3000	180.0	8.4	2.47	2.3	1.25	4.0	8.0	Q3
INA186A3QDDFRQ1	SOT-23-THIN	DDF	8	3000	180.0	8.4	3.2	3.2	1.4	4.0	8.0	Q3
INA186A4QDBVRQ1	SOT-23	DBV	5	3000	180.0	8.4	3.23	3.17	1.37	4.0	8.0	Q3
INA186A4QDCKRQ1	SC70	DCK	6	3000	180.0	8.4	2.47	2.3	1.25	4.0	8.0	Q3
INA186A4QDDFRQ1	SOT-23-THIN	DDF	8	3000	180.0	8.4	3.2	3.2	1.4	4.0	8.0	Q3
INA186A5QDBVRQ1	SOT-23	DBV	5	3000	180.0	8.4	3.23	3.17	1.37	4.0	8.0	Q3
INA186A5QDCKRQ1	SC70	DCK	6	3000	180.0	8.4	2.47	2.3	1.25	4.0	8.0	Q3
INA186A5QDDFRQ1	SOT-	DDF	8	3000	180.0	8.4	3.2	3.2	1.4	4.0	8.0	Q3

Device	Package Type	Package Drawing	Pins	SPQ	Reel Diameter (mm)	Reel Width W1 (mm)	A0 (mm)	B0 (mm)	K0 (mm)	P1 (mm)	W (mm)	Pin1 Quadrant
	23-THIN											

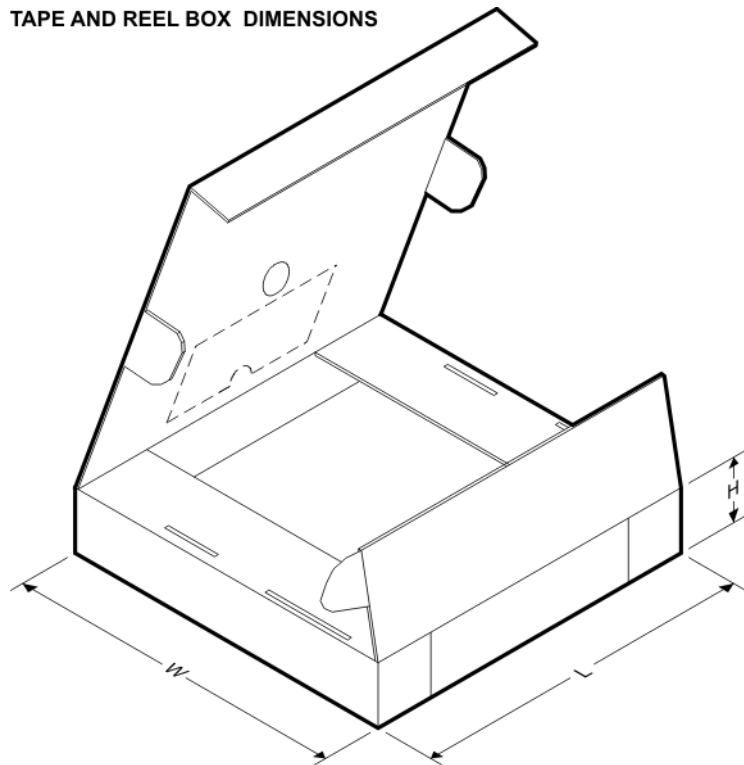
TAPE AND REEL BOX DIMENSIONS

*All dimensions are nominal

Device	Package Type	Package Drawing	Pins	SPQ	Length (mm)	Width (mm)	Height (mm)
INA186A1QDBVRQ1	SOT-23	DBV	5	3000	183.0	183.0	20.0
INA186A1QDCKRQ1	SC70	DCK	6	3000	213.0	191.0	35.0
INA186A1QDDFRQ1	SOT-23-THIN	DDF	8	3000	210.0	185.0	35.0
INA186A2QDBVRQ1	SOT-23	DBV	5	3000	183.0	183.0	20.0
INA186A2QDCKRQ1	SC70	DCK	6	3000	213.0	191.0	35.0
INA186A2QDDFRQ1	SOT-23-THIN	DDF	8	3000	210.0	185.0	35.0
INA186A3QDBVRQ1	SOT-23	DBV	5	3000	183.0	183.0	20.0
INA186A3QDCKRQ1	SC70	DCK	6	3000	213.0	191.0	35.0
INA186A3QDDFRQ1	SOT-23-THIN	DDF	8	3000	210.0	185.0	35.0
INA186A4QDBVRQ1	SOT-23	DBV	5	3000	183.0	183.0	20.0
INA186A4QDCKRQ1	SC70	DCK	6	3000	213.0	191.0	35.0
INA186A4QDDFRQ1	SOT-23-THIN	DDF	8	3000	210.0	185.0	35.0
INA186A5QDBVRQ1	SOT-23	DBV	5	3000	183.0	183.0	20.0
INA186A5QDCKRQ1	SC70	DCK	6	3000	213.0	191.0	35.0
INA186A5QDDFRQ1	SOT-23-THIN	DDF	8	3000	210.0	185.0	35.0

DCK (R-PDSO-G6)

PLASTIC SMALL-OUTLINE PACKAGE

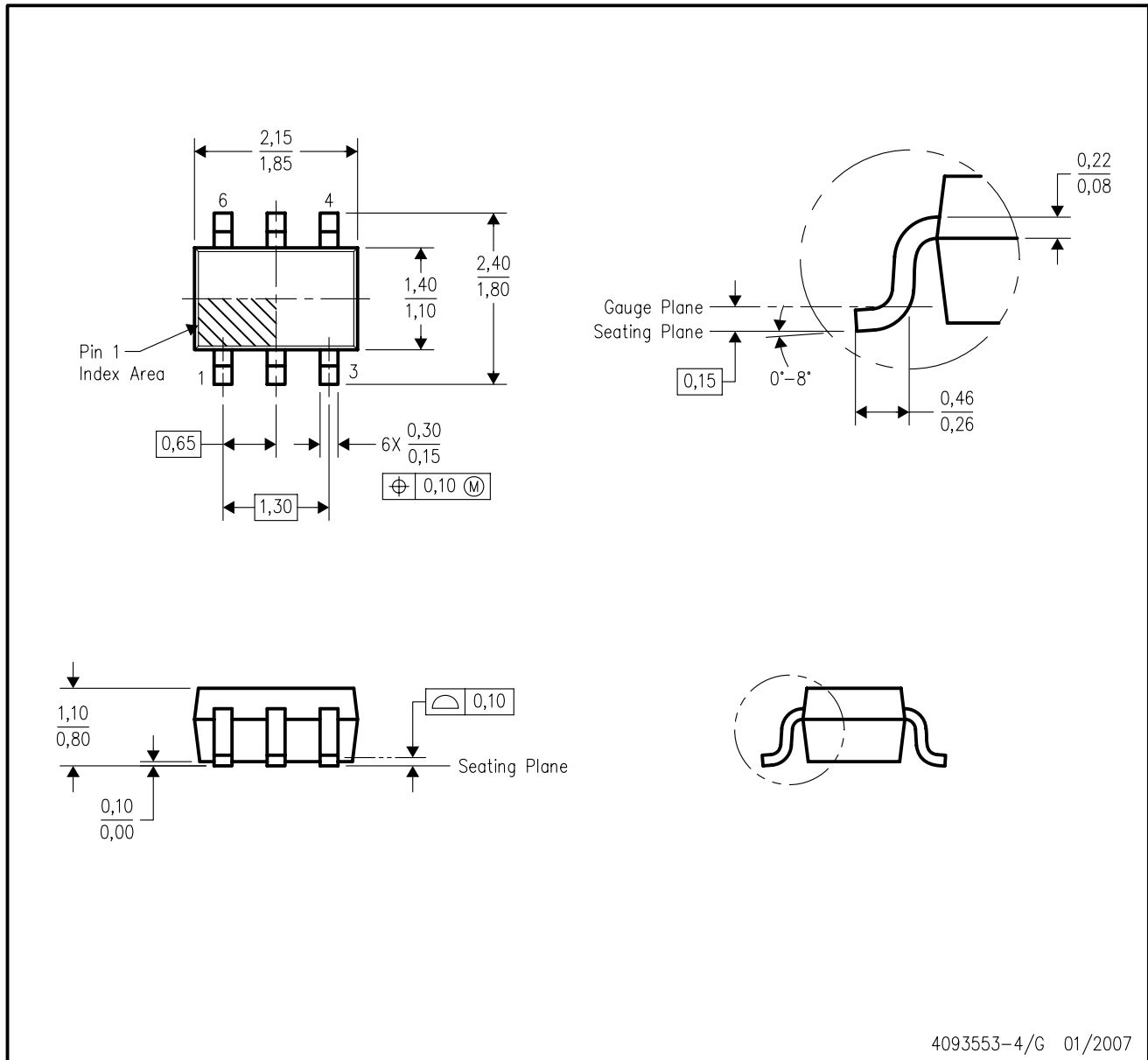

- NOTES:
- A. All linear dimensions are in millimeters.
 - B. This drawing is subject to change without notice.
 - C. Body dimensions do not include mold flash or protrusion. Mold flash and protrusion shall not exceed 0.15 per side.
 - D. Falls within JEDEC MO-203 variation AB.

DCK (R-PDSO-G6)

PLASTIC SMALL OUTLINE

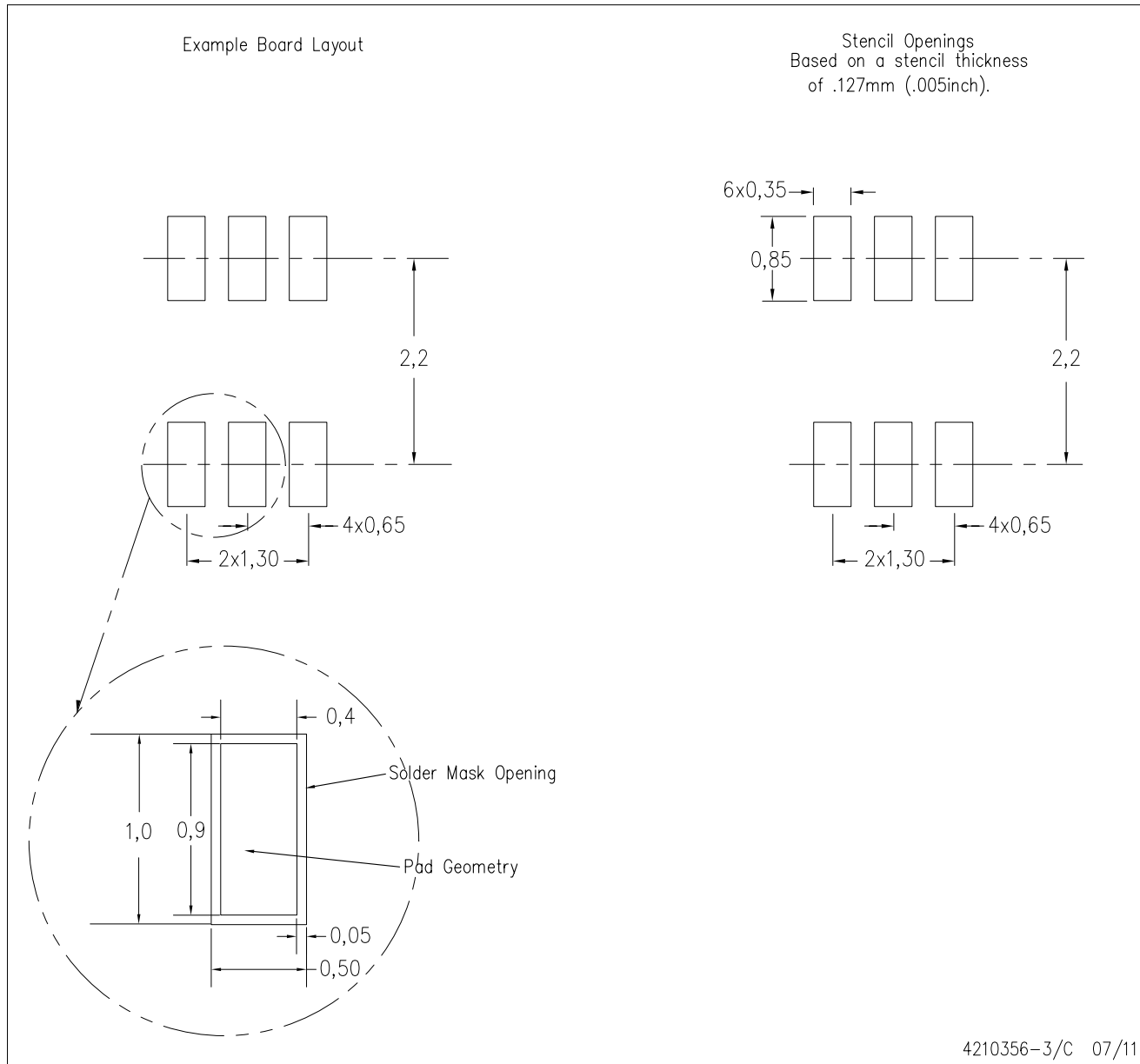

- NOTES:
- All linear dimensions are in millimeters.
 - This drawing is subject to change without notice.
 - Customers should place a note on the circuit board fabrication drawing not to alter the center solder mask defined pad.
 - Publication IPC-7351 is recommended for alternate designs.
 - Laser cutting apertures with trapezoidal walls and also rounding corners will offer better paste release. Customers should contact their board assembly site for stencil design recommendations. Example stencil design based on a 50% volumetric metal load solder paste. Refer to IPC-7525 for other stencil recommendations.

DDF0008A

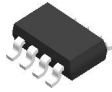

PACKAGE OUTLINE

SOT-23 - 1.1 mm max height

PLASTIC SMALL OUTLINE

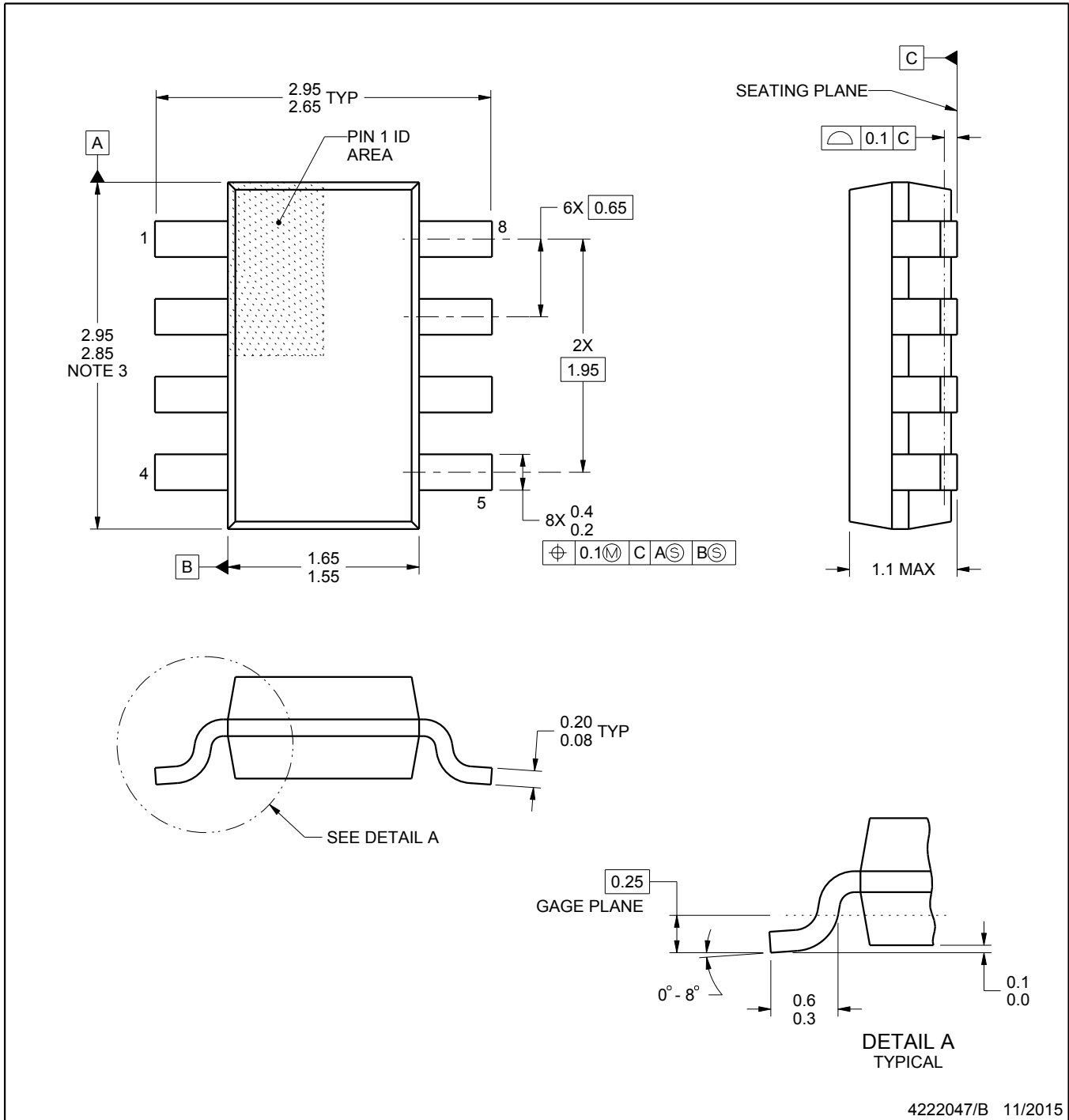

4222047/B 11/2015

NOTES:

1. All linear dimensions are in millimeters. Any dimensions in parenthesis are for reference only. Dimensioning and tolerancing per ASME Y14.5M.
2. This drawing is subject to change without notice.
3. This dimension does not include mold flash, protrusions, or gate burrs. Mold flash, protrusions, or gate burrs shall not exceed 0.15 mm per side.

EXAMPLE BOARD LAYOUT

DDF0008A

SOT-23 - 1.1 mm max height

PLASTIC SMALL OUTLINE

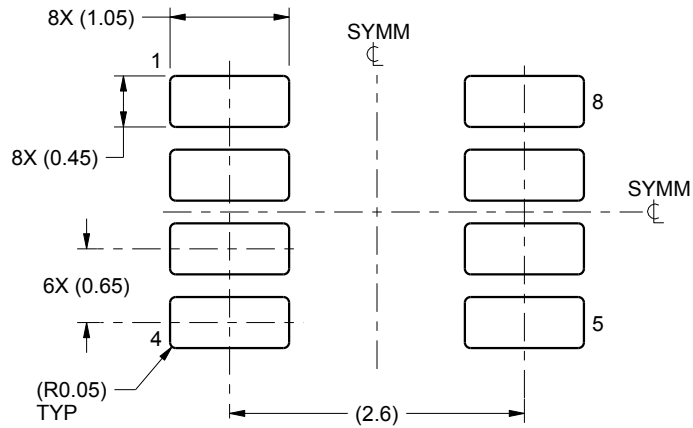

LAND PATTERN EXAMPLE
SCALE:15X

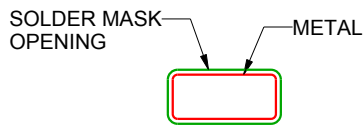

NON SOLDER MASK
DEFINED

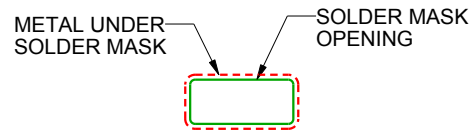

SOLDER MASK
DEFINED

SOLDER MASK DETAILS

4222047/B 11/2015

NOTES: (continued)

4. Publication IPC-7351 may have alternate designs.
5. Solder mask tolerances between and around signal pads can vary based on board fabrication site.

EXAMPLE STENCIL DESIGN

DDF0008A

SOT-23 - 1.1 mm max height

PLASTIC SMALL OUTLINE

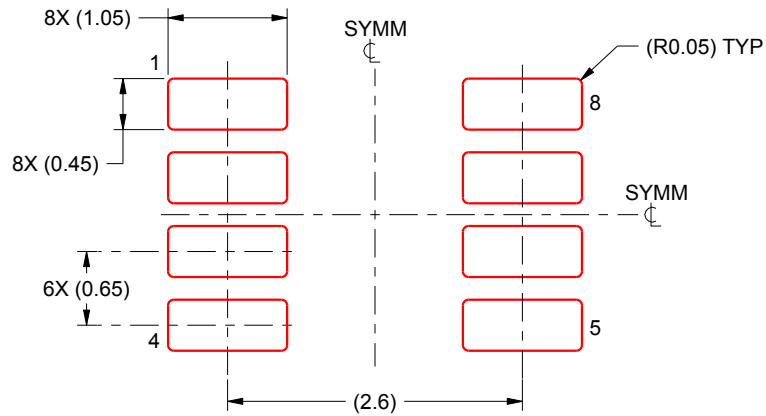

SOLDER PASTE EXAMPLE
BASED ON 0.125 mm THICK STENCIL
SCALE:15X

4222047/B 11/2015

NOTES: (continued)

6. Laser cutting apertures with trapezoidal walls and rounded corners may offer better paste release. IPC-7525 may have alternate design recommendations.
7. Board assembly site may have different recommendations for stencil design.

EXAMPLE BOARD LAYOUT

DBV0005A

SOT-23 - 1.45 mm max height

SMALL OUTLINE TRANSISTOR

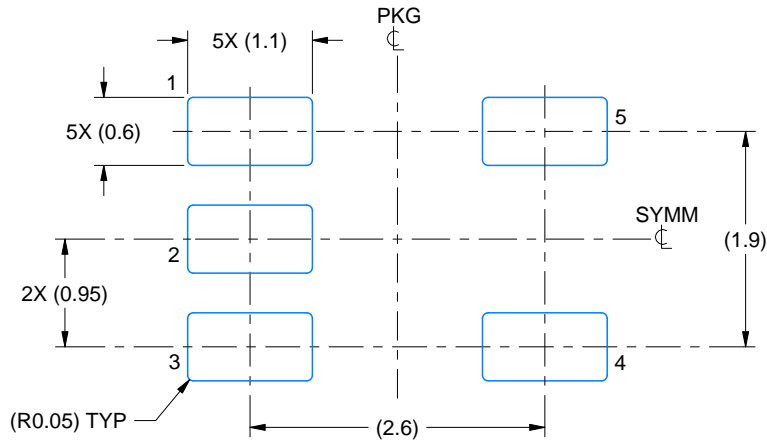

LAND PATTERN EXAMPLE
EXPOSED METAL SHOWN
SCALE:15X

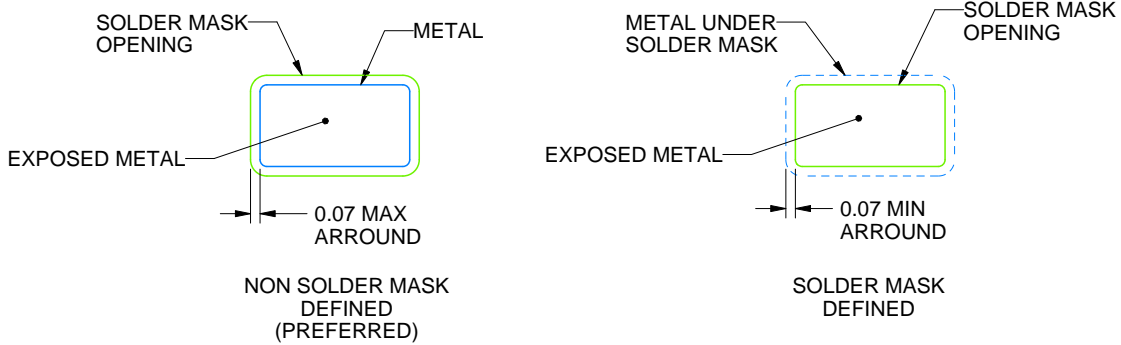

SOLDER MASK DETAILS

4214839/F 06/2021

NOTES: (continued)

- 5. Publication IPC-7351 may have alternate designs.
- 6. Solder mask tolerances between and around signal pads can vary based on board fabrication site.

EXAMPLE STENCIL DESIGN

DBV0005A

SOT-23 - 1.45 mm max height

SMALL OUTLINE TRANSISTOR

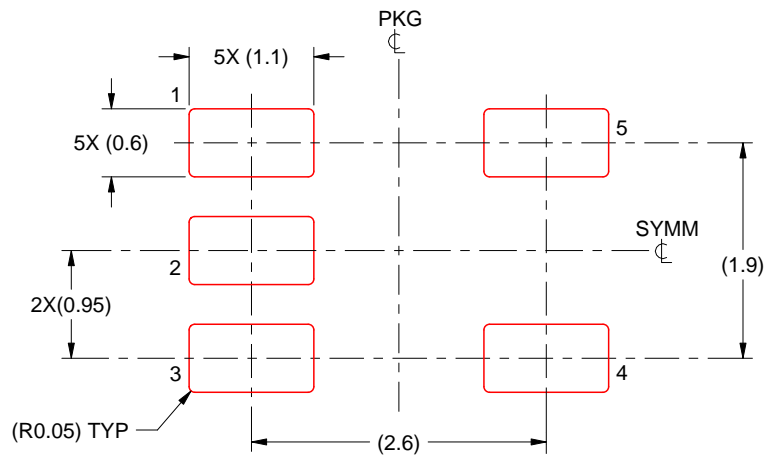

SOLDER PASTE EXAMPLE
BASED ON 0.125 mm THICK STENCIL
SCALE:15X

4214839/F 06/2021

NOTES: (continued)

7. Laser cutting apertures with trapezoidal walls and rounded corners may offer better paste release. IPC-7525 may have alternate design recommendations.
8. Board assembly site may have different recommendations for stencil design.

重要声明和免责声明

TI“按原样”提供技术和可靠性数据（包括数据表）、设计资源（包括参考设计）、应用或其他设计建议、网络工具、安全信息和其他资源，不保证没有瑕疵且不做任何明示或暗示的担保，包括但不限于对适销性、某特定用途方面的适用性或不侵犯任何第三方知识产权的暗示担保。

这些资源可供使用 TI 产品进行设计的熟练开发人员使用。您将自行承担以下全部责任：(1) 针对您的应用选择合适的 TI 产品，(2) 设计、验证并测试您的应用，(3) 确保您的应用满足相应标准以及任何其他功能安全、信息安全、监管或其他要求。

这些资源如有变更，恕不另行通知。TI 授权您仅可将这些资源用于研发本资源所述的 TI 产品的应用。严禁对这些资源进行其他复制或展示。您无权使用任何其他 TI 知识产权或任何第三方知识产权。您应全额赔偿因在这些资源的使用中对 TI 及其代表造成的任何索赔、损害、成本、损失和债务，TI 对此概不负责。

TI 提供的产品受 [TI 的销售条款](#) 或 [ti.com](#) 上其他适用条款/TI 产品随附的其他适用条款的约束。TI 提供这些资源并不会扩展或以其他方式更改 TI 针对 TI 产品发布的适用的担保或担保免责声明。

TI 反对并拒绝您可能提出的任何其他或不同的条款。

邮寄地址：Texas Instruments, Post Office Box 655303, Dallas, Texas 75265

Copyright © 2022，德州仪器 (TI) 公司