

## INAx126 MicroPower 仪表放大器

### 1 特性

- 低静态电流：175  $\mu$ A/channel
- 宽电源电压范围： $\pm 1.35$ V 至  $\pm 18$  V
- 低失调电压：250 $\mu$ V (最大值)
- 低温漂：3  $\mu$ V/ $^{\circ}$ C (最大值)
- 低噪声：35nV/ $\sqrt{\text{Hz}}$
- 低输入偏置电流：25nA (最大值)
- 温度范围：-40 $^{\circ}$ C 至 +85 $^{\circ}$ C
- 多种封装选项：
  - 单通道：
    - INA126P/PA 8 引脚 PDIP (P)
    - INA126U/UA 8 引脚 SOIC (D)
    - INA126E/EA 8 引脚 VSSOP (DGK)
  - 双通道：
    - INA2126P/PA 16 引脚 PDIP (N)
    - INA2126U/UA 16 引脚 SOIC (D)
    - INA2126E/EA 16 引脚 SSOP (DBQ)

### 2 应用

- 液位变送器
- 流量变送器
- 多参数患者监护仪
- 混合模块 ( AI、AO、DI、DO )
- 交流充电 ( 桩 ) 站
- 输液泵
- 心电图 ( ECG )

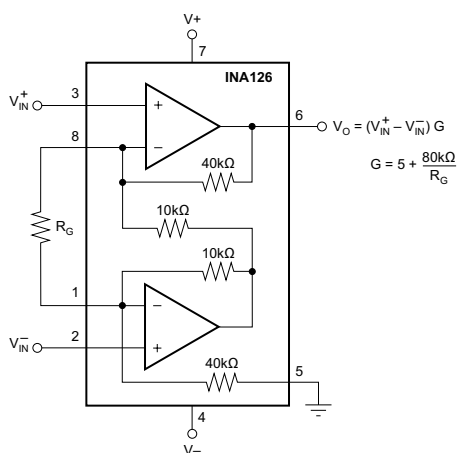

简化版原理图：INA126

### 3 说明

INA126 和 INA2126 (INAx126) 是用于精确、低噪声、差分信号采集的精密仪表放大器。这些器件均采用双运算放大器设计，具有低静态电流 (175  $\mu$ A/通道)，可提供出色的瞬态性能。由于这些特性再加上  $\pm 1.35$ V 至  $\pm 18$ V 的宽工作电压范围，因此 INAx126 非常适合便携式仪表和数据采集系统。

可通过单个外部电阻器在 5V/V 到 10000V/V 范围内设置增益。精密输入电路提供低失调电压 (250  $\mu$ V, 最大值)、低失调电压漂移 (3  $\mu$ V/ $^{\circ}$ C, 最大值) 和出色的共模抑制。

所有版本的额定工作温度范围均为 -40 $^{\circ}$ C 至 +85 $^{\circ}$ C 工业温度范围。

#### 器件信息

器件型号	封装 <sup>(1)</sup>	封装尺寸 (标称值)
INA126	PDIP (8)	6.35mm $\times$ 9.81mm
	SOIC (8)	3.91mm $\times$ 4.90mm
	VSSOP (8)	3.00mm $\times$ 3.00mm
INA2126	PDIP (16)	6.35mm $\times$ 19.30mm
	SOIC (16)	3.91mm $\times$ 9.90mm
	SSOP (16)	3.90mm $\times$ 4.90mm

(1) 如需了解所有可用封装，请参阅数据表末尾的可订购产品附录。

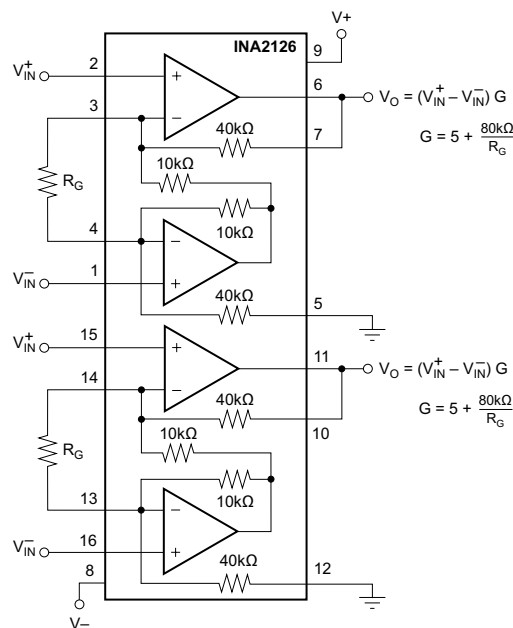

简化版原理图：INA2126



## Table of Contents

<b>1 特性</b> .....	<b>1</b>	<b>8 Application and Implementation</b> .....	<b>13</b>
<b>2 应用</b> .....	<b>1</b>	8.1 Application Information.....	13
<b>3 说明</b> .....	<b>1</b>	8.2 Typical Application.....	13
<b>4 Revision History</b> .....	<b>2</b>	<b>9 Power Supply Recommendations</b> .....	<b>17</b>
<b>5 Pin Configuration and Functions</b> .....	<b>3</b>	9.1 Low-Voltage Operation.....	17
<b>6 Specifications</b> .....	<b>5</b>	<b>10 Layout</b> .....	<b>18</b>
6.1 Absolute Maximum Ratings.....	5	10.1 Layout Guidelines.....	18
6.2 ESD Ratings.....	5	10.2 Layout Example.....	19
6.3 Recommended Operating Conditions.....	5	<b>11 Device and Documentation Support</b> .....	<b>20</b>
6.4 Thermal Information: INA126.....	6	11.1 Device Support.....	20
6.5 Thermal Information: INA2126.....	6	11.2 接收文档更新通知.....	20
6.6 Electrical Characteristics.....	7	11.3 支持资源.....	20
6.7 Typical Characteristics.....	9	11.4 Trademarks.....	20
<b>7 Detailed Description</b> .....	<b>12</b>	11.5 Electrostatic Discharge Caution.....	20
7.1 Overview.....	12	11.6 术语表.....	20
7.2 Functional Block Diagram.....	12	<b>12 Mechanical, Packaging, and Orderable Information</b> .....	<b>20</b>
7.3 Feature Description.....	12		
7.4 Device Functional Modes.....	12		

## 4 Revision History

注：以前版本的页码可能与当前版本的页码不同

<b>Changes from Revision B (December 2015) to Revision C (December 2021)</b>	<b>Page</b>
• 更新了整个文档中的表格、图和交叉参考的编号格式.....	1
• Added dual supply specification to <i>Absolute Maximum Ratings</i> .....	5
• Deleted redundant operating temperature and input common mode voltage specifications in <i>Recommended Operating Conditions</i> .....	5
• Added dual supply and specified temperature specifications in <i>Recommended Operating Conditions</i> .....	5
• Added proper signs for PSRR and input bias current specifications in <i>Electrical Characteristics</i> .....	7
• Deleted $V_O = 0$ V test condition of common-mode voltage specification in <i>Electrical Characteristics</i> .....	7
• Changed common-mode voltage specification from $\pm 11.25$ V minimum, to $- 11.25$ V minimum and $11.25$ V maximum, in <i>Electrical Characteristics</i> .....	7
• Changed minimum CMRR specification for INA126U/E, INA2126E from 83 dB to 80 dB in <i>Electrical Characteristics</i> .....	7
• Added typical input bias current specification of $\pm 10$ nA for INA126PA/UA/EA and INA2126PA/UA/EA in <i>Electrical Characteristics</i> .....	7
• Changed current noise specifications in <i>Electrical Characteristics</i> from $60$ fA/ $\sqrt{\text{Hz}}$ to $160$ fA/ $\sqrt{\text{Hz}}$ for $f = 1$ kHz, and from $2$ pApp to $7.3$ pApp for $f = 0.1$ Hz to $10$ Hz.....	7
• Changed test condition for short-circuit current specification in <i>Electrical Characteristics</i> from "Short circuit to ground" to "Continuous to $V_S / 2$ " for clarity.....	7
• Changed short-circuit current specification in <i>Electrical Characteristics</i> from $+10/-5$ mA to $\pm 5$ mA.....	7
• Deleted redundant voltage range, operating temperature range, and specification temperature range specifications from <i>Electrical Characteristics</i> .....	7
• Changed Figures 6-7, 6-10, 6-13, 6-14, 6-15, 6-16, 6-17.....	9
• Added Figure 6-11.....	9
<b>Changes from Revision A (August 2005) to Revision B (December 2015)</b>	<b>Page</b>
• 添加了 ESD 等级表、特性说明部分、器件功能模式、应用和实施部分、电源相关建议部分、布局部分、器件和文档支持部分以及机械、封装和可订购信息部分.....	1

## 5 Pin Configuration and Functions



图 5-1. INA126: P (8-Pin PDIP), D (8-Pin SOIC), and DGK (8-Pin VSSOP) Packages, Top View

表 5-1. Pin Functions: INA126

PIN		I/O	DESCRIPTION
NO.	NAME		
1, 8	$R_G$	—	Gain setting pin. For gains greater than 5 place a gain resistor between pin 1 and pin 8.
2	$V^-_{IN}$	I	Negative input
3	$V^+_{IN}$	I	Positive input
4	$V^-$	—	Negative supply
5	Ref	I	Reference input. This pin must be driven by a low impedance or connected to ground.
6	$V_O$	O	Output
7	$V^+$	—	Positive supply

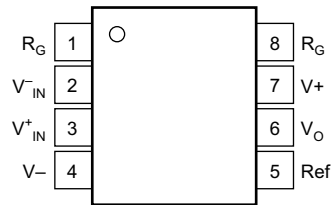

图 5-2. INA2126: N (16-Pin PDIP), D (16-Pin SOIC), and DBQ (16-Pin SSOP) Packages, Top View

表 5-2. Pin Functions: INA2126

PIN		I/O	DESCRIPTION
NO.	NAME		
1	$V^-_{INA}$	I	Negative input for amplifier A
2	$V^+_{INA}$	I	Positive input for amplifier A
3, 4	$R_{GA}$	—	Gain setting pin for amplifier A. For gains greater than 5 place a gain resistor between pin 3 and pin 4.
5	$Ref_A$	I	Reference input for amplifier A. This pin must be driven by a low impedance or connected to ground.
6	$V_{OA}$	O	Output of amplifier A
7	$Sense_A$	I	Feedback for amplifier A. Connect to $V_{OA}$ , amplifier A output.
8	$V^-$	—	Negative supply
9	$V^+$	—	Positive supply
10	$Sense_B$	I	Feedback for amplifier B. Connect to $V_{OB}$ , amplifier B output.
11	$V_{OB}$	O	Output of amplifier B
12	$Ref_B$	I	Reference input for amplifier B. This pin must be driven by a low impedance or connected to ground.
13, 14	$R_{GB}$	—	Gain setting pin for amplifier B. For gains greater than 5 place a gain resistor between pin 13 and pin 14.
15	$V^+_{INB}$	I	Positive input for amplifier B
16	$V^-_{INB}$	I	Negative input for amplifier B

## 6 Specifications

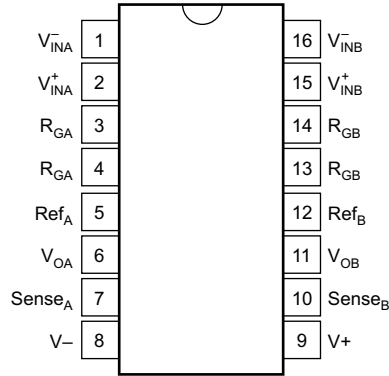
### 6.1 Absolute Maximum Ratings

over operating free-air temperature range (unless otherwise noted)<sup>(1)</sup>

		MIN	MAX	UNIT
V <sub>S</sub>	Supply voltage dual supply, V <sub>S</sub> = (V+) - (V-)		±18	V
	Supply voltage single supply, V <sub>S</sub> = (V+) - (V-)		36	
	Input signal voltage <sup>(2)</sup>	(V-) - 0.7	(V+) + 0.7	V
	Input signal current <sup>(2)</sup>		10	mA
	Output short-circuit <sup>(3)</sup>	Continuous		
T <sub>A</sub>	Operating Temperature	- 55	125	°C
	Lead temperature (soldering, 10 s)		300	°C
T <sub>stg</sub>	Storage Temperature	- 55	125	°C

- (1) Operation outside the Absolute Maximum Ratings may cause permanent device damage. Absolute Maximum Ratings do not imply functional operation of the device at these or any other conditions beyond those listed under Recommended Operating Conditions. If used outside the Recommended Operating Conditions but within the Absolute Maximum Ratings, the device may not be fully functional, and this may affect device reliability, functionality, performance, and shorten the device lifetime.
- (2) Input signal voltage is limited by internal diodes connected to power supplies. See [Input Protection](#).
- (3) Short-circuit to V<sub>S</sub> / 2.

### 6.2 ESD Ratings

			VALUE	UNIT
V <sub>(ESD)</sub>	Electrostatic discharge	Human-body model (HBM), per ANSI/ESDA/JEDEC JS-001 <sup>(1)</sup>	±500	V

- (1) JEDEC document JEP155 states that 500-V HBM allows safe manufacturing with a standard ESD control process.

### 6.3 Recommended Operating Conditions

over operating free-air temperature range (unless otherwise noted)

			MIN	TYP	MAX	UNIT
V <sub>S</sub>	Supply voltage	Single-supply	2.7	30	36	V
		Dual-supply	±1.35	±15	±18	
T <sub>A</sub>	Specified temperature		- 40		85	°C

### 6.4 Thermal Information: INA126

THERMAL METRIC <sup>(1)</sup>		INA126			UNIT
		PDIP	SOIC	VSSOP	
		8 PINS	8 PINS	8 PINS	
$R_{\theta JA}$	Junction-to-ambient thermal resistance	52.2	116.4	167.8	°C/W
$R_{\theta JC(top)}$	Junction-to-case (top) thermal resistance	41.6	62.4	60.9	°C/W
$R_{\theta JB}$	Junction-to-board thermal resistance	29.4	57.7	88.9	°C/W
$\psi_{JT}$	Junction-to-top characterization parameter	18.9	10.0	7.3	°C/W
$\psi_{JB}$	Junction-to-board characterization parameter	29.2	57.1	87.3	°C/W
$R_{\theta JC(bot)}$	Junction-to-case (bottom) thermal resistance	N/A	N/A	N/A	°C/W

(1) For more information about traditional and new thermal metrics, see the [Semiconductor and IC Package Thermal Metrics](#) application report.

### 6.5 Thermal Information: INA2126

THERMAL METRIC <sup>(1)</sup>		INA2126			UNIT
		PDIP	SOIC	SSOP	
		16 PINS	16 PINS	16 PINS	
$R_{\theta JA}$	Junction-to-ambient thermal resistance	39.3	76.2	115.8	°C/W
$R_{\theta JC(top)}$	Junction-to-case (top) thermal resistance	26.2	37.8	67.0	°C/W
$R_{\theta JB}$	Junction-to-board thermal resistance	20.1	33.5	58.3	°C/W
$\psi_{JT}$	Junction-to-top characterization parameter	10.7	7.5	19.9	°C/W
$\psi_{JB}$	Junction-to-board characterization parameter	19.9	33.3	57.9	°C/W
$R_{\theta JC(bot)}$	Junction-to-case (bottom) thermal resistance	N/A	N/A	N/A	°C/W

(1) For more information about traditional and new thermal metrics, see the [Semiconductor and IC Package Thermal Metrics](#) application report.

## 6.6 Electrical Characteristics

at  $T_A = 25^\circ\text{C}$ ,  $V_S = \pm 15\text{ V}$ ,  $R_L = 25\text{ k}\Omega$ ,  $V_{REF} = 0\text{ V}$ , and  $V_{CM} = V_S / 2$  (unless otherwise noted)

PARAMETER		TEST CONDITIONS		MIN	TYP	MAX	UNIT
<b>INPUT</b>							
$V_{OS}$	Offset voltage (RTI)	INA126P/U/E INA2126P/U/E			$\pm 100$	$\pm 250$	$\mu\text{V}$
		INA126PA/UA/EA INA2126PA/UA/EA			$\pm 150$	$\pm 500$	
	Offset voltage drift (RTI)	$T_A = -40^\circ\text{C}$ to $+85^\circ\text{C}$	INA126P/U/E INA2126P/U/E		$\pm 0.5$	$\pm 3$	$\mu\text{V}/^\circ\text{C}$
			INA126PA/UA/EA INA2126PA/UA/EA		$\pm 0.5$	$\pm 5$	
PSRR	Power-supply rejection ratio (RTI)	$V_S = \pm 1.35\text{ V}$ to $\pm 18\text{ V}$	INA126P/U/E INA2126P/U/E		$\pm 5$	$\pm 15$	$\text{uV/V}$
			INA126PA/UA/EA INA2126PA/UA/EA		$\pm 5$	$\pm 50$	
	Input impedance				$1 \parallel 4$		$\text{G}\Omega \parallel \text{pF}$
	Safe input voltage	$R_S = 0\ \Omega$		$(V^-) - 0.5$		$(V^+) + 0.5$	V
		$R_S = 1\text{ k}\Omega$		$(V^-) - 10$		$(V^+) + 10$	
$V_{CM}$	Common-mode voltage <sup>(1)</sup>			$-11.25$	$\pm 11.5$	$11.25$	V
	Channel separation (dual)	$G = 5, \text{dc}$			$130$		dB
CMRR	Common-mode rejection ratio	$R_S = 0\ \Omega, V_{CM} = \pm 11.25\text{ V}$	INA126P INA2126P		$83$	$94$	dB
			INA126U/E INA2126U/E		$80$	$94$	
			INA126PA/UA/EA INA2126PA/UA/EA		$74$	$83$	
<b>INPUT BIAS CURRENT</b>							
$I_B$	Input bias current	INA126P/U/E INA2126P/U/E			$\pm 10$	$\pm 25$	nA
		INA126PA/UA/EA INA2126PA/UA/EA			$\pm 10$	$\pm 50$	
	Input bias current drift	$T_A = -40^\circ\text{C}$ to $+85^\circ\text{C}$			$\pm 30$		$\text{pA}/^\circ\text{C}$
$I_{OS}$	Input offset current	INA126P/U/E INA2126P/U/E			$\pm 0.5$	$\pm 2$	nA
		INA126PA/UA/EA INA2126PA/UA/EA			$\pm 0.5$	$\pm 5$	nA
	Input offset current drift	$T_A = -40^\circ\text{C}$ to $+85^\circ\text{C}$			$\pm 10$		$\text{pA}/^\circ\text{C}$
<b>GAIN</b>							
	Gain equation				$5 + (80\text{ k}\Omega / R_G)$		V/V
G	Gain				$5$	$10000$	V/V
GE	Gain error	$G = 5, V_O = \pm 14\text{ V}$	INA126P/U/E INA2126P/U/E		$\pm 0.02$	$\pm 0.1$	%
			INA126PA/UA/EA INA2126PA/UA/EA		$\pm 0.02$	$\pm 0.18$	
		$G = 100, V_O = \pm 12\text{ V}$	INA126P/U/E INA2126P/U/E		$\pm 0.2$	$\pm 0.5$	
			INA126PA/UA/EA INA2126PA/UA/EA		$\pm 0.2$	$\pm 1$	
	Gain drift <sup>(2)</sup>	$T_A = -40^\circ\text{C}$ to $+85^\circ\text{C}$	$G = 5$		$\pm 2$	$\pm 10$	ppm/ $^\circ\text{C}$
			$G = 100$		$\pm 25$	$\pm 100$	
	Gain nonlinearity	$G = 100, V_O = \pm 14\text{ V}$			$\pm 0.002$	$\pm 0.012$	%

## 6.6 Electrical Characteristics (continued)

at  $T_A = 25^\circ\text{C}$ ,  $V_S = \pm 15\text{ V}$ ,  $R_L = 25\text{ k}\Omega$ ,  $V_{REF} = 0\text{ V}$ , and  $V_{CM} = V_S / 2$  (unless otherwise noted)

PARAMETER		TEST CONDITIONS		MIN	TYP	MAX	UNIT
<b>NOISE</b>							
$e_N$	Voltage noise	$f = 1\text{ kHz}$		35			$\text{nV}/\sqrt{\text{Hz}}$
		$f = 100\text{ Hz}$		35			
		$f_B = 10\text{ Hz}$		45			
		$f_B = 0.1\text{ Hz to }10\text{ Hz}$		0.7		$\mu\text{V}_{PP}$	
$I_n$	Current noise	$f = 1\text{ kHz}$		160			$\text{fA}/\sqrt{\text{Hz}}$
		$f_B = 0.1\text{ Hz to }10\text{ Hz}$		7.3			$\text{pA}_{PP}$
<b>OUTPUT</b>							
	Positive output voltage swing			$(V^+) - 0.9$	$(V^+) - 0.75$		V
	Negative output voltage swing			$(V^-) + 0.95$	$(V^-) + 0.8$		V
$I_{SC}$	Short-circuit current	Continuous to $V_S / 2$		$\pm 5$			mA
$C_L$	Load capacitance	Stable operation		1000			pF
<b>FREQUENCY RESPONSE</b>							
BW	Bandwidth, -3 dB	$G = 5$		200			kHz
		$G = 100$		9			
		$G = 500$		1.8			
SR	Slew rate	$G = 5, V_O = \pm 10\text{ V}$		0.4			V/ $\mu\text{s}$
$t_S$	Settling time	To 0.01%, $V_{STEP} = 10\text{ V}$	$G = 5$		30		$\mu\text{s}$
			$G = 100$		160		
			$G = 500$		1500		
	Overload recovery	50% input overload		4			$\mu\text{s}$
<b>POWER SUPPLY</b>							
$I_Q$	Quiescent current (per channel)	$I_O = 0\text{ mA}$		$\pm 175$	$\pm 200$		$\mu\text{A}$

- Input voltage range of the instrumentation amplifier input stage. The input range depends on the common-mode voltage, differential voltage, gain, and reference voltage. See *Typical Characteristic* curves.
- The values specified for  $G > 5$  do not include the effects of the external gain-setting resistor,  $R_G$ .

## 6.7 Typical Characteristics

at  $T_A = 25^\circ\text{C}$ ,  $V_S = \pm 15\text{ V}$  (unless otherwise noted)



图 6-1. Gain vs Frequency



图 6-2. Common-Mode Rejection vs Frequency

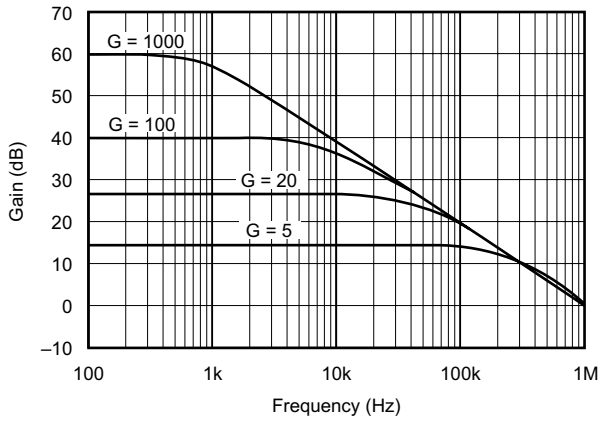

图 6-3. Positive Power Supply Rejection vs Frequency

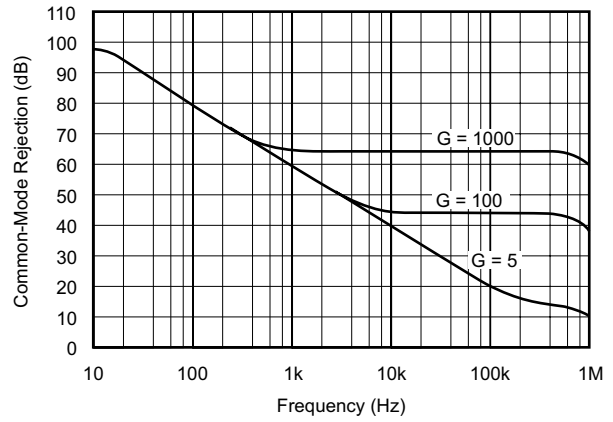

图 6-4. Negative Power Supply Rejection vs Frequency

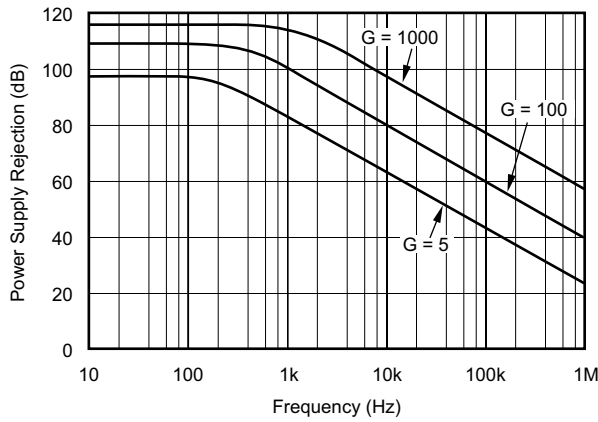

图 6-5. Input Common-Mode Voltage Range vs Output Voltage

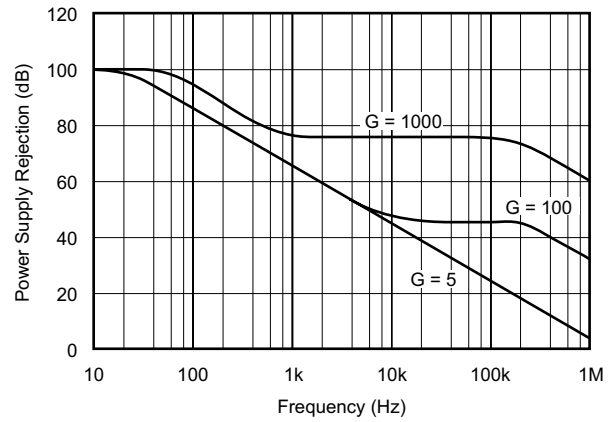

图 6-6. Input Common-Mode Voltage Range vs Output Voltage

### 6.7 Typical Characteristics (continued)

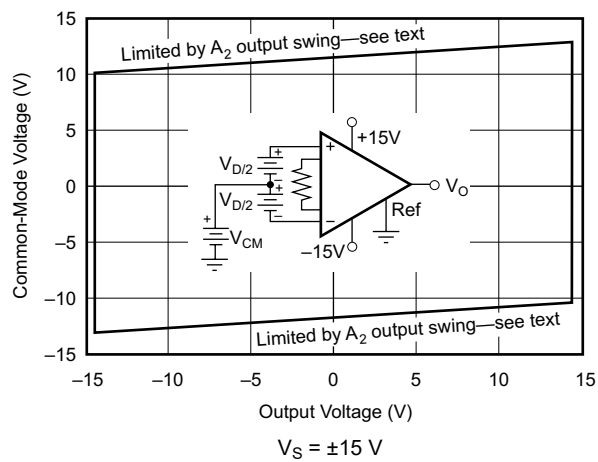
at  $T_A = 25^\circ\text{C}$ ,  $V_S = \pm 15\text{ V}$  (unless otherwise noted)

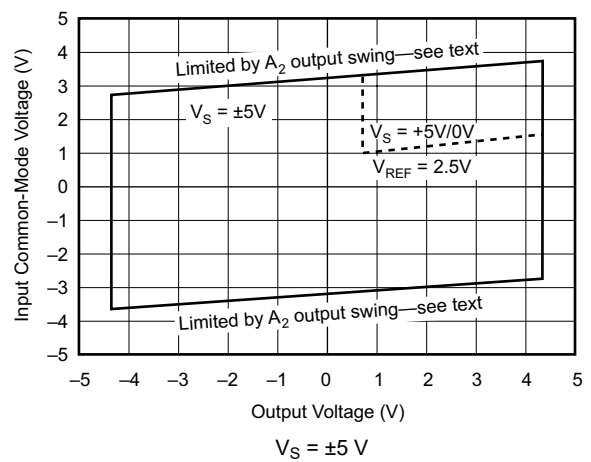

图 6-7. Input-Referred Noise vs Frequency



图 6-8. Settling Time vs Gain

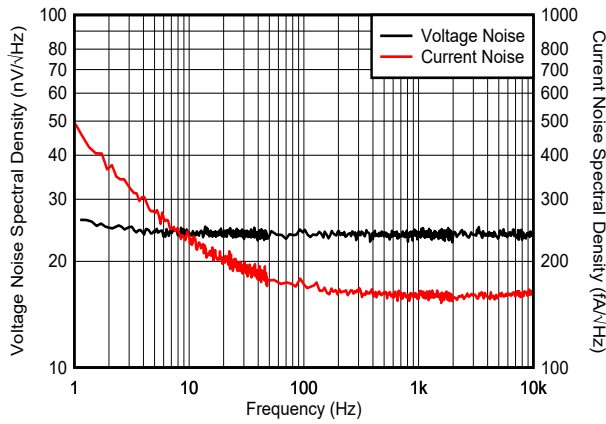

图 6-9. Input-Referred Offset Voltage WarmUp

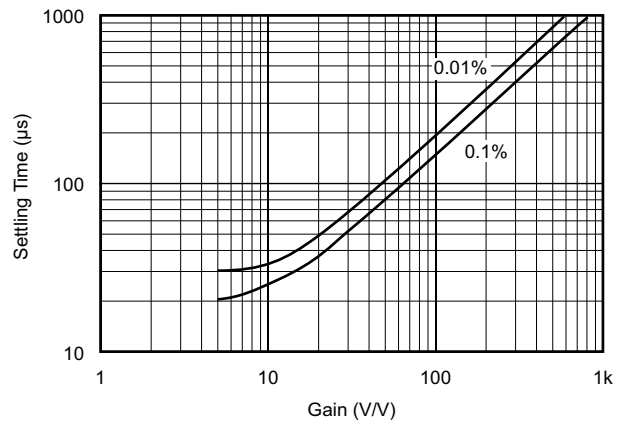

图 6-10. Quiescent Current vs Temperature

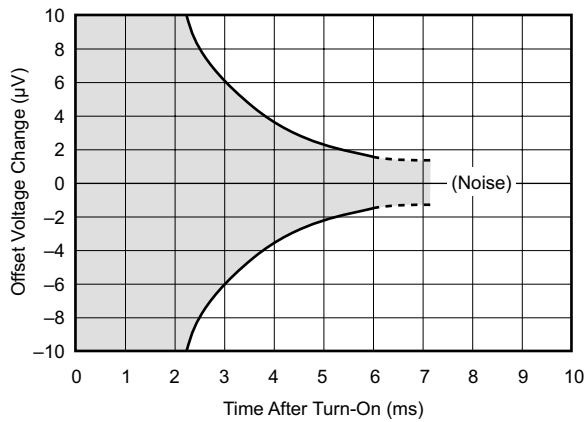

图 6-11. Slew Rate vs Temperature

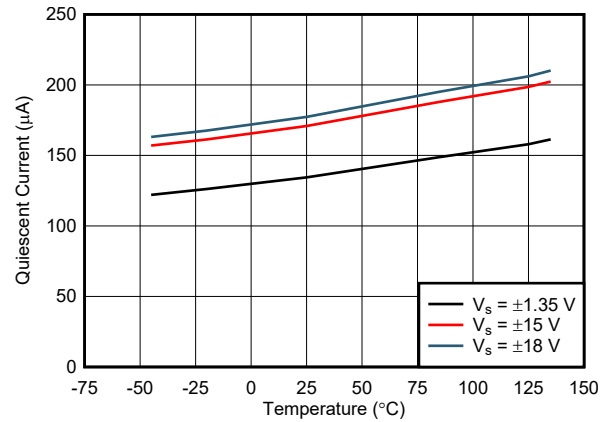

图 6-12. Total Harmonic Distortion + Noise vs Frequency

### 6.7 Typical Characteristics (continued)

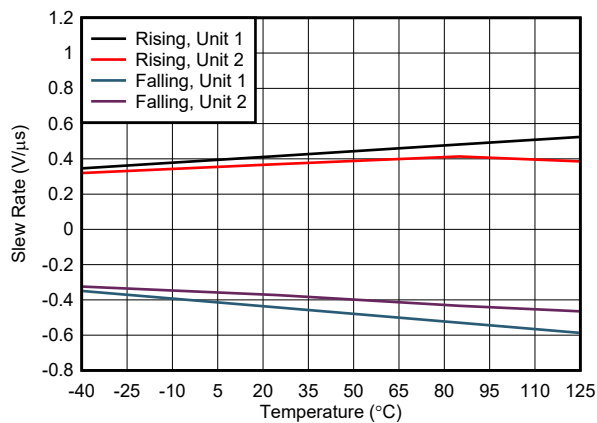
at  $T_A = 25^\circ\text{C}$ ,  $V_S = \pm 15\text{ V}$  (unless otherwise noted)

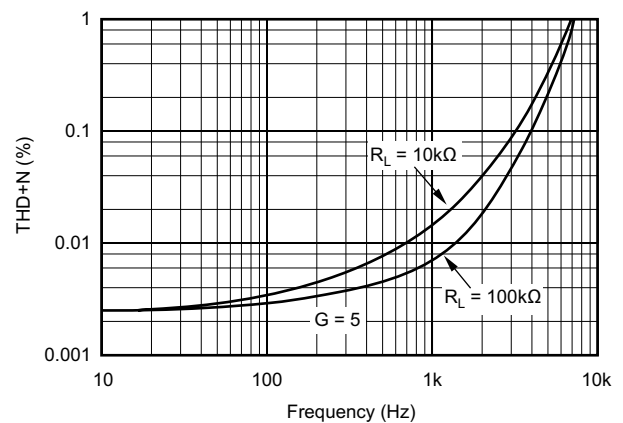
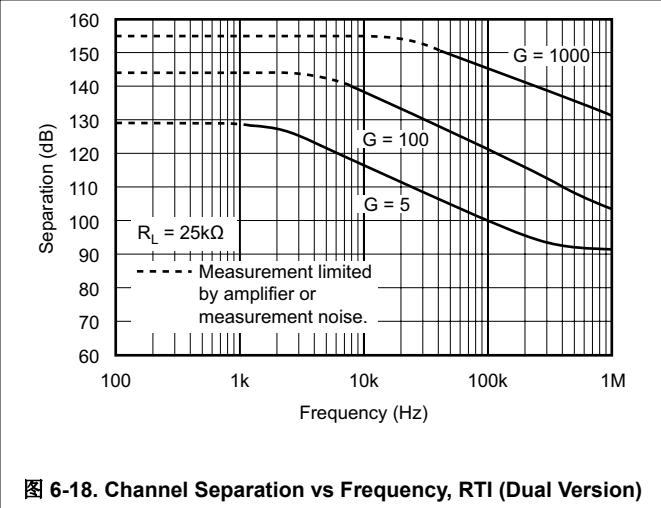
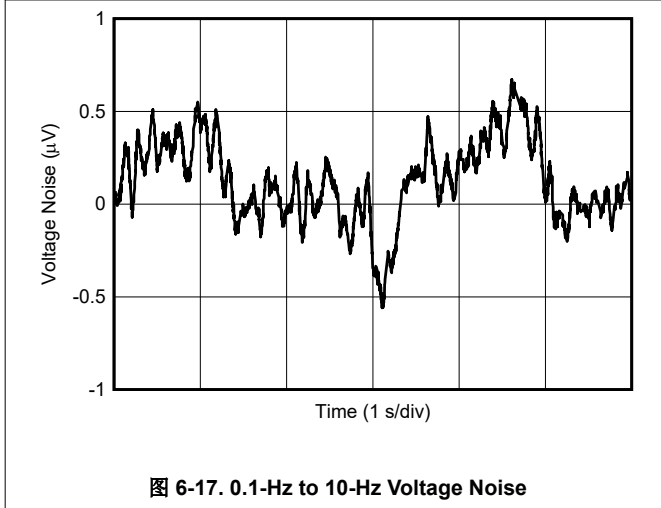
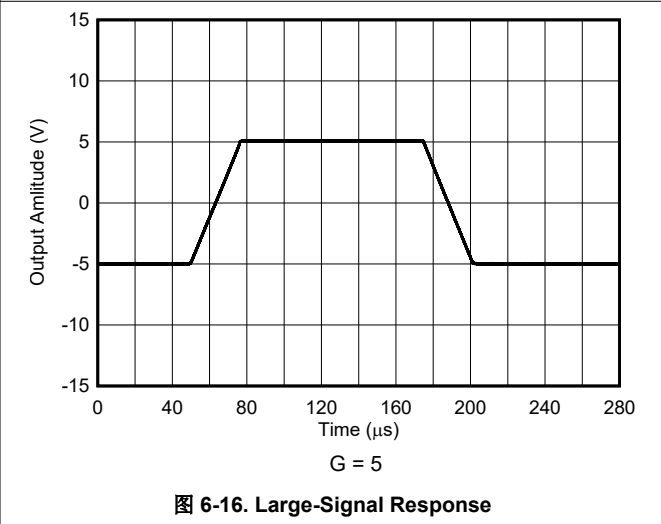
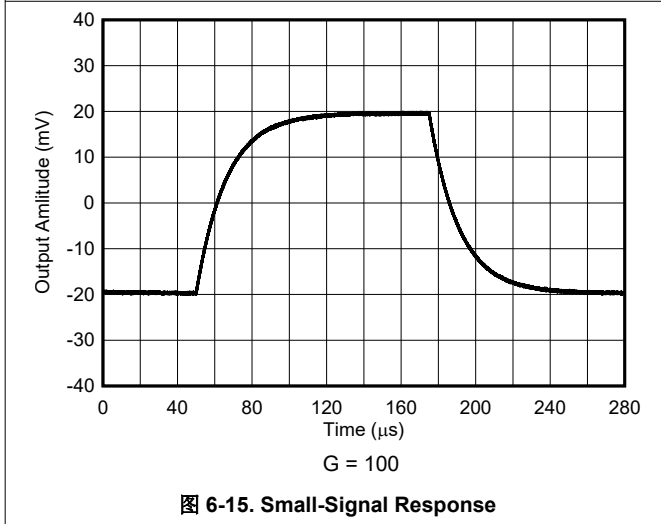
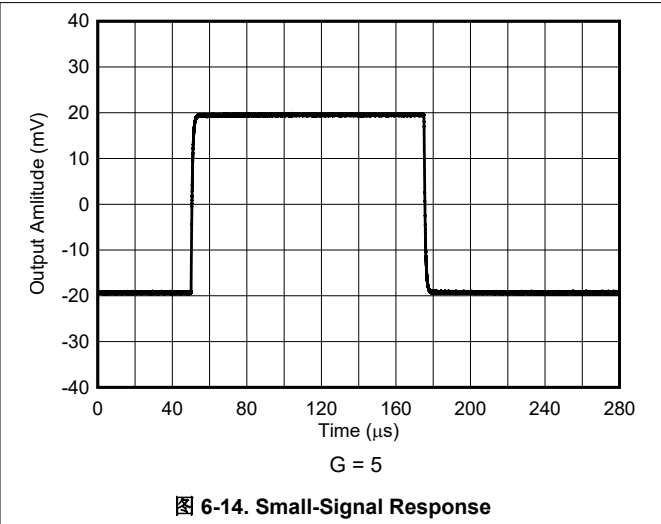
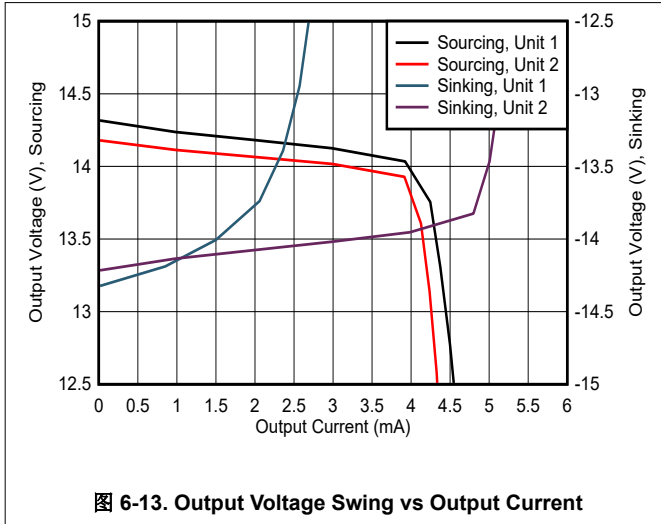

## 7 Detailed Description

### 7.1 Overview

The INAx126 use only two, rather than three, operational amplifiers, providing savings in power consumption. In addition, the input resistance is high and balanced, thus permitting the signal source to have an unbalanced output impedance.

A minimum circuit gain of 5 permits an adequate dc common-mode input range, as well as sufficient bandwidth for most applications.

### 7.2 Functional Block Diagram

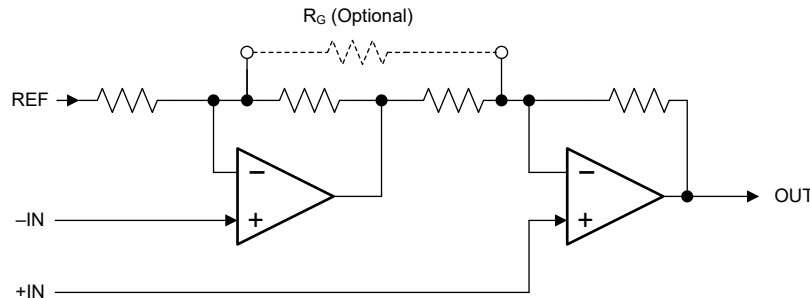

### 7.3 Feature Description

The INAx126 are low-power, general-purpose instrumentation amplifiers offering excellent accuracy. The versatile two-operational-amplifier design and small size make the amplifiers an excellent choice for a wide range of applications. The two-op-amp topology reduces power consumption. A single external resistor sets any gain from 5 to 10,000. These devices operate with power supplies as low as  $\pm 1.35$  V, and a quiescent current of 200  $\mu$ A maximum.

### 7.4 Device Functional Modes

#### 7.4.1 Single-Supply Operation

The INAx126 can be used on single power supplies from 2.7 V to 36 V. Use the output REF pin to level shift the internal output voltage into a linear operating condition. Ideally, connect the REF pin to a potential that is midsupply to avoid saturating the output of the amplifiers. See [§ 8.1](#) for information on how to adequately drive the reference pin.

## 8 Application and Implementation

### 备注

以下应用部分中的信息不属于 TI 器件规格的范围，TI 不担保其准确性和完整性。TI 的客户应负责确定器件是否适用于其应用。客户应验证并测试其设计，以确保系统功能。

### 8.1 Application Information

The INAx126 measures small differential voltage with high common-mode voltage developed between the noninverting and inverting input. The high input impedance make the INAx126 an excellent choice for a wide range of applications. The INAx126 can adjust the functionality of the output signals by setting the reference pin, giving additional flexibility that is practical for multiple configurations.

### 8.2 Typical Application

图 8-1 shows the basic connections required for operation of the INA126. Applications with noisy or high impedance power supplies may require decoupling capacitors close to the device pins as shown.

The output is referred to the output reference (Ref) pin, which is normally grounded. This connection must be low-impedance to maintain good common-mode rejection. A resistance of 8 Ω in series with the Ref pin causes a typical device to degrade to approximately 80-dB CMR.

图 8-4 depicts a desired differential signal from a sensor at 1 kHz and 5 mV<sub>PP</sub> superimposed on top of a 1-V<sub>PP</sub>, 60-Hz common-mode signal (the 1-kHz signal can not be resolved in this scope trace). The FFT trace in 图 8-5 shows the two signals. 图 8-6 shows the clearly recovered differential signal at the output of the INA126 operating at a gain of 250. The FFT of 图 8-7 shows the 60-Hz common-mode is no longer visible.

The dual version INA2126 has feedback-sense connections, Sense<sub>A</sub> and Sense<sub>B</sub>, that must be connected to the respective output pins for proper operation. The sense connection can sense the output voltage directly at the load for best accuracy.



图 8-1. Basic Connections

## 8.2.1 Design Requirements

For the traces shown in 图 8-2 and 图 8-3:

- Common-mode rejection of at least 80 dB
- Gain of 250

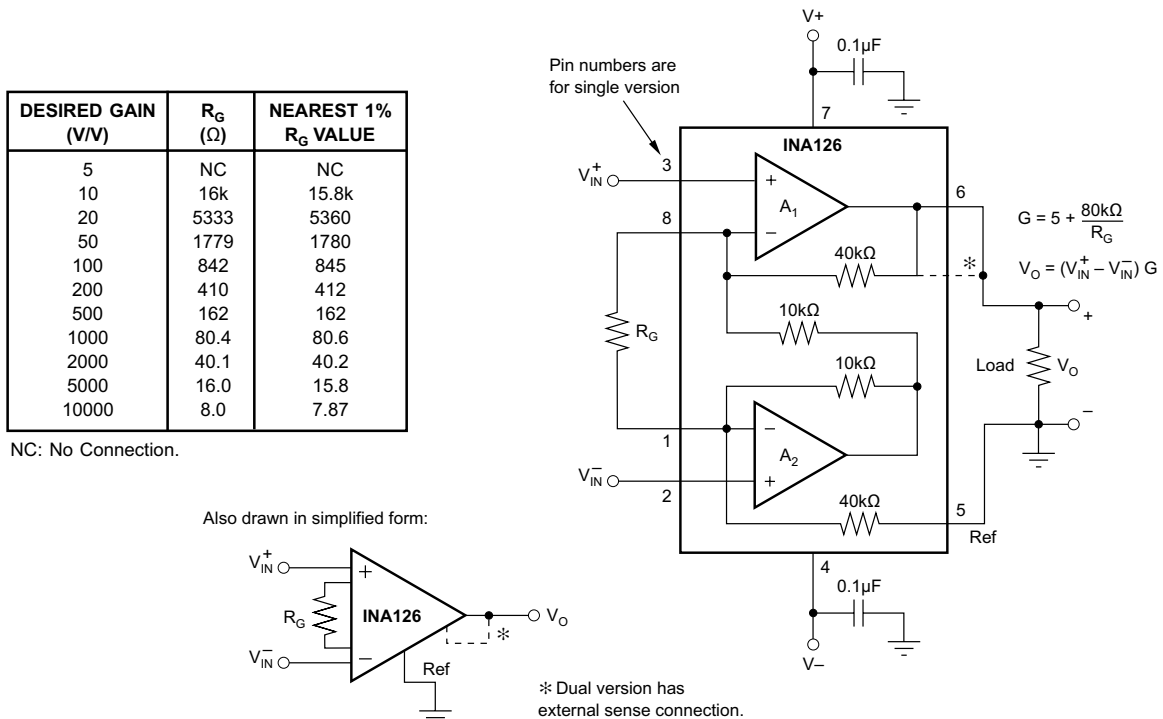
## 8.2.2 Detailed Design Procedure

### 8.2.2.1 Setting the Gain

Gain is set by connecting an external resistor,  $R_G$ :

$$g = 5 + 80 \text{ k}\Omega / R_G \quad (1)$$

Commonly used gains and  $R_G$  resistor values are shown in 图 8-1.

The 80-k $\Omega$  term in 方程式 1 comes from the internal metal-film resistors, which are laser-trimmed to accurate absolute values. The accuracy and temperature coefficient of these resistors are included in the gain accuracy and drift specifications.

The stability and temperature drift of the external gain setting resistor,  $R_G$ , also affects gain. The  $R_G$  contribution to gain accuracy and drift can be directly inferred from 方程式 1. Low resistor values required for high gain can make wiring resistance important. Sockets add to the wiring resistance, which contributes additional gain error in gains of approximately 100 or greater.

### 8.2.2.2 Offset Trimming

The INAx126 family features low offset voltage and offset voltage drift. Most applications require no external offset adjustment. 图 8-2 shows an optional circuit for trimming the output offset voltage. The voltage applied to the Ref pin is added to the output signal. An operational amplifier buffer provides low impedance at the Ref pin to preserve good common-mode rejection.



图 8-2. Optional Trimming of Output Offset Voltage

### 8.2.2.3 Input Bias Current Return

The input impedance of the INAx126 is extremely high at approximately  $10^9 \Omega$ . However, a path must be provided for the input bias current of both inputs. This input bias current is typically  $-10 \text{ nA}$  (current flows out of the input pins). High input impedance means that this input bias current changes very little with varying input voltage.

Input circuitry must provide a path for this input bias current for proper operation. 图 8-3 shows various provisions for an input bias current path. Without a bias current path, the inputs float to a potential that exceeds the common-mode range, and the input amplifiers will saturate.

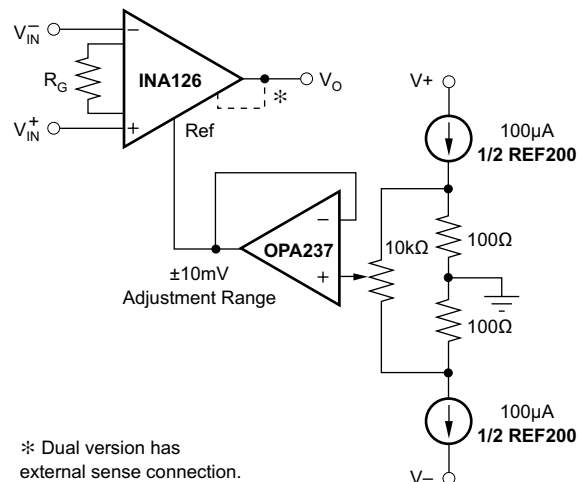
If the differential source resistance is low, the bias current return path can be connected to one input (see the thermocouple example in 图 8-3). With higher source impedance, using two equal resistors provides a balanced input with the advantages of lower input offset voltage due to bias current and better high-frequency common-mode rejection.



图 8-3. Providing an Input Common-Mode Current Path

### 8.2.2.4 Input Common-Mode Range

The input common-mode range of the INAx126 is shown in 节 6.7. The common-mode range is limited on the negative side by the output voltage swing of  $A_2$ , an internal circuit node that cannot be measured on an external pin. The output voltage of  $A_2$  can be expressed as shown in 方程式 2:

$$V_{O2} = 1.25 V^-_{IN} - (V^+_{IN} - V^-_{IN}) (10 \text{ k}\Omega / R_G) \quad (2)$$

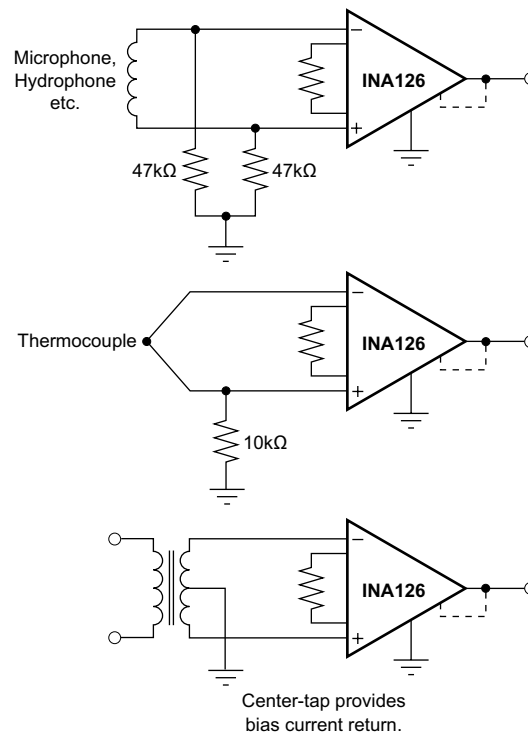
where

- Voltages referred to Ref, pin 5

The internal op amp  $A_2$  is identical to  $A_1$ , with an output swing typically limited to 0.7 V from the supply rails. When the input common-mode range is exceeded ( $A_2$  output is saturated),  $A_1$  can still be in linear operation and respond to changes in the noninverting input voltage. The output voltage, however, will be invalid.

### 8.2.2.5 Input Protection

The inputs are protected with internal diodes connected to the power-supply rails. These diodes clamp the applied signal to prevent the signal from exceeding the power supplies by more than approximately 0.7 V. If the signal-source voltage can exceed the power supplies, the source current should be limited to less than 10 mA. This limiting can generally be done with a series resistor. Some signal sources are inherently current-limited, and do not require limiting resistors.

### 8.2.2.6 Channel Crosstalk—Dual Version

The two channels of the INA2126 are completely independent, including all bias circuitry. At dc and low frequency, there is virtually no signal coupling between channels. Crosstalk increases with frequency and depends on circuit gain, source impedance, and signal characteristics.

As source impedance increases, careful circuit layout can help achieve lowest channel crosstalk. Most crosstalk is produced by capacitive coupling of signals from one channel to the input section of the other channel. To minimize coupling, separate the input traces as far as practical from any signals associated with the opposite channel. A grounded guard trace surrounding the inputs helps reduce stray coupling between channels. Carefully balance the stray capacitance of each input to ground, and run the differential inputs of each channel parallel to each other, or directly adjacent on top and bottom side of a circuit board. Stray coupling then tends to produce a common-mode signal that is rejected by the IA input.

### 8.2.3 Application Curves



图 8-4. Common-mode Signal at INA126 Input



图 8-5. FFT of Signal in Previous Figure Shows Both the 60-Hz Common-mode Along With 5-kHz Differential Signal

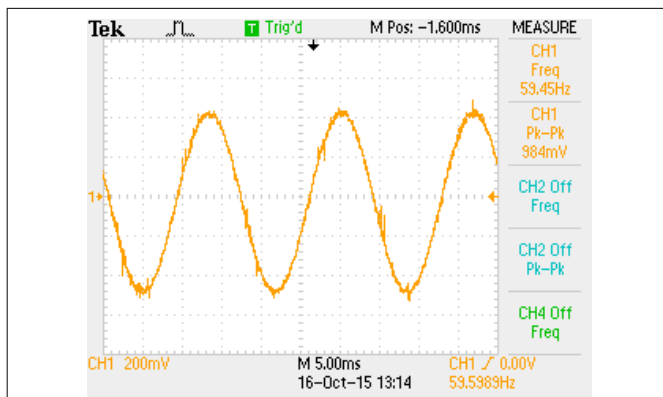

图 8-6. Recovered Differential Signal at the Output of the INA126 With a Gain of 250

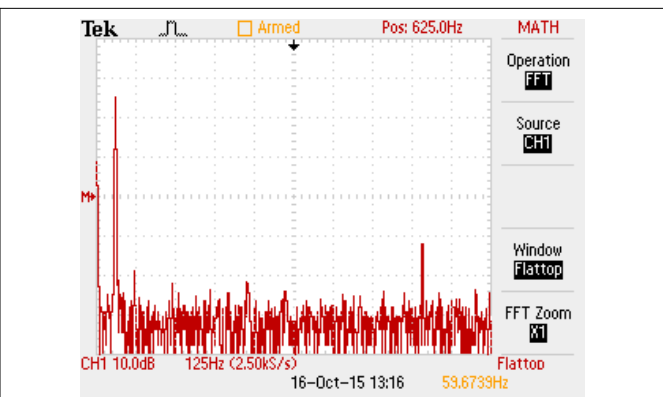

图 8-7. FFT of the INA126 Output Shows that the 60-Hz Common-mode Signal is Rejected

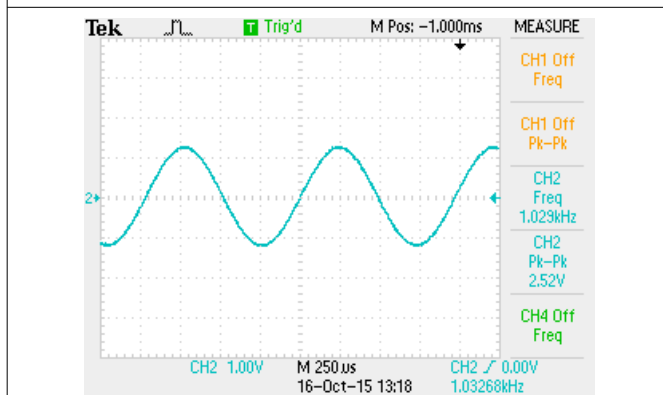

## 10 Layout

### 10.1 Layout Guidelines

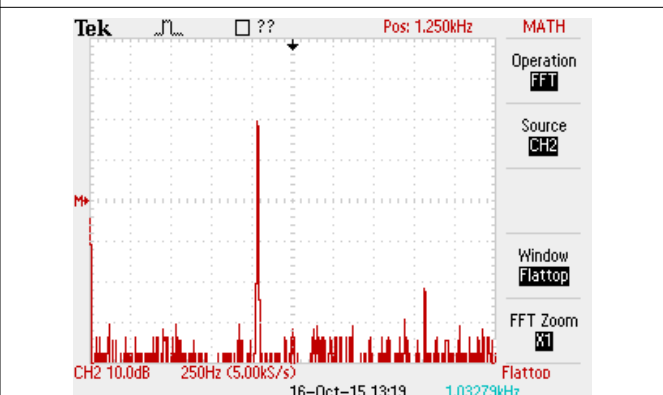
Attention to good layout practices is always recommended. For best operational performance of the device, use good printed circuit board (PCB) layout practices, including:

- Make sure that both input paths are well-matched for source impedance and capacitance to avoid converting common-mode signals into differential signals. In addition, parasitic capacitance at the gain-setting pins can also affect CMRR over frequency. For example, in applications that implement gain switching using switches or PhotoMOS<sup>®</sup> relays to change the value of  $R_G$ , select the component so that the switch capacitance is as small as possible.
  - Connect low-ESR, 0.1- $\mu$ F ceramic bypass capacitors between each supply pin and ground, placed as close to the device as possible. A single bypass capacitor from  $V+$  to ground is applicable for single-supply applications.
- Separate grounding for analog and digital portions of the circuitry is one of the simplest and most effective methods of noise suppression. One or more layers on multilayer PCBs are usually devoted to ground planes. A ground plane helps distribute heat and reduces EMI noise pickup. Make sure to physically separate digital and analog grounds, paying attention to the flow of the ground current. For more detailed information, see [PCB Design Guidelines For Reduced EMI](#).
- In order to reduce parasitic coupling, run the input traces as far away from the supply or output traces as possible. If these traces cannot be kept separate, crossing the sensitive trace perpendicular is much better than in parallel with the noisy trace.
- Place the external components as close to the device as possible. As illustrated in [图 10-1](#), keep  $R_G$  close to the pins to minimize parasitic capacitance.
- Keep the traces as short as possible

## 10.2 Layout Example



图 10-1. INA126 Layout Example



图 10-2. INA2126 Layout Example

## 11 Device and Documentation Support

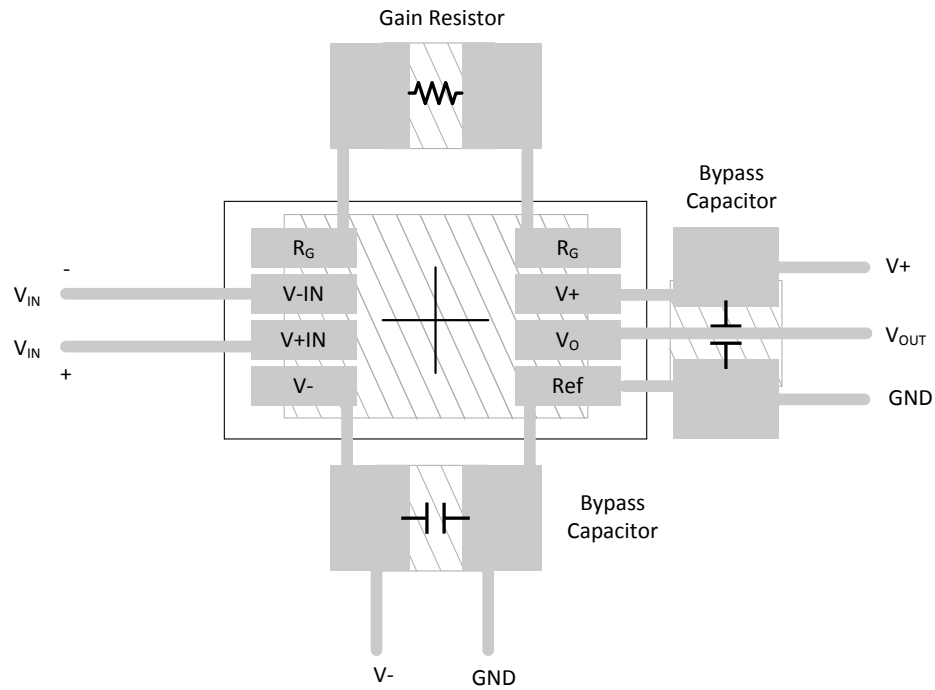
### 11.1 Device Support

#### 11.1.1 Development Support

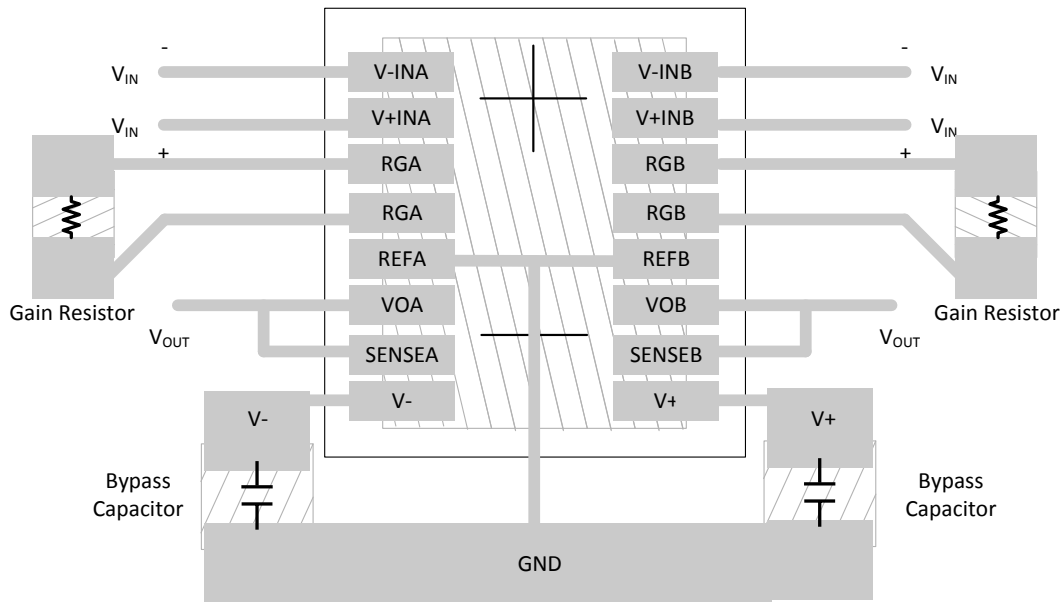
##### 11.1.1.1 PSpice® for TI

PSpice® for TI is a design and simulation environment that helps evaluate performance of analog circuits. Create subsystem designs and prototype solutions before committing to layout and fabrication, reducing development cost and time to market.

### 11.2 接收文档更新通知

要接收文档更新通知，请导航至 [ti.com](http://ti.com) 上的器件产品文件夹。点击 [订阅更新](#) 进行注册，即可每周接收产品信息更改摘要。有关更改的详细信息，请查看任何已修订文档中包含的修订历史记录。

### 11.3 支持资源

TI E2E™ 支持论坛是工程师的重要参考资料，可直接从专家获得快速、经过验证的解答和设计帮助。搜索现有解答或提出自己的问题可获得所需的快速设计帮助。

链接的内容由各个贡献者“按原样”提供。这些内容并不构成 TI 技术规范，并且不一定反映 TI 的观点；请参阅 TI 的《使用条款》。

### 11.4 Trademarks

TI E2E™ is a trademark of Texas Instruments.

PhotoMOS® is a registered trademark of Panasonic Corporation.

PSpice® is a registered trademark of Cadence Design Systems, Inc.

所有商标均为其各自所有者的财产。

### 11.5 Electrostatic Discharge Caution



This integrated circuit can be damaged by ESD. Texas Instruments recommends that all integrated circuits be handled with appropriate precautions. Failure to observe proper handling and installation procedures can cause damage.

ESD damage can range from subtle performance degradation to complete device failure. Precision integrated circuits may be more susceptible to damage because very small parametric changes could cause the device not to meet its published specifications.

### 11.6 术语表

TI 术语表 本术语表列出并解释了术语、首字母缩略词和定义。

## 12 Mechanical, Packaging, and Orderable Information

The following pages include mechanical, packaging, and orderable information. This information is the most current data available for the designated devices. This data is subject to change without notice and revision of this document. For browser-based versions of this data sheet, refer to the left-hand navigation.

## 重要声明和免责声明

TI“按原样”提供技术和可靠性数据（包括数据表）、设计资源（包括参考设计）、应用或其他设计建议、网络工具、安全信息和其他资源，不保证没有瑕疵且不做任何明示或暗示的担保，包括但不限于对适销性、某特定用途方面的适用性或不侵犯任何第三方知识产权的暗示担保。

这些资源可供使用 TI 产品进行设计的熟练开发人员使用。您将自行承担以下全部责任：(1) 针对您的应用选择合适的 TI 产品，(2) 设计、验证并测试您的应用，(3) 确保您的应用满足相应标准以及任何其他功能安全、信息安全、监管或其他要求。

这些资源如有变更，恕不另行通知。TI 授权您仅可将这些资源用于研发本资源所述的 TI 产品的应用。严禁对这些资源进行其他复制或展示。您无权使用任何其他 TI 知识产权或任何第三方知识产权。您应全额赔偿因在这些资源的使用中对 TI 及其代表造成的任何索赔、损害、成本、损失和债务，TI 对此概不负责。

TI 提供的产品受 [TI 的销售条款](#) 或 [ti.com](#) 上其他适用条款/TI 产品随附的其他适用条款的约束。TI 提供这些资源并不会扩展或以其他方式更改 TI 针对 TI 产品发布的适用的担保或担保免责声明。

TI 反对并拒绝您可能提出的任何其他或不同的条款。

邮寄地址：Texas Instruments, Post Office Box 655303, Dallas, Texas 75265

Copyright © 2022，德州仪器 (TI) 公司