

模拟输出电流分流和电压 即时功率监控器

 查询样品: **INA223**

特性

- 宽共模范围: **0V 至 26V**
- **$\pm 100\mu\text{V}$** 偏移 (最大, 增益 = **300 V/V**)
- 准确度
 - **$\pm 0.25\%$** 分流电压增益错误 (最大值)
 - **$\pm 0.15\%$** 总线电压增益错误 (最大值)
 - **1.25%** 功率错误 (最大值)
 - **$0.3\mu\text{V}/^\circ\text{C}$** 偏移漂移 (最大值)
 - **50 ppm/ $^\circ\text{C}$** 增益漂移 (最大值)
- 可编辑增益
 - 电流分流电压增益: **20, 128, 300**
 - 总线电压衰减: **1/10, 1/5, 2/5**
- 监控/测量/报告:
 - 即时功率
 - 总线电压
 - 负载电流间的关系
- 瞬态电流: **250 μA** (最大值)
- 关断电流: **1 μA** (最大值)

应用范围

- 笔记本电脑
- 手机
- 电信设备
- 电源管理

说明

INA223 是一款电压输出器件, 通过感测 0V 至 26V 的共模电压上分流的压降, 此器件监控电流、总线电压、和电源线的功率。共模电压范围与电源电压无关。零漂移架构的低偏移在整个分流中使得电流感测的最大压降低至 10mV 的量程。

INA223 包括一个用于调整此器件配置设置的两线制接口。此接口用于控制指向器件输出的信号 (电流分流电压、总线电压、或者功率)。多个增益和衰减设置可通过两线制进行设定以实现应用专用配置。可编辑增益特性也使得此器件可在更宽泛的动态电流负载范围内运行而无需切换到使用的感测元件。

提供了一个关断特性来禁用此器件并高效地从并联电阻器和电源电压上断开, 从而减少了对电池的消耗。

INA223 由单一 +2.7V 至 +5.5V 电源供电运行, 消耗的最大电源电流为 250 μA 。此器件额定扩展温度范围介于 -40°C 至 $+105^\circ\text{C}$ 之间并采用小外形尺寸无引线 (SON)-10 封装。

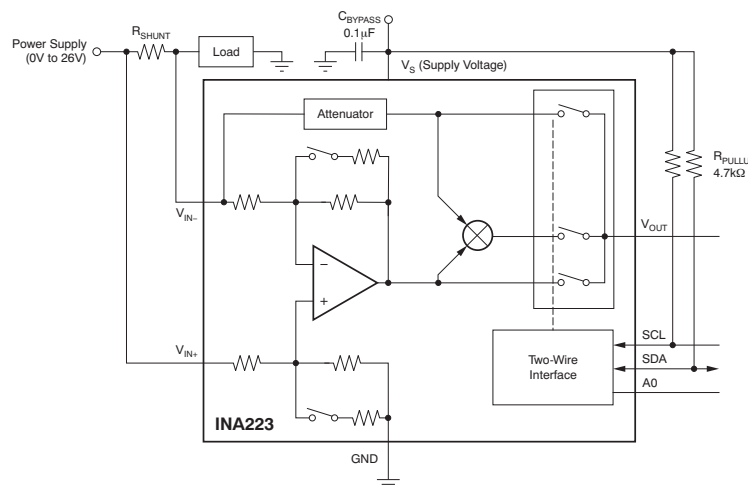

Please be aware that an important notice concerning availability, standard warranty, and use in critical applications of Texas Instruments semiconductor products and disclaimers thereto appears at the end of this data sheet.

TransZorb is a trademark of General Instruments, Inc.

All other trademarks are the property of their respective owners.



This integrated circuit can be damaged by ESD. Texas Instruments recommends that all integrated circuits be handled with appropriate precautions. Failure to observe proper handling and installation procedures can cause damage.

ESD damage can range from subtle performance degradation to complete device failure. Precision integrated circuits may be more susceptible to damage because very small parametric changes could cause the device not to meet its published specifications.

PACKAGE INFORMATION⁽¹⁾

PRODUCT	PACKAGE-LEAD	PACKAGE DESIGNATOR	PACKAGE MARKING
INA223	SON-10	DSK	P223

(1) For the most current package and ordering information, see the Package Option Addendum located at the end of this data sheet, or visit the device product folder at www.ti.com.

ABSOLUTE MAXIMUM RATINGS⁽¹⁾

Over operating free-air temperature range, unless otherwise noted.

		INA223	UNIT
Supply voltage		+6	V
Analog inputs, V_{IN+} , V_{IN-} ⁽²⁾	Differential (V_{IN+}) – (V_{IN-})	–26 to +26	V
	Common-mode ⁽³⁾	(GND – 0.3) to +26	V
Input current into any pin ⁽³⁾		5	mA
Operating temperature		–55 to +150	°C
Storage temperature		–65 to +150	°C
Junction temperature		+150	°C
Electrostatic discharge (ESD) ratings	Human body model (HBM)	2500	V
	Charged-device model (CDM)	1000	V
	Machine model (MM)	200	V

- (1) Stresses above these ratings may cause permanent damage. Exposure to absolute maximum conditions for extended periods may degrade device reliability. These are stress ratings only, and functional operation of the device at these or any other conditions beyond those specified is not implied.
- (2) V_{IN+} and V_{IN-} are the voltages at the +IN and –IN pins, respectively.
- (3) Input voltage at any pin may exceed the voltage shown if the current at that pin is limited to 5 mA.

ELECTRICAL CHARACTERISTICS

At $T_A = +25^\circ\text{C}$, $V_{\text{SENSE}} = (V_{\text{IN}+}) - (V_{\text{IN}-}) = 10\text{ mV}$, $V_S = 3.3\text{ V}$, and $V_{\text{IN}+} = 12\text{ V}$, unless otherwise noted.

PARAMETER		TEST CONDITIONS	INA223			UNIT
			MIN	TYP	MAX	
INPUT						
V_{CM}	Common-mode input range	$T_A = -40^\circ\text{C}$ to $+105^\circ\text{C}$	0		26	V
CMR	Common-mode rejection	$T_A = -40^\circ\text{C}$ to $+105^\circ\text{C}$, $V_{\text{IN}+} = 0\text{ V}$ to $+26\text{ V}$, $V_{\text{SENSE}} = 0\text{ mV}$, Current shunt voltage gain = 20 V/V	92	106		dB
		$T_A = -40^\circ\text{C}$ to $+105^\circ\text{C}$, $V_{\text{IN}+} = 0\text{ V}$ to $+26\text{ V}$, $V_{\text{SENSE}} = 0\text{ mV}$, Current shunt voltage gain = 128 V/V , 300V/V	100	120		dB
V_{OS}	Shunt offset voltage, RTI ⁽¹⁾	Current shunt voltage gain = 20 V/V		± 75	± 300	μV
		Current shunt voltage gain = 128 V/V		± 20	± 150	μV
		Current shunt voltage gain = 300 V/V		± 15	± 100	μV
dV_{OS}/dT	vs temperature	$T_A = -40^\circ\text{C}$ to $+105^\circ\text{C}$, current shunt voltage gain = 20 V/V		0.6	1	$\mu\text{V}/^\circ\text{C}$
		$T_A = -40^\circ\text{C}$ to $+105^\circ\text{C}$, current shunt voltage gain = 128 V/V , 300V/V		0.1	0.3	
PSR	vs power supply	$V_S = +2.7\text{ V}$ to $+5.5\text{ V}$, current shunt voltage gain = 20 V/V		± 15	± 50	$\mu\text{V/V}$
		$V_S = +2.7\text{ V}$ to $+5.5\text{ V}$, current shunt voltage gain = 128 V/V		± 5	± 25	$\mu\text{V/V}$
		$V_S = +2.7\text{ V}$ to $+5.5\text{ V}$, current shunt voltage gain = 300 V/V		± 2.5	± 15	$\mu\text{V/V}$
V_{OS}	Bus offset voltage, RTI ⁽¹⁾	Bus voltage gain = 0.1 V/V		± 2.5	± 20	mV
		Bus voltage gain = 0.2 V/V		± 2.5	± 15	mV
		Bus voltage gain = 0.4 V/V		± 1.5	± 10	mV
dV_{OS}/dT	vs temperature	$T_A = -40^\circ\text{C}$ to $+105^\circ\text{C}$, bus voltage gain = 0.1 V/V		15	40	$\mu\text{V}/^\circ\text{C}$
		$T_A = -40^\circ\text{C}$ to $+105^\circ\text{C}$, bus voltage gain = 0.2 V/V , 0.4 V/V		10	30	$\mu\text{V}/^\circ\text{C}$
PSR	vs power supply	$V_S = +2.7\text{ V}$ to $+5.5\text{ V}$		± 9	± 15	mV/V
I_B	Input bias current	Enabled, $V_{\text{IN}+}$, $V_{\text{IN}-}$	15	18	25	μA
		Disabled, $V_{\text{IN}+}$, $V_{\text{IN}-}$		1	1.5	μA
	Input impedance, differential			2.5		k Ω
OUTPUT						
G_{SV}	Current shunt voltage gain		20, 128, 300			V/V
	Current shunt voltage gain error	$T_A = -40^\circ\text{C}$ to $+105^\circ\text{C}$, $V_{\text{SENSE}} = 10\text{ mV}$ to 155 mV , current shunt voltage gain = 20 V/V		$\pm 0.05\%$	$\pm 0.25\%$	
		$T_A = -40^\circ\text{C}$ to $+105^\circ\text{C}$, $V_{\text{SENSE}} = 1.5\text{ mV}$ to 24 mV , current shunt voltage gain = 128 V/V		$\pm 0.05\%$	$\pm 0.5\%$	
		$T_A = -40^\circ\text{C}$ to $+105^\circ\text{C}$, $V_{\text{SENSE}} = 1\text{ mV}$ to 9 mV , current shunt voltage gain = 300 V/V		$\pm 0.2\%$	$\pm 1\%$	
	vs temperature	$T_A = -40^\circ\text{C}$ to $+105^\circ\text{C}$, current shunt voltage gain = 20 V/V			50	ppm/ $^\circ\text{C}$
		$T_A = -40^\circ\text{C}$ to $+105^\circ\text{C}$, current shunt voltage gain = 128 V/V			75	ppm/ $^\circ\text{C}$
		$T_A = -40^\circ\text{C}$ to $+105^\circ\text{C}$, current shunt voltage gain = 300 V/V			125	ppm/ $^\circ\text{C}$
	Nonlinearity error	$V_{\text{SENSE}} = 1\text{ mV}$ to 10 mV		$\pm 0.01\%$		
G_{BV}	Bus voltage gain		0.1, 0.2, 0.4			V/V
	Bus voltage gain error	$T_A = -40^\circ\text{C}$ to $+105^\circ\text{C}$, bus voltage gain = 0.1 V/V , $V_{\text{CM}} = 0.5\text{ V}$ to 26 V		$\pm 0.05\%$	$\pm 0.2\%$	
		$T_A = -40^\circ\text{C}$ to $+105^\circ\text{C}$, bus voltage gain = 0.2 V/V , $V_{\text{CM}} = 0.5\text{ V}$ to 12 V		$\pm 0.025\%$	$\pm 0.15\%$	
		$T_A = -40^\circ\text{C}$ to $+105^\circ\text{C}$, bus voltage gain = 0.4 V/V , $V_{\text{CM}} = 0.5\text{ V}$ to 6 V		$\pm 0.025\%$	$\pm 0.15\%$	
	vs temperature	$T_A = -40^\circ\text{C}$ to $+105^\circ\text{C}$			5	ppm/ $^\circ\text{C}$
	Nonlinearity error			$\pm 0.01\%$		

(1) RTI = referred-to-input.

ELECTRICAL CHARACTERISTICS (continued)

At $T_A = +25^\circ\text{C}$, $V_{\text{SENSE}} = (V_{\text{IN}+}) - (V_{\text{IN}-}) = 10\text{ mV}$, $V_S = 3.3\text{ V}$, and $V_{\text{IN}+} = 12\text{ V}$, unless otherwise noted.

PARAMETER	TEST CONDITIONS	INA223			UNIT
		MIN	TYP	MAX	
Power measurement error	Current shunt voltage gain = 20 V/V; bus voltage gain = 0.1 V/V, 0.2V/V, 0.4V/V		±0.35	±1.25	%FSR
	Current shunt voltage gain = 20 V/V; bus voltage gain = 0.1 V/V, 0.2V/V, 0.4V/V $T_A = -40^\circ\text{C}$ to $+105^\circ\text{C}$			±2	%FSR
	Current shunt voltage gain = 128 V/V, 300V/V; bus voltage gain = 0.1 V/V, 0.2V/V, 0.4V/V		±0.35	±1.5	%FSR
	Current shunt voltage gain = 128 V/V, 300V/V; bus voltage gain = 0.1 V/V, 0.2V/V, 0.4V/V; $T_A = -40^\circ\text{C}$ to $+105^\circ\text{C}$			±2.25	%FSR
Output impedance			4		Ω
Maximum capacitive load	No sustained oscillation		1		nF
VOLTAGE OUTPUT⁽²⁾					
Swing to VS power-supply rail	$T_A = -40^\circ\text{C}$ to $+105^\circ\text{C}$, $R_L = 10\text{ k}\Omega$ to GND		$V_S - 0.015$	$V_S - 0.035$	V
Swing to GND	$T_A = -40^\circ\text{C}$ to $+105^\circ\text{C}$, $R_L = 10\text{ k}\Omega$ to GND		$V_{\text{GND}} + 2.5$	$V_{\text{GND}} + 10$	mV
FREQUENCY RESPONSE					
GBW	Bandwidth	Gain = 300, $C_{\text{LOAD}} = 10\text{ pF}$		10	kHz
		Gain = 128, $C_{\text{LOAD}} = 10\text{ pF}$		20	kHz
		Gain = 20, $C_{\text{LOAD}} = 10\text{ pF}$		25	kHz
SR	Slew rate		0.25		V/ μs
NOISE, RTI⁽¹⁾					
Voltage noise density		0.1 Hz to 10 Hz, current shunt voltage gain = 20 V/V		235	nV/ $\sqrt{\text{Hz}}$
		0.1 Hz to 10 Hz, current shunt voltage gain = 300 V/V		54	nV/ $\sqrt{\text{Hz}}$
DIGITAL INPUTS (SDA as Input, SCL, A0)					
	Input capacitance		3		pF
V_{IH}	High-level input voltage		$0.7(V_S)$	6	V
V_{IL}	Low-level input voltage		-0.3	$0.3(V_S)$	V
	Leakage input current		0.1	1	μA
	Hysteresis		500		mV

(2) See Typical Characteristic curve, *Output Swing vs Output Current* (Figure 22).

ELECTRICAL CHARACTERISTICS (continued)

 At $T_A = +25^\circ\text{C}$, $V_{\text{SENSE}} = (V_{\text{IN}+}) - (V_{\text{IN}-}) = 10\text{ mV}$, $V_S = 3.3\text{ V}$, and $V_{\text{IN}+} = 12\text{ V}$, unless otherwise noted.

PARAMETER	TEST CONDITIONS	INA223			UNIT	
		MIN	TYP	MAX		
POWER SUPPLY						
V_S	Operating range	$T_A = -40^\circ\text{C}$ to $+105^\circ\text{C}$			V	
I_Q	Quiescent current	Enabled	200	250	μA	
		Disabled	0.1	1	μA	
	Power-on reset threshold	2			V	
TEMPERATURE						
	Specified range	-40			+105	$^\circ\text{C}$

THERMAL INFORMATION

THERMAL METRIC ⁽¹⁾		INA223	UNITS
		DSK (SON)	
		10 PINS	
θ_{JA}	Junction-to-ambient thermal resistance	47.5	$^\circ\text{C}/\text{W}$
$\theta_{J\text{Ctop}}$	Junction-to-case (top) thermal resistance	57.9	
θ_{JB}	Junction-to-board thermal resistance	21.5	
ψ_{JT}	Junction-to-top characterization parameter	0.8	
ψ_{JB}	Junction-to-board characterization parameter	21.8	
$\theta_{J\text{Cbot}}$	Junction-to-case (bottom) thermal resistance	4.6	

 (1) 有关传统和全新热度的更多信息，请参阅 *IC 封装热度量* 应用报告 (文献号：SPRA953)。

PIN CONFIGURATIONS

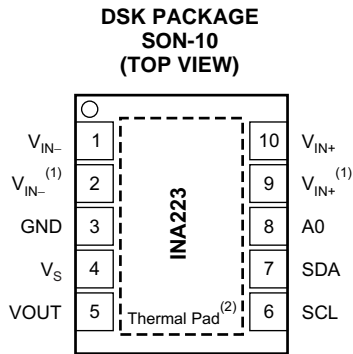

- (1) See [Application Information](#) section for a description of how to connect input pins to the shunt resistor.
- (2) Must be connected to ground.

PIN DESCRIPTIONS

PIN		ANALOG/DIGITAL INPUT/OUTPUT	DESCRIPTION
NAME	NUMBER		
A0	8	Digital input	Address pin. Connect to GND, SCL, SDA, or V _S . Table 6 shows pin settings and corresponding address.
GND	3	Analog	Ground
SCL	6	Digital input	Serial bus clock line
SDA	7	Digital I/O	Serial bus data line
V _{IN+}	9	Analog input	Connect to supply side of shunt resistor. This pin can also be connected directly to pin 10.
V _{IN+}	10	Analog input	Connect to supply side of shunt resistor
V _{IN-}	1	Analog input	Connect to load side of shunt resistor
V _{IN-}	2	Analog input	Connect to load side of shunt resistor. This pin can also be connected directly to pin 1.
V _{OUT}	5	Analog output	Output signal selected by multiplexer
V _S	4	Analog	Power supply (2.7 V to 5.5 V)

TYPICAL CHARACTERISTICS

At $T_A = +25^\circ\text{C}$, $V_S = +3.3\text{ V}$, $V_{IN+} = 12\text{ V}$ unless otherwise noted.

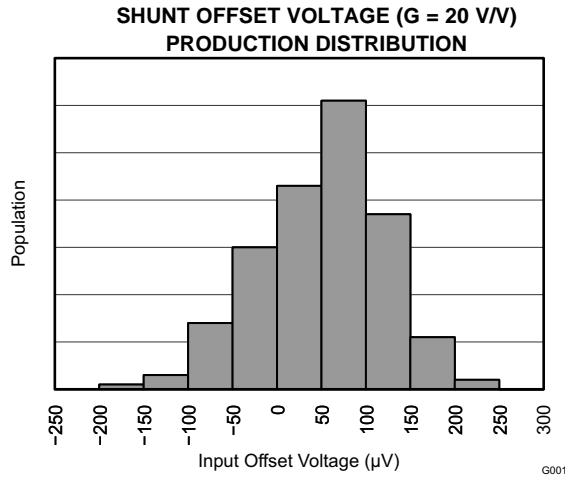

Figure 1.

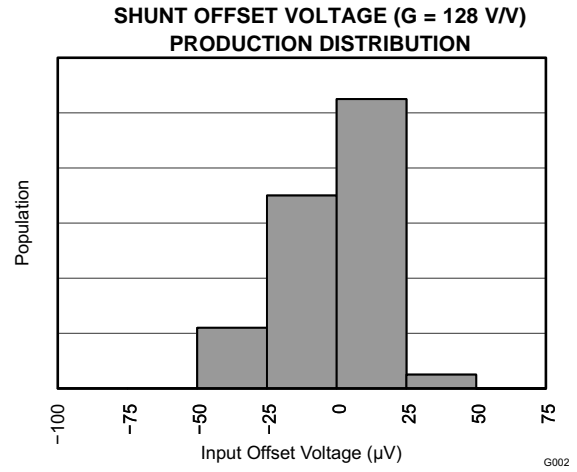

Figure 2.

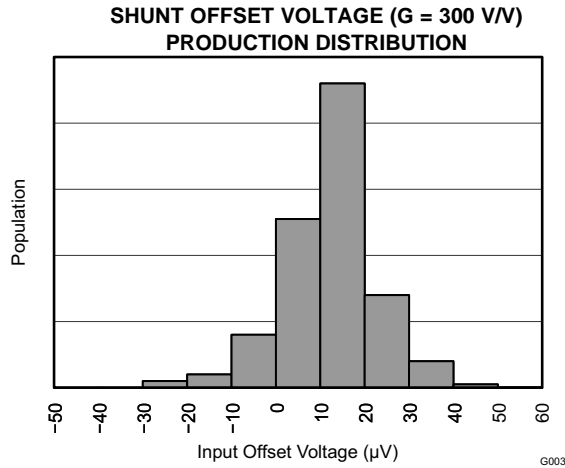

Figure 3.

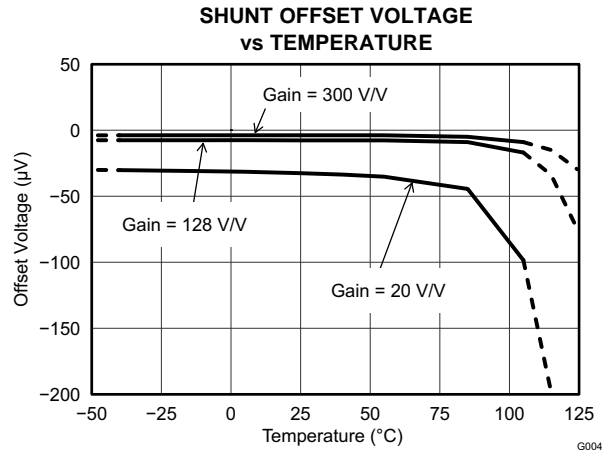

Figure 4.

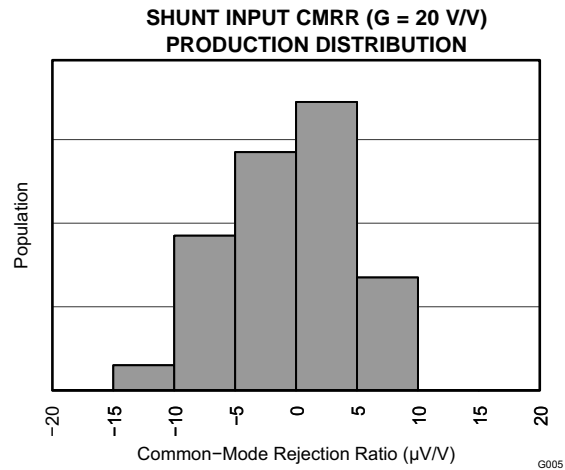

Figure 5.

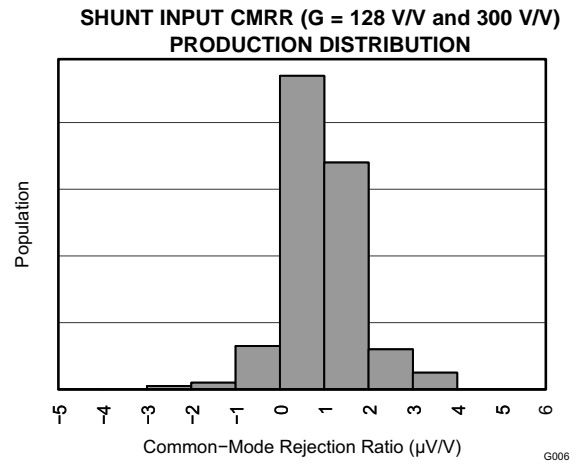

Figure 6.

TYPICAL CHARACTERISTICS (continued)

At $T_A = +25^\circ\text{C}$, $V_S = +3.3\text{ V}$, $V_{IN+} = 12\text{ V}$ unless otherwise noted.

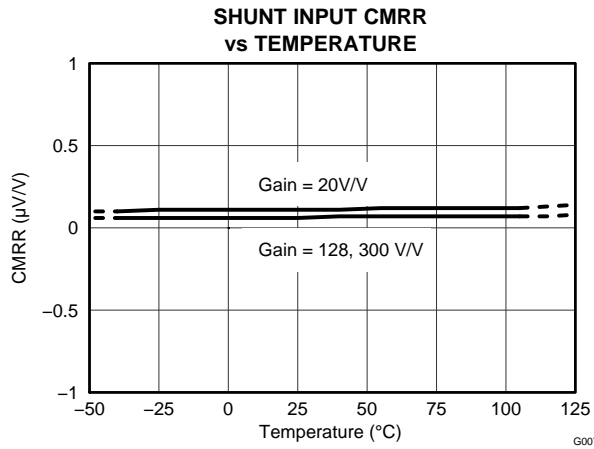

Figure 7.

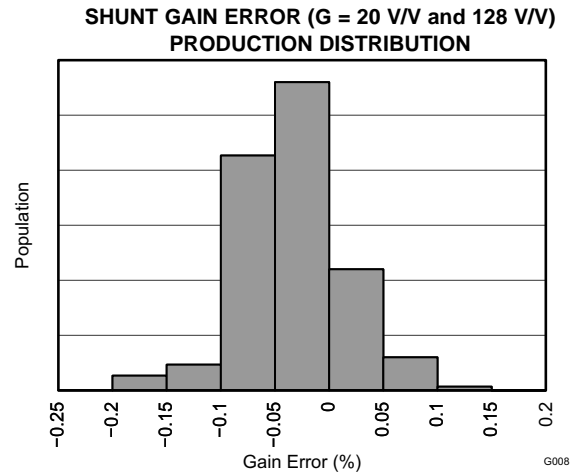

Figure 8.

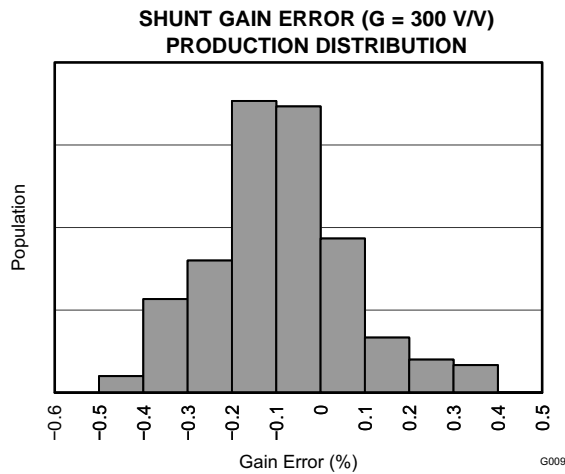

Figure 9.

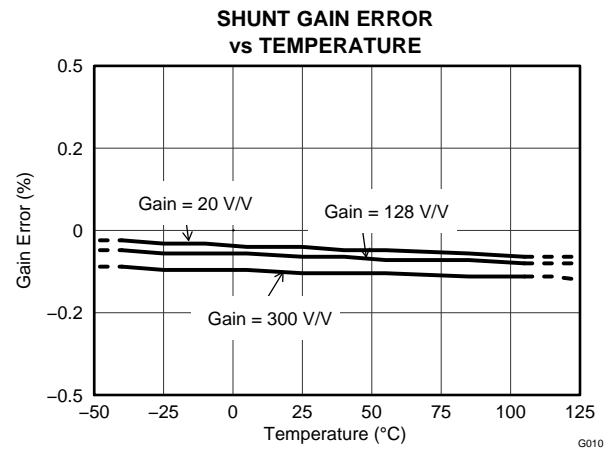

Figure 10.

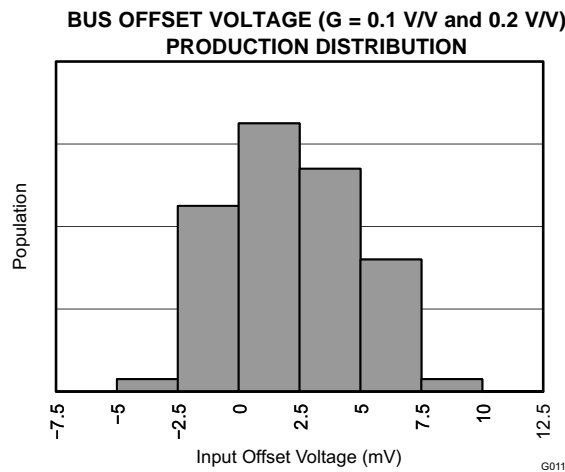

Figure 11.

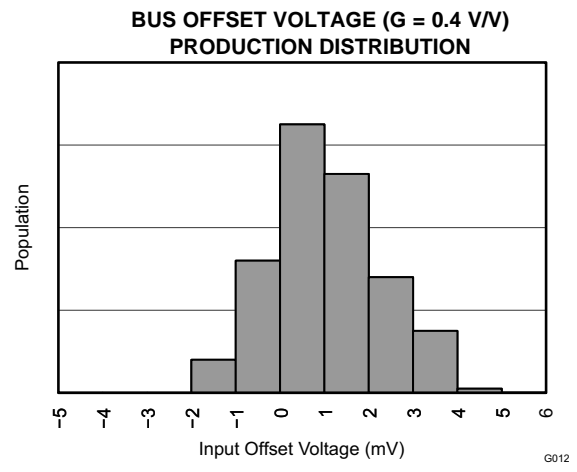

Figure 12.

TYPICAL CHARACTERISTICS (continued)

At $T_A = +25^\circ\text{C}$, $V_S = +3.3\text{ V}$, $V_{IN+} = 12\text{ V}$ unless otherwise noted.

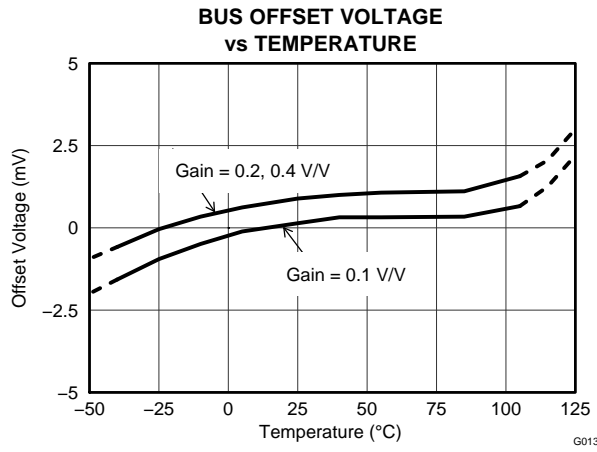

Figure 13.

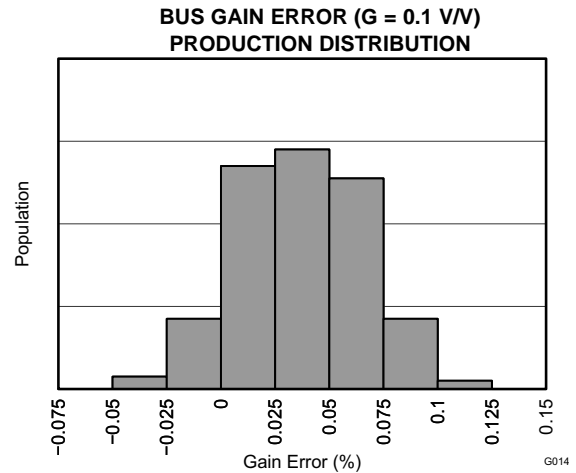

Figure 14.

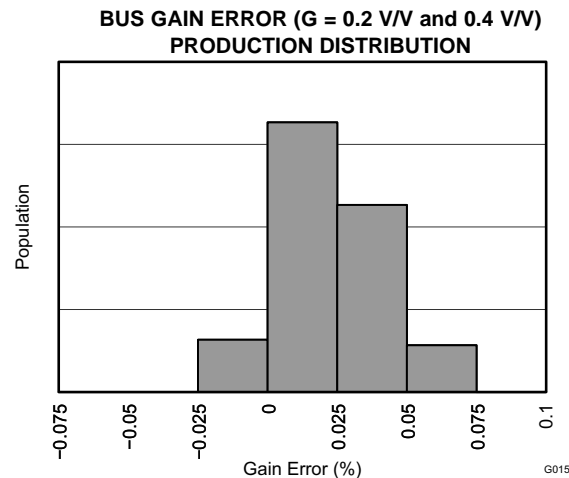

Figure 15.

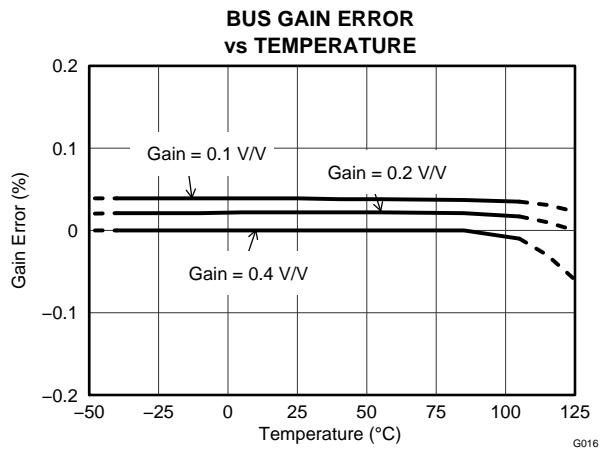

Figure 16.

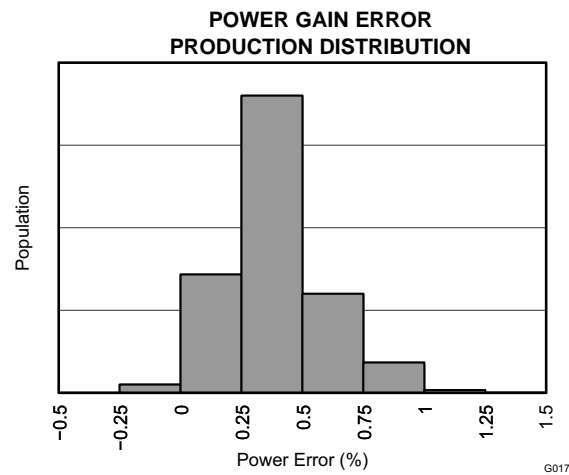

Figure 17.

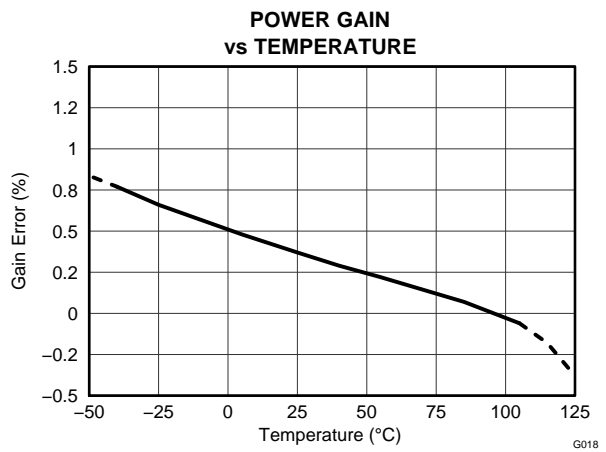

Figure 18.

TYPICAL CHARACTERISTICS (continued)

At $T_A = +25^\circ\text{C}$, $V_S = +3.3\text{ V}$, $V_{IN+} = 12\text{ V}$ unless otherwise noted.

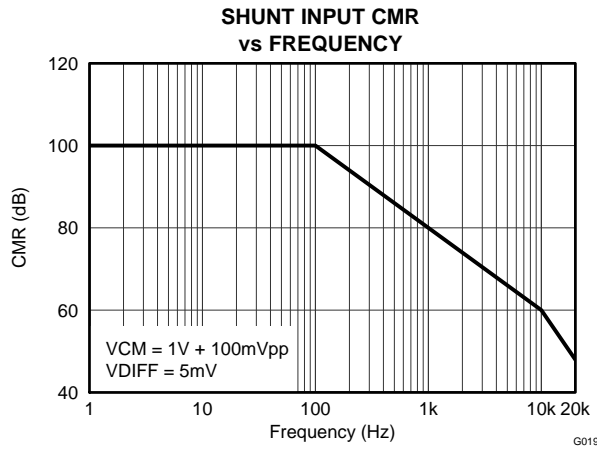

Figure 19.

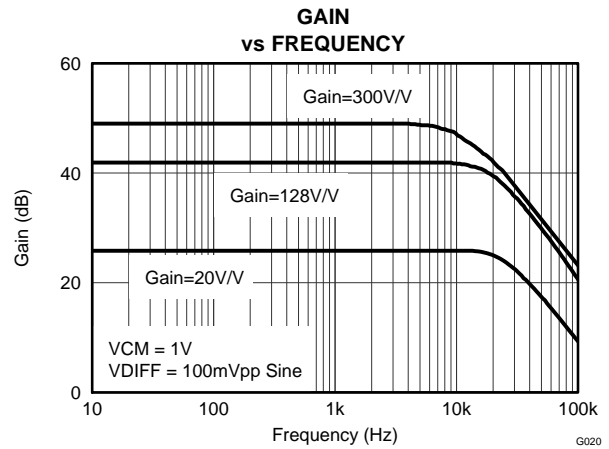

Figure 20.

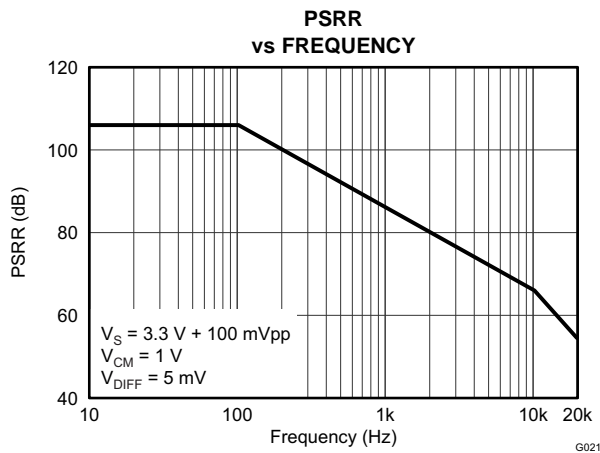

Figure 21.

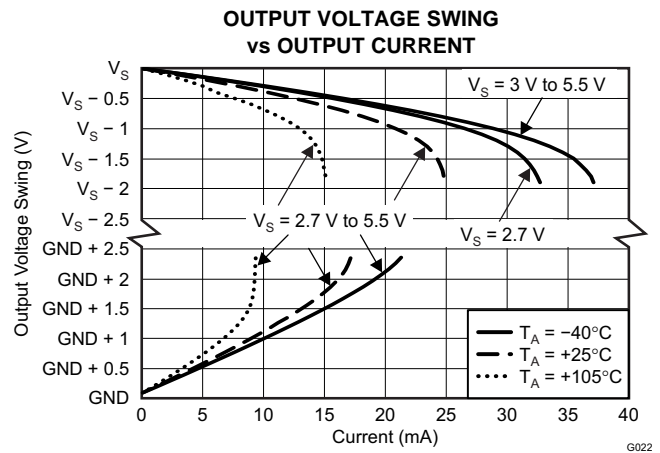

Figure 22.

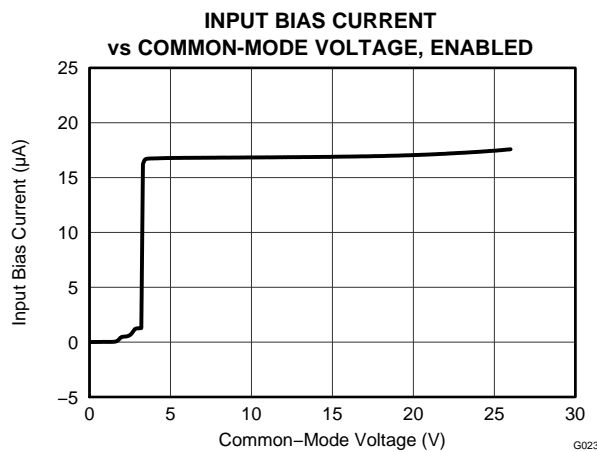

Figure 23.

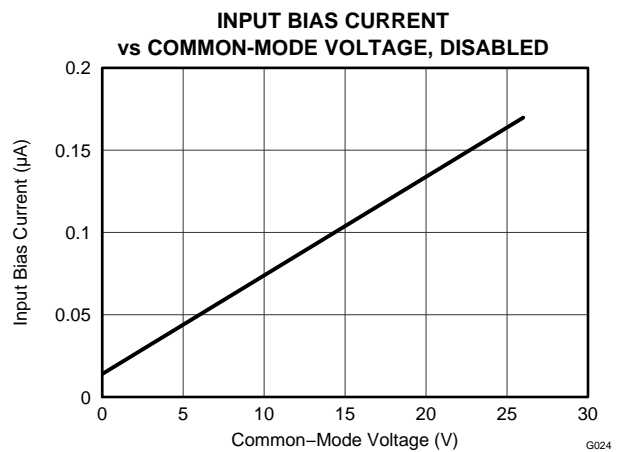
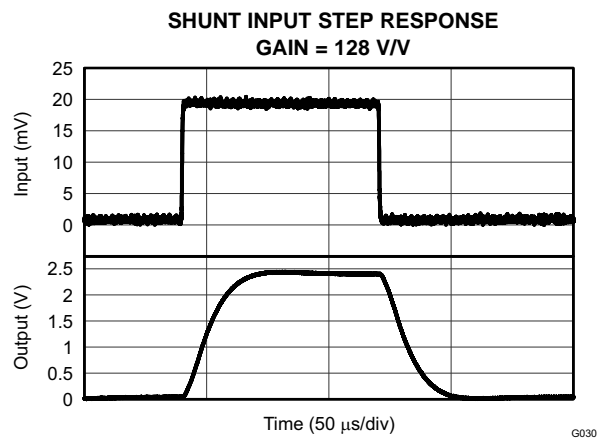
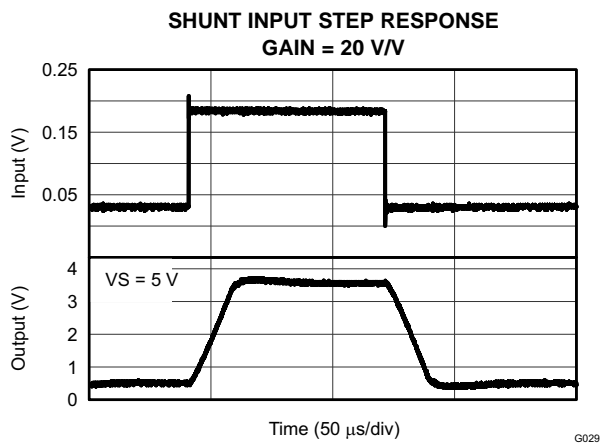
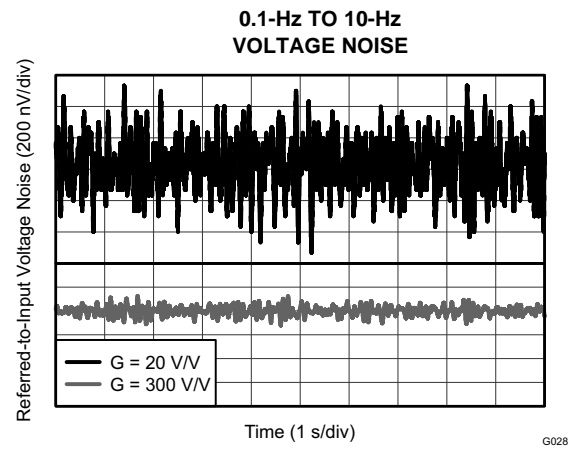
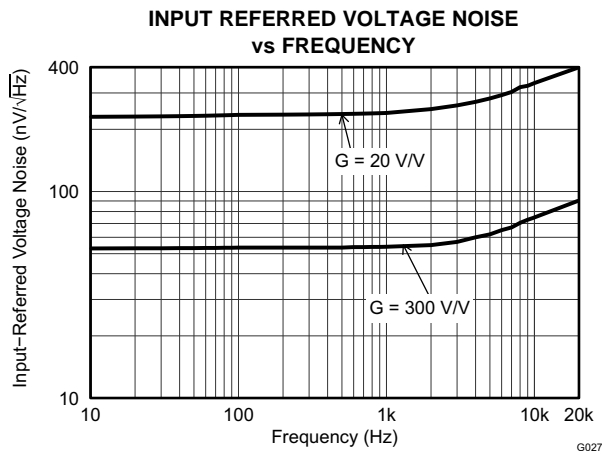
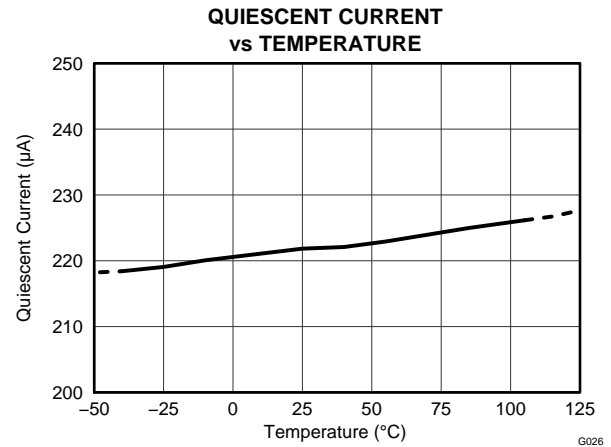
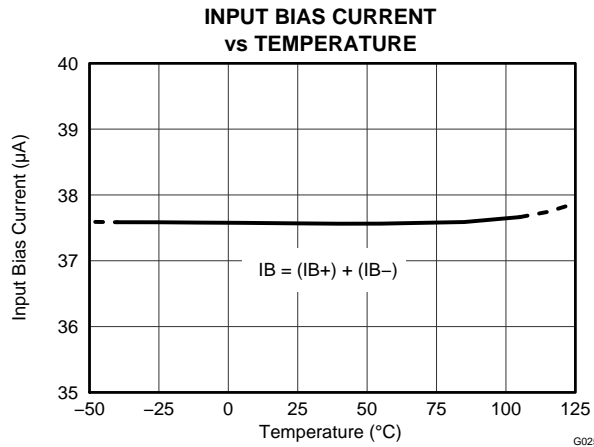

Figure 24.

TYPICAL CHARACTERISTICS (continued)

At $T_A = +25^\circ\text{C}$, $V_S = +3.3\text{ V}$, $V_{IN+} = 12\text{ V}$ unless otherwise noted.



TYPICAL CHARACTERISTICS (continued)

At $T_A = +25^\circ\text{C}$, $V_S = +3.3\text{ V}$, $V_{IN+} = 12\text{ V}$ unless otherwise noted.

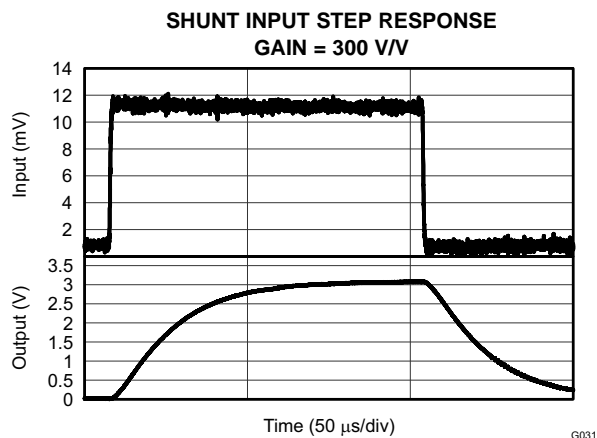

Figure 31.

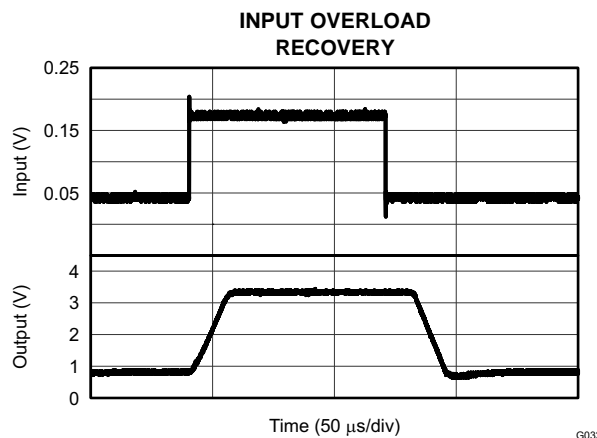

Figure 32.

APPLICATION INFORMATION

The INA223 is an analog output current shunt monitor that incorporates an analog multiplier to provide instantaneous power measurement. The INA223 features a two-wire and SMBus-compatible interface allowing the configuration settings of the device to be adjusted and changed as needed, based on the specific application requirements. The configuration options include the selection of the desired signal to be available at the output pin, switching between multiple current shunt voltage gains and bus voltage attenuation factors, as well as being able to place the device into a disabled state.

INA223 TYPICAL APPLICATION

Figure 33 shows the typical application circuit for the INA223. The input pins, V_{IN+} and V_{IN-} , should be connected as close as possible to the shunt resistor to minimize any resistance in series with the shunt resistance. A power-supply bypass capacitor is required for stability. Use a 0.1- μF ceramic capacitor for supply bypassing, placed as close as possible between the supply and ground pins.

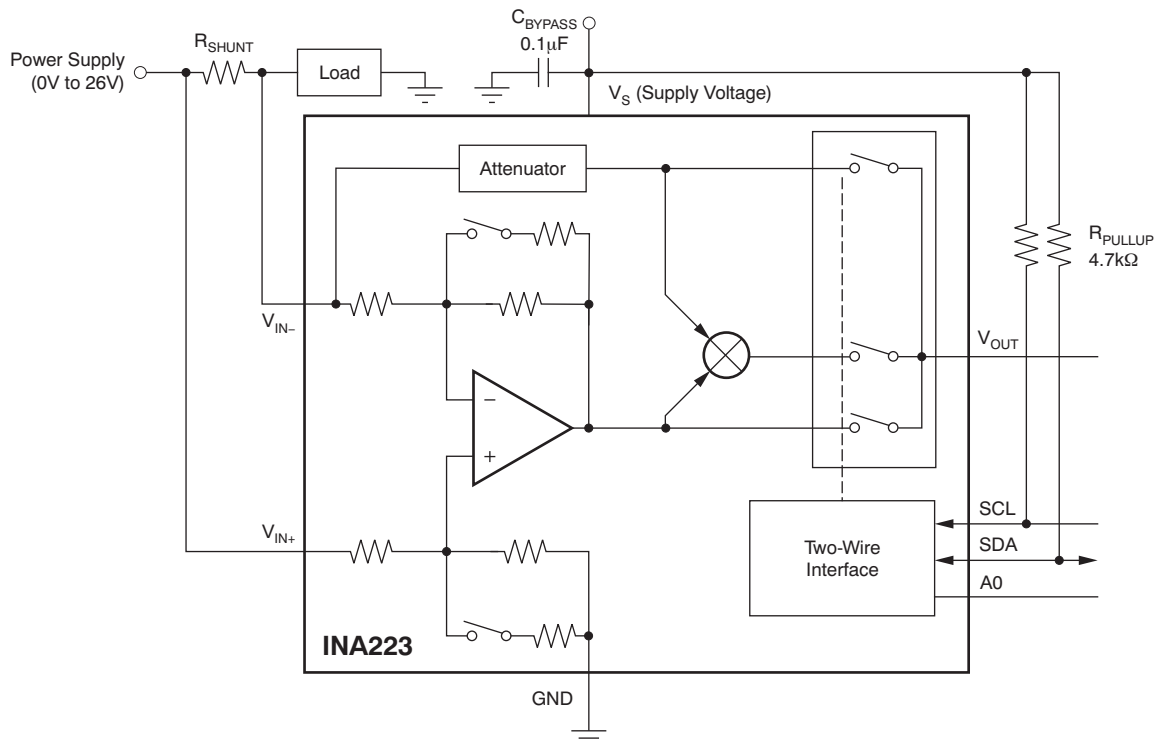

Figure 33. Typical Application

BASIC FUNCTIONS

The INA223 can be configured to monitor and report the differential voltage developed across a shunt resistor, the power supply bus voltage, or the power being delivered to the load. Through the two-wire interface, the output multiplexer (mux) can be configured to provide a proportional output signal to any one of these input signals at the output pin, V_{OUT} . The digital interface can also be used to switch between different current shunt voltage gains, bus voltage attenuation settings, as well as place the device into a disabled mode. The multiple settings available for the current shunt voltage gains and bus voltage attenuation factors allow the INA223 to operate over a wider input signal range than a single fixed-setting device would allow.

Shunt Voltage

The INA223 has three available current shunt voltage gain options that can be selected using the two-wire interface. This allows for optimization of the output signal to maximize the available dynamic range. This flexibility provides a benefit over a fixed-gain current shunt monitor. A fixed-gain current shunt monitor has a finite range of current that can be monitored based on the limitations of the output stage of the device.

For example, in a typical application using a fixed-gain current shunt monitor, the shunt resistor is selected to achieve the maximum allowable full-scale output based on the maximum expected current to be monitored and the fixed gain value of the current shunt monitor. One limitation to a fixed gain approach is in the minimum current level that can be monitored. The minimum current that can be monitored is based on the ability of the output stage of the current shunt monitor to swing to ground. This minimum current level is calculated based on the maximum swing to ground specification (50 mV for the INA223), which is then divided by the fixed gain of the device. This calculation provides the minimum differential voltage that can be monitored and then divided by the shunt resistor to determine the minimum current that can be monitored. After the monitored current drops below this level, further decreases in the monitored current can no longer be detected at the output. The ability to switch the current shunt voltage gain to a higher gain setting brings the output level above this saturation point and enables lower currents to be monitored, thus extending the dynamic range of the device.

Bus Voltage Range

The INA223 monitors bus voltages that can range from 0 V to 26 V. This voltage must be internally divided down to interface with the analog multiplier and output stage circuitry. The supply voltage for the INA223 can range from 2.7 V to 5.5 V; therefore, the bus voltage must be divided down so that it does not exceed the supply voltage. If this divider ratio or attenuation factor results in an internal voltage that exceeds the supply voltage, the measurement circuitry is saturated. The device will not be damaged, but the measurement result at the output will be invalid. Having multiple attenuation factors (0.1 V/V, 0.2 V/V, 0.4 V/V) allows for the optimization of the output range based on the specific common-mode voltage present. Having multiple values that can be selected provides a helpful advantage over a single fixed-attenuation device, given the wide common-mode range of the INA223. With a single attenuation factor, the maximum common-mode voltage (26 V) must be divided down to less than the minimum supply voltage (2.7 V). A bus voltage less than 26 V results in a significantly smaller output range. The ability to switch between different attenuation settings allows the device to be configured to maximize the dynamic output range at multiple common-mode voltage levels. Additionally, because the power calculation is based on the bus voltage measurement, the larger the corresponding representation of the common-mode voltage, the more accurate the power calculation.

Output Range

The power calculation has two inputs: the current shunt voltage measurement, as well as the bus voltage measurement. Both of these measurements must be valid (within the linear range of the device) to achieve a valid power calculation. Set the gain setting for the current shunt voltage and attenuation setting for the bus voltage to allow each of these two measurements to remain within the linear range of the device, based on the input conditions. Saturating one of these two measurements may not result in the output being saturated based on the internal scaling of the analog multiplier; therefore, care should be taken to ensure that the two inputs to the multiplier are valid.

Shutting Down the INA223

The INA223 includes a shutdown feature that is programmed through the serial interface. Setting the Enable bit in the Configuration Register to '0' places the INA223 into a disabled state. While in the disabled state, the input bias currents and device quiescent current drop below 1 μ A, thus reducing the power consumption of the system when this device is not in use. The device is placed back into the active mode by setting the Enable bit high. The time required for the INA223 output to be valid after enabling the device to come out of the shutdown state is typically 40 μ s.

In addition to responding to the Enable bit, the INA223 also responds to an Enable and Disable General Call as described in the [GENERAL CALL](#) section.

CONFIGURATION REGISTER

BIT	D15	D14	D13	D12	D11	D10	D9	D8	D7	D6	D5	D4	D3	D2	D1	D0
BIT NAME	—	—	—	—	—	—	—	—	—	EN	OUT1	OUT0	GSV1	GSV0	GBV1	GBV0
POR VALUE	0	0	0	0	0	0	0	0	0	1	1	0	0	0	0	1

EN Enable/Disable Mode

Bit 6 Setting this bit to '0' places the device into a disabled mode.

This mode drops the input bias current to 1 μ A for each of the analog inputs and reduces the quiescent current to 1 μ A.

OUT Output Mode

Bits 4, 5 Controls the setting of the output mux to select the signal that is available at the output pin. There are two different mode settings for selecting power at the output pin. The Supply Power output mode sets the bus voltage measurement to be taken at the V_{IN+} pin to calculate the power provided by the power supply. The Load Power output mode sets the bus voltage measurement to be taken at the V_{IN-} pin to calculate the power consumed by the load. Refer to [Table 1](#).

Table 1. Output Mode Settings⁽¹⁾

OUT1	OUT0	OUTPUT MODE
D5	D4	
0	0	Bus Voltage Measurement
0	1	Shunt Voltage Measurement
1	0	Supply Power
1	1	Load Power

(1) Shaded cells indicate default value.

GSV Current Shunt Voltage Gain

Bits 2, 3 Sets the gain for the current shunt voltage measurement. [Table 2](#) summarizes the gain settings.

Table 2. Current Shunt Voltage Gain Settings⁽¹⁾

GSV1	GSV0	CURRENT SHUNT VOLTAGE GAIN
D3	D2	
0	0	20 V/V
0	1	128 V/V
1	0	300 V/V

(1) Shaded cells indicate default value.

GBV Bus Voltage Gain

Bits 0, 1 Sets the gain for the bus voltage measurement. Refer to [Table 3](#).

Table 3. Bus Voltage Gain Settings⁽¹⁾

GBV1	GBV0	BUS VOLTAGE GAIN
D1	D0	
0	0	2/5 V/V
0	1	1/5 V/V
1	0	1/10 V/V

(1) Shaded cells indicate default value.

OUTPUT

The signal available at the output pin is selected by the output mode setting programmed in the Configuration Register. The default setting for the output mux is the Supply Power mode. For the power value to be valid, both the shunt voltage measurement and the bus voltage measurement must both be valid (within the linear range of the device).

Power Calculation

The output voltage for the two power output modes is calculated as shown in Equation 1. To convert the output voltage to the corresponding power representation, the output voltage must be divided by the product of the power gain shown in Table 4 and the value of the shunt resistor.

$$V_{OUT} = (V_{CM})(V_{SENSE})(POWER_{GAIN}) \tag{1}$$

$$POWER = \frac{V_{OUT}}{(POWER_{GAIN})(R_{SHUNT})} \tag{2}$$

Table 4. Power_{GAIN} Values

GBV	GSV	POWER _{GAIN}
0.1 V/V	20 V/V	0.667
0.1 V/V	128 V/V	4.267
0.1 V/V	300 V/V	10
0.2 V/V	20 V/V	1.333
0.2 V/V	128 V/V	8.533
0.2 V/V	300 V/V	20
0.4 V/V	20 V/V	2.667
0.4 V/V	128 V/V	17.067
0.4 V/V	300 V/V	40

Power Calculation Example

The following example is based on Figure 34. In this example the system consists of a load current of 5 A and a common-mode voltage of 12 V. This 5-A current flowing through the 1-mΩ shunt resistor develops a differential voltage of 5 mV across the INA223 input pins. With the 3.3-V supply voltage shown here, a practical full-scale target for the output voltage is 3 V.

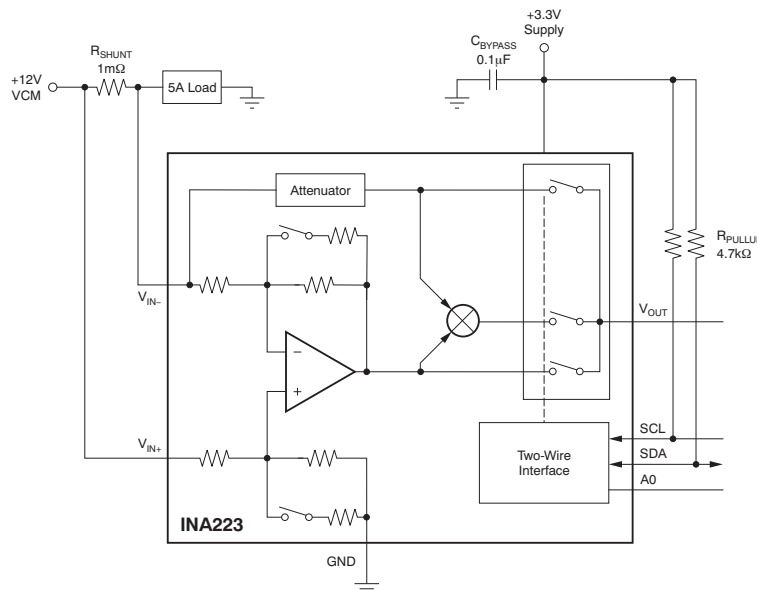

Figure 34. Example Circuit

Current Shunt Voltage Measurement Mode

Based on the 5-mV differential voltage present at the input and the device set to Current Shunt Voltage mode, a current shunt voltage gain setting of 300 V/V is selected resulting in an output voltage of 1.5 V. A current shunt voltage gain setting less than 300 V/V could also be used in this example. The drawback of a lower gain setting is a smaller dynamic range present at the output as well as a less accurate input for the power measurement in the Power Output mode. A larger shunt resistor (2 m Ω) could also be used to increase the full-scale drop to result. One drawback of increasing the impedance of the shunt resistor is the increased power dissipation requirement the component must be able to accommodate. A higher-accuracy power measurement is obtained with the largest possible input from the current shunt voltage, while remaining within the linear range of the device.

Bus Voltage Measurement Mode

Assuming the same 3-V target as previously discussed, and with the device set to Bus Voltage mode, an attenuation factor of 0.2 V/V results in an output voltage of 2.4 V. An attenuation factor of 0.1 V/V could also be used, but results in a lower dynamic output range. An attenuation factor of 0.4 V/V cannot be used in this example because it results in an internal voltage of 4.8 V, exceeding the supply voltage of 3.3 V.

Power Modes

For the power output modes, the current shunt voltage and bus voltage measurements are multiplied by the Power Gain factor to yield a voltage output representing the calculated power. In this example, the 5 mV developed across the shunt resistor is multiplied by the 12-V bus voltage. This product is then multiplied by the Power Gain factor of 20 (GSV = 300 V/V, GBV = 0.2 V/V; See [Table 4](#)), and results in a 1.2-V output voltage representation of the power. Using [Equation 2](#) and the corresponding Power Gain of 20, the power being consumed by the load is calculated to be 60 W. This corresponds to the original 5-A load current and 12-V common-mode voltage conditions.

Bus Voltage Measurement Location for Power Output Modes

For the power output mode, the bus voltage can be measured either at the V_{IN+} (supply side) or at the V_{IN-} (load side) pins when the current shunt voltage gain setting is 20. When the current shunt voltage gain setting is 128 or 300, this measurement assumes a relatively small differential voltage is being developed across the sense resistor. With a small drop across the sense resistor, the voltages at V_{IN+} and V_{IN-} are very close to one another, making the shunt voltage impact on the bus voltage measurement much less critical. When the device set to a gain of 20, it implies that a greater differential voltage is being developed across the sense resistor, causing the voltages at the V_{IN+} and V_{IN-} pins to be noticeably different. The power calculation can be configured to measure the bus voltage either at V_{IN+} (Supply Power) or at V_{IN-} (Load Power). If the power being supplied by the power supply is of interest, the Supply Power mode should be selected as the output mode setting. If the power being consumed by the load is of interest, the Load Power mode should be selected as the output mode setting. Note that the bus voltage measurement location is only available for the power calculation. For the Bus Voltage output mode, the bus voltage is always measured at the V_{IN+} pin.

Input Filtering

An obvious and straightforward location for filtering is at the output of the INA223. However, this location negates the advantage of the low output impedance of the internal buffer. The only other option for filtering is at the input pins of the INA223. [Figure 35](#) shows a filter placed at the inputs pins.

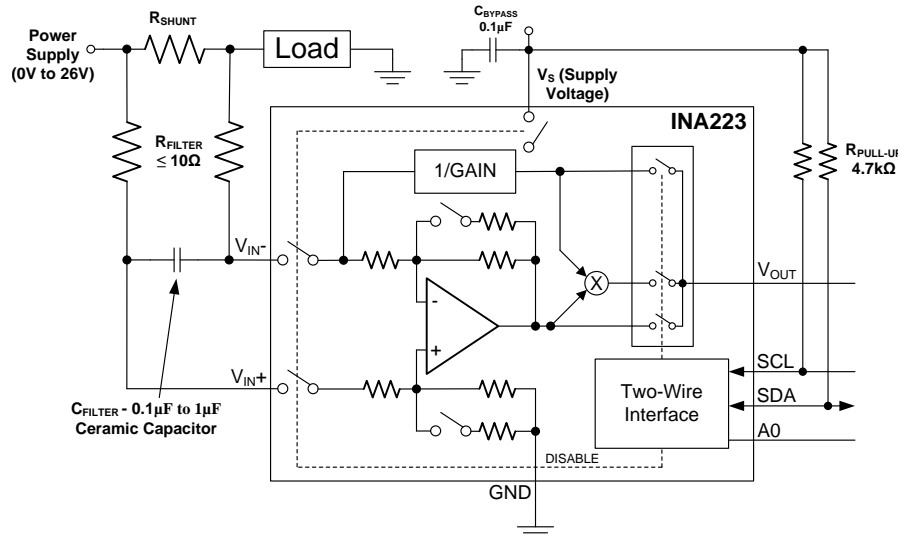

Figure 35. Input Filter

The addition of external series resistance, though, creates an additional error that is not present under normal operating conditions. An internal bias network at the input pins creates a mismatch in input bias currents when a differential voltage is applied to the device’s input pins. This results in a mismatch of voltage drops on the input lines due to the mismatch of input bias currents flowing through the additional external series filter resistors. This creates a differential error voltage that subtracts from the voltage developed at the shunt resistor. The result is a reduced differential voltage at the device input pins relative to the expected shunt voltage created by the load current flowing through the shunt resistor. Without the additional series resistance, the mismatch in input bias currents has little effect on the operation of the device.

The amount of variance in the differential voltage present directly at the input pins relative to the voltage developed at the shunt resistor is based both on values of external series resistance as well as the internal input resistors (R_{INT}), which is based on the shunt voltage gain setting as shown in [Table 5](#). The reduction of the shunt voltage reaching the device input pins appears as a gain error when looking at the output voltage relative to the shunt voltage. A factor can be calculated to determine the amount of gain error that is introduced by the addition of external series resistance. The equation used to calculate the expected deviation from the shunt voltage to what is seen at the device input pins is given in [Equation 3](#).

$$\text{Gain Error Factor} = \frac{(1250 \cdot R_{INT})}{(1250 \cdot R_S) + (1250 \cdot R_{INT}) + (R_S \cdot R_{INT})}$$

Where

- R_{INT} is the internal input resistance.
- R_S is the external series resistance.

(3)

With the adjustment factor equation including the device internal input resistance, this factor will vary with each gain setting.

Table 5. Internal Resistance Values

GAIN SETTING	R_{INT}
20	600 kΩ
128	93 kΩ
300	40 kΩ

Using The INA223 with Common-Mode Transients Above 26 V

The INA223 is designed for a maximum common-mode voltage of 26 V. In applications that may be subjected to transients above 26 V, the INA223 inputs must be protected. Figure 36 is the recommended method for protecting the INA223 to these transients. Use only zener diodes or zener-type transient absorbers (also known as a TransZorb™). Most other types of transient absorbers have an unacceptable time delay. The input resistors shown in Figure 36 should be kept as small as possible (less than 10 Ω) to limit the effects this resistance has on the gain, as discussed in the Input Filtering section.

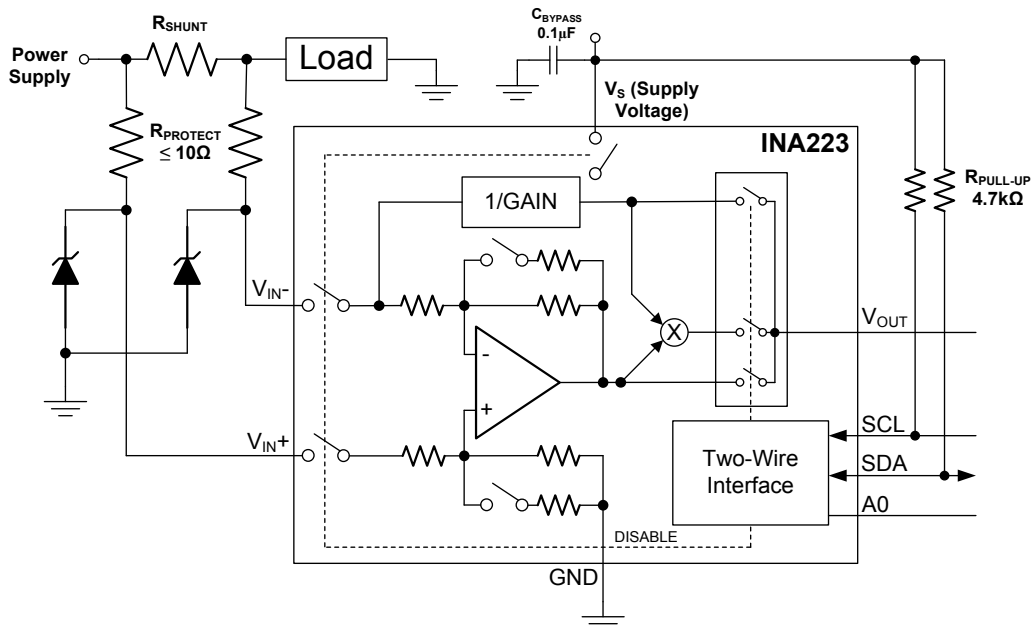

Figure 36. INA223 Transient Protection

Low-Side Current Sensing

The bus voltage of the INA223 is measured internally at the V_{IN+} pin, making it a high-side-only power monitor. However, the INA223 can be used for low-side current sensing, as shown in Figure 37 (as the common-mode voltage ranges from 0 V to 26 V).

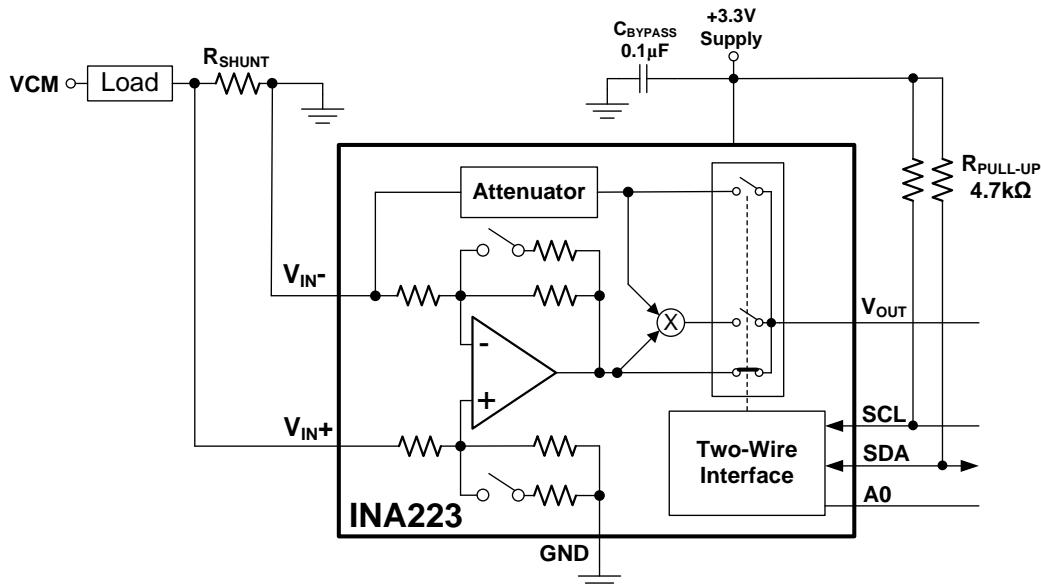
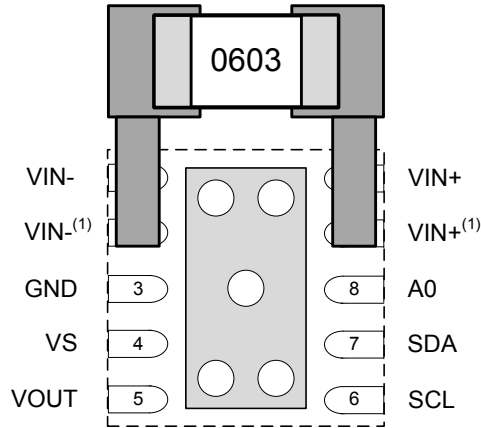

Figure 37. Low-Side Sensing with INA223

INA223 Recommended Layout

The recommended layout is shown in [Figure 38](#). Pins 2 and 9 should be connected directly to Pins 1 and 10, respectively. The shunt resistor should be placed as closely to the input pins, VIN+ and VIN-, to minimize any parasitics or added resistance. Use a four-wire, or kelvin, connection to the shunt to achieve the most accurate measurement across the shunt.



(1) See [Application Information](#) section for a description of how to connect input pins to the shunt resistor.

Figure 38. INA223 Recommended Layout

BUS OVERVIEW

The INA223 is compatible with both two-wire and SMBus interfaces. These protocols are essentially compatible with one another. The two-wire interface is used throughout this data sheet as the primary example, with the SMBus protocol specified only when a difference between the two systems is considered.

Two bidirectional lines, SCL and SDA, connect the INA223 to the bus. Both SCL and SDA are open-drain connections.

The device that initiates the transfer is called a *master*, and the devices controlled by the master are *slaves*. The bus must be controlled by a master device that generates the serial clock (SCL), controls the bus access, and generates *start* and *stop* conditions.

To address a specific device, the master initiates a *start* condition by pulling the data signal line (SDA) from a high to a low logic level while SCL is high. All slaves on the bus shift in the slave address byte on the rising edge of SCL, with the last bit indicating whether a read or write operation is intended. During the ninth clock pulse, the slave being addressed responds to the master by generating an acknowledge bit and pulling SDA low.

Data transfer is then initiated and eight bits of data are sent, followed by an acknowledge bit. During data transfer, SDA must remain stable while SCL is high. Any change in SDA while SCL is high is interpreted as a *start* or *stop* condition.

After all data have been transferred, the master generates a *stop* condition, indicated by pulling SDA from low to high while SCL is high. The INA223 includes a 28-ms timeout on its interface to prevent locking up the bus.

Serial Bus Address

To communicate with the INA223, the master must first address slave devices through a slave address byte. The slave address byte consists of seven address bits, and a direction bit that indicates the intent of executing a read or write operation.

The INA223 has one address pin, A0. [Table 6](#) describes the pin logic levels for each of the four possible addresses. The state of the A0 pin is sampled on every bus communication and should be set before any activity on the interface occurs. The address pins are read at the start of each communication event.

Table 6. INA223 Address Pins and Slave Addresses

A0	ADDRESS
GND	1000000
V _S	1000001
SDA	1000010
SCL	1000011

Serial Interface

The INA223 operates only as a slave device on both the two-wire bus and SMBus. Connections to the bus are made through the open-drain I/O lines, SDA and SCL. The SDA and SCL pins feature integrated spike suppression filters and Schmitt triggers to minimize the effects of input spikes and bus noise. The INA223 supports the transmission protocol for fast (1 kHz to 400 kHz) and high-speed (1 kHz to 3.4 MHz) modes. All data bytes are transmitted most significant byte first.

GENERAL CALL

The INA223 responds to three unique two-wire general call commands. A response occurs to a general call address (0000000) if the eighth bit is '0'. The device acknowledges the general call address and responds to commands based on the second byte. The three commands that the INA223 responds to are:

- General Call Reset (06h)
- General Call Enable (81h)
- General Call Disable (82h)

The INA223 responds to the General Call Reset by resetting all of the Configuration Registers settings to the respective default power-on values. The INA223 responds to a General Call Enable or General Call Disable by entering into or exiting from a disabled state. The INA223 can also be enabled and disabled by setting or clearing the enable/disable mode (EN) bit in the Configuration Register. The General Call Enable and General Call Disable commands allow for a single command to place multiple connected INA223 devices into either an enabled or disabled state.

WRITING TO AND READING FROM THE INA223

The INA223 has a single configuration register. This register is used to configure the INA223 based on how the device is to be used. This register can also be read to determine the register contents and the current device configuration.

Writing to the Configuration Register in the INA223 begins with the first byte transmitted by the master. This byte is the slave address, with the $\overline{R/W}$ bit low. The INA223 then acknowledges receipt of a valid address. The next two bytes are written to the register addressed by the register pointer. The INA223 acknowledges receipt of each data byte. The master may terminate data transfer by generating a *start* or *stop* condition.

When reading the Configuration Register in the INA223, the communication sequence begins the same with the first byte being transmitted by the master. This byte is the slave address, with the R/\overline{W} bit high. The INA223 then acknowledges receipt of a valid address. The next byte is transmitted by the slave and is the most significant byte of the register indicated by the register pointer. This byte is followed by an acknowledge bit from the master; then the slave transmits the least significant byte. The master acknowledges receipt of the data byte. The master may terminate data transfer by generating a not-acknowledge bit after receiving any data byte, or by generating a *start* or *stop* condition.

Figure 39 and Figure 40 show read and write operation timing diagrams, respectively. Note that register bytes are sent most-significant byte first, followed by the least significant byte.

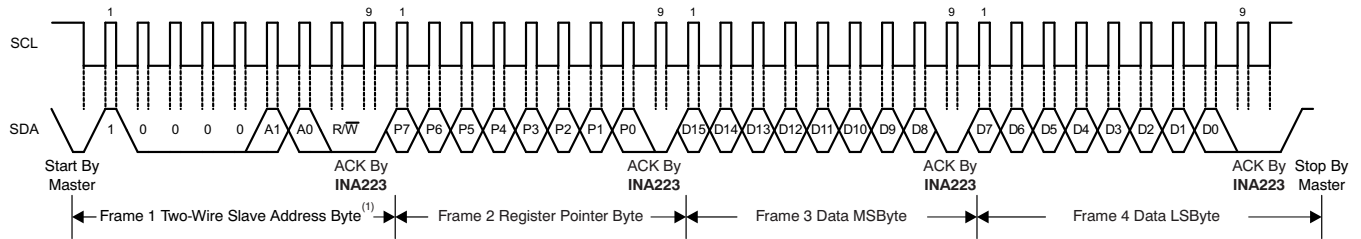

(1) The value of the Slave Address Byte is determined by the setting of the A0 pin. Refer to Table 1.

Figure 39. Timing Diagram for Write Word Format

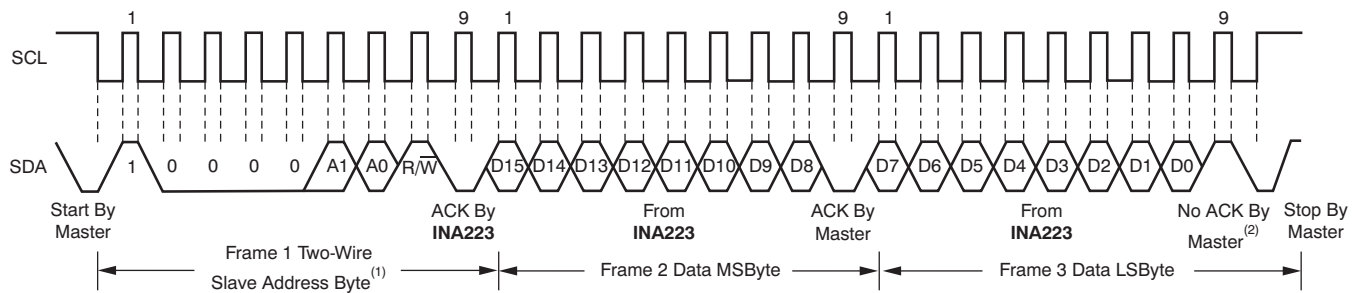

(1) The value of the Slave Address Byte is determined by the setting of the A0 pin. Refer to Table 1.

(2) ACK by master can also be sent.

Figure 40. Timing Diagram for Read Word Format

High-Speed Two-Wire Mode

When the bus is idle, both the SDA and SCL lines are pulled high by the pull-up devices. The master generates a *start* condition followed by a valid serial byte containing high-speed (HS) master code 00001XXX. This transmission is made in either fast (400 kHz) or standard (100 kHz) (F/S) mode at no more than 400 kHz. The INA223 does not acknowledge the HS master code, but recognizes it and switches its internal filters to support 3.4-MHz operation.

The master then generates a *repeated start* condition (a *repeated start* condition has the same timing as the *start* condition). After this *repeated start* condition, the protocol is the same as F/S mode, except that transmission speeds up to 3.4 MHz are allowed. Instead of using a *stop* condition, *repeated start* conditions should be used to secure the bus in HS-mode. A *stop* condition ends the HS-mode and switches all the internal filters of the INA223 to support the F/S mode. Figure 41 illustrates the bus timing. Corresponding definitions are listed in Table 7.

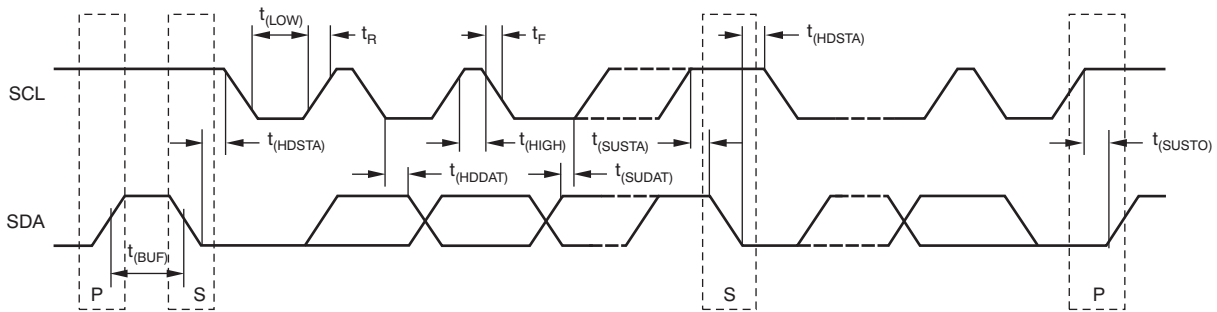

Figure 41. Bus Timing Diagram

Table 7. Bus Timing Diagram Definitions

SYMBOL	DESCRIPTION	FAST MODE		HIGH-SPEED MODE		UNITS
		MIN	MAX	MIN	MAX	
f _(SCL)	SCL operating frequency	0.001	0.4	0.001	3.4	MHz
t _(BUF)	Bus free time between <i>stop</i> and <i>start</i> conditions	600		160		ns
t _(HDSTA)	Hold time after <i>repeated start</i> condition. After this period, the first clock is generated.	100		100		ns
t _(SUSTA)	<i>Repeated start</i> condition setup time	100		100		ns
t _(SUSTO)	<i>Stop</i> condition setup time	100		100		ns
t _(HDDAT)	Data hold time	15		15		ns
t _(SUDAT)	Data setup time	100		10		ns
t _(LOW)	SCL clock low period	1300		160		ns
t _(HIGH)	SCL clock high period	600		60		ns
t _F	Clock/Data fall time		300		160	ns
t _R	Clock/Data rise time		300		160	ns
	Clock/Data rise time for SCLK ≤ 100 kHz		1000			ns

PACKAGING INFORMATION

Orderable Device	Status (1)	Package Type	Package Drawing	Pins	Package Qty	Eco Plan (2)	Lead finish/ Ball material (6)	MSL Peak Temp (3)	Op Temp (°C)	Device Marking (4/5)	Samples
INA223AIDSKR	ACTIVE	SON	DSK	10	3000	RoHS & Green	NIPDAU	Level-1-260C-UNLIM	-40 to 105	P223	Samples
INA223AIDSKT	ACTIVE	SON	DSK	10	250	RoHS & Green	NIPDAU	Level-1-260C-UNLIM	-40 to 105	P223	Samples

(1) The marketing status values are defined as follows:

ACTIVE: Product device recommended for new designs.

LIFEBUY: TI has announced that the device will be discontinued, and a lifetime-buy period is in effect.

NRND: Not recommended for new designs. Device is in production to support existing customers, but TI does not recommend using this part in a new design.

PREVIEW: Device has been announced but is not in production. Samples may or may not be available.

OBSOLETE: TI has discontinued the production of the device.

(2) **RoHS:** TI defines "RoHS" to mean semiconductor products that are compliant with the current EU RoHS requirements for all 10 RoHS substances, including the requirement that RoHS substance do not exceed 0.1% by weight in homogeneous materials. Where designed to be soldered at high temperatures, "RoHS" products are suitable for use in specified lead-free processes. TI may reference these types of products as "Pb-Free".

RoHS Exempt: TI defines "RoHS Exempt" to mean products that contain lead but are compliant with EU RoHS pursuant to a specific EU RoHS exemption.

Green: TI defines "Green" to mean the content of Chlorine (Cl) and Bromine (Br) based flame retardants meet JS709B low halogen requirements of <=1000ppm threshold. Antimony trioxide based flame retardants must also meet the <=1000ppm threshold requirement.

(3) MSL, Peak Temp. - The Moisture Sensitivity Level rating according to the JEDEC industry standard classifications, and peak solder temperature.

(4) There may be additional marking, which relates to the logo, the lot trace code information, or the environmental category on the device.

(5) Multiple Device Markings will be inside parentheses. Only one Device Marking contained in parentheses and separated by a "~" will appear on a device. If a line is indented then it is a continuation of the previous line and the two combined represent the entire Device Marking for that device.

(6) Lead finish/Ball material - Orderable Devices may have multiple material finish options. Finish options are separated by a vertical ruled line. Lead finish/Ball material values may wrap to two lines if the finish value exceeds the maximum column width.

Important Information and Disclaimer:The information provided on this page represents TI's knowledge and belief as of the date that it is provided. TI bases its knowledge and belief on information provided by third parties, and makes no representation or warranty as to the accuracy of such information. Efforts are underway to better integrate information from third parties. TI has taken and continues to take reasonable steps to provide representative and accurate information but may not have conducted destructive testing or chemical analysis on incoming materials and chemicals. TI and TI suppliers consider certain information to be proprietary, and thus CAS numbers and other limited information may not be available for release.

In no event shall TI's liability arising out of such information exceed the total purchase price of the TI part(s) at issue in this document sold by TI to Customer on an annual basis.

GENERIC PACKAGE VIEW

DSK 10

WSON - 0.8 mm max height

2.5 x 2.5 mm, 0.5 mm pitch

PLASTIC SMALL OUTLINE - NO LEAD

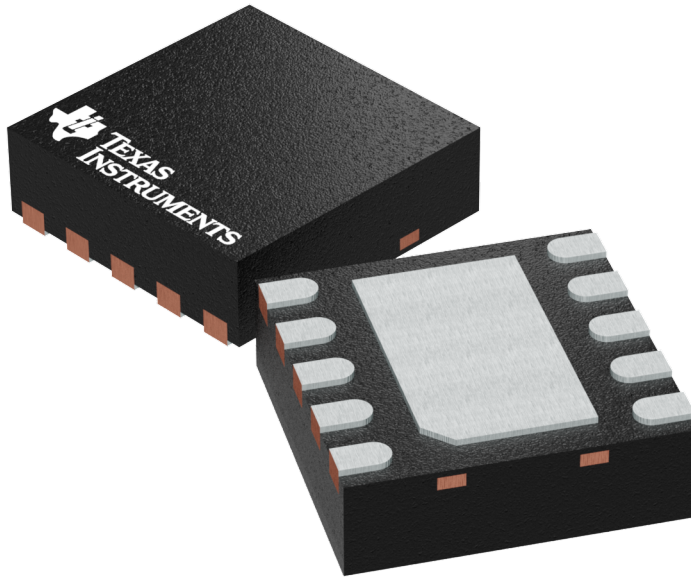

Images above are just a representation of the package family, actual package may vary.
Refer to the product data sheet for package details.

4225304/A

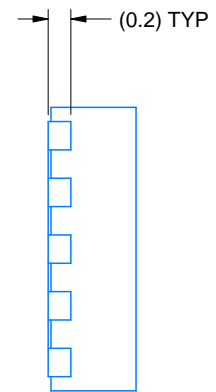
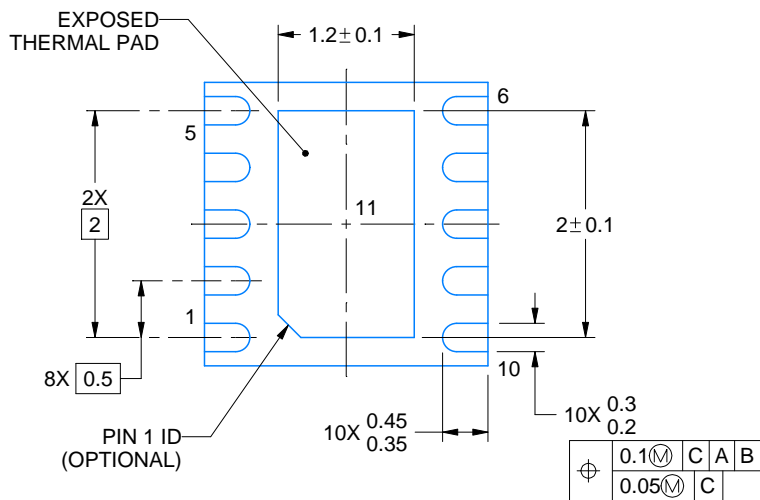
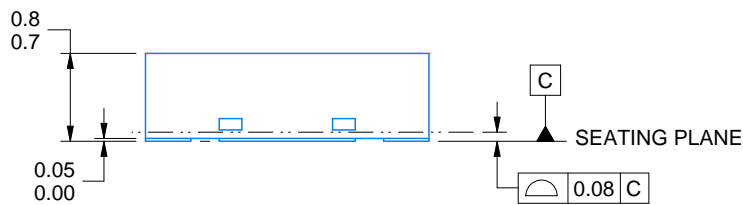
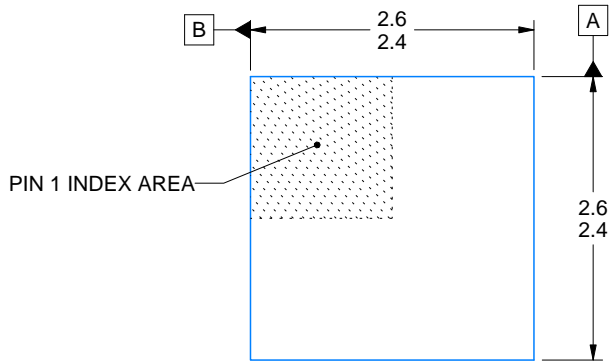
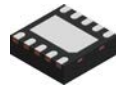

4218903/B 10/2020

NOTES:

1. All linear dimensions are in millimeters. Any dimensions in parenthesis are for reference only. Dimensioning and tolerancing per ASME Y14.5M.
2. This drawing is subject to change without notice.
3. The package thermal pad must be soldered to the printed circuit board for thermal and mechanical performance.

EXAMPLE BOARD LAYOUT

DSK0010A

WSON - 0.8 mm max height

PLASTIC SMALL OUTLINE - NO LEAD

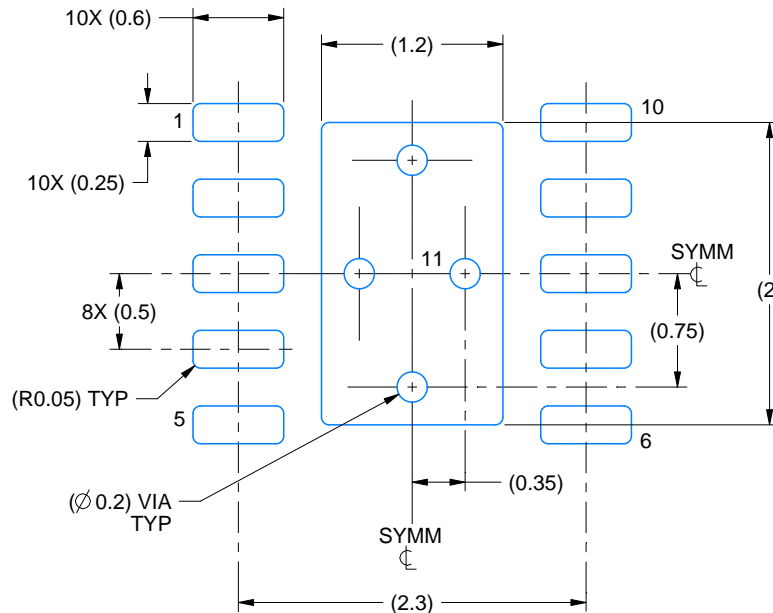

LAND PATTERN EXAMPLE
SCALE:20X

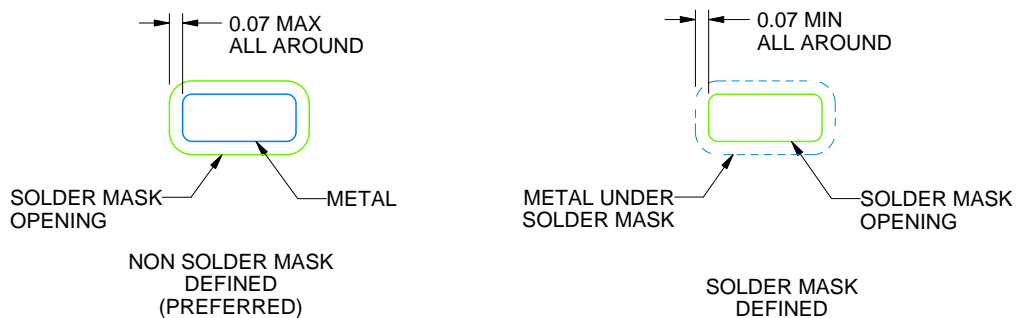

SOLDER MASK DETAILS

4218903/B 10/2020

NOTES: (continued)

4. This package is designed to be soldered to a thermal pad on the board. For more information, see Texas Instruments literature number SLUA271 (www.ti.com/lit/slue271).
5. Vias are optional depending on application, refer to device data sheet. If some or all are implemented, recommended via locations are shown.

EXAMPLE STENCIL DESIGN

DSK0010A

WSON - 0.8 mm max height

PLASTIC SMALL OUTLINE - NO LEAD

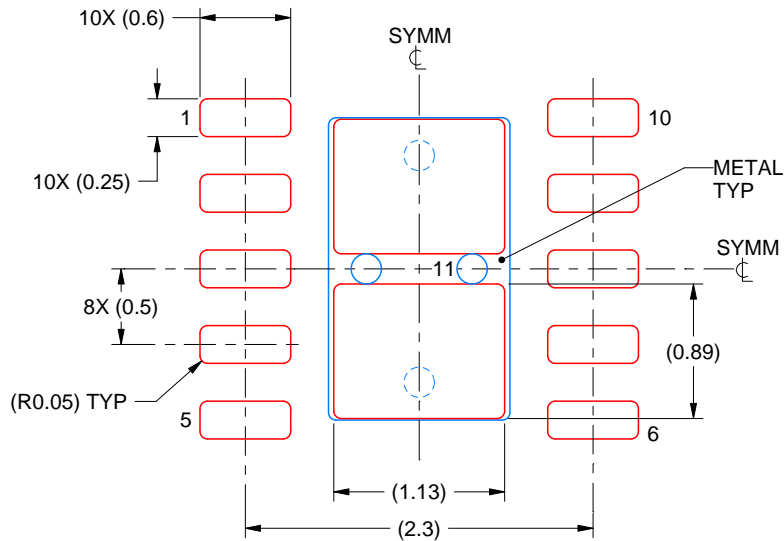

SOLDER PASTE EXAMPLE
BASED ON 0.125 mm THICK STENCIL

EXPOSED PAD 11
84% PRINTED SOLDER COVERAGE BY AREA
SCALE:20X

4218903/B 10/2020

NOTES: (continued)

6. Laser cutting apertures with trapezoidal walls and rounded corners may offer better paste release. IPC-7525 may have alternate design recommendations.

重要声明和免责声明

TI 均以“原样”提供技术性及其可靠性数据（包括数据表）、设计资源（包括参考设计）、应用或其他设计建议、网络工具、安全信息和其他资源，不保证其中不含任何瑕疵，且不做任何明示或暗示的担保，包括但不限于对适销性、适合某特定用途或不侵犯任何第三方知识产权的暗示担保。

所述资源可供专业开发人员应用TI 产品进行设计使用。您将对以下行为独自承担全部责任：(1) 针对您的应用选择合适的TI 产品；(2) 设计、验证并测试您的应用；(3) 确保您的应用满足相应标准以及任何其他安全、安保或其他要求。所述资源如有变更，恕不另行通知。TI 对您使用所述资源的授权仅限于开发资源所涉及TI 产品的相关应用。除此之外不得复制或展示所述资源，也不提供其它TI 或任何第三方的知识产权授权许可。如因使用所述资源而产生任何索赔、赔偿、成本、损失及债务等，TI 对此概不负责，并且您须赔偿由此对TI 及其代表造成的损害。

TI 所提供产品均受TI 的销售条款 (<http://www.ti.com.cn/zh-cn/legal/termsofsale.html>) 以及ti.com.cn 上或随附TI 产品提供的其他可适用条款的约束。TI 提供所述资源并不扩展或以其他方式更改TI 针对TI 产品所发布的可适用的担保范围或担保免责声明。

邮寄地址：上海市浦东新区世纪大道 1568 号中建大厦 32 楼，邮政编码：200122
Copyright © 2020 德州仪器半导体技术（上海）有限公司