

# SN75ALS056, SN75ALS057 TRAPEZOIDAL-WAVEFORM INTERFACE BUS TRANSCEIVERS

SLLS028G – AUGUST 1987 – REVISED JUNE 1998

- Suitable for IEEE Standard 896 Applications†
- SN75ALS056 is an Octal Transceiver
- SN75ALS057 is a Quad Transceiver
- High-Speed Advanced Low-Power Schottky (ALS) Circuitry
- Low Power Dissipation:  
52.5 mW/Channel Max
- High-Impedance pnp Inputs
- Logic-Level 1-V Bus Swing Reduces Power Consumption
- Trapezoidal Bus Output Waveform Reduces Noise Coupling to Adjacent Lines
- Power-Up/Power-Down Protection (Glitch Free)
- Open-Collector Driver Outputs Allow Wired-OR Connections
- Designed to Be a Faster, Lower-Power Functional Equivalent of National DS3896, DS3897

## description

The SN75ALS056 is an eight-channel, monolithic, high-speed, advanced low-power Schottky (ALS) device designed for two-way data communication in a densely populated backplane. The SN75ALS057 is a four-channel version with independent driver-input (Dn) and receiver-output (Rn) pins and a separate driver disable for each driver (En).

These transceivers feature open-collector driver outputs with series Schottky diodes to reduce capacitive loading to the bus. By using a 2-V pullup termination on the bus, the output signal swing is approximately 1 V, which reduces the power necessary to drive the bus load capacitance. The driver outputs generate trapezoidal waveforms that reduce crosstalk between channels. The drivers are capable of driving an equivalent dc load as low as 18.5 Ω. The receivers have internal low-pass filters to further improve noise immunity.

The SN75ALS056 and SN75ALS057 are characterized for operation from 0°C to 70°C.

SN75ALS056 . . . DW OR N PACKAGE  
(TOP VIEW)

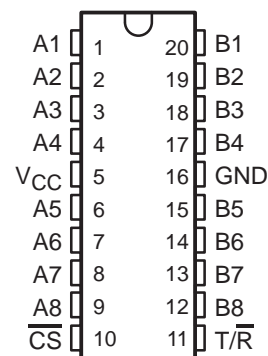

SN75ALS057 . . . DW OR N PACKAGE  
(TOP VIEW)

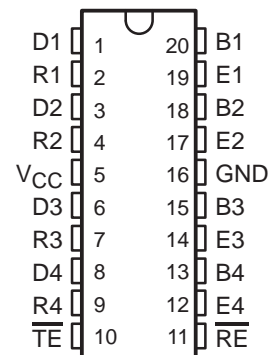

Please be aware that an important notice concerning availability, standard warranty, and use in critical applications of Texas Instruments semiconductor products and disclaimers thereto appears at the end of this data sheet.

† The transceivers are suitable for IEEE Standard 896 applications to the extent of the operating conditions and characteristics specified in this data sheet.

PRODUCTION DATA information is current as of publication date. Products conform to specifications per the terms of Texas Instruments standard warranty. Production processing does not necessarily include testing of all parameters.

 **TEXAS  
INSTRUMENTS**

POST OFFICE BOX 655303 • DALLAS, TEXAS 75265

Copyright © 1998, Texas Instruments Incorporated

# SN75ALS056, SN75ALS057 TRAPEZOIDAL-WAVEFORM INTERFACE BUS TRANSCEIVERS

SLLS028G – AUGUST 1987 – REVISED JUNE 1998

## logic symbol†

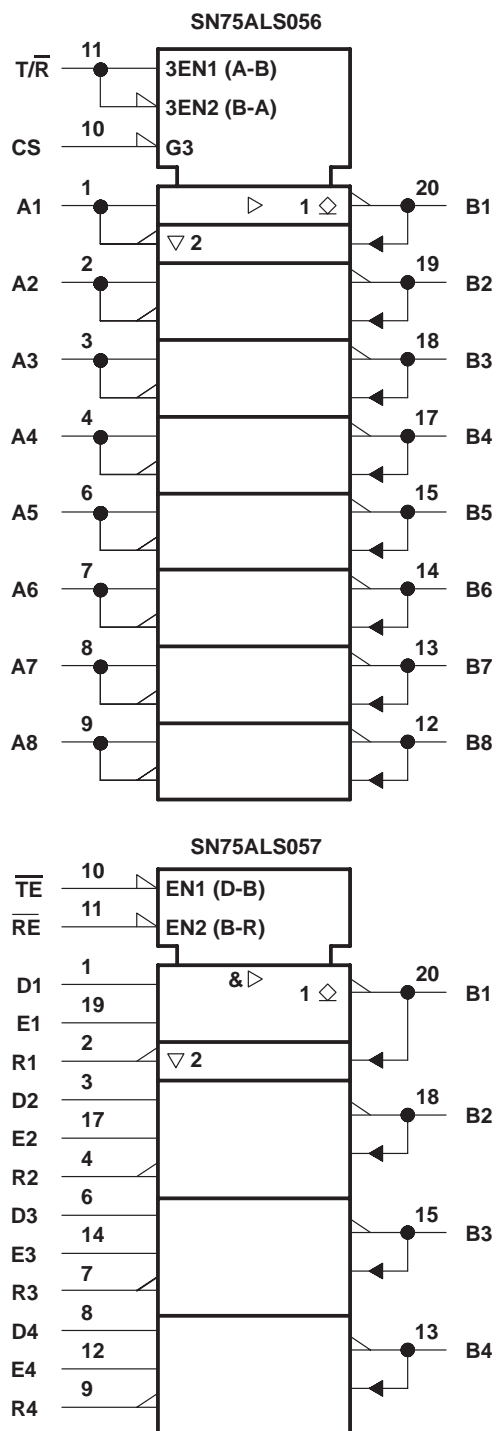

† These symbols are in accordance with ANSI/IEEE Std 91-1984 and IEC Publication 617-12.

# SN75ALS056, SN75ALS057 TRAPEZOIDAL-WAVEFORM INTERFACE BUS TRANSCEIVERS

SLLS028G – AUGUST 1987 – REVISED JUNE 1998

## logic diagram (positive logic)

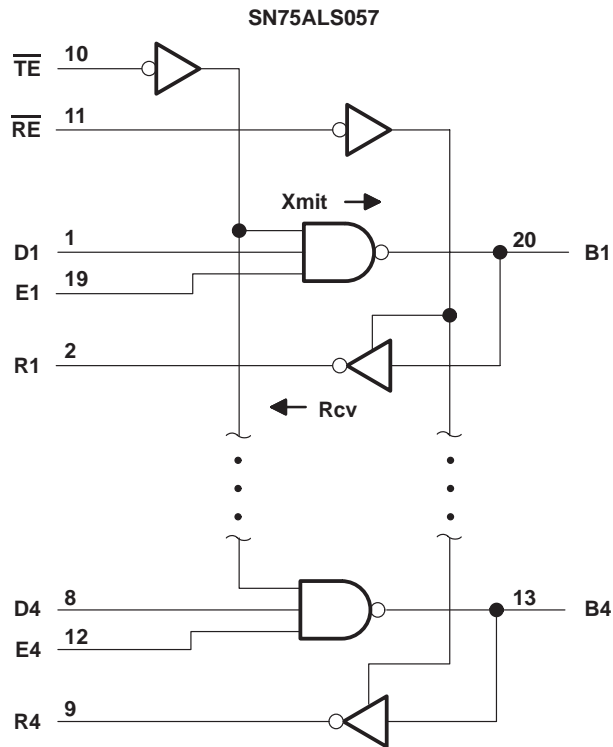
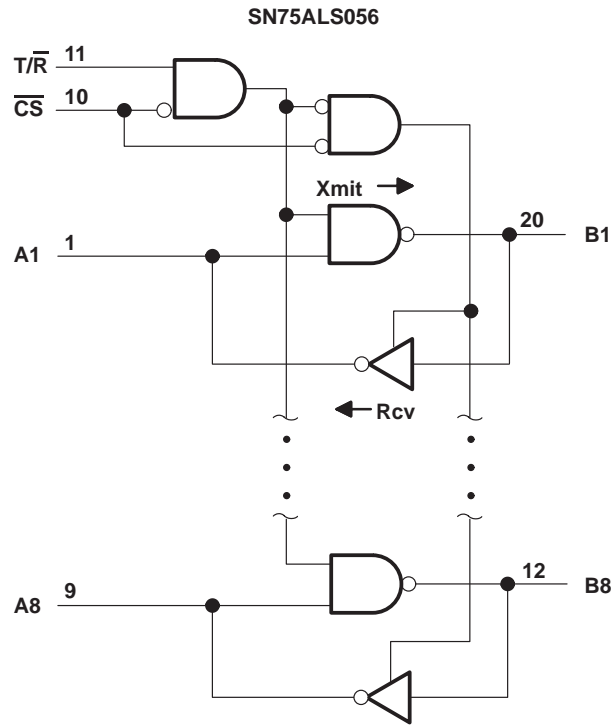

† These symbols are in accordance with ANSI/IEEE Std 91-1984 and IEC Publication 617-12.

# SN75ALS056, SN75ALS057 TRAPEZOIDAL-WAVEFORM INTERFACE BUS TRANSCEIVERS

SLLS028G – AUGUST 1987 – REVISED JUNE 1998

## Function Tables

SN75ALS056  
TRANSMIT/RECEIVE

CONTROLS		CHANNELS
$\overline{CS}$	$T/\overline{R}$	A $\leftrightarrow$ B
L	H	T(A B)
L	L	R(B A)
H	X	D

SN75ALS057  
TRANSMIT/RECEIVE

CONTROLS			CHANNELS			
$\overline{TE}$	$\overline{RE}$	En	D	B	B	R
L	L	L	D			R
L	L	H	T			R
L	H	L	D			D
L	H	H	T			D
H	L	X	D			R
H	H	X	D			D

H = high level, L = low level, R = receive, T = transmit,  
D = disable, X = irrelevant

Direction of data transmission is from An to Bn for the SN75ALS056 and from Dn to Bn for the SN75ALS057. Direction of data reception is from Bn to An for the SN75ALS056 and from Bn to Rn for the SN75ALS057. Data transfer is inverting in both directions.

# SN75ALS056, SN75ALS057 TRAPEZOIDAL-WAVEFORM INTERFACE BUS TRANSCEIVERS

SLLS028G – AUGUST 1987 – REVISED JUNE 1998

## schematics of inputs and outputs

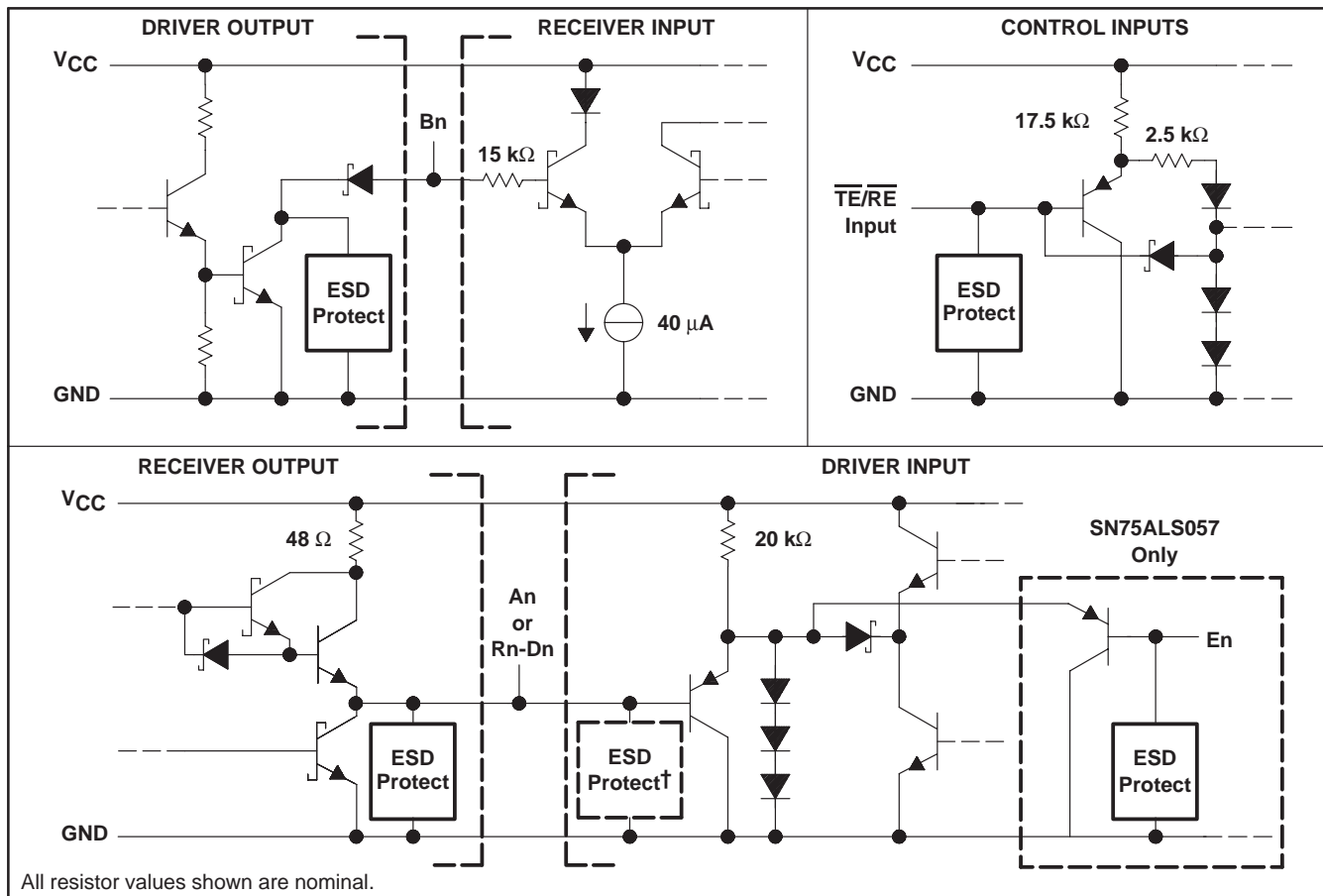

† Additional ESD protection is on the SN75ALS057, which has separate receiver-output and driver-input pins.

## absolute maximum ratings over operating free-air temperature (unless otherwise noted)‡

Supply voltage, $V_{CC}$ (see Note 1)	6 V
Control input voltage, $V_I$	5.5 V
Driver input voltage, $V_I$	5.5 V
Driver output voltage, $V_O$	2.5 V
Receiver input voltage, $V_I$	2.5 V
Receiver output voltage, $V_O$	5.5 V
Continuous total power dissipation	See Dissipation Rating Table
Storage temperature range, $T_{stg}$	-65°C to 150°C
Lead temperature 1,6 mm (1/16 inch) from case for 10 seconds: DW or N package	260 °C

‡ Stresses beyond those listed under "absolute maximum ratings" may cause permanent damage to the device. These are stress ratings only, and functional operation of the device at these or any other conditions beyond those indicated under "recommended operating conditions" is not implied. Exposure to absolute-maximum-rated conditions for extended periods may affect device reliability.

NOTE 1: Voltage values are with respect to network ground terminal.

# SN75ALS056, SN75ALS057 TRAPEZOIDAL-WAVEFORM INTERFACE BUS TRANSCEIVERS

SLLS028G – AUGUST 1987 – REVISED JUNE 1998

DISSIPATION RATING TABLE

PACKAGE	$T_A \leq 25^\circ\text{C}$ POWER RATING	DERATING FACTOR ABOVE $T_A = 25^\circ\text{C}$	$T_A = 70^\circ\text{C}$ POWER RATING	$T_A = 125^\circ\text{C}$ POWER RATING
DW	1025 mW	8.2 mW/ $^\circ\text{C}$	656 mW	—
N	1150 mW	9.2 mW/ $^\circ\text{C}$	736 mW	—

## recommended operating conditions

	MIN	NOM	MAX	UNIT
Supply voltage, $V_{CC}$	4.75	5	5.25	V
High-level driver and control input voltage, $V_{IH}$	2			V
Low-level driver and control input voltage, $V_{IL}$			0.8	V
Bus termination voltage	1.9		2.1	V
Operating free-air temperature, $T_A$	0		70	$^\circ\text{C}$

## electrical characteristics over recommended ranges of supply voltage and operating free-air temperature (unless otherwise noted)

PARAMETER		TEST CONDITION <sup>†</sup>	SN75ALS056			UNIT
			MIN	TYP <sup>†</sup>	MAX	
$V_{IK}$	Input clamp voltage at An, $\overline{T/R}$ , or $\overline{CS}$	$I_I = -18 \text{ mA}$			-1.5	V
$V_{IT}$	Receiver input threshold voltage at Bn		1.405		1.69	V
$V_{OH}$	High-level output voltage at An	Bn at 1.2 V, $\overline{CS}$ at 0.8 V, $\overline{T/R}$ at 0.8 V, $I_{OH} = -400 \mu\text{A}$	2.4			V
$V_{OL}$	Low-level output voltage	An			0.5	V
		Bn	An at 2 V, $\overline{CS}$ at 0.8 V, $\overline{T/R}$ at 2 V, $V_L = 2 \text{ V}$ , $R_L = 18.5 \Omega$ , See Figure 1	0.75	1.2	
$I_{IH}$	High-level input current	An, $\overline{T/R}$ or $\overline{CS}$			40	$\mu\text{A}$
		Bn	$V_I = 2 \text{ V}$ , $V_{CC} = 0$ or 5.25 V, An at 0.8 V, $\overline{T/R}$ at 0.8 V		100	
$I_{IL}$	Low level input current at An, $\overline{T/R}$ , or $\overline{CS}$	$V_I = 0.4 \text{ V}$			-400	$\mu\text{A}$
$I_{OS}$	Short-circuit output current at An	An at 0, Bn at 1.2 V, $\overline{CS}$ at 0.8 V, $\overline{T/R}$ at 0.8 V	-40		-120	mA
$I_{CC}$	Supply current				75	mA
$C_{O(B)}$	Driver output capacitance				4.5	pF

<sup>†</sup> Typical values are at  $V_{CC} = 5 \text{ V}$ ,  $T_A = 25^\circ\text{C}$ .



# SN75ALS056, SN75ALS057 TRAPEZOIDAL-WAVEFORM INTERFACE BUS TRANSCEIVERS

SLLS028G – AUGUST 1987 – REVISED JUNE 1998

**electrical characteristics over recommended ranges of supply voltage and operating free-air temperature (unless otherwise noted)**

PARAMETER		TEST CONDITIONS	SN75ALS057			UNIT
			MIN	TYP†	MAX	
V <sub>IK</sub>	Input clamp voltage at Dn, En, $\overline{TE}$ , or $\overline{RE}$	I <sub>I</sub> = -18 mA			-1.5	V
V <sub>IT</sub>	Receiver input threshold voltage at Bn		1.41		1.69	V
V <sub>OH</sub>	High-level output voltage at Rn	Bn at 1.2 V, $\overline{RE}$ at 0.8 V, I <sub>OH</sub> = -400 $\mu$ A	2.4			V
V <sub>OL</sub>	Low-level output voltage	Rn			0.5	V
		Bn	Dn at 2 V, En at 2 V, $\overline{TE}$ at 0.8 V, V <sub>L</sub> = 2 V, R <sub>L</sub> = 18.5 $\Omega$ , See Figure 1	0.75	1.2	
I <sub>IH</sub>	High-level input current	Dn, En, $\overline{TE}$ , or $\overline{RE}$			40	$\mu$ A
		Bn	V <sub>I</sub> = V <sub>CC</sub> V <sub>I</sub> = 2 V, V <sub>CC</sub> = 0 or 5.25 V, Dn at 0.8 V, En at 0.8 V, $\overline{TE}$ at 0.8 V		100	
I <sub>IL</sub>	Low-level input current at Dn, En, $\overline{TE}$ , or $\overline{RE}$	V <sub>I</sub> = 0.4 V			-400	$\mu$ A
I <sub>OS</sub>	Short-circuit output current at Rn	Rn at 0, Bn at 1.2 V, $\overline{RE}$ at 0.8 V	-40		-120	mA
I <sub>CC</sub>	Supply current				40	mA
C <sub>O(B)</sub>	Driver output capacitance				4.5	pF

† Typical values are at V<sub>CC</sub> = 5 V, T<sub>A</sub> = 25°C.

**switching characteristics over recommended ranges of supply voltage and operating free-air temperature (unless otherwise noted)**

PARAMETER	FROM (INPUT)	TO (OUTPUT)	TEST CONDITIONS	SN75ALS056 DRIVER			UNIT
				MIN	TYP†	MAX	
t <sub>PLH1</sub>	$\overline{CS}$	Bn	An and T/ $\overline{R}$ at 2 V, V <sub>L</sub> = 2 V, R <sub>L1</sub> = 18 $\Omega$ , C <sub>L</sub> = 30 pF, R <sub>L2</sub> not connected, See Figure 2			24	ns
t <sub>PHL1</sub>						20	
t <sub>PLH2</sub>	An	Bn	$\overline{CS}$ at 0.8 V, T/ $\overline{R}$ at 2 V, V <sub>L</sub> = 2 V, R <sub>L1</sub> = 18 $\Omega$ , R <sub>L2</sub> not connected, C <sub>L</sub> = 30 pF, See Figure 2,			19	ns
t <sub>PHL2</sub>						18	
t <sub>PLH3</sub>	T/ $\overline{R}$	Bn	V <sub>I</sub> (An) = 5 V, $\overline{CS}$ at 0.8 V, R <sub>L1</sub> = 18 $\Omega$ , C <sub>L</sub> = 30 pF, R <sub>L2</sub> not connected, V <sub>L</sub> = 2 V, See Figure 3,			25	ns
t <sub>PHL3</sub>						35	
t <sub>TLH</sub>	An	Bn	$\overline{CS}$ at 0.8 V, T/ $\overline{R}$ at 2 V, V <sub>L</sub> = 2 V, C <sub>L</sub> = 30 pF, R <sub>L1</sub> = 18 $\Omega$ , R <sub>L2</sub> not connected, See Figure 2	1	3	11	ns
t <sub>THL</sub>				1	3	6	

† Typical values are at V<sub>CC</sub> = 5 V, T<sub>A</sub> = 25°C



# SN75ALS056, SN75ALS057 TRAPEZOIDAL-WAVEFORM INTERFACE BUS TRANSCEIVERS

SLLS028G – AUGUST 1987 – REVISED JUNE 1998

switching characteristics over recommended ranges of supply voltage and operating free-air temperature (unless otherwise noted)

PARAMETER	FROM (INPUT)	TO (OUTPUT)	TEST CONDITIONS	SN75ALS056 RECEIVER		UNIT
				MIN	MAX	
t <sub>PLH4</sub>	Bn	An	$\overline{CS}$ at 0.8 V, T/R at 0.8 V, R <sub>L1</sub> = 390 Ω, R <sub>L2</sub> = 1.6 kΩ, C <sub>L</sub> = 30 pF, See Figure 4	18		ns
t <sub>PHL4</sub>				18		
t <sub>PLZ1</sub>	T/R	An	$\overline{CS}$ at 0.8 V, V <sub>I(Bn)</sub> = 2 V, V <sub>L</sub> = 5 V, R <sub>L1</sub> = 390 Ω, R <sub>L2</sub> not connected, C <sub>L</sub> = 15 pF, See Figure 3	20		ns
t <sub>PZL1</sub>	T/R	An	$\overline{CS}$ at 0.8 V, V <sub>I(Bn)</sub> = 2 V, V <sub>L</sub> = 5 V, R <sub>L1</sub> = 390 Ω, R <sub>L2</sub> = 1.6 kΩ, C <sub>L</sub> = 30 pF, See Figure 3	40		ns
t <sub>PHZ1</sub>	T/R	An	$\overline{CS}$ at 0.8 V, V <sub>I(Bn)</sub> = 0, V <sub>L</sub> = 0, R <sub>L1</sub> = 390 Ω, R <sub>L2</sub> not connected, C <sub>L</sub> = 15 pF, See Figure 3	17		ns
t <sub>PZH1</sub>	T/R	An	$\overline{CS}$ at 0.8 V, V <sub>I(Bn)</sub> = 0, V <sub>L</sub> = 0, R <sub>L1</sub> not connected, R <sub>L2</sub> = 1.6 kΩ, C <sub>L</sub> = 30 pF, See Figure 3	15		ns
t <sub>PLZ2</sub>	$\overline{CS}$	An	Bn at 2 V, T/R at 0.8 V, C <sub>L</sub> = 5 pF, V <sub>L</sub> = 5 V, R <sub>L1</sub> = 390 Ω, R <sub>L2</sub> not connected, See Figure 5	18		ns
t <sub>PZL2</sub>	$\overline{CS}$	An	Bn at 2 V, T/R at 0.8 V, C <sub>L</sub> = 30 pF, V <sub>L</sub> = 5 V, R <sub>L1</sub> = 390 Ω, R <sub>L2</sub> = 1.6 kΩ, See Figure 5	15		ns
t <sub>PHZ2</sub>	$\overline{CS}$	An	Bn at 0.8 V, T/R at 0.8 V, C <sub>L</sub> = 5 pF, V <sub>L</sub> = 0, R <sub>L1</sub> = 390 Ω, R <sub>L2</sub> not connected, See Figure 5	8		ns
t <sub>PZH2</sub>	$\overline{CS}$	An	Bn at 0.8 V, T/R at 0.8 V, C <sub>L</sub> = 30 pF, V <sub>L</sub> = 0, R <sub>L1</sub> not connected, R <sub>L2</sub> = 1.6 kΩ, See Figure 5	17		ns
t <sub>w(NR)</sub>	Bn	An	$\overline{CS}$ at 0.8 V, T/R at 0.8 V, R <sub>L1</sub> = 390 Ω, R <sub>L2</sub> = 1.6 kΩ, C <sub>L</sub> = 30 pF, V <sub>L</sub> = 5 V, See Figure 6	3		ns



# SN75ALS056, SN75ALS057 TRAPEZOIDAL-WAVEFORM INTERFACE BUS TRANSCEIVERS

SLLS028G – AUGUST 1987 – REVISED JUNE 1998

**switching characteristics over recommended ranges of supply voltage and operating free-air temperature (unless otherwise noted)**

PARAMETER	FROM (INPUT)	TO (OUTPUT)	TEST CONDITIONS	SN75ALS057 DRIVER			UNIT
				MIN	TYP†	MAX	
t <sub>PLH1</sub>	$\overline{TE}$	Bn	Dn, En, $\overline{RE}$ at 2 V, V <sub>L</sub> = 2 V, R <sub>L2</sub> not connected, R <sub>L1</sub> = 18 Ω, See Figure 2, C <sub>L</sub> = 30 pF	24			ns
t <sub>PHL1</sub>				20			
t <sub>PLH2</sub>	Dn or En	Bn	$\overline{TE}$ at 0.8 V, $\overline{RE}$ at 2 V, V <sub>L</sub> = 2 V, R <sub>L1</sub> = 18 Ω, R <sub>L2</sub> not connected, C <sub>L</sub> = 30 pF, See Figure 2	19			ns
t <sub>PHL2</sub>				18			
t <sub>TLH</sub>	Dn or En	Bn	$\overline{RE}$ at 2 V, V <sub>L</sub> = 2 V, $\overline{TE}$ at 0.8 V, R <sub>L1</sub> = 18 Ω, R <sub>L2</sub> not connected, C <sub>L</sub> = 30 pF, See Figure 2	1	3	11	ns
t <sub>THL</sub>				1	3	6	

† Typical values are at V<sub>CC</sub> = 5 V, T<sub>A</sub> = 25°C.

**switching characteristics over recommended ranges of supply voltage and operating free-air temperature (unless otherwise noted) (continued)**

PARAMETER	FROM (INPUT)	TO (OUTPUT)	TEST CONDITIONS	SN75ALS057 RECEIVER		UNIT
				MIN	MAX	
t <sub>PLH4</sub>	Bn	Rn	$\overline{RE}$ at 0.8 V, $\overline{TE}$ at 2 V, V <sub>L</sub> = 5 V, R <sub>L1</sub> = 390 Ω, R <sub>L2</sub> = 1.6 kΩ, C <sub>L</sub> = 30 pF, See Figure 4	18		ns
t <sub>PHL4</sub>				18		
t <sub>PLZ2</sub>	$\overline{RE}$	Rn	Bn at 2 V, $\overline{TE}$ at 2 V, V <sub>L</sub> = 5 V, C <sub>L</sub> = 5 pF, R <sub>L1</sub> = 390 Ω, R <sub>L2</sub> not connected, See Figure 5	18		ns
t <sub>PZL2</sub>	$\overline{RE}$	Rn	Bn at 2 V, $\overline{TE}$ at 2 V, V <sub>L</sub> = 5 V, C <sub>L</sub> = 30 pF, R <sub>L1</sub> = 390 Ω, R <sub>L2</sub> = 1.6 kΩ, See Figure 5	15		ns
t <sub>PHZ2</sub>	$\overline{RE}$	Rn	Bn at 0.8 V, $\overline{TE}$ at 2 V, V <sub>L</sub> = 0, C <sub>L</sub> = 5 pF, R <sub>L1</sub> = 390 Ω, R <sub>L2</sub> not connected, See Figure 5	17		ns
t <sub>PZH2</sub>	$\overline{RE}$	Rn	Bn at 0.8 V, $\overline{TE}$ at 2 V, V <sub>L</sub> = 0, C <sub>L</sub> = 30 pF, R <sub>L1</sub> not connected, R <sub>L2</sub> = 1.6 kΩ, See Figure 5	17		ns
t <sub>w(NR)</sub>	Bn	Rn	$\overline{TE}$ at 2 V, $\overline{RE}$ at 0.8 V, V <sub>L</sub> = 0, R <sub>L1</sub> = 390 Ω, R <sub>L2</sub> = 1.6 kΩ, C <sub>L</sub> = 30 pF, See Figure 6	3		ns



# SN75ALS056, SN75ALS057 TRAPEZOIDAL-WAVEFORM INTERFACE BUS TRANSCEIVERS

SLLS028G – AUGUST 1987 – REVISED JUNE 1998

switching characteristics over recommended ranges of supply voltage and operating free-air temperature (unless otherwise noted) (continued)

PARAMETER	FROM (INPUT)	TO (OUTPUT)	TEST CONDITIONS	SN75ALS057 DRIVER PLUS RECEIVER		UNIT
				MIN	MAX	
t <sub>PLH6</sub>	Dn	Rn	$\overline{RE}$ at 0.8 V, $\overline{TE}$ at 0.8 V, R <sub>L1</sub> = 390 Ω, R <sub>L2</sub> = 1.6 kΩ, C <sub>L</sub> = 30 pF, See Figure 7	40		ns
t <sub>PHL6</sub>				40		

## PARAMETER MEASUREMENT INFORMATION

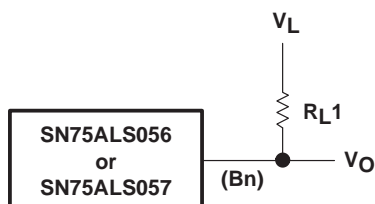
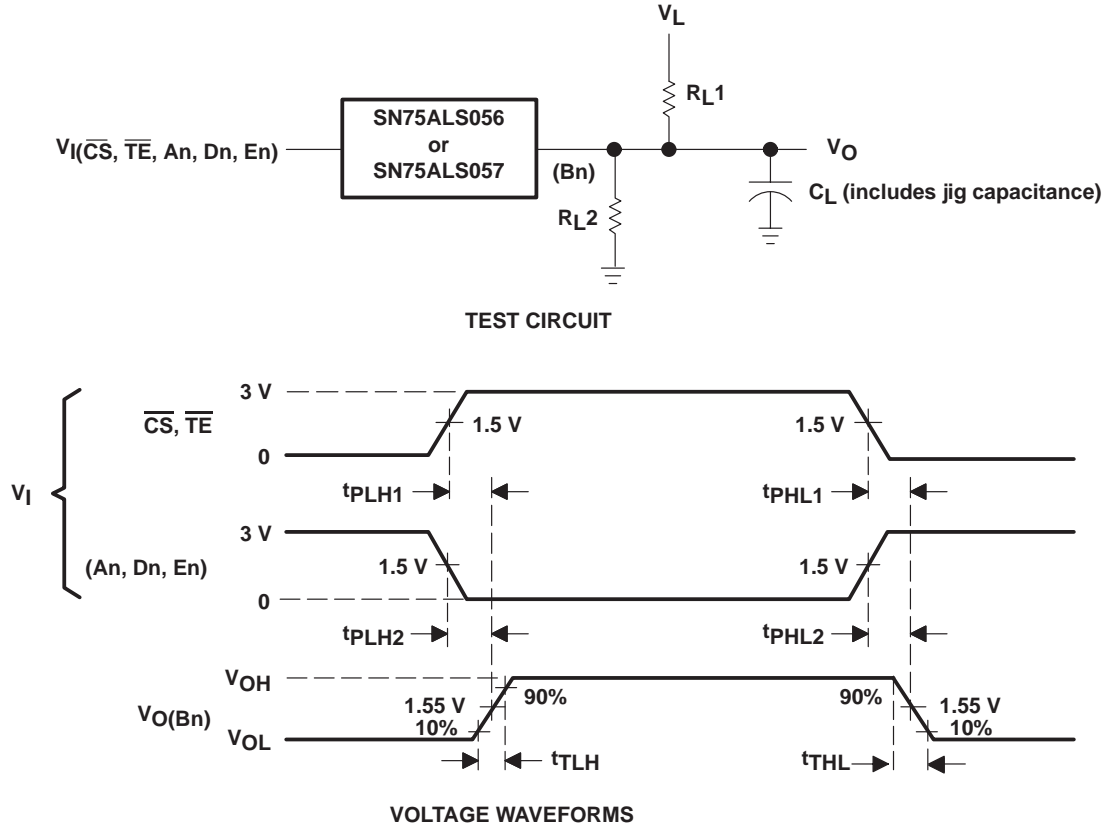

Figure 1. Driver Low-Level-Output-Voltage Test Circuit

# SN75ALS056, SN75ALS057 TRAPEZOIDAL-WAVEFORM INTERFACE BUS TRANSCEIVERS

SLLS028G – AUGUST 1987 – REVISED JUNE 1998

## PARAMETER MEASUREMENT INFORMATION



NOTE A:  $t_r = t_f \leq 5$  ns from 10% to 90%

**Figure 2. Driver Test Circuit and Voltage Waveforms**

# SN75ALS056, SN75ALS057 TRAPEZOIDAL-WAVEFORM INTERFACE BUS TRANSCEIVERS

SLLS028G – AUGUST 1987 – REVISED JUNE 1998

## PARAMETER MEASUREMENT INFORMATION

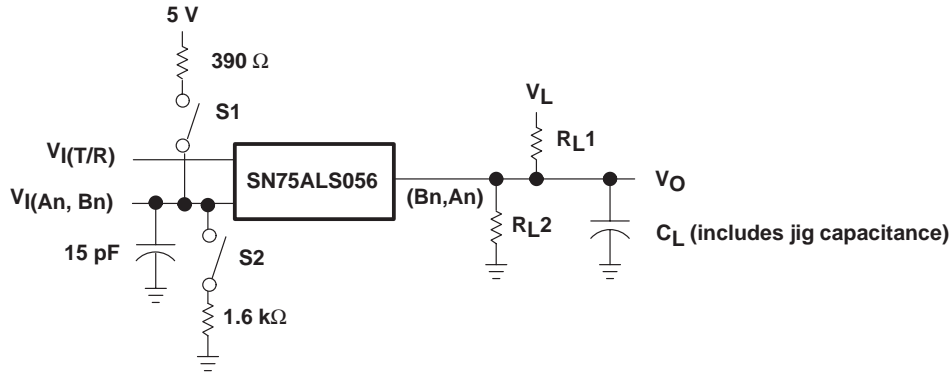

### TEST CIRCUIT

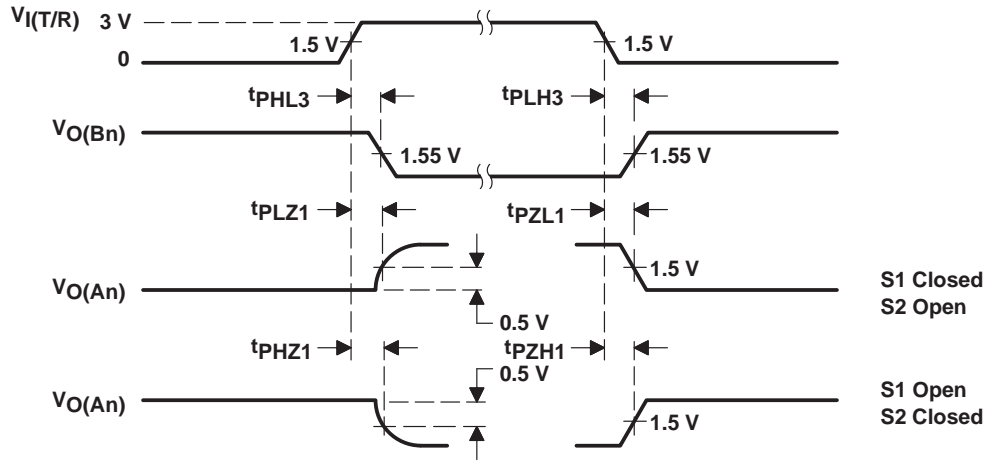

### VOLTAGE WAVEFORMS

NOTE A:  $t_r = t_f \leq 5$  ns from 10% to 90%

Figure 3. Propagation Delay From  $\overline{T/R}$  to An or Bn Test Circuit and Voltage Waveforms

# SN75ALS056, SN75ALS057 TRAPEZOIDAL-WAVEFORM INTERFACE BUS TRANSCEIVERS

SLLS028G – AUGUST 1987 – REVISED JUNE 1998

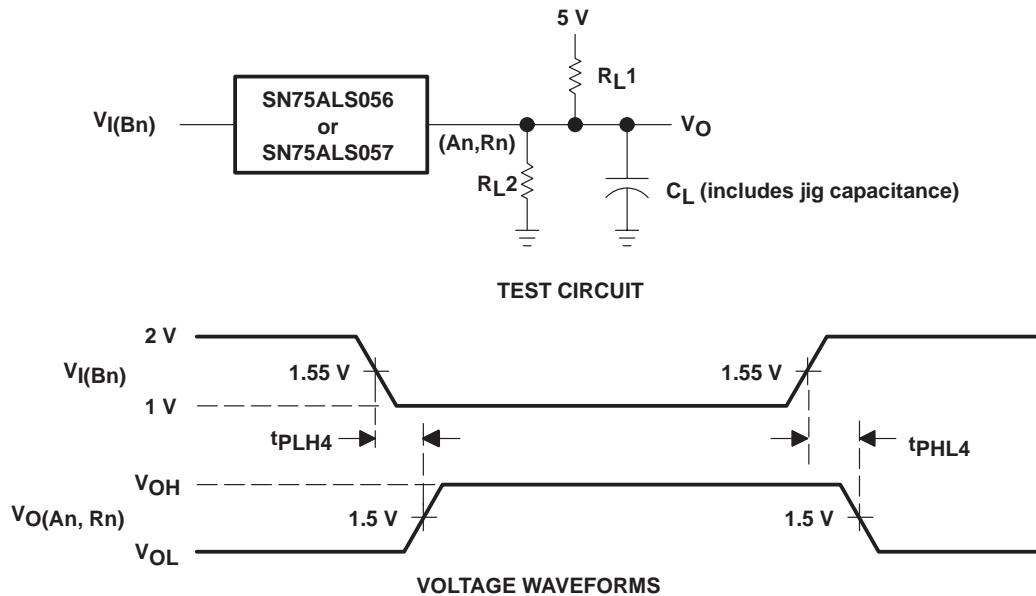

NOTE A:  $t_r = t_f \leq 5$  ns from 10% to 90%

**Figure 4. Receiver Test Circuit and Voltage Waveforms**

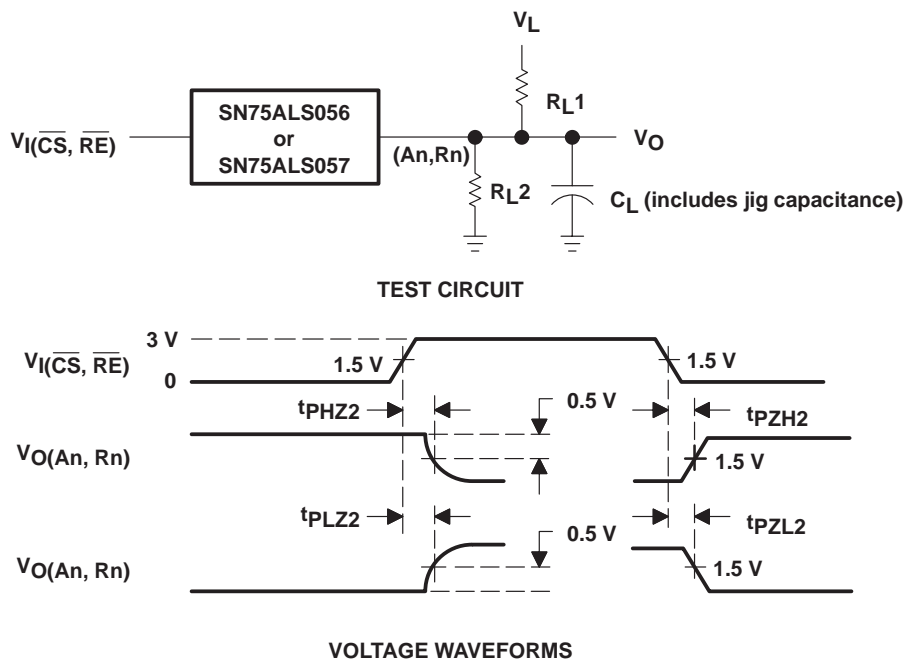

NOTE A:  $t_r = t_f \leq 5$  ns from 10% to 90%

**Figure 5. Propagation Delay From  $\overline{CS}$  to An or  $\overline{RE}$  to Rn Test Circuit and Voltage Waveforms**

# SN75ALS056, SN75ALS057 TRAPEZOIDAL-WAVEFORM INTERFACE BUS TRANSCEIVERS

SLLS028G – AUGUST 1987 – REVISED JUNE 1998

## PARAMETER MEASUREMENT INFORMATION

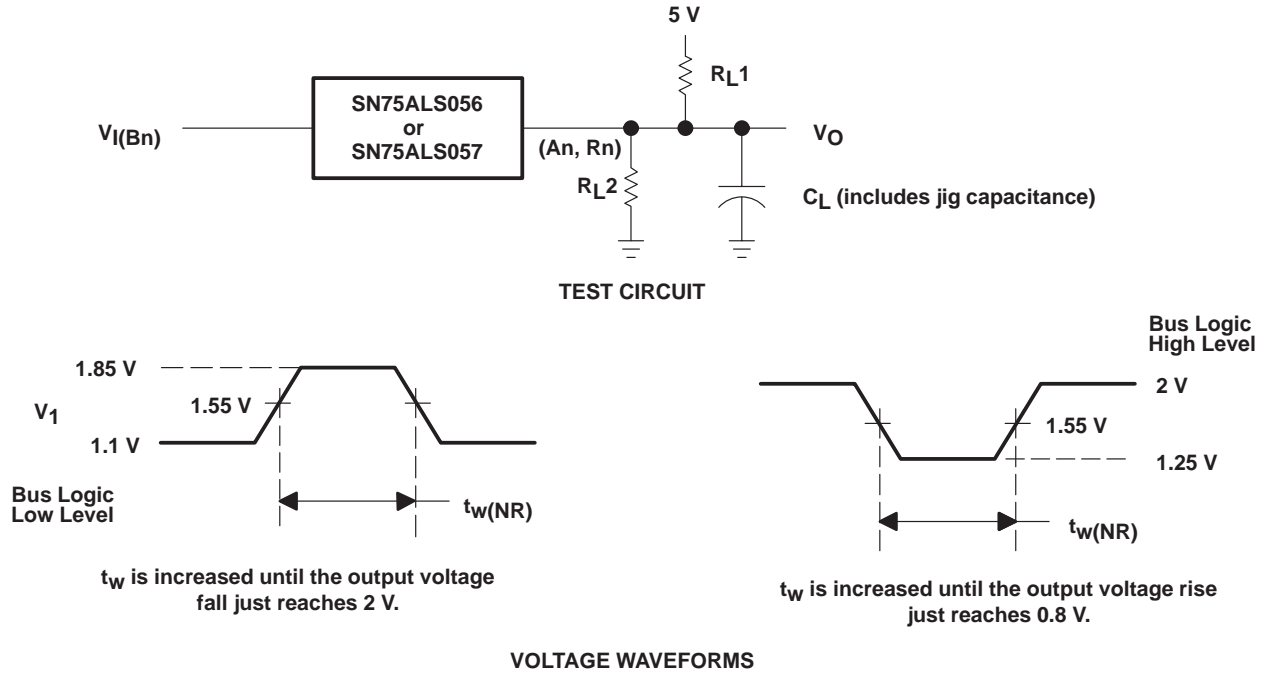

Figure 6. Receiver Noise-Immunity Test Circuit and Voltage Waveforms

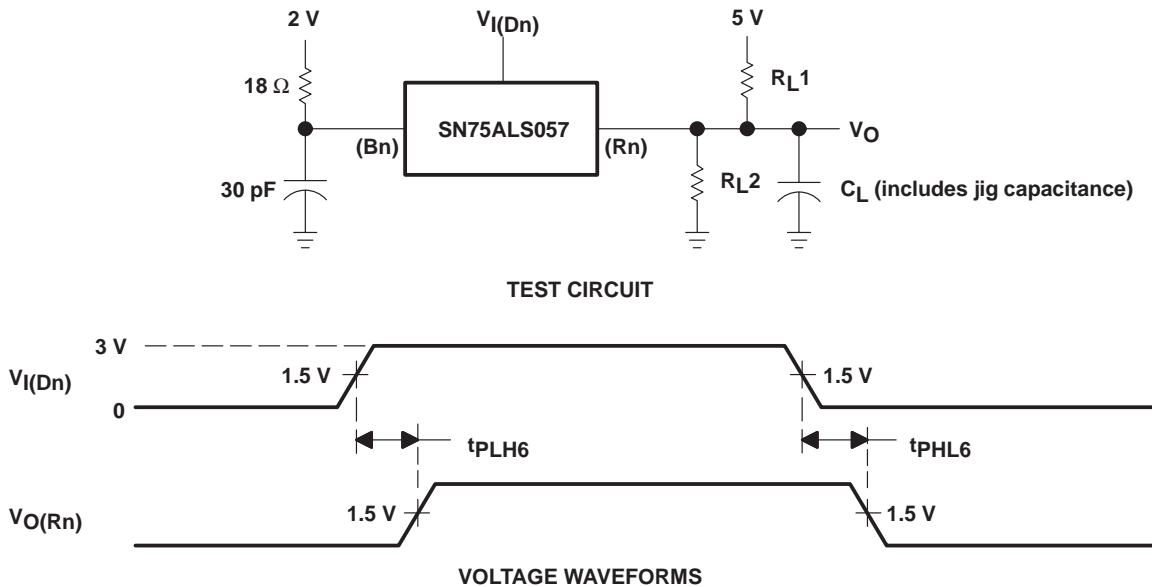

Figure 7. Driver Plus Receiver Delay-Times Test Circuits and Voltage Waveforms

## PACKAGING INFORMATION

Orderable Device	Status (1)	Package Type	Package Drawing	Pins	Package Qty	Eco Plan (2)	Lead finish/ Ball material (6)	MSL Peak Temp (3)	Op Temp (°C)	Device Marking (4/5)	Samples
SN75ALS056DW	ACTIVE	SOIC	DW	20	25	RoHS & Green	NIPDAU	Level-1-260C-UNLIM	0 to 70	75ALS056	<a href="#">Samples</a>
SN75ALS057DW	ACTIVE	SOIC	DW	20	25	RoHS & Green	NIPDAU	Level-1-260C-UNLIM	0 to 70	75ALS057	<a href="#">Samples</a>
SN75ALS057DWR	ACTIVE	SOIC	DW	20	2000	RoHS & Green	NIPDAU	Level-1-260C-UNLIM	0 to 70	75ALS057	<a href="#">Samples</a>

(1) The marketing status values are defined as follows:

**ACTIVE:** Product device recommended for new designs.

**LIFEBUY:** TI has announced that the device will be discontinued, and a lifetime-buy period is in effect.

**NRND:** Not recommended for new designs. Device is in production to support existing customers, but TI does not recommend using this part in a new design.

**PREVIEW:** Device has been announced but is not in production. Samples may or may not be available.

**OBsolete:** TI has discontinued the production of the device.

(2) **RoHS:** TI defines "RoHS" to mean semiconductor products that are compliant with the current EU RoHS requirements for all 10 RoHS substances, including the requirement that RoHS substance do not exceed 0.1% by weight in homogeneous materials. Where designed to be soldered at high temperatures, "RoHS" products are suitable for use in specified lead-free processes. TI may reference these types of products as "Pb-Free".

**RoHS Exempt:** TI defines "RoHS Exempt" to mean products that contain lead but are compliant with EU RoHS pursuant to a specific EU RoHS exemption.

**Green:** TI defines "Green" to mean the content of Chlorine (Cl) and Bromine (Br) based flame retardants meet JS709B low halogen requirements of <=1000ppm threshold. Antimony trioxide based flame retardants must also meet the <=1000ppm threshold requirement.

(3) MSL, Peak Temp. - The Moisture Sensitivity Level rating according to the JEDEC industry standard classifications, and peak solder temperature.

(4) There may be additional marking, which relates to the logo, the lot trace code information, or the environmental category on the device.

(5) Multiple Device Markings will be inside parentheses. Only one Device Marking contained in parentheses and separated by a "~" will appear on a device. If a line is indented then it is a continuation of the previous line and the two combined represent the entire Device Marking for that device.

(6) Lead finish/Ball material - Orderable Devices may have multiple material finish options. Finish options are separated by a vertical ruled line. Lead finish/Ball material values may wrap to two lines if the finish value exceeds the maximum column width.

**Important Information and Disclaimer:**The information provided on this page represents TI's knowledge and belief as of the date that it is provided. TI bases its knowledge and belief on information provided by third parties, and makes no representation or warranty as to the accuracy of such information. Efforts are underway to better integrate information from third parties. TI has taken and continues to take reasonable steps to provide representative and accurate information but may not have conducted destructive testing or chemical analysis on incoming materials and chemicals. TI and TI suppliers consider certain information to be proprietary, and thus CAS numbers and other limited information may not be available for release.

In no event shall TI's liability arising out of such information exceed the total purchase price of the TI part(s) at issue in this document sold by TI to Customer on an annual basis.

**TAPE AND REEL INFORMATION**

**QUADRANT ASSIGNMENTS FOR PIN 1 ORIENTATION IN TAPE**

\*All dimensions are nominal

Device	Package Type	Package Drawing	Pins	SPQ	Reel Diameter (mm)	Reel Width W1 (mm)	A0 (mm)	B0 (mm)	K0 (mm)	P1 (mm)	W (mm)	Pin1 Quadrant
SN75ALS057DWR	SOIC	DW	20	2000	330.0	24.4	10.8	13.3	2.7	12.0	24.0	Q1

**TAPE AND REEL BOX DIMENSIONS**

\*All dimensions are nominal

Device	Package Type	Package Drawing	Pins	SPQ	Length (mm)	Width (mm)	Height (mm)
SN75ALS057DWR	SOIC	DW	20	2000	350.0	350.0	43.0

**TUBE**

\*All dimensions are nominal

Device	Package Name	Package Type	Pins	SPQ	L (mm)	W (mm)	T (μm)	B (mm)
SN75ALS056DW	DW	SOIC	20	25	506.98	12.7	4826	6.6
SN75ALS057DW	DW	SOIC	20	25	506.98	12.7	4826	6.6

# DW0020A



# PACKAGE OUTLINE

## SOIC - 2.65 mm max height

SOIC



4220724/A 05/2016

**NOTES:**

1. All linear dimensions are in millimeters. Dimensions in parenthesis are for reference only. Dimensioning and tolerancing per ASME Y14.5M.
2. This drawing is subject to change without notice.
3. This dimension does not include mold flash, protrusions, or gate burrs. Mold flash, protrusions, or gate burrs shall not exceed 0.15 mm per side.
4. This dimension does not include interlead flash. Interlead flash shall not exceed 0.43 mm per side.
5. Reference JEDEC registration MS-013.

# EXAMPLE BOARD LAYOUT

DW0020A

SOIC - 2.65 mm max height

SOIC



LAND PATTERN EXAMPLE  
SCALE:6X



SOLDER MASK DETAILS

4220724/A 05/2016

NOTES: (continued)

- 6. Publication IPC-7351 may have alternate designs.
- 7. Solder mask tolerances between and around signal pads can vary based on board fabrication site.

# EXAMPLE STENCIL DESIGN

DW0020A

SOIC - 2.65 mm max height

SOIC



SOLDER PASTE EXAMPLE  
BASED ON 0.125 mm THICK STENCIL  
SCALE:6X

4220724/A 05/2016

NOTES: (continued)

8. Laser cutting apertures with trapezoidal walls and rounded corners may offer better paste release. IPC-7525 may have alternate design recommendations.
9. Board assembly site may have different recommendations for stencil design.

## IMPORTANT NOTICE AND DISCLAIMER

TI PROVIDES TECHNICAL AND RELIABILITY DATA (INCLUDING DATA SHEETS), DESIGN RESOURCES (INCLUDING REFERENCE DESIGNS), APPLICATION OR OTHER DESIGN ADVICE, WEB TOOLS, SAFETY INFORMATION, AND OTHER RESOURCES "AS IS" AND WITH ALL FAULTS, AND DISCLAIMS ALL WARRANTIES, EXPRESS AND IMPLIED, INCLUDING WITHOUT LIMITATION ANY IMPLIED WARRANTIES OF MERCHANTABILITY, FITNESS FOR A PARTICULAR PURPOSE OR NON-INFRINGEMENT OF THIRD PARTY INTELLECTUAL PROPERTY RIGHTS.

These resources are intended for skilled developers designing with TI products. You are solely responsible for (1) selecting the appropriate TI products for your application, (2) designing, validating and testing your application, and (3) ensuring your application meets applicable standards, and any other safety, security, regulatory or other requirements.

These resources are subject to change without notice. TI grants you permission to use these resources only for development of an application that uses the TI products described in the resource. Other reproduction and display of these resources is prohibited. No license is granted to any other TI intellectual property right or to any third party intellectual property right. TI disclaims responsibility for, and you will fully indemnify TI and its representatives against, any claims, damages, costs, losses, and liabilities arising out of your use of these resources.

TI's products are provided subject to [TI's Terms of Sale](#) or other applicable terms available either on [ti.com](http://ti.com) or provided in conjunction with such TI products. TI's provision of these resources does not expand or otherwise alter TI's applicable warranties or warranty disclaimers for TI products.

TI objects to and rejects any additional or different terms you may have proposed.

Mailing Address: Texas Instruments, Post Office Box 655303, Dallas, Texas 75265  
Copyright © 2022, Texas Instruments Incorporated