

DUAL-OUTPUT LOW-DROPOUT VOLTAGE REGULATOR WITH POWER-UP SEQUENCING FOR SPLIT-VOLTAGE DSP SYSTEMS

Check for Samples: [TPS70175-Q1](#)

FEATURES

- Qualified for Automotive Applications
- Dual Output Voltages for Split-Supply Applications
- Selectable Power-Up Sequencing for DSP Applications
- Output Current Range of 500 mA on Regulator 1 and 250 mA on Regulator 2
- Fast Transient Response
- Voltage Options: 5 V/2.5 V
- Open Drain Power-On Reset With 30-ms Delay
- Open Drain Power Good for Regulator 1
- Ultra Low 190- μ A (Typ) Quiescent Current
- 1- μ A Input Current During Standby
- Low Noise = 65 μ V_{RMS} Without a Bypass Capacitor
- Quick Output Capacitor Discharge Feature
- Two Manual Reset Inputs
- 2% Accuracy Over Load and Temperature
- Undervoltage Lockout (UVLO) Feature
- 20-Pin PowerPAD™ TSSOP Package
- Thermal Shutdown Protection

DESCRIPTION

The TPS70175 is designed to provide a complete power management solution for the TMS320™ DSP family, processor power, ASIC, FPGA, and digital applications where dual output voltage regulators are required. Easy programmability of the sequencing function makes the TPS70175 ideal for any TMS320 DSP applications with power sequencing requirements. Differentiated features, such as accuracy, fast transient response, SVS supervisory circuit, manual reset inputs, and an enable function, provide a complete system solution.

The TPS70175 voltage regulator offers low dropout voltage and dual outputs with power-up sequence control, which is designed primarily for DSP applications. These devices have extremely low noise output performance without using any added filter bypass capacitors and are designed to have a fast transient response and be stable with 10- μ F low ESR capacitors.

This device has a fixed 5 V/2.5 V voltage option. Regulator 1 can support up to 500 mA and regulator 2 can support up to 250 mA. Separate voltage inputs allow the designer to configure the source power.

**PWP PACKAGE
(TOP VIEW)**

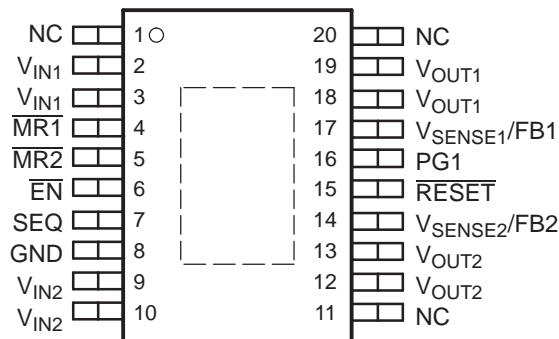

Please be aware that an important notice concerning availability, standard warranty, and use in critical applications of Texas Instruments semiconductor products and disclaimers thereto appears at the end of this data sheet.

PowerPAD, TMS320 are trademarks of Texas Instruments.

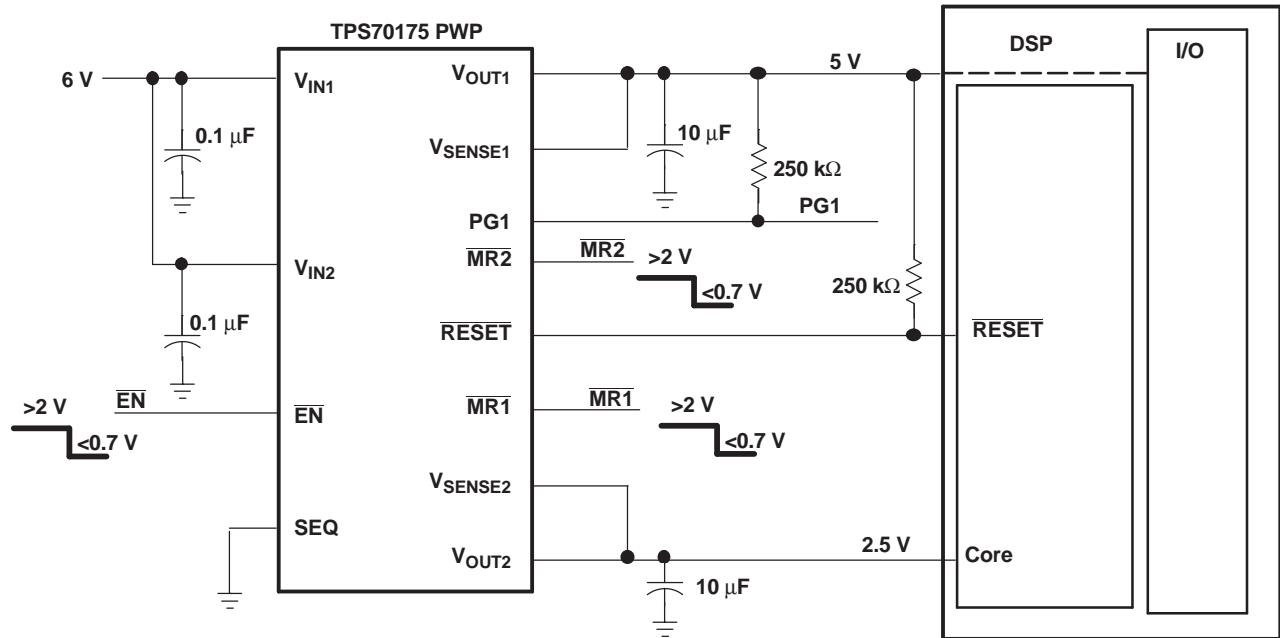

Because the PMOS device behaves as a low-value resistor, the dropout voltage is very low (typically 170 mV on regulator 1) and is directly proportional to the output current. Additionally, since the PMOS pass element is a voltage-driven device, the quiescent current is very low and independent of output loading (maximum of 280 μA over the full range of output current). This LDO family also features a sleep mode; applying a high signal to $\overline{\text{EN}}$ (enable) shuts down both regulators, reducing the input current to 1 μA at $T_J = 25^\circ\text{C}$.

The device is enabled when the $\overline{\text{EN}}$ pin is connected to a low-level input voltage. The output voltages of the two regulators are sensed at the V_{SENSE1} and V_{SENSE2} pins, respectively.

The input signal at the SEQ pin controls the power-up sequence of the two regulators. When the device is enabled and the SEQ terminal is pulled high or left open, V_{OUT2} turns on first and V_{OUT1} remains off until V_{OUT2} reaches approximately 83% of its regulated output voltage. At that time V_{OUT1} is turned on. If V_{OUT2} is pulled below 83% (for example, an overload condition), V_{OUT1} is turned off. Pulling the SEQ terminal low reverses the power-up order and V_{OUT1} is turned on first. The SEQ pin is connected to an internal pullup current source.

For each regulator, there is an internal discharge transistor to discharge the output capacitor when the regulator is turned off (disabled).

The PG1 pin reports the voltage conditions at V_{OUT1} , which can be used to implement an SVS for the circuitry supplied by regulator 1.

The TPS70175 features a $\overline{\text{RESETE}}$ (SVS, POR, or Power-On Reset). $\overline{\text{RESETE}}$ output initiates a reset in DSP systems and related digital applications in the event of an undervoltage condition. $\overline{\text{RESETE}}$ indicates the status of V_{OUT2} and both manual reset pins (MR1 and MR2). When V_{OUT2} reaches 95% of its regulated voltage and MR1 and MR2 are in the logic high state, RESETE goes to a high impedance state after a 30-ms delay. RESETE goes to the logic low state when the V_{OUT2} regulated output voltage is pulled below 95% (for example, an overload condition) of its regulated voltage. To monitor V_{OUT1} , the PG1 output pin can be connected to MR1 or MR2.

The device has an undervoltage lockout (UVLO) circuit which prevents the internal regulators from turning on until V_{IN1} reaches 2.5 V.



This integrated circuit can be damaged by ESD. Texas Instruments recommends that all integrated circuits be handled with appropriate precautions. Failure to observe proper handling and installation procedures can cause damage.

ESD damage can range from subtle performance degradation to complete device failure. Precision integrated circuits may be more susceptible to damage because very small parametric changes could cause the device not to meet its published specifications.

Table 1. ORDERING INFORMATION⁽¹⁾

T _J	REGULATOR 1 V _O (V)	REGULATOR 2 V _O (V)	TSSOP (PWP) ⁽²⁾
–40°C to 125°C	5 V	2.5 V	TPS70175QPWPRQ1

(1) For the most current package and ordering information, see the Package Option Addendum at the end of this document, or see the TI web site at www.ti.com.

(2) Package drawings, thermal data, and symbolization are available at www.ti.com/packaging.

ABSOLUTE MAXIMUM RATINGS

Over operating free-air temperature range (unless otherwise noted)⁽¹⁾

		UNIT
Input voltage range: V _{IN1} , V _{IN2} ⁽²⁾	–0.3 to +7	V
Voltage range at \overline{EN}	–0.3 to +7	V
Output voltage range (V _{OUT1} , V _{SENSE1})	5.5	V
Output voltage range (V _{OUT2} , V _{SENSE2})	5.5	V
Maximum \overline{RESET} , PG1 voltage	7	V
Maximum $\overline{MR1}$, $\overline{MR2}$, and SEQ voltage	V _{IN1}	V
Peak output current	Internally limited	
Junction temperature range, T _J	–40 to +150	°C
Storage temperature range, T _{stg}	–65 to +150	°C
ESD rating, HBM ⁽³⁾	3 (H2)	kV
ESD rating, CDM ⁽³⁾	1.5 (C5)	kV
ESD rating, MM ⁽³⁾	150 (M2)	V
θ _{JA} ⁽⁴⁾	32.63	°C / W

(1) Stresses beyond those listed under *absolute maximum ratings* may cause permanent damage to the device. These are stress ratings only, and functional operation of the device at these or any other conditions beyond those indicated under *recommended operating conditions* is not implied. Exposure to absolute-maximum-rated conditions for extended periods may affect device reliability.

(2) All voltages are tied to network ground.

(3) ESD Protection Level per AEC Q100 Classification

(4) This parameter is measured with the recommended copper heat sink pattern on a 4-layer PCB, 1-oz copper on a 4-in by 4-in ground layer. For more information, see Texas Instruments technical brief SLMA002.

THERMAL INFORMATION

THERMAL METRIC ⁽¹⁾⁽²⁾		TPS70175-Q1	UNITS
		PWP (20 PINS)	
θ _{JA}	Junction-to-ambient thermal resistance	74.1	°C/W
θ _{JCtop}	Junction-to-case (top) thermal resistance	43.1	
θ _{JB}	Junction-to-board thermal resistance	19.7	
ψ _{JT}	Junction-to-top characterization parameter	2.9	
ψ _{JB}	Junction-to-board characterization parameter	17.3	
θ _{JCbot}	Junction-to-case (bottom) thermal resistance	1.4	

(1) For more information about traditional and new thermal metrics, see the *IC Package Thermal Metrics* application report, SPRA953.

(2) For thermal estimates of this device based on PCB copper area, see the [TI PCB Thermal Calculator](#).

RECOMMENDED OPERATING CONDITIONS

Over operating temperature range (unless otherwise noted)

	MIN	MAX	UNIT
Input voltage, V_I ⁽¹⁾	2.7	6	V
Output current, I_O (regulator 1)	0	500	mA
Output current, I_O (regulator 2)	0	250	mA
Operating junction temperature, T_J	-40	125	°C

(1) To calculate the minimum input voltage for maximum output current, use the following equation: $V_{I(\min)} = V_{O(\max)} + V_{DO(\max \text{ load})}$.

ELECTRICAL CHARACTERISTICS

Over recommended operating junction temperature range ($T_J = -40^\circ\text{C}$ to $+125^\circ\text{C}$), V_{IN1} or $V_{IN2} = V_{OUT(\text{nom})} + 1\text{ V}$, $I_O = 1\text{ mA}$, $\overline{\text{EN}} = 0$, $C_O = 33\text{ }\mu\text{F}$, (unless otherwise noted).

PARAMETER		TEST CONDITIONS		MIN	TYP	MAX	UNIT	
V_O	Output voltage ^{(1), (2)}	2.5-V output	$2.7\text{ V} < V_I < 6\text{ V}$, $T_J = 25^\circ\text{C}$		2.5		V	
			$2.7\text{ V} < V_I < 6\text{ V}$,	2.45	2.55			
	5-V output	$2.7\text{ V} < V_I < 6\text{ V}$,	$T_J = 25^\circ\text{C}$		5			
		$2.7\text{ V} < V_I < 6\text{ V}$,		4.9	5.1			
Quiescent current (GND current) for regulator 1 and regulator 2, $\overline{\text{EN}} = 0\text{ V}$ ⁽¹⁾		See ⁽²⁾	$T_J = 25^\circ\text{C}$		190		μA	
		See ⁽²⁾				280		
Output voltage line regulation for regulator 1 and regulator 2		$5.3\text{ V} < V_{IN} < 6\text{ V}$	V_{OUT1}	4.95		5.05	V	
		$3.5\text{ V} < V_{IN} < 6\text{ V}$	V_{OUT2}	2.475		2.525		
V_n	Output noise voltage	Regulator 1	BW 300 Hz to 50 kHz, $C_O = 33\text{ }\mu\text{F}$, $T_J = 25^\circ\text{C}$		65		μV_{RMS}	
		Regulator 2			65			
Output current limit	Regulator 1	$V_{OUT} = 0\text{ V}$			1.6	2		A
	Regulator 2				0.75	1.1		
Thermal shutdown junction temperature					150		°C	
$I_{I(\text{standby})}$	Standby current	Regulator 1	$T_J = 25^\circ\text{C}$	$\overline{\text{EN}} = V_I$,		1	μA	
				$\overline{\text{EN}} = V_I$		3		
		Regulator 2		$\overline{\text{EN}} = V_I$,	$T_J = 25^\circ\text{C}$		1	μA
				$\overline{\text{EN}} = V_I$			3	
PSRR	Power-supply ripple rejection	$f = 1\text{ kHz}$, $C_O = 33\text{ }\mu\text{F}$,	$T_J = 25^\circ\text{C}$ ⁽¹⁾		60		dB	
RESET Terminal								
Minimum input voltage for valid $\overline{\text{RESET}}$		$I_{\text{RESET}} = 300\text{ }\mu\text{A}$,	$V_{(\text{RESET})} \leq 0.8\text{ V}$		1	1.3	V	
Trip threshold voltage		V_O decreasing			92%	95%	98%	V_{OUT}
Hysteresis voltage		Measured at V_O			0.5%		V_{OUT}	
$t_{(\text{RESET})}$		RESET pulse duration			30	70	ms	
$t_r(\text{RESET})$		Rising edge deglitch			30		μs	
Output low voltage		$V_I = 3.5\text{ V}$,	$I_{O(\text{RESET})} = 1\text{ mA}$		0.15	0.4	V	
Leakage current		$V_{(\text{RESET})} = 6\text{ V}$				1	μA	

(1) Minimum input operating voltage is 2.7 V or $V_{O(\text{typ})} + 1\text{ V}$, whichever is greater. Maximum input voltage = 6 V, minimum output current = 1 mA.

(2) $I_O = 1\text{ mA}$ to 500 mA for Regulator 1 and 1 mA to 250 mA for Regulator 2.

ELECTRICAL CHARACTERISTICS (continued)

Over recommended operating junction temperature range ($T_J = -40^\circ\text{C}$ to $+125^\circ\text{C}$), V_{IN1} or $V_{IN2} = V_{OUT(nom)} + 1\text{ V}$, $I_O = 1\text{ mA}$, $\overline{\text{EN}} = 0$, $C_O = 33\text{ }\mu\text{F}$, (unless otherwise noted).

PARAMETER	TEST CONDITIONS	MIN	TYP	MAX	UNIT
PG1 Terminal					
Minimum input voltage for valid PG1	$I_{(PG1)} = 300\text{ }\mu\text{A}$, $V_{(PG1)} \leq 0.8\text{ V}$		1	1.3	V
Trip threshold voltage	V_O decreasing	92%	95%	98%	V_{OUT}
Hysteresis voltage	Measured at V_O		0.5%		V_{OUT}
$t_{r(PG1)}$	Rising edge deglitch		30		μs
Output low voltage	$V_I = 2.7\text{ V}$, $I_{O(PG1)} = 1\text{ mA}$		0.15	0.4	V
Leakage current	$V_{(PG1)} = 6\text{ V}$			1	μA
EN Terminal					
High level $\overline{\text{EN}}$ input voltage		2			V
Low level $\overline{\text{EN}}$ input voltage				0.7	V
Input current ($\overline{\text{EN}}$)		-1		1	μA
Falling edge deglitch	Measured at V_O		140		μs
SEQ Terminal					
High level SEQ input voltage		2			V
Low level SEQ input voltage				0.7	V
Falling edge deglitch	Measured at V_O		140		μs
SEQ pullup current source			6		μA
MR1 / MR2 Terminals					
High level input voltage		2			V
Low level input voltage				0.7	V
Falling edge deglitch	Measured at V_O		140		μs
Pullup current source			6		μA
V_{OUT2} Terminal					
V_{OUT2} UV comparator: Positive-going input threshold voltage of V_{OUT2} UV comparator		80% V_O	83% V_O	86% V_O	V
V_{OUT2} UV comparator: Hysteresis			0.5% V_O		mV
V_{OUT2} UV comparator: Falling edge deglitch	V_{SENSE_2} decreasing below threshold		140		μs
Peak output current	2-ms pulse width		375		mA
Discharge transistor current	$V_{OUT2} = 1.5\text{ V}$		7.5		mA
V_{OUT1} Terminal					
V_{OUT1} UV comparator: Positive-going input threshold voltage of V_{OUT1} UV comparator		80% V_O	83% V_O	86% V_O	V
V_{OUT1} UV comparator: Hysteresis			0.5% V_O		mV
V_{OUT1} UV comparator: Falling edge deglitch	V_{SENSE_1} decreasing below threshold		140		μs
Dropout voltage ⁽³⁾	$I_O = 500\text{ mA}$, $T_J = 25^\circ\text{C}$		170		mV
Dropout voltage ⁽³⁾	$I_O = 500\text{ mA}$			275	mV
Peak output current ⁽³⁾	2-ms pulse width		750		mA
Discharge transistor current	$V_{OUT1} = 1.5\text{ V}$		7.5		mA
UVLO threshold		2.4		2.65	V

(3) Input voltage (V_{IN1} or V_{IN2}) = $V_{O(typ)} - 100\text{ mV}$. For 2.5-V regulators, the dropout voltage is limited by input voltage range.

DEVICE INFORMATION

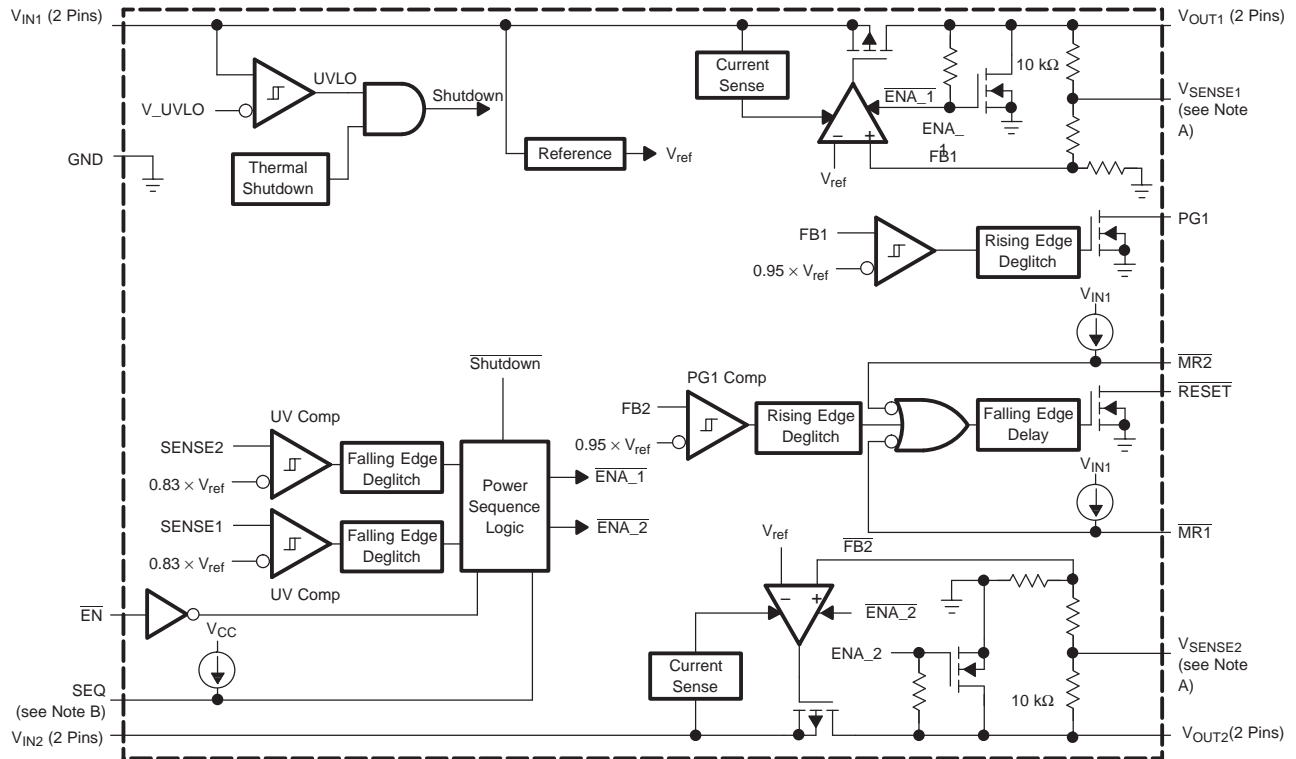

- A. For most applications, V_{SENSE1} and V_{SENSE2} should be externally connected to V_{OUT} as close as possible to the device. For other implementations, refer to SENSE terminal connection discussion in the *Application Information* section.
- B. If the SEQ terminal is floating at the input, V_{OUT2} powers up first.

RESET Timing Diagram (With V_{IN1} Powered Up)

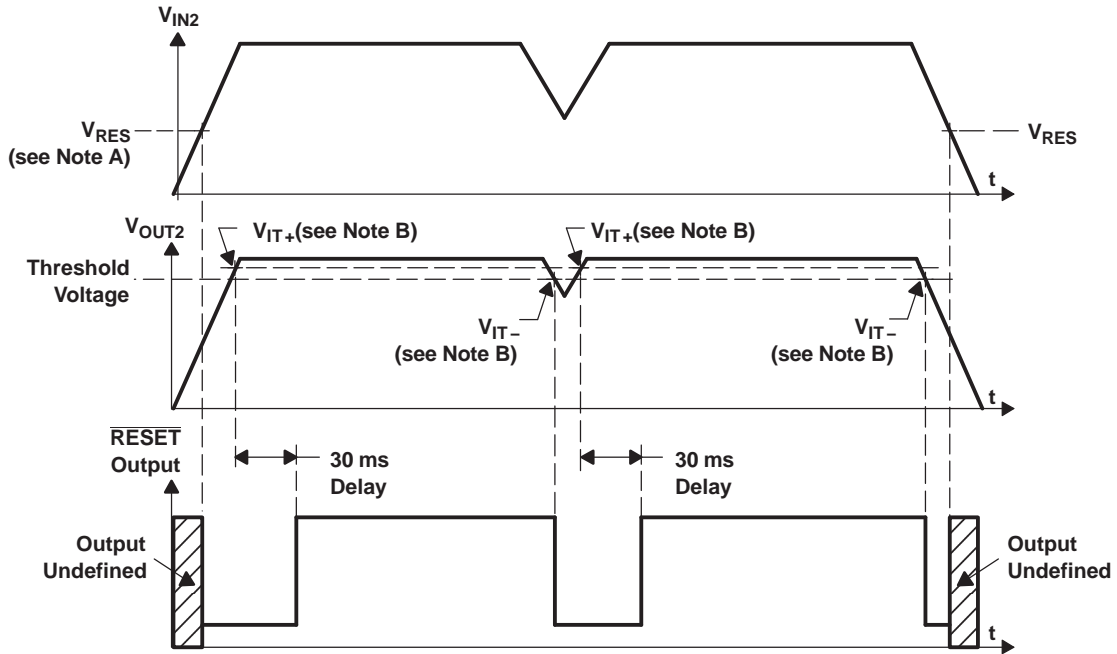

- NOTES: A. V_{RES} is the minimum input voltage for a valid \overline{RESET} . The symbol V_{RES} is not currently listed within EIA or JEDEC standards for semiconductor symbology.
 B. V_{IT-} Trip voltage is typically 5% lower than the output voltage ($95\%V_O$) V_{IT-} to V_{IT+} is the hysteresis voltage.

PG1 Timing Diagram

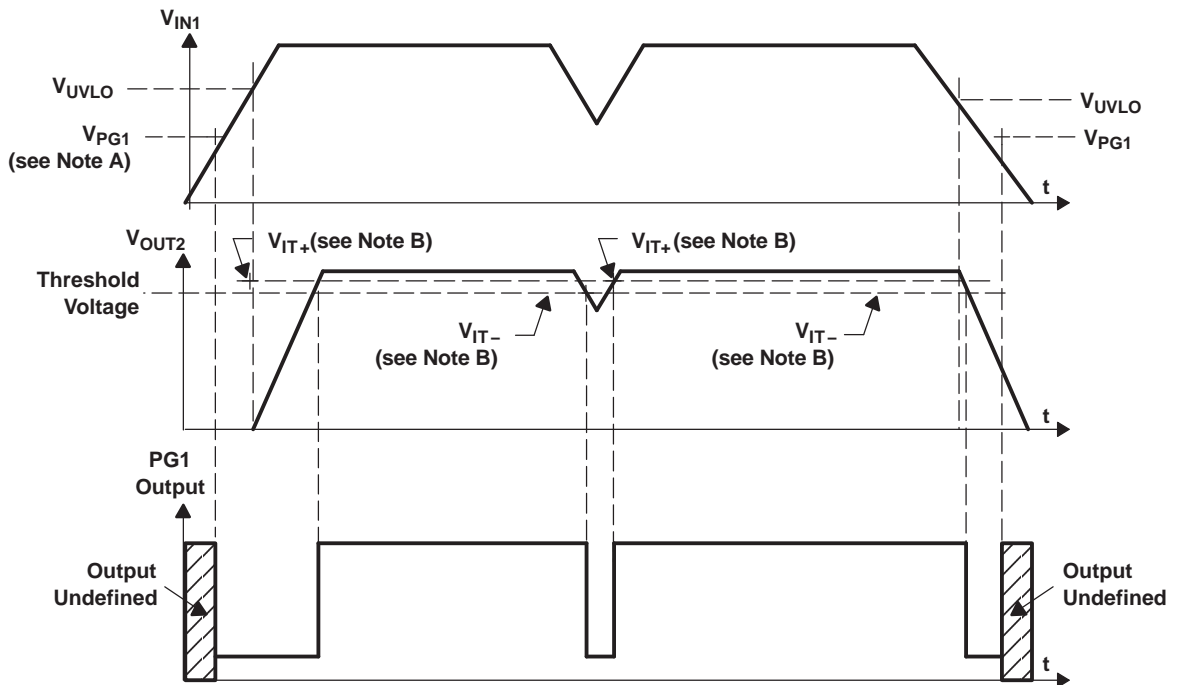

- NOTES: A. V_{PG1} is the minimum input voltage for a valid PG1. The symbol V_{PG1} is not currently listed within EIA or JEDEC standards for semiconductor symbology.
 B. V_{IT-} Trip voltage is typically 5% lower than the output voltage ($95\%V_O$) V_{IT-} to V_{IT+} is the hysteresis voltage.

Table 2. TERMINAL FUNCTIONS

TERMINAL		I/O	DESCRIPTION
NAME	NO.		
$\overline{\text{EN}}$	6	I	Active low enable
GND	8	—	Ground
MR1	4	I	Manual reset input 1, active low, pulled up internally
$\overline{\text{MR2}}$	5	I	Manual reset input 2, active low, pulled up internally
NC	1, 11, 20	—	No connection
PG1	16	O	Open drain output, low when V_{OUT1} voltage is less than 95% of the nominal regulated voltage
RESET	15	O	Open drain output, SVS (power-on reset) signal, active low
SEQ	7	I	Power-up sequence control: SEQ = High, V_{OUT2} powers up first; SEQ = Low, V_{OUT1} powers up first, SEQ terminal pulled up internally.
V_{IN1}	2, 3	I	Input voltage of regulator 1
V_{IN2}	9, 10	I	Input voltage of regulator 2
V_{OUT1}	18, 19	O	Output voltage of regulator 1
V_{OUT2}	12, 13	O	Output voltage of regulator 2
$V_{\text{SENSE2}}/\text{FB2}$	14	I	Regulator 2 output voltage sense
$V_{\text{SENSE1}}/\text{FB1}$	17	I	Regulator 1 output voltage sense

Detailed Description

The TPS70175 low dropout regulator provides dual regulated output voltages for DSP applications which require high performance power management solutions. These devices provide fast transient response and high accuracy with small output capacitors, while drawing low quiescent current. Programmable sequencing provides a power solution for DSPs without any external component requirements. This reduces the component cost and board space while increasing total system reliability. The TPS70175 has an enable feature which puts the device in sleep mode reducing the input currents to less than 3 μA . Other features are integrated SVS (power-on reset, RESET) and power good (PG1) that monitor output voltages and provide logic output to the system. These differentiated features provide a complete DSP power solution.

The TPS70175, unlike many other LDOs, feature low quiescent current, which remains virtually constant even with varying loads. Conventional LDO regulators use a pnp pass element, the base current of which is directly proportional to the load current through the regulator ($I_B = I_C/\beta$). The TPS70175 uses a PMOS transistor to pass current; because the gate of the PMOS is voltage = driven, operating current is low and stable over the full load range.

Pin Functions

Enable

The $\overline{\text{EN}}$ terminal is an input which enables or shuts down the device. If $\overline{\text{EN}}$ is at a voltage high signal, the device is in shutdown mode. When $\overline{\text{EN}}$ goes to voltage low, the device is enabled.

Sequence

The SEQ terminal is an input that programs which output voltage (V_{OUT1} or V_{OUT2}) is turned on first. When the device is enabled and the SEQ terminal is pulled high or left open, V_{OUT2} turns on first and V_{OUT1} remains off until V_{OUT2} reaches approximately 83% of its regulated output voltage. At that time, V_{OUT1} is turned on. If V_{OUT2} is pulled below 83% (for example, an overload condition) V_{OUT1} is turned off. These terminals have a 6- μA pullup current to V_{IN1} .

Pulling the SEQ terminal low reverses the power-up order and V_{OUT1} is turned on first. For detailed timing diagrams, see [Figure 26](#) through [Figure 30](#).

Power-Good

The PG1 is an open drain, active high output terminal which indicates the status of the V_{OUT1} regulator. When the V_{OUT1} reaches 95% of its regulated voltage, PG1 goes to a high impedance state. It goes to a low impedance state when it is pulled below 95% (for example, an overload condition) of its regulated voltage. The open drain output of the PG1 terminal requires a pullup resistor.

Manual Reset Pins ($\overline{MR1}$ and $\overline{MR2}$)

$\overline{MR1}$ and $\overline{MR2}$ are active low input terminals used to trigger a reset condition. When either $\overline{MR1}$ or $\overline{MR2}$ is pulled to logic low, a POR (RESET) occurs. These terminals have a 6- μ A pullup current to V_{IN1} .

Sense (V_{SENSE1} , V_{SENSE2})

The sense terminals of fixed-output options must be connected to the regulator output and the connection should be as short as possible. Internally, sense connects to high-impedance wide-bandwidth amplifiers through a resistor-divider network and noise pickup feeds through to the regulator output. It is essential to route the sense connection in such a way to minimize/avoid noise pickup. Adding RC networks between the V_{SENSE} terminals and V_{OUT} terminals to filter noise is not recommended because it can cause the regulators to oscillate.

RESET Indicator

The TPS70175 features a \overline{RESET} (SVS, POR, or power-on reset). \overline{RESET} can be used to drive power-on reset circuitry or a low-battery indicator. \overline{RESET} is an active low, open drain output which indicates the status of the V_{OUT2} regulator and both manual reset pins ($\overline{MR1}$ and $\overline{MR2}$). When V_{OUT2} exceeds 95% of its regulated voltage and $\overline{MR1}$ and $\overline{MR2}$ are in the high impedance state, \overline{RESET} will go to a high-impedance state after 30-ms delay. \overline{RESET} will go to a low-impedance state when V_{OUT2} is pulled below 95% (for example, an overload condition) of its regulated voltage. To monitor V_{OUT1} , the PG1 output pin can be connected to $\overline{MR1}$ or $\overline{MR2}$. The open drain output of the \overline{RESET} terminal requires a pullup resistor. If \overline{RESET} is not used, it can be left floating.

V_{IN1} and V_{IN2}

V_{IN1} and V_{IN2} are input to the regulators. Internal bias voltages are powered by V_{IN1} .

V_{OUT1} and V_{OUT2}

V_{OUT1} and V_{OUT2} are output terminals of the LDO.

TYPICAL CHARACTERISTICS

Table 3. Table of Graphs

			FIGURE
V_O	Output voltage	vs Output current	1, 2
		vs Temperature	3, 4
	Ground current	vs Junction temperature	5
PSSR	Power-supply rejection ratio	vs Frequency	6–9
Z_O	Output impedance	vs Frequency	10–13
	Dropout voltage	vs Temperature	14
	Load transient response		15, 16
	Equivalent series resistance	vs Output current	17–24
	Test circuit for typical regions of stability performance		25

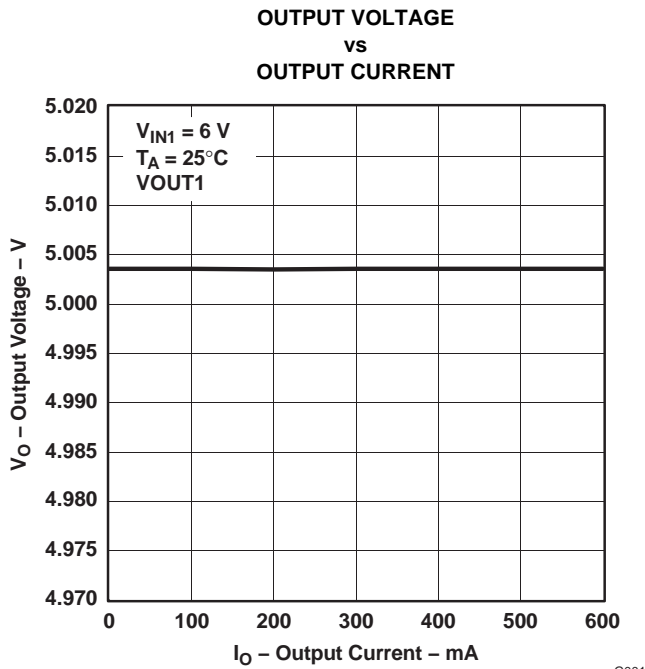

Figure 1.

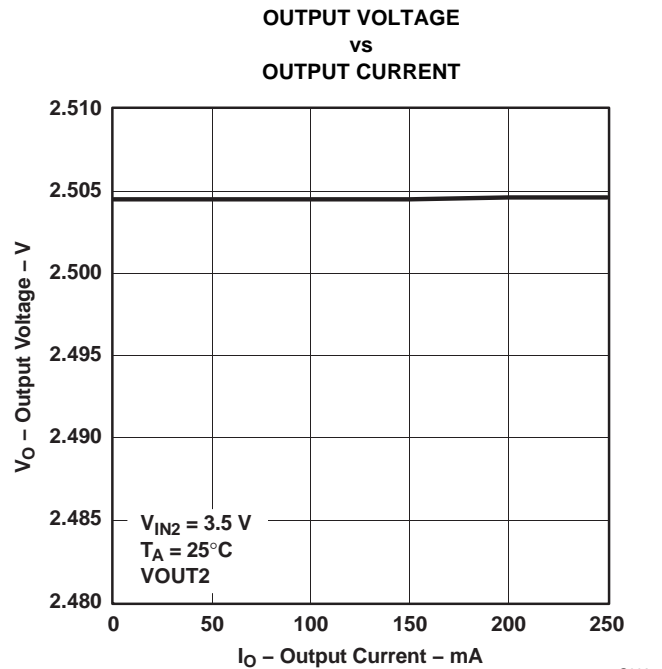

Figure 2.

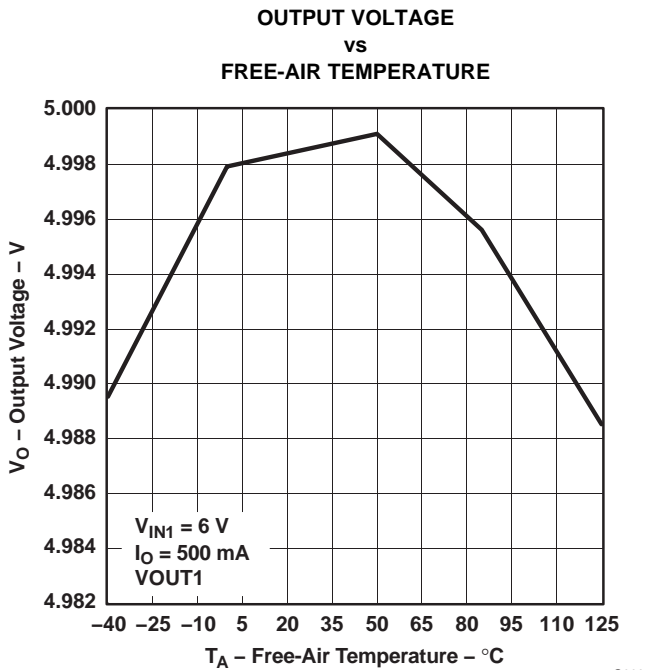

Figure 3.

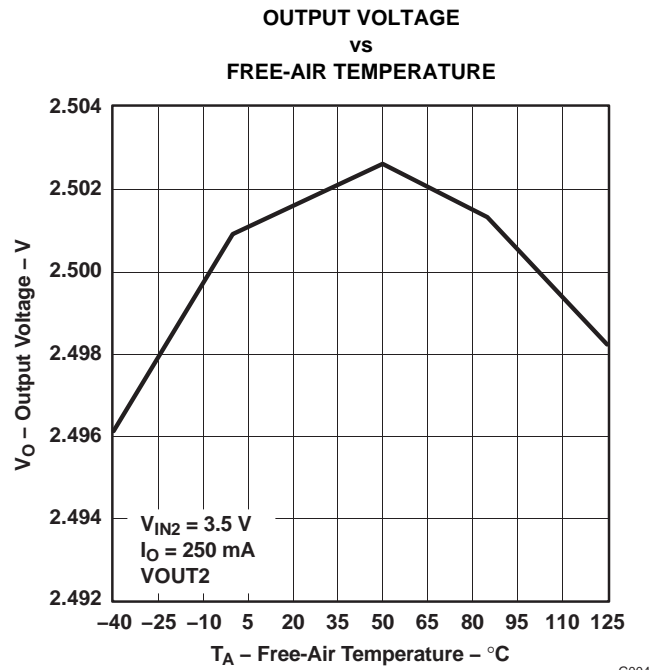

Figure 4.

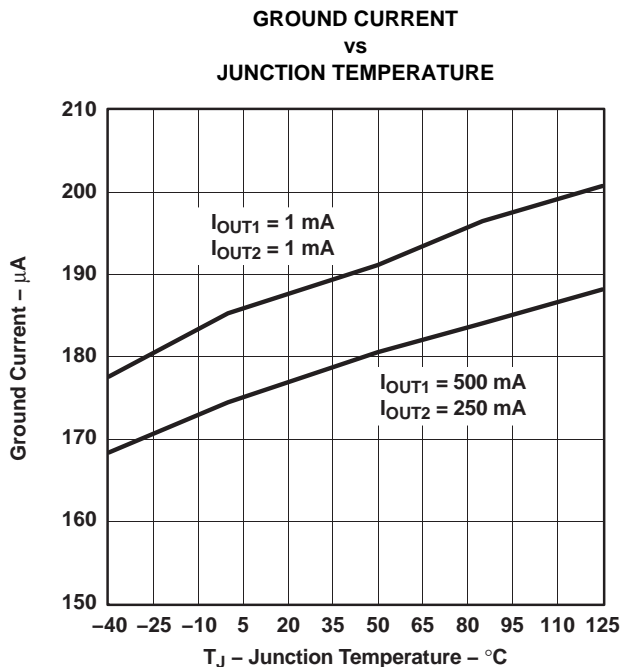

Figure 5.

G005

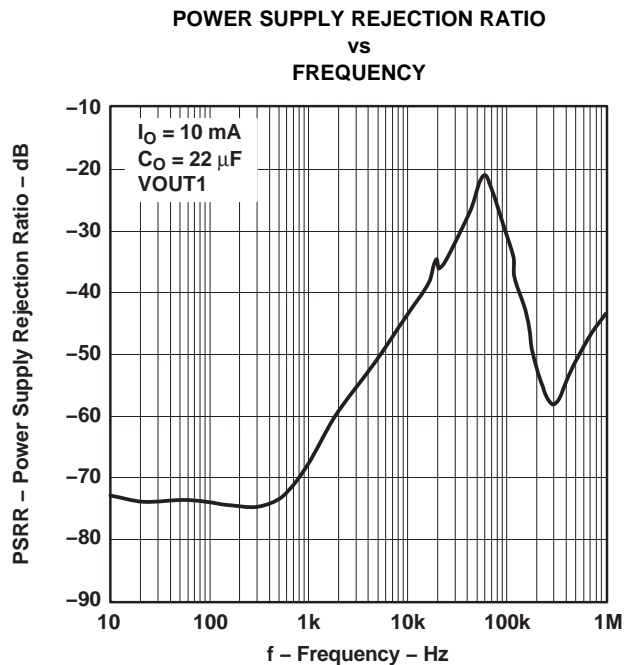

Figure 6.

G006

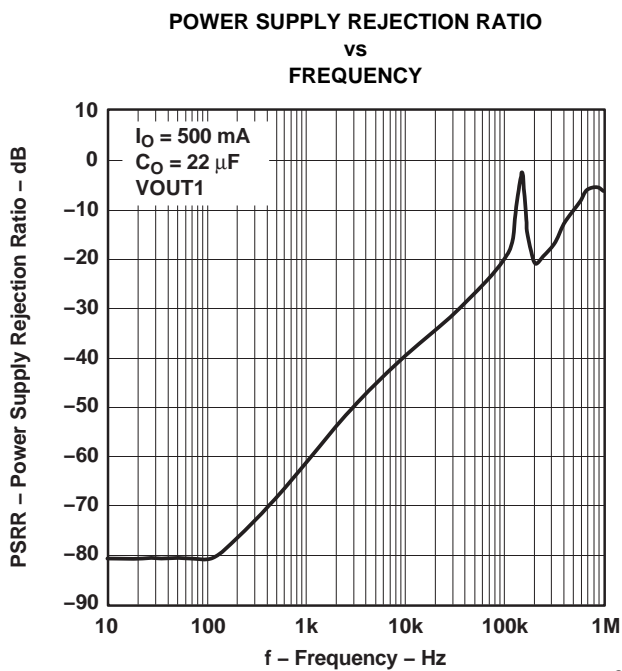

Figure 7.

G007

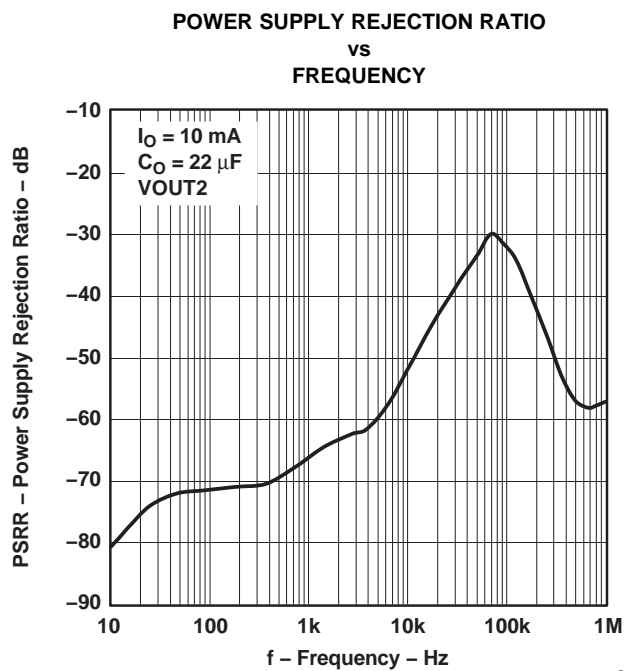

Figure 8.

G008

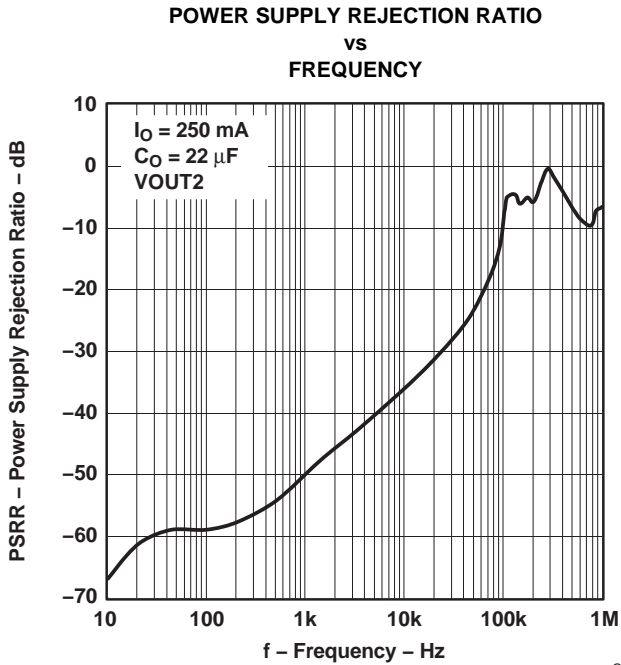

Figure 9.

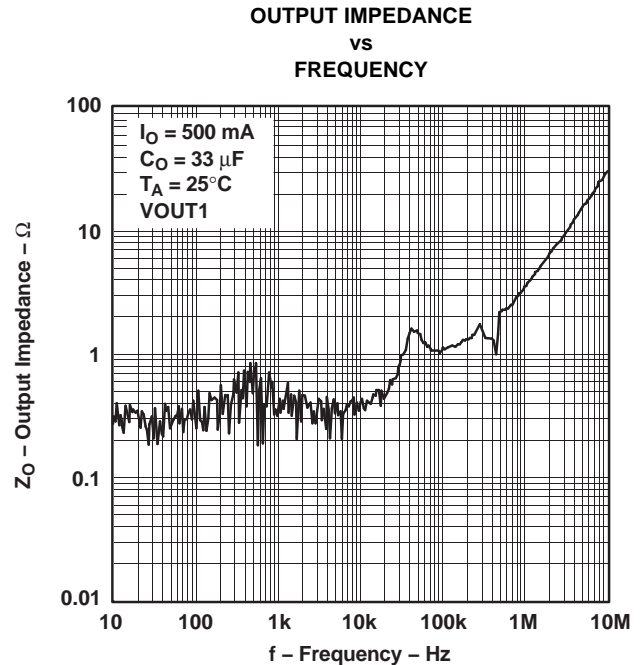

Figure 10.

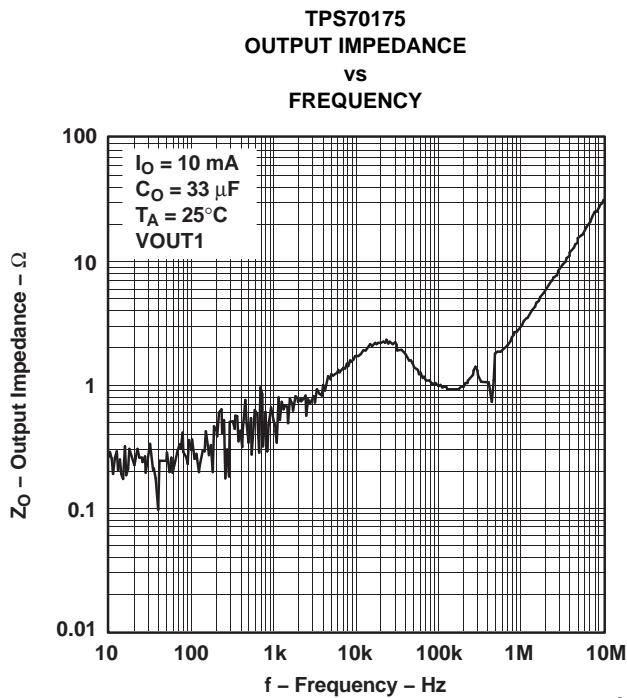

Figure 11.

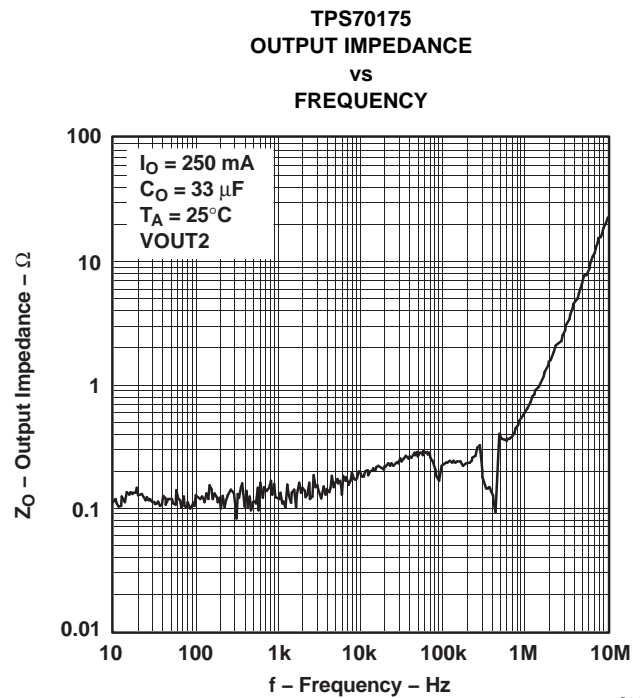

Figure 12.

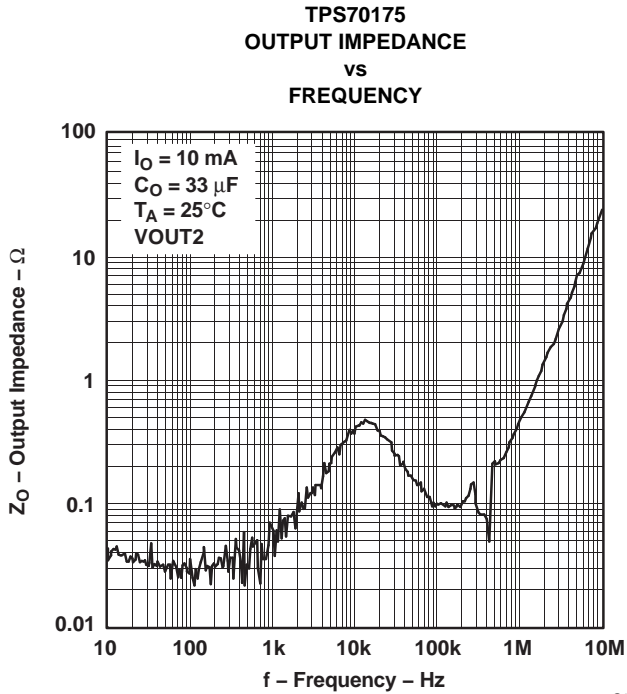

Figure 13.

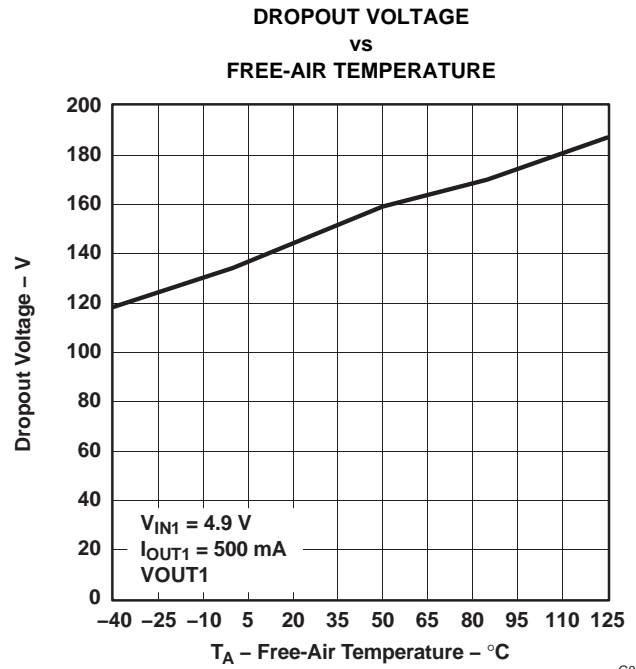

Figure 14.

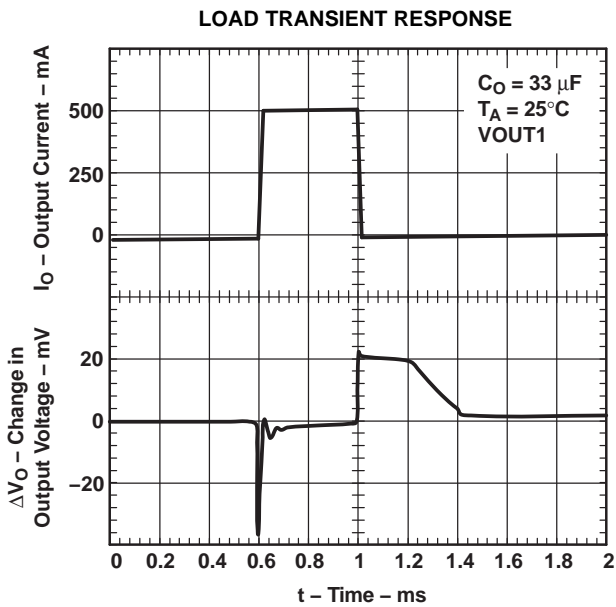

Figure 15.

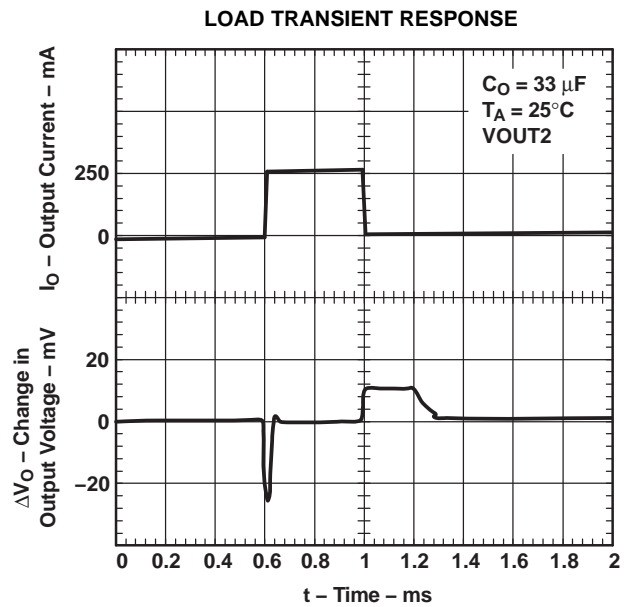

Figure 16.

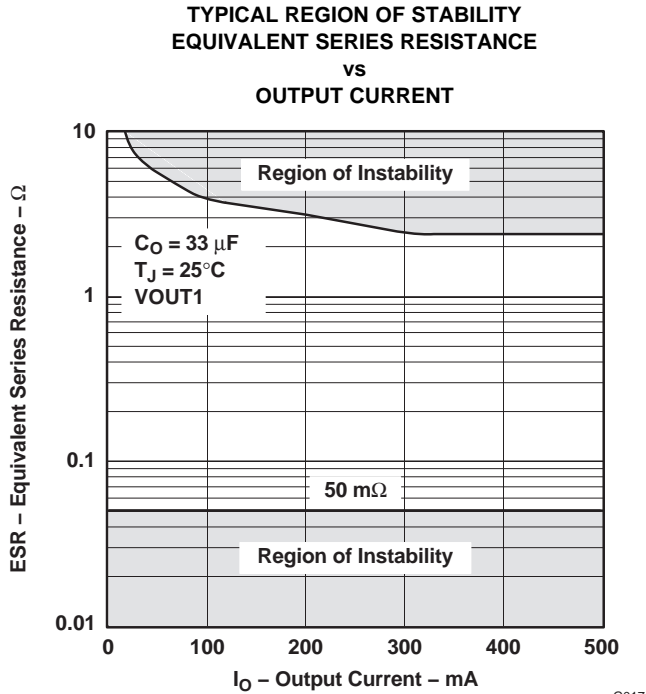

Figure 17.

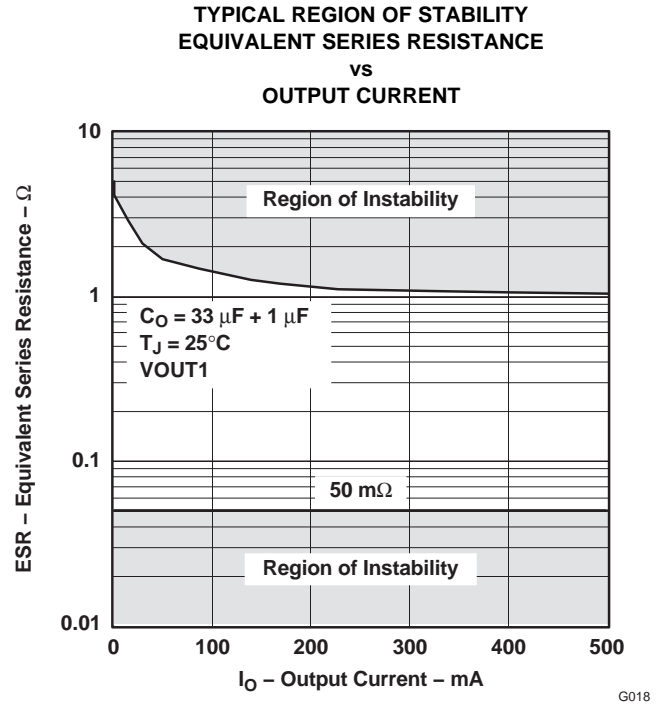

Figure 18.

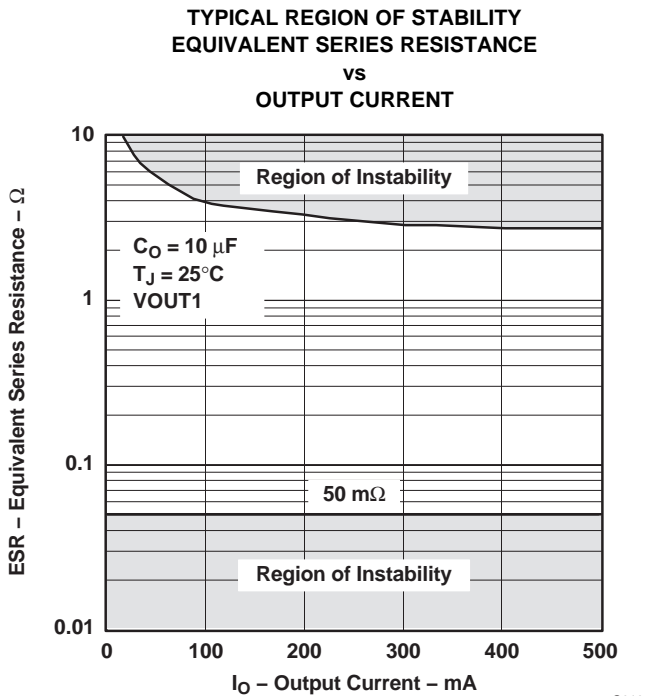

Figure 19.

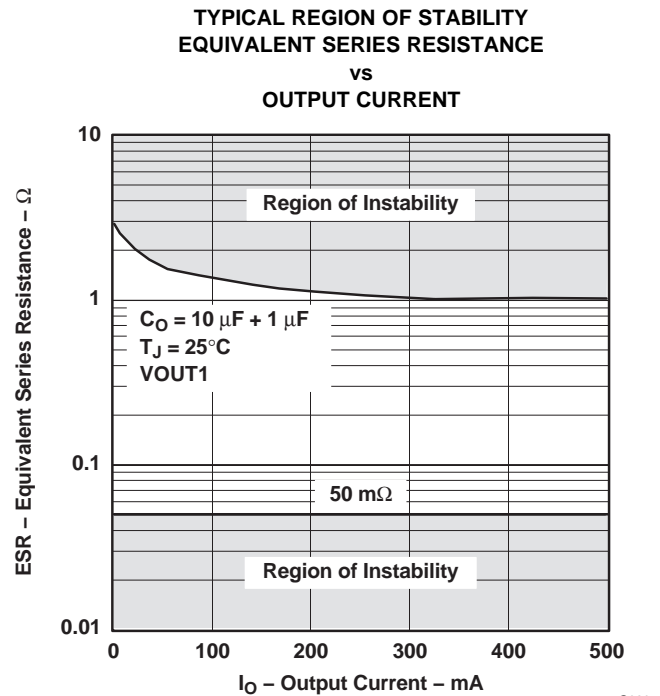

Figure 20.

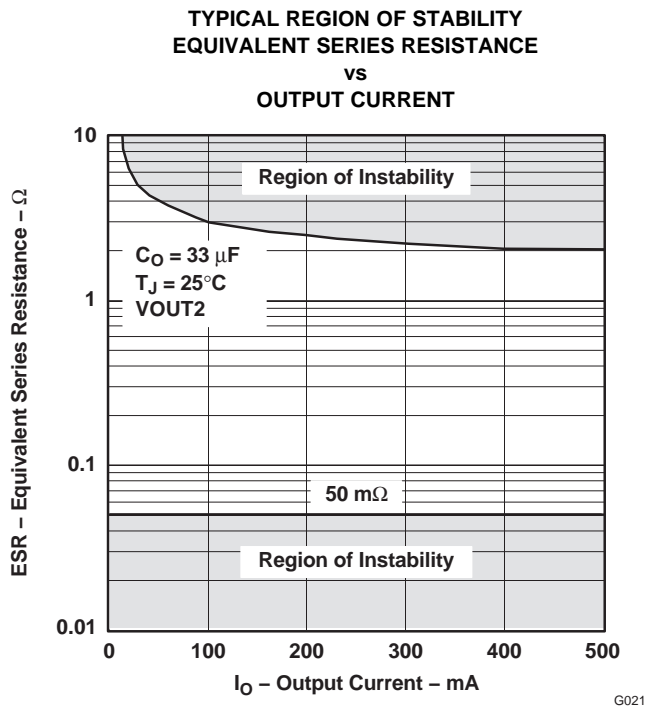

Figure 21.

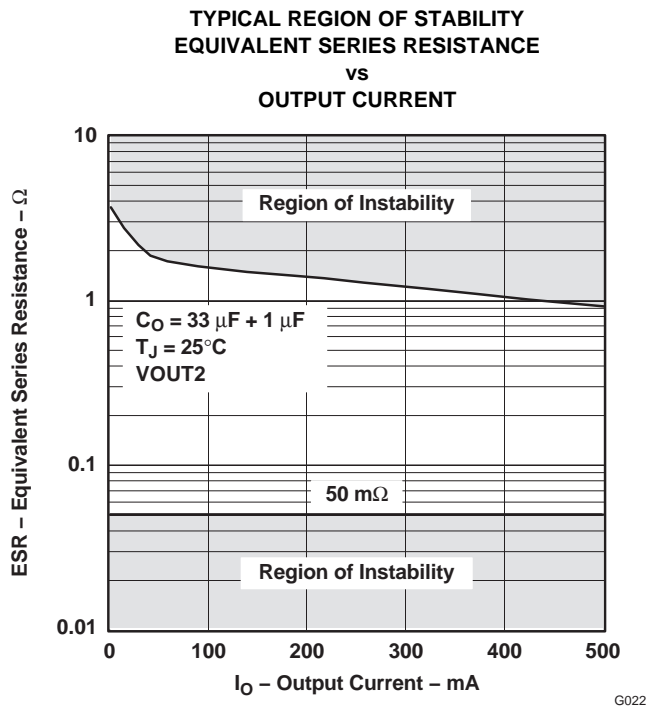

Figure 22.

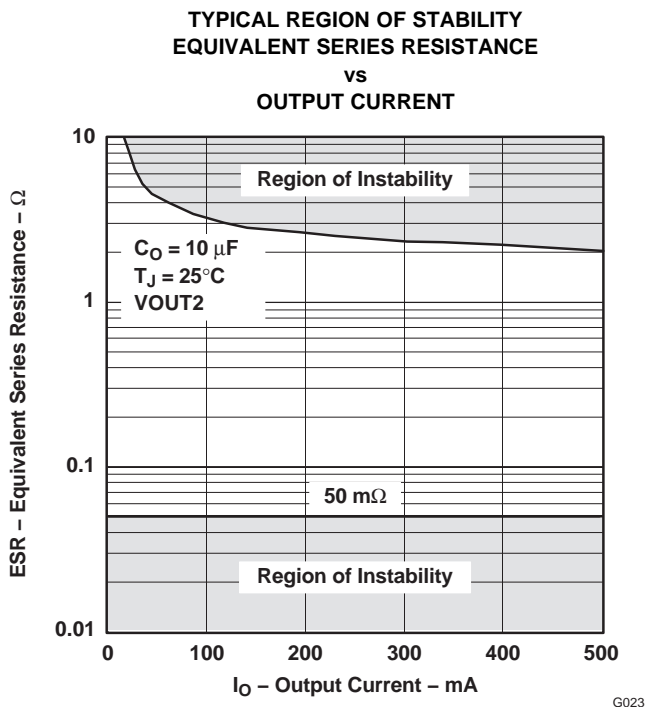

Figure 23.

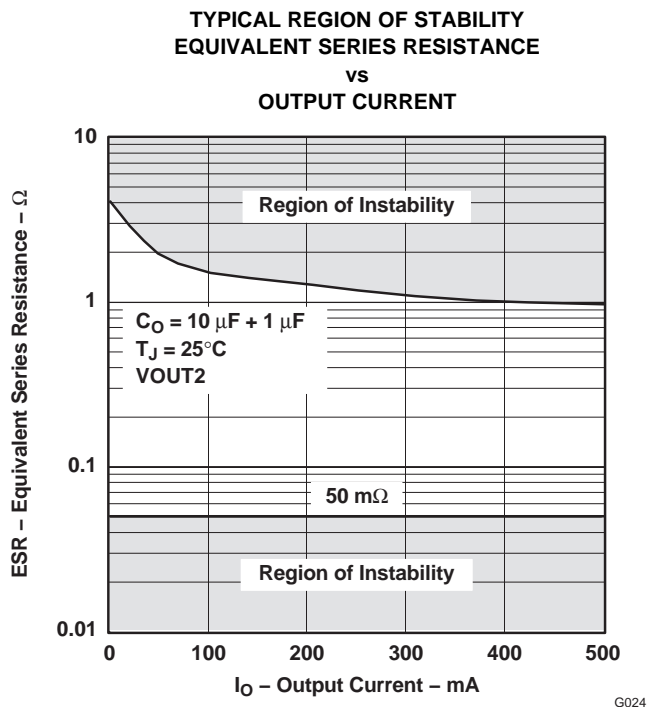

Figure 24.

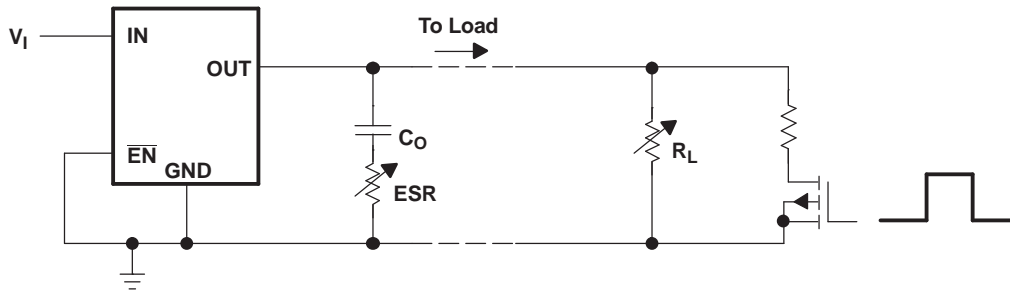

Figure 25. Test Circuit for Typical Regions of Stability

APPLICATION INFORMATION

Sequencing Timing Diagrams

This section provides a number of timing diagrams showing how this device functions in different configurations.

Application condition: $\overline{MR2}$ is tied to PG1, V_{IN1} and V_{IN2} are tied to the same input voltage, the SEQ pin is tied to logic low and the device is toggled with the enable (\overline{EN}) function.

When the device is enabled (\overline{EN} is pulled low), V_{OUT1} turns on first and V_{OUT2} remains off until V_{OUT1} reaches approximately 83% of its regulated output voltage. At that time, V_{OUT2} is turned on. When V_{OUT1} reaches 95% of its regulated output, PG1 turns on (active high). Since $\overline{MR2}$ is connected to PG1 for this application, it follows PG1. When V_{OUT2} reaches 95% of its regulated voltage, \overline{RESET} switches to high voltage level after a 30-ms delay (see Figure 26).

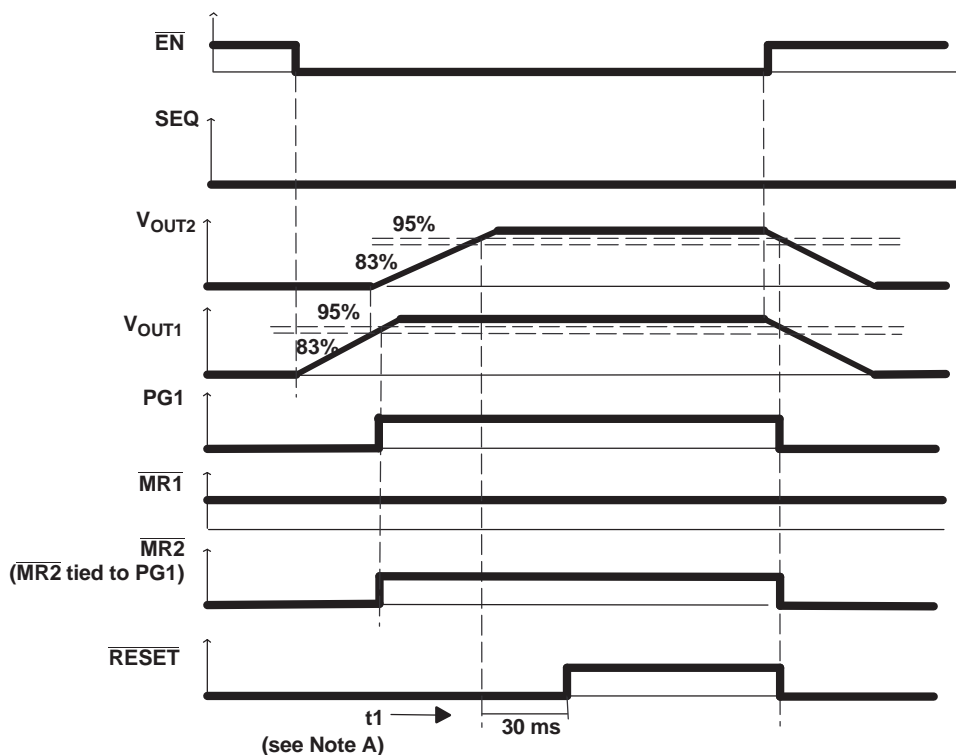
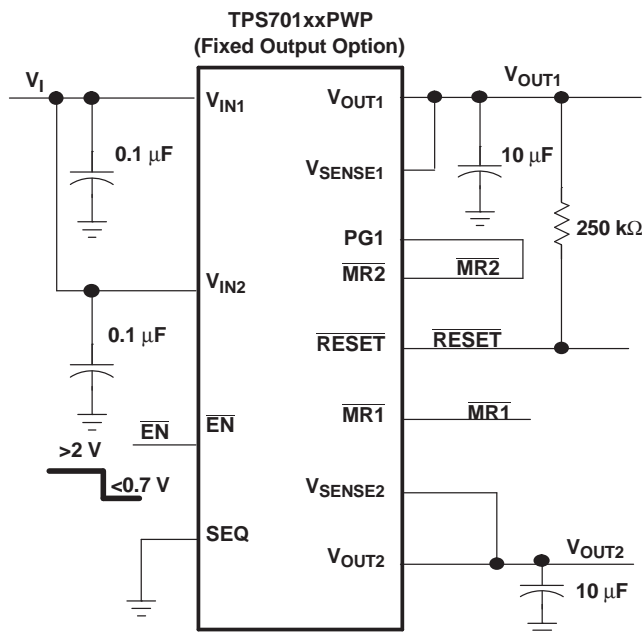

NOTE A: t_1 – Time at which both V_{OUT1} and V_{OUT2} are greater than the PG1 thresholds and $\overline{MR1}$ is logic high.

Figure 26. Timing When SEQ = Low

Application condition: $\overline{\text{MR2}}$ is tied to PG1, V_{IN1} and V_{IN2} are tied to the same input voltage, the SEQ pin is tied to logic high and the device is toggled with the enable ($\overline{\text{EN}}$) function.

When the device is enabled ($\overline{\text{EN}}$ is pulled low), V_{OUT2} begins to power up. When it reaches 83% of its regulated voltage, V_{OUT1} begins to power up. PG1 turns on when V_{OUT1} reaches 95% of its regulated voltage and since $\overline{\text{MR2}}$ and PG1 are tied together, $\overline{\text{MR2}}$ follows PG1. When V_{OUT1} reaches 95% of its regulated voltage, RESET switches to high voltage level after a 30-ms delay (see Figure 27).

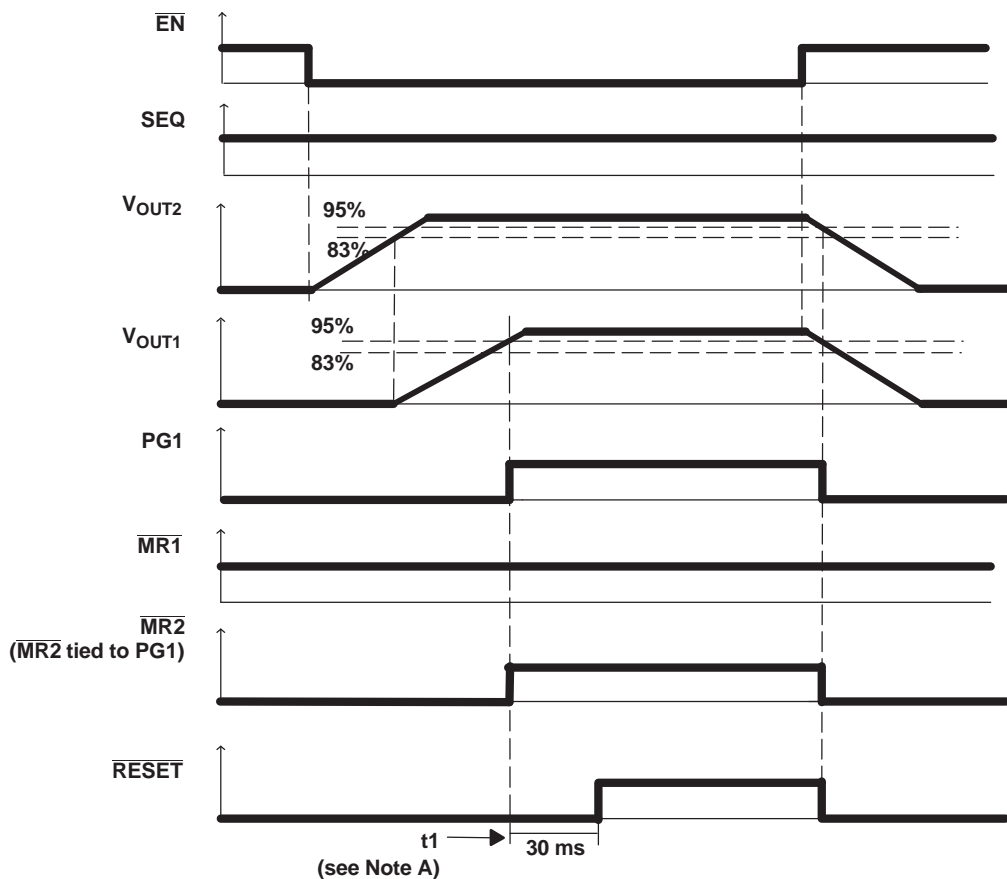
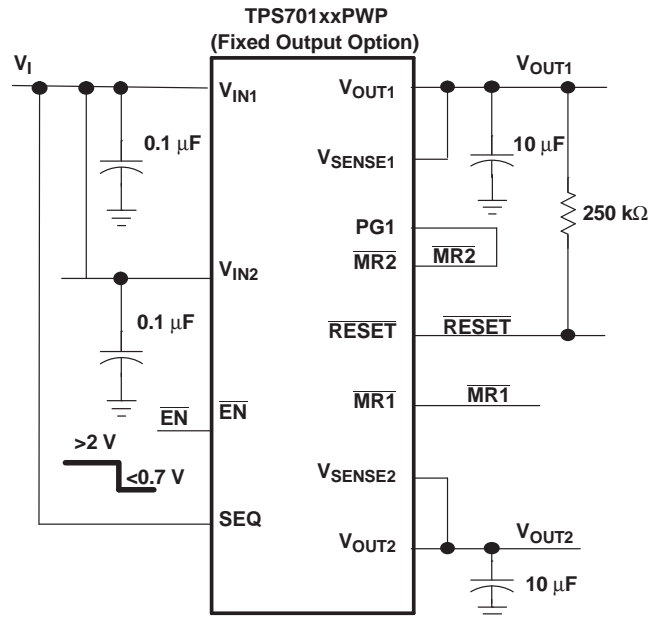

NOTE A: t_1 – Time at which both V_{OUT1} and V_{OUT2} are greater than the PG1 thresholds and $\overline{\text{MR1}}$ is logic high.

Figure 27. Timing When SEQ = High

Application condition: $\overline{\text{MR2}}$ is tied to PG1, V_{IN1} and V_{IN2} are tied to the same input voltage, the SEQ pin is tied to logic high and MR1 is toggled.

When the device is enabled ($\overline{\text{EN}}$ is pulled low), V_{OUT2} begins to power up. When it reaches 83% of its regulated voltage, V_{OUT1} begins to power up. PG1 turns on when V_{OUT1} reaches to 95% of its regulated voltage and since MR2 and PG1 are tied together, MR2 follows PG1. When V_{OUT1} reaches 95% of its regulated voltage, the RESET switches to high after a 30-ms delay. When MR1 is pulled low, it causes RESET to go low, but the regulators remains in regulation (see Figure 28).

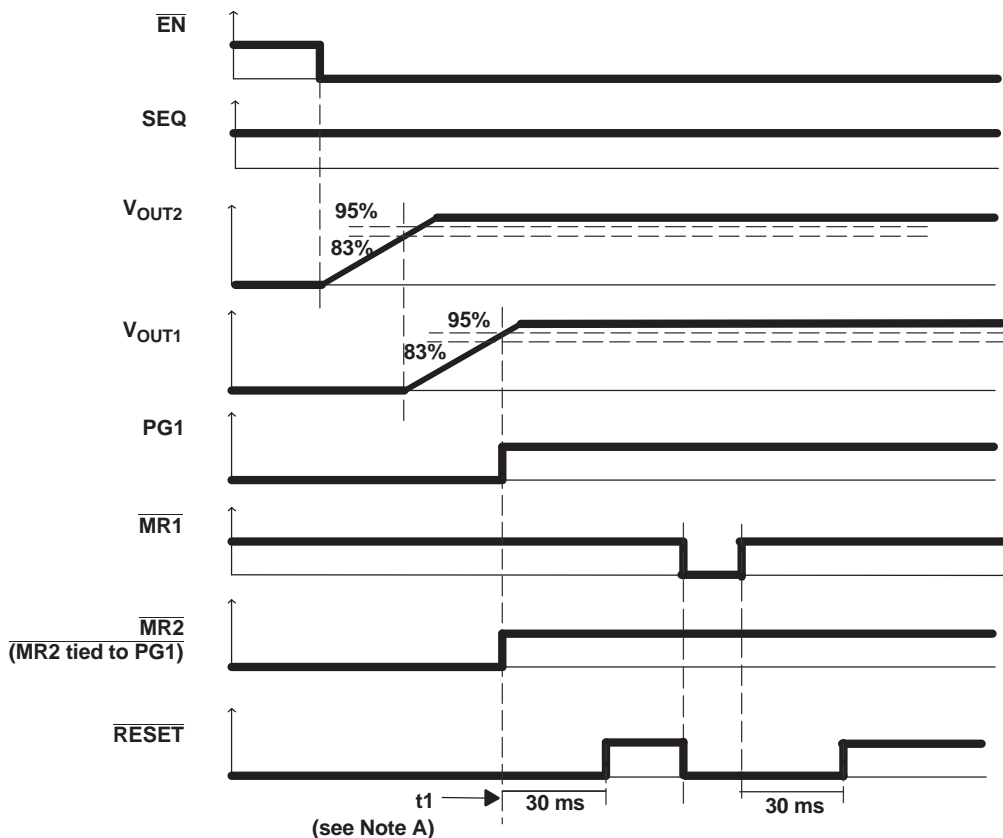
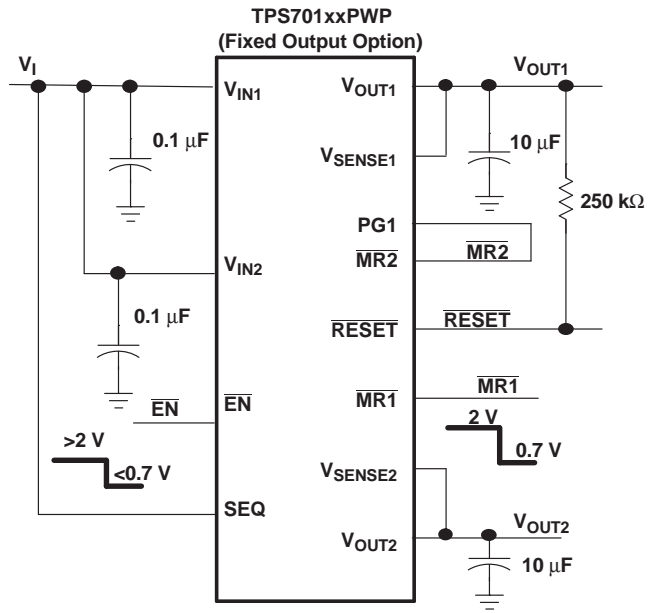

NOTE A: t_1 – Time at which both V_{OUT1} and V_{OUT2} are greater than the PG1 thresholds and $\overline{\text{MR1}}$ is logic high.

Figure 28. Timing When $\overline{\text{MR1}}$ is Toggled

Application condition: $\overline{MR2}$ is tied to PG1, V_{IN1} and V_{IN2} are tied to the same input voltage, the SEQ pin is tied to logic high and V_{OUT1} faults out.

V_{OUT2} begins to power up when the device is enabled (\overline{EN} is pulled low). When V_{OUT2} reaches 83% of its regulated voltage, then V_{OUT1} begins to power up. When V_{OUT1} reaches 95% of its regulated voltage, PG1 turns on and \overline{RESET} switches to high voltage level after a 30-ms delay. When V_{OUT1} faults out, V_{OUT2} remains powered on because the SEQ pin is high. PG1 is tied to $\overline{MR2}$ and both change state to logic low. \overline{RESET} is driven by $\overline{MR2}$ and goes to logic low when V_{OUT1} faults out (see Figure 29).

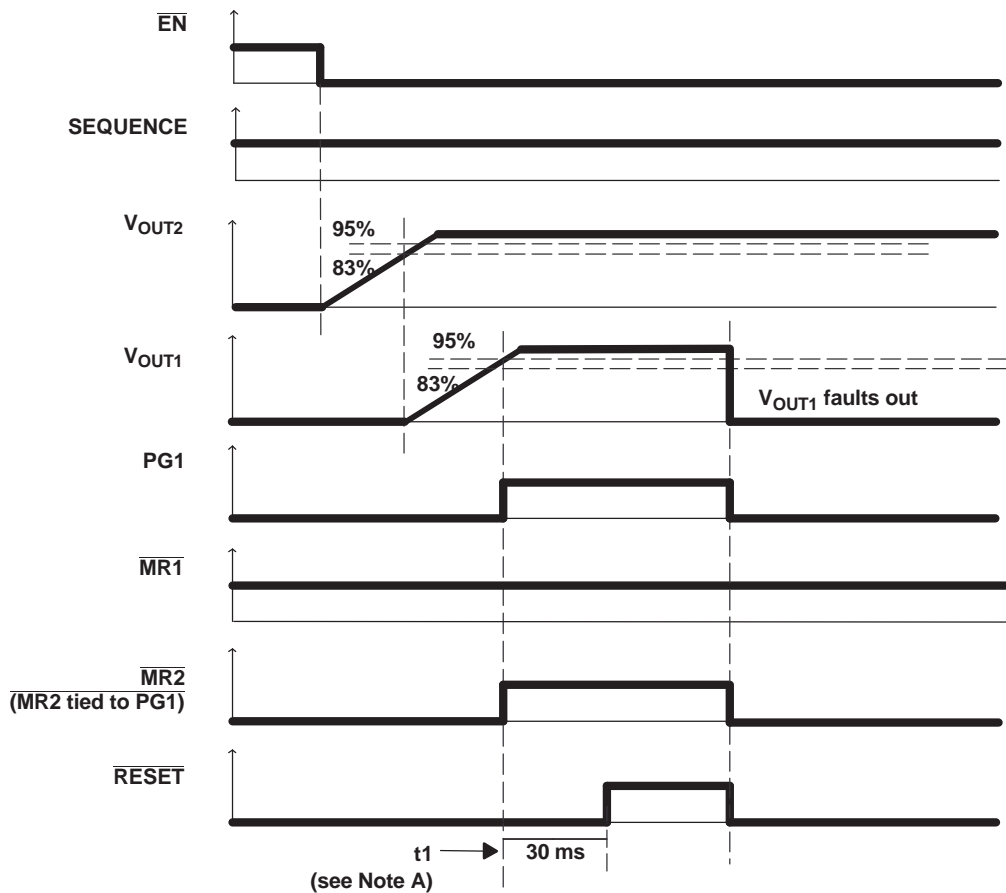
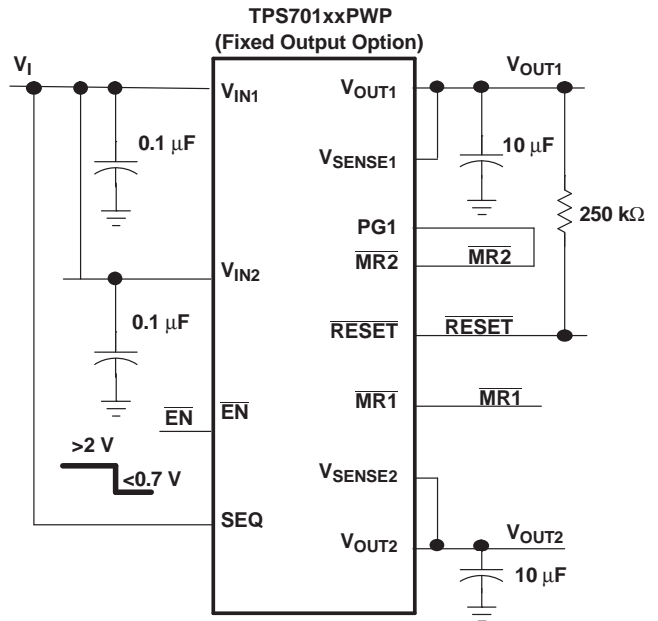

NOTE A: t_1 – Time at which both V_{OUT1} and V_{OUT2} are greater than the PG1 thresholds and $\overline{MR1}$ is logic high.

Figure 29. Timing When V_{OUT1} Faults Out

Application condition: $\overline{\text{MR2}}$ is tied to PG1, V_{IN1} and V_{IN2} are tied to same input voltage, the SEQ is tied to logic high, the device is enabled, and V_{OUT2} faults out.

V_{OUT2} begins to power up when the device is enabled ($\overline{\text{EN}}$ is pulled low). When V_{OUT2} reaches 83% of its regulated voltage, V_{OUT1} begins to power up. When V_{OUT1} reaches 95% of its regulated voltage, PG1 turns on and $\overline{\text{RESET}}$ switches to high voltage level after a 30-ms delay. When V_{OUT2} faults out, V_{OUT1} is powered down because SEQ is high. PG1 is tied to $\overline{\text{MR2}}$ and both change state to logic low. $\overline{\text{RESET}}$ goes low when V_{OUT2} faults out (see Figure 30).

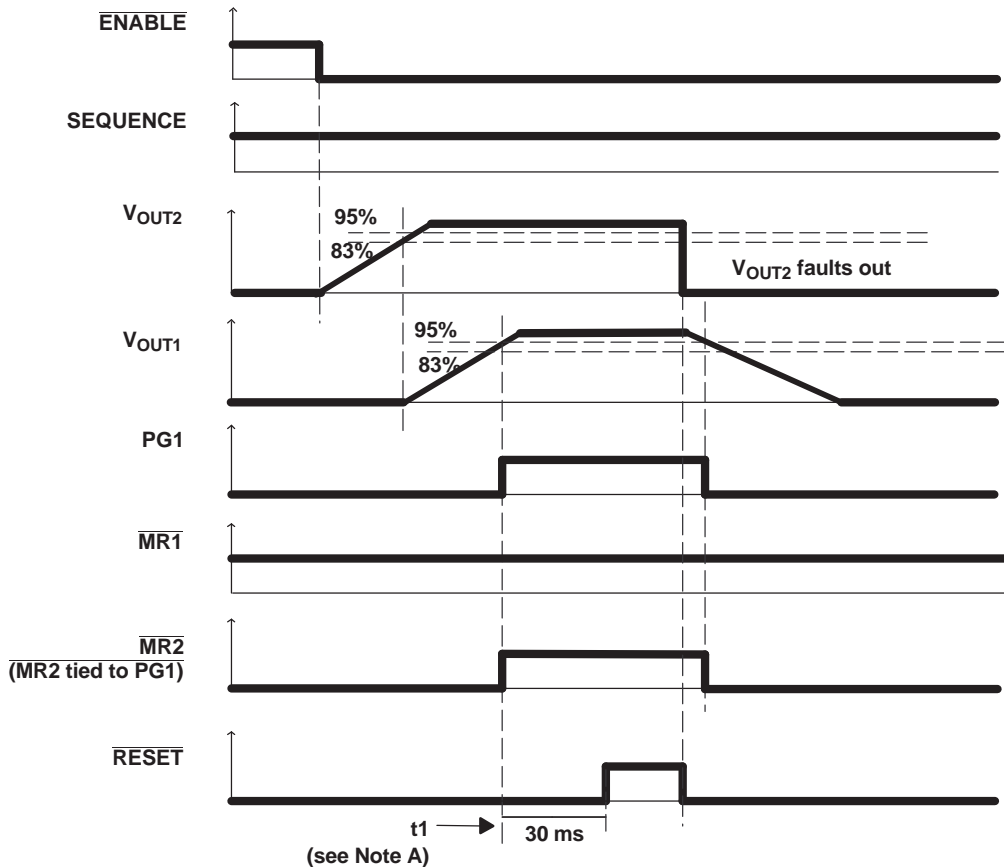
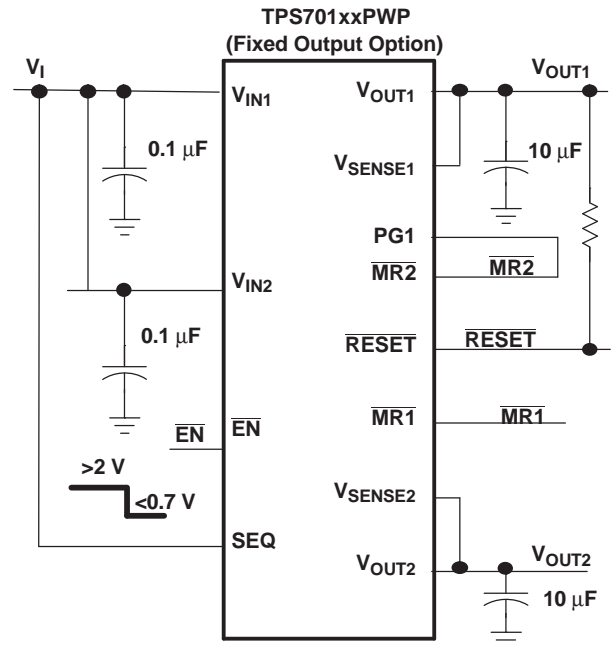

NOTE A: t_1 – Time at which both V_{OUT1} and V_{OUT2} are greater than the PG1 thresholds and $\overline{\text{MR1}}$ is logic high.

Figure 30. Timing When V_{OUT2} Faults Out

Split Voltage DSP Application

Figure 31 shows a typical application where the TPS701xx is powering up a DSP. In this application, by grounding the SEQ pin, V_{OUT1} (I/O) is powered up first and then V_{OUT2} (core).

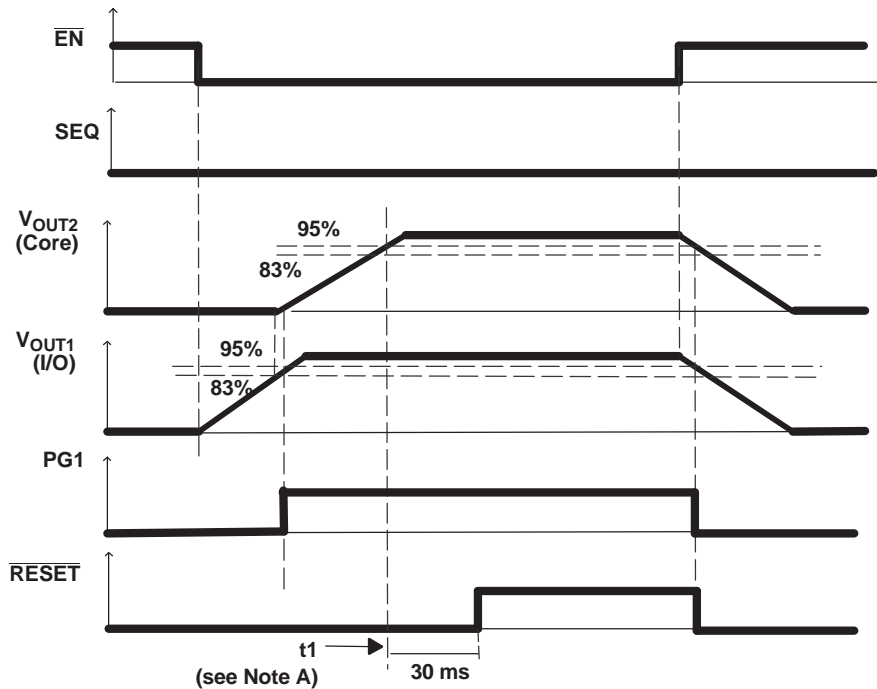
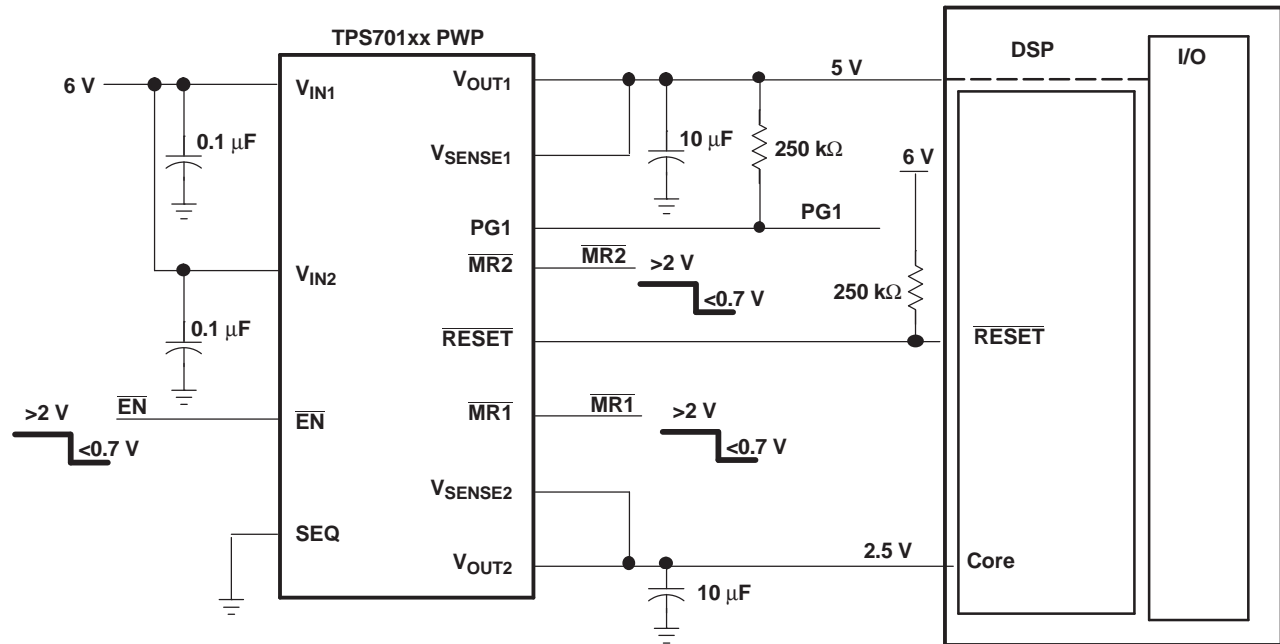

NOTE A: t_1 – Time at which both V_{OUT1} and V_{OUT2} are greater than the PG1 thresholds and $\overline{MR1}$ is logic high.

Figure 31. Application Timing Diagram (SEQ = Low)

Figure 32 shows a typical application where the TPS701xx is powering up a DSP. In this application, by pulling up the SEQ pin, V_{OUT2} (core) is powered up first and then V_{OUT1} (I/O).

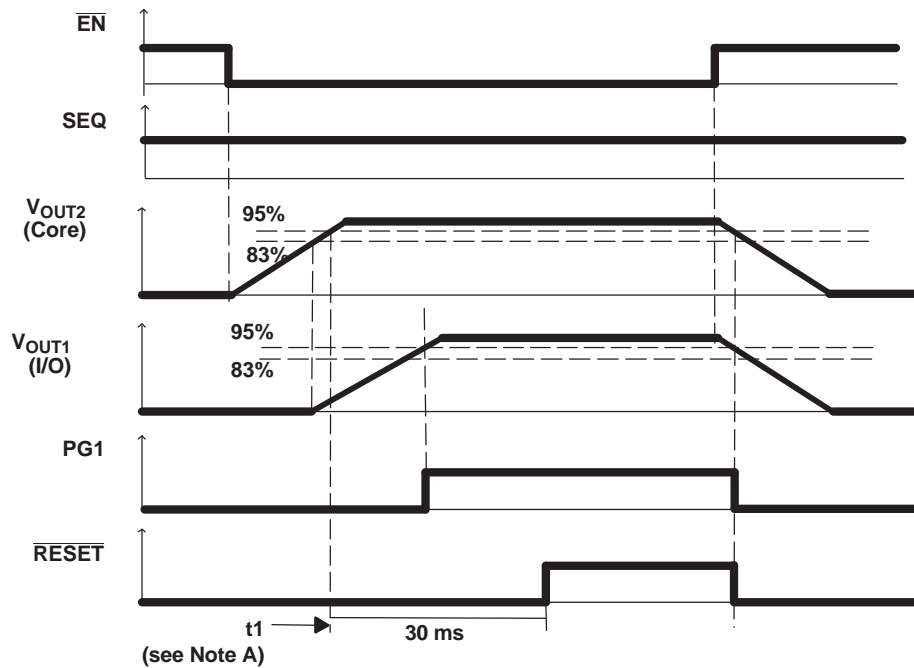
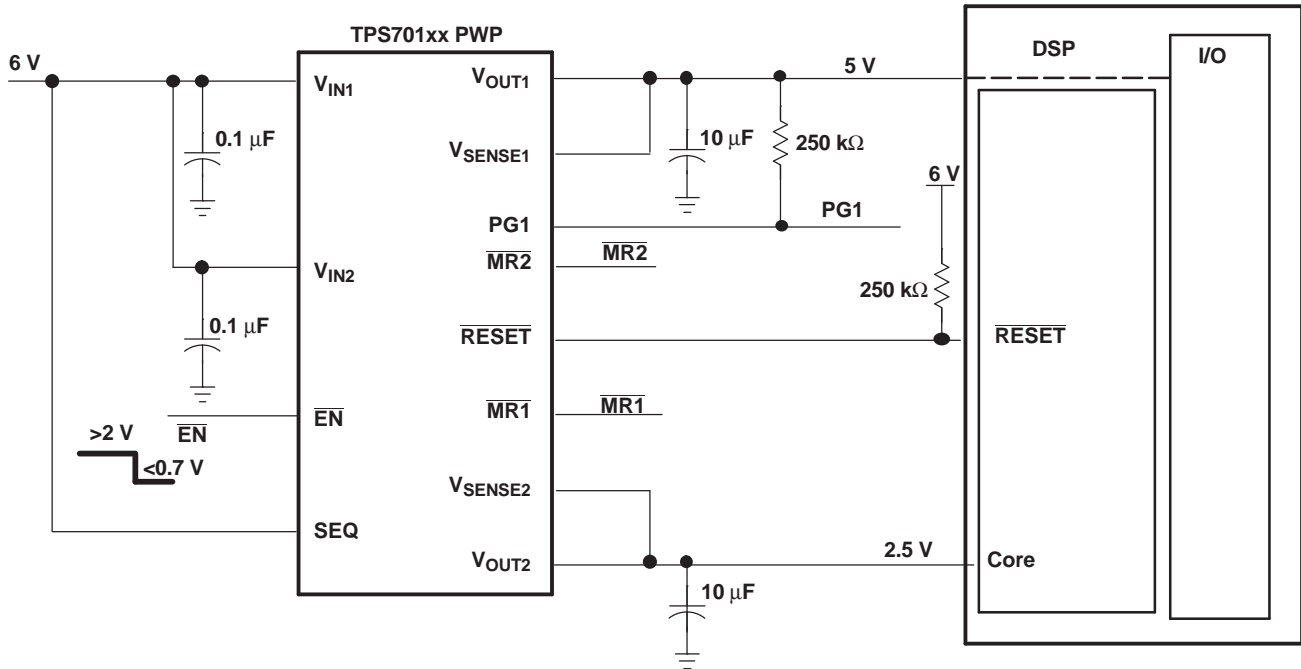

NOTE A: t_1 – Time at which both V_{OUT1} and V_{OUT2} are greater than the PG1 thresholds and $\overline{MR1}$ is logic high.

Figure 32. Application Timing Diagram (SEQ = High)

Input Capacitor

For a typical application, an input bypass capacitor (0.1 μF – 1 μF) is recommended. This capacitor filters any high frequency noise generated in the line. For fast transient condition where droop at the input of the LDO may occur due to high inrush current, it is recommended to place a larger capacitor at the input as well. The size of this capacitor is dependent on the output current and response time of the main power supply, as well as the distance to the V_I pins of the LDO.

Output Capacitor

As with most LDO regulators, the TPS70175 requires an output capacitor connected between OUT and GND to stabilize the internal control loop. The minimum recommended capacitance value is 10 μF and the ESR (equivalent series resistance) must be between 50 m Ω and 2.5 Ω . Capacitor values 10 μF or larger are acceptable, provided the ESR is less than 2.5 Ω . Solid tantalum electrolytic, aluminum electrolytic, and multilayer ceramic capacitors are all suitable, provided they meet the requirements described above. Larger capacitors provide a wider range of stability and better load transient response. [Table 4](#) provides a partial listing of surface-mount capacitors usable with the TPS70175 for fast transient response application.

This information, along with the ESR graphs, is included to assist in selection of suitable capacitance for the user's application. When necessary to achieve low height requirements along with high output current and/or high load capacitance, several higher ESR capacitors can be used in parallel to meet the guidelines above.

Table 4. Partial Listing of TPS70175-Compatible Surface-Mount Capacitors

VALUE	MANUFACTURER	MAXIMUM ESR	MFR PART NO.
22 μF	Kemet	345m Ω	7495C226K0010AS
33 μF	Sanyo	100m Ω	10TPA33M
47 μF	Sanyo	100m Ω	6TPA47M
68 μF	Sanyo	45m Ω	10TPC68M

ESR and Transient Response

LDOs typically require an external output capacitor for stability. In fast transient response applications, capacitors are used to support the load current while the LDO amplifier is responding. In most applications, one capacitor is used to support both functions.

Besides its capacitance, every capacitor also contains parasitic impedances. These parasitic impedances are resistive as well as inductive. The resistive impedance is called *equivalent series resistance* (ESR) and the inductive impedance is called *equivalent series inductance* (ESL). The equivalent schematic diagram of any capacitor can therefore be drawn as shown in [Figure 33](#).



Figure 33. ESR and ESL

In most cases one can neglect the effect of inductive impedance ESL. Therefore, the following application focuses mainly on the parasitic resistance ESR.

[Figure 34](#) shows the output capacitor and its parasitic impedances in a typical LDO output stage.

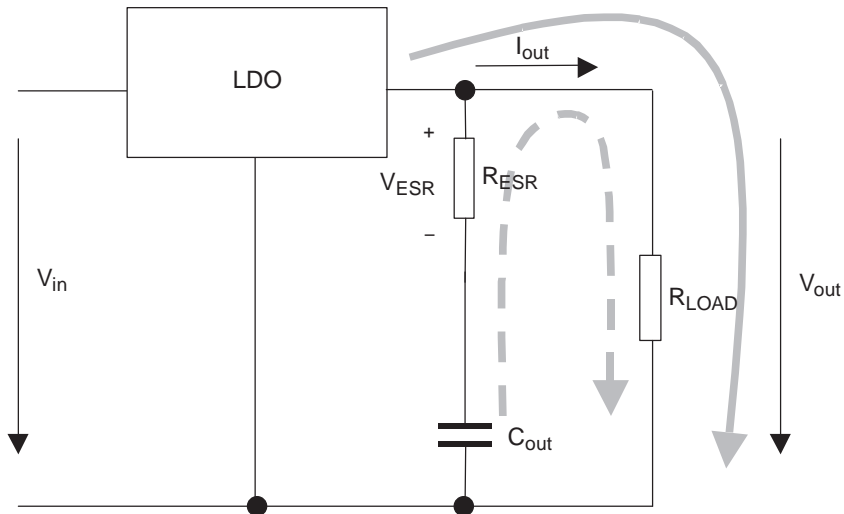

Figure 34. LDO Output Stage with Parasitic Resistances ESR

In steady state (dc state condition), the load current is supplied by the LDO (solid arrow) and the voltage across the capacitor is the same as the output voltage ($V_{(CO)} = V_{OUT}$). This means no current is flowing into the C_O branch. If I_{OUT} suddenly increases (a transient condition), the following occurs:

- The LDO is not able to supply the sudden current need due to its response time (t_1 in Figure 31). Therefore, capacitor C_O provides the current for the new load condition (dashed arrow). C_O now acts like a battery with an internal resistance, ESR. Depending on the current demand at the output, a voltage drop occurs at R_{ESR} . This voltage is shown as V_{ESR} in Figure 30.
- When C_O is conducting current to the load, initial voltage at the load will be $V_O = V_{(CO)} - V_{ESR}$. Due to the discharge of C_O , the output voltage V_O drops continuously until the response time t_1 of the LDO is reached and the LDO resumes supplying the load. From this point, the output voltage starts rising again until it reaches the regulated voltage. This period is shown as t_2 in Figure 35.

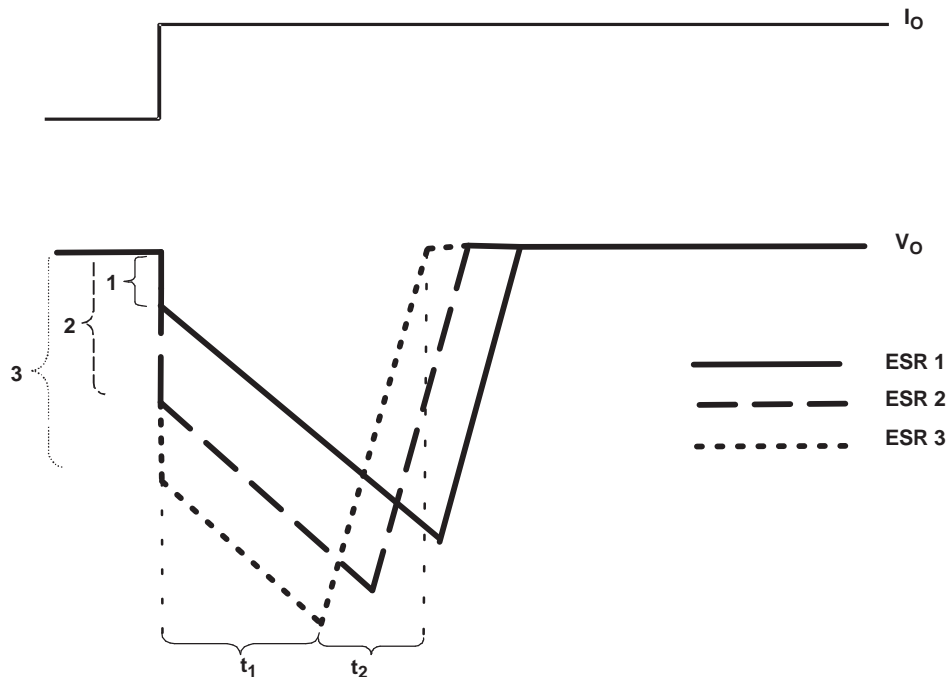

Figure 35. Correlation of Different ESRs and Their Influence on the Regulation of V_O at a Load Step from Low-to-High Output Current

Figure 35 also shows the impact of different ESRs on the output voltage. The left brackets show different levels of ESRs where number 1 displays the lowest and number 3 displays the highest ESR.

From above, the following conclusions can be drawn:

- The higher the ESR, the larger the droop at the beginning of load transient.
- The smaller the output capacitor, the faster the discharge time and the greater the voltage droop during the LDO response period.

Conclusion

To minimize the transient output droop, capacitors must have a low ESR and be large enough to support the minimum output voltage requirement.

Regulator Protection

Both TPS70175 PMOS-pass transistors have built-in back diodes that conduct reverse currents when the input voltage drops below the output voltage (for example, during power-down). Current is conducted from the output to the input and is not internally limited. When extended reverse voltage is anticipated, external limiting may be appropriate.

The TPS70175 also features internal current limiting and thermal protection. During normal operation, the TPS70175 regulator 1 limits output current to approximately 1.6 A (typ) and regulator 2 limits output current to approximately 750 mA (typ). When current limiting engages, the output voltage scales back linearly until the overcurrent condition ends. While current limiting is designed to prevent gross device failure, care should be taken not to exceed the power dissipation ratings of the package. If the temperature of the device exceeds 150°C (typ), thermal-protection circuitry shuts it down. Once the device has cooled below 130°C (typ), regulator operation resumes.

Power Dissipation and Junction Temperature

Specified regulator operation is assured to a junction temperature of 125°C; the maximum junction temperature should be restricted to 125°C under normal operating conditions. This restriction limits the power dissipation the regulator can handle in any given application. To ensure the junction temperature is within acceptable limits, calculate the maximum allowable dissipation, $P_{D(max)}$, and the actual dissipation, P_D , which must be less than or equal to $P_{D(max)}$.

The maximum-power-dissipation limit is determined using [Equation 1](#):

$$P_{D(max)} = \frac{T_{Jmax} - T_A}{R_{\theta JA}} \quad (1)$$

where:

- T_{Jmax} is the maximum allowable junction temperature
- $R_{\theta JA}$ is the thermal resistance junction-to-ambient for the package; that is, 32.6°C/W for the 20-terminal PWP with no airflow
- T_A is the ambient temperature

The regulator dissipation is calculated using [Equation 2](#):

$$P_D = (V_I - V_O) \times I_O \quad (2)$$

Power dissipation resulting from quiescent current is negligible. Excessive power dissipation triggers the thermal protection circuit.

PACKAGING INFORMATION

Orderable Device	Status (1)	Package Type	Package Drawing	Pins	Package Qty	Eco Plan (2)	Lead finish/ Ball material (6)	MSL Peak Temp (3)	Op Temp (°C)	Device Marking (4/5)	Samples
TPS70175QPWPRQ1	ACTIVE	HTSSOP	PWP	20	2000	RoHS & Green	NIPDAU	Level-2-260C-1 YEAR	-40 to 125	70175Q1	Samples

(1) The marketing status values are defined as follows:

ACTIVE: Product device recommended for new designs.

LIFEBUY: TI has announced that the device will be discontinued, and a lifetime-buy period is in effect.

NRND: Not recommended for new designs. Device is in production to support existing customers, but TI does not recommend using this part in a new design.

PREVIEW: Device has been announced but is not in production. Samples may or may not be available.

OBSOLETE: TI has discontinued the production of the device.

(2) **RoHS:** TI defines "RoHS" to mean semiconductor products that are compliant with the current EU RoHS requirements for all 10 RoHS substances, including the requirement that RoHS substance do not exceed 0.1% by weight in homogeneous materials. Where designed to be soldered at high temperatures, "RoHS" products are suitable for use in specified lead-free processes. TI may reference these types of products as "Pb-Free".

RoHS Exempt: TI defines "RoHS Exempt" to mean products that contain lead but are compliant with EU RoHS pursuant to a specific EU RoHS exemption.

Green: TI defines "Green" to mean the content of Chlorine (Cl) and Bromine (Br) based flame retardants meet JS709B low halogen requirements of <=1000ppm threshold. Antimony trioxide based flame retardants must also meet the <=1000ppm threshold requirement.

(3) MSL, Peak Temp. - The Moisture Sensitivity Level rating according to the JEDEC industry standard classifications, and peak solder temperature.

(4) There may be additional marking, which relates to the logo, the lot trace code information, or the environmental category on the device.

(5) Multiple Device Markings will be inside parentheses. Only one Device Marking contained in parentheses and separated by a "-" will appear on a device. If a line is indented then it is a continuation of the previous line and the two combined represent the entire Device Marking for that device.

(6) Lead finish/Ball material - Orderable Devices may have multiple material finish options. Finish options are separated by a vertical ruled line. Lead finish/Ball material values may wrap to two lines if the finish value exceeds the maximum column width.

Important Information and Disclaimer:The information provided on this page represents TI's knowledge and belief as of the date that it is provided. TI bases its knowledge and belief on information provided by third parties, and makes no representation or warranty as to the accuracy of such information. Efforts are underway to better integrate information from third parties. TI has taken and continues to take reasonable steps to provide representative and accurate information but may not have conducted destructive testing or chemical analysis on incoming materials and chemicals. TI and TI suppliers consider certain information to be proprietary, and thus CAS numbers and other limited information may not be available for release.

In no event shall TI's liability arising out of such information exceed the total purchase price of the TI part(s) at issue in this document sold by TI to Customer on an annual basis.

TAPE AND REEL INFORMATION



QUADRANT ASSIGNMENTS FOR PIN 1 ORIENTATION IN TAPE



*All dimensions are nominal

Device	Package Type	Package Drawing	Pins	SPQ	Reel Diameter (mm)	Reel Width W1 (mm)	A0 (mm)	B0 (mm)	K0 (mm)	P1 (mm)	W (mm)	Pin1 Quadrant
TPS70175QPWPRQ1	HTSSOP	PWP	20	2000	330.0	16.4	6.95	7.1	1.6	8.0	16.0	Q1

TAPE AND REEL BOX DIMENSIONS



*All dimensions are nominal

Device	Package Type	Package Drawing	Pins	SPQ	Length (mm)	Width (mm)	Height (mm)
TPS70175QPWPRQ1	HTSSOP	PWP	20	2000	350.0	350.0	43.0

MECHANICAL DATA

PWP (R-PDSO-G20)

PowerPAD™ PLASTIC SMALL OUTLINE

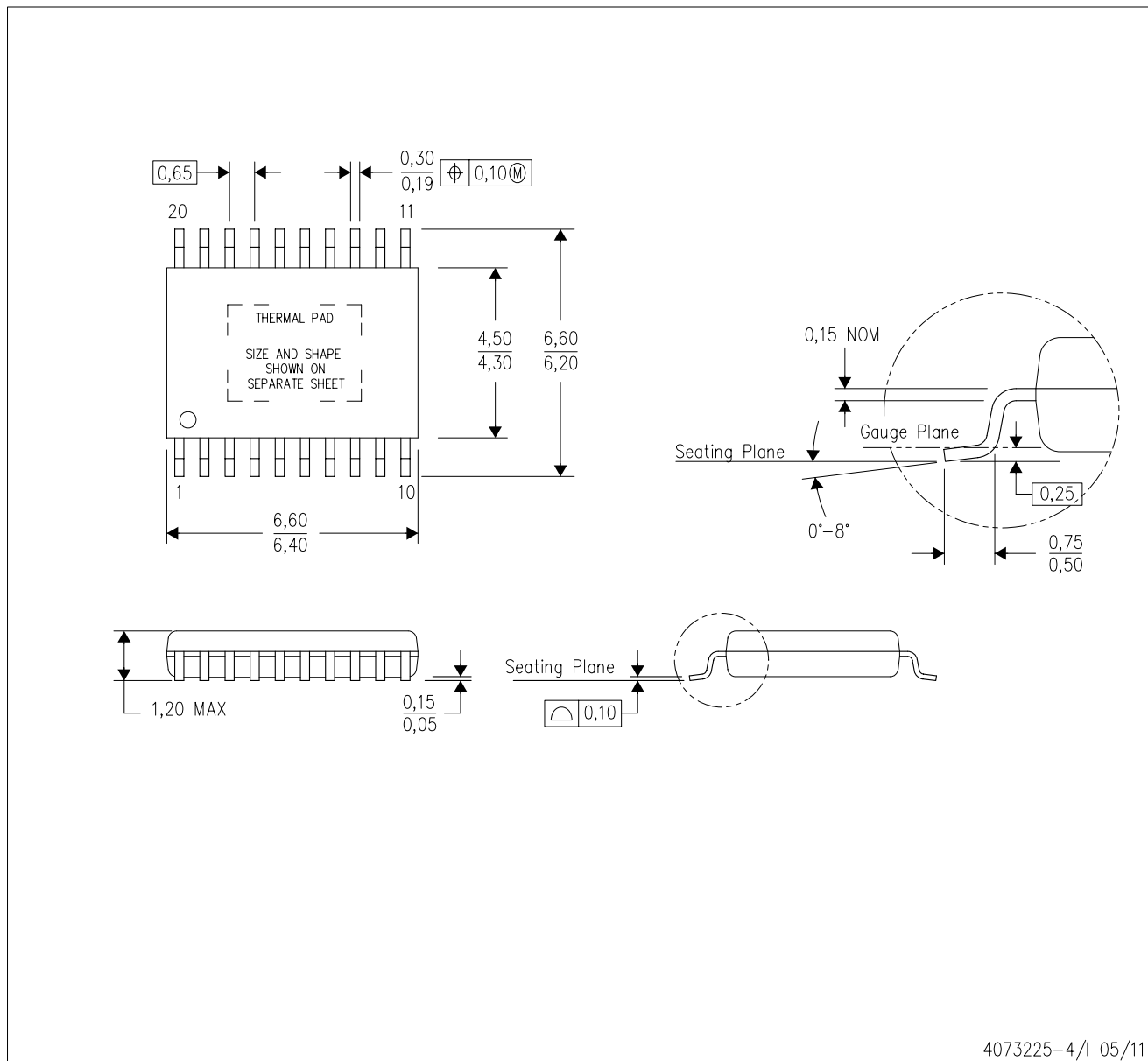

4073225-4/1 05/11

- NOTES:
- All linear dimensions are in millimeters.
 - This drawing is subject to change without notice.
 - Body dimensions do not include mold flash or protrusions. Mold flash and protrusion shall not exceed 0.15 per side.
 - This package is designed to be soldered to a thermal pad on the board. Refer to Technical Brief, PowerPad Thermally Enhanced Package, Texas Instruments Literature No. SLMA002 for information regarding recommended board layout. This document is available at www.ti.com <<http://www.ti.com>>.
 - See the additional figure in the Product Data Sheet for details regarding the exposed thermal pad features and dimensions.
 - Falls within JEDEC MO-153

PowerPAD is a trademark of Texas Instruments.

THERMAL PAD MECHANICAL DATA

PWP (R-PDSO-G20) PowerPAD™ SMALL PLASTIC OUTLINE

THERMAL INFORMATION

This PowerPAD™ package incorporates an exposed thermal pad that is designed to be attached to a printed circuit board (PCB). The thermal pad must be soldered directly to the PCB. After soldering, the PCB can be used as a heatsink. In addition, through the use of thermal vias, the thermal pad can be attached directly to the appropriate copper plane shown in the electrical schematic for the device, or alternatively, can be attached to a special heatsink structure designed into the PCB. This design optimizes the heat transfer from the integrated circuit (IC).

For additional information on the PowerPAD package and how to take advantage of its heat dissipating abilities, refer to Technical Brief, PowerPAD Thermally Enhanced Package, Texas Instruments Literature No. SLMA002 and Application Brief, PowerPAD Made Easy, Texas Instruments Literature No. SLMA004. Both documents are available at www.ti.com.

The exposed thermal pad dimensions for this package are shown in the following illustration.

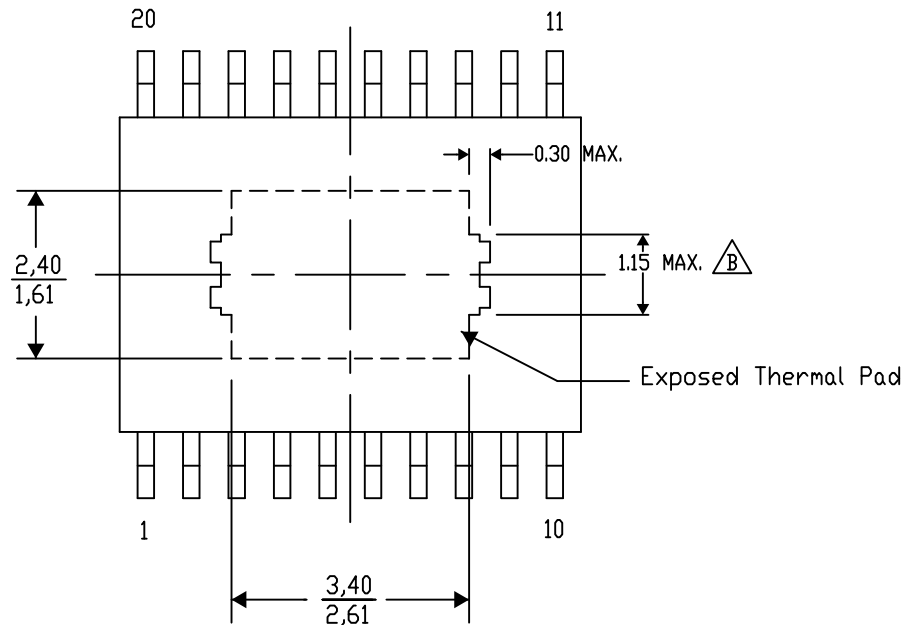

Top View

Exposed Thermal Pad Dimensions

4206332-15/AO 01/16

NOTE: A. All linear dimensions are in millimeters

 Exposed tie strap features may not be present.

PowerPAD is a trademark of Texas Instruments

PWP (R-PDSO-G20)

PowerPAD™ PLASTIC SMALL OUTLINE

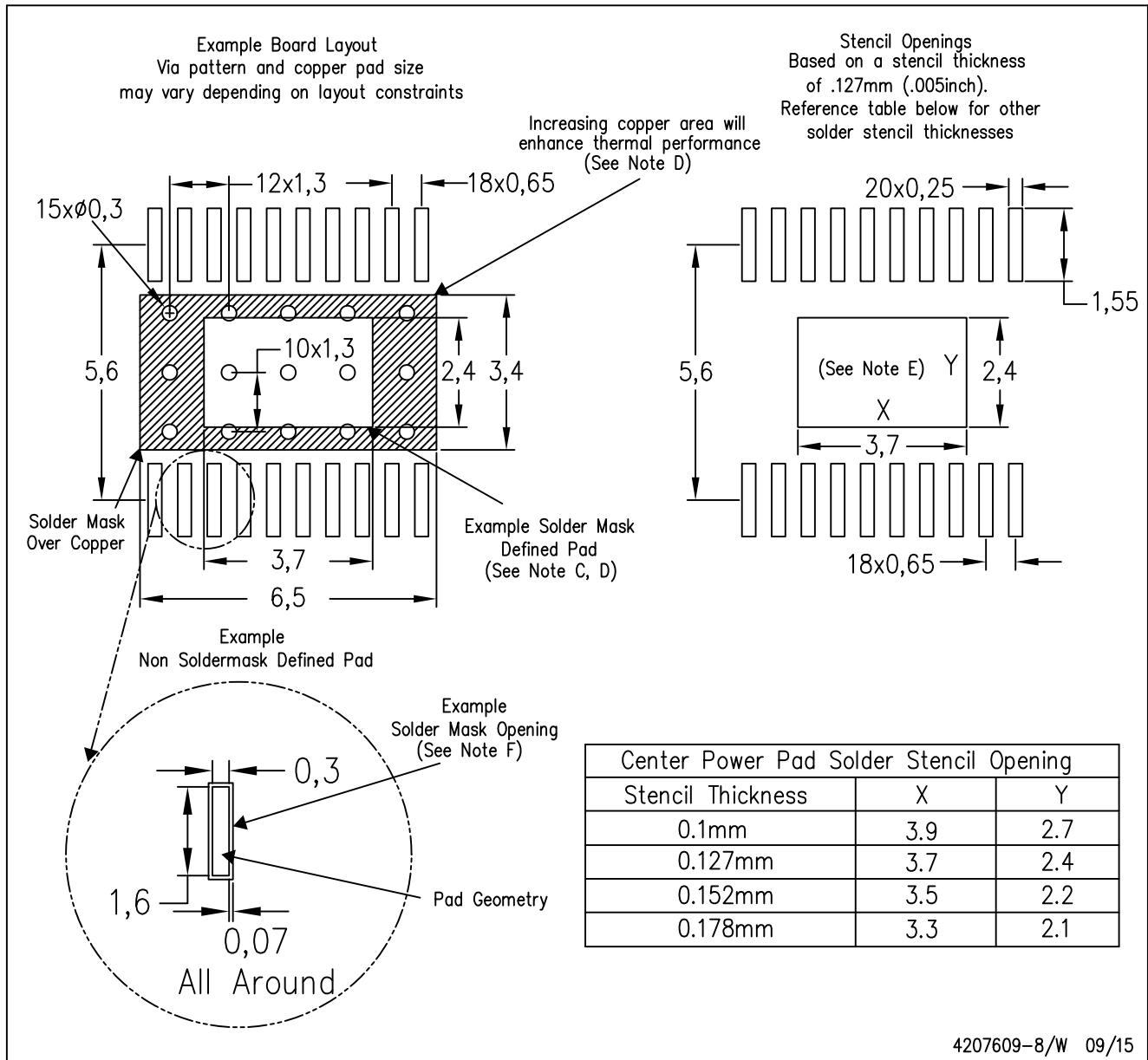

- NOTES:
- A. All linear dimensions are in millimeters.
 - B. This drawing is subject to change without notice.
 - C. Customers should place a note on the circuit board fabrication drawing not to alter the center solder mask defined pad.
 - D. This package is designed to be soldered to a thermal pad on the board. Refer to Technical Brief, PowerPad Thermally Enhanced Package, Texas Instruments Literature No. SLMA002, SLMA004, and also the Product Data Sheets for specific thermal information, via requirements, and recommended board layout. These documents are available at www.ti.com <<http://www.ti.com>>. Publication IPC-7351 is recommended for alternate designs.
 - E. Laser cutting apertures with trapezoidal walls and also rounding corners will offer better paste release. Customers should contact their board assembly site for stencil design recommendations. Example stencil design based on a 50% volumetric metal load solder paste. Refer to IPC-7525 for other stencil recommendations.
 - F. Customers should contact their board fabrication site for solder mask tolerances between and around signal pads.

IMPORTANT NOTICE AND DISCLAIMER

TI PROVIDES TECHNICAL AND RELIABILITY DATA (INCLUDING DATASHEETS), DESIGN RESOURCES (INCLUDING REFERENCE DESIGNS), APPLICATION OR OTHER DESIGN ADVICE, WEB TOOLS, SAFETY INFORMATION, AND OTHER RESOURCES "AS IS" AND WITH ALL FAULTS, AND DISCLAIMS ALL WARRANTIES, EXPRESS AND IMPLIED, INCLUDING WITHOUT LIMITATION ANY IMPLIED WARRANTIES OF MERCHANTABILITY, FITNESS FOR A PARTICULAR PURPOSE OR NON-INFRINGEMENT OF THIRD PARTY INTELLECTUAL PROPERTY RIGHTS.

These resources are intended for skilled developers designing with TI products. You are solely responsible for (1) selecting the appropriate TI products for your application, (2) designing, validating and testing your application, and (3) ensuring your application meets applicable standards, and any other safety, security, or other requirements. These resources are subject to change without notice. TI grants you permission to use these resources only for development of an application that uses the TI products described in the resource. Other reproduction and display of these resources is prohibited. No license is granted to any other TI intellectual property right or to any third party intellectual property right. TI disclaims responsibility for, and you will fully indemnify TI and its representatives against, any claims, damages, costs, losses, and liabilities arising out of your use of these resources.

TI's products are provided subject to TI's Terms of Sale (www.ti.com/legal/termsofsale.html) or other applicable terms available either on ti.com or provided in conjunction with such TI products. TI's provision of these resources does not expand or otherwise alter TI's applicable warranties or warranty disclaimers for TI products.

Mailing Address: Texas Instruments, Post Office Box 655303, Dallas, Texas 75265
Copyright © 2020, Texas Instruments Incorporated