

## DRV8833C 双路 H 桥电机驱动器

### 1 特性

- 带电流控制的双 H 桥电机驱动器
  - 1 个或 2 个直流电机或者 1 个步进电机
  - 低导通电阻：高侧 + 低侧 (HS + LS) = 1735mΩ (25°C 时的典型值)
- 输出电流能力 ( $V_M = 5V$ , 25°C 时)
  - 散热薄型小外形尺寸 PWP (HTSSOP) 封装
    - 每个 H 桥的均方根 (RMS) 电流为 0.7A, 峰值 1A
    - 并行模式下 RMS 为 1.4A
  - 四方扁平无引线 RTE (QFN) 封装
    - 每个 H 桥的均方根 (RMS) 电流为 0.6A, 峰值 1A
    - 并行模式下 RMS 为 1.2A
- 宽电源电压范围
  - 2.7V 至 10.8V
- 集成电流调节
- 简易脉宽调制 (PWM) 接口
- 1.6μA 低电流睡眠模式 (电压 5V 时)
- 小型封装尺寸
  - 16HTSSOP (PowerPAD™) 5.00 × 6.40mm
  - 16 QFN (PowerPAD) 3.00 × 3.00mm
- 保护特性
  - $V_M$  欠压闭锁 (UVLO)
  - 过流保护 (OCP)
  - 热关断 (TSD)
  - 故障指示引脚 (nFAULT)

### 2 应用

- 销售点打印机
- 视频安保摄像机
- 办公自动化设备
- 游戏机
- 机器人
- 电池供电式玩具

### 3 说明

DRV8833C 为玩具、打印机及其他机电一体化应用提供了一款双桥电机驱动器解决方案。

该器件具有两个 H 桥驱动器，能够驱动两个直流电刷电机、一个双极性步进电机、螺线管或其它电感性负载。

每个 H 桥输出都包括一对 N 通道和 P 通道金属氧化物半导体场效应晶体管 (MOSFET) 以及用于调节绕组电流的电路。借助正确的印刷电路板 (PCB) 设计，DRV8833C 的每个 H 桥能够持续驱动高达 700mA RMS (或 DC) (在 25°C 采用 5V  $V_M$  电源时)。该器件可支持每个 H 桥高达 1A 的峰值电流。在较低的  $V_M$  电压条件下，电流能力略有下降。

输出引脚发生故障时，还可提供用于过流保护、短路保护、UVLO 和过热保护的内部关断功能。另外，还提供了一种低功耗睡眠模式。

器件信息(1)

部件号	封装	封装尺寸 (标称值)
DRV8833C	HTSSOP (16)	5.00mm x 6.40mm
	四方扁平无引线 (QFN) (16)	3.00mm x 3.00mm

(1) 要了解所有可用封装，请见数据表末尾的可订购产品附录。

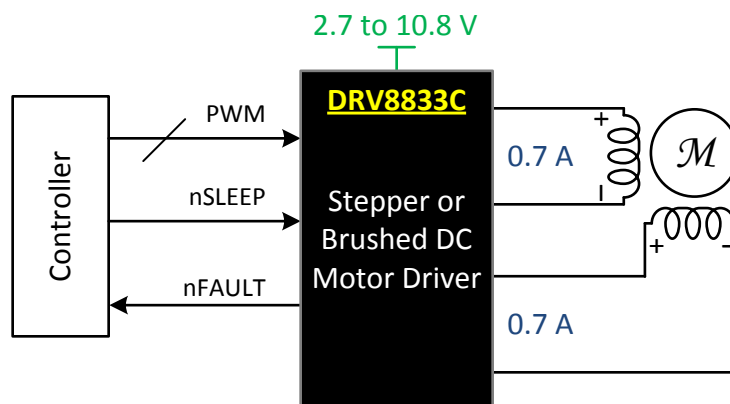

## 目录

<b>1</b>	特性 .....	<b>1</b>	7.3	Feature Description.....	<b>9</b>
<b>2</b>	应用 .....	<b>1</b>	7.4	Device Functional Modes.....	<b>13</b>
<b>3</b>	说明 .....	<b>1</b>	<b>8</b>	<b>Application and Implementation .....</b>	<b>14</b>
<b>4</b>	修订历史记录 .....	<b>2</b>	8.1	Application Information.....	<b>14</b>
<b>5</b>	<b>Pin Configuration and Functions .....</b>	<b>3</b>	8.2	Typical Application .....	<b>14</b>
<b>6</b>	<b>Specifications.....</b>	<b>4</b>	<b>9</b>	<b>Power Supply Recommendations.....</b>	<b>17</b>
6.1	Absolute Maximum Ratings .....	<b>4</b>	9.1	Sizing Bulk Capacitance for Motor Drive Systems ..	<b>17</b>
6.2	Handling Ratings.....	<b>4</b>	<b>10</b>	<b>Layout.....</b>	<b>18</b>
6.3	Recommended Operating Conditions.....	<b>4</b>	10.1	Layout Guidelines .....	<b>18</b>
6.4	Thermal Information .....	<b>5</b>	10.2	Layout Example .....	<b>18</b>
6.5	Electrical Characteristics.....	<b>5</b>	<b>11</b>	<b>器件和文档支持 .....</b>	<b>19</b>
6.6	Typical Characteristics.....	<b>7</b>	11.1	商标.....	<b>19</b>
<b>7</b>	<b>Detailed Description .....</b>	<b>8</b>	11.2	静电放电警告.....	<b>19</b>
7.1	Overview .....	<b>8</b>	11.3	术语表 .....	<b>19</b>
7.2	Functional Block Diagram .....	<b>8</b>	<b>12</b>	<b>机械封装和可订购信息 .....</b>	<b>19</b>

## 4 修订历史记录

日期	修订版本	注释
2014 年 8 月	*	最初发布。

## 5 Pin Configuration and Functions

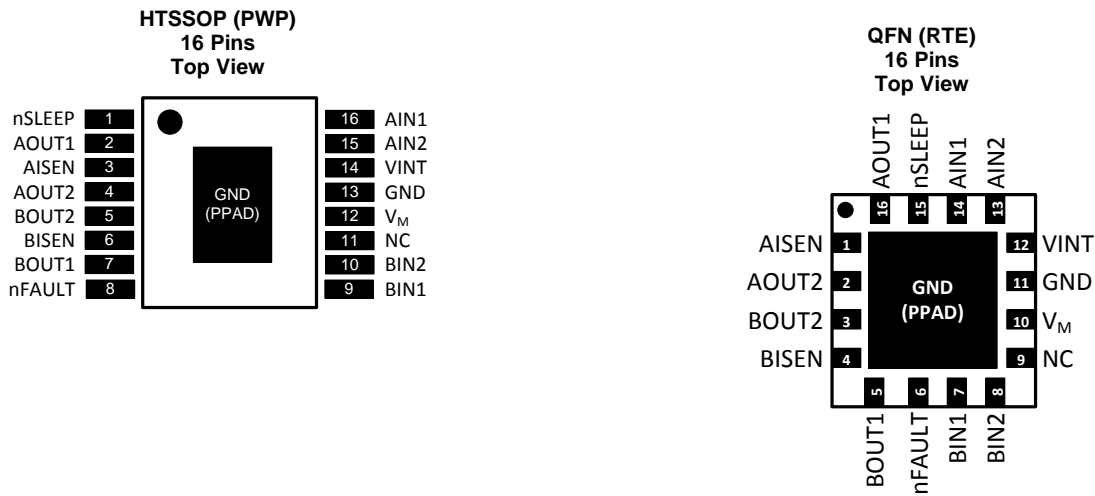

### Pin Functions

PIN			TYPE	DESCRIPTION	
NAME	PWP	RTE			
<b>POWER AND GROUND</b>					
GND	13	11	PWR	Device ground	Both the GND pin and device PowerPAD must be connected to ground
VINT	14	12	—	Internal regulator (3.3 V)	Internal supply voltage; bypass to GND with 2.2- $\mu$ F, 6.3-V capacitor
V <sub>M</sub>	12	10	PWR	Power supply	Connect to motor supply voltage; bypass to GND with a 10- $\mu$ F (minimum) capacitor rated for V <sub>M</sub>
<b>CONTROL</b>					
AIN1	16	14	I	H-bridge A PWM input	Controls the state of AOUT1 and AOUT2; internal pulldown
AIN2	15	13			
BIN1	9	7	I	H-bridge B PWM input	Controls the state of BOUT1 and BOUT2; internal pulldown
BIN2	10	8			
nSLEEP	1	15	I	Sleep mode input	Logic high to enable device; logic low to enter low-power sleep mode; internal pulldown
<b>STATUS</b>					
nFAULT	8	6	OD	Fault indication pin	Pulled logic low with fault condition; open-drain output requires an external pullup
<b>OUTPUT</b>					
AISEN	3	1	O	Bridge A sense	Sense resistor to GND sets PWM current regulation level (see <a href="#">PWM Motor Drivers</a> )
AOUT1	2	16	O	Bridge A output	Positive current is AOUT1 → AOUT2
AOUT2	4	2			
BISEN	6	4	O	Bridge B sense	Sense resistor to GND sets PWM current regulation level (see <a href="#">PWM Motor Drivers</a> )
BOUT1	7	5	O	Bridge B output	Positive current is BOUT1 → BOUT2
BOUT2	5	3			

### External Components

Component	Pin 1	Pin 2	Recommended
C <sub>VM</sub>	V <sub>M</sub>	GND	10- $\mu$ F <sup>(1)</sup> ceramic capacitor rated for V <sub>M</sub>
C <sub>VINT</sub>	VINT	GND	6.3-V, 2.2- $\mu$ F ceramic capacitor
R <sub>nFAULT</sub>	VINT <sup>(2)</sup>	nFAULT	>1 k $\Omega$
R <sub>AISEN</sub>	AISEN	GND	Sense resistor, see <a href="#">Typical Application</a> for sizing
R <sub>BISEN</sub>	BISEN	GND	Sense resistor, see <a href="#">Typical Application</a> for sizing

- (1) Proper bulk capacitance sizing depends on the motor power.  
 (2) nFAULT may be pulled up to an external supply rated < 5.5 V.

## 6 Specifications

### 6.1 Absolute Maximum Ratings

over operating free-air temperature (unless otherwise noted) <sup>(1)</sup>

		MIN	MAX	UNIT
Voltage	Power supply (V <sub>M</sub> )	-0.3	11.8	V
	Internal regulator (VINT)	-0.3	3.8	V
	Control pins (AIN1, AIN2, BIN1, BIN2, nSLEEP, nFAULT)	-0.3	7	V
	Continuous phase node pins (AOUT1, AOUT2, BOUT1, BOUT2)	-0.3	V <sub>M</sub> + 0.5	V
	Pulsed 10 $\mu$ s phase node pins (AOUT1, AOUT2, BOUT1, BOUT2)	-1	V <sub>M</sub> + 1	V
	Continuous shunt amplifier input pins (AISEN, BISEN)	-0.3	0.5	V
	Pulsed 10 $\mu$ s shunt amplifier input pins (AISEN, BISEN)	-1	1	V
Peak drive current (AOUT1, AOUT2, BOUT1, BOUT2, AISEN, BISEN)		Internally limited		A
T <sub>J</sub>	Operating junction temperature	-40	150	$^{\circ}$ C

- (1) Stresses beyond those listed under *Absolute Maximum Ratings* may cause permanent damage to the device. These are stress ratings only, which do not imply functional operation of the device at these or any other conditions beyond those indicated under *Recommended Operating Conditions*. Exposure to absolute-maximum-rated conditions for extended periods may affect device reliability.

### 6.2 Handling Ratings

		MIN	MAX	UNIT	
T <sub>stg</sub>	Storage temperature range	-65	150	$^{\circ}$ C	
V <sub>(ESD)</sub>	Electrostatic discharge	Human body model (HBM), per ANSI/ESDA/JEDEC JS-001, all pins <sup>(1)</sup>	-2000	2000	V
		Charged device model (CDM), per JEDEC specification JESD22-C101, all pins <sup>(2)</sup>	-1000	1000	

- (1) JEDEC document JEP155 states that 500-V HBM allows safe manufacturing with a standard ESD control process.  
 (2) JEDEC document JEP157 states that 250-V CDM allows safe manufacturing with a standard ESD control process.

### 6.3 Recommended Operating Conditions

over operating free-air temperature range (unless otherwise noted)

		MIN	MAX	UNIT	
V <sub>M</sub>	Power supply voltage range <sup>(1)</sup>	2.7	10.8	V	
V <sub>I</sub>	Logic level input voltage	0	5.5	V	
I <sub>RMS</sub>	Motor RMS current <sup>(2)</sup>	PWP package	0	0.7	A
		RTE package	0	0.6	A
f <sub>PWM</sub>	Applied PWM signal to AIN1, AIN2, BIN1, or BIN2	0	200	kHz	
T <sub>A</sub>	Operating ambient temperature	-40	85	$^{\circ}$ C	

- (1) Note that when V<sub>M</sub> is below 5 V, R<sub>DS(ON)</sub> increases and maximum output current is reduced.  
 (2) Power dissipation and thermal limits must be observed.

## 6.4 Thermal Information

THERMAL METRIC <sup>(1)</sup>		DRV8833C		UNIT
		HTSSOP	QFN	
		16 PINS	16 PINS	
R <sub>θJA</sub>	Junction-to-ambient thermal resistance	40.5	44.7	°C/W
R <sub>θJC(top)</sub>	Junction-to-case (top) thermal resistance	32.9	48.5	
R <sub>θJB</sub>	Junction-to-board thermal resistance	28.8	16.8	
ψ <sub>JT</sub>	Junction-to-top characterization parameter	0.6	0.7	
ψ <sub>JB</sub>	Junction-to-board characterization parameter	11.5	16.7	
R <sub>θJC(bot)</sub>	Junction-to-case (bottom) thermal resistance	4.8	4.2	

(1) For more information about traditional and new thermal metrics, see the *IC Package Thermal Metrics* application report, [SPRA953](#).

## 6.5 Electrical Characteristics

over operating free-air temperature range (unless otherwise noted)

PARAMETER		TEST CONDITIONS	MIN	TYP	MAX	UNIT
<b>POWER SUPPLIES (V<sub>M</sub>, V<sub>INT</sub>)</b>						
V <sub>M</sub>	V <sub>M</sub> operating voltage		2.7		10.8	V
I <sub>VM</sub>	V <sub>M</sub> operating supply current	V <sub>M</sub> = 5 V, xINx low, nSLEEP high		1.7	3	mA
I <sub>VMQ</sub>	V <sub>M</sub> sleep mode supply current	V <sub>M</sub> = 5 V, nSLEEP low		1.6	2.7	μA
t <sub>SLEEP</sub>	Sleep time	nSLEEP low to sleep mode		10		μs
t <sub>WAKE</sub>	Wake-up time	nSLEEP high to output transition		155		μs
t <sub>ON</sub>	Turn-on time	V <sub>M</sub> > V <sub>UVLO</sub> to output transition		25		μs
V <sub>INT</sub>	Internal regulator voltage	V <sub>M</sub> = 5 V	3	3.3	3.6	V
<b>CONTROL INPUTS (AIN1, AIN2, BIN1, BIN2, nSLEEP)</b>						
V <sub>IL</sub>	Input logic low voltage	xINx	0		0.7	V
		nSLEEP	0		0.5	
V <sub>IH</sub>	Input logic high voltage	xINx	2		5.5	V
		nSLEEP	2.5		5.5	
V <sub>HYS</sub>	Input logic hysteresis		350	400	650	mV
I <sub>IL</sub>	Input logic low current	V <sub>IN</sub> = 0 V	-1		1	μA
I <sub>IH</sub>	Input logic high current	V <sub>IN</sub> = 5 V			50	μA
R <sub>PD</sub>	Pull-down resistance	xINx	100	150	250	kΩ
		nSLEEP	380	500	750	
t <sub>DEG</sub>	Input deglitch time			575		ns
t <sub>PROP</sub>	Propagation delay INx to OUTx	V <sub>M</sub> = 5 V		1.2		μs
<b>CONTROL OUTPUTS (nFAULT)</b>						
V <sub>OL</sub>	Output logic low voltage	I <sub>O</sub> = 5 mA			0.5	V
I <sub>OH</sub>	Output logic high leakage	R <sub>PULLUP</sub> = 1 kΩ to 5 V	-1		1	μA
<b>MOTOR DRIVER OUTPUTS (AOUT1, AOUT2, BOUT1, BOUT2)</b>						
R <sub>DS(ON)</sub>	High-side FET on-resistance	V <sub>M</sub> = 5 V, I = 0.2 A, T <sub>A</sub> = 25°C		1180		mΩ
		V <sub>M</sub> = 5 V, I = 0.2 A, T <sub>A</sub> = 85°C <sup>(1)</sup>		1400	1475	
		V <sub>M</sub> = 2.7 V, I = 0.2 A, T <sub>A</sub> = 25°C		1550		
		V <sub>M</sub> = 2.7 V, I = 0.2 A, T <sub>A</sub> = 85°C <sup>(1)</sup>		1875	1975	
R <sub>DS(ON)</sub>	Low-side FET on-resistance	V <sub>M</sub> = 5 V, I = 0.2 A, T <sub>A</sub> = 25°C		555		mΩ
		V <sub>M</sub> = 5 V, I = 0.2 A, T <sub>A</sub> = 85°C <sup>(1)</sup>		675	705	
		V <sub>M</sub> = 2.7 V, I = 0.2 A, T <sub>A</sub> = 25°C		635		
		V <sub>M</sub> = 2.7 V, I = 0.2 A, T <sub>A</sub> = 85°C <sup>(1)</sup>		775	815	

(1) Not tested in production; based on design and characterization data

**Electrical Characteristics (continued)**

over operating free-air temperature range (unless otherwise noted)

PARAMETER		TEST CONDITIONS	MIN	TYP	MAX	UNIT
$I_{OFF}$	Off-state leakage current	$V_M = 5\text{ V}$	-1		1	$\mu\text{A}$
$t_{RISE}$	Output rise time	$V_M = 5\text{ V}; R_L = 16\ \Omega$ to GND		70		ns
$t_{FALL}$	Output fall time	$V_M = 5\text{ V}; R_L = 16\ \Omega$ to $V_M$		80		ns
$t_{DEAD}$	Output dead time	Internal dead time		450		ns
<b>PWM CURRENT CONTROL (AISEN, BISEN)</b>						
$V_{TRIP}$	xISEN trip voltage		160	200	240	mV
$t_{OFF}$	Current control constant off time	Internal PWM constant off time		20		$\mu\text{s}$
<b>PROTECTION CIRCUITS</b>						
$V_{UVLO}$	$V_M$ undervoltage lockout	$V_M$ falling; UVLO report			2.6	V
		$V_M$ rising; UVLO recovery			2.7	
$V_{UVLO,HYS}$	$V_M$ undervoltage hysteresis	Rising to falling threshold		90		mV
$I_{OCP}$	Overcurrent protection trip level		1			A
$t_{DEG}$	Overcurrent deglitch time			2.3		$\mu\text{s}$
$t_{OCP}$	Overcurrent protection period			1.4		ms
$T_{TSD}^{(1)}$	Thermal shutdown temperature	Die temperature, $T_J$	150			$^{\circ}\text{C}$
$T_{HYS}$	Thermal shutdown hysteresis	Die temperature, $T_J$		20		$^{\circ}\text{C}$

## 6.6 Typical Characteristics

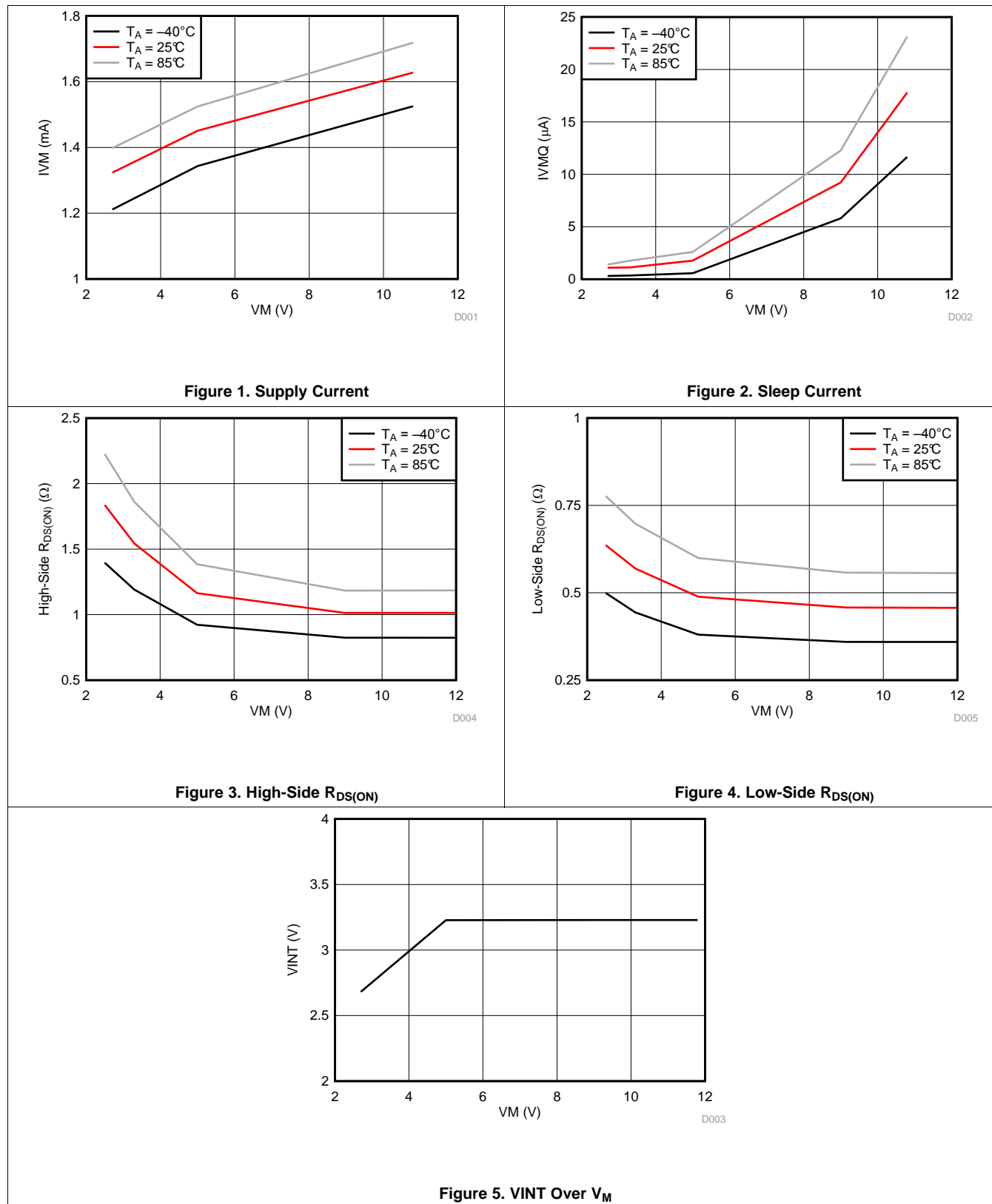

## 7 Detailed Description

### 7.1 Overview

The DRV8833C device is an integrated motor driver solution for brushed DC or bipolar stepper motors. The device integrates two PMOS + NMOS H-bridges and current regulation circuitry. The DRV8833C can be powered with a supply voltage from 2.7 to 10.8 V and can provide an output current up to 700 mA RMS.

A simple PWM interface allows easy interfacing to the controller circuit.

The current regulation is a 20- $\mu$ s fixed off-time slow decay.

The device includes a low-power sleep mode, which lets the system save power when not driving the motor.

### 7.2 Functional Block Diagram

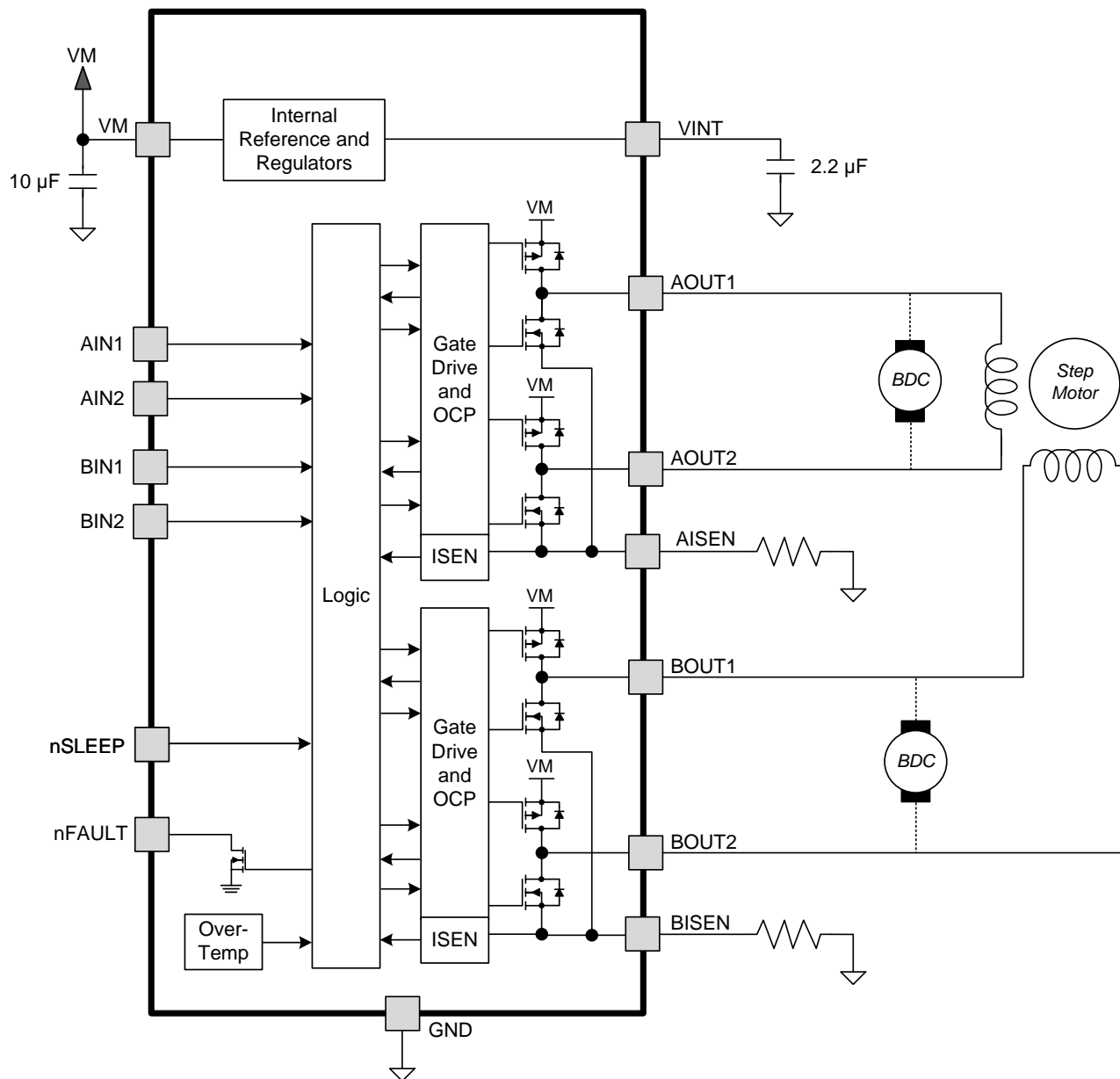

### 7.3 Feature Description

#### 7.3.1 PWM Motor Drivers

The DRV8833C contains drivers for two full H-bridges. Figure 6 shows a block diagram of the circuitry.

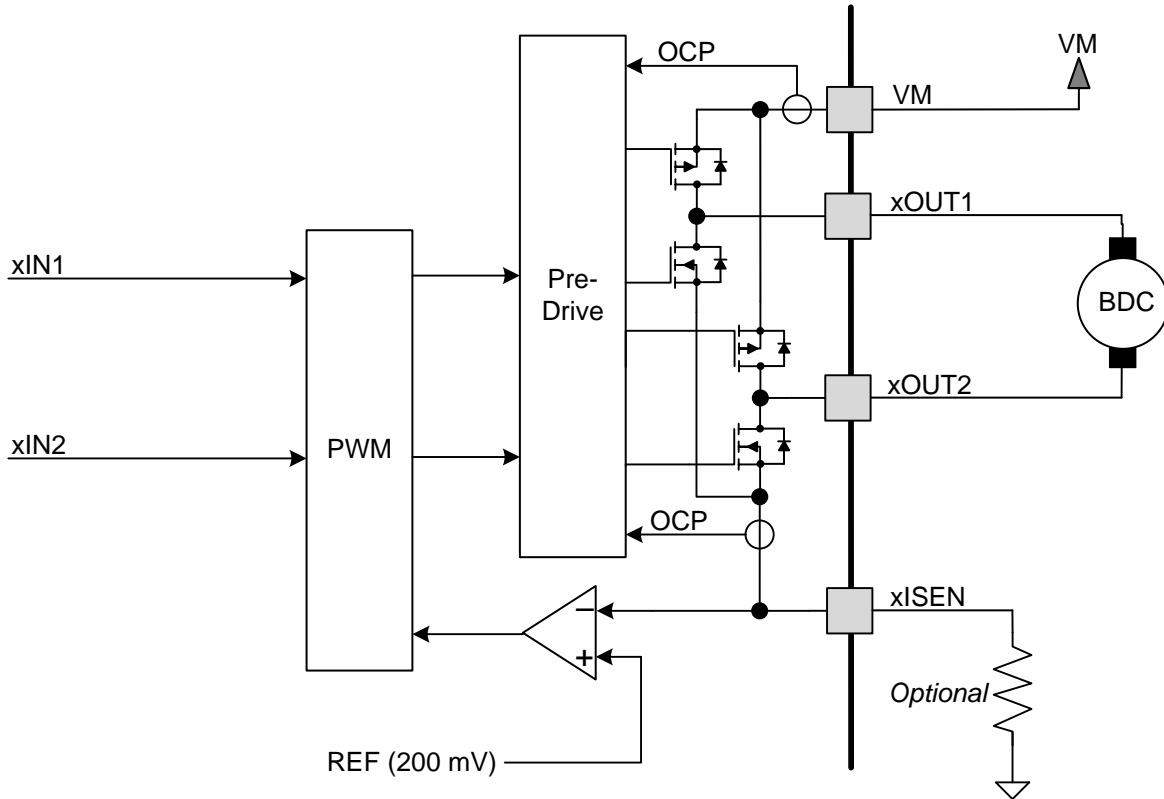

Figure 6. H-Bridge and Current-Chopping Circuitry

#### 7.3.2 Bridge Control and Decay Modes

The AIN1 and AIN2 input pins control the state of the AOUT1 and AOUT2 outputs; similarly, the BIN1 and BIN2 input pins control the state of the BOUT1 and BOUT2 outputs (see Table 1).

Table 1. H-Bridge Logic

xIN1	xIN2	xOUT1	xOUT2	FUNCTION
0	0	Z	Z	Coast / fast decay
0	1	L	H	Reverse
1	0	H	L	Forward
1	1	L	L	Brake / slow decay

The inputs can also be used for PWM control of the motor speed. When controlling a winding with PWM and the drive current is interrupted, the inductive nature of the motor requires that the current must continue to flow (called recirculation current). To handle this recirculation current, the H-bridge can operate in two different states, fast decay or slow decay. In fast-decay mode, the H-bridge is disabled and recirculation current flows through the body diodes. In slow-decay mode, the motor winding is shorted by enabling both low-side FETs.

To externally pulse-width modulate the bridge in fast-decay mode, the PWM signal is applied to one xIN pin while the other is held low; to use slow-decay mode, one xIN pin is held high. See Table 2 for more information.

**Table 2. PWM Control of Motor Speed**

xIN1	xIN2	FUNCTION
PWM	0	Forward PWM, fast decay
1	PWM	Forward PWM, slow decay
0	PWM	Reverse PWM, fast decay
PWM	1	Reverse PWM, slow decay

The internal current control is still enabled when applying external PWM to xIN. To disable the current control when applying external PWM, the xISEN pins should be connected directly to ground. Figure 7 show the current paths in different drive and decay modes.

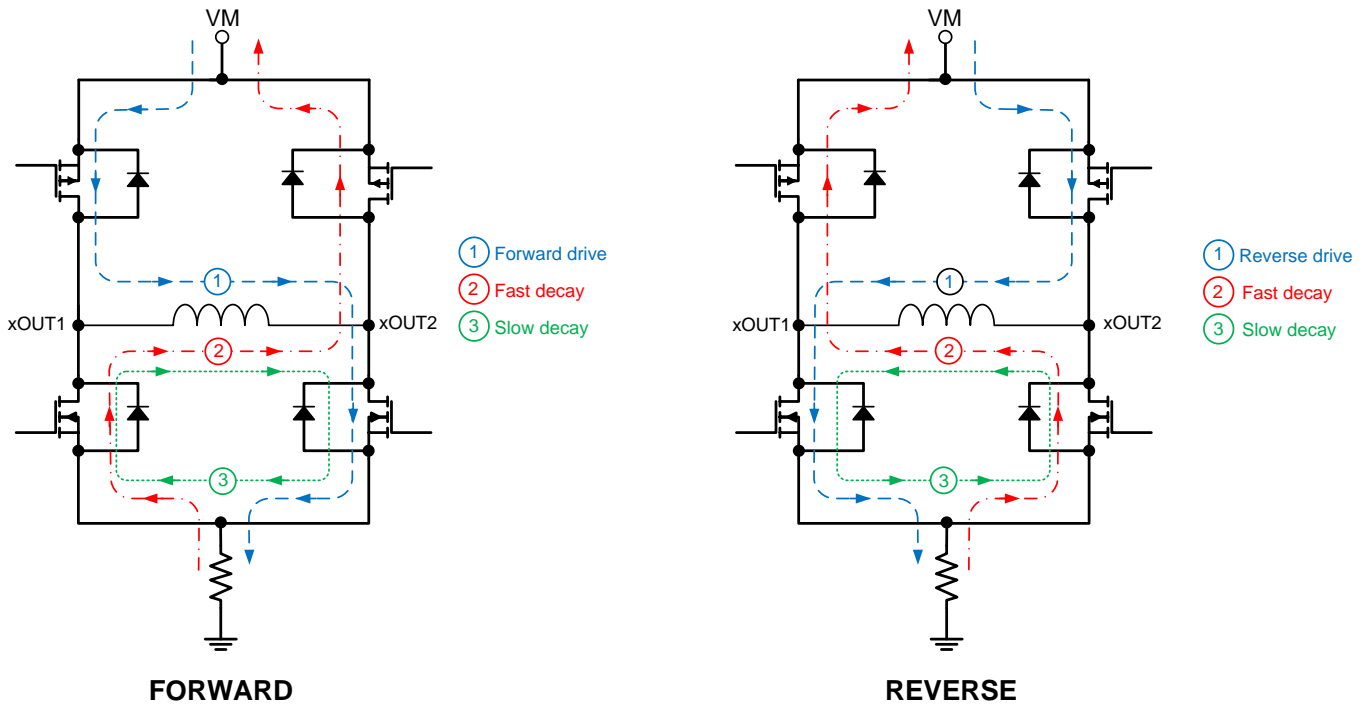

**Figure 7. Drive and Decay Modes**

**7.3.3 Current Control**

The current through the motor windings may be limited, or controlled, by a 20-μs constant off-time PWM current regulation, or current chopping. For DC motors, current control is used to limit the start-up and stall current of the motor. For stepper motors, current control is often used at all times.

When an H-bridge is enabled, current rises through the winding at a rate dependent on the DC voltage and inductance of the winding. If the current reaches the current chopping threshold, the bridge disables the current until the beginning of the next PWM cycle. Note that immediately after the output is enabled, the voltage on the xISEN pin is ignored for a fixed period of time before enabling the current sense circuitry. This blanking time is fixed at 3.75 μs.

The PWM chopping current is set by a comparator that compares the voltage across a current sense resistor connected to the xISEN pins with a reference voltage. The reference voltage, V<sub>TRIP</sub>, is fixed at 200 mV nominally.

The chopping current is calculated as in Equation 1.

$$I_{CHOP} = \frac{200 \text{ mV}}{R_{XISEN}} \tag{1}$$

Example: If a 1-Ω sense resistor is used, the chopping current will be 200 mV / 1 Ω = 200 mA.

**NOTE**

If current control is not needed, the xISEN pins should be connected directly to ground.

**7.3.4 Decay Mode**

After the chopping current threshold is reached, the H-bridge switches to slow-decay mode. This state is held for  $t_{off}$  (20  $\mu$ s) until the next cycle to turn on the high-side MOSFETs.

**7.3.5 Slow Decay**

In slow-decay mode, the high-side MOSFETs are turned off and both of the low-side MOSFETs are turned on. The motor current decreases while flowing in the two low-side MOSFETs until reaching its fixed off time (typically 20  $\mu$ s). After that, the high-side MOSFETs are enabled to increase the winding current again.

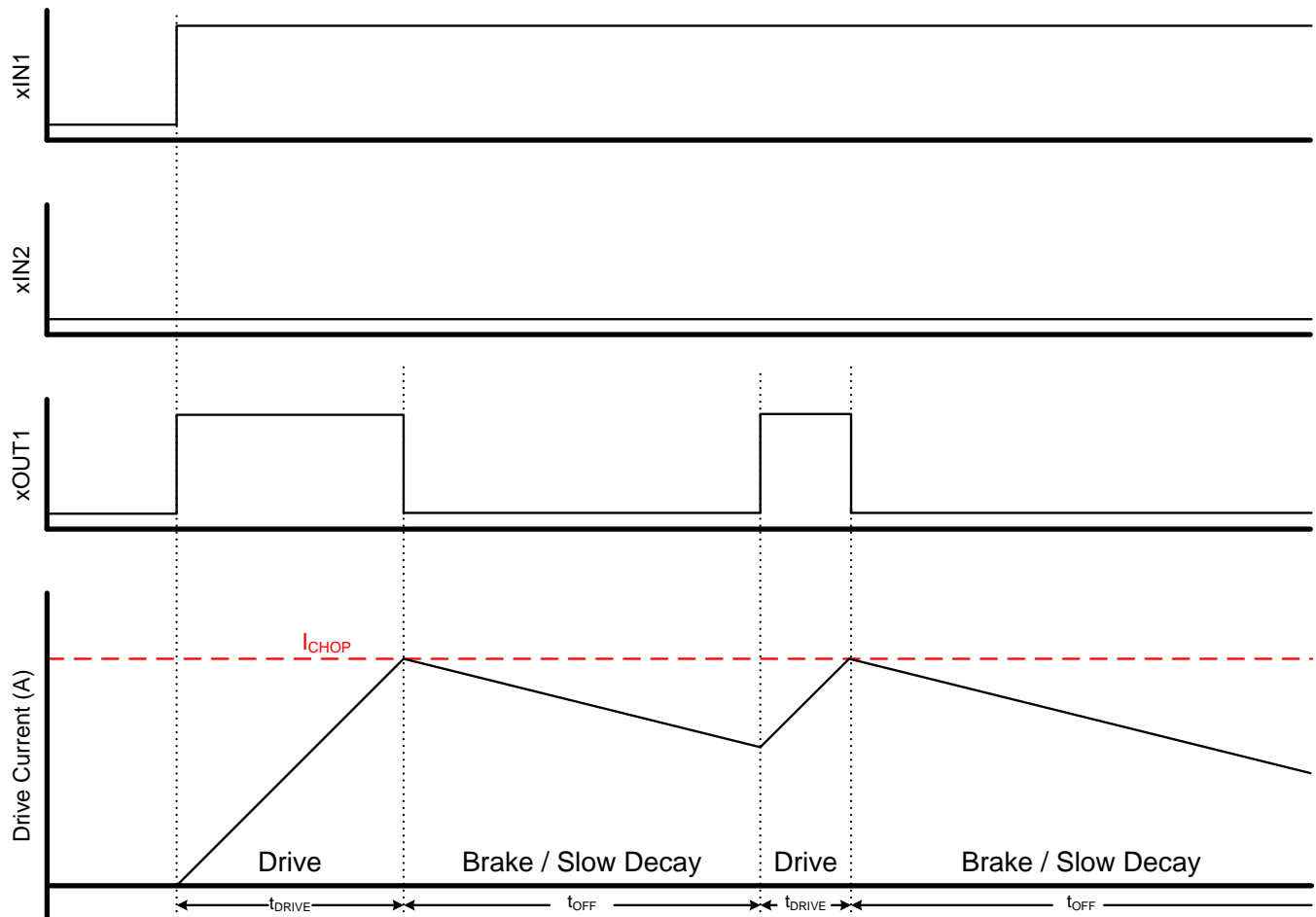

**Figure 8. Current Chopping Operation**

**7.3.6 Sleep Mode**

Driving nSLEEP low puts the device into a low-power sleep state. In this state, the H-bridges are disabled, all internal logic is reset, and all internal clocks are stopped. All inputs are ignored until nSLEEP returns inactive high. When returning from sleep mode, some time,  $t_{WAKE}$ , needs to pass before the motor driver becomes fully operational. To make the board design simple, the nSLEEP can be pulled up to the supply ( $V_M$ ). TI recommends to use a pullup resistor when this is done. This resistor limits the current to the input in case  $V_M$  is higher than 6.5 V. Internally, the nSLEEP pin has a 500-k $\Omega$  resistor to GND. It also has a clamping Zener diode that clamps the voltage at the pin at 6.5 V. Currents greater than 250  $\mu$ A can cause damage to the input structure. Therefore, TI recommends a pullup resistor between 20 to 75 k $\Omega$ .

### 7.3.7 Parallel Mode

The two H-bridges in the DRV8833C can be connected in parallel for double the current of a single H-bridge. The internal dead time in the DRV8833C prevents any risk of cross-conduction (shoot-through) between the two bridges due to timing differences between the two bridges. Figure 9 shows the connections.

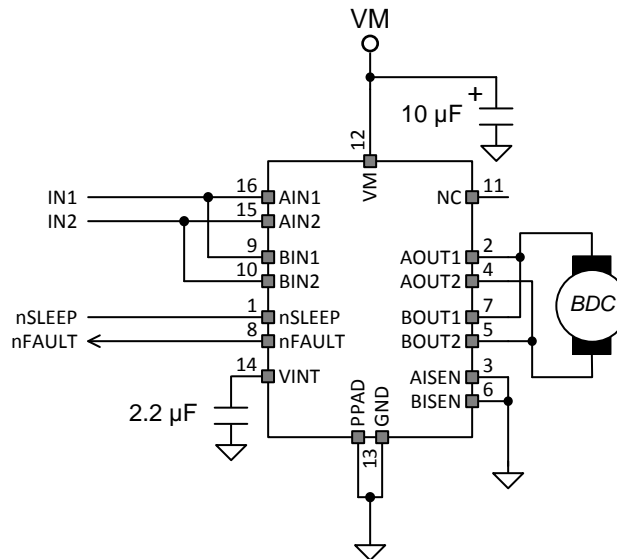

**Figure 9. Parallel Mode Schematic**

### 7.3.8 Protection Circuits

The DRV8833C is fully protected against overcurrent, overtemperature, and undervoltage events.

#### 7.3.8.1 Overcurrent Protection (OCP)

An analog current limit ( $I_{OCP}$ ) circuit on each FET limits the current through the FET by limiting the gate drive. If this analog current limit persists for longer than the OCP deglitch time ( $t_{DEG}$ ), all FETs in the H-bridge are disabled and the nFAULT pin is driven low. The driver is re-enabled after the OCP retry period ( $t_{OCP}$ ) has passed. nFAULT becomes high again after the retry time. If the fault condition is still present, the cycle repeats. If the fault is no longer present, normal operation resumes and nFAULT remains deasserted. Note that only the H-bridge in which the OCP is detected will be disabled while the other bridge functions normally.

Overcurrent conditions are detected independently on both high-side and low-side devices; a short to ground, supply, or across the motor winding all result in an overcurrent shutdown. Note that overcurrent protection does not use the current sense circuitry used for PWM current control, so it functions even without presence of the xISEN resistors.

#### 7.3.8.2 Thermal Shutdown (TSD)

If the die temperature exceeds safe limits, all FETs in the H-bridge are disabled and the nFAULT pin is driven low. After the die temperature has fallen below the specified hysteresis ( $T_{HYS}$ ), operation automatically resumes. The nFAULT pin is released after operation has resumed.

#### 7.3.8.3 UVLO

If at any time the voltage on the  $V_M$  pin falls below the UVLO threshold voltage,  $V_{UVLO}$ , all circuitry in the device is disabled, and all internal logic is reset. Operation resumes when  $V_M$  rises above the UVLO threshold. The nFAULT pin is not driven low during an undervoltage condition.

**Table 3. Device Protection**

Fault	Condition	Error Report	H-Bridge	Internal Circuits	Recovery
$V_M$ undervoltage (UVLO)	$V_M < 2.6\text{ V}$	None	Disabled	Disabled	$V_M > 2.7\text{ V}$
Overcurrent (OCP)	$I_{OUT} > I_{OCP}$	FAULTn	Disabled	Operating	OCP
Thermal Shutdown (TSD)	$T_J > T_{TSD}$	FAULTn	Disabled	Operating	$T_J < T_{TSD} - T_{HYS}$

## 7.4 Device Functional Modes

The DRV8833C is active unless the nSLEEP pin is brought logic low. In sleep mode, the H-bridge FETs are disabled (Hi-Z). Note that  $t_{SLEEP}$  must elapse after a falling edge on the nSLEEP pin before the device is in sleep mode. The DRV8833C is brought out of sleep mode automatically if nSLEEP is brought logic high. Note that  $t_{WAKE}$  must elapse before the outputs change state after wake-up.

**Table 4. Modes of Operation**

Fault	Condition	H-Bridge	Internal Circuits
Operating	nSLEEP pin high	Operating	Operating
Sleep mode	nSLEEP pin low	Disabled	Disabled
Fault encountered	Any fault condition met	Disabled	See <a href="#">Table 3</a>

## 8 Application and Implementation

### 8.1 Application Information

The DRV8833C is used in stepper or brushed DC motor control. The following design procedure can be used to configure the DRV8833C in a bipolar stepper motor application.

### 8.2 Typical Application

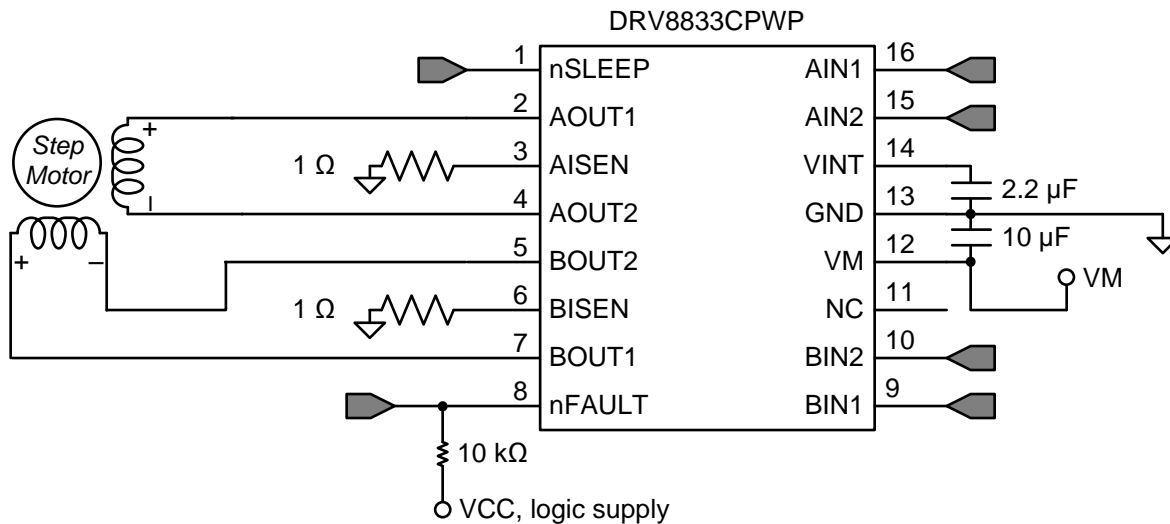

#### 8.2.1 Design Requirements

Table 5 gives design input parameters for system design.

**Table 5. Design Parameters**

Design Parameter	Reference	Example Value
Supply voltage	$V_M$	9 V
Motor winding resistance	$R_L$	12 $\Omega$ /phase
Motor winding inductance	$L_L$	10 mH/phase
Motor full step angle	$\theta_{\text{step}}$	1.8 $^\circ$ /step
Target stepping level	$n_m$	2 (half-stepping)
Target motor speed	$v$	120 rpm
Target chopping current	$I_{\text{CHOP}}$	200 mA
Sense resistor	$R_{\text{ISEN}}$	1 $\Omega$

#### 8.2.2 Detailed Design Procedure

##### 8.2.2.1 Stepper Motor Speed

The first step in configuring the DRV8833C requires the desired motor speed and stepping level. The DRV8833C can support full- and half-stepping modes using the PWM interface.

If the target motor speed is too high, the motor does not spin. Ensure that the motor can support the target speed.

For a desired motor speed ( $v$ ), microstepping level ( $n_m$ ), and motor full step angle ( $\theta_{\text{step}}$ ),

$$f_{\text{step}} \text{ (steps / s)} = \frac{v(\text{rpm}) \times n_m \text{ (steps)} \times 360^\circ / \text{rot}}{\theta_{\text{step}} \text{ (}^\circ / \text{step)} \times 60 \text{ s / min}} \quad (2)$$

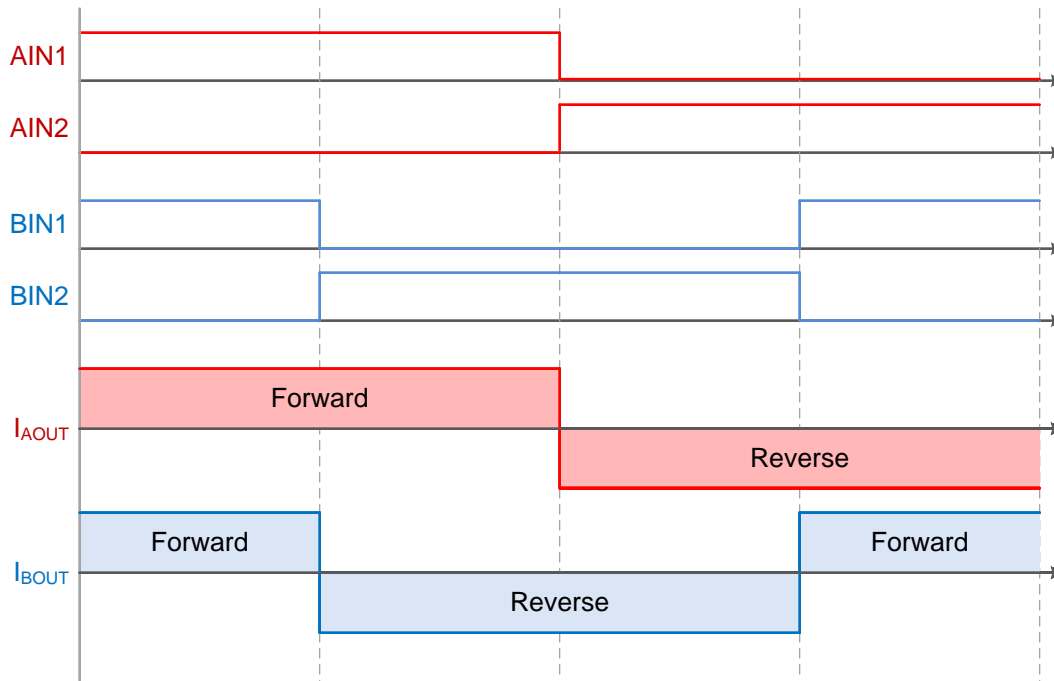

Figure 10. Full-Step Mode

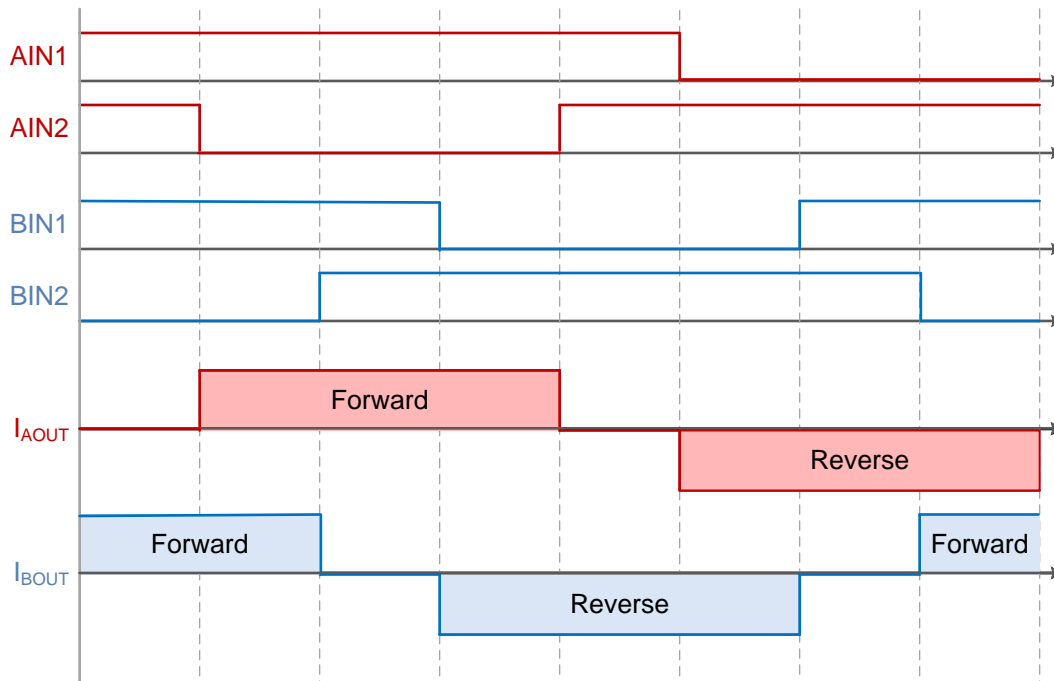

Figure 11. Half-Step Mode

### 8.2.2.2 Current Regulation

The chopping current ( $I_{CHOP}$ ) is the maximum current driven through either winding. This quantity depends on the sense resistor value ( $R_{XISEN}$ ).

$$I_{CHOP} = \frac{200 \text{ mV}}{R_{XISEN}}$$

(3)

$I_{\text{CHOP}}$  is set by a comparator which compares the voltage across  $R_{\text{XISEN}}$  to a reference voltage. Note that  $I_{\text{CHOP}}$  must follow Equation 4 to avoid saturating the motor.

$$I_{\text{FS}} (\text{A}) < \frac{V_{\text{M}} (\text{V})}{R_{\text{L}} (\Omega) + R_{\text{DS(ON)}} \text{HS} (\Omega) + R_{\text{DS(ON)}} \text{LS} (\Omega)}$$

where

- $V_{\text{M}}$  is the motor supply voltage.
- $R_{\text{L}}$  is the motor winding resistance.

(4)

### 8.2.3 Application Curve

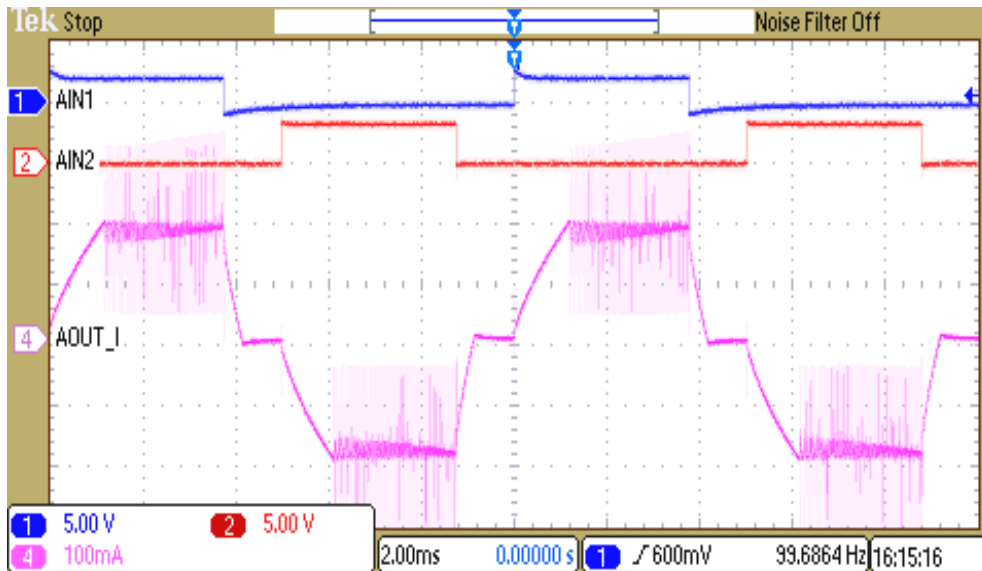

- A. Channel 1 is the AIN1 input PWM signal, and channel 2 is the AIN2 input PWM signal. BIN1 and BIN2 follow the same pattern, but are shifted by 90° from AIN1 and AIN2 as shown in Figure 11. Channel 4 is the output current in the direction AOUT1 → AOUT2. In forward and reverse drive, the current rises until it hits the current chopping limit of 200 mA, and is regulated at that level with fixed-off time current chopping.

**Figure 12. ½ Stepping Operation**

## 9 Power Supply Recommendations

The DRV8833C is designed to operate from an input voltage supply ( $V_M$ ) range between 2.7 to 10.8 V. A 10- $\mu$ F ceramic capacitor rated for  $V_M$  must be placed as close to the DRV8833C as possible.

### 9.1 Sizing Bulk Capacitance for Motor Drive Systems

Bulk capacitance sizing is an important factor in motor drive system design. It depends on a variety of factors including:

- Type of power supply
- Acceptable supply voltage ripple
- Parasitic inductance in the power supply wiring
- Type of motor (brushed DC, brushless DC, stepper)
- Motor startup current
- Motor braking method

The inductance between the power supply and motor drive system limits the rate current can change from the power supply. If the local bulk capacitance is too small, the system responds to excessive current demands or dumps from the motor with a change in voltage. Size the bulk capacitance to meet acceptable voltage ripple levels.

The data sheet generally provides a recommended value, but system-level testing is required to determine the appropriate-sized bulk capacitor.

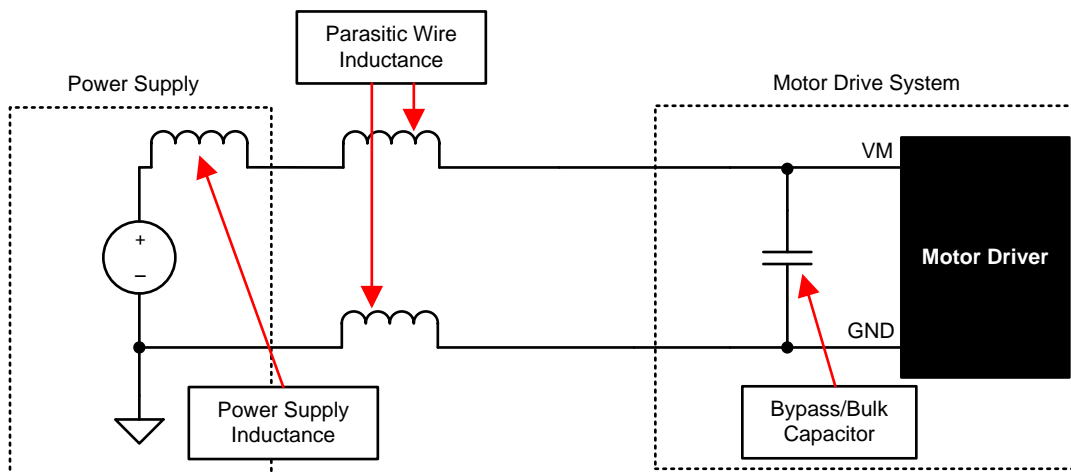

Figure 13. Setup of Motor Drive System With External Power Supply

## 10 Layout

### 10.1 Layout Guidelines

Bypass the  $V_M$  terminal to GND using a low-ESR ceramic bypass capacitor with a recommended value of  $10\ \mu\text{F}$  rated for  $V_M$ . This capacitor should be placed as close to the  $V_M$  pin as possible with a thick trace or ground plane connection to the device GND pin and PowerPAD.

Bypass VINT to ground with a ceramic capacitor rated 6.3 V. Place this bypassing capacitor as close to the pin as possible.

### 10.2 Layout Example

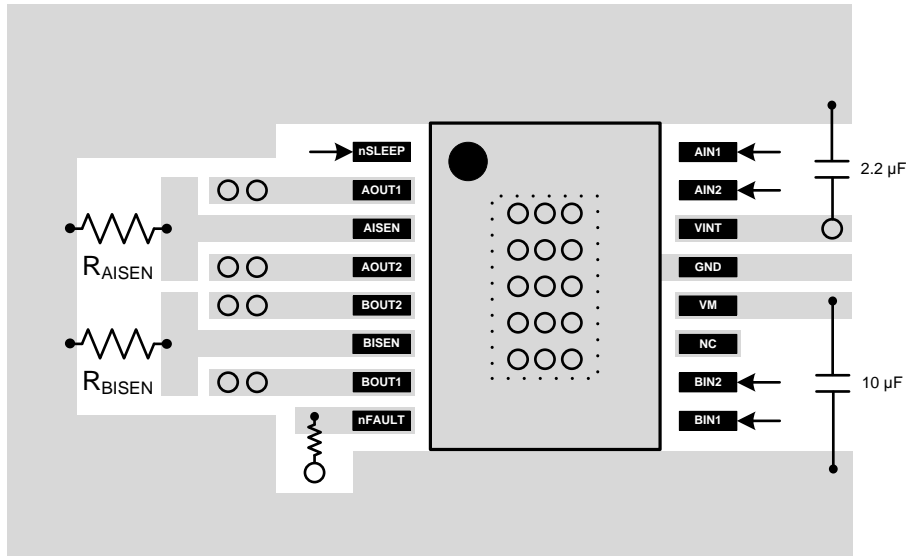

## 11 器件和文档支持

### 11.1 商标

PowerPAD is a trademark of Texas Instruments.

### 11.2 静电放电警告



这些装置包含有限的内置 ESD 保护。存储或装卸时，应将导线一起截短或将装置放置于导电泡棉中，以防止 MOS 门极遭受静电损伤。

### 11.3 术语表

[SLYZ022](#) — *TI* 术语表。

这份术语表列出并解释术语、首字母缩略词和定义。

## 12 机械封装和可订购信息

以下页中包括机械封装和可订购信息。 这些信息是针对指定器件可提供的最新数据。 这些数据会在无通知且不对本文档进行修订的情况下发生改变。 欲获得该数据表的浏览器版本，请查阅左侧的导航栏。

**PACKAGING INFORMATION**

Orderable Device	Status (1)	Package Type	Package Drawing	Pins	Package Qty	Eco Plan (2)	Lead finish/ Ball material (6)	MSL Peak Temp (3)	Op Temp (°C)	Device Marking (4/5)	Samples
DRV8833CPWP	ACTIVE	HTSSOP	PWP	16	90	RoHS & Green	NIPDAU	Level-3-260C-168 HR	-40 to 85	8833C	<a href="#">Samples</a>
DRV8833CPWPR	ACTIVE	HTSSOP	PWP	16	2000	RoHS & Green	NIPDAU	Level-3-260C-168 HR	-40 to 85	8833C	<a href="#">Samples</a>
DRV8833CRTER	ACTIVE	WQFN	RTE	16	3000	RoHS & Green	NIPDAU	Level-2-260C-1 YEAR	-40 to 85	8833C	<a href="#">Samples</a>
DRV8833CRTET	ACTIVE	WQFN	RTE	16	250	RoHS & Green	NIPDAU	Level-2-260C-1 YEAR	-40 to 85	8833C	<a href="#">Samples</a>

(1) The marketing status values are defined as follows:

**ACTIVE:** Product device recommended for new designs.

**LIFEBUY:** TI has announced that the device will be discontinued, and a lifetime-buy period is in effect.

**NRND:** Not recommended for new designs. Device is in production to support existing customers, but TI does not recommend using this part in a new design.

**PREVIEW:** Device has been announced but is not in production. Samples may or may not be available.

**OBSOLETE:** TI has discontinued the production of the device.

(2) **RoHS:** TI defines "RoHS" to mean semiconductor products that are compliant with the current EU RoHS requirements for all 10 RoHS substances, including the requirement that RoHS substance do not exceed 0.1% by weight in homogeneous materials. Where designed to be soldered at high temperatures, "RoHS" products are suitable for use in specified lead-free processes. TI may reference these types of products as "Pb-Free".

**RoHS Exempt:** TI defines "RoHS Exempt" to mean products that contain lead but are compliant with EU RoHS pursuant to a specific EU RoHS exemption.

**Green:** TI defines "Green" to mean the content of Chlorine (Cl) and Bromine (Br) based flame retardants meet JS709B low halogen requirements of <=1000ppm threshold. Antimony trioxide based flame retardants must also meet the <=1000ppm threshold requirement.

(3) MSL, Peak Temp. - The Moisture Sensitivity Level rating according to the JEDEC industry standard classifications, and peak solder temperature.

(4) There may be additional marking, which relates to the logo, the lot trace code information, or the environmental category on the device.

(5) Multiple Device Markings will be inside parentheses. Only one Device Marking contained in parentheses and separated by a "-" will appear on a device. If a line is indented then it is a continuation of the previous line and the two combined represent the entire Device Marking for that device.

(6) Lead finish/Ball material - Orderable Devices may have multiple material finish options. Finish options are separated by a vertical ruled line. Lead finish/Ball material values may wrap to two lines if the finish value exceeds the maximum column width.

**Important Information and Disclaimer:**The information provided on this page represents TI's knowledge and belief as of the date that it is provided. TI bases its knowledge and belief on information provided by third parties, and makes no representation or warranty as to the accuracy of such information. Efforts are underway to better integrate information from third parties. TI has taken and

continues to take reasonable steps to provide representative and accurate information but may not have conducted destructive testing or chemical analysis on incoming materials and chemicals. TI and TI suppliers consider certain information to be proprietary, and thus CAS numbers and other limited information may not be available for release.

In no event shall TI's liability arising out of such information exceed the total purchase price of the TI part(s) at issue in this document sold by TI to Customer on an annual basis.

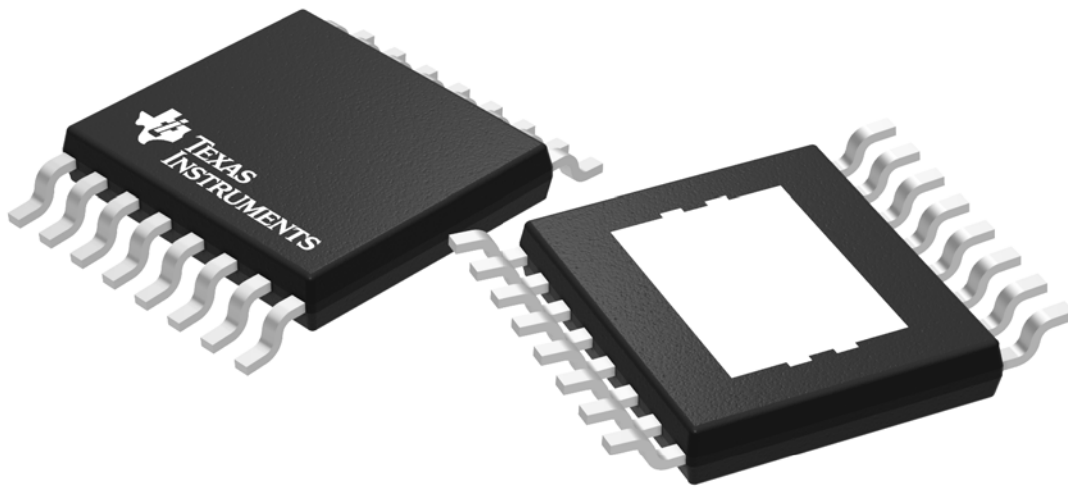

Images above are just a representation of the package family, actual package may vary.  
Refer to the product data sheet for package details.

# PWP0016C

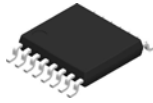

# PACKAGE OUTLINE

## PowerPAD™ TSSOP - 1.2 mm max height

SMALL OUTLINE PACKAGE

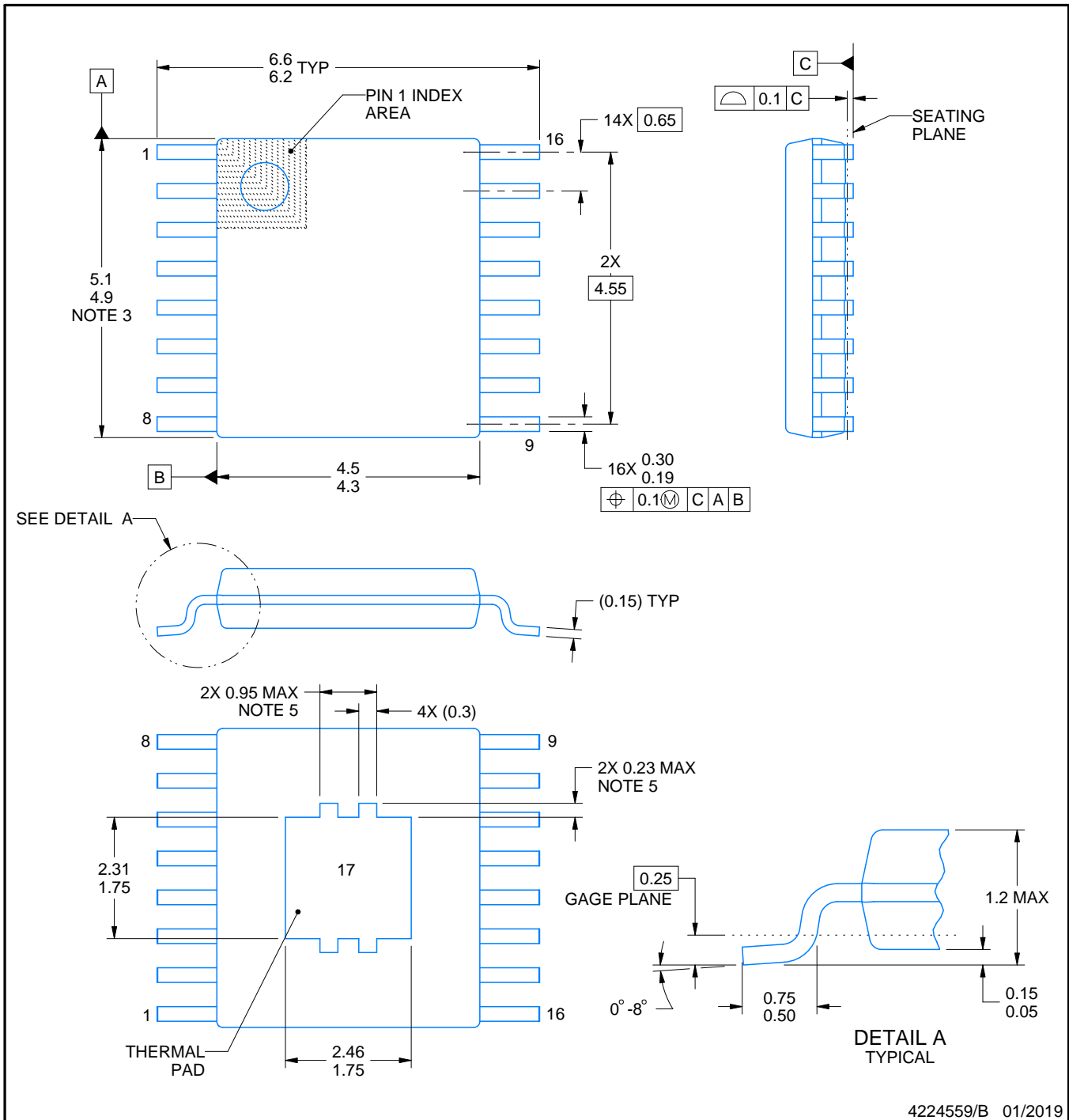

### NOTES:

PowerPAD is a trademark of Texas Instruments.

1. All linear dimensions are in millimeters. Any dimensions in parenthesis are for reference only. Dimensioning and tolerancing per ASME Y14.5M.
2. This drawing is subject to change without notice.
3. This dimension does not include mold flash, protrusions, or gate burrs. Mold flash, protrusions, or gate burrs shall not exceed 0.15 mm per side.
4. Reference JEDEC registration MO-153.
5. Features may differ or may not be present.

# EXAMPLE BOARD LAYOUT

PWP0016C

PowerPAD™ TSSOP - 1.2 mm max height

SMALL OUTLINE PACKAGE

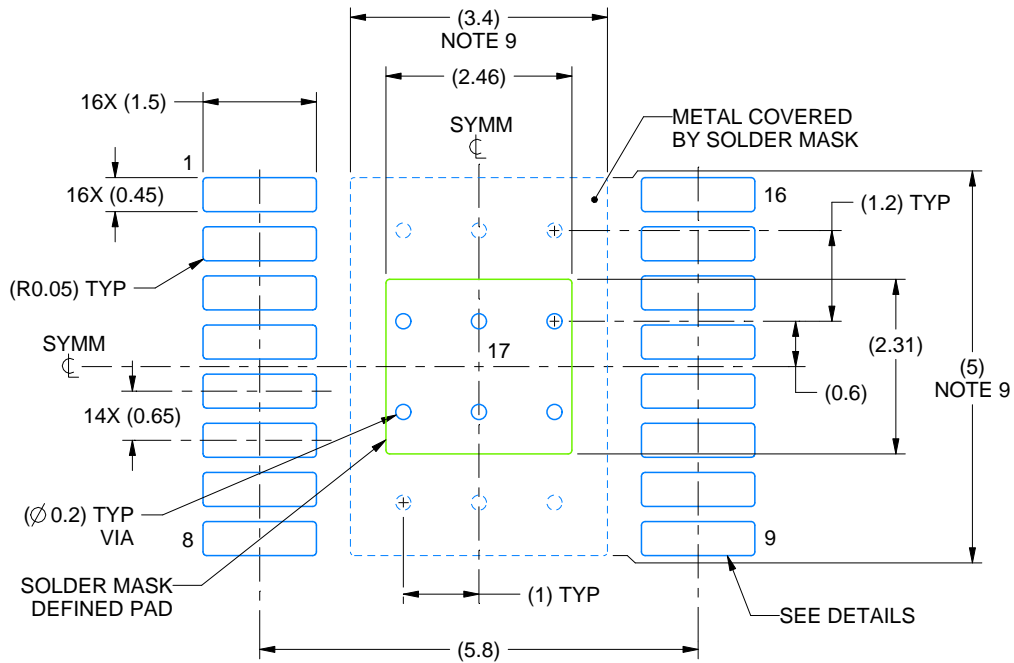

LAND PATTERN EXAMPLE  
EXPOSED METAL SHOWN  
SCALE: 10X

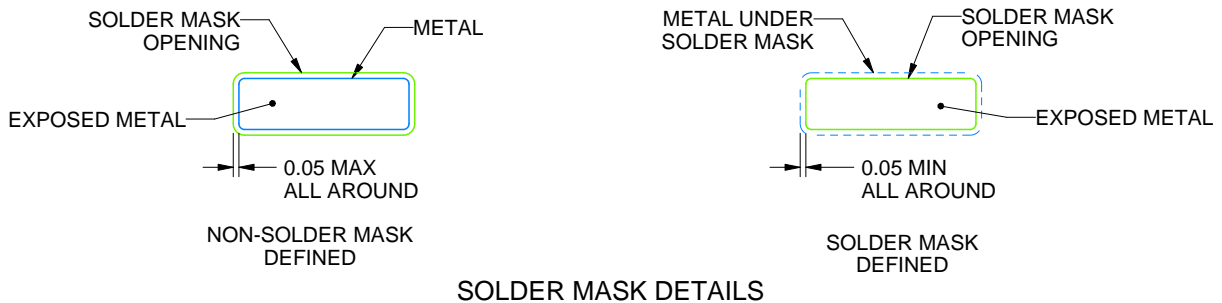

SOLDER MASK DETAILS

4224559/B 01/2019

NOTES: (continued)

6. Publication IPC-7351 may have alternate designs.
7. Solder mask tolerances between and around signal pads can vary based on board fabrication site.
8. This package is designed to be soldered to a thermal pad on the board. For more information, see Texas Instruments literature numbers SLMA002 ([www.ti.com/lit/slma002](http://www.ti.com/lit/slma002)) and SLMA004 ([www.ti.com/lit/slma004](http://www.ti.com/lit/slma004)).
9. Size of metal pad may vary due to creepage requirement.
10. Vias are optional depending on application, refer to device data sheet. It is recommended that vias under paste be filled, plugged or tented.

# EXAMPLE STENCIL DESIGN

PWP0016C

PowerPAD™ TSSOP - 1.2 mm max height

SMALL OUTLINE PACKAGE

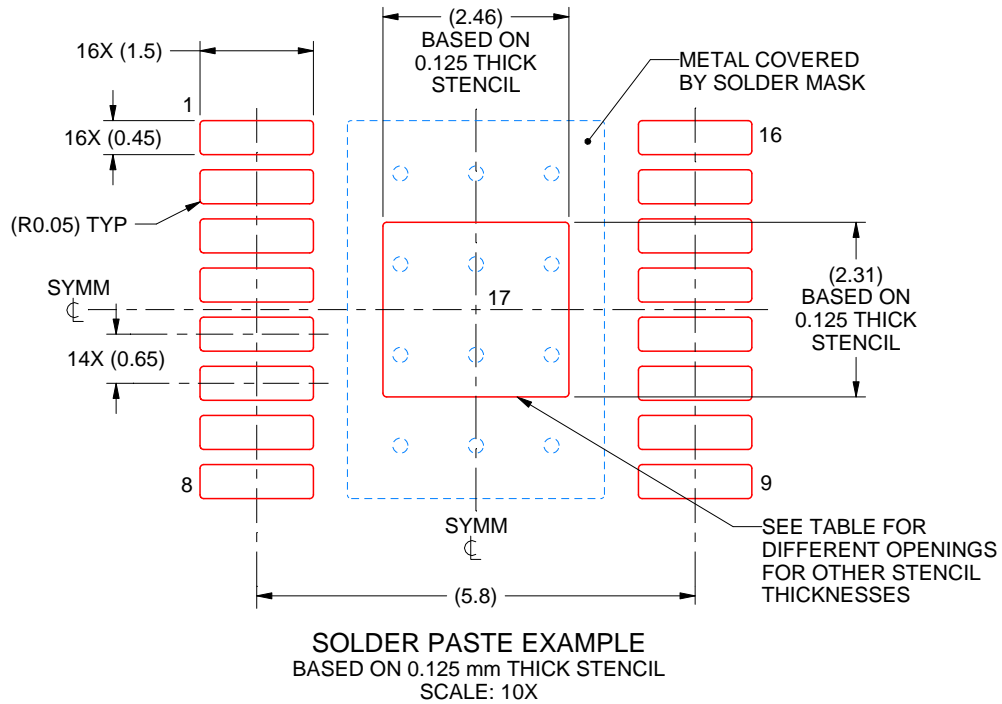

STENCIL THICKNESS	SOLDER STENCIL OPENING
0.1	2.75 X 2.58
0.125	2.46 X 2.31 (SHOWN)
0.15	2.25 X 2.11
0.175	2.08 X 1.95

4224559/B 01/2019

NOTES: (continued)

11. Laser cutting apertures with trapezoidal walls and rounded corners may offer better paste release. IPC-7525 may have alternate design recommendations.
12. Board assembly site may have different recommendations for stencil design.

## GENERIC PACKAGE VIEW

**RTE 16**

**WQFN - 0.8 mm max height**

3 x 3, 0.5 mm pitch

PLASTIC QUAD FLATPACK - NO LEAD

This image is a representation of the package family, actual package may vary.  
Refer to the product data sheet for package details.

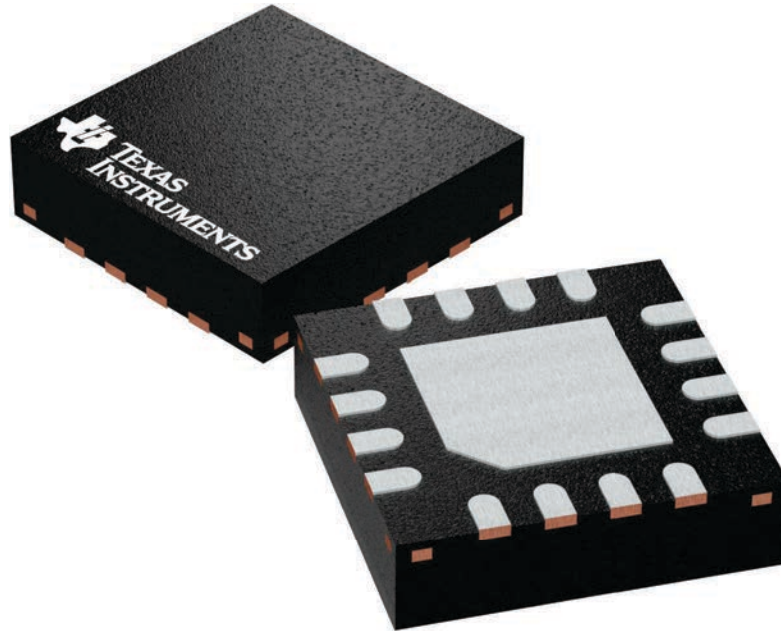

4225944/A



# EXAMPLE BOARD LAYOUT

RTE0016C

WQFN - 0.8 mm max height

PLASTIC QUAD FLATPACK - NO LEAD

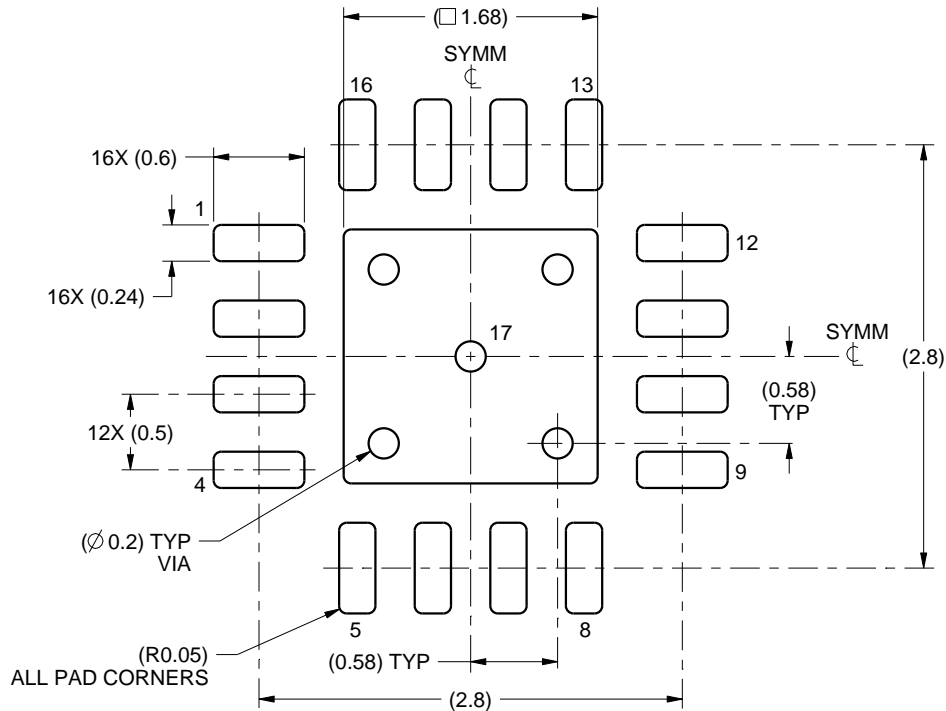

LAND PATTERN EXAMPLE  
SCALE:20X

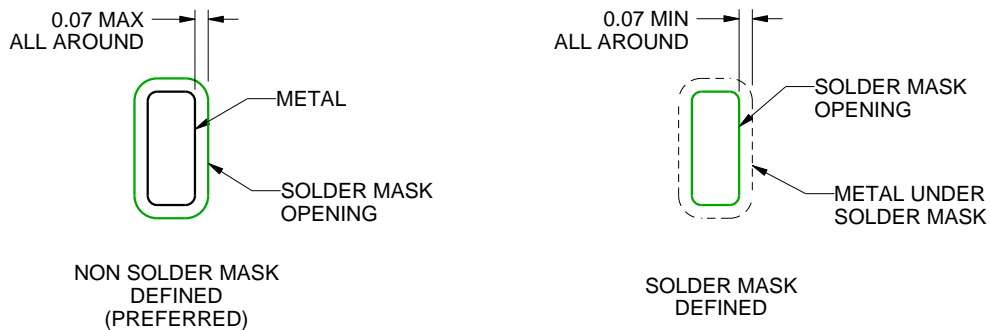

SOLDER MASK DETAILS

4219117/A 09/2016

NOTES: (continued)

4. This package is designed to be soldered to a thermal pad on the board. For more information, see Texas Instruments literature number SLUA271 ([www.ti.com/lit/slua271](http://www.ti.com/lit/slua271)).
5. Vias are optional depending on application, refer to device data sheet. If any vias are implemented, refer to their locations shown on this view. It is recommended that vias under paste be filled, plugged or tented.

# EXAMPLE STENCIL DESIGN

RTE0016C

WQFN - 0.8 mm max height

PLASTIC QUAD FLATPACK - NO LEAD

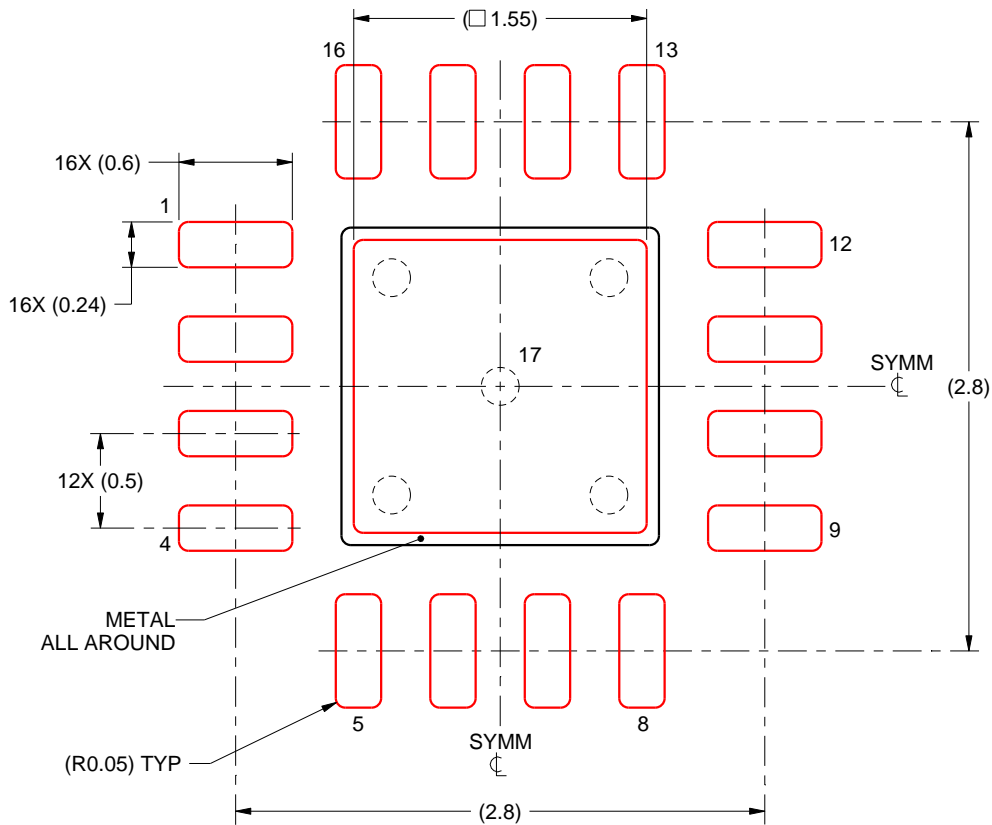

**SOLDER PASTE EXAMPLE**  
BASED ON 0.125 mm THICK STENCIL

EXPOSED PAD 17:  
85% PRINTED SOLDER COVERAGE BY AREA UNDER PACKAGE  
SCALE:25X

4219117/A 09/2016

NOTES: (continued)

6. Laser cutting apertures with trapezoidal walls and rounded corners may offer better paste release. IPC-7525 may have alternate design recommendations.

## 重要声明和免责声明

TI“按原样”提供技术和可靠性数据（包括数据表）、设计资源（包括参考设计）、应用或其他设计建议、网络工具、安全信息和其他资源，不保证没有瑕疵且不做任何明示或暗示的担保，包括但不限于对适销性、某特定用途方面的适用性或不侵犯任何第三方知识产权的暗示担保。

这些资源可供使用 TI 产品进行设计的熟练开发人员使用。您将自行承担以下全部责任：(1) 针对您的应用选择合适的 TI 产品，(2) 设计、验证并测试您的应用，(3) 确保您的应用满足相应标准以及任何其他功能安全、信息安全、监管或其他要求。

这些资源如有变更，恕不另行通知。TI 授权您仅可将这些资源用于研发本资源所述的 TI 产品的应用。严禁对这些资源进行其他复制或展示。您无权使用任何其他 TI 知识产权或任何第三方知识产权。您应全额赔偿因在这些资源的使用中对 TI 及其代表造成的任何索赔、损害、成本、损失和债务，TI 对此概不负责。

TI 提供的产品受 [TI 的销售条款](#) 或 [ti.com](#) 上其他适用条款/TI 产品随附的其他适用条款的约束。TI 提供这些资源并不会扩展或以其他方式更改 TI 针对 TI 产品发布的适用的担保或担保免责声明。

TI 反对并拒绝您可能提出的任何其他或不同的条款。

邮寄地址：Texas Instruments, Post Office Box 655303, Dallas, Texas 75265

Copyright © 2022，德州仪器 (TI) 公司