



Dual 14 BIT, 65 MSPS™ Analog-to-Digital Converter

FEATURES

- Dual ADC
- 14 Bit Resolution
- 65 MSPS Sample Rate
- High SNR = 74 dBFS at 70 MHz f_{IN}
- High SFDR = 84 dBc at 70 MHz f_{IN}
- 2.3 V_{PP} Differential Input Voltage
- Internal / External Voltage Reference
- 3.3 V Single-Supply Voltage

- Analog Power Dissipation = 0.72 W
- Output Supply Power Dissipation = 0.17 W
- 80 Lead PowerPad™ TQFP Package
- Two's Complement Output Format

APPLICATIONS

- Communication Receivers
- Base Station Infrastructure
- Test and Measurement Instrumentation

DESCRIPTION

The ADS5553 is a high-performance, dual channel, 14 bit, 65 MSPS analog-to-digital converter (ADC). To provide a complete solution, each channel includes a high-bandwidth linear sample-and-hold stage (S&H) and an internal reference. Designed for applications demanding high dynamic performance in a small space, the ADS5553 has excellent power consumption of 0.9 W at 3.3 V single-supply voltage. This allows an even higher system integration density. The provided internal reference simplifies system design requirements, yet an external reference can be used optionally to suit the accuracy and low drift requirements of the application. The outputs are parallel CMOS compatible.

The ADS5553 is available in a 80 lead TQFP PowerPAD package and is specified over the full temperature range of -40°C to 85°C.

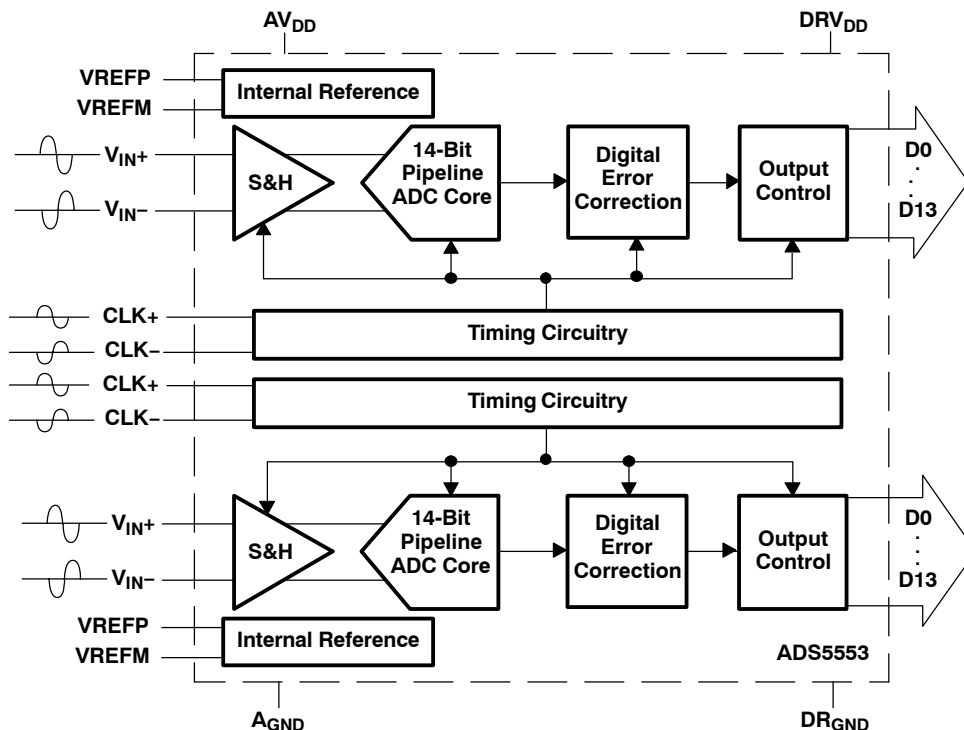

Please be aware that an important notice concerning availability, standard warranty, and use in critical applications of Texas Instruments semiconductor products and disclaimers thereto appears at the end of this data sheet.

CommsADC is a trademark of Texas Instruments.

PACKAGE/ORDERING INFORMATION⁽¹⁾

PRODUCT	PACKAGE-LEAD	PACKAGE DESIGNATOR	SPECIFIED TEMPERATURE RANGE	PACKAGE MARKING	ORDERING NUMBER	TRANSPORT MEDIA, QUANTITY
ADS5553	HTQFP-80 ⁽²⁾ PowerPAD	PFP	-40°C to 85°C	ADS5553I	ADS5553IPFP	Tray, 96
					ADS5553IPFPR	Tape and Reel, 1000

⁽¹⁾ For the most current product and ordering information, see the Package Option Addendum located at the end of this data sheet.

⁽²⁾ Thermal pad size: 6.17 mm x 6.17 mm (min), 7.5 mm x 7.5 mm (max). $\theta_{ja} = 21^\circ\text{C/W}$ (no airflow) or 15°C/W (with 200 LPFM airflow), $\theta_{jc} = 13.5^\circ\text{C/W}$, and θ_{jp} (to the bottom PowerPad) = 2°C/W when used with 2 oz. copper trace and pad soldered directly to a JEDEC standard four layer 3 in x 3 in PCB.

ABSOLUTE MAXIMUM RATINGS

over operating free-air temperature range unless otherwise noted⁽¹⁾

		ADS5553	UNIT
Supply Voltage	AV_{DD} to A_{GND} , DRV_{DD} to DR_{GND}	-0.3 to 3.7	V
	A_{GND} to DR_{GND}	± 0.1	V
Analog input to A_{GND} ⁽²⁾		-0.3 to 3.6	V
Logic input to DR_{GND}		-0.3 to $DRV_{DD} + 0.3$	V
Digital data output to DR_{GND}		-0.3 to $DRV_{DD} + 0.3$	V
Operating temperature range		-40 to 85	°C
Junction temperature		105	°C
Storage temperature range		-65 to 150	°C

⁽¹⁾ Stresses above these ratings may cause permanent damage. Exposure to absolute maximum conditions for extended periods may degrade device reliability. These are stress ratings only, and functional operation of the device at these or any other conditions beyond those specified is not implied.

⁽²⁾ For more details, see the *Input Voltage Overstress* section in this data sheet.



This integrated circuit can be damaged by ESD. Texas Instruments recommends that all integrated circuits be handled with appropriate precautions. Failure to observe

proper handling and installation procedures can cause damage.

ESD damage can range from subtle performance degradation to complete device failure. Precision integrated circuits may be more susceptible to damage because very small parametric changes could cause the device not to meet its published specifications.

RECOMMENDED OPERATING CONDITIONS

PARAMETER	MIN	TYP	MAX	UNIT
Supplies				
Analog supply voltage, AV_{DD}	3	3.3	3.6	V
Output driver supply voltage, DRV_{DD}	3	3.3	3.6	V
Analog Input				
Differential input range	2.3			V_{PP}
Input common-mode voltage, V_{CM} ⁽¹⁾	1.45	1.55	1.65	V
Digital Output				
Maximum output load	10			pF
Clock Input				
ADCLK input sample rate (sine wave) $1/t_C$	10		65	MSPS
Clock amplitude, sine wave, differential ⁽²⁾	3			V_{PP}
Clock duty cycle ⁽³⁾	50%			
Open free-air temperature range	-40		85	°C

⁽¹⁾ Input common-mode should be connected to CM.

⁽²⁾ See Figure 20 for more information.

⁽³⁾ See Figure 21 for more information.

ELECTRICAL CHARACTERISTICS

Typ, min, and max values at $T_A = 25^\circ\text{C}$, full temperature range is $T_{\text{MIN}} = -40^\circ\text{C}$ to $T_{\text{MAX}} = 85^\circ\text{C}$, sampling rate = 65 MSPS, 50% clock duty cycle, $AV_{\text{DD}} = DRV_{\text{DD}} = 3.3\text{ V}$, -1-dBFS differential input, $3\text{-}V_{\text{PP}}$ differential clock, and internal reference, unless otherwise noted

PARAMETER	CONDITIONS	MIN	TYP	MAX	UNIT	
Resolution			14		Bits	
Analog Inputs						
Differential input range			2.3		V_{PP}	
Differential input capacitance	See Figure 28		3.2		pF	
Total analog input common-mode current			200 ⁽¹⁾		μA	
Analog input bandwidth	Source impedance = $50\ \Omega$		750		MHz	
Internal Reference Voltages						
Reference bottom voltage, V_{REFM}			1.01		V	
Reference top voltage, V_{REFP}			2.16		V	
Total gain error ⁽²⁾			± 3.5		%FS	
Common-mode voltage output, V_{CM}			1.57		V	
Dynamic Linearity and Accuracy						
No missing codes			Tested			
Differential linearity error, DNL	$f_{\text{IN}} = 46\text{ MHz}$	-0.95	± 0.6	1	LSB	
Integral linearity error, INL	$f_{\text{IN}} = 46\text{ MHz}$	-4	± 2.5	4	LSB	
Offset error			± 4		mV	
Offset temperature coefficient			7		$\mu\text{V}/^\circ\text{C}$	
Offset matching			± 0.7		mV	
Gain error ⁽³⁾			± 0.5		%FS	
Gain temperature coefficient ⁽³⁾			0.0015		$\Delta\%/^\circ\text{C}$	
Gain matching ⁽³⁾			± 0.1		%FS	
Dynamic AC Characteristics						
Signal-to-noise ratio, SNR	$f_{\text{IN}} = 10\text{ MHz}$		74.4		dBFS	
	$f_{\text{IN}} = 46\text{ MHz}$		74			
	$f_{\text{IN}} = 70\text{ MHz}$	25°C to 85°C	72.4	74		
		Full temp range	71.4	74		
	$f_{\text{IN}} = 100\text{ MHz}$		73.5			
	$f_{\text{IN}} = 150\text{ MHz}$		72.5			
$f_{\text{IN}} = 225\text{ MHz}$		71				
RMS output noise	Input tied to common-mode		1		LSB	
Spurious-free dynamic range, SFDR	$f_{\text{IN}} = 10\text{ MHz}$		85		dBc	
	$f_{\text{IN}} = 46\text{ MHz}$		84			
	$f_{\text{IN}} = 70\text{ MHz}$	Room temp	80	84		
		Full temp range	78	83		
	$f_{\text{IN}} = 100\text{ MHz}$		83			
	$f_{\text{IN}} = 150\text{ MHz}$		81			
$f_{\text{IN}} = 225\text{ MHz}$		75				

⁽¹⁾ 100- μA per input

⁽²⁾ Includes error due to references. The total gain error will become smaller (see gain error in the *Dynamic Linearity and Accuracy* section of this table) if an external reference is used.

⁽³⁾ Gain error left assuming ideal references: $V_{\text{REFP}} - V_{\text{REFM}} = 1.15\text{ V}$

ELECTRICAL CHARACTERISTICS

Typ, min, and max values at T_A = 25°C, full temperature range is T_{MIN} = -40°C to T_{MAX} = 85°C, sampling rate = 65 MSPS, 50% clock duty cycle, AV_{DD} = DRV_{DD} = 3.3 V, -1-dBFS differential input, 3-V_{PP} differential clock, and internal reference, unless otherwise noted

PARAMETER	CONDITIONS	MIN	TYP	MAX	UNIT	
Second-harmonic, HD2	f _{IN} = 10 MHz		93		dBc	
	f _{IN} = 46 MHz		93			
	f _{IN} = 70 MHz	Room temp	80	86		
		Full temp range	78	85		
	f _{IN} = 100 MHz		86			
	f _{IN} = 150 MHz		82			
f _{IN} = 225 MHz		79				
Third-harmonic, HD3	f _{IN} = 10 MHz		85		dBc	
	f _{IN} = 46 MHz		84			
	f _{IN} = 70 MHz	Room temp	80	84		
		Full temp range	78	83		
	f _{IN} = 100 MHz		83			
	f _{IN} = 150 MHz		81			
f _{IN} = 225 MHz		75				
Worst-harmonic/spur (other than HD2 and HD3)	f _{IN} = 10 MHz	Room temp	86		dBc	
	f _{IN} = 70 MHz	Room temp	85			
Signal-to-noise + distortion, SINAD	f _{IN} = 10 MHz		74		dBFS	
	f _{IN} = 46 MHz		73.5			
	f _{IN} = 70 MHz	25°C to 85°C	71.8	73.4		
		Full temp range	71	73		
	f _{IN} = 100 MHz		73			
	f _{IN} = 150 MHz		71.8			
f _{IN} = 225 MHz		69.5				
Total harmonic distortion, THD	f _{IN} = 10 MHz		83		dBc	
	f _{IN} = 46 MHz		82			
	f _{IN} = 70 MHz	Room temp	82			
		Full temp range	82			
	f _{IN} = 100 MHz		81			
	f _{IN} = 150 MHz		81			
f _{IN} = 225 MHz		74				
Effective number of bits, ENOB	f _{IN} = 70 MHz		11.9		Bits	
Two-tone intermodulation distortion, IMD3	f = 10.1 MHz, 15.1 MHz (-7dBFS each tone)		94		dBc	
	f = 48 MHz, 53 MHz (-7 dBFS each tone)		84			
	f = 147 MHz, 152 MHz (-7 dBFS each tone)		75			
Crosstalk	f _{IN} = 70 MHz ⁽⁴⁾		-100	-95	dBc	

⁽⁴⁾ Inject one tone at -1 dBFS on one channel and measure the amplitude on the other channel, then repeat for the other channel

ELECTRICAL CHARACTERISTICS

Typ, min, and max values at $T_A = 25^\circ\text{C}$, full temperature range is $T_{\text{MIN}} = -40^\circ\text{C}$ to $T_{\text{MAX}} = 85^\circ\text{C}$, sampling rate = 65 MSPS, 50% clock duty cycle, $AV_{\text{DD}} = DRV_{\text{DD}} = 3.3\text{ V}$, -1-dBFS differential input, 3- V_{PP} differential clock, and internal reference, unless otherwise noted

PARAMETER	CONDITIONS	MIN	TYP	MAX	UNIT
Power Supply					
Total supply current, I_{CC}	$V_{\text{IN}} = \text{full-scale}$, $f_{\text{IN}} = 70\text{ MHz}$		270	288	mA
Analog supply current, I_{AVDD}	$V_{\text{IN}} = \text{full-scale}$, $f_{\text{IN}} = 70\text{ MHz}$		220	230	mA
Output buffer supply current, I_{DRVDD}	$V_{\text{IN}} = \text{full-scale}$, $f_{\text{IN}} = 70\text{ MHz}$, with 10 pF load on digital outputs to ground		50	58	mA
Power dissipation	Analog only, $f_{\text{IN}} = 70\text{ MHz}$		725	760	mW
	Digital power with 10-pF load on digital outputs to ground, $f_{\text{IN}} = 70\text{ MHz}$		165	190	
Power dissipation with external reference	Total power with 10-pF load on digital outputs to ground, $f_{\text{IN}} = 70\text{ MHz}$		780	820	mW
Standby power	With clocks running (both channels off and outputs disabled)		220	250	mW

DIGITAL CHARACTERISTICS

Typ, min, and max values at $T_A = 25^\circ\text{C}$, full temperature range is $T_{\text{MIN}} = -40^\circ\text{C}$ to $T_{\text{MAX}} = 85^\circ\text{C}$, and $AV_{\text{DD}} = DRV_{\text{DD}} = 3.3\text{ V}$, unless otherwise noted

PARAMETER	CONDITIONS	MIN	TYP	MAX	UNIT
Digital Inputs					
High-level input voltage		2.4			V
Low-level input voltage				0.8	V
High-level input current				10	μA
Low-level input current				10	μA
Input capacitance			4		pF
Digital Outputs⁽¹⁾					
Low-level output voltage	$C_{\text{LOAD}} = 10\text{ pF}^{(2)}$		0.3	0.4	V
High-level output voltage	$C_{\text{LOAD}} = 10\text{ pF}^{(2)}$	2.8	3		V
Output capacitance			3		pF

(1) For optimal performance, all digital output lines (D0:D13), including the output clock, should see a similar load.

(2) Equivalent capacitance to ground of (load + parasitics of transmission lines).

TIMING CHARACTERISTICS

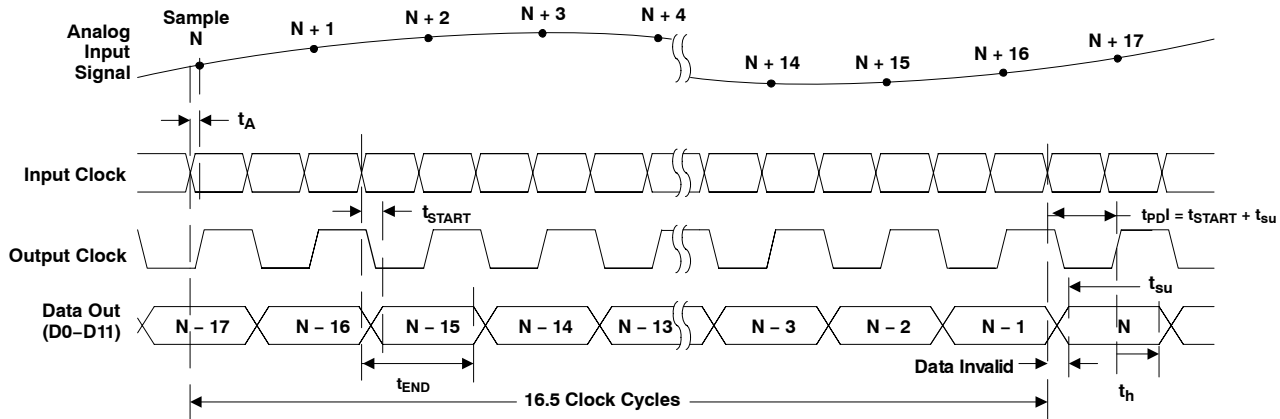

NOTE: It is recommended that the loading at CLKOUT and all data lines are accurately matched to ensure that the above timing matches closely with the specified values.

Figure 1. Timing Diagram

TIMING CHARACTERISTICS⁽³⁾

Over full temperature range ($T_{MIN} = -40^{\circ}C$ to $T_{MAX} = +85^{\circ}C$), sampling rate = 65 MSPS, 50% clock duty cycle, and $AV_{DD} = DRV_{DD} = 3.3 V$, unless otherwise noted

PARAMETER	DESCRIPTION	MIN	TYP	MAX	UNIT
Switching Specification					
Aperture delay, t_A	Input CLK falling edge to data sampling point		1		ns
Aperture delay matching, t_A	Channel-to-channel aperture delay matching		50		ps
Aperture jitter (uncertainty)	Uncertainty in sampling instant		300		fs
Latency			16.5		Clock Cycles
Data setup time, t_{SU}	Data valid ⁽¹⁾ to 50% of CLKOUT rising edge	4.3	6		ns
Data hold time, t_H	50% of CLKOUT rising edge to data becoming invalid ⁽¹⁾	2	2.8		ns
Data start time, t_{START}	50% of clock input to beginning of valid data ⁽¹⁾		2.5	4.5	ns
Data stop time, t_{END}	50% of clock input to end of valid data ⁽¹⁾	9	10.6		ns
Data rise time, t_r	Data rise time measured from 20% to 80% of DRV_{DD}		6.6		ns
Data fall time, t_f	Data fall time measured from 80% to 20% of DRV_{DD}		5.5		ns
Data setup time, t_{SU}	Data valid ⁽¹⁾ to 50% of CLKOUT rising edge, $f_S = 40$ MSPS	8.5	11		ns
Data hold time, t_H	50% of CLKOUT rising edge to data becoming invalid ⁽¹⁾ , $f_S = 40$ MSPS	2.6	4		ns
Data start time, t_{START}	50% of clock input to beginning of valid data ⁽¹⁾ , $F_S = 40$ MSPS		-2.5	1	ns
Data stop time, t_{END}	50% of clock input to end of valid data ⁽¹⁾ , $F_S = 40$ MSPS	11.5	13		ns
Data rise time, t_r	Data rise time measured from 20% to 80% of DRV_{DD} , $f_S = 40$ MSPS		7.5		ns
Data fall time, t_f	Data fall time measured from 80% to 20% of DRV_{DD} , $f_S = 40$ MSPS		7.3		ns
Output enable (OE) to data output delay	Time required for outputs to have stable timings with respect to the input clock ⁽²⁾ after OE is activated			1000	Clock Cycles

⁽¹⁾ Data valid refers to 2 V for logic high and 0.8 V for logic low.

⁽²⁾ Data outputs are available within a clock from assertion of OE; however it takes 1000 clock cycles to ensure stable timing with respect to input clock.

⁽³⁾ Timing parameters are ensured by design and characterization and not tested in production.

PIN CONFIGURATION

**PFP PACKAGE
(TOP VIEW)**

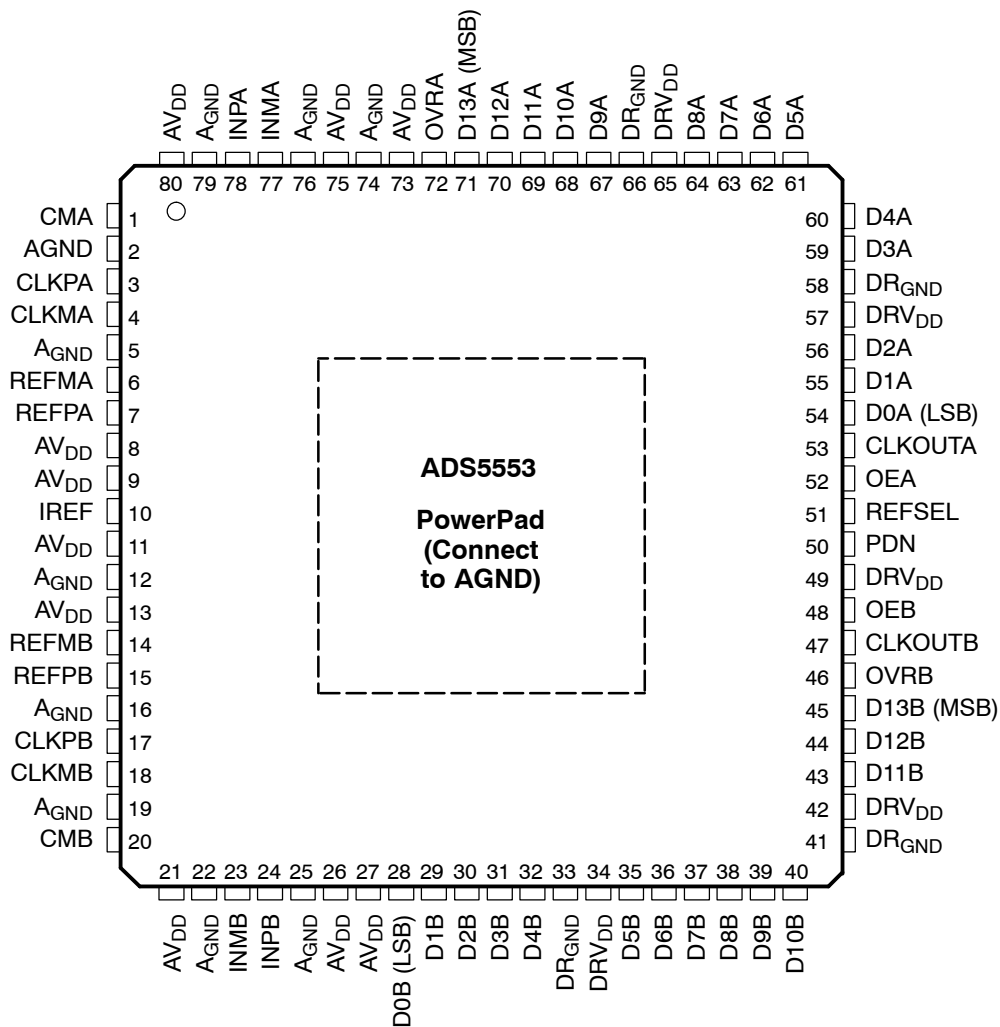

PIN ASSIGNMENTS

TERMINAL		NO. OF PINS	I/O	DESCRIPTION
NAME	NO.			
AV _{DD}	8, 9, 11, 13, 21, 26, 27, 73, 75, 80	10	I	Analog power supply
AGND	2, 5, 12, 16, 19, 22, 25, 74, 76, 79	10	I	Analog ground
CLKMA	4	1	I	Channel A differential input clock (negative)
CLKMB	18	1	I	Channel B differential input clock (negative)
CLKOUTA	53	1	O	Channel A clock out in sync with data
CLKOUTB		1	O	Channel B clock out in sync with data
CLKPA	3	1	I	Channel A differential input clock (positive)
CLKPB	17	1	I	Channel B differential input clock (positive)
CMA	1	1	O	Channel A common-mode output voltage
CMB	20	1	O	Channel B common-mode output voltage
D0A (LSB)–D13A (MSB)	54–56, 59–64, 67–71	14	O	Channel A parallel data
D0B (LSB)–D13B (MSB)	28–32, 35–40, 43–45	14	O	Channel B parallel data
DRV _{DD}	34, 42, 49, 57, 65	4	I	Output driver power supply
DR _{GND}	33, 41, 58, 66	4	I	Output driver ground
INMA	77	1	I	Channel A differential analog input (negative)
INMB	23	1	I	Channel B differential analog input (negative)
INPA	78	1	I	Channel A differential analog input (positive)
INPB	24	1	I	Channel B differential analog input (positive)
IREF	10	1	I	Current set, 56-k Ω resistor to GND
OEA	52	1	I	Channel A output enable (active high)
OEB	48	1	I	Channel B output enable (active high)
OVRA	72	1	O	Channel A over-range indicator bit
OVRB	46	1	O	Channel B over-range indicator bit
REFMA	6	1	I	Channel A reference voltage (negative); 0.1 μ F to GND
REFMB	14	1	I	Channel B reference voltage (negative); 0.1 μ F to GND
REFPA	7	1	I	Channel A reference voltage (positive); 0.1 μ F to GND
REFPB	15	1	I	Channel B reference voltage (positive); 0.1 μ F to GND
PDN	50	1	I	Power down active high. See Table 2
REFSEL	51	1	I	Reference select. 1 \rightarrow EXT. REF; 0 \rightarrow INT. REF

DEFINITION OF SPECIFICATIONS

Analog Bandwidth

The analog input frequency at which the power of the fundamental is reduced by 3 dB with respect to the low frequency value.

Aperture Delay

The delay between the falling edge of the input sampling clock and the actual time at which the sampling occurs.

Aperture Uncertainty (Jitter)

The sample-to-sample variation in aperture delay.

Clock Pulse Width/Duty Cycle

The duty cycle of a clock signal is the ratio of the time the clock signal remains at a logic high (clock pulse width) to the period of the clock signal. Duty cycle is typically expressed as a percentage. A perfect differential sine wave clock results in a 50% duty cycle.

Maximum Conversion Rate

The maximum sampling rate at which certified operation is given. All parametric testing is performed at this sampling rate unless otherwise noted.

Minimum Conversion Rate

The minimum sampling rate at which the ADC functions.

Differential Nonlinearity (DNL)

An ideal ADC exhibits code transitions at analog input values spaced exactly 1LSB apart. The DNL is the deviation of any single step from this ideal value, measured in units of LSBs.

Integral Nonlinearity (INL)

The INL is the deviation of the ADC's transfer function from a best fit line determined by a least squares curve fit of that transfer function, measured in units of LSBs.

Gain Error

The gain error is the deviation of the ADC's actual input full-scale range from its ideal value. The gain error is given as a percentage of the ideal input full-scale range. Gain error does not account for variations in the internal reference voltages (see the *Electrical Specifications* section for limits on the variation of V_{REFP} and V_{REFM}).

Offset Error

The offset error is the difference, given in number of LSBs, between the ADC's actual average idle channel output code and the ideal average idle channel output code. This quantity is often mapped into mV.

Temperature Drift

The temperature drift coefficient (with respect to gain error and offset error) specifies the change per degree celcius of the parameter from T_{MIN} to T_{MAX} . It is calculated by dividing the maximum deviation of the parameter across the T_{MIN} to T_{MAX} range by the difference $T_{MAX}-T_{MIN}$.

Signal-to-Noise Ratio

SNR is the ratio of the power of the fundamental (P_S) to the noise floor power (P_N), excluding the power at DC and the first eight harmonics.

$$SNR = 10\text{Log}_{10} \frac{P_S}{P_N}$$

SNR is either given in units of dBc (dB to carrier) when the absolute power of the fundamental is used as the reference, or dBFS (dB to full scale) when the power of the fundamental is extrapolated to the converter's full-scale range.

Signal-to-Noise and Distortion (SINAD)

SINAD is the ratio of the power of the fundamental (P_S) to the power of all the other spectral components including noise (P_N) and distortion (P_D), but excluding DC.

$$SINAD = 10\text{Log}_{10} \frac{P_S}{P_N + P_D}$$

SINAD is either given in units of dBc (dB to carrier) when the absolute power of the fundamental is used as the reference, or dBFS (dB to full scale) when the power of the fundamental is extrapolated to the converter's full-scale range.

Effective Number of Bits (ENOB)

The ENOB is a measure of a converter's performance as compared to the theoretical limit based on quantization noise.

$$ENOB = \frac{SINAD - 1.76}{6.02}$$

DEFINITION OF SPECIFICATIONS**Total Harmonic Distortion (THD)**

THD is the ratio of the power of the fundamental (P_S) to the power of the first eight harmonics (P_D).

$$\text{THD} = 10\text{Log}_{10} \frac{P_S}{P_D}$$

THD is typically given in units of dBc (dB to carrier).

Spurious-Free Dynamic Range (SFDR)

The ratio of the power of the fundamental to the highest other spectral component (either spur or harmonic). SFDR is typically given in units of dBc (dB to carrier).

Two-Tone Intermodulation Distortion

IMD3 is the ratio of the power of the fundamental (at frequencies f_1 and f_2) to the power of the worst spectral component at either frequency $2f_1 - f_2$ or $2f_2 - f_1$. IMD3 is either given in units of dBc (dB to carrier) when the absolute power of the fundamental is used as the reference, or dBFS (dB to full scale) when the power of the fundamental is extrapolated to the converter's full-scale range.

TYPICAL CHARACTERISTICS

Typical values are at $T_A = 25^\circ\text{C}$, $AV_{DD} = DRV_{DD} = 3.3\text{ V}$, differential input amplitude = -1 dBFS , sampling rate = 65 MSPS , unless otherwise noted

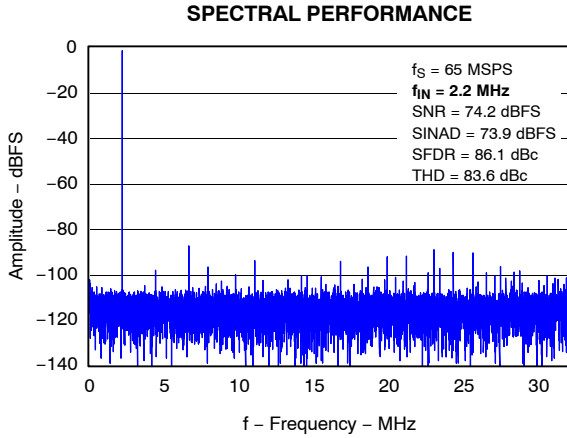

Figure 2

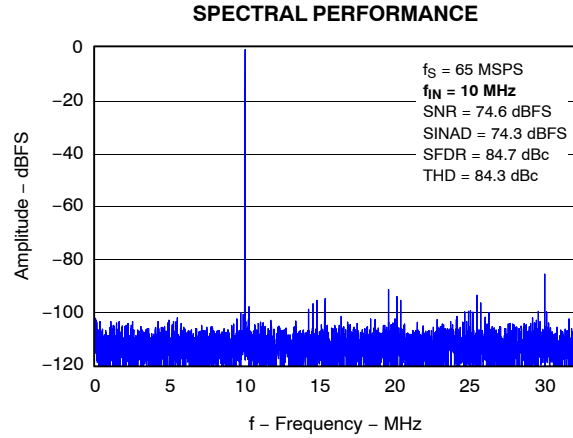

Figure 3

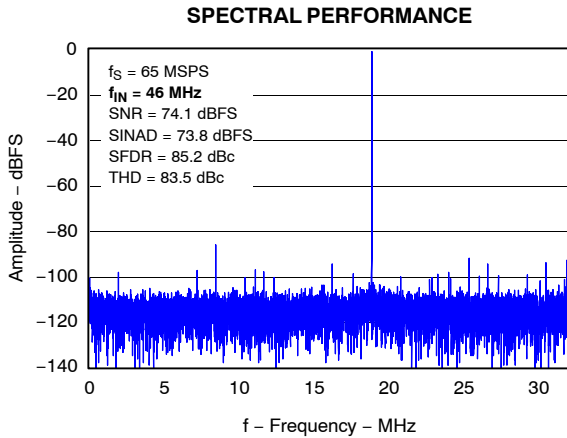

Figure 4

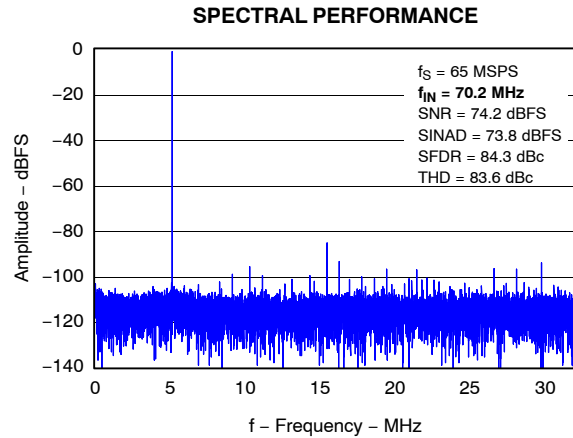

Figure 5

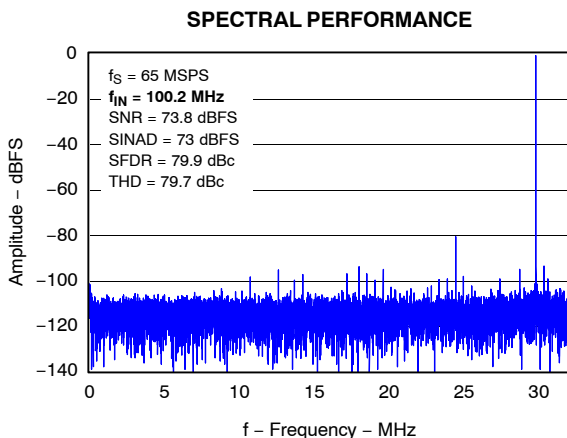

Figure 6

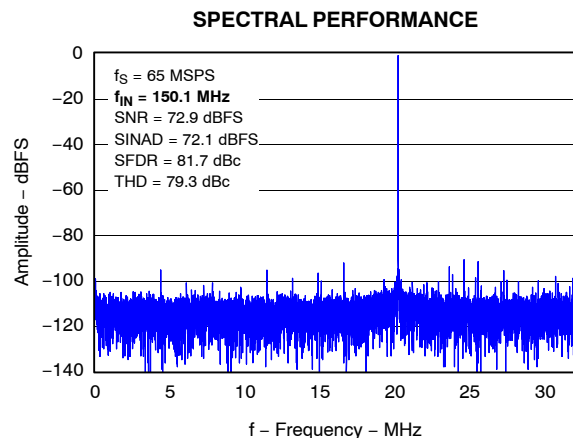

Figure 7

TYPICAL CHARACTERISTICS

Typical values are at $T_A = 25^\circ\text{C}$, $AV_{DD} = DRV_{DD} = 3.3\text{ V}$, differential input amplitude = -1 dBFS , sampling rate = 65 MSPS , unless otherwise noted

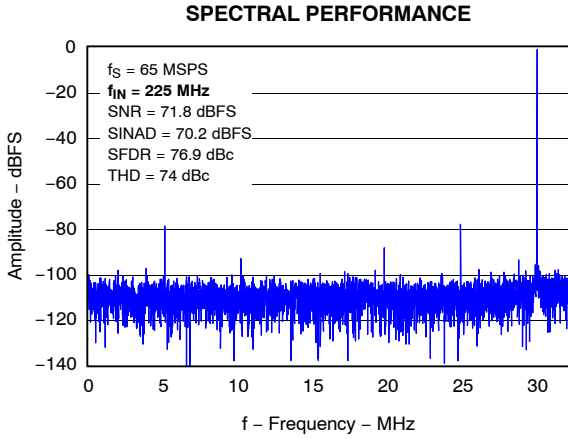

Figure 8

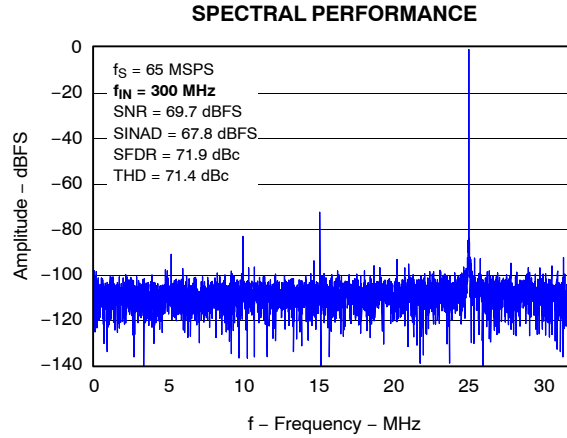

Figure 9

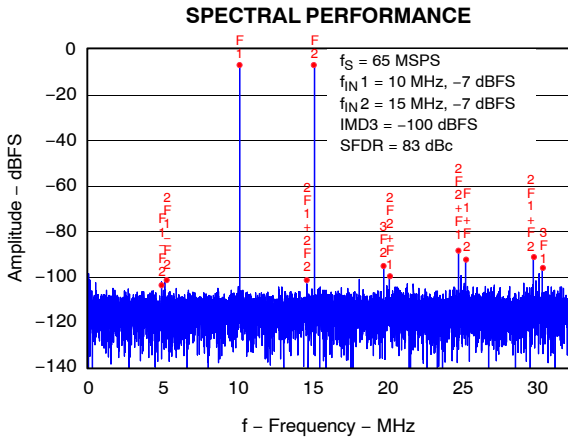

Figure 10

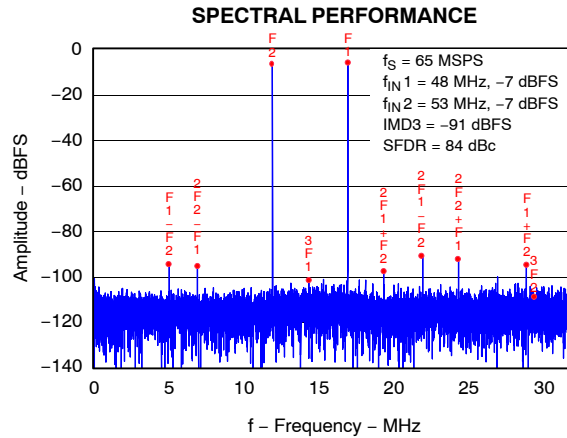

Figure 11

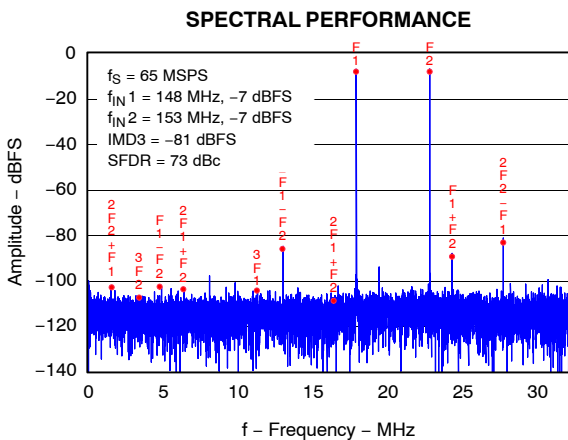

Figure 12

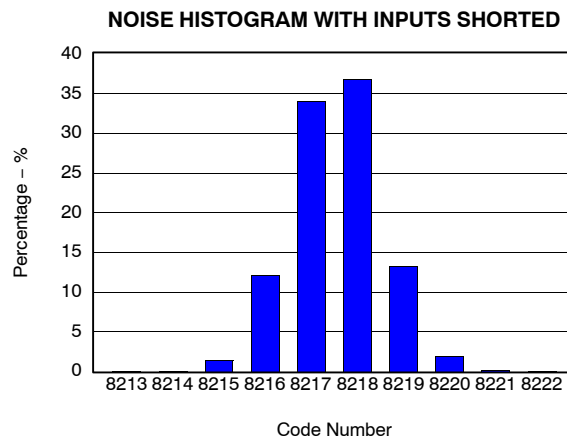

Figure 13

TYPICAL CHARACTERISTICS

Typical values are at $T_A = 25^\circ\text{C}$, $AV_{DD} = DRV_{DD} = 3.3\text{ V}$, differential input amplitude = -1 dBFS , sampling rate = 65 MSPS , unless otherwise noted

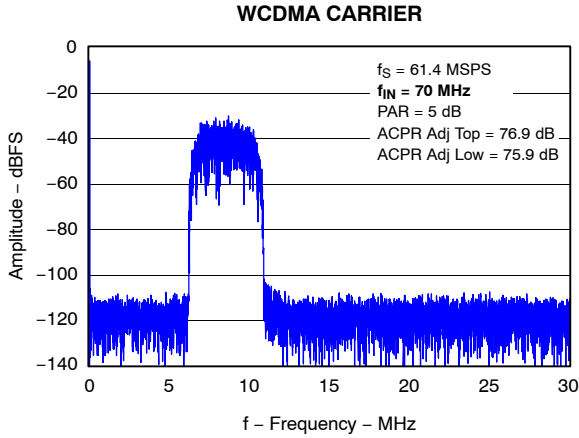

Figure 14

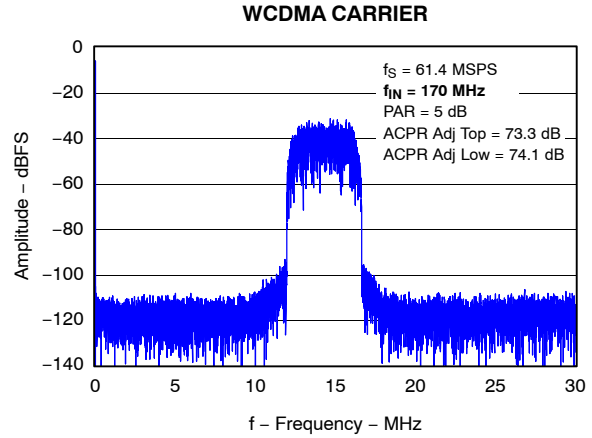

Figure 15

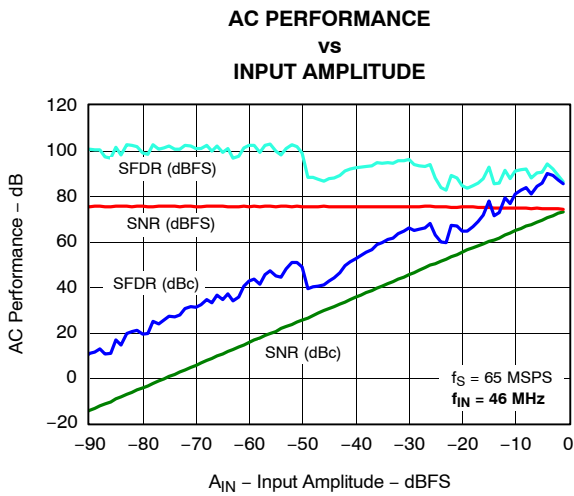

Figure 16

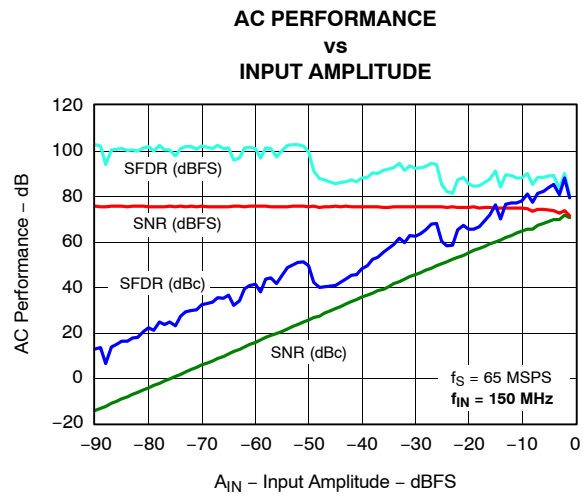

Figure 17

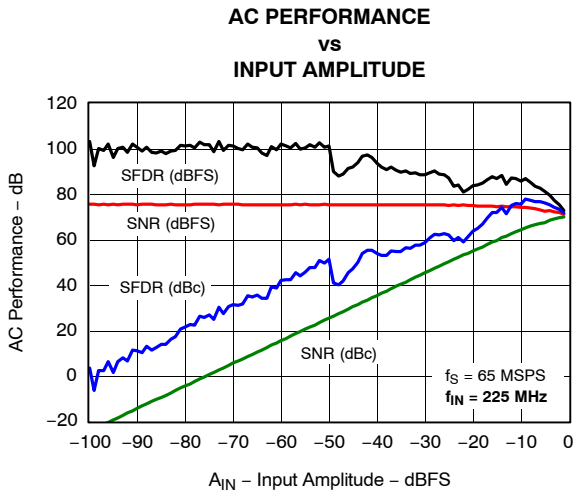

Figure 18

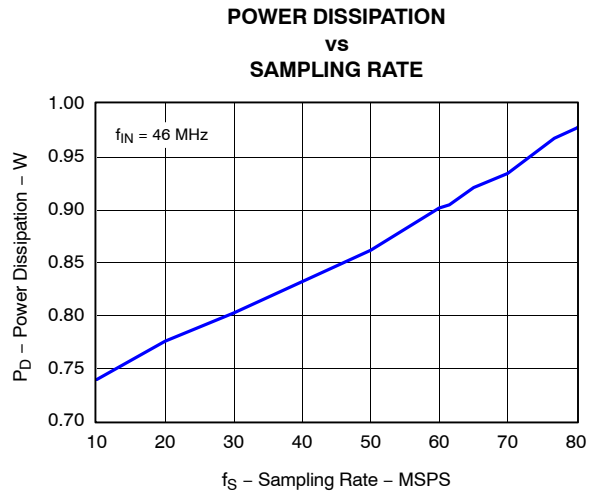

Figure 19

TYPICAL CHARACTERISTICS

Typical values are at $T_A = 25^\circ\text{C}$, $AV_{DD} = DRV_{DD} = 3.3\text{ V}$, differential input amplitude = -1 dBFS , sampling rate = 65 MSPS , unless otherwise noted

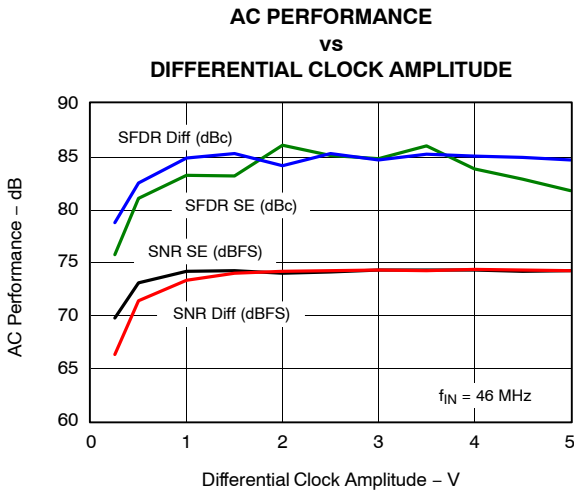

Figure 20

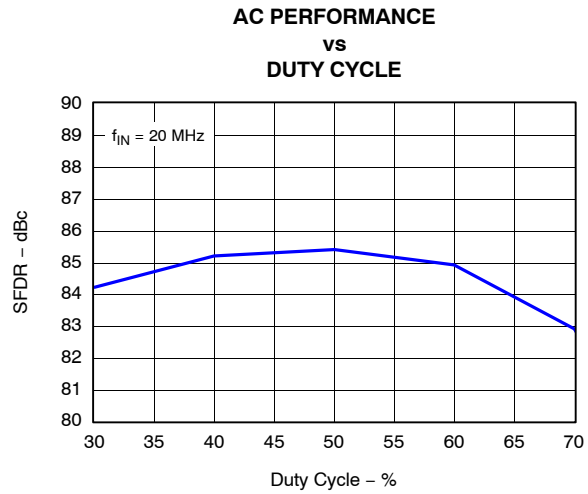

Figure 21

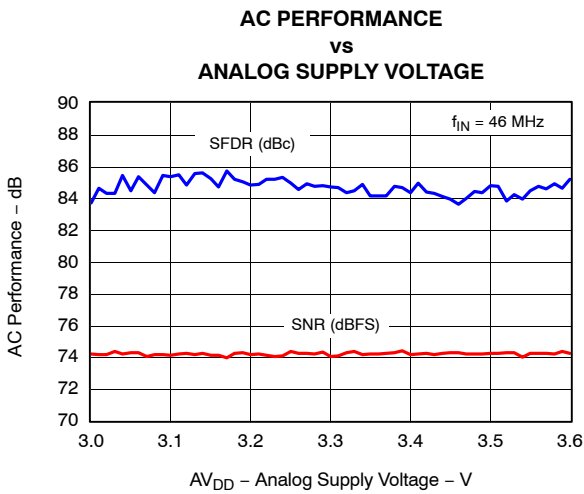

Figure 22

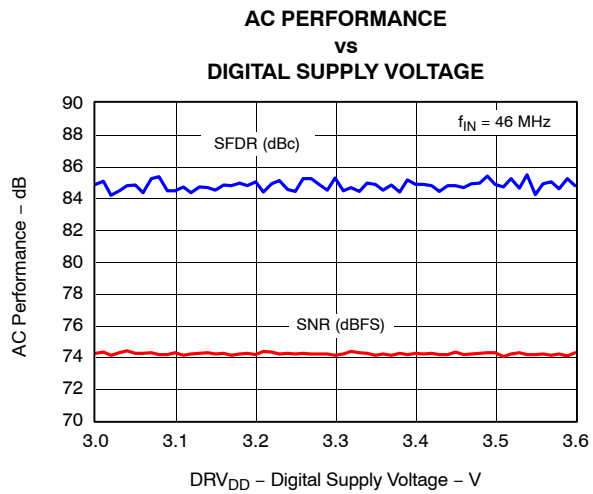

Figure 23

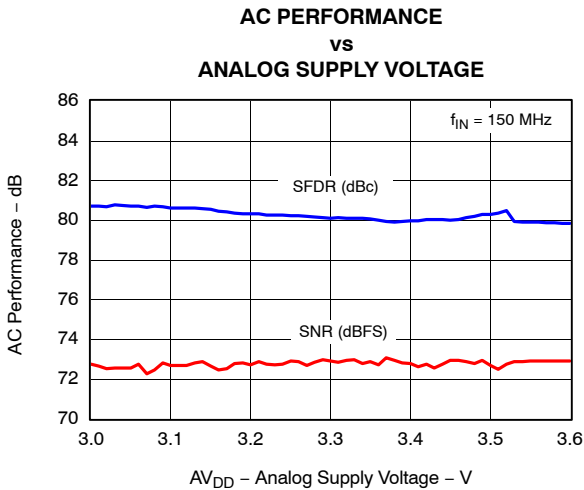

Figure 24

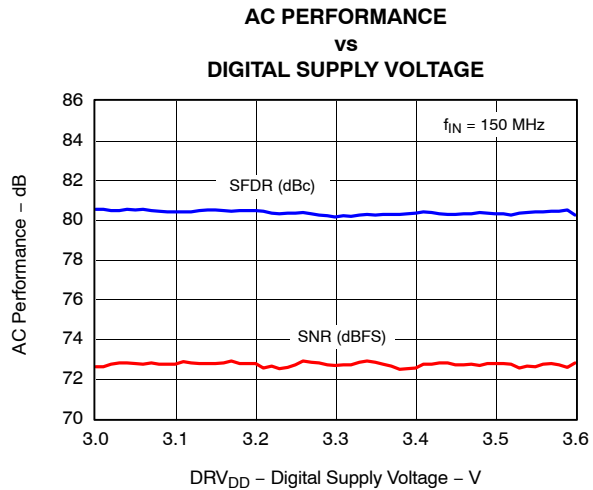

Figure 25

Typical values are at $T_A = 25^\circ\text{C}$, $AV_{DD} = DRV_{DD} = 3.3\text{ V}$, differential input amplitude = -1 dBFS , sampling rate = 65 MSPS , unless otherwise noted

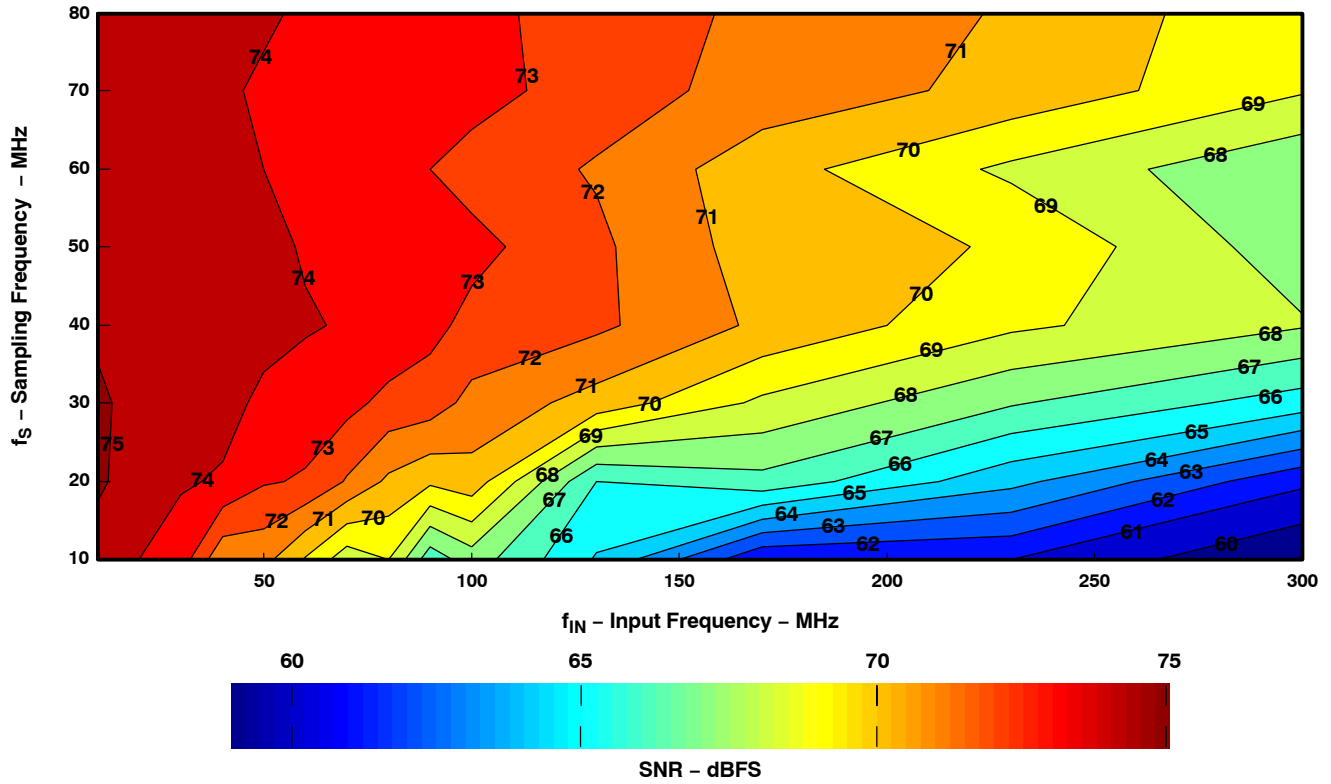

Figure 26.

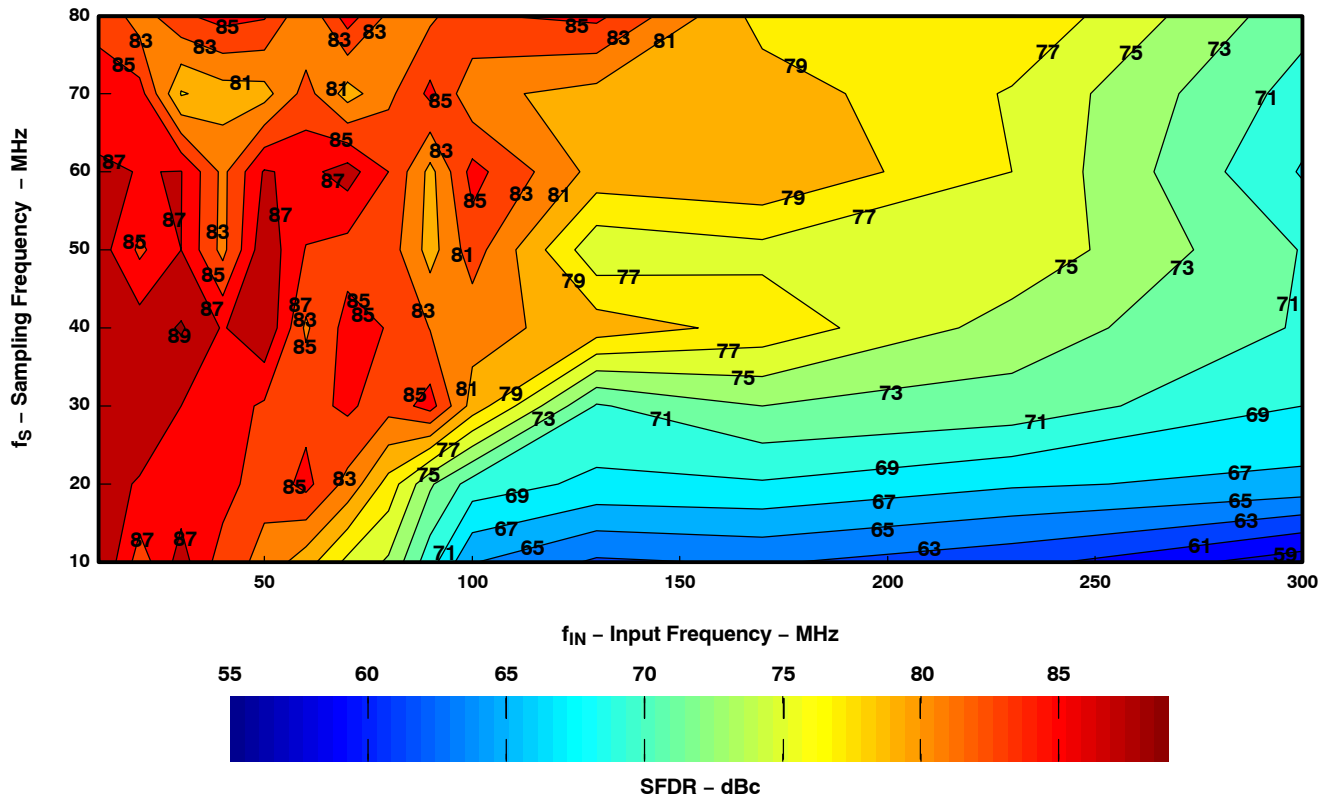

Figure 27.

APPLICATION INFORMATION

THEORY OF OPERATION

The ADS5553 is a low-power, dual 14 bit, 65 MSPS, CMOS, switched capacitor, pipeline ADC that operates from a single 3.3 V supply. The conversion process is initiated by a falling edge of the external input clock. Once the signal is captured by the input S&H, the input sample is sequentially converted by a series of small resolution stages, with the outputs combined in a digital correction logic block. Both the rising and the falling clock edges are used to propagate the sample through

the pipeline every half clock cycle. This process results in a data latency of 16.5 clock cycles, after which the output data is available as a 14 bit parallel word, coded in binary two's complement format.

INPUT CONFIGURATION

The analog input for the ADS5553 consists of a differential sample-and-hold architecture implemented using a switched capacitor technique, shown in Figure 28.

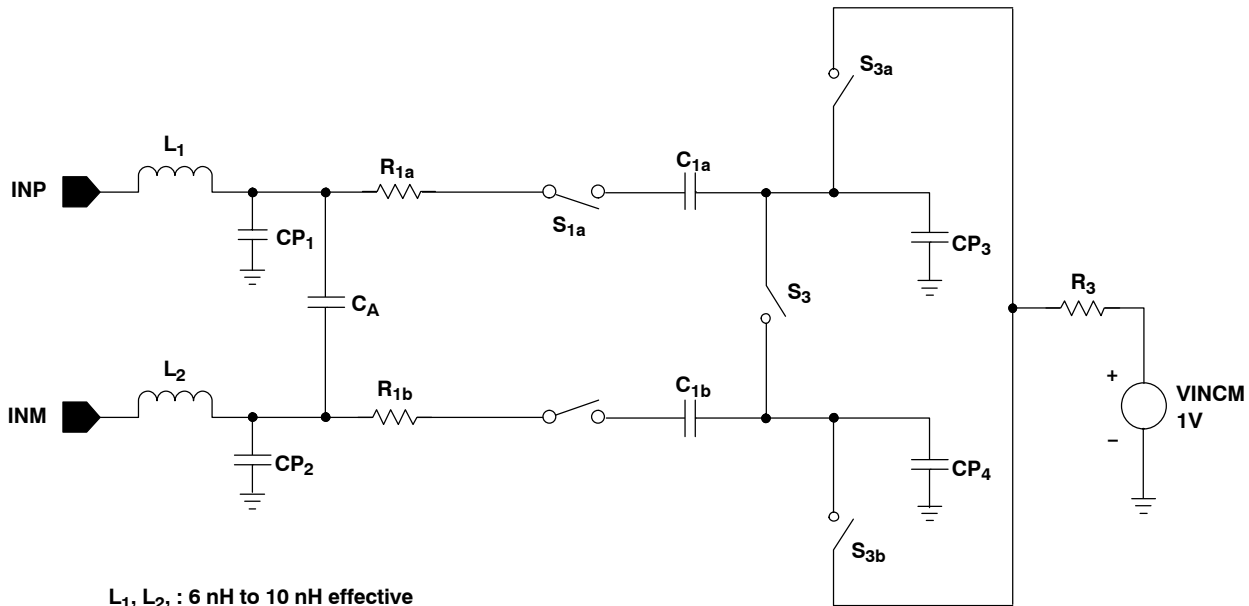

- L₁, L₂ : 6 nH to 10 nH effective
- R_{1a}, R_{1b} : 5 Ω to 8 Ω
- C_{1a}, C_{1b} : 2.2 pF to 2.6 pF
- CP₁, CP₂ : 1.8 pF to 2.2 pF
- CP₃, CP₄ : 1.2 pF to 1.8 pF
- C_A : 0.8 pF to 1.2 pF
- R₃ : 80 Ω to 120 Ω
- Switches : S_{1a}, S_{1b} : On Resistance : 35 Ω to 50 Ω
- S₂ : On Resistance : 7.5 Ω to 15 Ω
- S_{3a}, S_{3b} : On Resistance : 40 Ω to 60 Ω
- All switches Off Resistance : 10 GΩ

All switches are on in sampling phase which is approximately one half of a clock period.

Figure 28. Analog Input Stage

This differential input topology produces a high level of ac performance for high sampling rates. It also results in a high usable input bandwidth, especially important for high intermediate-frequency (IF) or undersampling applications. The ADS5553 requires each of the analog inputs (INP, INM) to be externally biased around the common-mode level of the internal circuitry (CM, pins 1 and 20). For a full-scale differential input, each of the differential lines of the input signal swings symmetrically between $CM + 0.575\text{ V}$ and $CM - 0.575\text{ V}$. This means that each input is driven with a signal of up to $CM \pm 0.575\text{ V}$, so that each input has a maximum differential signal of 1.15 V_{PP} for a total differential input signal swing of 2.3 V_{PP} . The maximum swing is determined by the two reference voltages, the top reference (REFPA, pin 7 and REFPB, pin 15) and the bottom reference (REFMA, pin 6 and REFMB, pin 18).

The ADS5553 obtains optimum performance when the analog inputs are driven differentially. The circuit shown in Figure 29 shows one possible configuration using an RF transformer.

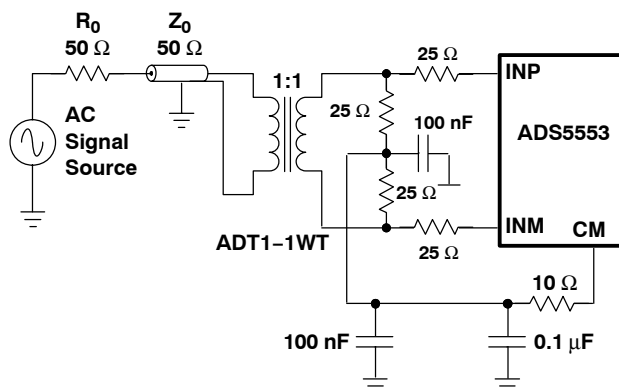

Figure 29. Transformer Input to Convert Single-Ended Signal to Differential Signal

The single-ended signal is fed to the primary winding of an RF transformer. Since the input signal must be biased around the common-mode voltage of the internal circuitry, the common-mode voltage (V_{CM}) from the ADS5553 is connected to the center-tap of the secondary winding. To ensure a steady low-noise V_{CM} reference, best performance is obtained when the CM output (pins 1 and 20) is filtered to ground with a $10\ \Omega$ series resistor and parallel $0.1\ \mu\text{F}$ and $0.001\ \mu\text{F}$ low-inductance capacitors as shown in Figure 29.

Output V_{CM} (pins 1 and 20) is designed to directly drive the ADC input. When providing a custom CM level, be aware that the input structure of the ADC sinks a common-mode current in the order of $200\ \mu\text{A}$ ($100\ \mu\text{A}$

per input). Equation (1) describes the dependency of the common-mode current and the sampling frequency:

$$20 + \frac{400\ \mu\text{A} \times f_s(\text{in MSPS})}{125\text{MSPS}} \quad (1)$$

This equation helps to design the output capability and impedance of the driving circuit accordingly.

When it is necessary to buffer or apply a gain to the incoming analog signal, it is possible to combine single-ended operational amplifiers with an RF transformer, or to use a differential input/output amplifier without a transformer, to drive the input of the ADS5553. Texas Instruments offers a wide selection of single-ended operational amplifiers (including the THS3201, THS3202, OPA847, and OPA695) that can be selected depending on the application. An RF gain block amplifier, such as Texas Instruments THS9001, can also be used with an RF transformer for high input frequency applications. The THS4503/6 are recommended differential input/output amplifiers. Table 1 lists the recommended amplifiers.

When using single-ended operational amplifiers (such as the THS3201, THS3202, OPA847, or OPA695) to provide gain, a three-amplifier circuit is recommended with one amplifier driving the primary of an RF transformer and one amplifier in each of the legs of the secondary driving the two differential inputs of the ADS5553. These three amplifier circuits minimize even-order harmonics. For high frequency inputs, an RF gain block amplifier can be used to drive a transformer primary; in this case, the transformer secondary connections can drive the input of the ADS5553 directly, as shown in Figure 29 or with the addition of the filter circuit shown in Figure 30.

Figure 30 illustrates how R_{IN} and C_{IN} can be placed to isolate the signal source from the switching inputs of the ADC and to implement a low-pass RC filter to limit the input noise in the ADC. It is recommended that these components be included in the ADS5553 circuit layout when any of the amplifier circuits discussed previously are used. The components allow fine-tuning of the circuit performance. Any mismatch between the differential lines of the ADS5553 input produces a degradation in performance at high input frequencies, mainly characterized by an increase in the even-order harmonics. In this case, special care should be taken to keep as much electrical symmetry as possible between both inputs.

Another possible configuration for lower-frequency signals is the use of differential input/output amplifiers that can simplify the driver circuit for applications

requiring dc coupling of the input. Flexible in their configurations (see Figure 31), such amplifiers can be used for single-ended-to-differential conversion, signal amplification.

Table 1. Recommended Amplifiers to Drive the Input of the ADS5553

INPUT SIGNAL FREQUENCY	RECOMMENDED AMPLIFIER	TYPE OF AMPLIFIER	USE WITH TRANSFORMER?
DC to 20 MHz	THS4503/6	Differential In/Out Amp	No
DC to 50 MHz	OPA847	Operational Amp	Yes
10 MHz to 120 MHz	OPA695	Operational Amp	Yes
	THS3201	Operational Amp	Yes
	THS3202	Operational Amp	Yes
Over 100 MHz	THS9001	RF Gain Block	Yes

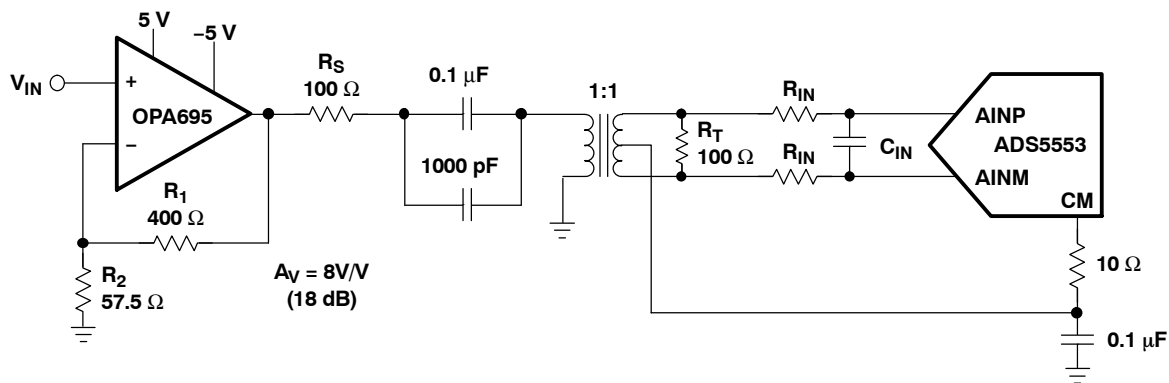

Figure 30. Converting a Single-Ended Input Signal to a Differential Signal Using an RF Transformer

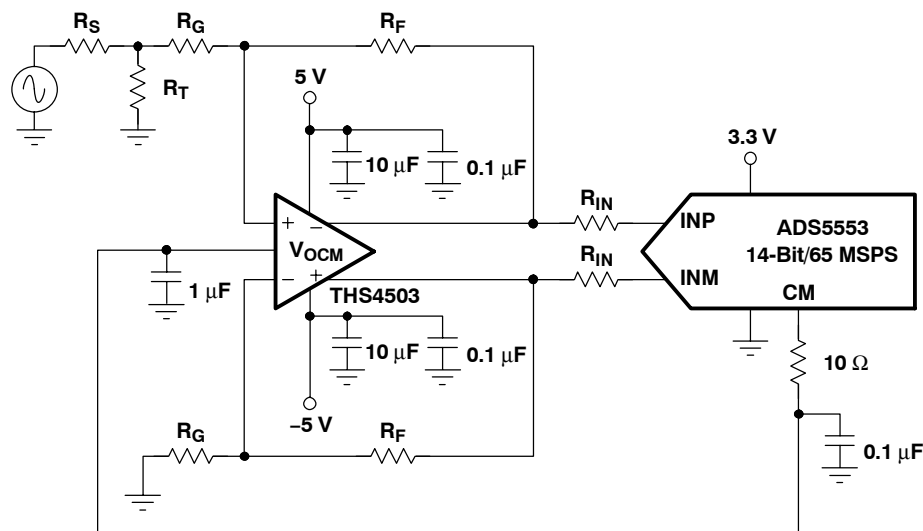

Figure 31. Using the THS4503 With the ADS5553

INPUT VOLTAGE OVER-STRESS

The ADS5553 can handle absolute maximum voltages of 3.6 V DC on the input pins INP and INM. For DC inputs between 3.6 V and 3.8 V, a 25 Ω resistor is required in series with the input pins. For inputs above 3.8 V, the device can handle only transients, which need to have less than 5% duty cycle of overstress. The input pins connect internally to an ESD diode to AV_{DD} , as well as a switched capacitor circuit. The sampling capacitor of the switched capacitor circuit connects to the input pins through a switch in the sample phase. In this phase, an input larger than 2.65 V would cause the switched capacitor circuit to present an equivalent load of a forward biased diode to 2.65 V, in series with a 60 Ω impedance. Also, beyond the voltage on AV_{DD} , the ESD diode to AV_{DD} starts to become forward biased.

In the phase where the sampling switch is off, the diode loading from the input switched capacitor circuit is disconnected from the pin, while the ESD loading to AV_{DD} is still present.

CAUTION:

A violation of any of the previously stated conditions could damage the device (or reduce its lifetime) either due to electromigration or gate oxide integrity. Care should be taken not to expose the device to input over-voltage for extended periods of time as it may degrade device reliability.

POWER SUPPLY SEQUENCE

The preferred mode of power supply sequencing is to power up AV_{DD} first, followed by DRV_{DD} . Raising both supplies simultaneously is also a valid power supply sequence. In the event that DRV_{DD} powers up before AV_{DD} in the system, AV_{DD} must power up within 10 ms of DRV_{DD} .

POWER DOWN

The device enters power down in one of two ways: either by reducing the clock speed to between dc and 1 MHz or by selecting any of the modes in Table 2. If reducing the clock speed, power-down may be initiated for any clock frequency below 10 MHz. The actual frequency at which the device powers down varies from device to device.

Table 2. Powerdown Mode Selection

PDN (Pin 50)	OEA (Pin 52)	OEB (Pin 48)	Out A	Out B	ADC A	ADC B
0	0	0	Off	Off	On	On
0	0	1	Off	On	On	On
0	1	0	On	Off	On	On
0	1	1	On	On	On	On
1	0	0	Off	Off	Off	Off
1	0	1	Off	On	Off	On
1	1	0	On	Off	On	Off
1	1	1	On	On	On	On

REFERENCE CIRCUIT

The ADS5553 has built-in internal reference generation, requiring no external circuitry on the printed circuit board (PCB). For optimum performance, it is best to connect both REFP and REFM to ground with a 1 μ F decoupling capacitor in series with a 20 Ω resistor, as shown in Figure 32. In addition, an external 56.2-k Ω resistor should be connected from IREF (pin 10) to AGND to set the proper current for the operation of the ADC, as shown in Figure 32. No capacitor should be connected between pin 31 and ground; only the 56.2 k Ω resistor should be used.

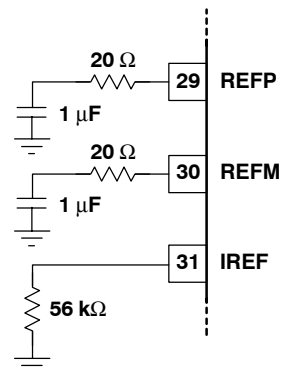

Figure 32. REFP, REFM, and IREF Connections for Optimum Performance

CLOCK INPUT

The ADS5553 clock input can be driven with either a differential clock signal or a single-ended clock input, with little or no difference in performance between both configurations. The common-mode voltage of the clock inputs is set internally to CM using internal 5-kΩ resistors that connect CLKP and CLKM to CM, as shown in Figure 33.

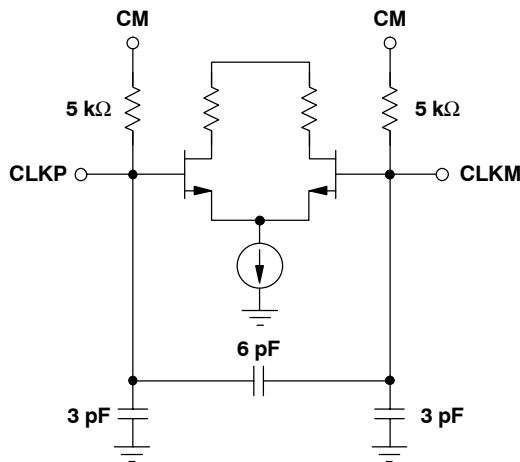

Figure 33. Clock Inputs

When driven with a single-ended CMOS clock input, it is best to connect CLKM to ground with a 0.01 μF capacitor, while CLKP is ac-coupled with a 0.01 μF capacitor to the clock source, as shown in Figure 34.

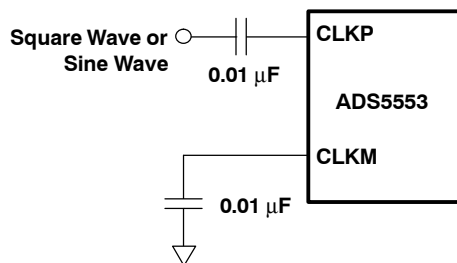

Figure 34. AC-Coupled, Single-Ended Clock Input

The ADS5553 clock input can also be driven differentially, reducing susceptibility to common-mode noise. In this case, it is best to connect both clock inputs to the differential input clock signal with 0.01 μF capacitors, as shown in Figure 35.

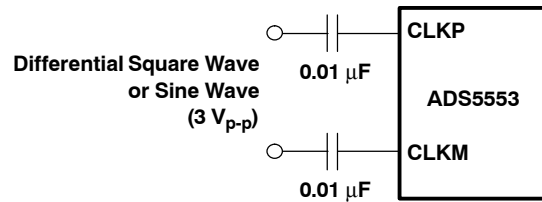

Figure 35. AC-Coupled, Differential Clock Input

For high input frequency sampling, it is recommended to use a clock source with low jitter. Additionally, the internal ADC core uses both edges of the clock for the conversion process. This means that, ideally, a 50% duty cycle should be provided. Figure 24 shows the performance variation of the ADC versus clock duty cycle.

Bandpass filtering of the source can help produce a 50% duty cycle clock and reduce the effect of jitter. When using a sinusoidal clock, the clock jitter further improves as the amplitude is increased. In that sense, using a differential clock allows for the use of larger amplitudes without exceeding the supply rails and absolute maximum ratings of the ADC clock input. Figure 23 shows the performance variation of the device versus input clock amplitude. For detailed clocking schemes based on transformer or PECL-level clocks, see the ADS5553EVM user’s guide (SLWU010), available for download from www.ti.com.

OUTPUT INFORMATION

Each of the two ADCs provide 14 data outputs in two's complement format (D13 to D0, with D13 being the MSB and D0 the LSB), a data-ready signal (CLKOUT), and an out-of-range indicator (OVR) that equals 1 when the output reaches the full-scale limits.

In addition, output enable control (pins 48 and 52) are provided to tri-state the outputs. See Table 2 for details.

The output circuitry of the ADS5553 has been designed to minimize the noise produced by the transients of the data switching and in particular its coupling to the ADC analog circuitry. Output D0 senses the load capacitance and adjusts the drive capability of all the output pins of the ADC to maintain the same output slew rate described in the timing diagram of Figure 1, as long as all outputs (including CLKOUT) have a similar load as the one at D0. This circuit also reduces the sensitivity of the output timing versus supply voltage or temperature. External series resistors with the output are not necessary.

PowerPAD PACKAGE

The PowerPAD package is a thermally enhanced standard size IC package designed to eliminate the use of bulky heatsinks and slugs traditionally used in thermal packages. This package can be easily mounted using standard printed circuit board (PCB) assembly techniques, and can be removed and replaced using standard repair procedures.

The PowerPAD package is designed so that the leadframe die pad (or thermal pad) is exposed on the bottom of the IC. This provides an extremely low thermal resistance path between the die and the exterior of the package. The thermal pad on the bottom of the IC can then be soldered directly to the printed circuit board (PCB), using the PCB as a heatsink.

Assembly Process

1. Prepare the PCB top-side etch pattern including etch for the leads as well as the thermal pad as illustrated in the *Mechanical Data* section.
2. Place a 5-by-5 array of thermal vias in the thermal pad area. These holes should be 13 mils in diameter. The small size prevents wicking of the solder through the holes.
3. It is recommended to place a small number of 25 mil diameter holes under the package, but outside the thermal pad area to provide an additional heat path.
4. Connect all holes (both those inside and outside the thermal pad area) to an internal copper plane (such as a ground plane).
5. Do not use the typical web or spoke via connection pattern when connecting the thermal vias to the ground plane. The spoke pattern increases the thermal resistance to the ground plane.
6. The top-side solder mask should leave exposed the terminals of the package and the thermal pad area.
7. Cover the entire bottom side of the PowerPAD vias to prevent solder wicking.
8. Apply solder paste to the exposed thermal pad area and all of the package terminals.

For more detailed information regarding the PowerPAD package and its thermal properties, see either the SLMA004B Application Brief *PowerPAD Made Easy* or the SLMA002 Technical Brief *PowerPAD Thermally Enhanced Package*.

PACKAGING INFORMATION

Orderable Device	Status (1)	Package Type	Package Drawing	Pins	Package Qty	Eco Plan (2)	Lead finish/ Ball material (6)	MSL Peak Temp (3)	Op Temp (°C)	Device Marking (4/5)	Samples
ADS5553IPFP	ACTIVE	HTQFP	PFP	80	96	RoHS & Green	NIPDAU	Level-3-260C-168 HR	-40 to 85	ADS5553I	Samples

(1) The marketing status values are defined as follows:

ACTIVE: Product device recommended for new designs.

LIFEBUY: TI has announced that the device will be discontinued, and a lifetime-buy period is in effect.

NRND: Not recommended for new designs. Device is in production to support existing customers, but TI does not recommend using this part in a new design.

PREVIEW: Device has been announced but is not in production. Samples may or may not be available.

OBSOLETE: TI has discontinued the production of the device.

(2) **RoHS:** TI defines "RoHS" to mean semiconductor products that are compliant with the current EU RoHS requirements for all 10 RoHS substances, including the requirement that RoHS substance do not exceed 0.1% by weight in homogeneous materials. Where designed to be soldered at high temperatures, "RoHS" products are suitable for use in specified lead-free processes. TI may reference these types of products as "Pb-Free".

RoHS Exempt: TI defines "RoHS Exempt" to mean products that contain lead but are compliant with EU RoHS pursuant to a specific EU RoHS exemption.

Green: TI defines "Green" to mean the content of Chlorine (Cl) and Bromine (Br) based flame retardants meet JS709B low halogen requirements of <=1000ppm threshold. Antimony trioxide based flame retardants must also meet the <=1000ppm threshold requirement.

(3) MSL, Peak Temp. - The Moisture Sensitivity Level rating according to the JEDEC industry standard classifications, and peak solder temperature.

(4) There may be additional marking, which relates to the logo, the lot trace code information, or the environmental category on the device.

(5) Multiple Device Markings will be inside parentheses. Only one Device Marking contained in parentheses and separated by a "-" will appear on a device. If a line is indented then it is a continuation of the previous line and the two combined represent the entire Device Marking for that device.

(6) Lead finish/Ball material - Orderable Devices may have multiple material finish options. Finish options are separated by a vertical ruled line. Lead finish/Ball material values may wrap to two lines if the finish value exceeds the maximum column width.

Important Information and Disclaimer: The information provided on this page represents TI's knowledge and belief as of the date that it is provided. TI bases its knowledge and belief on information provided by third parties, and makes no representation or warranty as to the accuracy of such information. Efforts are underway to better integrate information from third parties. TI has taken and continues to take reasonable steps to provide representative and accurate information but may not have conducted destructive testing or chemical analysis on incoming materials and chemicals. TI and TI suppliers consider certain information to be proprietary, and thus CAS numbers and other limited information may not be available for release.

In no event shall TI's liability arising out of such information exceed the total purchase price of the TI part(s) at issue in this document sold by TI to Customer on an annual basis.

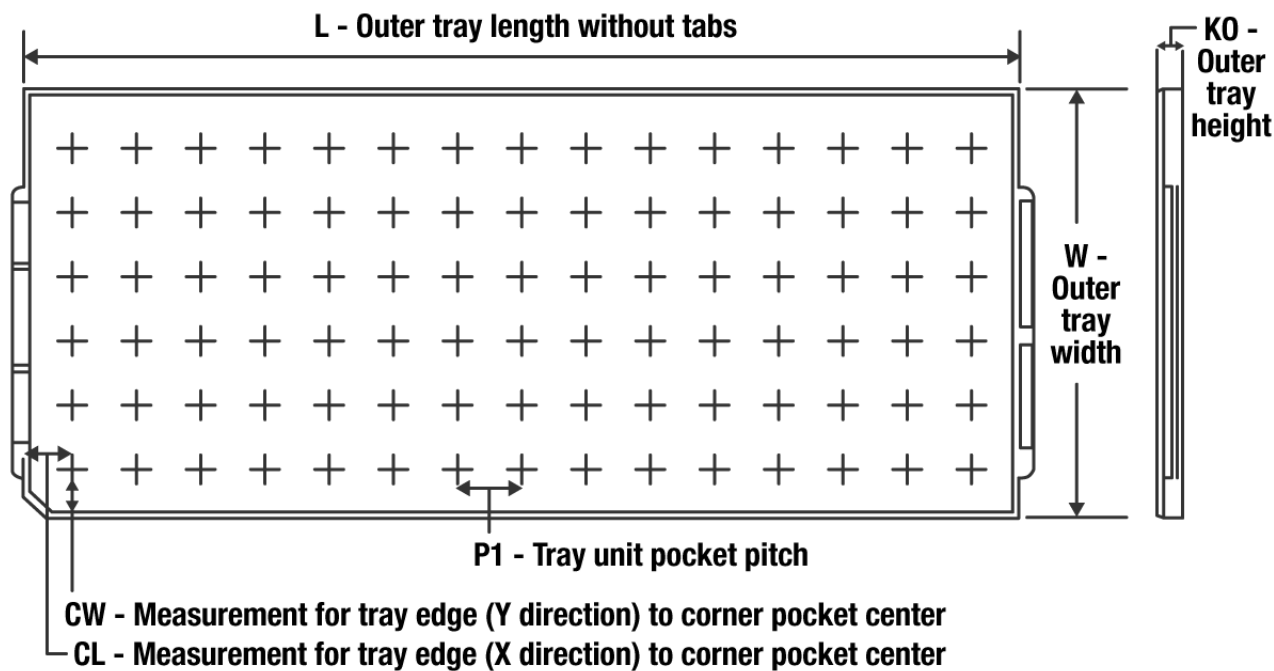
TRAY

Chamfer on Tray corner indicates Pin 1 orientation of packed units.

*All dimensions are nominal

Device	Package Name	Package Type	Pins	SPQ	Unit array matrix	Max temperature (°C)	L (mm)	W (mm)	K0 (µm)	P1 (mm)	CL (mm)	CW (mm)
ADS5553IPFP	PFP	HTQFP	80	96	6 x 16	150	315	135.9	7620	18.7	17.25	18.3

MECHANICAL DATA

PFP (S-PQFP-G80)

PowerPAD™ PLASTIC QUAD FLATPACK

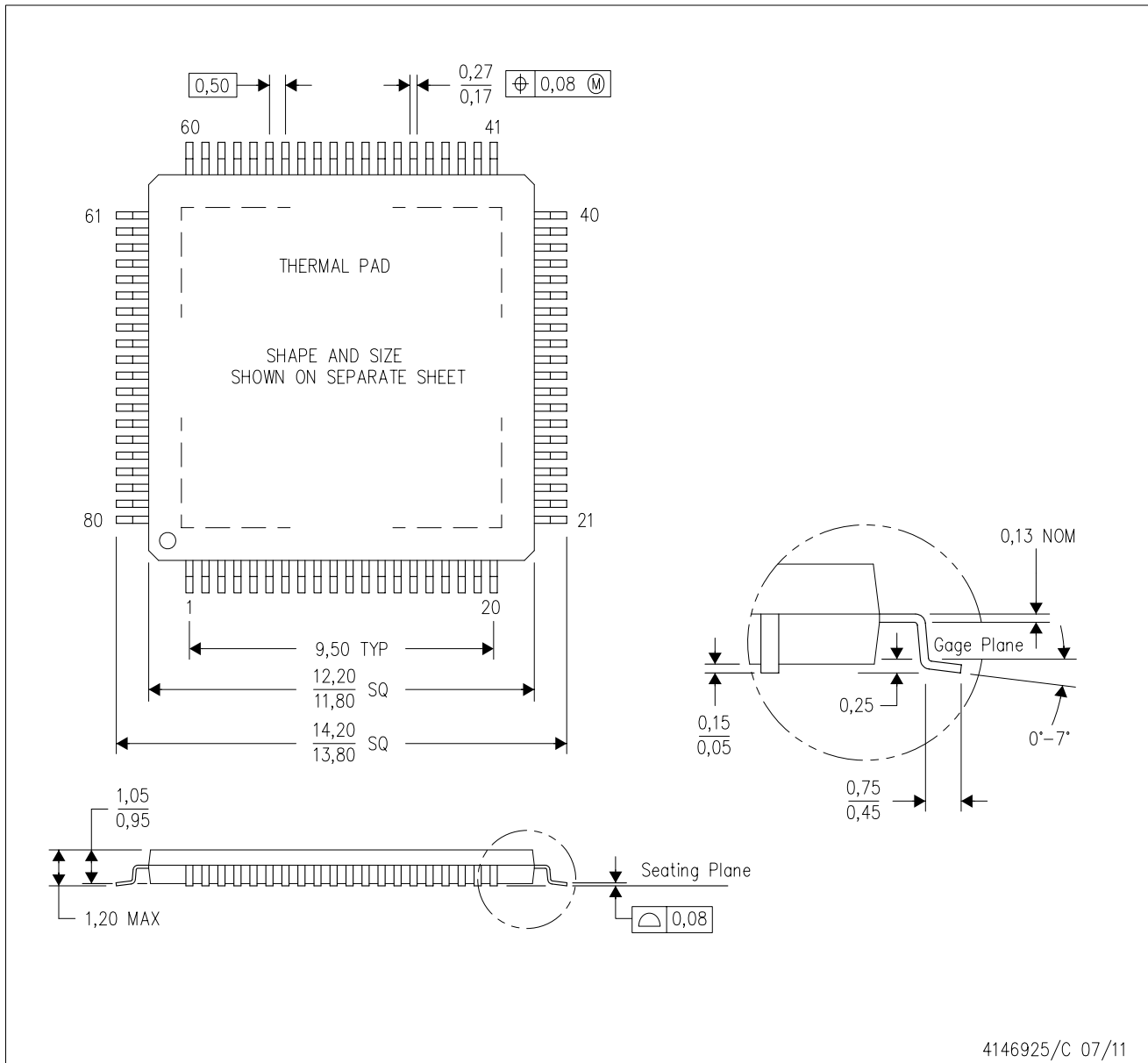

- NOTES:
- A. All linear dimensions are in millimeters.
 - B. This drawing is subject to change without notice.
 - C. Body dimensions do not include mold flash or protrusion
 - D. This package is designed to be soldered to a thermal pad on the board. Refer to Technical Brief, PowerPad Thermally Enhanced Package, Texas Instruments Literature No. SLMA002 for information regarding recommended board layout. This document is available at www.ti.com <<http://www.ti.com>>.
 - E. See the additional figure in the Product Data Sheet for details regarding the exposed thermal pad features and dimensions.
 - F. Falls within JEDEC MS-026

PowerPAD is a trademark of Texas Instruments.

THERMAL PAD MECHANICAL DATA

PFP (S-PQFP-G80)

PowerPAD™ PLASTIC QUAD FLATPACK

THERMAL INFORMATION

This PowerPAD™ package incorporates an exposed thermal pad that is designed to be attached to a printed circuit board (PCB). The thermal pad must be soldered directly to the PCB. After soldering, the PCB can be used as a heatsink. In addition, through the use of thermal vias, the thermal pad can be attached directly to the appropriate copper plane shown in the electrical schematic for the device, or alternatively, can be attached to a special heatsink structure designed into the PCB. This design optimizes the heat transfer from the integrated circuit (IC).

For additional information on the PowerPAD package and how to take advantage of its heat dissipating abilities, refer to Technical Brief, PowerPAD Thermally Enhanced Package, Texas Instruments Literature No. SLMA002 and Application Brief, PowerPAD Made Easy, Texas Instruments Literature No. SLMA004. Both documents are available at www.ti.com.

The exposed thermal pad dimensions for this package are shown in the following illustration.

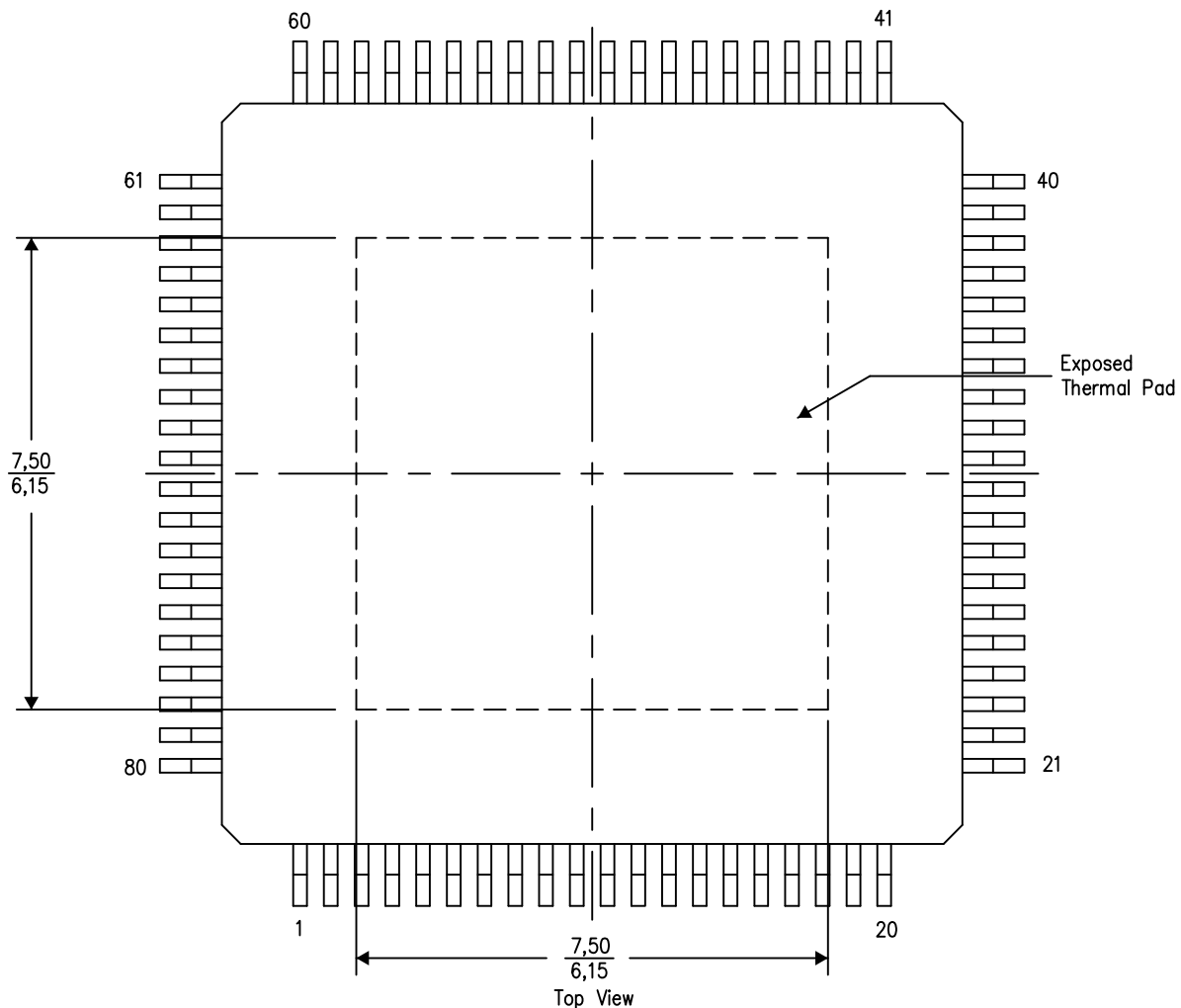

4206327-2/P 05/14

NOTE: A. All linear dimensions are in millimeters

PowerPAD is a trademark of Texas Instruments

LAND PATTERN DATA

PFP (S-PQFP-G80)

PowerPAD™ PLASTIC QUAD FLATPACK

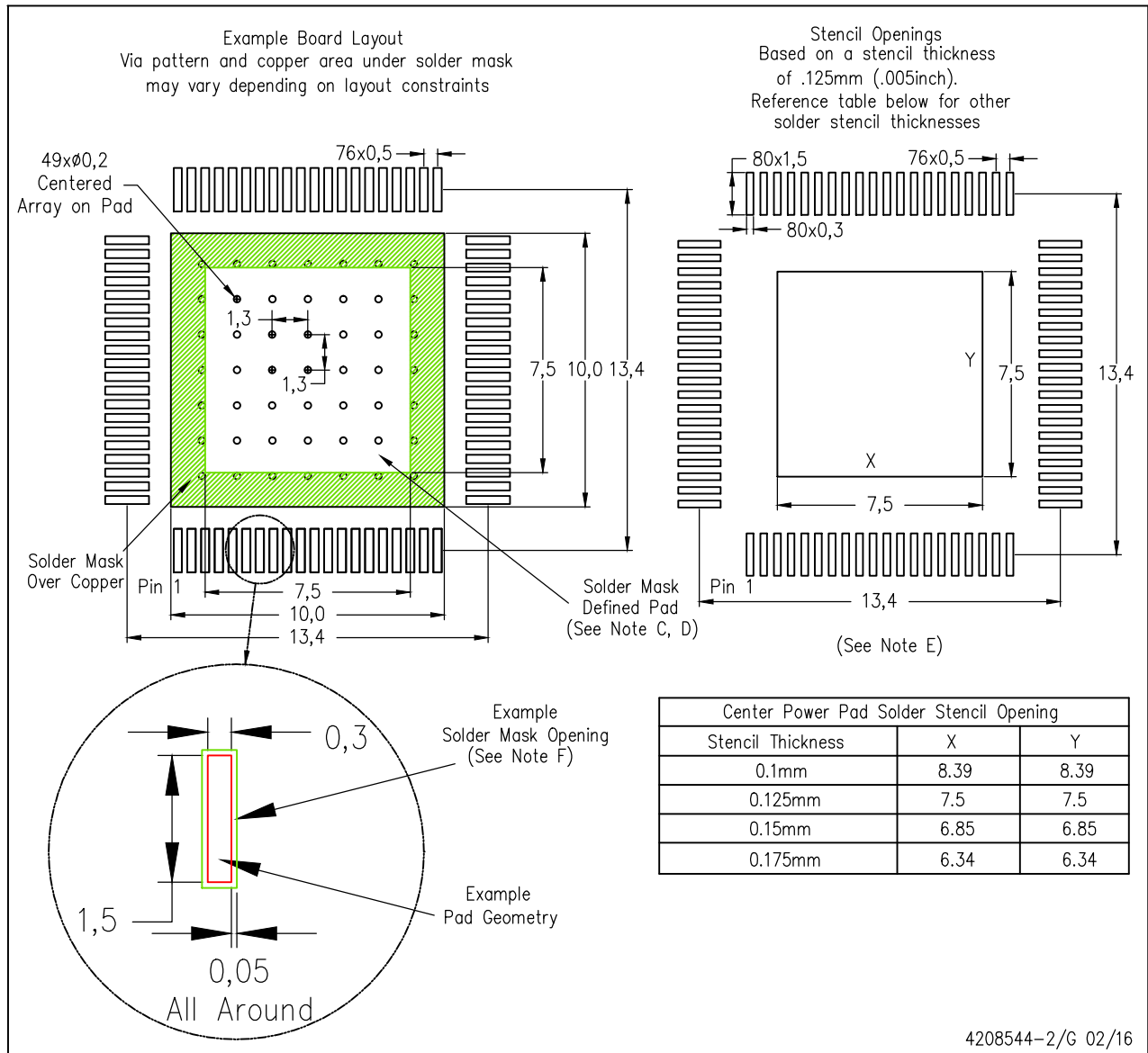

4208544-2/G 02/16

- NOTES:
- All linear dimensions are in millimeters.
 - This drawing is subject to change without notice.
 - Customers should place a note on the circuit board fabrication drawing not to alter the center solder mask defined pad.
 - This package is designed to be soldered to a thermal pad on the board. Refer to Technical Brief, PowerPad Thermally Enhanced Package, Texas Instruments Literature No. SLMA002, SLMA004, and also the Product Data Sheets for specific thermal information, via requirements, and recommended board layout. These documents are available at www.ti.com <<http://www.ti.com>>. Publication IPC-7351 is recommended for alternate designs.
 - Laser cutting apertures with trapezoidal walls and also rounding corners will offer better paste release. Customers should contact their board assembly site for stencil design recommendations. Example stencil design based on a 50% volumetric metal load solder paste. Refer to IPC-7525 for other stencil recommendations.
 - Customers should contact their board fabrication site for solder mask tolerances between and around signal pads.

PowerPAD is a trademark of Texas Instruments.

IMPORTANT NOTICE AND DISCLAIMER

TI PROVIDES TECHNICAL AND RELIABILITY DATA (INCLUDING DATA SHEETS), DESIGN RESOURCES (INCLUDING REFERENCE DESIGNS), APPLICATION OR OTHER DESIGN ADVICE, WEB TOOLS, SAFETY INFORMATION, AND OTHER RESOURCES "AS IS" AND WITH ALL FAULTS, AND DISCLAIMS ALL WARRANTIES, EXPRESS AND IMPLIED, INCLUDING WITHOUT LIMITATION ANY IMPLIED WARRANTIES OF MERCHANTABILITY, FITNESS FOR A PARTICULAR PURPOSE OR NON-INFRINGEMENT OF THIRD PARTY INTELLECTUAL PROPERTY RIGHTS.

These resources are intended for skilled developers designing with TI products. You are solely responsible for (1) selecting the appropriate TI products for your application, (2) designing, validating and testing your application, and (3) ensuring your application meets applicable standards, and any other safety, security, regulatory or other requirements.

These resources are subject to change without notice. TI grants you permission to use these resources only for development of an application that uses the TI products described in the resource. Other reproduction and display of these resources is prohibited. No license is granted to any other TI intellectual property right or to any third party intellectual property right. TI disclaims responsibility for, and you will fully indemnify TI and its representatives against, any claims, damages, costs, losses, and liabilities arising out of your use of these resources.

TI's products are provided subject to [TI's Terms of Sale](#) or other applicable terms available either on ti.com or provided in conjunction with such TI products. TI's provision of these resources does not expand or otherwise alter TI's applicable warranties or warranty disclaimers for TI products.

TI objects to and rejects any additional or different terms you may have proposed.

Mailing Address: Texas Instruments, Post Office Box 655303, Dallas, Texas 75265
Copyright © 2022, Texas Instruments Incorporated