

具有 LVDS、JESD 输出的 ADS52J90 10 位、12 位、14 位多通道低功耗高速 ADC

1 特性

- 16 通道 ADC，可配置为转换 8、16 或 32 路输入
- 10 位、12 位和 14 位三种分辨率模式
- 最大 ADC 转换速率：
 - 10 位模式下为 100MSPS
 - 12 位模式下为 80MSPS
 - 14 位模式下为 65MSPS
- 16 个 ADC 经配置可进行下列转换：
 - 8 个输入，采样率为 ADC 转换速率的 2 倍
 - 16 个输入，采样率与 ADC 转换速率相同
 - 32 个输入，采样率为 ADC 转换速率的一半
- 支持 10/12/14/16 倍串行化的低压差分信令 (LVDS) 输出
- 5Gbps JESD 接口：
 - 在 16 输入和 32 输入模式下受支持
 - JESD204B 子类 0、1 和 2
 - 每条 JESD 信道包含 2、4 或 8 条通道
- 可选的数字 I-Q 解调器 ⁽¹⁾
- 电源：1.2V、1.8V
- 2 V_{PP} 差分输入，0.8V 共模
- 差分或单端输入时钟
- 信噪比 (SNR)：
 - 10 位模式下为 61dBFS
 - 12 位模式下为 70dBFS
 - 14 位模式下为 73.5dBFS
- 100MSPS 转换速率下的功耗：41mW/通道
- 封装：NFBGA-198 (9mm x 15mm)
- 无铅（符合 RoHS 标准）绿色

2 应用

- 超声波成像
- 便携式仪表
- 声纳和雷达
- 高速多通道数据采集

3 说明

ADS52J90 是一款低功耗、高性能、16 通道的模数转换器 (ADC)。每个 ADC 在 10 位模式下的转换速率最高可达 100MSPS。ADC 分辨率越高，最高转换速率越低。

该器件可配置为接受 8、16 或 32 个输入。在 32 位模式下，每个 ADC 以值为 ADC 转换速率一半的有效采样率对两个不同输入交替进行采样并转换。在 8 位输入模式下，两个 ADC 以交错方式对同一输入进行转换，这种情况下的有效采样率为 ADC 转换速率的 2 倍。ADC 设计为根据转换速率调整其功耗。

器件信息

| 器件型号 | 封装 | 封装尺寸 (标称值) |
|----------|-------------|------------------|
| ADS52J90 | NFBGA (198) | 9.00mm x 15.00mm |

(1) 如需了解所有可用封装，请参阅数据表末尾的可订购产品附录。

简化原理图

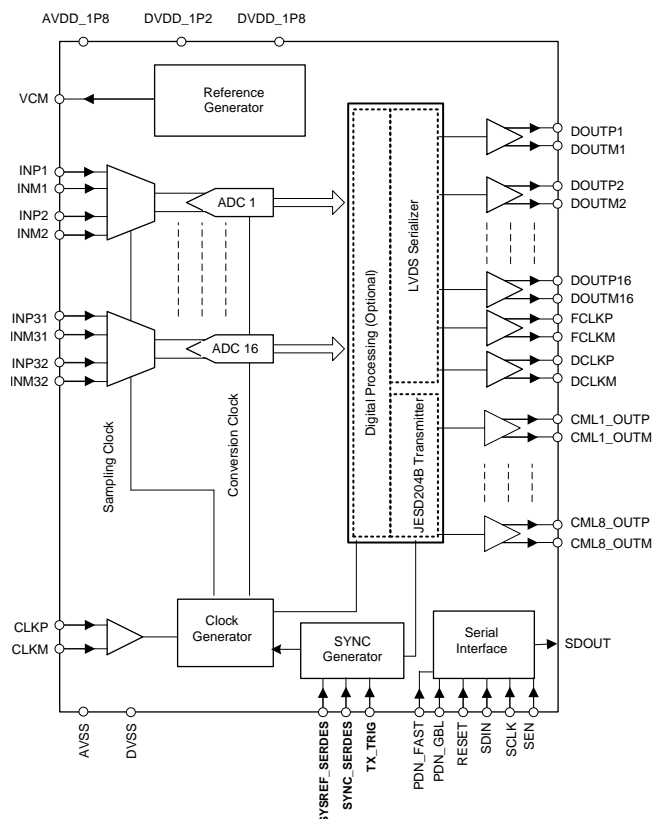

(1) 本文中未详细介绍。如需详细信息，请联系工厂。



目录

| | | | | | |
|----------|---|-----------|-----------|--|------------|
| 1 | 特性 | 1 | 8.4 | Device Functional Modes | 73 |
| 2 | 应用 | 1 | 8.5 | Programming | 76 |
| 3 | 说明 | 1 | 9 | Application and Implementation | 77 |
| 4 | 修订历史记录 | 2 | 9.1 | Application Information | 77 |
| 5 | 说明 (续) | 4 | 9.2 | Typical Application | 78 |
| 6 | Pin Configuration and Functions | 5 | 9.3 | Do's and Don'ts | 90 |
| 7 | Specifications | 9 | 10 | Power Supply Recommendations | 90 |
| 7.1 | Absolute Maximum Ratings | 9 | 10.1 | Power Sequencing and Initialization | 90 |
| 7.2 | ESD Ratings | 9 | 11 | Layout | 92 |
| 7.3 | Recommended Operating Conditions | 10 | 11.1 | Power Supply, Grounding, and Bypassing | 92 |
| 7.4 | Thermal Information | 10 | 11.2 | Layout Guidelines | 92 |
| 7.5 | Electrical Characteristics | 11 | 11.3 | Layout Example | 93 |
| 7.6 | Digital Characteristics | 13 | 12 | Register Map | 94 |
| 7.7 | Timing Requirements: Signal Chain | 14 | 12.1 | ADC Registers | 94 |
| 7.8 | Timing Requirements: JESD Interface | 15 | 12.2 | JESD Serial Interface Registers | 134 |
| 7.9 | Timing Requirements: Serial Interface | 15 | 13 | 器件和文档支持 | 149 |
| 7.10 | Typical Characteristics | 17 | 13.1 | 文档支持 | 149 |
| 7.11 | Typical Characteristics: JESD Interface | 24 | 13.2 | 社区资源 | 149 |
| 7.12 | Typical Characteristics: Contour Plots | 26 | 13.3 | 商标 | 149 |
| 8 | Detailed Description | 28 | 13.4 | 静电放电警告 | 149 |
| 8.1 | Overview | 28 | 13.5 | 术语表 | 149 |
| 8.2 | Functional Block Diagrams | 28 | 14 | 机械、封装和可订购信息 | 150 |
| 8.3 | Feature Description | 29 | | | |

4 修订历史记录

Changes from Revision B (August 2015) to Revision C

Page

| | |
|--|-----|
| • 已更改 <i>HPF_ROUND_ENABLE</i> register bit (register 15, bit 5) to <i>HPF_ROUND_EN_CH1-8</i> and <i>HPF_ROUND_EN_CH9-16</i> bits in last paragraph of <i>Digital HPF</i> section | 40 |
| • 已更改 <i>Masking of the Various Reset Operations Resulting from SYNC~ or SYSREF</i> table | 59 |
| • 已添加 <i>Interfacing SYNC~ and SYSREF Between the FPGA and ADCs</i> section | 65 |
| • 已更改 <i>Mapping of Analog Inputs to LVDS Outputs (8-Input Mode, 1X Data Rate)</i> table | 84 |
| • 已更改 <i>Mapping of Analog Inputs to LVDS Outputs (8-Input Mode, 2X Data Rate)</i> table | 85 |
| • 已更改 description for the value 001 in <i>Pattern Mode Bit Description</i> table | 99 |
| • 已更改 bit 5 from <i>HPF_ROUND_EN</i> to <i>HPF_ROUND_EN_CH1-8</i> in Register 15 | 109 |
| • 已更改 bit 5 from 0 to <i>HPF_ROUND_EN_CH9-16</i> in Register 2Dh | 123 |
| • 已更改 description for <i>JESD_RESET1</i> in Register 70 | 135 |
| • 已更改 description of <i>JESD_RESET2</i> and <i>JESD_RESET3</i> in Register 74 | 137 |

Changes from Revision A (June 2015) to Revision B

Page

| | |
|--|----|
| • 已更改文档标题以包含 LVDS 和 JESD 输出 | 1 |
| • 已添加 <i>JESD</i> 接口 可选解调器和 特性 要点 | 1 |
| • 更改简化原理图 | 1 |
| • 已添加 <i>JESD</i> 接口信息至说明 部分中添加了“概述”部分 | 4 |
| • Added footnote 1 to <i>Pin Functions</i> table | 6 |
| • Changed description of <i>SPI_DIG_EN</i> pin in <i>Pin Functions</i> table | 8 |
| • Changed title of <i>Current Consumption with LVDS Interface Enabled</i> section of <i>Electrical Characteristics</i> table | 12 |
| • Changed <i>Current Consumption with JESD Interface Enabled</i> section of <i>Electrical Characteristics</i> table | 12 |

| | |
|---|-----|
| • Added SPI_DIG_EN to <i>Digital Inputs</i> section title of <i>Digital Characteristics</i> table | 13 |
| • Changed V _{OC-CML} parameter name in <i>JESD Interface Timing Requirements</i> table | 15 |
| • Added 图 47 | 25 |
| • Added LVDS, JESD discussion to second paragraph of <i>Overview</i> section | 51 |
| • 添加了社区资源部分 | 149 |

Changes from Original (May 2015) to Revision A
Page

| | |
|--|----|
| • 已投入量产 | 1 |
| • 已更改 <i>Circuit to Level-Shift the Common-Mode Voltage From 1.2 V at the Driver Output to 0.7 V at the ADC Input</i> figure | 65 |
| • 已更改 <i>AC-Coupling Scheme for SYSREF</i> figure | 66 |

5 说明（续）

ADC 输出会进行串行化，并与帧时钟和高速位时钟一起通过低压差分信令 (LVDS) 接口输出。

该器件还具有一个可选的 JESD204B 接口，同时可在 16 输入和 32 输入模式下工作。该接口的运行速率最高可达 5Gbps。

ADS52J90 采用间距为 0.8mm 的 9mm × 15mm NFBGA-198 封装，额定工作温度范围为 -40°C 至 +85°C。

6 Pin Configuration and Functions

**ZZE Package
NFBGA-198 (15 mm × 9 mm)
Top View**

| | 1 | 2 | 3 | 4 | 5 | 6 | 7 | 8 | 9 | 10 | 11 |
|---|-------|-------|-------|----------|----------|------------|----------------|----------|-----------|-----------|-----------|
| A | INM2 | INP2 | INP1 | AVDD_1P8 | SDIN | RESET | DVDD_1P2 | DVSS | CML1_OUTP | CML1_OUTM | CML2_OUTP |
| B | INM3 | INP3 | INM1 | AVSS | SEN | SPI_DIG_EN | SCLK | DVDD_1P2 | DOUTP1 | DOUTM1 | CML2_OUTM |
| C | INM5 | INP5 | INP4 | AVSS | SDOUT | PDN_FAST | PDN_GBL | DVDD_1P2 | DOUTP2 | DOUTM2 | CML3_OUTP |
| D | INM6 | INP6 | INM4 | AVSS | NC | TX_TRIG | DVSS | DVDD_1P2 | DOUTP3 | DOUTM3 | CML3_OUTM |
| E | INM7 | INP7 | INM8 | INP8 | NC | AVDD_1P8 | DVSS | DVDD_1P8 | DOUTP4 | DOUTM4 | CML4_OUTP |
| F | INM9 | INP9 | INM10 | INP10 | VCM | AVDD_1P8 | DVDD_1P2 | DVDD_1P8 | DOUTP5 | DOUTM5 | CML4_OUTM |
| G | INM11 | INP11 | INM12 | INP12 | AVDD_1P8 | AVDD_1P8 | DVDD_1P2 | DVDD_1P8 | DOUTP6 | DOUTM6 | DOUTM8 |
| H | INM13 | INP13 | INM14 | INP14 | AVSS | AVSS | DVSS | DVSS | DOUTP7 | DOUTM7 | DOUTP8 |
| J | INM15 | INP15 | INM16 | INP16 | AVSS | AVSS | DVSS | DVSS | FCLKP | DVDD_1P8 | DCLKP |
| K | INM17 | INP17 | INM18 | INP18 | AVSS | AVSS | DVSS | DVSS | FCLKM | DVSS | DCLKM |
| L | INM19 | INP19 | INM20 | INP20 | AVSS | AVSS | DVSS | DVSS | DOUTP10 | DOUTM10 | DOUTP9 |
| M | INM21 | INP21 | INM22 | INP22 | AVDD_1P8 | AVDD_1P8 | DVDD_1P2 | DVDD_1P8 | DOUTP11 | DOUTM11 | DOUTM9 |
| N | INM23 | INP23 | INM24 | INP24 | NC | AVDD_1P8 | DVDD_1P2 | DVDD_1P8 | DOUTP12 | DOUTM12 | CML8_OUTM |
| P | INM25 | INP25 | INM26 | INP26 | NC | AVDD_1P8 | SYNCP_SERDES | DVDD_1P8 | DOUTP13 | DOUTM13 | CML8_OUTP |
| R | INM27 | INP27 | INM28 | AVSS | AVSS | DVSS | SYNCP_SERDES | DVDD_1P2 | DOUTP14 | DOUTM14 | CML7_OUTM |
| T | INM29 | INP29 | INP28 | AVSS | AVSS | DVDD_1P2 | SYSREFM_SERDES | DVDD_1P2 | DOUTP15 | DOUTM15 | CML7_OUTP |
| U | INM30 | INP30 | INM32 | AVSS | CLKM | AVSS | SYSREFP_SERDES | DVDD_1P2 | DOUTP16 | DOUTM16 | CML6_OUTM |
| V | INM31 | INP31 | INP32 | AVDD_1P8 | CLKP | AVSS | DVDD_1P2 | DVSS | CML5_OUTP | CML5_OUTM | CML6_OUTP |

Pin Functions⁽¹⁾

| PIN | | I/O | DESCRIPTION |
|-----------|--|-----|---|
| NAME | NO. | | |
| AVDD_1P8 | A4, E6, F6, G5, G6, M5, M6, N6, P6, V4 | P | 1.8-V analog supply voltage |
| AVSS | B4, C4, D4, H5, H6, J5, J6, K5, K6, L5, L6, R4, R5, T4, T5, U4, U6, V6 | G | Analog ground |
| CLKM | U5 | I | Differential clock input pins. A single-ended clock is also supported. See the Clock Input section for further details. |
| CLKP | V5 | | |
| CML1_OUTM | A10 | O | JESD output lane 1 |
| CML1_OUTP | A9 | | |
| CML2_OUTM | B11 | O | JESD output lane 2 |
| CML2_OUTP | A11 | | |
| CML3_OUTM | D11 | O | JESD output lane 3 |
| CML3_OUTP | C11 | | |
| CML4_OUTM | F11 | O | JESD output lane 4 |
| CML4_OUTP | E11 | | |
| CML5_OUTM | V10 | O | JESD output lane 5 |
| CML5_OUTP | V9 | | |
| CML6_OUTM | U11 | O | JESD output lane 6 |
| CML6_OUTP | V11 | | |
| CML7_OUTM | R11 | O | JESD output lane 7 |
| CML7_OUTP | T11 | | |
| CML8_OUTM | N11 | O | JESD output lane 8 |
| CML8_OUTP | P11 | | |
| DCLKM | K11 | O | LVDS bit clock output |
| DCLKP | J11 | | |
| DOUM1 | B10 | O | LVDS data lane 1 |
| DOUP1 | B9 | | |
| DOUM2 | C10 | O | LVDS data lane 2 |
| DOUP2 | C9 | | |
| DOUM3 | D10 | O | LVDS data lane 3 |
| DOUP3 | D9 | | |
| DOUM4 | E10 | O | LVDS data lane 4 |
| DOUP4 | E9 | | |
| DOUM5 | F10 | O | LVDS data lane 5 |
| DOUP5 | F9 | | |
| DOUM6 | G10 | O | LVDS data lane 6 |
| DOUP6 | G9 | | |
| DOUM7 | H10 | O | LVDS data lane 7 |
| DOUP7 | H9 | | |
| DOUM8 | G11 | O | LVDS data lane 8 |
| DOUP8 | H11 | | |
| DOUM9 | M11 | O | LVDS data lane 9 |
| DOUP9 | L11 | | |
| DOUM10 | L10 | O | LVDS data lane 10 |
| DOUP10 | L9 | | |
| DOUM11 | M10 | O | LVDS data lane 11 |
| DOUP11 | M9 | | |
| DOUM12 | N10 | O | LVDS data lane 12 |
| DOUP12 | N9 | | |

(1) If the JESD interface is not used, then do not connect the CMLx, SYNCx, and SYSREFx pins. If the LVDS interface is not used, then do not connect DOUTx, DCLKx, and FCLKx.

Pin Functions⁽¹⁾ (continued)

| PIN | | I/O | DESCRIPTION |
|----------|---|-----|--|
| NAME | NO. | | |
| DOUTM13 | P10 | O | LVDS data lane 13 |
| DOUTP13 | P9 | | |
| DOUTM14 | R10 | O | LVDS data lane 14 |
| DOUTP14 | R9 | | |
| DOUTM15 | T10 | O | LVDS data lane 15 |
| DOUTP15 | T9 | | |
| DOUTM16 | U10 | O | LVDS data lane 16 |
| DOUTP16 | U9 | | |
| DVDD_1P2 | A7, B8, C8, D8, F7, G7, M7, N7, R8, T6, T8, U8, V7 | P | 1.2-V digital supply voltage |
| DVDD_1P8 | E8, F8, G8, J10, M8, N8, P8 | P | 1.8-V digital supply voltage |
| DVSS | A8, D7, E7, H7, H8, J7, J8, K7, K8, K10, L7, L8, R6, V8 | G | Digital ground |
| FCLKM | K9 | O | LVDS frame clock output |
| FCLKP | J9 | | |
| INM1 | B3 | I | Differential analog input 1 pins; see 表 1 for mapping to external inputs in 8-, 16-, and 32-input modes |
| INP1 | A3 | | |
| INM2 | A1 | I | Differential analog input 2 pins; see 表 1 for mapping to external inputs in 8-, 16-, and 32-input modes |
| INP2 | A2 | | |
| INM3 | B1 | I | Differential analog input 3 pins; see 表 1 for mapping to external inputs in 8-, 16-, and 32-input modes |
| INP3 | B2 | | |
| INM4 | D3 | I | Differential analog input 4 pins; see 表 1 for mapping to external inputs in 8-, 16-, and 32-input modes |
| INP4 | C3 | | |
| INM5 | C1 | I | Differential analog input 5 pins; see 表 1 for mapping to external inputs in 8-, 16-, and 32-input modes |
| INP5 | C2 | | |
| INM6 | D1 | I | Differential analog input 6 pins; see 表 1 for mapping to external inputs in 8-, 16-, and 32-input modes |
| INP6 | D2 | | |
| INM7 | E1 | I | Differential analog input 7 pins; see 表 1 for mapping to external inputs in 8-, 16-, and 32-input modes |
| INP7 | E2 | | |
| INM8 | E3 | I | Differential analog input 8 pins; see 表 1 for mapping to external inputs in 8-, 16-, and 32-input modes |
| INP8 | E4 | | |
| INM9 | F1 | I | Differential analog input 9 pins; see 表 1 for mapping to external inputs in 8-, 16-, and 32-input modes |
| INP9 | F2 | | |
| INM10 | F3 | I | Differential analog input 10 pins; see 表 1 for mapping to external inputs in 8-, 16-, and 32-input modes |
| INP10 | F4 | | |
| INM11 | G1 | I | Differential analog input 11 pins; see 表 1 for mapping to external inputs in 8-, 16-, and 32-input modes |
| INP11 | G2 | | |
| INM12 | G3 | I | Differential analog input 12 pins; see 表 1 for mapping to external inputs in 8-, 16-, and 32-input modes |
| INP12 | G4 | | |
| INM13 | H1 | I | Differential analog input 13 pins; see 表 1 for mapping to external inputs in 8-, 16-, and 32-input modes |
| INP13 | H2 | | |
| INM14 | H3 | I | Differential analog input 14 pins; see 表 1 for mapping to external inputs in 8-, 16-, and 32-input modes |
| INP14 | H4 | | |
| INM15 | J1 | I | Differential analog input 15 pins; see 表 1 for mapping to external inputs in 8-, 16-, and 32-input modes |
| INP15 | J2 | | |
| INM16 | J3 | I | Differential analog input 16 pins; see 表 1 for mapping to external inputs in 8-, 16-, and 32-input modes |
| INP16 | J4 | | |
| INM17 | K1 | I | Differential analog input 17 pins; see 表 1 for mapping to external inputs in 8-, 16-, and 32-input modes |
| INP17 | K2 | | |

Pin Functions⁽¹⁾ (continued)

| PIN | | I/O | DESCRIPTION |
|--------------|----------------|-----|--|
| NAME | NO. | | |
| INM18 | K3 | I | Differential analog input 18 pins; see 表 1 for mapping to external inputs in 8-, 16-, and 32-input modes |
| INP18 | K4 | | |
| INM19 | L1 | I | Differential analog input 19 pins; see 表 1 for mapping to external inputs in 8-, 16-, and 32-input modes |
| INP19 | L2 | | |
| INM20 | L3 | I | Differential analog input 20 pins; see 表 1 for mapping to external inputs in 8-, 16-, and 32-input modes |
| INP20 | L4 | | |
| INM21 | M1 | I | Differential analog input 21 pins; see 表 1 for mapping to external inputs in 8-, 16-, and 32-input modes |
| INP21 | M2 | | |
| INM22 | M3 | I | Differential analog input 22 pins; see 表 1 for mapping to external inputs in 8-, 16-, and 32-input modes |
| INP22 | M4 | | |
| INM23 | N1 | I | Differential analog input 23 pins; see 表 1 for mapping to external inputs in 8-, 16-, and 32-input modes |
| INP23 | N2 | | |
| INM24 | N3 | I | Differential analog input 24 pins; see 表 1 for mapping to external inputs in 8-, 16-, and 32-input modes |
| INP24 | N4 | | |
| INM25 | P1 | I | Differential analog input 25 pins; see 表 1 for mapping to external inputs in 8-, 16-, and 32-input modes |
| INP25 | P2 | | |
| INM26 | P3 | I | Differential analog input 26 pins; see 表 1 for mapping to external inputs in 8-, 16-, and 32-input modes |
| INP26 | P4 | | |
| INM27 | R1 | I | Differential analog input 27 pins; see 表 1 for mapping to external inputs in 8-, 16-, and 32-input modes |
| INP27 | R2 | | |
| INM28 | R3 | I | Differential analog input 28 pins; see 表 1 for mapping to external inputs in 8-, 16-, and 32-input modes |
| INP28 | T3 | | |
| INM29 | T1 | I | Differential analog input 29 pins; see 表 1 for mapping to external inputs in 8-, 16-, and 32-input modes |
| INP29 | T2 | | |
| INM30 | U1 | I | Differential analog input 30 pins; see 表 1 for mapping to external inputs in 8-, 16-, and 32-input modes |
| INP30 | U2 | | |
| INM31 | V1 | I | Differential analog input 31 pins; see 表 1 for mapping to external inputs in 8-, 16-, and 32-input modes |
| INP31 | V2 | | |
| INM32 | U3 | I | Differential analog input 32 pins; see 表 1 for mapping to external inputs in 8-, 16-, and 32-input modes |
| INP32 | V3 | | |
| NC | D5, E5, N5, P5 | — | Do not connect; leave floating. |
| PDN_FAST | C6 | I | Fast power-down control pin (active high) with an internal pulldown resistor of 20 kΩ. For active high, a 1.8-V logic level is recommended. |
| PDN_GBL | C7 | I | Global power-down control input (active high) with an internal pulldown resistor of 20 kΩ. For active high, a 1.8-V logic level is recommended. |
| SPI_DIG_EN | B6 | I | Reserved for digital functionality. This pin can be left floating or be connected to the 1.8-V supply. This pin has an internal pullup resistor of 20 kΩ. |
| RESET | A6 | I | Hardware reset pin (active high) with an internal pulldown resistor of 20 kΩ. For active high, a 1.8-V logic level is recommended. |
| SCLK | B7 | I | Serial interface clock input with an internal pulldown resistor of 20 kΩ. For active high, a 1.8-V logic level is recommended. |
| SDIN | A5 | I | Serial interface data input with an internal pulldown resistor of 20 kΩ. For active high, a 1.8-V logic level is recommended. |
| SDOUT | C5 | O | Serial interface data readout. High impedance when readout is disabled. 1.8-V logic level is recommended. |
| SEN | B5 | I | Serial interface enable with an internal pullup resistor of 20 kΩ. 1.8-V logic level is recommended. |
| TX_TRIG | D6 | I | 1.8-V logic; a pulse on TX_TRIG must be applied after power-up to ensure that all internal clock dividers are synchronized ⁽²⁾ . Has an internal pull-down resistor of 20 kΩ to ground. |
| SYNCP_SERDES | R7 | I | Frame synchronization input as per JESD204B standard |
| SYNCM_SERDES | P7 | | |

(2) See the [Device Synchronization Using TX_TRIG](#) section for more details on synchronization using TX_TRIG.

Pin Functions⁽¹⁾ (continued)

| PIN | | I/O | DESCRIPTION |
|----------------|-----|-----|--|
| NAME | NO. | | |
| SYSREFM_SERDES | T7 | I | Frame clock and local multiframe clock (LMFC) synchronization input as per JESD204B, subclass 1 standard |
| SYSREFP_SERDES | U7 | | |
| VCM | F5 | O | Common-mode output pin for biasing analog input signals. Connect a 10- μ F capacitor to ground. |

7 Specifications

7.1 Absolute Maximum Ratings

over operating free-air temperature range (unless otherwise noted)⁽¹⁾

| | | MIN | MAX | UNIT |
|---|--|------|---------------------------------|------|
| Voltage | AVDD_1P8 | -0.3 | 2.2 | V |
| | DVDD_1P2 | -0.3 | 1.35 | |
| | DVDD_1P8 | -0.3 | 2.2 | |
| Analog input pins (INM _i , INP _i) | | -0.3 | Minimum [2.2, (AVDD_1P8 + 0.3)] | V |
| CLKP, CLKM | | -0.3 | Minimum [2.2, (AVDD_1P8 + 0.3)] | V |
| Digital control pins | PDN_GBL, PDN_FAST, RESET, SCLK, SDIN, SEN, TX_TRIG, SPI_DIG_EN, SYNCM_SERDES, SYNCP_SERDES, SYSREFM_SERDES, SYSREFP_SERDES | -0.3 | Minimum [2.2, (DVDD_1P8 + 0.3)] | V |
| Maximum operating junction temperature, T _{JMax} | | | 105 | °C |
| Storage temperature, T _{stg} | | -55 | 150 | °C |

(1) Stresses beyond those listed under *Absolute Maximum Ratings* may cause permanent damage to the device. These are stress ratings only, which do not imply functional operation of the device at these or any other conditions beyond those indicated under *Recommended Operating Conditions*. Exposure to absolute-maximum-rated conditions for extended periods may affect device reliability.

7.2 ESD Ratings

| | | VALUE | UNIT |
|--------------------|-------------------------|--|-------|
| V _(ESD) | Electrostatic discharge | Human body model (HBM), per ANSI/ESDA/JEDEC JS-001 ⁽¹⁾ | ±1000 |
| | | Charged device model (CDM), per JEDEC specification JESD22-C101 ⁽²⁾ | ±250 |

(1) JEDEC document JEP155 states that 500-V HBM allows safe manufacturing with a standard ESD control process.

(2) JEDEC document JEP157 states that 250-V CDM allows safe manufacturing with a standard ESD control process.

7.3 Recommended Operating Conditions

| PARAMETER | TEST CONDITIONS | MIN | NOM | MAX | UNIT |
|---------------------------------------|---|--------------------------------------|------|-----------------|-----------------|
| TEMPERATURE | | | | | |
| T _A | Ambient | -40 | | 85 | °C |
| SUPPLIES | | | | | |
| V _(AVDD_1P8) | 1.8-V analog supply voltage | 1.7 | 1.8 | 1.9 | V |
| V _(DVDD_1P8) | 1.8-V digital supply voltage | 1.7 | 1.8 | 1.9 | V |
| V _(DVDD_1P2) | 1.2-V digital supply voltage | 1.15 | 1.2 | 1.25 | V |
| ANALOG INPUT | | | | | |
| V _(INX) | Voltage range at analog input pins | VCM - 0.5 | | VCM + 0.5 | V |
| V _{(IN(CM))} | Input common-mode range at analog input pins | 0.7 | 0.8 | 0.9 | V |
| V _{(IN(FS))} | Input differential full-scale voltage | | 2 | | V _{PP} |
| F _{IN} | Analog input frequency range ⁽¹⁾ | 0 | | 70 | MHz |
| ANALOG OUTPUT | | | | | |
| I _(VCM) | External loading on VCM pin | ±50-mV change in VCM | | 100 | μA |
| CLOCK INPUT | | | | | |
| f _S | System clock frequency | 16-input mode, 10-bit ADC resolution | 5 | 100 | MSPS |
| | | 16-input mode, 12-bit ADC resolution | 5 | 80 | |
| | | 16-input mode, 14-bit ADC resolution | 5 | 65 | |
| | | 32-input mode, 10-bit ADC resolution | 5 | 100 | |
| | | 32-input mode, 12-bit ADC resolution | 5 | 80 | |
| | | 32-input mode, 14-bit ADC resolution | 5 | 65 | |
| | | 8-input mode, 10-bit ADC resolution | 10 | 200 | |
| V _{CLKP} - V _{CLKM} | Differential clock amplitude | Sine-wave, ac-coupled | 0.7 | | V _{PP} |
| | | LVPECL, ac-coupled | | 1.6 | |
| | | LVDS, ac-coupled | 0.35 | 0.7 | |
| V _{CLKP} | Single-ended clock amplitude | LVCMOS on CLKP with CLKM grounded | | 1.8 | V _{PP} |
| | Input clock duty cycle | 40% | 50% | 60% | |
| DIGITAL INPUTS | | | | | |
| V _{IH} | Digital input minimum, high level | 0.75 × DVDD_1P8 | 1.8 | | V |
| V _{IL} | Digital input maximum, low level | | 0 | 0.25 × DVDD_1P8 | V |
| DIGITAL OUTPUT (LVDS) | | | | | |
| R _{LOAD} | Differential load resistance | Between DOUTP and DOUTM | | 100 | Ω |
| DIGITAL OUTPUT (CML) | | | | | |
| R _{CML} | Load resistance from each CML output to a common mode | | 50 | | Ω |

(1) Performance degradation may be seen at high input frequencies.

7.4 Thermal Information

| THERMAL METRIC ⁽¹⁾ | ADS52J90 | UNITS | |
|-------------------------------|--|-------|------|
| | ZZE (NFBGA) | | |
| | 198 PINS | | |
| R _{θJA} | Junction-to-ambient thermal resistance | 33.7 | °C/W |
| R _{θJC(top)} | Junction-to-case (top) thermal resistance | 4.9 | °C/W |
| R _{θJB} | Junction-to-board thermal resistance | 14.1 | °C/W |
| ψ _{JT} | Junction-to-top characterization parameter | 0.1 | °C/W |
| ψ _{JB} | Junction-to-board characterization parameter | 14.1 | °C/W |
| R _{θJC(bot)} | Junction-to-case (bottom) thermal resistance | N/A | °C/W |

(1) For more information about traditional and new thermal metrics, see the *IC Package Thermal Metrics* application report, [SPRA953](#).

7.5 Electrical Characteristics

Typical values are across ADC resolution and input modes, unless otherwise specified. Typical values are at 25°C, AVDD_1P8 = DVDD_1P8 = 1.8 V, DVDD_1P2 = 1.2 V. External 100-Ω differential load between LVDS outputs, 4-pF load capacitor from each LVDS output to ground, and 1X data rate mode.

All ADCs are powered up and the input signal is a –1-dBFS tone at 5 MHz applied on one channel at a time.

| PARAMETER | | TEST CONDITIONS | MIN | TYP | MAX | UNIT |
|--|--|--|------|----------------------|-----|------|
| ADC | | | | | | |
| N _{adc} | ADC resolution | 32-channel input, 16-channel input | 10 | | 14 | Bits |
| | | 8-channel input | | 10 | | |
| | Number of ADCs | | | 16 | | ADCs |
| CLOCK DOMAINS | | | | | | |
| f _C | Conversion rate of each ADC (conversion clock frequency) | 10-bit ADC resolution | | | 100 | MSPS |
| | | 12-bit ADC resolution | | | 80 | |
| | | 14-bit ADC resolution | | | 65 | |
| f _S | System clock frequency in terms of f _C | 16-input mode | | f _C | | MSPS |
| | | 32-input mode | | f _C | | |
| | | 8-input mode | | 2 × f _C | | |
| f _{SAMP} | Effective sampling rate of each input channel in terms of f _C | 16-input mode | | f _C | | MSPS |
| | | 32-input mode | | 0.5 × f _C | | |
| | | 8-input mode | | 2 × f _C | | |
| PERFORMANCE | | | | | | |
| G _{MATCH} | Gain matching | Same device, across channels | | ±0.1 | | dB |
| | | Same channel, across devices | | ±0.1 | | |
| G _{DRIFT} | Gain drift with temperature over full temperature range | | | 0.1 | | dB |
| V _{OFF} | Offset error | | | –7 to 7 | | mV |
| DNL | Differential nonlinearity of the ADC | 10-bit resolution | | –0.5 to 0.5 | | LSB |
| | | 12-bit resolution | | –0.9 to 0.9 | | |
| | | 14-bit resolution | | –1 to 2 | | |
| INL | Integral nonlinearity of the ADC | 10-bit resolution | | –0.5 to 0.5 | | LSB |
| | | 12-bit resolution | | –1 to 1 | | |
| | | 14-bit resolution | | –3 to 3 | | |
| SNR | Signal-to-noise ratio: excludes first 9 harmonics as well as spurs at (f _S / 2 ± f _{IN}), (f _S / 4 ± f _{IN}), f _S / 2, and f _S / 4 | 10-bit, 16-channel input mode, f _{SAMP} = 100 MSPS | | 61.3 | | dBFS |
| | | 10-bit, 32-channel input mode, f _{SAMP} = 50 MSPS | | 61.3 | | |
| | | 10-bit mode, 8-channel input, f _{SAMP} = 200 MSPS | 56 | 60 | | |
| | | 10-bit mode, 8-channel input, f _{SAMP} = 130 MSPS | 58.2 | 61 | | |
| | | 12-bit mode, 16-channel input, f _{SAMP} = 80 MSPS | | 69.5 | | |
| | | 12-bit mode, 32-channel input, f _{SAMP} = 40 MSPS | 65 | 69.5 | | |
| | | 12-bit mode, 32-channel input, f _{SAMP} = 20 MSPS | 67.5 | 70.2 | | |
| | | 14-bit mode, 16-channel input, f _{SAMP} = 65 MSPS | 65.9 | 72.5 | | |
| 14-bit mode, 16-channel input, f _{SAMP} = 50 MSPS | 67.9 | 73.5 | | | | |
| 14-bit mode, 32-channel input, f _{SAMP} = 32.5 MSPS | | 73 | | | | |
| HD2 | Second-order harmonic distortion | All input modes and resolutions | | –80 | | dBc |
| HD3 | Third-order harmonic distortion | All input modes and resolutions | | –80 | | dBc |
| THD | Total harmonic distortion | All input modes and resolutions | | –76 | | dBc |
| | Magnitude of spur at (f _S / 2 ± f _{IN}) | 16-input mode; 10-, 12-, 14-bit resolutions | | –73 | | dBc |
| | | 8-input mode, 10-bit resolution | | –62 | | |
| | Magnitude of spur at (f _S / 4 ± f _{IN}) | 8-input mode, 10-bit resolution | | –65 | | dBc |
| | Crosstalk | Input spur on neighboring channel with one channel excited at 5 MHz, –1 dBFS | | –80 | | dBc |

Electrical Characteristics (continued)

Typical values are across ADC resolution and input modes, unless otherwise specified. Typical values are at 25°C, AVDD_1P8 = DVDD_1P8 = 1.8 V, DVDD_1P2 = 1.2 V. External 100-Ω differential load between LVDS outputs, 4-pF load capacitor from each LVDS output to ground, and 1X data rate mode.

All ADCs are powered up and the input signal is a –1-dBFS tone at 5 MHz applied on one channel at a time.

| PARAMETER | | TEST CONDITIONS | MIN | TYP | MAX | UNIT |
|--|---|--|-----|------|-----|-------------------|
| PERFORMANCE (continued) | | | | | | |
| PSRR _{100kHz} | AC power-supply rejection ratio: tone at output relative to tone on supply | 100-mV _{PP} , 100-kHz tone on supply | | –70 | | dBc |
| PSMR _{100kHz} | AC power-supply modulation ratio: intermodulation tone at output resulting from tones at supply and input measured relative to input tone | 100-mV _{PP} , 100-kHz tone on supply and –1-dBFS, 5-MHz tone on input | | –80 | | dBc |
| CMRR | AC common-mode rejection ratio: tone at output relative to the common-mode tone applied at the analog input pins | 50-mV _{PP} common-mode tone at input pins with a frequency of 5 MHz | | –40 | | dBc |
| TRANSIENT BEHAVIOR | | | | | | |
| N _{OVERLOAD} | Input overload recovery | 5-MHz overload input, 6-dBFS overload | | 1 | | Conversion clock |
| t _{PDN_GBL} | Recovery time from global power-down mode | PDN_GBL from high to low | | 1 | | ms |
| t _{PDN_FAST} | Recovery time from fast power-down mode (standby mode) | PDN_FAST from high to low | | 15 | | Conversion clocks |
| CURRENT CONSUMPTION WITH LVDS INTERFACE ENABLED | | | | | | |
| | Current consumption in global power-down mode (PDN_GBL = 1) | AVDD_1P8 current | | 3 | | mA |
| | | DVDD_1P8 current | | 3 | | |
| | | DVDD_1P2 current | | 25 | | |
| | Current consumption in standby mode (PDN_FAST = 1) at f _C = 100 MSPS | AVDD_1P8 current | | 80 | | mA |
| | | DVDD_1P8 current | | 35 | | |
| | | DVDD_1P2 current | | 70 | | |
| | Current consumption in active mode at f _C = 100 MSPS ⁽¹⁾ | AVDD_1P8 current | | 190 | | mA |
| | | DVDD_1P8 current | | 100 | | |
| | | DVDD_1P2 current | | 110 | | |
| P _{CH} | Power dissipation in active mode per input channel at f _C = 100 MSPS | 16-channel input mode | | 41 | | mW/channel |
| | | 32-channel input mode | | 20.5 | | |
| | | 8-channel input mode | | 82 | | |
| CURRENT CONSUMPTION WITH JESD INTERFACE ENABLED | | | | | | |
| I _{JESD} | Supply currents: JESD204B interface enabled, LVDS interface disabled at 12-bit, 80-MSPS, 4 ADCs per lane mode | AVDD_1P8 current ⁽¹⁾ | | 170 | | mA |
| | | DVDD_1P2 current ⁽¹⁾ | | 260 | | |
| | | DVDD_1P8 current ⁽¹⁾ | | 40 | | |
| P _{JESD_CH} | Power dissipation in active mode per input channel: f _C = 80 MSPS, 12-bit mode, LVDS interface disabled, JESD interface enabled (4 ADCs per lane mode) | 16-channel input mode | | 43.1 | | mW/channel |
| | | 32-channel input mode | | 21.6 | | |

(1) See the [Power Supply Recommendations](#) section for guidelines on designing the supplies.

7.6 Digital Characteristics

The dc specifications refer to the condition where the digital outputs are not switching, but are permanently at a valid logic level 0 or 1. Typical values are at 25°C, AVDD_1P8 = DVDD_1P8 = 1.8 V, DVDD_1P2 = 1.2 V, and external differential load resistance between the LVDS output pair ($R_{LOAD} = 100 \Omega$), unless otherwise noted.

| PARAMETER | | TEST CONDITIONS | MIN | TYP | MAX | UNIT |
|--|---|---|------|------|------|------|
| DIGITAL INPUTS (PDN_FAST, PDN_GBL, RESET, SCLK, SDIN, SEN, TX_TRIG, SPI_DIG_EN) | | | | | | |
| V _{IH} | High-level input voltage | | 1.35 | | | V |
| V _{IL} | Low-level input voltage | | | | 0.45 | V |
| I _{IH} | High-level input current | | | 150 | | μA |
| I _{IL} | Low-level input current | | | 150 | | μA |
| C _i | Input capacitance | | | 4 | | pF |
| DIGITAL OUTPUTS (SDOUT) | | | | | | |
| V _{OH} | High-level output voltage | | 1.6 | 1.8 | | V |
| V _{OL} | Low-level output voltage | | | 0 | 0.2 | V |
| z _o | Output impedance | | | 50 | | Ω |
| LVDS DIGITAL OUTPUTS (DOUTPI, DOUTMI)⁽¹⁾ | | | | | | |
| V _{OD} | Output differential voltage | 100-Ω external load connected differentially across DOUTP ₁ and DOUTM ₁ | 320 | 400 | 480 | mV |
| V _{OS} | Output offset voltage (common-mode voltage of DOUTP ₁ and DOUTM ₁) | 100-Ω external load connected differentially across DOUTP ₁ and DOUTM ₁ | 0.9 | 1.03 | 1.15 | V |

(1) All digital specifications are characterized across operating temperature range but are not tested at production.

7.7 Timing Requirements: Signal Chain

Typical values are at 25°C. AVDD_1P8 = DVDD_1P8 = 1.8 V, DVDD_1P2 = 1.2 V, and external differential load resistance between the LVDS output pair ($R_{LOAD} = 100 \Omega$), unless otherwise noted. A capacitive load of 4 pF is on the LVDS outputs.

| | | MIN | TYP | MAX | UNIT |
|-----------------------|--|----------------------------|-------------------------------|---------------------------------|-------------------|
| GENERAL | | | | | |
| t_{AP} | Aperture delay | | 1.6 | | ns |
| δt_{AP} | Aperture delay variation from device to device (at same temperature and supply) | | ± 0.5 | | ns |
| t_{APJ} | Aperture jitter with LVPECL clock as input clock | | 0.5 | | ps |
| ADC TIMING | | | | | |
| N_{LAT} | ADC latency | Default after reset | 8.5 | | Conversion clocks |
| | | Low-latency mode | 4.5 | | |
| LVDS TIMING | | | | | |
| f_F | Frame clock frequency | 16-input and 8-input modes | f_C | | MHz |
| | | 32-input mode | $f_C / 2$ | | |
| D_{FRAME} | Frame clock duty cycle | | 50% | | |
| N_{SER} | Number of bits serialization of each ADC word | 10 | | 16 | Bits |
| f_D | Output rate of serialized data for 1X output data rate mode, 16-, 8-, and 32-input modes | | $N_{SER} \times f_C$ | 1000 | Mbps |
| | Output rate of serialized data for 2X output data rate mode, 16-input and 8-input modes | | $2 \times N_{SER} \times f_C$ | 1000 | |
| f_B | Bit clock frequency | | $f_D / 2$ | 500 | MHz |
| D_{BIT} | Bit clock duty cycle | | 50% | | |
| t_D | Data bit duration | 1 | $1000 / f_D$ | | ns |
| t_{PROP} | Clock propagation delay ⁽¹⁾ | | $6 \times t_D + 5$ | | ns |
| δt_{PROP} | Clock propagation delay variation from device to device (at same temperature and supply) | | ± 2 | | ns |
| t_{ORF} | DOUT, DCLK, FCLK rise and fall time, transition time between -100 mV and +100 mV | | 0.2 | | ns |
| t_{OSU} | Minimum serial data, serial clock setup time ⁽²⁾ | | $t_D / 2 - 0.4$ | | ns |
| t_{OH} | Minimum serial data, serial clock hold time ⁽²⁾ | | $t_D / 2 - 0.4$ | | ns |
| t_{DV} | Minimum data valid window ⁽³⁾⁽²⁾ | | $t_D - 0.65$ | | ns |
| TX_TRIG TIMING | | | | | |
| $t_{TX_TRIG_DEL}$ | Delay between TX_TRIG and TX_TRIGD ⁽⁴⁾ | 0.5 | | $0.4 \times t_S$ ⁽⁵⁾ | ns |
| $t_{SU_TX_TRIGD}$ | Setup time related to latching TX_TRIG relative to the rising edge of the system clock | | 0.6 | | ns |
| $t_{H_TX_TRIGD}$ | Hold time related to latching TX_TRIG relative to the rising edge of the system clock | | 0.4 | | ns |

(1) See [Figure 64](#) to [Figure 68](#) for the definition of t_{PROP} in various operating modes.

(2) See [Figure 1](#).

(3) The specification for the minimum data valid window is larger than the sum of the minimum setup and hold times because there can be a skew between the ideal transitions of the serial output data with respect to the transition of the bit clock. This skew can vary across channels and across devices. A mechanism to correct this skew can therefore improve the setup and hold timing margins. For example, the LVDS_DCLK_DELAY_PROG control can be used to shift the relative timing of the bit clock with respect to the data.

(4) TX_TRIGD is the internally delayed version of TX_TRIG that gets latched on the rising edge of the system clock.

(5) t_S is the system clock period in ns.

7.8 Timing Requirements: JESD Interface

Typical values are at $T_A = 25^\circ\text{C}$, $AVDD_1P8 = 1.8\text{ V}$, $DVDD_1P2 = 1.2\text{ V}$, $DVDD_1P8 = 1.8\text{ V}$, differential ADC clock, $R_{LOAD} = 50\ \Omega$ from each CML pin to $DVDD_1P2$, 12-bit ADC resolution, sample rate, and $f_C = 80\text{ MSPS}$, unless otherwise noted. Minimum and maximum values are across the full temperature range of $T_{MIN} = -40^\circ\text{C}$ to $T_{MAX} = 85^\circ\text{C}$. The JESD204B interface operates in default mode after setting the JESD_EN bit to 1 (12-bit ADC resolution, 12-bit serialization, 4 ADCs per lane, and scrambling disabled).

| | | MIN | TYP | MAX | UNIT |
|-------------------------------|--|----------------------------|-------------------|------|---------------------|
| TIMING CHARACTERISTICS | | | | | |
| f_{JESD} | Serial output data rate in terms of F (number of octets per frame) and f_C (ADC clock frequency in MHz) | $0.01 \times F \times f_C$ | | | Gbps |
| UI | Unit interval | 200 | $1000 / f_{JESD}$ | 2000 | ps |
| Tj | Total jitter: $f_{JESD} = 5\text{ Gbps}$, PRE_EMP = 7, INC_JESD_VDD = 1 | 0.27 | | | p-p UI |
| t_R, t_F | Rise and fall time: 20% to 80%, each pin loaded by $C_{LOAD} = 1.2\text{ pF}$ to $DVDD_1P2$ | 85 | | | ps |
| SAMPLING TIMING | | | | | |
| t_{SU_S} | Setup time for SYSREF with respect to the device clock rising edge | 3 | | | ns |
| t_{H_S} | Hold time for SYSREF with respect to the device clock rising edge | 2 | | | ns |
| t_{SU_T} | Setup time for SYNC~ with respect to the device clock rising edge | 3 | | | ns |
| t_{H_T} | Hold time for SYNC~ with respect to the device clock rising edge | 2 | | | ns |
| JESD LATENCY | | | | | |
| N_{A_SYNC-} | Latency from SYNC~ assertion (falling) edge to start of CGS phase (K28.5) in subclass 0, 1, and 2 | 17 | | | Device clock cycles |
| N_{D_SYNC-} | Latency from the first LMFC boundary after SYNC~ deassertion (rising) edge to start of ILA phase (K28.0) in subclass 1 | 11 | | | Device clock cycles |
| N_{LAT_JESD} | Latency from the device clock falling edge sampling the analog input of ADC1 to the appearance of the corresponding octets on the JESD outputs | 14.5 | | | Device clock cycles |
| JESD DIGITAL OUTPUTS | | | | | |
| V_{OH_CML} | High-level output voltage of the CML output (CMLx_OUTP, CMLx_OUTM) | DVDD_1P2 | | | V |
| V_{OL_CML} | Low-level output voltage of the CML output (CMLx_OUTP, CMLx_OUTM) | DVDD_1P2 – 0.4 | | | V |
| $ V_{OD_CML} $ | Differential output voltage of CMLx_OUT | 0.4 | | | V |
| V_{OC_CML} | Common-mode output voltage of CMLx_OUTP, CMLx_OUTM | DVDD_1P2 – 0.2 | | | V |
| Z_{OS} | Single-ended output impedance | $50 \pm 25\%$ | | | Ω |
| C_{CML} | Output capacitance inside device from either CML output to ground | 1 | | | pF |
| | Transmitter short-circuit current: transmitter terminals shorted to any voltage between –0.25 V and 1.45 V | ± 100 | | | mA |

7.9 Timing Requirements: Serial Interface⁽¹⁾⁽²⁾

| | | MIN | TYP | MAX | UNIT |
|---------------|---|-----|-----|-----|------|
| t_{SCLK} | SCLK period | 50 | | | ns |
| t_{SCLK_H} | SCLK high time | 20 | | | ns |
| t_{SCLK_L} | SCLK low time | 20 | | | ns |
| t_{DSU} | Data setup time | 5 | | | ns |
| t_{DHO} | Data hold time | 5 | | | ns |
| t_{SEN_SU} | SEN falling edge to SCLK rising edge | 8 | | | ns |
| t_{SEN_HO} | Time between last SCLK rising edge to SEN rising edge | 8 | | | ns |
| t_{OUT_DV} | SDOUT delay | 12 | 20 | 28 | ns |

(1) Characterized in lab over operating temperature range, not tested at production testing.

(2) See [Figure 92](#) and [Figure 93](#).



图 1. LVDS Output Signals Timing Diagram in 16-Input Mode with 12-Bit Serialization, LSB-First, 1X Data Rate Mode

7.10 Typical Characteristics

At 25°C, AVDD_IP8 = DVDD_1P8 = 1.8 V, and DVDD_1P2 = 1.2 V, unless otherwise noted. All LVDS outputs are active with 100-Ω differential terminations and a 4-pF load capacitor from each LVDS output pin to ground. A -1-dBFS input signal at 5 MHz is applied to the input channel under test. SNR is computed by ignoring the power contained in the first nine harmonic bins, the $f_s / 2$ and $f_s / 4$ frequency bins as well as the bins corresponding to the intermodulation frequencies between the input and the clock. A LVPECL clock is used as the clock source.

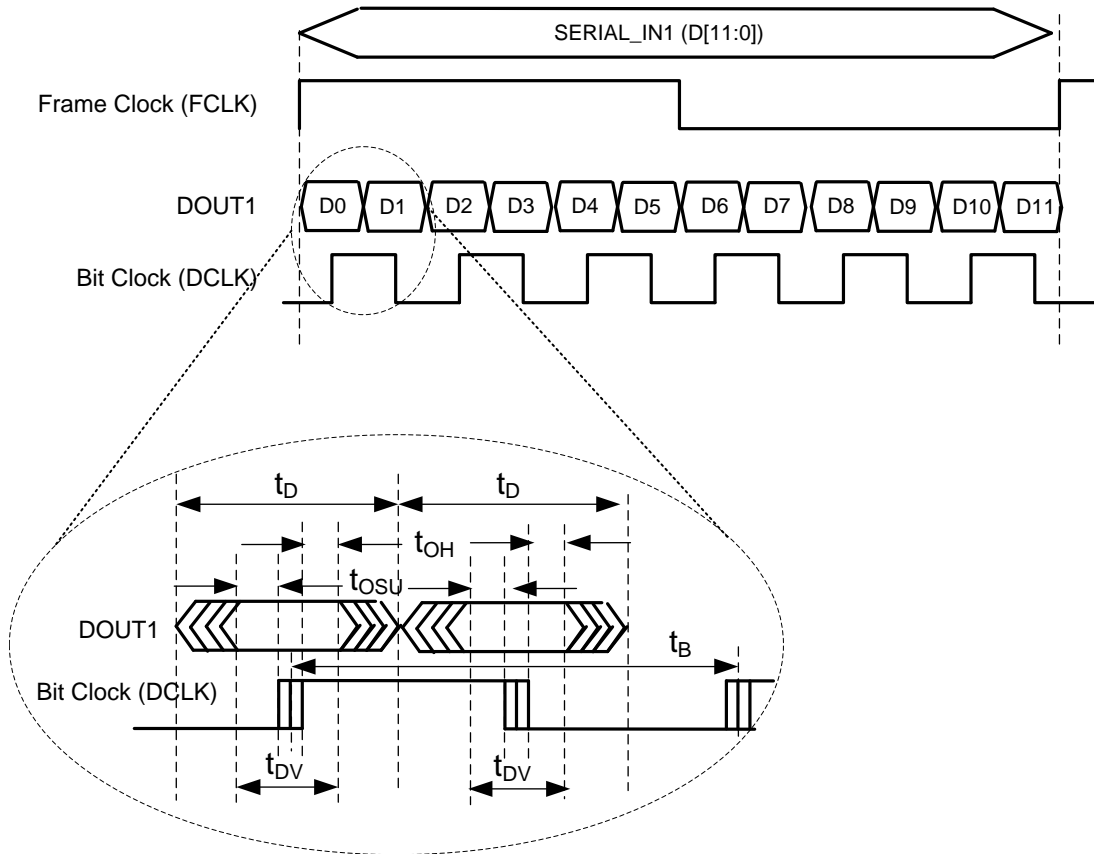
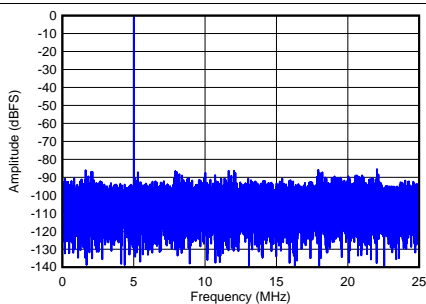

$f_{IN} = 5$ MHz, $f_C = 100$ MSPS, SNR = 61.5 dBFS, SFDR = 81.9 dBc, HD2 = -86.5 dBc, HD3 = -93.9 dBc

图 2. FFT of 10-Bit, 32-Input Mode

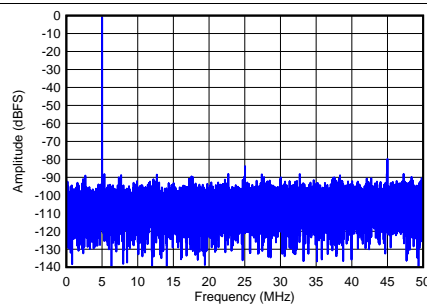

$f_{IN} = 5$ MHz, $f_C = 100$ MSPS, SNR = 61.6 dBFS, SFDR = 78.7 dBc, HD2 = -97.6 dBc, HD3 = -92.2 dBc

图 3. FFT of 10-Bit, 16-Input Mode

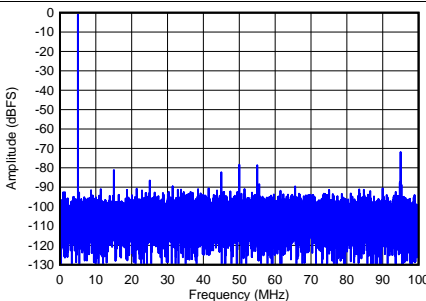

$f_{IN} = 5$ MHz, $f_C = 100$ MSPS, SNR = 61.3 dBFS, SFDR = 70.8 dBc, HD2 = -94.2 dBc, HD3 = -80.1 dBc

图 4. FFT of 10-Bit, 8-Input Mode

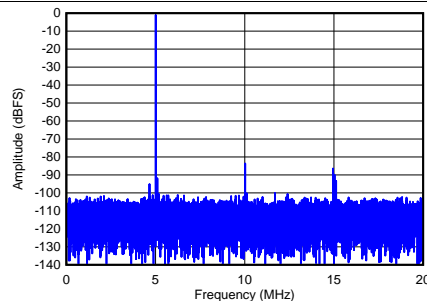

$f_{IN} = 5$ MHz, $f_C = 80$ MSPS, SNR = 69.9 dBFS, SFDR = 82.6 dBc, HD2 = -82.6 dBc, HD3 = -88.9 dBc

图 5. FFT of 12-Bit, 32-Input Mode

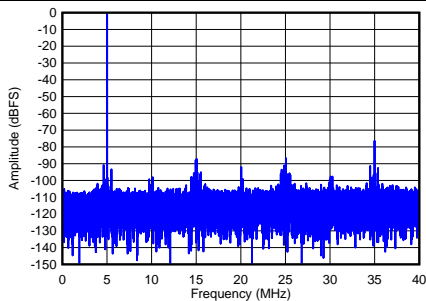

$f_{IN} = 5$ MHz, $f_C = 80$ MSPS, SNR = 70.2 dBFS, SFDR = 75.4 dBc, HD2 = -109.8 dBc, HD3 = -86.1 dBc

图 6. FFT of 12-Bit, 16-Input Mode

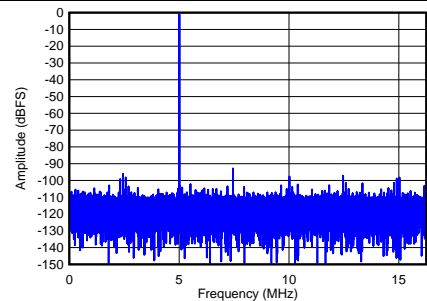

$f_{IN} = 5$ MHz, $f_C = 65$ MSPS, SNR = 73.7 dBFS, SFDR = 91.8 dBc, HD2 = -96.6 dBc, HD3 = -97.2 dBc

图 7. FFT of 14-Bit, 32-Input Mode

Typical Characteristics (接下页)

At 25°C, AVDD_IP8 = DVDD_1P8 = 1.8 V, and DVDD_1P2 = 1.2 V, unless otherwise noted. All LVDS outputs are active with 100-Ω differential terminations and a 4-pF load capacitor from each LVDS output pin to ground. A -1-dBFS input signal at 5 MHz is applied to the input channel under test. SNR is computed by ignoring the power contained in the first nine harmonic bins, the $f_s / 2$ and $f_s / 4$ frequency bins as well as the bins corresponding to the intermodulation frequencies between the input and the clock. A LVPECL clock is used as the clock source.

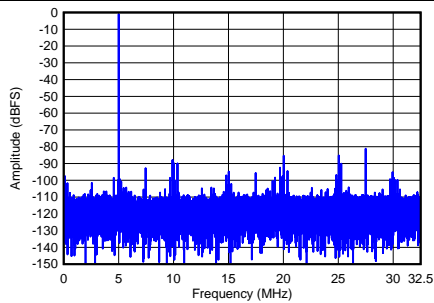

$f_{IN} = 5 \text{ MHz}$, $f_C = 65 \text{ MSPS}$, SNR = 73.4 dBFS, SFDR = 80.2 dBc, HD2 = -88.7 dBc, HD3 = -93.9 dBc

图 8. FFT of 14-Bit, 16-Input Mode

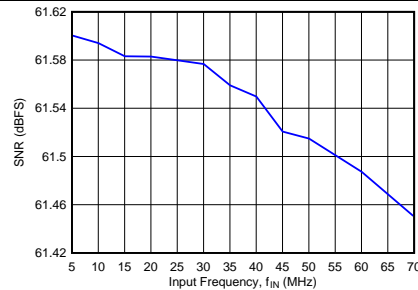

$f_{SAMP} = 50 \text{ MSPS}$

图 9. Signal-to-Noise Ratio vs f_{IN} in 10-Bit, 32-Input Mode

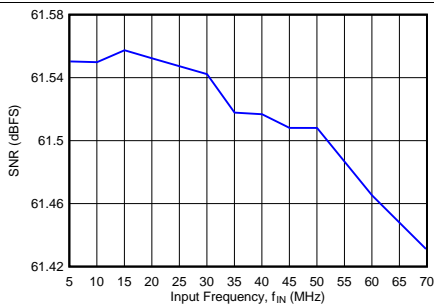

$f_{SAMP} = 100 \text{ MSPS}$

图 10. Signal-to-Noise Ratio vs f_{IN} in 10-Bit, 16-Input Mode

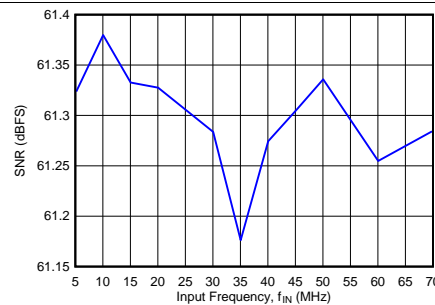

$f_{SAMP} = 200 \text{ MSPS}$

图 11. Signal-to-Noise Ratio vs f_{IN} in 10-Bit, 8-Input Mode

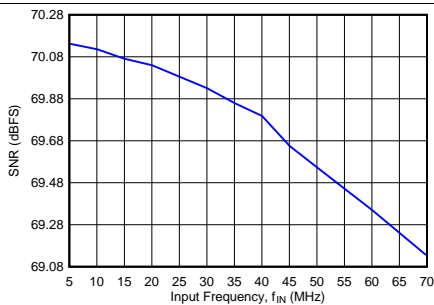

$f_{SAMP} = 40 \text{ MSPS}$

图 12. Signal-to-Noise Ratio vs f_{IN} in 12-Bit, 32-Input Mode

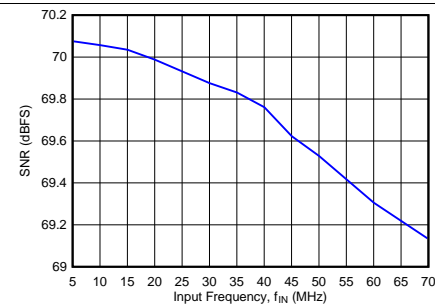

$f_{SAMP} = 80 \text{ MSPS}$

图 13. Signal-to-Noise Ratio vs f_{IN} in 12-Bit, 16-Input Mode

Typical Characteristics (接下页)

At 25°C, AVDD_IP8 = DVDD_1P8 = 1.8 V, and DVDD_1P2 = 1.2 V, unless otherwise noted. All LVDS outputs are active with 100-Ω differential terminations and a 4-pF load capacitor from each LVDS output pin to ground. A -1-dBFS input signal at 5 MHz is applied to the input channel under test. SNR is computed by ignoring the power contained in the first nine harmonic bins, the $f_s / 2$ and $f_s / 4$ frequency bins as well as the bins corresponding to the intermodulation frequencies between the input and the clock. A LVPECL clock is used as the clock source.



图 14. Signal-to-Noise Ratio vs f_{IN} in 14-Bit, 32-Input Mode



图 15. Signal-to-Noise Ratio vs f_{IN} in 14-Bit, 16-Input Mode

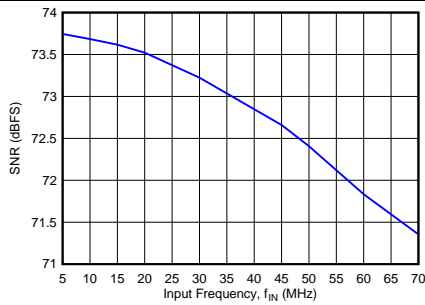

图 16. Third-Order Harmonic Distortion vs f_{IN}

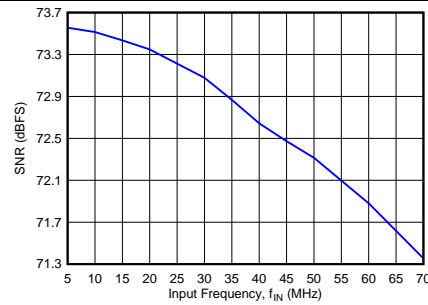

图 17. Second-Order Harmonic Distortion vs f_{IN}

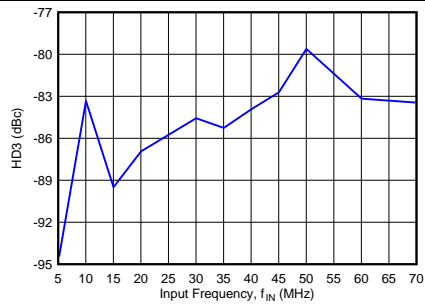

图 18. Total Harmonic Distortion vs f_{IN}

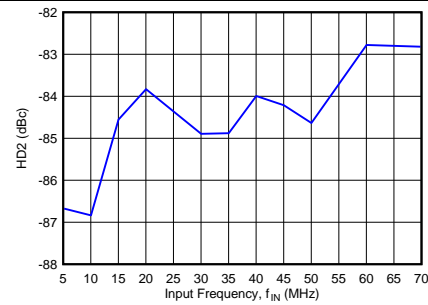

图 19. Input-Clock Intermodulation Spur at $(f_s / 2 \pm f_{IN})$ vs f_{IN} in 8-Input Mode

Typical Characteristics (接下页)

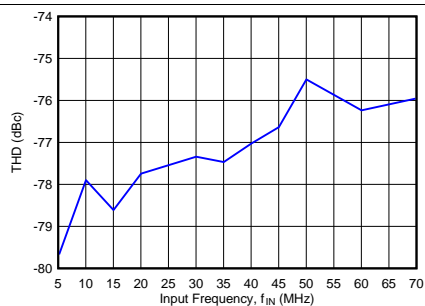
At 25°C, AVDD_IP8 = DVDD_1P8 = 1.8 V, and DVDD_1P2 = 1.2 V, unless otherwise noted. All LVDS outputs are active with 100-Ω differential terminations and a 4-pF load capacitor from each LVDS output pin to ground. A -1-dBFS input signal at 5 MHz is applied to the input channel under test. SNR is computed by ignoring the power contained in the first nine harmonic bins, the $f_s / 2$ and $f_s / 4$ frequency bins as well as the bins corresponding to the intermodulation frequencies between the input and the clock. A LVPECL clock is used as the clock source.

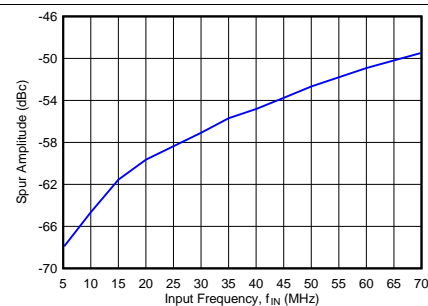

图 20. Input-Clock Intermodulation Spur at $(f_s / 2 \pm f_{IN})$ vs f_{IN} in 16-Input Mode



图 21. Input-Clock Intermodulation Spur at $(f_s / 4 \pm f_{IN})$ vs f_{IN} in 8-Input Mode

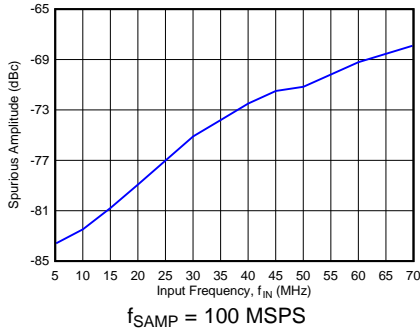

16-input mode, 14-bit resolution, $f_{SAMP} = 65$ MSPS
图 22. Signal-to-Noise Ratio vs A_{IN}

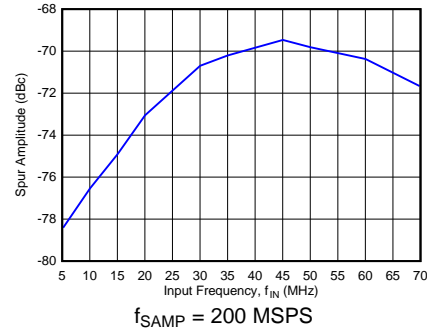
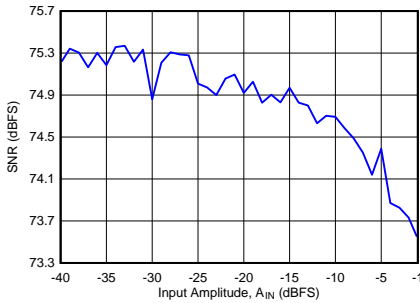
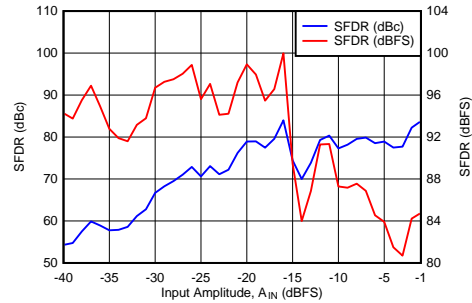

32-input mode, 14-bit resolution, $f_{SAMP} = 32.5$ MSPS
图 23. Spurious-Free Dynamic Range vs A_{IN}

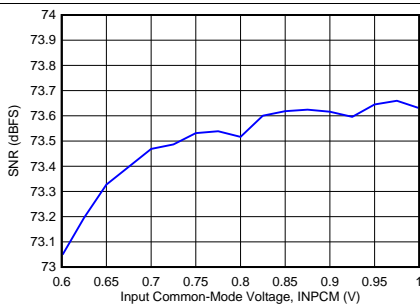

16-input mode, 14-bit resolution, $f_{SAMP} = 65$ MSPS
图 24. Signal-to-Noise Ratio vs Input Common-Mode Voltage (INPCM)

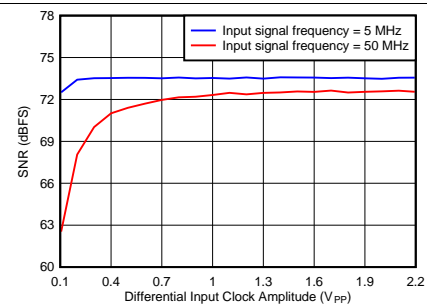

16-input mode, 14-bit resolution, $f_{SAMP} = 65$ MSPS
图 25. Signal-to-Noise Ratio vs Amplitude of Differential Sine-Wave Input Clock

Typical Characteristics (接下页)

At 25°C, AVDD_IP8 = DVDD_1P8 = 1.8 V, and DVDD_1P2 = 1.2 V, unless otherwise noted. All LVDS outputs are active with 100-Ω differential terminations and a 4-pF load capacitor from each LVDS output pin to ground. A -1-dBFS input signal at 5 MHz is applied to the input channel under test. SNR is computed by ignoring the power contained in the first nine harmonic bins, the $f_s / 2$ and $f_s / 4$ frequency bins as well as the bins corresponding to the intermodulation frequencies between the input and the clock. A LVPECL clock is used as the clock source.

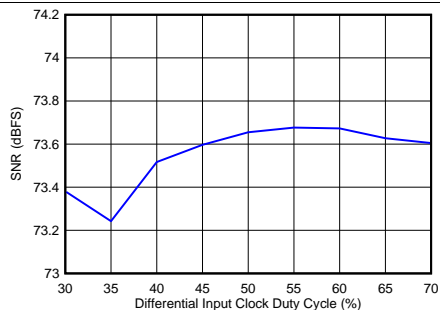

16-input mode, 14-bit resolution, $f_{SAMP} = 65$ MSPS

图 26. Signal-to-Noise Ratio vs Differential Input Clock Duty Cycle

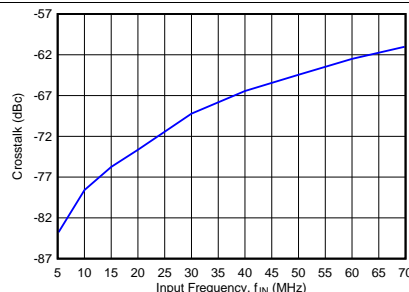

32-input mode, 14-bit resolution, $f_{SAMP} = 32.5$ MSPS, -1-dBFS tone applied on one channel and spur on neighboring channel measured as crosstalk

图 27. Crosstalk vs f_{IN}

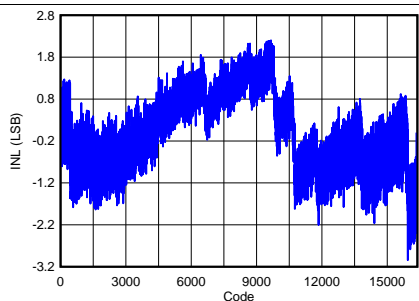

32-input mode, 14-bit resolution, $f_{SAMP} = 32.5$ MSPS

图 28. Integral Nonlinearity

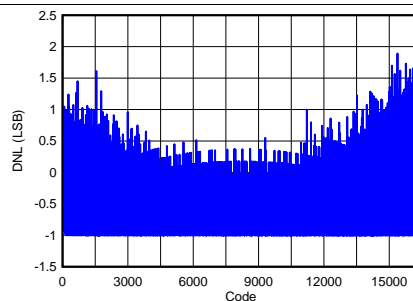

32-input mode, 14-bit resolution, $f_{SAMP} = 32.5$ MSPS

图 29. Differential Nonlinearity

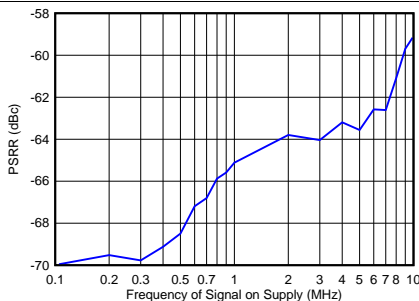

32-input mode, 14-bit resolution, $f_{SAMP} = 32.5$ MSPS, 100-mV_{PP} tone on supply

图 30. Power-Supply Rejection Ratio vs Frequency of Signal on Supply

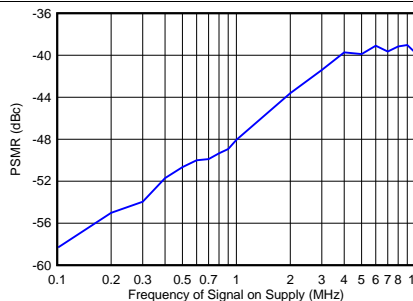

32-input mode; 14-bit resolution; $f_{SAMP} = 32.5$ MSPS; 100-mV_{PP} tone on supply; 5-MHz, -1-dBFS tone on input; PSMR is intermodulation tone referred to input tone amplitude

图 31. Power-Supply Modulation Ratio vs Frequency of Signal on Supply

Typical Characteristics (接下页)

At 25°C, AVDD_IP8 = DVDD_1P8 = 1.8 V, and DVDD_1P2 = 1.2 V, unless otherwise noted. All LVDS outputs are active with 100-Ω differential terminations and a 4-pF load capacitor from each LVDS output pin to ground. A -1-dBFS input signal at 5 MHz is applied to the input channel under test. SNR is computed by ignoring the power contained in the first nine harmonic bins, the $f_s / 2$ and $f_s / 4$ frequency bins as well as the bins corresponding to the intermodulation frequencies between the input and the clock. A LVPECL clock is used as the clock source.

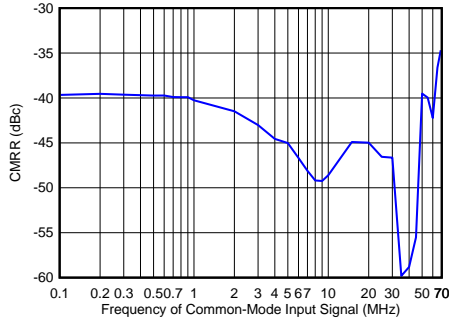

32-input mode, 14-bit resolution, $f_{SAMP} = 32.5$ MSPS, 50-mV_{PP} common-mode tone applied at the inputs, output tone referred to the input tone

图 32. Common-Mode Rejection Ratio vs Frequency of Common-Mode Input Signal

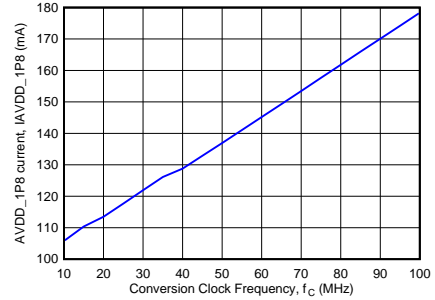

32-input mode, 10-bit resolution

图 33. AVDD_1P8 Current vs Conversion Clock Frequency

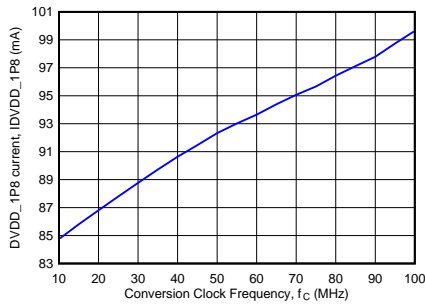

32-input mode, 10-bit resolution

图 34. DVDD_1P8 Current vs Conversion Clock Frequency

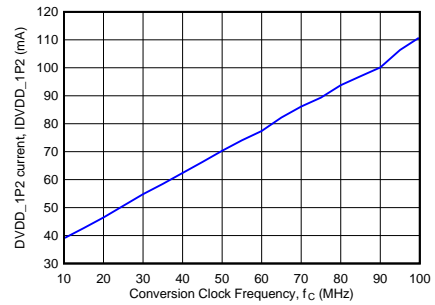

32-input mode, 10-bit resolution

图 35. DVDD_1P2 Current vs Conversion Clock Frequency

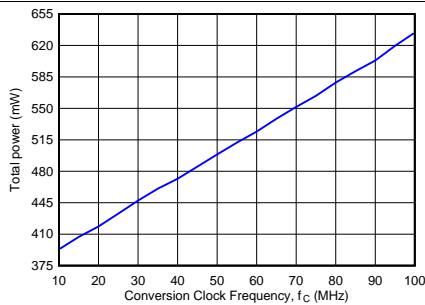

32-input mode, 10-bit resolution

图 36. Total Power vs Conversion Clock Frequency



图 37. Digital High-Pass Filter Response

Typical Characteristics (接下页)

At 25°C, AVDD_IP8 = DVDD_1P8 = 1.8 V, and DVDD_1P2 = 1.2 V, unless otherwise noted. All LVDS outputs are active with 100-Ω differential terminations and a 4-pF load capacitor from each LVDS output pin to ground. A -1-dBFS input signal at 5 MHz is applied to the input channel under test. SNR is computed by ignoring the power contained in the first nine harmonic bins, the $f_s / 2$ and $f_s / 4$ frequency bins as well as the bins corresponding to the intermodulation frequencies between the input and the clock. A LVPECL clock is used as the clock source.

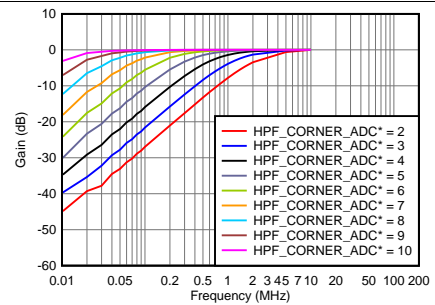
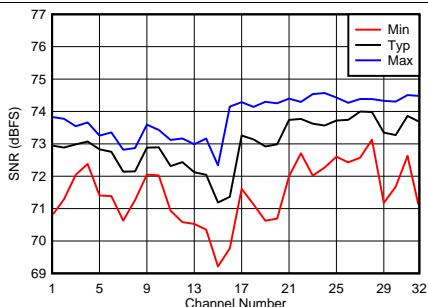

Statistical values taken over 100 devices in 14-bit, 32-input mode at $f_{SAMP} = 32.5$ MSPS

图 38. Signal-to-Noise Ratio Histogram

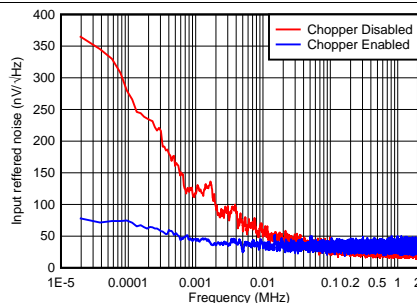

16-input mode, 12-bit resolution

图 39. Low-Frequency Noise With and Without Chopper Enabled

7.11 Typical Characteristics: JESD Interface

Typical values are at $T_A = 25^\circ\text{C}$, $AVDD_{1P8} = 1.8\text{ V}$, $DVDD_{1P2} = 1.2\text{ V}$, $DVDD_{1P8} = 1.8\text{ V}$, differential ADC clock, $R_{LOAD} = 50\ \Omega$ from each CML pin to $DVDD_{1P2}$, 12-bit ADC resolution, sample rate, and $f_{CLKIN} = 80\text{ MSPS}$, unless otherwise noted. Minimum and maximum values are across the full temperature range of $T_{MIN} = -40^\circ\text{C}$ to $T_{MAX} = 85^\circ\text{C}$. The JESD204B interface operates in default mode after setting the JESD_EN bit to 1 (12-bit ADC resolution, 12-bit serialization, 4 ADCs per lane, and scrambling disabled).

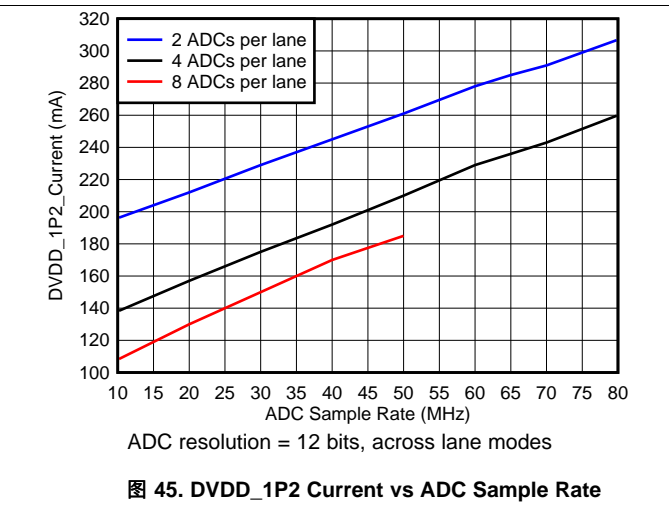
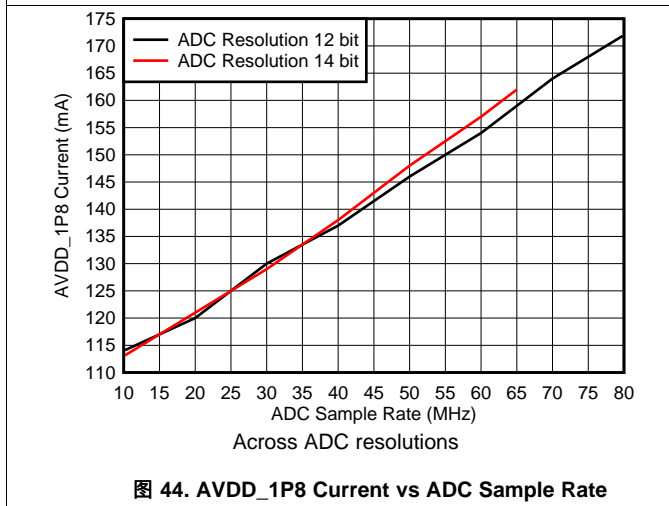
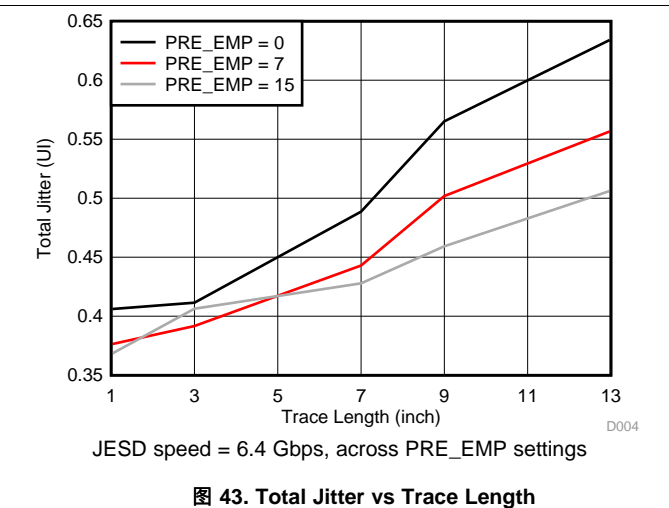
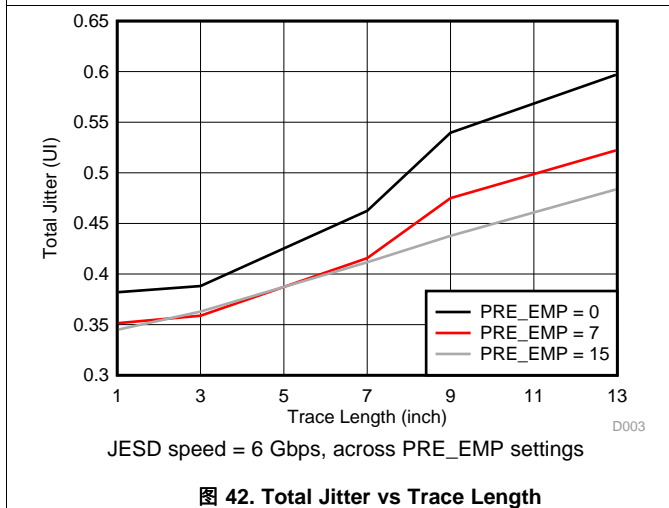
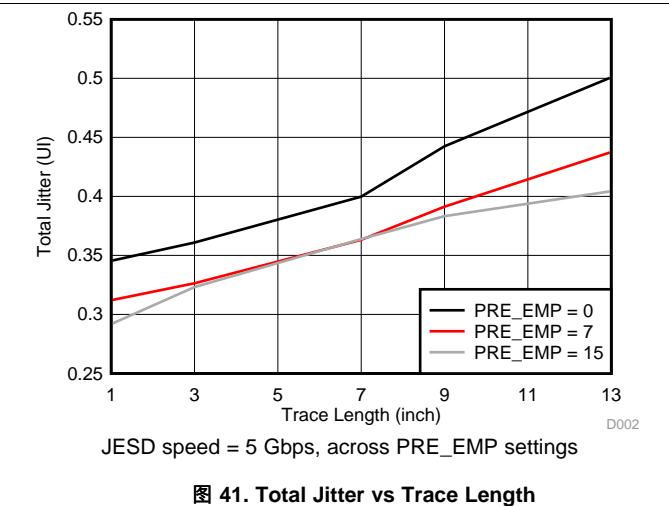
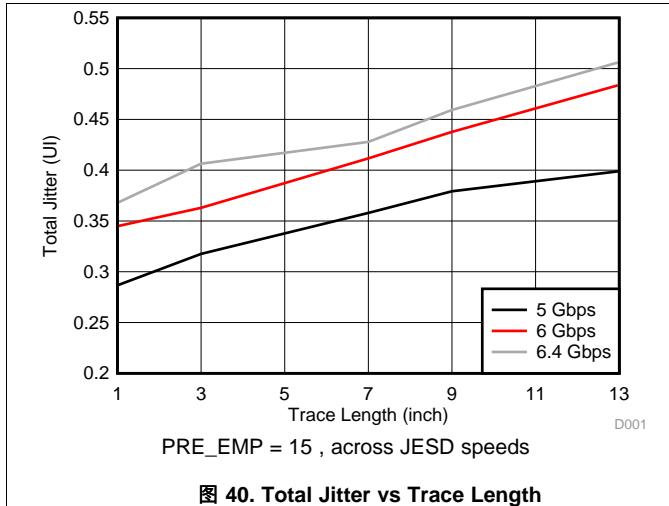

Typical Characteristics: JESD Interface (接下页)

Typical values are at $T_A = 25^\circ\text{C}$, $AVDD_1P8 = 1.8\text{ V}$, $DVDD_1P2 = 1.2\text{ V}$, $DVDD_1P8 = 1.8\text{ V}$, differential ADC clock, $R_{LOAD} = 50\ \Omega$ from each CML pin to $DVDD_1P2$, 12-bit ADC resolution, sample rate, and $f_{CLKIN} = 80\text{ MSPS}$, unless otherwise noted. Minimum and maximum values are across the full temperature range of $T_{MIN} = -40^\circ\text{C}$ to $T_{MAX} = 85^\circ\text{C}$. The JESD204B interface operates in default mode after setting the JESD_EN bit to 1 (12-bit ADC resolution, 12-bit serialization, 4 ADCs per lane, and scrambling disabled).

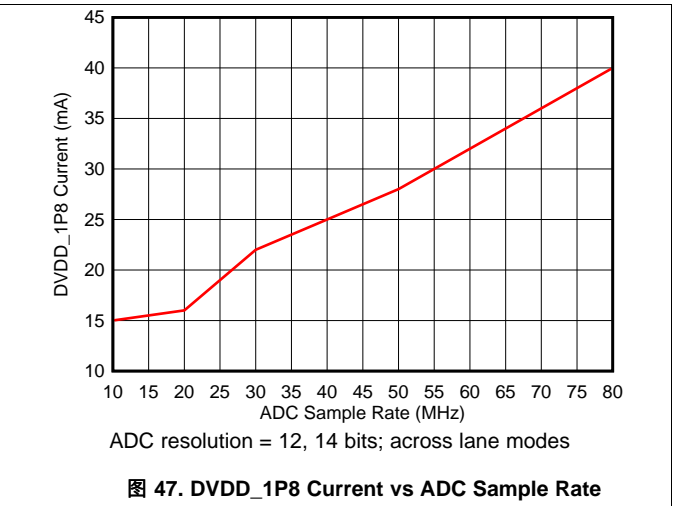
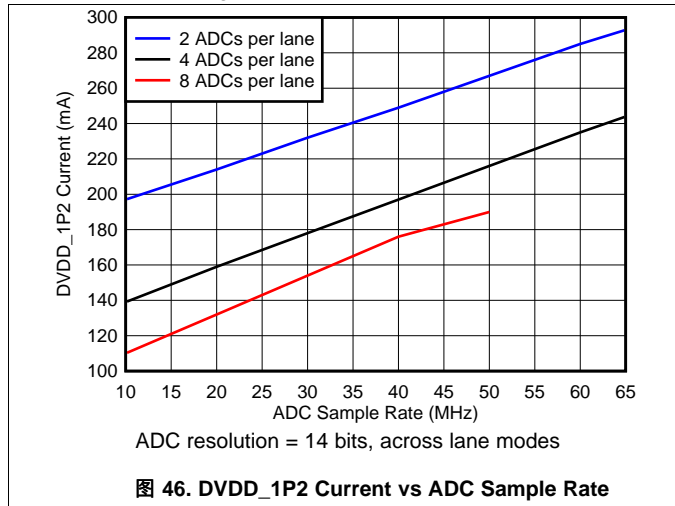

7.12 Typical Characteristics: Contour Plots

At 25°C, AVDD_IP8 = DVDD_1P8 = 1.8 V, and DVDD_1P2 = 1.2 V, unless otherwise noted. All LVDS outputs are active with 100-Ω differential terminations and a 4-pF load capacitor from each LVDS output pin to ground. A -1-dBFS input signal at 5 MHz is applied to the input channel under test. SNR is computed by ignoring the power contained in the first nine harmonic bins, the $f_s / 2$ and $f_s / 4$ frequency bins as well as the bins corresponding to the intermodulation frequencies between the input and the clock. An LVPECL clock is used as the clock source.



图 48. Signal-to-Noise Ratio in 10-Bit, 32-Input Mode



图 49. Signal-to-Noise Ratio in 10-Bit, 16-Input Mode

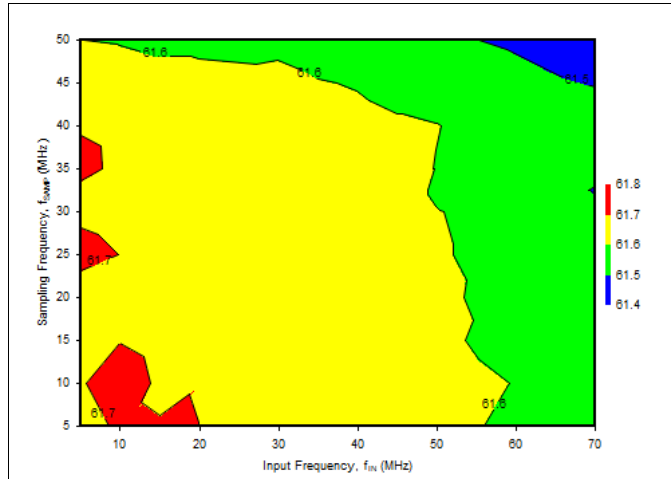

图 50. Signal-to-Noise Ratio in 10-Bit, 8-Input Mode

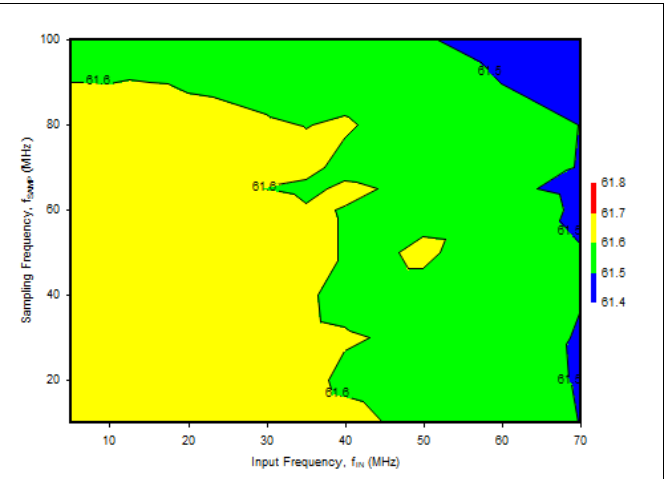

图 51. Signal-to-Noise Ratio in 12-Bit, 32-Input Mode

Typical Characteristics: Contour Plots (接下页)

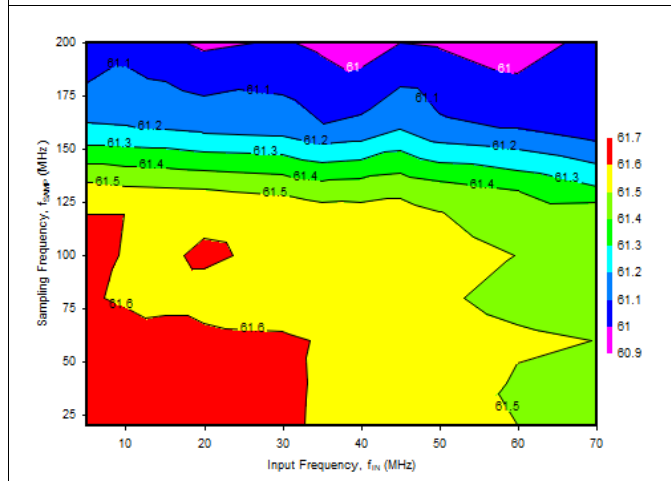
At 25°C, AVDD_IP8 = DVDD_1P8 = 1.8 V, and DVDD_1P2 = 1.2 V, unless otherwise noted. All LVDS outputs are active with 100-Ω differential terminations and a 4-pF load capacitor from each LVDS output pin to ground. A -1-dBFS input signal at 5 MHz is applied to the input channel under test. SNR is computed by ignoring the power contained in the first nine harmonic bins, the $f_s / 2$ and $f_s / 4$ frequency bins as well as the bins corresponding to the intermodulation frequencies between the input and the clock. An LVPECL clock is used as the clock source.

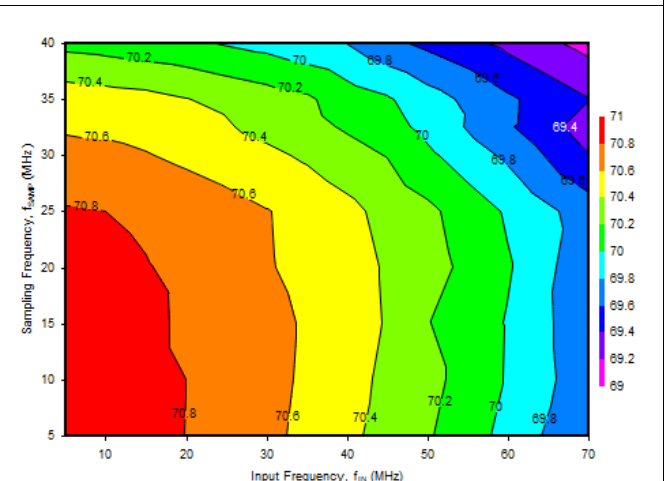

图 52. Signal-to-Noise Ratio in 12-Bit, 16-Input Mode



图 53. Signal-to-Noise Ratio in 14-Bit, 32-Input Mode

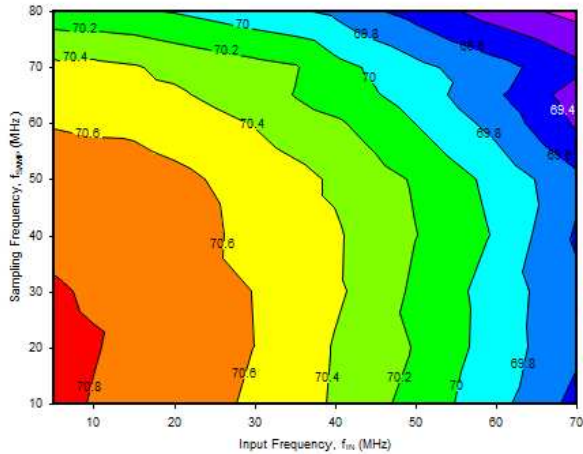

图 54. Signal-to-Noise Ratio in 14-Bit, 16-Input Mode

8 Detailed Description

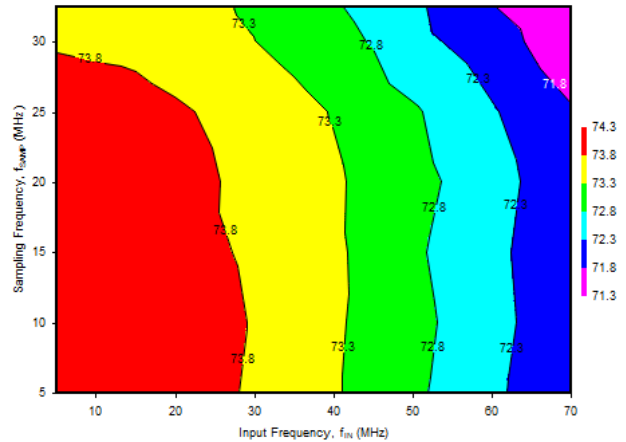
8.1 Overview

A block diagram of the device is shown in 图 55. 图 56 illustrates the signal flow for the device while operating with the LVDS output interface. The device consists of 16 ADCs configurable to convert 8-, 16-, or 32-inputs. All ADCs run off the external clocks (provided on the CLKP, CLKM pins). The references needed for the ADCs are internally generated. The reference voltage that can be used to set the common mode voltage of the analog input comes out on the VCM pin. The output data from the 16 ADCs are serialized and output on the LVDS interface. The device also has an optional JESD204B interface. The device is controlled using an SPI interface.

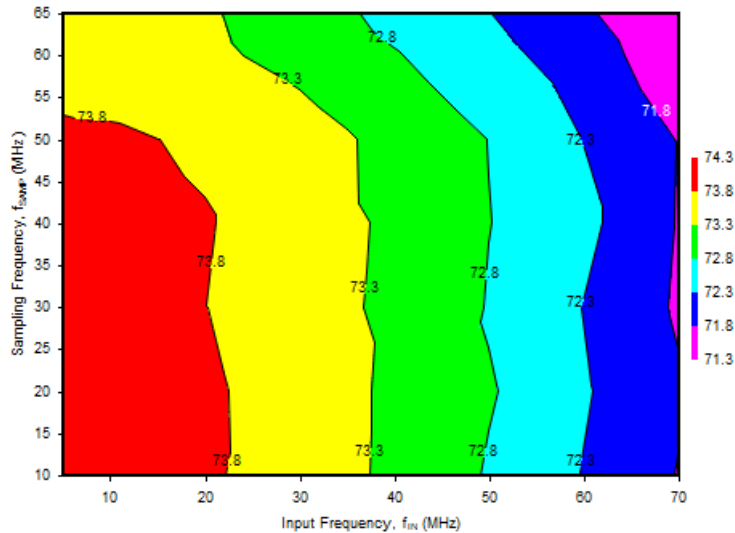
8.2 Functional Block Diagrams



图 55. Block Diagram

Functional Block Diagrams (接下页)

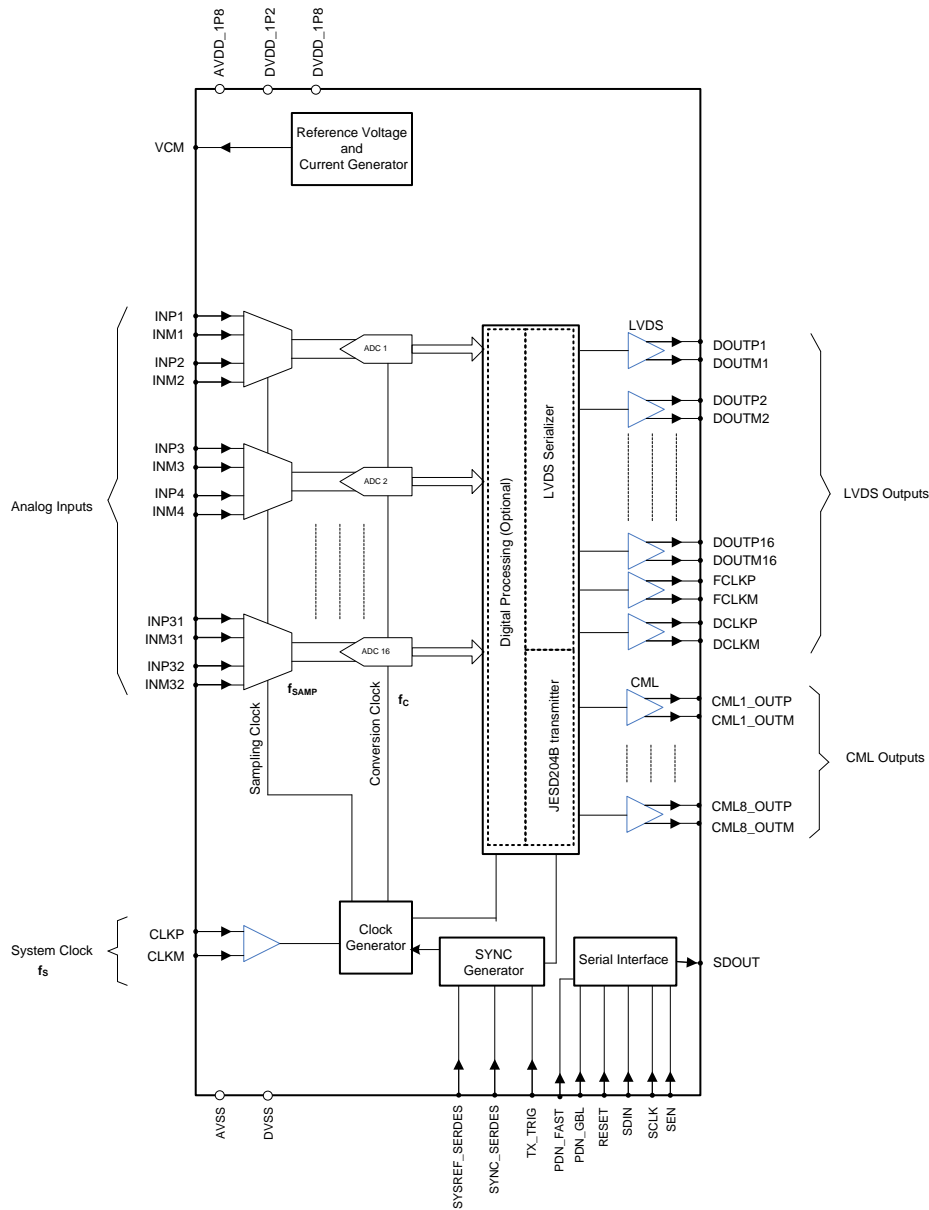

图 56. Signal Flow Diagram

8.3 Feature Description

The device has 16 synchronously operating ADCs (ADC1 to ADC16) and can be configured to accept and convert 8, 16, or 32 active differential external analog inputs (AIN1 to AIN32). The converted digital outputs can be made to come out on either 16 pairs of low-voltage differential signaling (LVDS) outputs or compressed into eight pairs. The device operates from a single clock input. This input is referred to as the system clock and its frequency is denoted by f_s . The recommended mode of driving the clock is with a differential low-voltage positive-referenced emitter coupled logic (LVPECL) clock. The system clock can be also driven by a differential sine-wave or LVDS, or can be driven with a single-ended low voltage complementary metal oxide semiconductor (LVCMOS) clock. The various aspects of the signal chain are discussed in the following sections.

Feature Description (接下页)

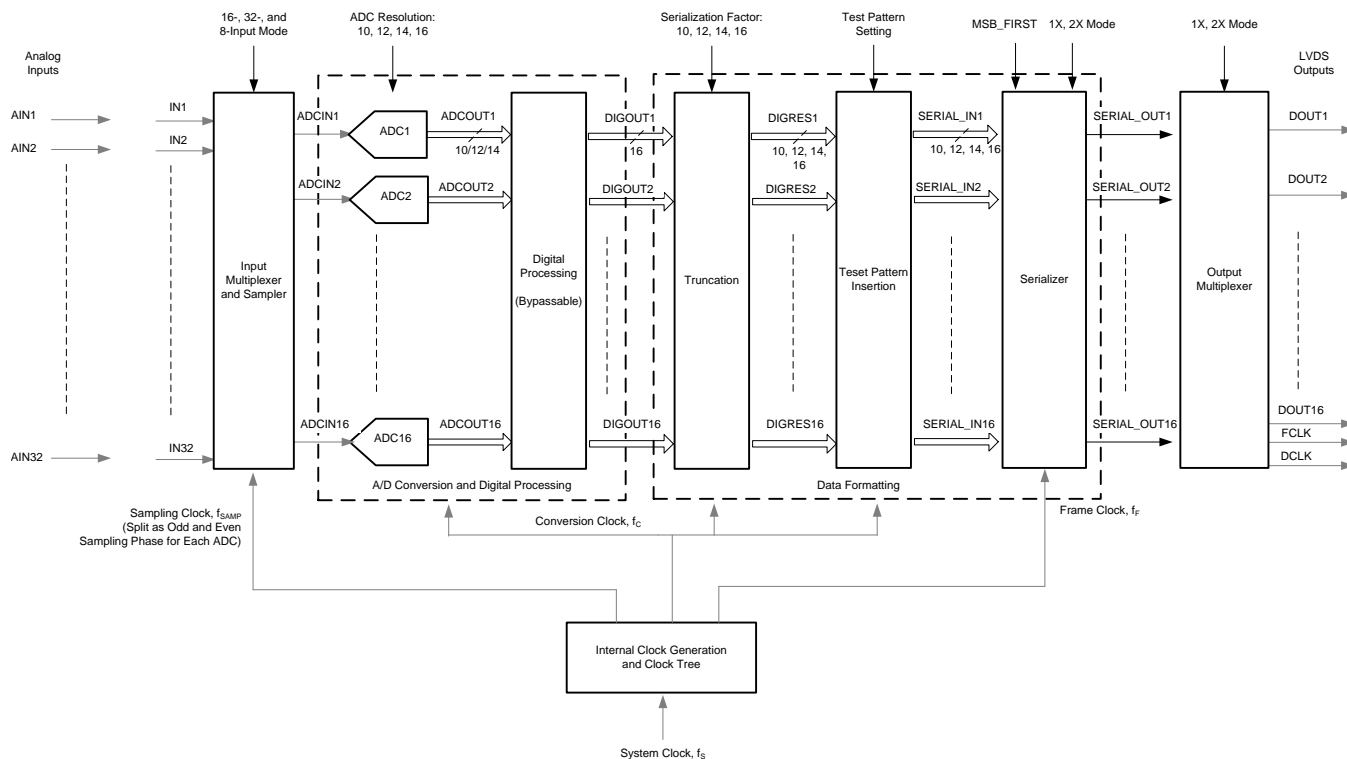
8.3.1 Connection of the External Inputs to the Input Pins

The effective conversion rate per input changes depending on the input mode. The methodology of connecting the external inputs (AINx) to the input pins (INx) is shown in 表 1 for the 16-, 32- and 8-channel input modes. In 表 1, AIN1 refers to the differential input signal (AINP1, AINM1) and IN1 refers to the input pair (INP1, INM1). The voltage that gets sampled and converted by the device is (AINP1-AINM1).

表 1. Scheme of Driving the Input Pins (16-, 32-, 8-Channel Input Modes)

| INPUT PAIR | CONNECTION TO THE EXTERNAL ANALOG INPUT SIGNAL | | |
|------------|--|-----------------------|-------------------------------------|
| | 16-CHANNEL INPUT MODE ⁽¹⁾⁽²⁾ | 32-CHANNEL INPUT MODE | 8-CHANNEL INPUT MODE ⁽¹⁾ |
| IN1 | AIN1 | AIN1 | AIN1 |
| IN2 | — | AIN2 | — |
| IN3 | AIN2 | AIN3 | AIN1 |
| IN4 | — | AIN4 | — |
| IN5 | AIN3 | AIN5 | AIN2 |
| IN6 | — | AIN6 | — |
| IN7 | AIN4 | AIN7 | AIN2 |
| IN8 | — | AIN8 | — |
| IN9 | AIN5 | AIN9 | AIN3 |
| IN10 | — | AIN10 | — |
| IN11 | AIN6 | AIN11 | AIN3 |
| IN12 | — | AIN12 | — |
| IN13 | AIN7 | AIN13 | AIN4 |
| IN14 | — | AIN14 | — |
| IN15 | AIN8 | AIN15 | AIN4 |
| IN16 | — | AIN16 | — |
| IN17 | AIN9 | AIN17 | AIN5 |
| IN18 | — | AIN18 | — |
| IN19 | AIN10 | AIN19 | AIN5 |
| IN20 | — | AIN20 | — |
| IN21 | AIN11 | AIN21 | AIN6 |
| IN22 | — | AIN22 | — |
| IN23 | AIN12 | AIN23 | AIN6 |
| IN24 | — | AIN24 | — |
| IN25 | AIN13 | AIN25 | AIN7 |
| IN26 | — | AIN26 | — |
| IN27 | AIN14 | AIN27 | AIN7 |
| IN28 | — | AIN28 | — |
| IN29 | AIN15 | AIN29 | AIN8 |
| IN30 | — | AIN30 | — |
| IN31 | AIN16 | AIN31 | AIN8 |
| IN32 | — | AIN32 | — |

(1) — = do not connect.

(2) To switch ADCx to convert the even numbered inputs, use register control IN_16CH_ADCx.

8.3.2 Input Multiplexer and Sampler

The input multiplexer determines the mapping of the input pins (IN1 to IN32) to the inputs that are sampled and converted by the ADCs (ADC1 to ADC16). Each ADC has two sets of sampling circuits (termed odd and even) and alternately converts the inputs presented to them.

The sampling windows for the odd and even sampling circuits of each ADC are derived from the system clock. A pair of ADCs are used in [图 57](#), [图 58](#), and [图 59](#) to illustrate how the odd and even sampling phases are derived for each ADC in each input mode. AIN1 (t_1) refers to the AIN1 input sampled at the t_1 instant. ADC1o refers to the odd sample converted by ADC1 and ADC1e refers to the even sample converted by ADC1. The input sampling and conversion schemes for the 32-, 16-, and 8-input modes are illustrated in [图 57](#), [图 58](#), and [图 59](#), respectively.



图 57. Input Sampling and Conversion Scheme (32-Input Mode)



图 58. Input Sampling and Conversion Scheme (16-Input Mode)

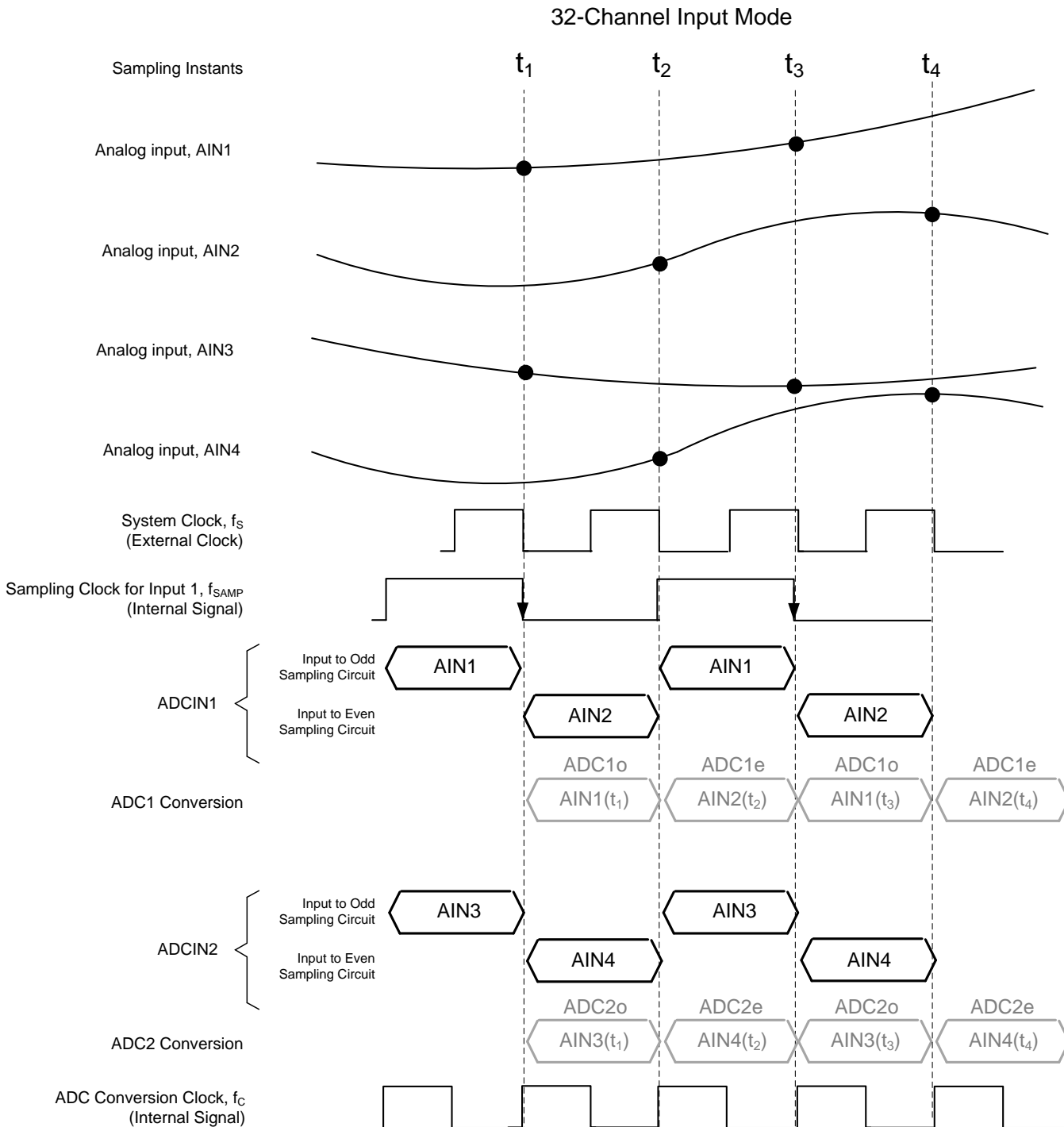

图 59. Input Sampling and Conversion Scheme (8-Input Mode)

Mapping the inputs of the odd and even sampling circuits of subsequent-numbered ADCs to subsequent-numbered sets of input pairs repeats in a similar manner.

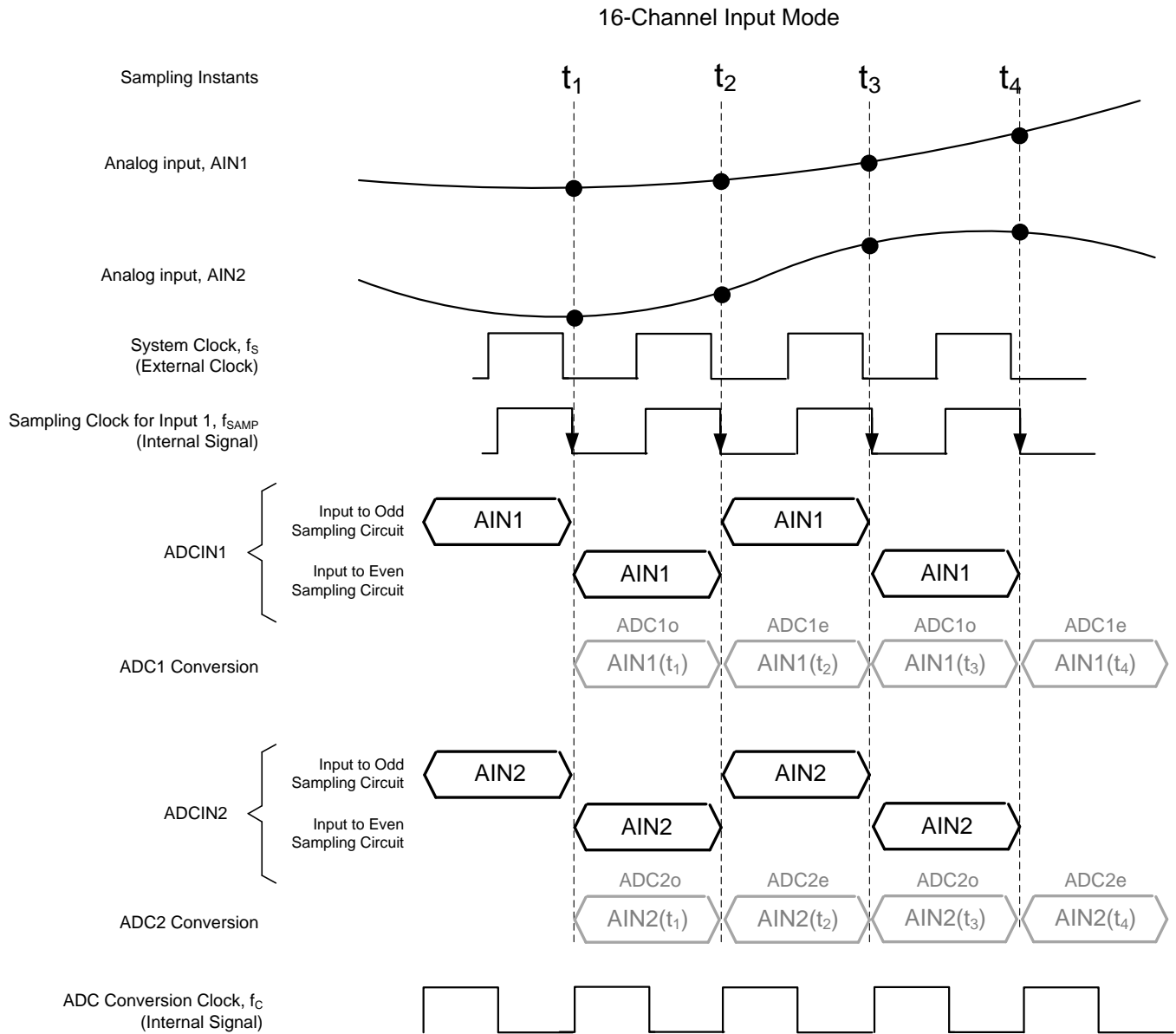
The sampling rate (f_{SAMP}) can be defined as the rate at which the device converts each analog input presented to it. The relationship between the sampling rate and the system clock frequency is listed in 表 2 for the three input modes.

表 2. Sampling Rate and Input Clock Frequency

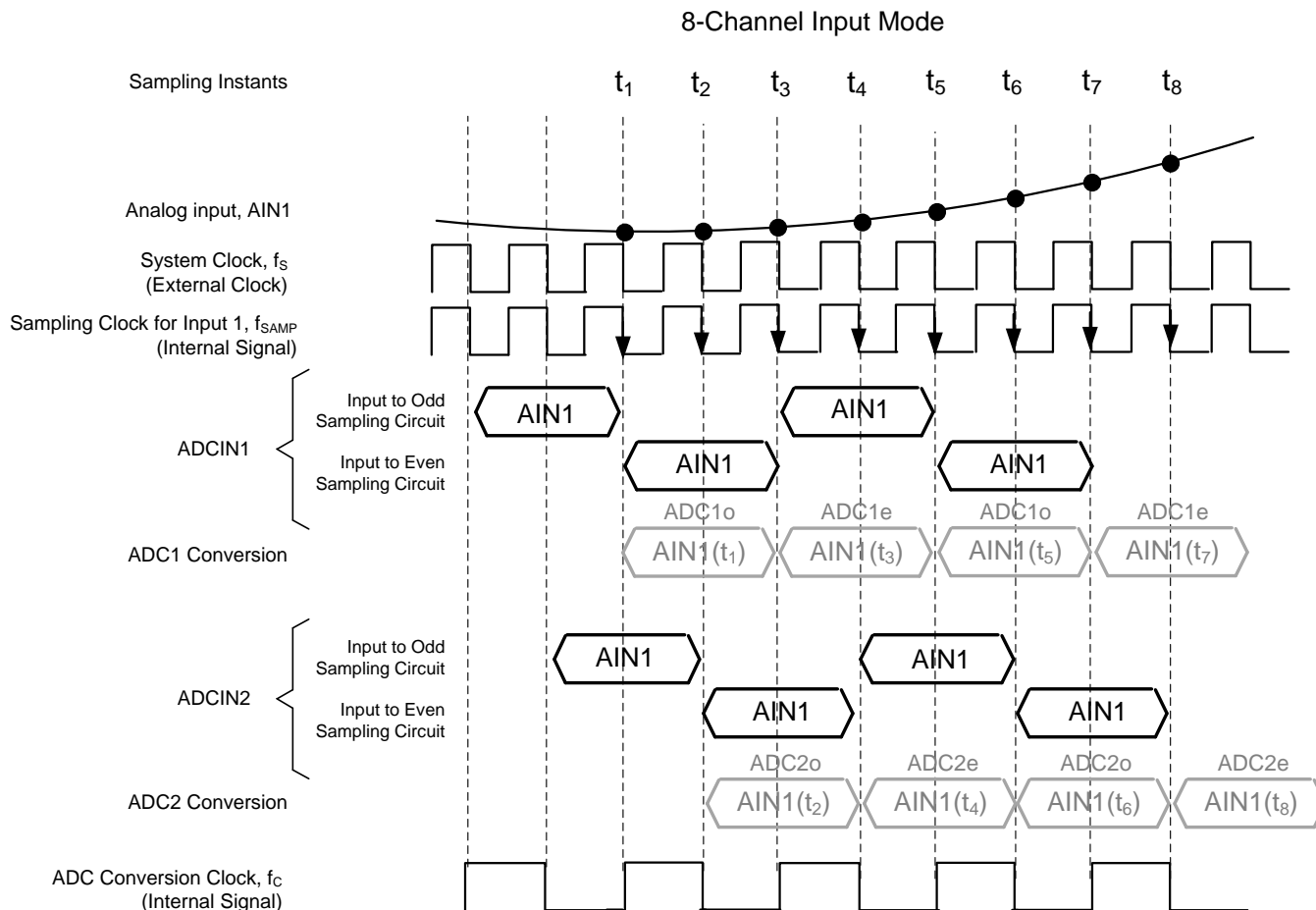
| ANALOG INPUT MODE (Number of Input Channels) | SAMPLING RATE (f _{SAMP}) |
|--|------------------------------------|
| 16 | f _s |
| 32 | 0.5 × f _s |
| 8 | f _s |

In 16-input mode, each ADC converts one input at a sampling rate equal to the system clock. In 32-input mode, one ADC alternately converts two sets of inputs, each at a sampling rate that is half the system clock. In the 8-input mode, two ADCs convert the same input in interleaved manner.

In 16-input mode, a ping-pong operation exists between two sampling circuits of one ADC that are sampling the same input. The mismatch between the two sampling circuit bandwidths can result in an interleaving spur at (f_s / 2 ± f_{IN}), where f_s is the frequency of the system clock and f_{IN} is the frequency of the input signal.

In 8-input mode, additional interleaving across two adjacent ADCs is present in addition to the ping-pong operation between the two sampling circuits of the same ADC. This increased mismatch can result in significant interleaving spurs at (f_s / 2 ± f_{IN}) and (f_s / 4 ± f_{IN}). The offset mismatch between the four sets of sampling circuits can result in a spur at f_s / 4.

For the 32-input mode, the sampling instants of the even-numbered input signals are offset from the sampling instants of the odd-numbered input signals by one system clock period. The magnitude of the interleaving spurs increases when the input frequency is increased because the sampling bandwidth mismatch across the different sampling circuits results in larger phase error mismatches when the input frequency is increased.

8.3.3 Analog-to-Digital Converter (ADC)

The device has 16 synchronous ADCs that provide a digital representation of the input in twos complement format. Each ADC converts at a rate of f_C using a conversion clock that is internally generated from the system clock. Every cycle of a conversion clock corresponds to a new ADC conversion.

The mapping of the ADC conversions to the analog input is described in 表 3. See 图 57, 图 58, and 图 59 for the naming conventions.

表 3. Mapping of the ADC Conversions to the Analog Inputs and Sampling Instants

| ADC SAMPLE | INPUT CONVERTED BY THE ADC | | |
|------------|----------------------------|----------------|----------------|
| | 16-INPUT MODE | 32-INPUT MODE | 8-INPUT MODE |
| ADC1o | AIN1 (t_1) | AIN1 (t_1) | AIN1 (t_1) |
| ADC2o | AIN2 (t_1) | AIN3 (t_1) | AIN1 (t_2) |
| ADC1e | AIN1 (t_2) | AIN2 (t_2) | AIN1 (t_3) |
| ADC2e | AIN2 (t_2) | AIN4 (t_2) | AIN1 (t_4) |

The ADC resolution (the number of bits in the signals marked as ADCOUT1 to ADCOUT16) can be programmed as 10, 12, or 14 bits using the ADC_RES bits. The maximum conversion clock of the ADC depends on the ADC resolution setting, as shown in 表 4.

表 4. Maximum Conversion Rate of the ADC for Different ADC Resolutions

| ADC RESOLUTION (Bits) | MAXIMUM CONVERSION CLOCK ($f_{C(max)}$, MSPS) |
|-----------------------|---|
| 10 | 100 |
| 12 | 80 |
| 14 | 65 |

The relationship between the system clock and sampling clock rates to the ADC conversion clock is shown in 表 5. Note that the maximum conversion rate of the ADC is fixed for the three resolution modes. In 表 5, *sampling rate* refers to the effective rate of sampling each active analog input.

表 5. System Clock and Sampling Clock Relationship to the ADC Conversion Clock

| ANALOG INPUT MODE (Number of Input Channels) | SYSTEM CLOCK RATE (f_S) | SAMPLING RATE (f_{SAMP}) ⁽¹⁾ | ADC RESOLUTIONS SUPPORTED |
|---|-----------------------------|---|---------------------------|
| 16 | f_C | f_C | 10, 12, 14 |
| 32 | f_C | $0.5 \times f_C$ | 10, 12, 14 |
| 8 | $2 \times f_C$ | $2 \times f_C$ | 10 |

(1) Sampling rate is also the effective conversion rate of each input channel.

8.3.4 Device Synchronization Using TX_TRIG

The device has multiple PLLs and clock dividers that are used to generate the programmable ADC resolutions and LVDS synchronization factors as well as to synchronize LVDS test patterns.

The TX_TRIG input is used to synchronize clock dividers inside the device. The synchronization achieved using TX_TRIG also enables multiple parallel devices to operate synchronously.

For the 32-input mode, the same ADC alternates between converting two inputs. The TX_TRIG signal provides the mechanism to determine the sampling instants of the odd and even input signals with respect to the system clock, as shown in 图 60.



图 60. Odd- and Even-Channel Sampling Instant Definition Mechanism in 32-Input Mode with the TX_TRIG Signal

For the 8-input mode, the conversion clock is obtained by dividing the system clock by 2. The phase of the division is again determined by the TX_TRIG signal, as shown in 图 61.

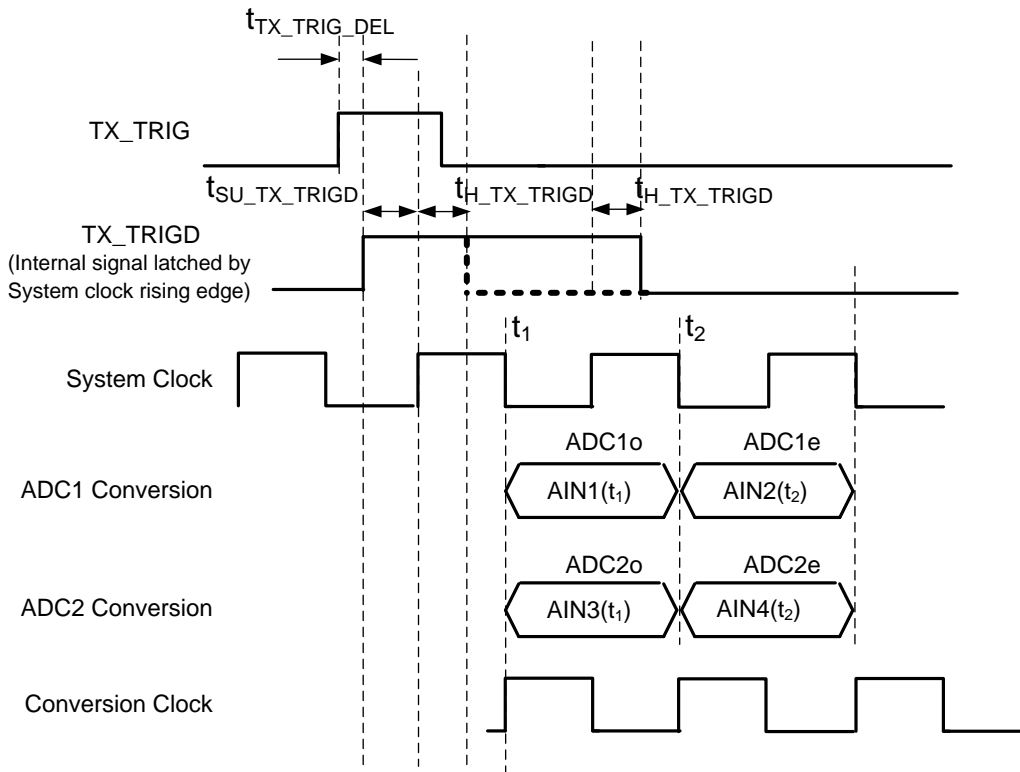

图 61. Conversion Clock Deriving Mechanism from Division of the Sampling Clock in 8-Input Mode

Applying a pulse on TX_TRIG is a mandatory part of the power-up and initialization sequence; see the [Power Sequencing and Initialization](#) section.

In case a TX_TRIG is not applied, the device can possibly behave in an unexpected manner. The identified cases are shown in 表 6.

表 6. Device Behavior Cases: TX_TRIG is Not Applied

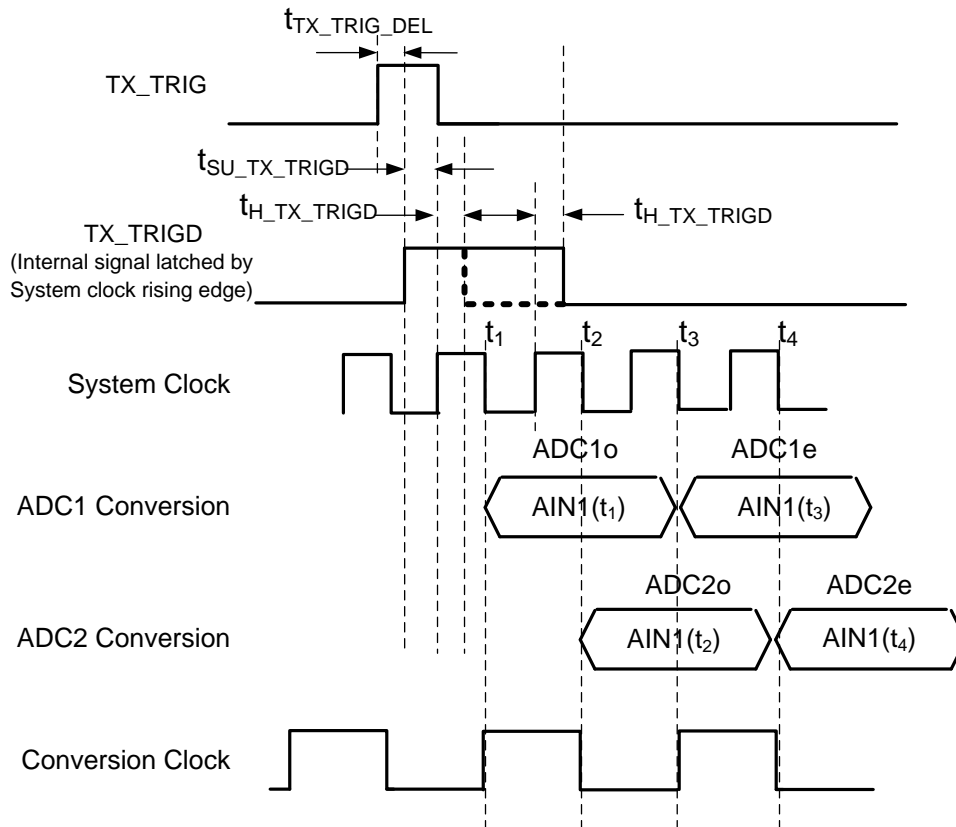
| SCENARIO | ISSUE | INPUT MODE WHERE ISSUE OCCURS (8-, 16-, 32-Channel Input Modes) |
|--|---|---|
| Multiple devices operating in parallel | Frame clock across devices is not synchronized | 8- and 32-channel input modes |
| | LVDS patterns across devices are not synchronized | 8-, 16-, and 32-channel input modes |
| Serialization factor different from ADC resolution | Framing of data words within a frame clock is not defined | 8- and 32-channel input modes |

The TX_TRIG pulse resets the phase of the test pattern generator, the odd and even sampling phase selection, and the phase of the frame clock. As a result of this phase reset operation, the ADC data can be corrupted for four to six clocks immediately after applying TX_TRIG. The phase reset from TX_TRIG can be disabled using MASK_TX_TRIG.

8.3.5 Digital Processing

The ADC outputs go to a digital processing block that can be used to enhance ADC performance. Some of the operations done in the digital processing block can enhance the effective signal to noise ratio at its output. For this reason, the number of bits at the DIGOUT1 to DIGOUT16 signals are considered to be 16. However, some of the LSBs of this 16-bit word may be zero. For example, when the digital processing block is bypassed, the number of non-zero bits in DIGOUT is the same as the ADC resolution—the extra LSBs of the 16-bit word are zero.

The digital processing block results in additional latency that can be avoided by using the low latency mode (programmed using the LOW_LATENCY_EN bit) that bypasses the entire digital processing block without introducing extra latency. The various features available in the digital processing block are shown in 图 62 and are explained in the subsequent sections.



图 62. ADC Digital Block Diagram

8.3.5.1 Digital Offset

Digital functionality provides for channel offset correction. Setting the DIG_OFFSET_EN bit to 1 enables the subtraction of the offset value from the ADC output. There are two offset correction modes, as shown in 图 63.

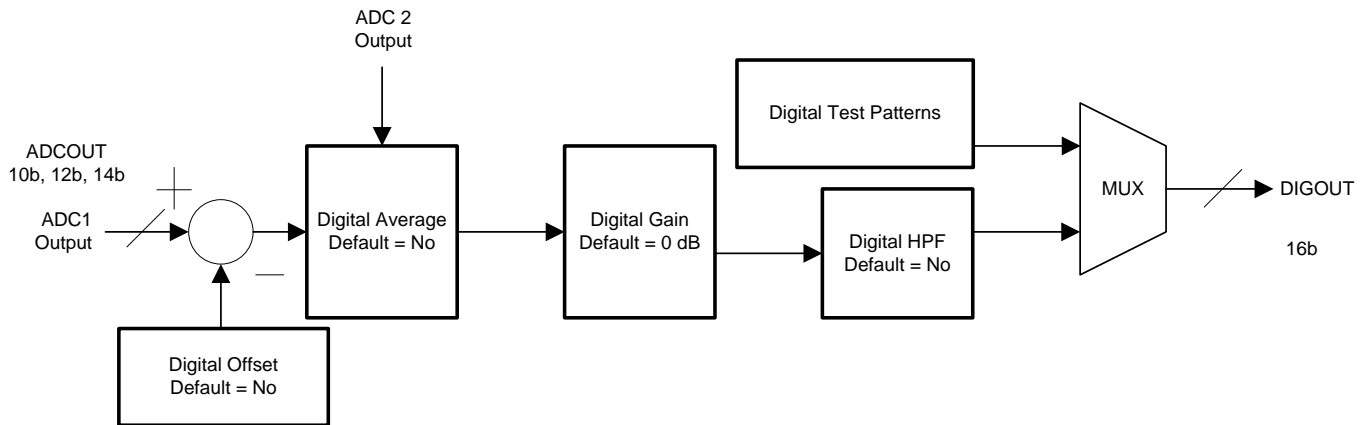

图 63. Digital Offset Correction Block Diagram

8.3.5.1.1 Manual Offset Correction

If the channel offset is known or estimated, it can be written into a 10-bit register and can be subtracted from the ADC output. There are 32 sets of manual offset controls. To enable per-channel offset correction in the 32-input mode, the offset values for the odd and even data streams of each of the 16 ADCs can be independently controlled. The registers OFFSET_ADCxo and OFFSET_ADCxe correspond to the offsets subtracted from the odd and even data streams of ADCx. Write the offset values in twos complement format.

8.3.5.1.2 Auto Offset Correction Mode (Offset Correction using a Built-In Offset Calculation Function)

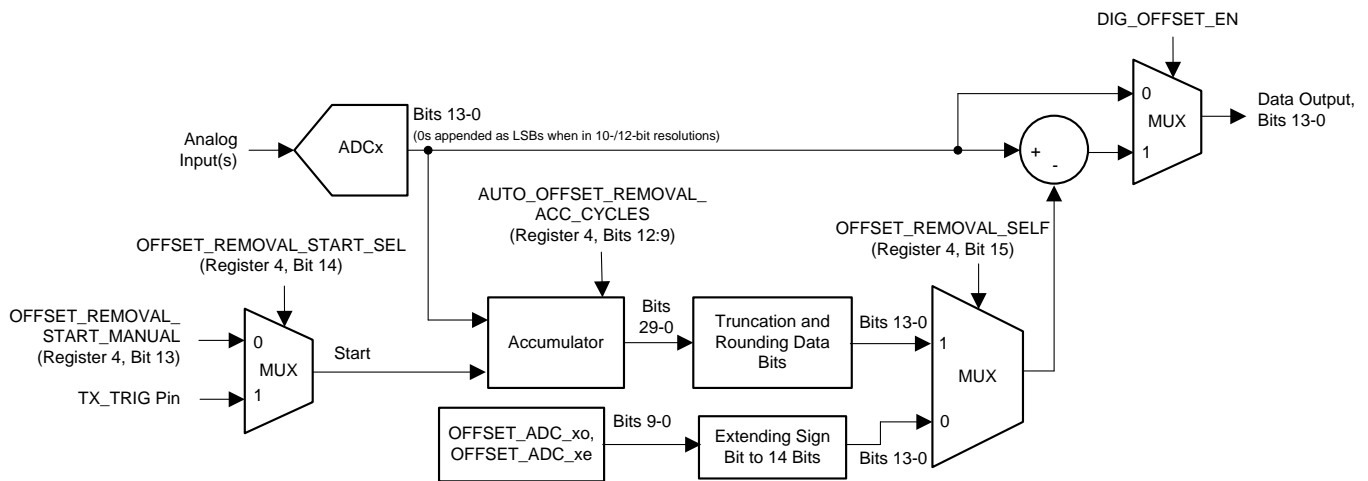
The auto offset calculation module can be used to calculate the channel offset that is then subtracted from the ADC output. To enable the auto offset correction mode, set the OFFSET_REMOVAL_SELF bit and DIG_OFFSET_EN bit to 1.

In auto offset correction mode the dc component of the ADC output (assumed to be the channel offset) is estimated using a digital accumulator. The ADC output sample set used by the accumulator is determined by a start time or first sample and number of samples to be used. A high pulse on the TX_TRIG pin or setting the OFFSET_REMOVAL_START_MANUAL register can be used to determine the first sample to the accumulator. To set the number of samples, the AUTO_OFFSET_REMOVAL_ACC_CYCLES register must be programmed according to [表 7](#).

If a pulse on the TX_TRIG pin is used to set the first sample, additional flexibility in setting the first sample is provided. A programmable delay between the TX_TRIG pulse and the first sample can be set by writing to the OFFSET_CORR_DELAY_FROM_TX_TRIG register.

The determined offset value can be read out for each channel. Set the channel number in the AUTO_OFFSET_REMOVAL_VAL_RD_CH_SEL register and read the offset value for the corresponding channel in the AUTO_OFFSET_REMOVAL_VAL_RD register. Note that the offset estimation is done separately for the odd and even data streams of each of the 16 ADCs and results in 32 sets of offset estimates that can be read out.

表 7. Auto Offset Removal Accumulator Cycles

| AUTO_OFFSET_REMOVAL_ACC_CYCLES (Bits 3-0) | NUMBER OF SAMPLES USED FOR OFFSET VALUE EVALUATION |
|---|--|
| 0 | 2047 |
| 1 | 127 |
| 2 | 255 |
| 3 | 511 |
| 4 | 1023 |
| 5 | 2045 |
| 6 | 4095 |
| 7 | 8191 |
| 8 | 16383 |
| 9 | 32767 |
| 10 to 15 | 65535 |

8.3.5.1.3 Digital Averaging

The data from two adjacent ADCs (ADC1 and ADC2, ADC3 and ADC4, and so forth) can be averaged by enabling the AVG_EN bit. A scenario where this feature can be useful is where the same analog input is fed to two channels and their outputs are averaged to achieve approximately a 3-dB improvement in SNR. The mapping of DIGOUT to the ADC data is shown in [表 8](#).

表 8. Mapping of the DIGOUT Words to the ADC Outputs when Using Digital Averaging

| DIGOUT | RELATIONSHIP TO ADC DATA | LVDS PAIR THE DATA COME OUT ON | |
|----------|----------------------------|--------------------------------|-------------------|
| | | 1X DATA RATE MODE | 2X DATA RATE MODE |
| DIGOUT1 | Average of ADC1 and ADC2 | DOUT1 | DOUT1 |
| DIGOUT2 | Average of ADC3 and ADC4 | DOUT2 | |
| DIGOUT3 | Average of ADC5 and ADC6 | DOUT3 | DOUT2 |
| DIGOUT4 | Average of ADC7 and ADC8 | DOUT4 | |
| DIGOUT5 | Ignore | — | — |
| DIGOUT6 | Ignore | — | — |
| DIGOUT7 | Ignore | — | — |
| DIGOUT8 | Ignore | — | — |
| DIGOUT9 | Average of ADC9 and ADC10 | DOUT9 | DOUT9 |
| DIGOUT10 | Average of ADC11 and ADC12 | DOUT10 | |
| DIGOUT11 | Average of ADC13 and ADC14 | DOUT11 | DOUT10 |
| DIGOUT12 | Average of ADC15 and ADC16 | DOUT12 | |
| DIGOUT13 | Ignore | — | — |
| DIGOUT14 | Ignore | — | — |
| DIGOUT15 | Ignore | — | — |
| DIGOUT16 | Ignore | — | — |

8.3.5.1.4 Digital Gain

The digital gain block can be enabled using the DIG_GAIN_EN bit. When enabled, a digital gain programmable from 0 dB to 6 dB in steps of 0.2 dB can be applied. To enable individual digital gain control for each input in 32-input mode, a separate digital gain control is provided for the odd and even sample of each ADC. Therefore, there are 32 gain controls. When using 16-input mode, set the odd and even gain controls of the same ADC to the same value. When using 8-input mode, four sets of gain controls are to be set to the same value (the odd and even gains of adjacent ADCs; for instance, ADC1 and ADC2).

8.3.5.1.5 Digital HPF

A digital high-pass filter (HPF) can be enabled in the path of each ADC word. The enable control is shared between sets of four consecutive-numbered ADCs (ADC1-ADC4, ADC5-ADC8, ADC9-ADC12, and ADC13-ADC16). For example, DIG_HPF_EN_ADC1-4 enables the HPF in the paths of ADCOUT1, ADCOUT2, ADCOUT3, and ADCOUT4. The digital high-pass transfer function is determined by [公式 1](#):

$$Y(n) = \frac{2^k}{2^k + 1} [x(n) - x(n - 1) + y(n - 1)] \quad (1)$$

When DIG_HPFCORNER_EN_ADC1-4 is set, the value of K in [公式 1](#) is set by the HPFCORNER_ADC1-4 bits. The value of K can be programmed from 2 to 10. [表 9](#) shows the cutoff frequency as a function of K.

表 9. Digital HPF, –1-dB Corner Frequency versus K and f_s

| CORNER FREQUENCY (k) (HPFCORNER_ADCx Register) | CORNER FREQUENCY (kHz) | | |
|--|------------------------|-----------------|-----------------|
| | $f_s = 40$ MSPS | $f_s = 50$ MSPS | $f_s = 65$ MSPS |
| 2 | 2780 | 3480 | 4520 |
| 3 | 1490 | 1860 | 2420 |
| 4 | 738 | 230 | 1200 |
| 5 | 369 | 461 | 600 |
| 6 | 185 | 230 | 300 |
| 7 | 111 | 138 | 180 |
| 8 | 49 | 61 | 80 |
| 9 | 25 | 30 | 40 |
| 10 | 12. | 15 | 20 |

By default the HPF output is truncated to 14 bits. To enable the rounding operation to map the HPF output to the ADC resolution, set the HPF_ROUND_EN_CH1-8 and HPF_ROUND_EN_CH9-16 bits to 1.

8.3.6 Data Formatting

The data formatting block does two functions: truncation and test pattern insertion. The serialization block following the data formatting block performs a parallel-to-serial conversion of the input word. The serialization factor is programmable to 10, 12, 14, or 16. The truncation block truncates the DIGOUT signal to the number of bits specified by the serialization factor. The number of bits in DIGRES1 to DIGRES16 is therefore determined by the serialization factor. Again, some of the bits in DIGRES may always be zero, depending on the combination of ADC resolution, what digital features are enabled or disabled, and the serialization factor that is programmed. To aid the FPGA in capturing and deserializing the serial output, the device includes provisions to replace the ADC data with test patterns. The SERIAL_IN1 to SERIAL_IN16 signals are the same as the DIGRES1 to DIGRES16 signals during normal operation. When a test pattern is programmed, the DIGRES signals are replaced with the appropriate test pattern. The manner in which a given test pattern actually comes out of the LVDS lines can be altered based on the serializer operating mode because the serializer itself has multiple modes (LSB-, MSB-first modes and 1X, 2X data rate modes).

8.3.7 Serializer and LVDS Interface

By default, each serializer takes in one SERIAL_IN word and performs a parallel-to-serial conversion. This mode is referred to as the *1X data rate mode*. In the 1X data rate mode, all 16 LVDS pairs are active and each pair corresponds to the data coming out of one ADC. In the 2X data rate mode (set using the LVDS_RATE_2X bit), the data from a pair of ADCs (two SERIAL_IN words) is packed into the same serial stream. In 2X mode, half the LVDS pairs are idle and can be powered down. The 2X data rate mode causes the LVDS interface to run at twice the rate but results in power saving. See the [Timing Requirements: Signal Chain](#) table for speed restrictions when using the 1X and 2X data rate modes.

The LVDS interface is a clock-data-frame (CDF) format, and has a frame clock and a high-speed bit clock in addition to the serial data lines.

The frequency of the bit clock with respect to the conversion clock frequency depends on the serialization factor (set using the SER_DATA_RATE bits), as shown in 表 10. Note that the serialized data are meant to be captured on both the rising and falling edges of the bit clock. Thus, the serialized data rate is twice the bit clock frequency.

表 10. Bit Clock Rate Relationship to the Conversion Clock and System Clock Rates

| SERIALIZATION FACTOR | DATA RATE MODE | BIT CLOCK RATE (f_B in Terms of f_C) | BIT CLOCK RATE (f_B in Terms of f_S) | | |
|----------------------|----------------|--|--|-----------------|------------------|
| | | | 16-INPUT MODE | 32-INPUT MODE | 8-INPUT MODE |
| 10 | 1X | $5 \times f_C$ | $5 \times f_S$ | $5 \times f_S$ | $2.5 \times f_S$ |
| | 2X | $10 \times f_C$ | $10 \times f_S$ | $10 \times f_S$ | $5 \times f_S$ |
| 12 | 1X | $6 \times f_C$ | $6 \times f_S$ | $6 \times f_S$ | $3 \times f_S$ |
| | 2X | $12 \times f_C$ | $12 \times f_S$ | $12 \times f_S$ | $6 \times f_S$ |
| 14 | 1X | $7 \times f_C$ | $7 \times f_S$ | $7 \times f_S$ | $3.5 \times f_S$ |
| | 2X | $14 \times f_C$ | $14 \times f_S$ | $14 \times f_S$ | $7 \times f_S$ |
| 16 | 1X | $8 \times f_C$ | $8 \times f_S$ | $8 \times f_S$ | $4 \times f_S$ |
| | 2X | $16 \times f_C$ | $16 \times f_S$ | $16 \times f_S$ | $8 \times f_S$ |

The relationship of the frame clock frequency to the conversion clock frequency for the three input modes is as shown in 表 11. The relationship of the frame clock frequency to the system clock (and conversion clock) frequencies is the same between the 1X and 2X data rate modes.

表 11. Relation of Frame Clock Rate to the Conversion Clock and System Clock Rates

| ANALOG INPUT MODE (Number of Channels) | FRAME CLOCK RATE (f_F in Terms of f_C) | FRAME CLOCK RATE (f_F in Terms of f_S) | DATA RATE MODES SUPPORTED |
|--|--|--|---------------------------|
| 16 | f_C | f_S | 1X, 2X |
| 32 | $0.5 \times f_C$ | $0.5 \times f_S$ | 1X |
| 8 | f_C | $0.5 \times f_S$ | 1X, 2X |

The serialization schemes for the various modes are illustrated in 图 64 to 图 68. Note that although the signals marked *ADCx Conversion* in 图 64 to 图 68 represent a multi-bit digital word, the SERIAL_OUTx signals are actually serialized representations of the correspondingly colored signals. For example, the blue-colored section in the SERIAL_OUT1 signal in 图 64 contains the serial stream of data that originated from the word corresponding to ADC1o.



图 64. ADC to Output Mapping in 16-Input, 1X Mode in LVDS Interface Mode



图 65. ADC to Output Mapping in 8-Input, 1X Mode in LVDS Interface Mode

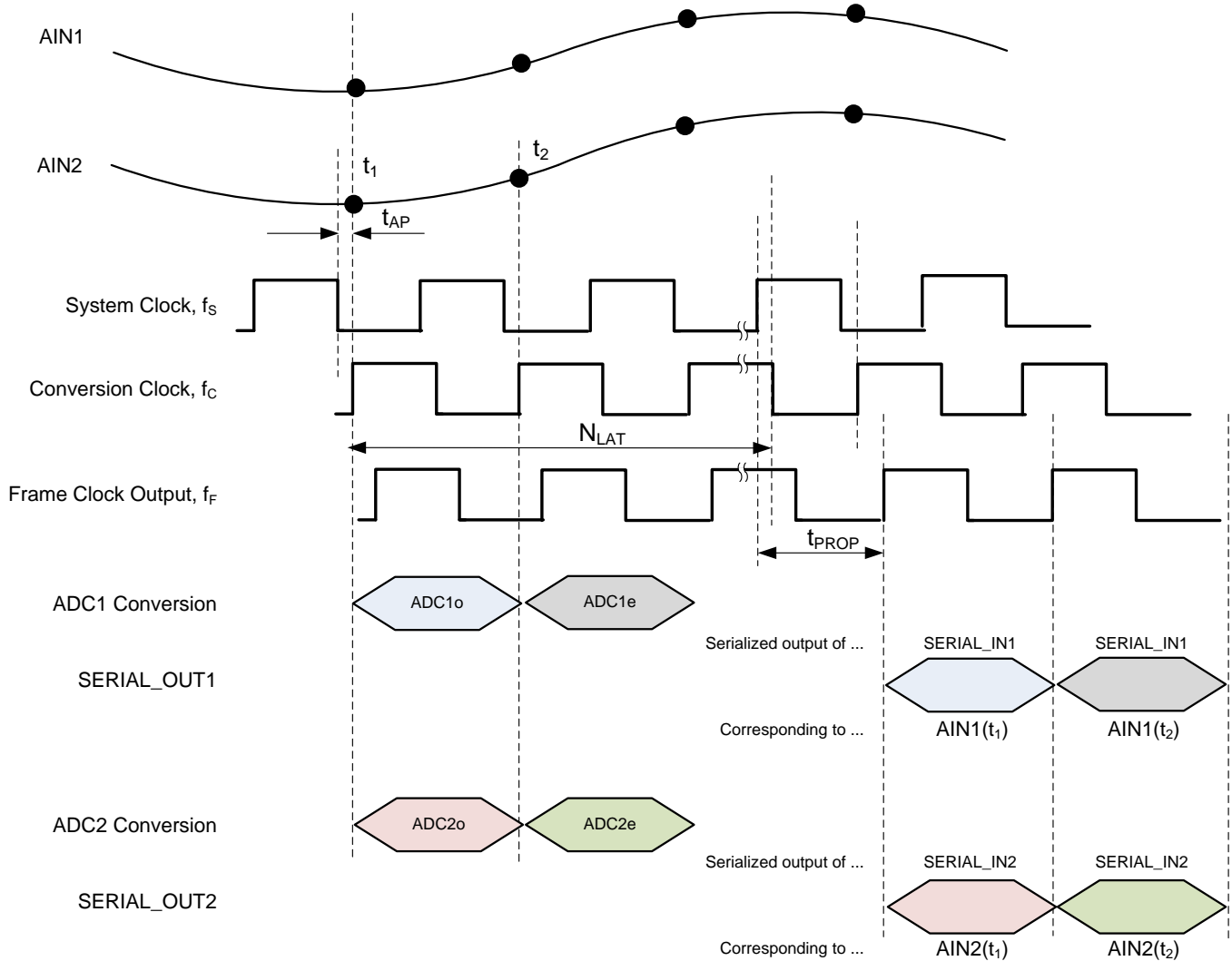

图 66. ADC to Output Mapping in 16-Input, 2X Mode in LVDS Interface Mode

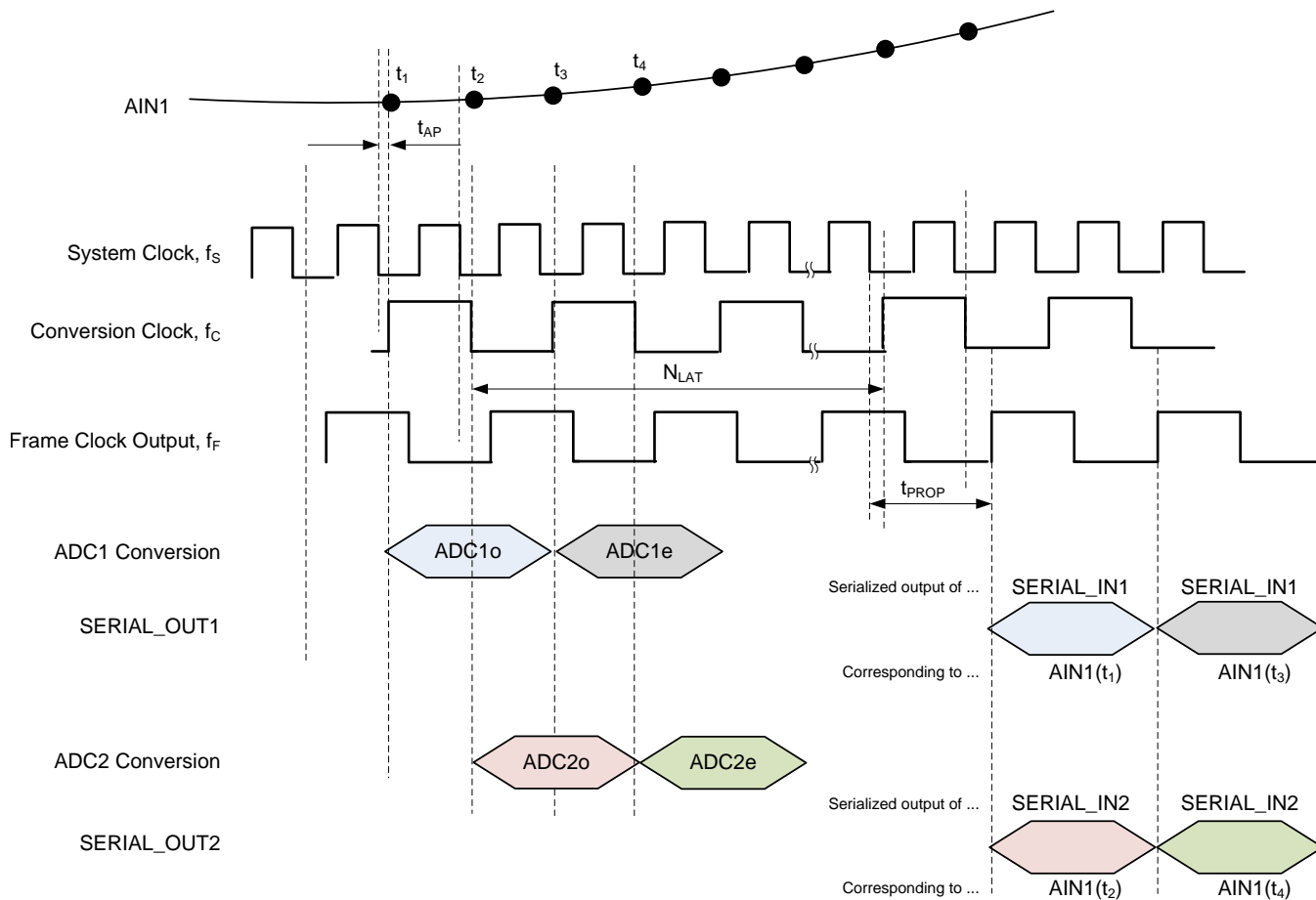

图 67. ADC to Output Mapping in 8-Input, 2X Mode in LVDS Interface Mode

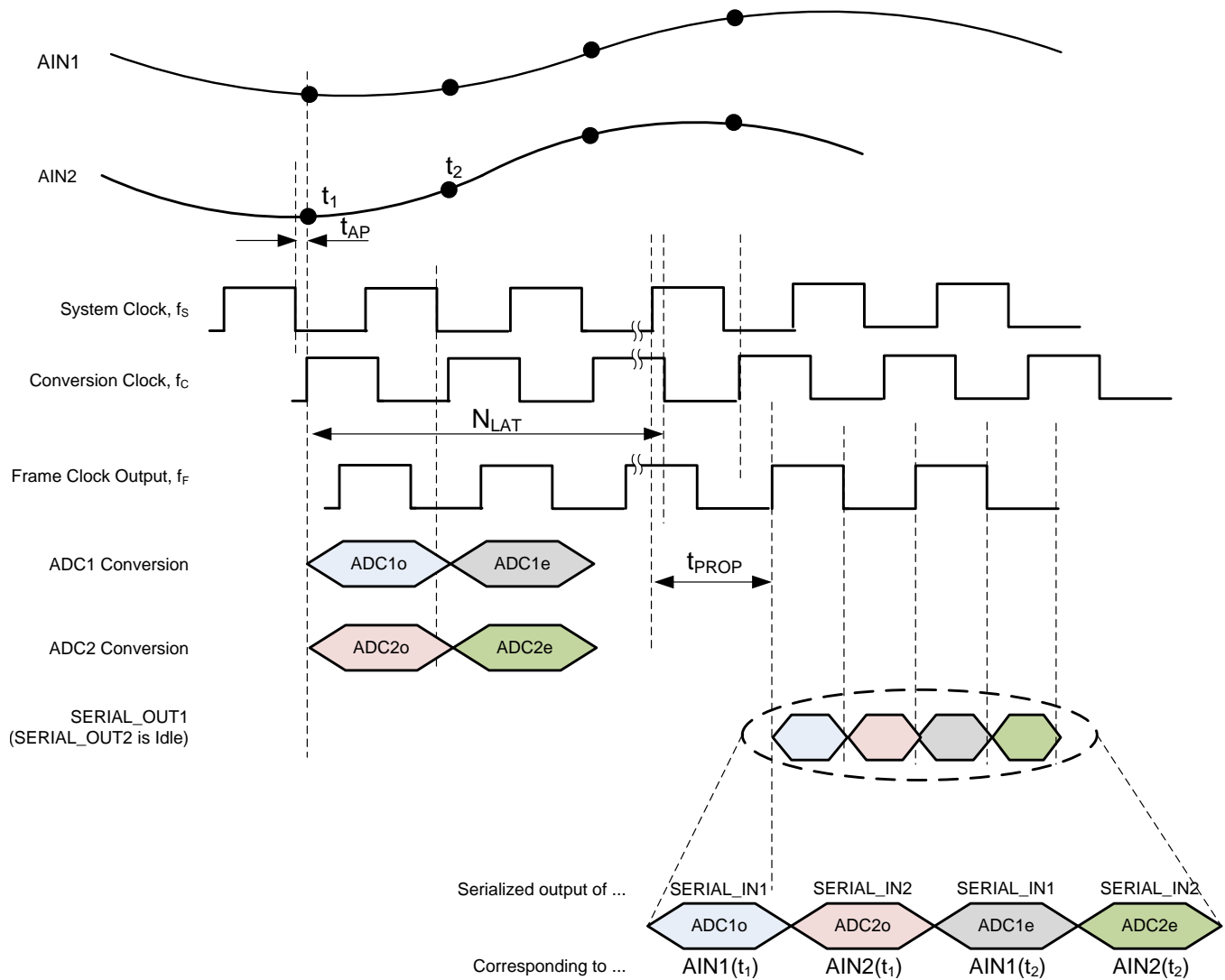

图 68. ADC to Output Mapping in 32-Input, 1X Mode in LVDS Interface Mode

The mapping of the subsequent-numbered ADC signals to subsequent-numbered SERIAL_OUT signals follows the same pattern as indicated previously.

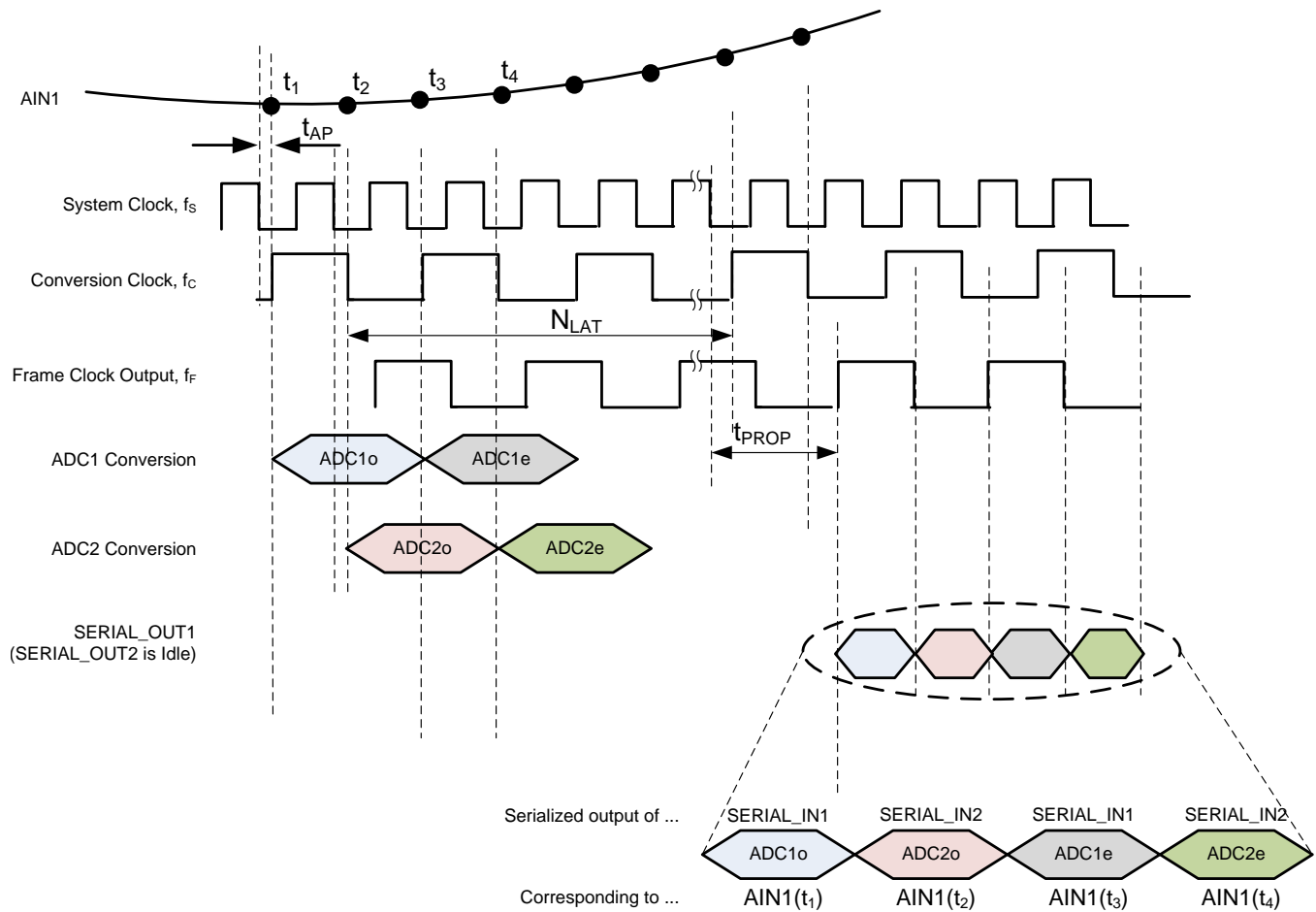
The serialized stream in SERIAL_OUT is a serialized representation of SERIAL_IN, which is the input word coming into the serializer. By default, serialization is done LSB-first. By setting the MSB_FIRST bit, serialization can be set to MSB-first.

The alignment of the frame clock, bit clock, and the serialized output data is illustrated in 图 1 for 16-input mode where the serialization factor is set to 12 bit, serialization is LSB-first, and the data rate is set to 1X mode.

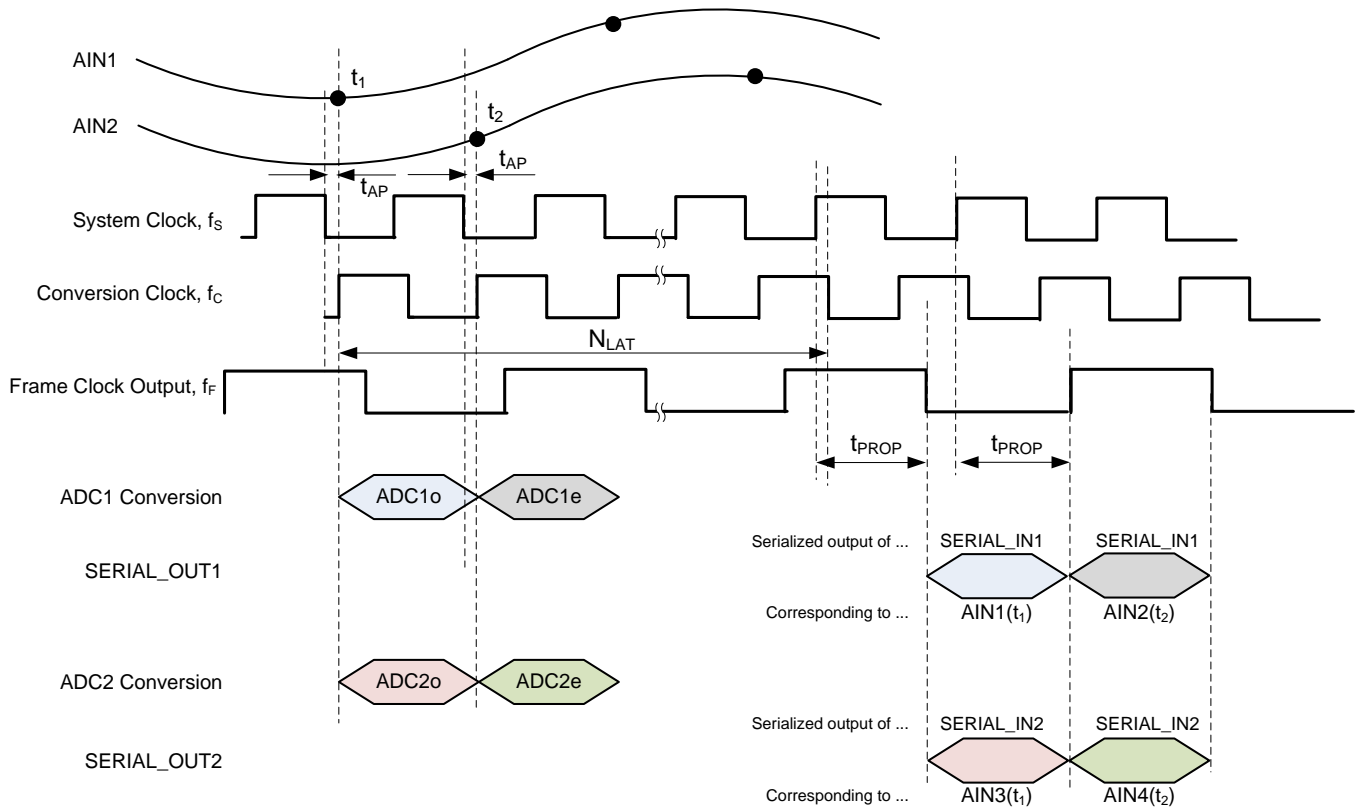
Another case is shown in 图 69 for 16-input mode. Here, the serialization factor is set to 14 bit, serialization is MSB-first, and the data rate is set to 2X mode.



图 69. LVDS Output Signals Timing Diagram in 16-Input Mode with 14-Bit Serialization, MSB-First, 2X Data Rate Mode

The serialized signals come out on the DOUT pins as indicated in [表 12](#). The buffers marked *Idle* can be powered down using the appropriate register bits to save power.

表 12. Mapping of the Serialized Outputs to the DOUT Pins

| LVDS OUTPUT PIN (DOUT) | OUTPUT SIGNAL | |
|------------------------|-------------------|-------------------|
| | 1X DATA RATE MODE | 2X DATA RATE MODE |
| DOUT1 | SERIAL_OUT1 | SERIAL_OUT1 |
| DOUT2 | SERIAL_OUT2 | SERIAL_OUT3 |
| DOUT3 | SERIAL_OUT3 | SERIAL_OUT5 |
| DOUT4 | SERIAL_OUT4 | SERIAL_OUT7 |
| DOUT5 | SERIAL_OUT5 | Idle |
| DOUT6 | SERIAL_OUT6 | Idle |
| DOUT7 | SERIAL_OUT7 | Idle |
| DOUT8 | SERIAL_OUT8 | Idle |
| DOUT9 | SERIAL_OUT9 | SERIAL_OUT9 |
| DOUT10 | SERIAL_OUT10 | SERIAL_OUT11 |
| DOUT11 | SERIAL_OUT11 | SERIAL_OUT13 |
| DOUT12 | SERIAL_OUT12 | SERIAL_OUT15 |
| DOUT13 | SERIAL_OUT13 | Idle |
| DOUT14 | SERIAL_OUT14 | Idle |
| DOUT15 | SERIAL_OUT15 | Idle |
| DOUT16 | SERIAL_OUT16 | Idle |

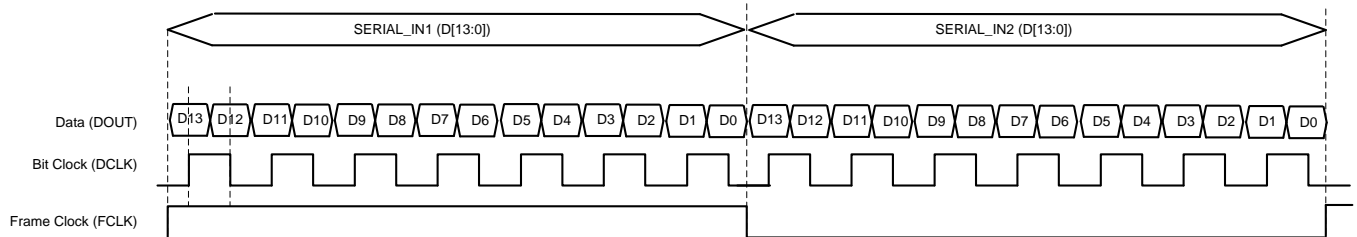
8.3.8 LVDS Buffers

A graphical representation of the 18 LVDS output buffers is shown in [图 70](#).



图 70. LVDS Output

The equivalent circuit of each LVDS output buffer is shown in 图 71. The buffer is designed for a differential output impedance of $100\ \Omega$ (R_{OUT}). The differential outputs can be terminated at the receiver end by a $100\text{-}\Omega$ termination. The buffer output impedance functions like a source-side series termination. By absorbing reflections from the receiver end, the buffer output impedance helps improve signal integrity.

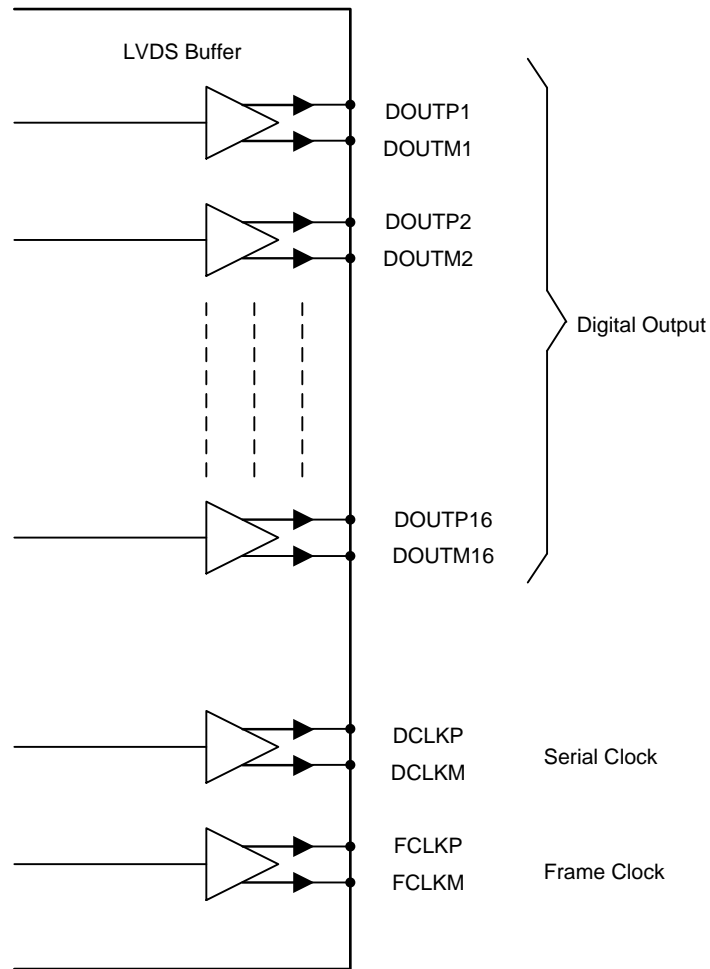
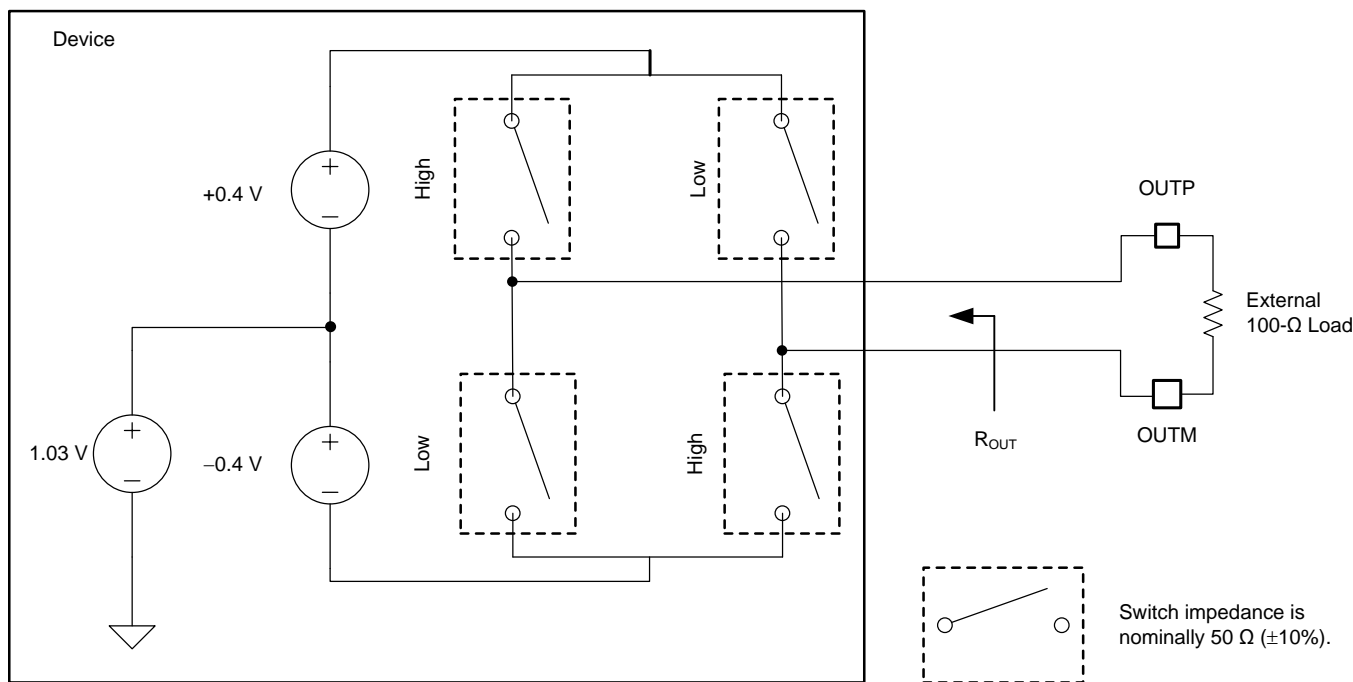

NOTE: When either the high or low switches are closed, differential $R_{OUT} = 100\ \Omega$.

图 71. LVDS Output Circuit

8.3.9 JESD204B Interface

8.3.9.1 Overview

When operating in 16-input and 32-input modes, the device supports a multi-lane output interface based on the JEDEC standard: JESD204B (serial interface for data converters). This interface runs up to 5 Gbps and provides a compact way of routing the data from multiple ADCs in the device to the FPGA. Subclasses 0, 1, and 2 of the JESD204B interface are supported. The block diagram in 图 72 illustrates the connections of the JESD interface to the rest of the device. After the test pattern insertion block, the parallel data streams SERIAL_IN1 to SERIAL_IN16 can be routed to either the LVDS interface or to the JESD interface (or both). The ADC data can be sent out using the EN_JESD and DIS_LVDS controls. The LVDS_INx and CML_INx words are the same as the SERIAL_INx words.



图 72. JESD 接口连接到数字处理输出

The JESD interface can be enabled by setting the EN_JESD bit to 1. When in JESD mode, the LVDS interface can be disabled by setting the DIS_LVDS bit to 1. Both the LVDS and JESD interfaces can be simultaneously kept active by setting the DIS_LVDS bit to 0 and the EN_JESD bit to 1.

表 13 shows the clock rates corresponding to the various clocks mentioned in the JESD204B document. This mapping is independent of whether the device operates in 8-, 16-, or 32-input mode.

表 13. Mapping of JESD204B Clock Notation to the Clock Rates

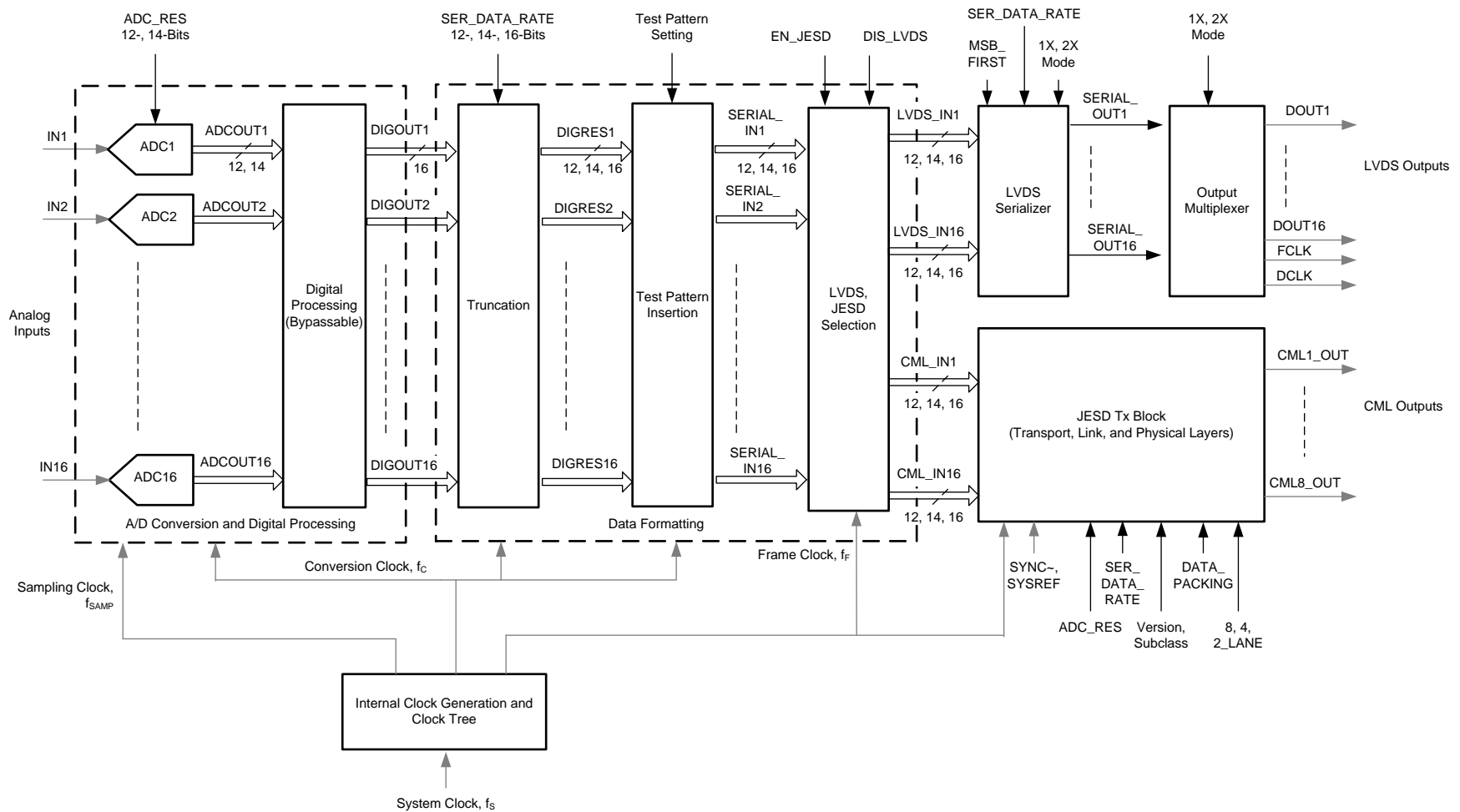
| CLOCK NOTATION IN JESD204B DOCUMENT | CORRESPONDING CLOCK RATE |
|-------------------------------------|--------------------------|
| Device clock | f_s |
| Frame clock | f_C |
| Conversion clock | f_C |
| Sample clock | f_C |

All mandatory features of the JESD204B interface are supported by the device, and are:

- Breaking up of data from the ADCs into octets.
- Optional scrambling of octets to avoid spectral tones.
- Conversion of (scrambled) octets to 10-bit words using 8b, 10b encoding.
- Parallel-to-serial conversion of octets.
- A code group synchronization (CGS) phase to enable the receiver to synchronize to the frame boundaries.
- An initial lane alignment (ILA) sequence phase to help the receiver align the data from all lanes and also for the receiver to read and verify the link configuration parameters.
- Character replacement at frame and multi-frame boundaries during normal data transmission to enable the receiver to monitor frame alignment.
- Mechanism to achieve deterministic latency across the link using the SYSREF signal in subclass 1 and the SYNC~ signal in subclass 2.

The [Link Configuration](#) section details only the device-specific implementation aspects of the JESD204B interface. For additional details related to the standard, see the JEDEC standard 204B (July 2011).

8.3.9.2 Link Configuration

The JESD204B link in the device can be configured to operate in different modes using the register controls in [表 14](#).

表 14. Register Controls Determining Link Configuration Parameters

| REGISTER CONTROL | DESCRIPTION | ALLOWED SETTINGS |
|------------------|---|------------------|
| NUM_ADC_PER_LANE | Number of ADC words packed into one lane | 2, 4, 8 |
| ADC_RES | Number of bits resolution in the ADC word input to the JESD transmitter block | 10, 12, 14, 16 |
| SER_DATA_RATE | Serialization factor control | 10, 12, 14, 16 |

In addition to the register controls mentioned in [表 14](#), the SING_CONV_PER_OCT register bit controls the packaging efficiency of the ADC data into octets.

The link configuration parameters are determined by [表 15](#).

表 15. Link Configuration Parameters

| LINK CONFIGURATION PARAMETER | | | | | LINK CONFIGURATION FIELD | |
|------------------------------|-------------------------------------|--|---|--|-----------------------------|--------------------------------|
| LINK CONFIGURATION PARAMETER | DESCRIPTION | ALLOWED VALUES (Decimal) | DEFAULT VALUE (In Decimal, Unless Otherwise Specified) ⁽¹⁾ | METHOD OF SETTING | CORRESPONDING FIELD IN ILAS | RELATION OF FIELD TO PARAMETER |
| ADJCNT | Not relevant | 0 | 0 | Forced to 0; not used | ADJCNT[3:0] | Binary value |
| ADJDIR | Not relevant | 0 | 0 | Forced to 0; not used | ADJDIR[0] | Binary value |
| BID | Bank ID | 0...15 | 0 | BANK_ID register control | BID[3:0] | Binary value |
| CF | Number of control words per frame | 0 | 0 | Forced to 0 | CF[4:0] | Binary value |
| CS | Number of control bits per sample | 0 | 0 | Forced to 0 | CS[1:0] | Binary value |
| DID | Device ID | 0...255 | 0 | DEVICE_ID register control | DID[7:0] | Binary value |
| F | Number of octets per frame | See 表 18 | 6 | Determined by 表 18 | F[7:0] | Binary value minus 1 |
| HD | High density format | 0 | 0 | Forced to 0; not used | HD[0] | Binary value |
| JESDV | JESD204 version | 0 = JESD204A 1 = JESD204B | 1 | ENABLE_JESD_VER_CONTROL, JESD_VERSION register control; see 表 16 | JESDV[2:0] | Binary value |
| K | Number of frames per multiframe | See 表 16 | 3 | Determined by 表 29; can be changed using FORCE_K and K_VALUE_TO_FORCE register controls | K[4:0] | Binary value minus 1 |
| L | Number of lanes | 2, 4, 8 | 4 | Determined by 表 18 | L[4:0] | Binary value minus 1 |
| LID | Lane ID | 1 to 8 | As given in 表 5 | Default (value given in 表 17) can be changed using EN_LANE_ID# and LANE_ID# register controls for each lane number | LID[4:0] | Binary value |
| M | Number of ADCs | 16 | 16 | Forced to 16 | M[7:0] | Binary value minus 1 |
| N | ADC resolution | 10, 12, 14, 16 | 12 | Determined by ADC_RES register control | N[4:0] | Binary value minus 1 |
| N' | Total number of bits per sample | See 表 18 | 12 | Determined by 表 18 | N'[4:0] | Binary value minus 1 |
| PHADJ | Not relevant | 0 | 0 | Forced to 0; not used | PHADJ[0] | Binary value |
| S | Number of samples per ADC per frame | 1 | 1 | Forced to 1 | S[4:0] | Binary value minus 1 |
| SCR | Scrambler enable or disable | 0,1 | 0 | SCR_EN register control | SCR[0] | Binary value |
| SUBCLASSV | Device subclass version | 0 = Subclass 0 1 = Subclass 1 2 = Subclass 2 | 1 | ENABLE_JESD_VER_CONTROL, JESD_SUBCLASS register control; see 表 16 | SUBCLASSV[2:0] | Binary value |
| RES1 | Reserved field 1 | 0 | 0 | Forced to 0 | RES1[7:0] | Binary value |
| RES2 | Reserved field 2 | 0 | 0 | Forced to 0 | RES2[7:0] | Binary value |
| CHKSUM | Checksum | — | Lane 1 – 32h Lane 3 – 34h Lane 5 – 36h Lane 7 – 38h | Default value as calculated by device can be changed using EN_CHECKSUM_LANE# and CHECK_SUM# for each lane number | FCHK[7:0] | Binary value |

(1) Corresponding to ADC_RES set to 12 bits, SER_DATA_RATE set to 12 bits, NUM_ADC_PER_LANE set to four ADCs per lane, SING_CONV_PER_OCT mode disabled, and ENABLE_JESD_VER_CONTROL set to 0 (to operate in JESD204B-subclass1).

8.3.9.3 JESD Version and Subclass

The interface can be configured to operate either as a JESD204A version or as a JESD204B version. Furthermore, when operating as a JESD204B version, the subclass can be configured as subclass 0, 1, or 2. The register controls for programming the version and subclass are shown in [表 16](#).

表 16. JESD Version and Subclass Control

| ENABLE_JESD_VER_CONTROL | JESD_VERSION | JESD_SUBCLASS | JESD VERSION | FIELD VALUE | |
|-------------------------|------------------|---------------|---------------------|--------------|------------------|
| | | | | JESD VERSION | SUBCLASS VERSION |
| 0 | X ⁽¹⁾ | X | JESD204B-subclass1 | 001 | 001 |
| 1 | 000 | 000 | JESD204A | 000 | 000 |
| 1 | 001 | 000 | JESD204B-subclass 0 | 001 | 000 |
| 1 | 001 | 001 | JESD204B-subclass 1 | 001 | 001 |
| 1 | 001 | 010 | JESD204B-subclass 2 | 001 | 010 |

(1) X = don't care.

8.3.9.4 Transport Layer

In the JESD204B transport layer, the incoming stream of ADC samples are mapped to one or more parallel lanes and grouped into a frame of F octets for transmission on each lane. Additional tail bits can be appended to the ADC samples.

8.3.9.4.1 User Data Format

The interface can be configured to operate in 2, 4, or 8 lane modes (L = 2, 4, or 8). Depending on the number of lanes used, the data from the 16 ADCs comes out in the different lanes as shown in [表 17](#).

表 17. Lane Mapping to CML Pins⁽¹⁾

| DEFAULT LANE ID | MAPPING TO THE PINS | 2 ADCS PER LANE (8-Lane Mode) ⁽²⁾ | 4 ADCS PER LANE (4-Lane Mode) ⁽²⁾ | 8 ADCS PER LANE (2-Lane Mode) ⁽²⁾ |
|-----------------|---------------------|--|--|--|
| 1 | CML1_OUTP-CML1_OUTM | ADC1, ADC2 | ADC1...ADC4 | ADC1...ADC8 |
| 2 | CML2_OUTP-CML2_OUTM | ADC3, ADC4 | — | — |
| 3 | CML3_OUTP-CML3_OUTM | ADC5, ADC6 | ADC5...ADC8 | — |
| 4 | CML4_OUTP-CML4_OUTM | ADC7, ADC8 | — | — |
| 5 | CML5_OUTP-CML5_OUTM | ADC9, ADC10 | ADC9...ADC12 | ADC9...ADC16 |
| 6 | CML6_OUTP-CML6_OUTM | ADC11, ADC12 | — | — |
| 7 | CML7_OUTP-CML7_OUTM | ADC13, ADC14 | ADC13...ADC16 | — |
| 8 | CML8_OUTP-CML8_OUTM | ADC15, ADC16 | — | — |

(1) More accurately, ADC1...ADC16 corresponds to CML_IN1...CML_IN16 as illustrated in [图 72](#).

(2) Determined by the NUM_ADC_PER_LANE register control.

The unused lanes are automatically powered down.

The device supports several combinations of ADC resolutions and number of lanes. There are no control bits or control words (CF = 0). The device has two modes of data packing: normal packing mode and single converter per octet mode. The packing mode can be chosen using the SING_CONV_PER_OCT register control. The number of ADCs per lane can be programmed to 8, 4, or 2 using the NUM_ADC_PER_LANE register control. The number of ADCs per lane automatically determines the value of L (the number of lanes). The values of N' and F for the different modes are described in [表 18](#).

表 18. Different JESD204B Interface Modes of Operation

| NUMBER OF ADCS PER LANE, N _{AL} ⁽¹⁾ | SER_DATA_RATE, N _{SER} ⁽¹⁾⁽²⁾ (Bits) | ADC_RES, N _{RES} ⁽¹⁾ (Bits) | L ⁽³⁾ (Lanes) | N ⁽³⁾ (Resolution of ADC Word Input to the JESD204B Transmitter) | NORMAL PACKING MODE ⁽¹⁾ | | SINGLE CONVERTER PER OCTET MODE ⁽¹⁾ | |
|---|--|---|--------------------------|---|---|-------------------------------------|--|-------------------------------------|
| | | | | | N ⁽³⁾ (Total Number of Bits) | F ⁽³⁾ (Octets per Frame) | N ⁽³⁾ (Total Number of Bits) | F ⁽³⁾ (Octets per Frame) |
| 8 | 10, 12, 14, 16 | 10, 12, 14, 16 | 2 | ADC_RES | SER_DATA_RATE ⁽⁴⁾ | SER_DATA_RATE | 16 | 16 ⁽⁵⁾ |
| 4 | 10, 12, 14, 16 | 10, 12, 14, 16 | 4 | ADC_RES | SER_DATA_RATE ⁽⁴⁾ | SER_DATA_RATE/2 | 16 | 8 ⁽⁵⁾ |
| 2 | 10 | 10 | 8 | ADC_RES | 12 | 3 ⁽⁶⁾ | 16 | 4 ⁽⁵⁾ |
| | 12 | 10, 12 | | ADC_RES | 12 | 3 | 16 | 4 ⁽⁵⁾ |
| | 14 | 10, 12, 14 | | ADC_RES | 16 | 4 ⁽⁶⁾ | 16 | 4 ⁽⁵⁾ |
| | 16 | 10, 12, 14, 16 | | ADC_RES | 16 | 4 | 16 | 4 ⁽⁵⁾ |

- (1) Value or mode is set by programming the appropriate registers.
- (2) SER_DATA_RATE must be greater than or equal to ADC_RES.
- (3) Automatically calculated and set by the device.
- (4) When SER_DATA_RATE > ADC_RES, then each ADC word is additionally padded with the (SER_DATA_RATE – ADC_RES) number of zeros on the LSB side to create the JESD ADC word. Each JESD ADC word is broken up into nibbles. Incomplete nibbles (if any) are stuffed with the starting bits of the subsequent JESD ADC word for maximum data packing.
- (5) Each ADC sample is broken into two octets; the incomplete octet is completed using zeros as tail bits.
- (6) Each ADC sample is broken into nibbles; incomplete nibbles are completed using zeros as tail bits.

The data packing modes are described in 表 19 to 表 24 for different modes of operation. Lane 1 is used for illustration purposes in these tables.

表 19. Data Packing in Normal Packing Mode for N_{AL} = 8 and N_{RES} = N_{SER}⁽¹⁾

| OCTET | N _{RES} = 10, N _{SER} = 10 | | N _{RES} = 12, N _{SER} = 12 | | N _{RES} = 14, N _{SER} = 14 | | N _{RES} = 16, N _{SER} = 16 | |
|-------|--|-------------------------|--|------------|--|---------------------------|--|------------|
| | NIBBLE 1 | NIBBLE 2 | NIBBLE 1 | NIBBLE 2 | NIBBLE 1 | NIBBLE 2 | NIBBLE 1 | NIBBLE 2 |
| 1 | ADC1[9:6] | ADC1[5:2] | ADC1[11:8] | ADC1[7:4] | ADC1[13:10] | ADC1[9:6] | ADC1[15:12] | ADC1[11:8] |
| 2 | ADC1[1:0], ADC2[9:8] | ADC2[7:4] | ADC1[3:0] | ADC2[11:8] | ADC1[5:2] | ADC1[1:0], ADC2[13:12] | ADC1[7:4] | ADC1[3:0] |
| 3 | ADC2[3:0] | ADC3[9:6] | ADC2[7:4] | ADC2[3:0] | ADC2[11:8] | ADC2[7:4] | ADC2[15:12] | ADC2[11:8] |
| 4 | ADC3[5:2] | ADC3[1:0], ADC4[9:8] | ADC3[11:8] | ADC3[7:4] | ADC2[3:0] | ADC3[13:10] | ADC2[7:4] | ADC2[3:0] |
| 5 | ADC4[7:4] | ADC4[3:0] | ADC3[3:0] | ADC4[11:8] | ADC3[9:6] | ADC3[5:2] | ADC3[15:12] | ADC3[11:8] |
| 6 | ADC5[9:6] | ADC5[5:2] | ADC4[7:4] | ADC4[3:0] | ADC3[1:0], ADC4[13:12] | ADC4[11:8] | ADC3[7:4] | ADC3[3:0] |
| 7 | ADC5[1:0], ADC6[9:8] | ADC6[7:4] | ADC5[11:8] | ADC5[7:4] | ADC4[7:4] | ADC4[3:0] | ADC4[15:12] | ADC4[11:8] |
| 8 | ADC6[3:0] | ADC7[9:6] | ADC5[3:0] | ADC6[11:8] | ADC5[13:10] | ADC5[9:6] | ADC4[7:4] | ADC4[3:0] |
| 9 | ADC7[5:2] | ADC7[1:0], ADC8[9:8] | ADC6[7:4] | ADC6[3:0] | ADC5[5:2] | ADC5[1:0], ADC6[13:12] | ADC5[15:12] | ADC5[11:8] |
| 10 | ADC7[7:4] | ADC8[3:0] | ADC7[11:8] | ADC7[7:4] | ADC6[11:8] | ADC6[7:4] | ADC5[7:4] | ADC5[3:0] |
| 11 | — | — | ADC7[3:0] | ADC8[11:8] | ADC6[3:0] | ADC7[13:10] | ADC6[15:12] | ADC6[11:8] |
| 12 | — | — | ADC8[7:4] | ADC8[3:0] | ADC7[9:6] | ADC7[5:2] | ADC6[7:4] | ADC6[3:0] |
| 13 | — | — | — | — | ADC7[1:0], ADC8[13:12] | ADC8[11:8] | ADC7[15:12] | ADC7[11:8] |
| 14 | — | — | — | — | ADC8[7:4] | ADC8[3:0] | ADC7[7:4] | ADC7[3:0] |
| 15 | — | — | — | — | — | — | ADC8[15:12] | ADC8[11:8] |
| 16 | — | — | — | — | — | — | ADC8[7:4] | ADC8[3:0] |

- (1) A similar data packing scheme is used for other lanes with the mapping of ADCs per lane as indicated in 表 17.

表 20. Data Packing in Normal Packing Mode for $N_{AL} = 8$ and $N_{SER} > N_{RES}$ ⁽¹⁾

| OCTET | $N_{RES} = 10, N_{SER} = 12$ | | $N_{RES} = 12, N_{SER} = 14$ | | $N_{RES} = 14, N_{SER} = 16$ | |
|-------|------------------------------|---------------|------------------------------|----------------|------------------------------|---------------|
| | NIBBLE 1 | NIBBLE 2 | NIBBLE 1 | NIBBLE 2 | NIBBLE 1 | NIBBLE 2 |
| 1 | ADC1[9:6] | ADC1[5:2] | ADC1[11:8] | ADC1[7:4] | ADC1[13:10] | ADC1[9:6] |
| 2 | ADC1[1:0], 00 | ADC2[9:6] | ADC1[3:0] | 00,ADC2[11:10] | ADC1[5:2] | ADC1[1:0], 00 |
| 3 | ADC2[5:2] | ADC2[1:0], 00 | ADC2[9:6] | ADC2[5:2] | ADC2[13:10] | ADC2[9:6] |
| 4 | ADC3[9:6] | ADC3[5:2] | ADC2[1:0],00 | ADC3[11:8] | ADC2[5:2] | ADC2[1:0], 00 |
| 5 | ADC3[1:0], 00 | ADC4[9:6] | ADC3[7:4] | ADC3[3:0] | ADC3[13:10] | ADC3[9:6] |
| 6 | ADC4[5:2] | ADC4[1:0], 00 | 00,ADC4[11:10] | ADC4[9:6] | ADC3[5:2] | ADC3[1:0], 00 |
| 7 | ADC5[9:6] | ADC5[5:2] | ADC4[5:2] | ADC4[1:0],00 | ADC4[13:10] | ADC4[9:6] |
| 8 | ADC5[1:0], 00 | ADC6[9:6] | ADC5[11:8] | ADC5[7:4] | ADC4[5:2] | ADC4[1:0], 00 |
| 9 | ADC6[5:2] | ADC6[1:0], 00 | ADC5[3:0] | 00,ADC6[11:10] | ADC5[13:10] | ADC5[9:6] |
| 10 | ADC7[9:6] | ADC7[5:2] | ADC6[9:6] | ADC6[5:2] | ADC5[5:2] | ADC5[1:0], 00 |
| 11 | ADC7[1:0], 00 | ADC8[9:6] | ADC6[1:0],00 | ADC7[11:8] | ADC6[13:10] | ADC6[9:6] |
| 12 | ADC8[5:2] | ADC8[1:0], 00 | ADC7[7:4] | ADC7[3:0] | ADC6[5:2] | ADC6[1:0], 00 |
| 13 | — | — | 00,ADC8[11:10] | ADC8[9:6] | ADC7[13:10] | ADC7[9:6] |
| 14 | — | — | ADC8[5:2] | ADC8[1:0],00 | ADC7[5:2] | ADC7[1:0], 00 |
| 15 | — | — | — | — | ADC8[13:10] | ADC8[9:6] |
| 16 | — | — | — | — | ADC8[5:2] | ADC8[1:0], 00 |

(1) A similar data packing scheme is used for other lanes with the mapping of ADCs per lane as indicated in 表 17.

表 21. Data Packing in Normal Packing Mode for $N_{AL} = 4$ and $N_{RES} = N_{SER}$ ⁽¹⁾

| OCTET | $N_{RES} = 10, N_{SER} = 10$ | | $N_{RES} = 12, N_{SER} = 12$ | | $N_{RES} = 14, N_{SER} = 14$ | | $N_{RES} = 16, N_{SER} = 16$ | |
|-------|------------------------------|------------------------|------------------------------|------------|------------------------------|---------------------------|------------------------------|------------|
| | NIBBLE 1 | NIBBLE 2 | NIBBLE 1 | NIBBLE 2 | NIBBLE 1 | NIBBLE 2 | NIBBLE 1 | NIBBLE 2 |
| 1 | ADC1[9:6] | ADC1[5:2] | ADC1[11:8] | ADC1[7:4] | ADC1[13:10] | ADC1[9:6] | ADC1[15:12] | ADC1[11:8] |
| 2 | ADC1[1:0], ADC2[9:8] | ADC2[7:4] | ADC1[3:0] | ADC2[11:8] | ADC1[5:2] | ADC1[1:0], ADC2[13:12] | ADC1[7:4] | ADC1[3:0] |
| 3 | ADC2[3:0] | ADC3[9:6] | ADC2[7:4] | ADC2[3:0] | ADC2[11:8] | ADC2[7:4] | ADC2[15:12] | ADC2[11:8] |
| 4 | ADC3[5:2] | ADC3[1:0], AD4[9:8] | ADC3[11:8] | ADC3[7:4] | ADC2[3:0] | ADC3[13:10] | ADC2[7:4] | ADC2[3:0] |
| 5 | ADC4[7:4] | ADC4[3:0] | ADC3[3:0] | ADC4[11:8] | ADC3[9:6] | ADC3[5:2] | ADC3[15:12] | ADC3[11:8] |
| 6 | — | — | ADC4[7:4] | ADC4[3:0] | ADC3[1:0], ADC4[13:12] | ADC4[11:8] | ADC3[7:4] | ADC3[3:0] |
| 7 | — | — | — | — | ADC4[7:4] | ADC4[3:0] | ADC4[15:12] | ADC4[11:8] |
| 8 | — | — | — | — | — | — | ADC4[7:4] | ADC4[3:0] |

(1) A similar data packing scheme is used for other lanes with the mapping of ADCs per lane as indicated in 表 17.

表 22. Data Packing in Normal Packing Mode for $N_{AL} = 4$ and $N_{SER} > N_{RES}$ ⁽¹⁾

| OCTET | $N_{RES} = 10, N_{SER} = 12$ | | $N_{RES} = 12, N_{SER} = 14$ | | $N_{RES} = 14, N_{SER} = 16$ | |
|-------|------------------------------|---------------|------------------------------|----------------|------------------------------|---------------|
| | NIBBLE 1 | NIBBLE 2 | NIBBLE 1 | NIBBLE 2 | NIBBLE 1 | NIBBLE 2 |
| 1 | ADC1[9:6] | ADC1[5:2] | ADC1[11:8] | ADC1[7:4] | ADC1[13:10] | ADC1[9:6] |
| 2 | ADC1[1:0], 00 | ADC2[9:6] | ADC1[3:0] | 00,ADC2[11:10] | ADC1[5:2] | ADC1[1:0], 00 |
| 3 | ADC2[5:2] | ADC2[1:0], 00 | ADC2[9:6] | ADC2[5:2] | ADC2[13:10] | ADC2[9:6] |
| 4 | ADC3[9:6] | ADC3[5:2] | ADC2[1:0],00 | ADC3[11:8] | ADC2[5:2] | ADC2[1:0], 00 |
| 5 | ADC3[1:0], 00 | ADC4[9:6] | ADC3[7:4] | ADC3[3:0] | ADC3[13:10] | ADC3[9:6] |
| 6 | ADC4[5:2] | ADC4[1:0], 00 | 00,ADC4[11:10] | ADC4[9:6] | ADC3[5:2] | ADC3[1:0], 00 |
| 7 | — | — | ADC4[5:2] | ADC4[1:0],00 | ADC4[13:10] | ADC4[9:6] |
| 8 | — | — | — | — | ADC4[5:2] | ADC4[1:0], 00 |

(1) A similar data packing scheme is used for other lanes with the mapping of ADCs per lane as indicated in 表 17.

表 23. Data Packing in Normal Packing Mode for $N_{AL} = 2$ ⁽¹⁾

| OCTET | $N_{RES} = 10, N_{SER} = 10$ or 12 | | $N_{RES} = 12, N_{SER} = 12$ | | $N_{RES} = 14, N_{SER} = 14$ or 16 | | $N_{RES} = 16, N_{SER} = 16$ | |
|-------|------------------------------------|---------------|------------------------------|------------|------------------------------------|---------------|------------------------------|------------|
| | NIBBLE 1 | NIBBLE 2 | NIBBLE 1 | NIBBLE 2 | NIBBLE 1 | NIBBLE 2 | NIBBLE 1 | NIBBLE 2 |
| 1 | ADC1[9:6] | ADC1[5:2] | ADC1[11:8] | ADC1[7:4] | ADC1[13:10] | ADC1[9:6] | ADC1[15:12] | ADC1[11:8] |
| 2 | ADC1[1:0], 00 | ADC2[9:6] | ADC1[3:0] | ADC2[11:8] | ADC1[5:2] | ADC1[1:0], 00 | ADC1[7:4] | ADC1[3:0] |
| 3 | ADC2[5:2] | ADC3[1:0], 00 | ADC2[7:4] | ADC2[3:0] | ADC2[13:10] | ADC2[9:6] | ADC2[15:12] | ADC2[11:8] |
| 4 | — | — | — | — | ADC2[5:2] | ADC2[1:0], 00 | ADC2[7:4] | ADC2[3:0] |

(1) A similar data packing scheme is used for other lanes with the mapping of ADCs per lane as indicated in 表 17.

表 24. Data Packing in Single Converter per Octet Packing Mode for $N_{AL} = 8$ (Independent of N_{SER})⁽¹⁾⁽²⁾

| OCTET | $N_{RES} = 10$ | | $N_{RES} = 12$ | | $N_{RES} = 14$ | | $N_{RES} = 16, N_{SER} = 16$ | |
|-------|----------------|-----------|----------------|-----------|----------------|---------------|------------------------------|------------|
| | NIBBLE 1 | NIBBLE 2 | NIBBLE 1 | NIBBLE 2 | NIBBLE 1 | NIBBLE 2 | NIBBLE 1 | NIBBLE 2 |
| 1 | ADC1[9:6] | ADC1[5:2] | ADC1[11:8] | ADC1[7:4] | ADC1[13:10] | ADC1[9:6] | ADC1[15:12] | ADC1[11:8] |
| 2 | ADC1[1:0], 00 | 0000 | ADC1[3:0] | 0000 | ADC1[5:2] | ADC1[1:0], 00 | ADC1[7:4] | ADC1[3:0] |
| 3 | ADC2[9:6] | ADC2[5:2] | ADC2[11:8] | ADC2[7:4] | ADC2[13:10] | ADC2[9:6] | ADC2[15:12] | ADC2[11:8] |
| 4 | ADC2[1:0], 00 | 0000 | ADC2[3:0] | 0000 | ADC2[5:2] | ADC2[1:0], 00 | ADC2[7:4] | ADC2[3:0] |
| 5 | ADC3[9:6] | ADC3[5:2] | ADC3[11:8] | ADC3[7:4] | ADC3[13:10] | ADC3[9:6] | ADC3[15:12] | ADC3[11:8] |
| 6 | ADC3[1:0], 00 | 0000 | ADC3[3:0] | 0000 | ADC3[5:2] | ADC3[1:0], 00 | ADC3[7:4] | ADC3[3:0] |
| 7 | ADC4[9:6] | ADC4[5:2] | ADC4[11:8] | ADC4[7:4] | ADC4[13:10] | ADC4[9:6] | ADC4[15:12] | ADC4[11:8] |
| 8 | ADC4[1:0], 00 | 0000 | ADC4[3:0] | 0000 | ADC4[5:2] | ADC4[1:0], 00 | ADC4[7:4] | ADC4[3:0] |
| 9 | ADC5[9:6] | ADC5[5:2] | ADC5[11:8] | ADC5[7:4] | ADC5[13:10] | ADC5[9:6] | ADC5[15:12] | ADC5[11:8] |
| 10 | ADC5[1:0], 00 | 0000 | ADC5[3:0] | 0000 | ADC5[5:2] | ADC5[1:0], 00 | ADC5[7:4] | ADC5[3:0] |
| 11 | ADC6[9:6] | ADC6[5:2] | ADC6[11:8] | ADC6[7:4] | ADC6[13:10] | ADC6[9:6] | ADC6[15:12] | ADC6[11:8] |
| 12 | ADC6[1:0], 00 | 0000 | ADC6[3:0] | 0000 | ADC6[5:2] | ADC6[1:0], 00 | ADC6[7:4] | ADC6[3:0] |
| 13 | ADC7[9:6] | ADC7[5:2] | ADC7[11:8] | ADC7[7:4] | ADC7[13:10] | ADC7[9:6] | ADC7[15:12] | ADC7[11:8] |
| 14 | ADC7[1:0], 00 | 0000 | ADC7[3:0] | 0000 | ADC7[5:2] | ADC7[1:0], 00 | ADC7[7:4] | ADC7[3:0] |
| 15 | ADC8[9:6] | ADC8[5:2] | ADC8[11:8] | ADC8[7:4] | ADC8[13:10] | ADC8[9:6] | ADC8[15:12] | ADC8[11:8] |
| 16 | ADC8[1:0], 00 | 0000 | ADC8[3:0] | 0000 | ADC8[5:2] | ADC8[1:0], 00 | ADC8[7:4] | ADC8[3:0] |

(1) For $N_{AL} = 4$, use the first eight octets. For $N_{AL} = 2$, use the first four octets.

(2) A similar data packing scheme is used for other lanes with the mapping of ADCs per lane as indicated in 表 17.

Tail bits (in modes where applicable) are set to 0. There is no option for a pseudo-random generator for generating the tail bits. When a converter is powered down, the corresponding sample is replaced by a dummy sample that corresponds to all zeros. There is no option for a pseudo-random generator for generating the dummy samples. The value S (number of samples per ADC per frame minus 1) is always 0 and HD mode is not supported.

8.3.9.4.2 Transport Layer Test Patterns

All test patterns described in the *LVDS Test Pattern Mode* section can be set, even with the JESD204B interface. These test patterns serve as transport layer test modes for the JESD interface. These test patterns can replace the normal ADC data going into the JESD204B link layer.

8.3.9.5 Scrambler

An optional scrambler is implemented in the device using the polynomial as defined in the JESD204B standard. The scrambler can be enabled using the SCR_EN register control. The scrambler is bypassed during the code group synchronization and transmission of the initial lane alignment sequence. There is no alternate scrambler to keep processing the user data during these states.

8.3.9.6 Data Link Layer

The data link layer of the JESD204B block handles various functions (such as the 8b, 10b encoding of the input octets, code group synchronization (CGS), transmission of an initial lane alignment (ILA) sequence, frame alignment character replacement, and transmission of link layer test patterns). As specified by the standard, the device uses 8b, 10b coding to encode the data before being transmitted. The frame contents are processed from MSB to LSB.

8.3.9.6.1 Code Group Synchronization (CGS)

In the CGS state, the device transmits a set of /K28.5/ characters that are used by the receiver to recover the clock and data from the serial stream using a clock and data recovery (CDR) circuit, and also to align to the symbol boundaries. The device enters the CGS state when it receives an active (low going) SYNC pulse that is at least four device clocks wide. In addition, when the device is in the CGS state as defined by the JESD204B standard, the device can also be made to transmit a stream of /K28.5/ symbols by programming the TX_SYNC_REQ register control.

8.3.9.6.2 Initial Lane Alignment (ILA)

By default, the CGS phase is followed by the transmission of an ILA sequence. The ILA transmission can be disabled using the LINK_CONFIG_DIS register control. Transitioning from a CGS state to an ILA sequence state occurs on the local multiframe clock (LMFC) boundary. By default, the transition occurs at the first LMFC boundary after SYNC~ is deasserted. However, the transition point can be delayed to the second, third, or fourth LMFC edge by programming the RELEASE_ILA register control to 1, 2, or 3, respectively. This mode can be used to provide sufficient time to the receiver to achieve synchronization.

8.3.9.6.3 Lane and Frame Alignment Monitoring

The lane and frame alignment monitoring and character replacement are as per the JESD204B standard. The insertion of frame and lane alignment characters can be enabled by setting the LANE_ALIGN and FRAME_ALIGN register controls. These controls, in conjunction with the SCR_EN control, determine the mechanism of the lane and frame alignment character replacement, as shown in [表 25](#).

表 25. Character Replacement for Lane and Frame Alignment

| SCR_EN | FRAME_ALIGN | LANE_ALIGN | EFFECT ON LINK DATA |
|--------|-------------|------------|---|
| 0 | 0 | 0 | ADC data are sent without any character replacement. |
| 0 | 0 | 1 | If the last octet of the multiframe is the same as the last octet of the previous multiframe, then the last octet is replaced with /K28.3/. |
| 0 | 1 | 0 | If the last octet of the frame is the same as the last octet of the previous frame, then the last octet is replaced with /K28.7/. If an alignment character has already been sent in the previous frame, then no characters are replaced. |
| 0 | 1 | 1 | Frame and lane alignment character replacements are enabled. |
| 1 | 0 | 0 | ADC data are scrambled and sent without any character replacement. |
| 1 | 0 | 1 | If the last scrambled octet of the multiframe is D28.3, then that octet is replaced with /K28.3/. |
| 1 | 1 | 0 | If the last scrambled octet of the frame is D28.7, then that octet is replaced with /K28.7/. |
| 1 | 1 | 1 | Frame and lane alignment character replacements are enabled with scrambling. |

8.3.9.6.4 Link Layer Test Modes

The JESD link can be tested by transmitting predetermined 8b, 10b characters in all frames and on all lanes. Test modes can be enabled with the LINK_LAYER_TESTMODES register control. These test patterns are never scrambled. A pseudo-random pattern of 120 bits corresponds to the random pattern (RPAT). An additional PRBS pattern can be output by setting the transport layer test mode to a constant pattern and enabling the scrambler. A scrambled jitter pattern (JSPAT) is not supported.

8.3.9.7 Deterministic Latency

Deterministic latency is achieved in the subclass 1 and subclass 2 of the JESD204B standard through a local multiframe clock (LMFC) that is synchronized between the transmitter and receiver. The phase of the LMFC is dictated by the sampled SYSREF input in subclass 1 and by the SYNC~ rising edge in subclass 2.

8.3.9.7.1 Synchronization Using SYNC~ and SYSREF

In order to achieve deterministic latency across the entire link, the device supports system-level link synchronization using the SYNC~ (in subclass 2) and SYSREF (in subclass 1) signals, as mentioned in the JESD204B standards document. The mapping of these signals to the pin voltages is shown in [表 26](#).

表 26. Mapping of the JESD204B Signals to Device Pins

| SIGNAL NOTATION IN JESD204B DOCUMENT | RELATION TO DEVICE PINS |
|--------------------------------------|---------------------------------|
| Device clock | ADC_CLKP – ADC_CLKM |
| SYNC~ | SYNCP_SERDES – SYNCM_SERDES |
| SYSREF ⁽¹⁾ | SYSREFP_SERDES – SYSREFM_SERDES |

(1) Must be inactive (low) except when operating in JESD204B subclass 1.

JESD subclasses 1 and 2 use an internal clock called the local multiframe clock (LMFC) to achieve deterministic latency in the link. The phase of the LMFC clock is set based on the device clock rising edge that the SYSREF (in subclass 1) or SYNC~ (in subclass 2) signals are sampled on. The device clock is the highest speed input clock for the device and there is no provision for a higher speed adjustment clock to achieve phase adjustments finer than what is achievable using the device clock. By default, the LMFC count is reset to 0 during a SYNC~ or SYSREF event. This reset count can be forced to a different value by using the FORCE_LMFC_COUNT and LMFC_COUNTER_INIT_VALUE register controls. The LMFC does not exist in JESD subclass 0.

SYSREF can be a periodic, one-shot, or gapped periodic active-high signal that is sampled on the rising edge of the device clock. There is no option to sample the SYSREF signal on the falling edge of the device clock. If SYSREF is a periodic or gapped periodic signal, then its periodicity must be a multiple of the LMFC period in order to avoid unwanted sudden shifts in the phase of the LMFC. Note that a continuous periodic SYSREF can cause spurious degradation in the ADC performance because of energy coupling into the device at a rate that is a sub-harmonic of the device clock rate.

In addition to resetting the phase of the LMFC, SYSREF (or SYNC~) also resets some of the other internal clock dividers not related to the JESD block and affects the reset of the phase of the test pattern generator (see the [LVDS Test Pattern Mode](#) section). SYSREF (or SYNC~) also affects the reset of the frame clock phases and the odd or even sampling selection in 32-channel mode.

The default mode is to reset all internal dividers as well as the phase of the LMFC during every SYSREF (or SYNC~) event based on the JESD subclass.

The reset operations based on SYNC~ and SYSREF for the different subclasses occurs as shown in [表 27](#).

表 27. Reset Operations from SYNC~ or SYSREF in the Various JESD204B Subclasses

| SUBCLASS | EVENT CONTROLLING THE RESET | What gets reset | |
|---------------------|-----------------------------|--------------------------------------|----------------|
| | | JESD BLOCK (Phase of the LMFC Clock) | REST OF DEVICE |
| JESD204B-subclass 0 | SYNC~ rising edge | Not applicable | Yes |
| JESD204B-subclass 1 | SYSREF ⁽¹⁾ | Yes | Yes |
| JESD204B-subclass 2 | SYNC~ rising edge | Yes | Yes |
| JESD204A | SYNC~ rising edge | Not applicable | Yes |

(1) To avoid unexpected reset behavior, SYSREF must be active only when operating in JESD204B subclass 1.

表 28 lists the register controls to selectively mask the reset operations of the various blocks.

表 28. Masking of the Various Reset Operations Resulting from SYNC~ or SYSREF

| REGISTER BIT | MASKS RESET OPERATION IN | | |
|--------------|--------------------------------------|----------------|--------------------------------------|
| | JESD BLOCK (Phase of the LMFC Clock) | CLOCK DIVIDERS | OTHER SYNCHRONIZATION ⁽¹⁾ |
| JESD_RESET1 | No | Yes | Yes |
| JESD_RESET2 | Yes | Yes | No |

(1) Demodulators and test pattern generation.

The JESD_RESET1 and JESD_RESET2 bits mask the reset operations as indicated in 表 28 for all subsequent SYNC~ and SYSREF events after the bits are set. The JESD_RESET3 register bit is functionally similar to JESD_RESET2 (in terms of masking the reset function to the blocks). However, when JESD_RESET3 is set, this bit allows the first SYNC~ or SYSREF event to reset all clock dividers, takes affect, and masks the reset of the LMFC clock divider only after the first SYNC~ or SYSREF event occurs. The JESD_RESET1, JESD_RESET2, and JESD_RESET3 bits can be used appropriately to avoid unwanted reset operations resulting from SYNC~ and SYSREF events.

When SYSREF resets the rest of the device, the ADC data can be corrupted for four to six clocks. If SYSREF is periodic, then periodic corruption of ADC data can result. Thus, when using a periodic or a gapped periodic SYSREF, one JESD_RESET (JESD_RESET1, JESD_RESET2, or JESD_RESET3) must be set to 1.

8.3.9.7.2 Latency

图 73 到 图 76 illustrate the relevant latencies for the JESD interface with the default mode of operation (four ADCs per lane mode, $N_{ADC} = 12$, $N_{SER} = 12$, and $K = 3$) used for illustration purposes.

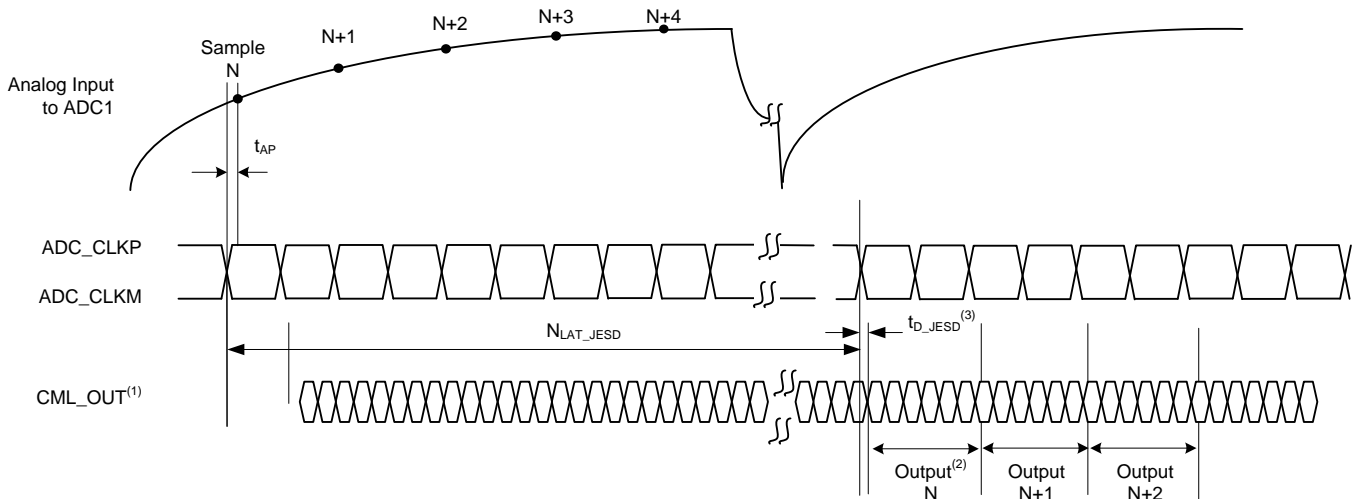

- (1) CML_OUT is shown broken in terms of octets.
- (2) The ADC word corresponding to ADC1 is contained in the first two octets of output N .
- (3) t_{D_JESD} is a small additional variable delay which is a fraction of the device clock period.

图 73. ADC Latency in JESD Mode

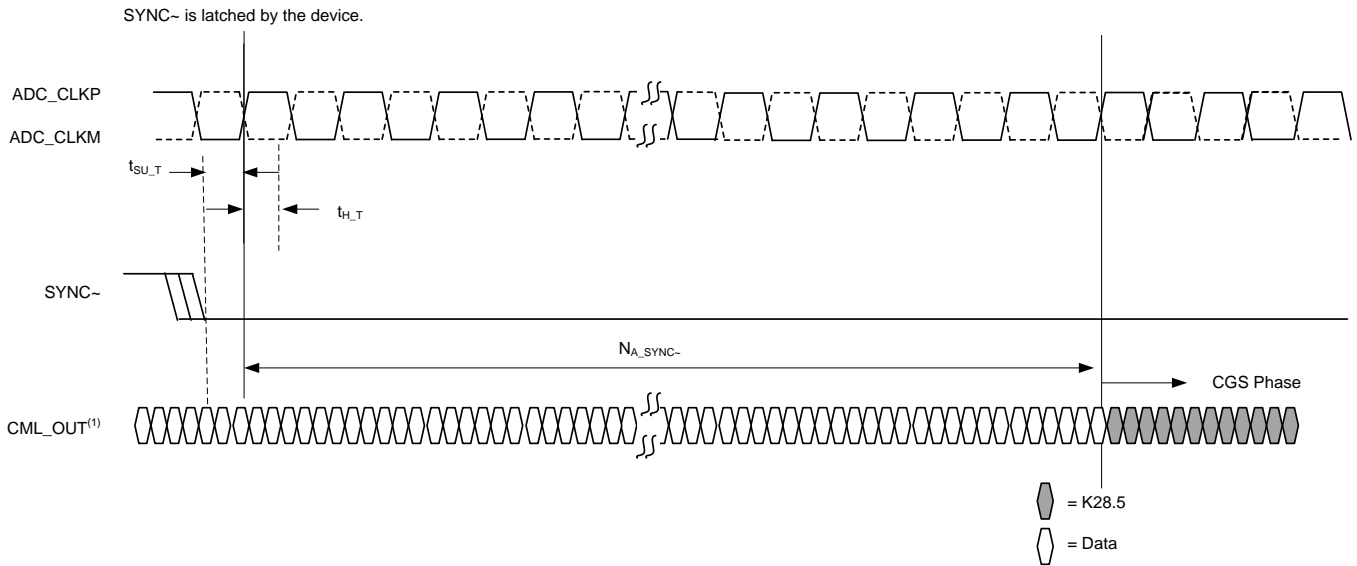

(1) CML_OUT is broken in terms of octets.

图 74. Latency from SYNC~ Assertion to Start of CGS Phase



图 75. Latency from SYNC~ Deassertion to Start of ILA Phase in Subclass 1



图 76. Latency from SYNC- Deassertion to Start of ILA Phase in Subclass 2

8.3.9.7.3 Multiframe Size

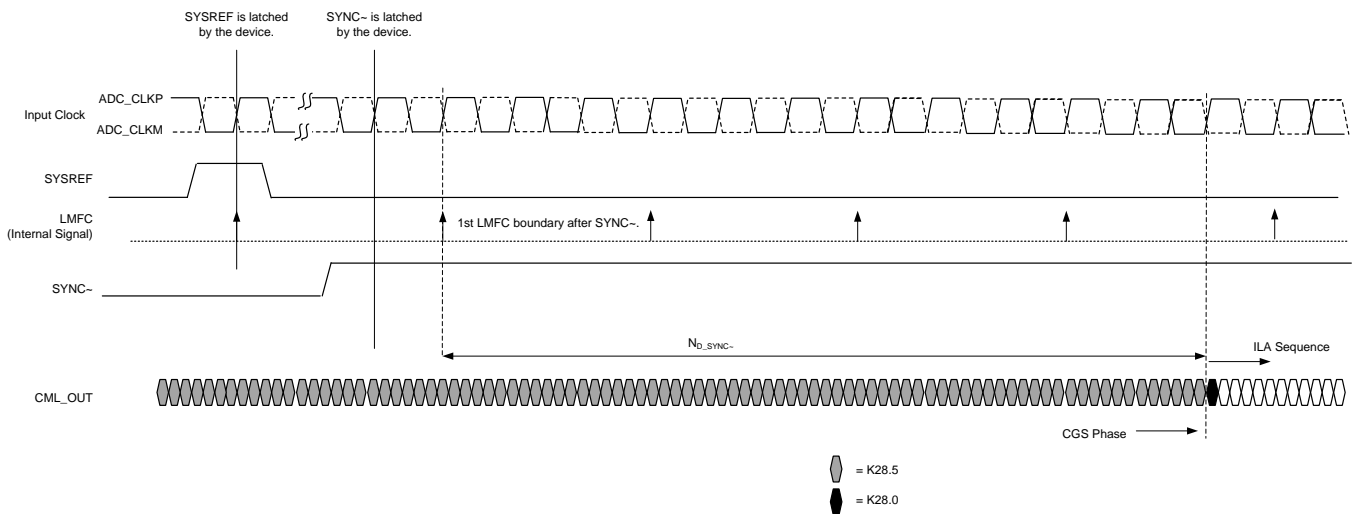
The size of the multiframe (as well as the periodicity of the LMFC clock) is denoted as K. Multiframe size is calculated as shown in 公式 2:

$$\text{Ceil}(17 / \text{Number of Octets per Frame}) \leq \text{Multiframe Size (In Terms of Number of Frames)} \tag{2}$$

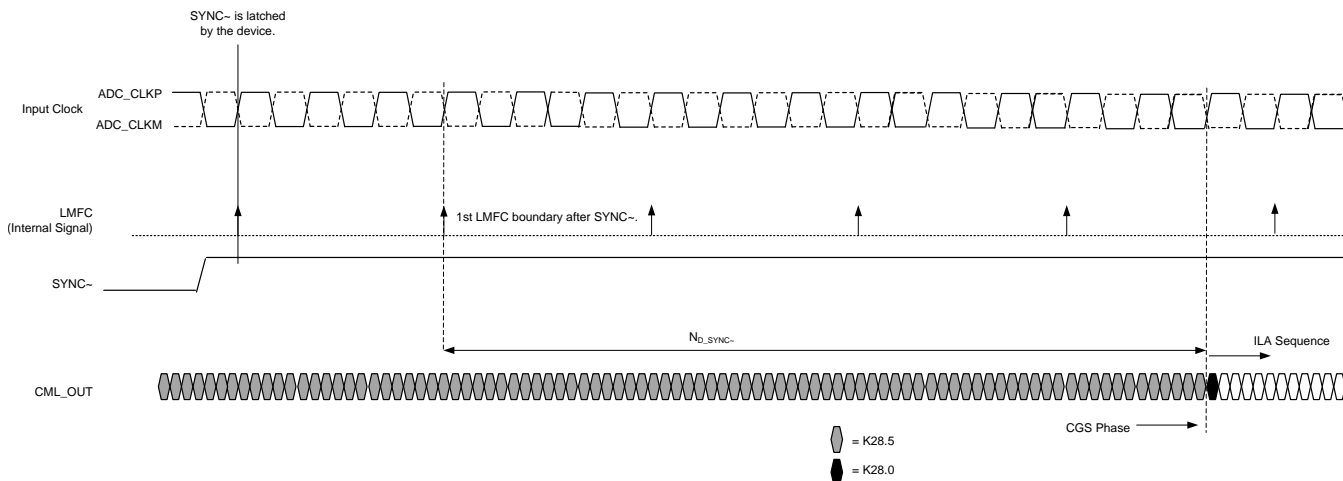
表 29 lists the multiframe size for different modes of operation.

表 29. Multiframe Size in Different Modes⁽¹⁾

| ADC RESOLUTION (Bits) | 2 ADCS PER LANE ⁽²⁾ | | | 4 ADCS PER LANE ⁽²⁾ | | | 8 ADCS PER LANE ⁽²⁾ | | |
|-----------------------|--------------------------------|-----------------|--------|--------------------------------|-----------------|--------|--------------------------------|-----------------|--------|
| | FRAME SIZE (Octets) | MULTIFRAME SIZE | | FRAME SIZE (Octets) | MULTIFRAME SIZE | | FRAME SIZE (Octets) | MULTIFRAME SIZE | |
| | | FRAMES | OCTETS | | FRAMES | OCTETS | | FRAMES | OCTETS |
| 12 | 3 | 6 | 18 | 6 | 3 | 18 | 12 | 2 | 24 |
| 14 | 4 | 5 | 20 | 7 | 3 | 21 | 14 | 2 | 28 |
| 16 | 4 | 5 | 20 | 8 | 3 | 24 | 16 | 2 | 32 |

(1) The decimal equivalent of K[4:0] in the link configuration parameter is equal to the multiframe size (in frames) minus 1.
 (2) Determined by the register control NUM_ADC_PER_LANE.

8.3.9.8 JESD Physical Layer

The JESD transmitter uses a PLL that runs off an internal low-dropout (LDO) regulator that provides noise rejection on the external 1.2-V supply. At higher speeds (beyond 4 Gbps), the LDO voltage drops because of increased switching currents. To improve the jitter at higher speeds, restore the LDO voltage with the INC_JESD_VDD register control.

8.3.9.8.1 CML Buffer

The device JESD204B transmitter uses differential CML output drivers with a typical current drive of 16 mA. The output driver includes an internal 50-Ω termination to the DVDD_1P2 supply. Additionally, external 50-Ω termination resistors connected to DVDD_1P2 must be placed close to the receiver pins. DC compliance to the standard is not ensured and ac coupling can be used to avoid the common-mode mismatch between the transmitter and receiver, as shown in [图 77](#).



图 77. CML Output Connections

The CML buffer also has a pre-emphasis control for improving the timing margins. Pre-emphasis is achieved by increasing the CML buffer current if the current transmitter bit is different from the previous one. The current of the CML buffer for a transitioning bit can be increased from the CML buffer current setting to one of 16 settings in steps of 0.25 mA using the PRE_EMP register control. Pre-emphasis is recommended to be used at higher speeds in order to improve the timing margins.

8.3.9.8.2 Jitter Considerations

Figure 78 shows the data eye measurement of the device JESD204B transmitter against the JESD204B transmitter eye mask at 3.125 Gbps.

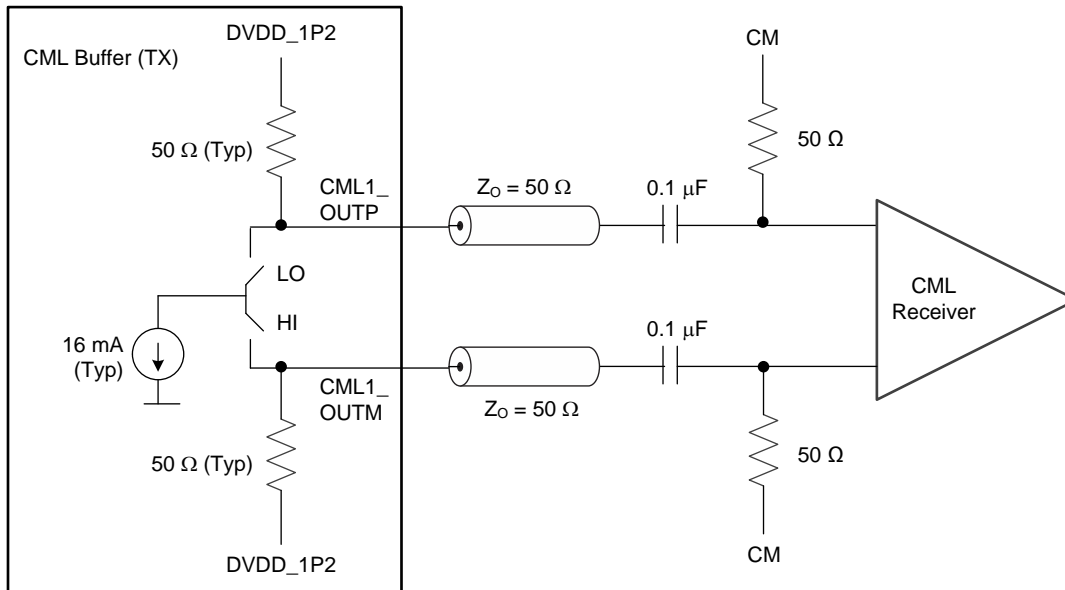

图 78. Eye Diagram at the CML Output at a Data Rate of 3.125 Gbps

图 79 shows the data eye measurement of the device JESD204B transmitter against the JESD204B transmitter eye mask at 5 Gbps. This measurement is taken with PRE_EMP set to 7.

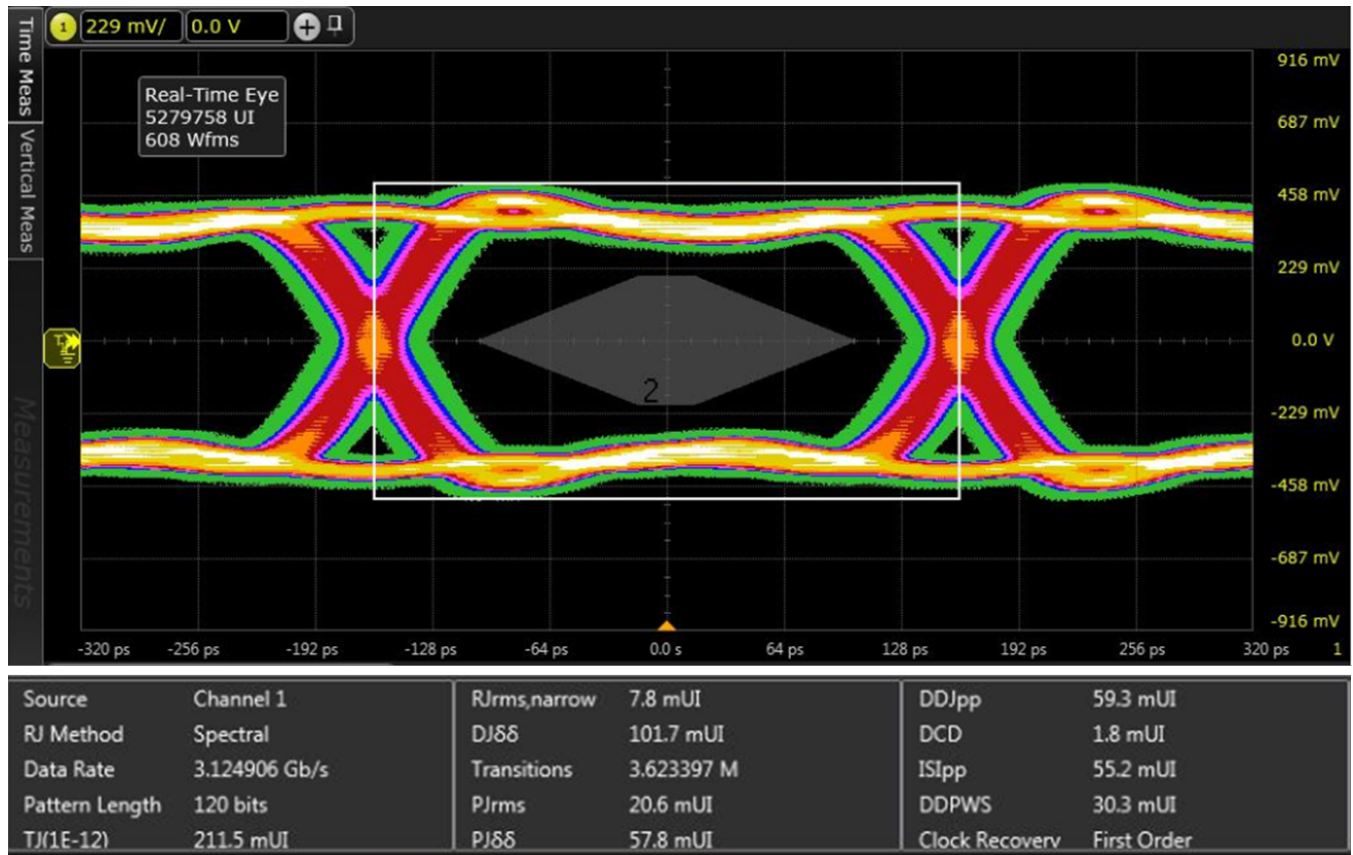

图 79. Eye Diagram at the CML Output at a Data Rate of 5 Gbps

The total jitter as a fraction of the UI changes with interface speed, pre-emphasis setting, and the length of the trace from the transmitter pins to the external termination resistor. The total jitter at the transmitter pins can exceed the transmitter eye mask specification for speeds beyond 5 Gbps. However, the interface can be made to work (and meet the eye mask specification at the receiver inputs) at speeds higher than 5 Gbps for short trace lengths. 图 40 illustrates the total jitter as a function of the trace length (between the transmitter pins and the termination resistor) for 5-Gbps, 6-Gbps, and 6.4-Gbps speeds. 图 41 to 图 43 illustrate the total jitter as a function of the trace length for different pre-emphasis settings at 5 Gbps, 6 Gbps, and 6.4 Gbps, respectively.

8.3.10 Interfacing SYNC~ and SYSREF Between the FPGA and ADCs

The SYNC~ and SYSREF signals must be connected to the FPGA and the multiple ADCs in the system. When driving SYNC~ and SYSREF using differential signals, additional interface circuits may be required to decouple the common-mode levels between the FPGA and the ADC. 图 80 shows an overview of such a scheme for driving the SYNC~ signal from the FPGA to multiple ADCs.

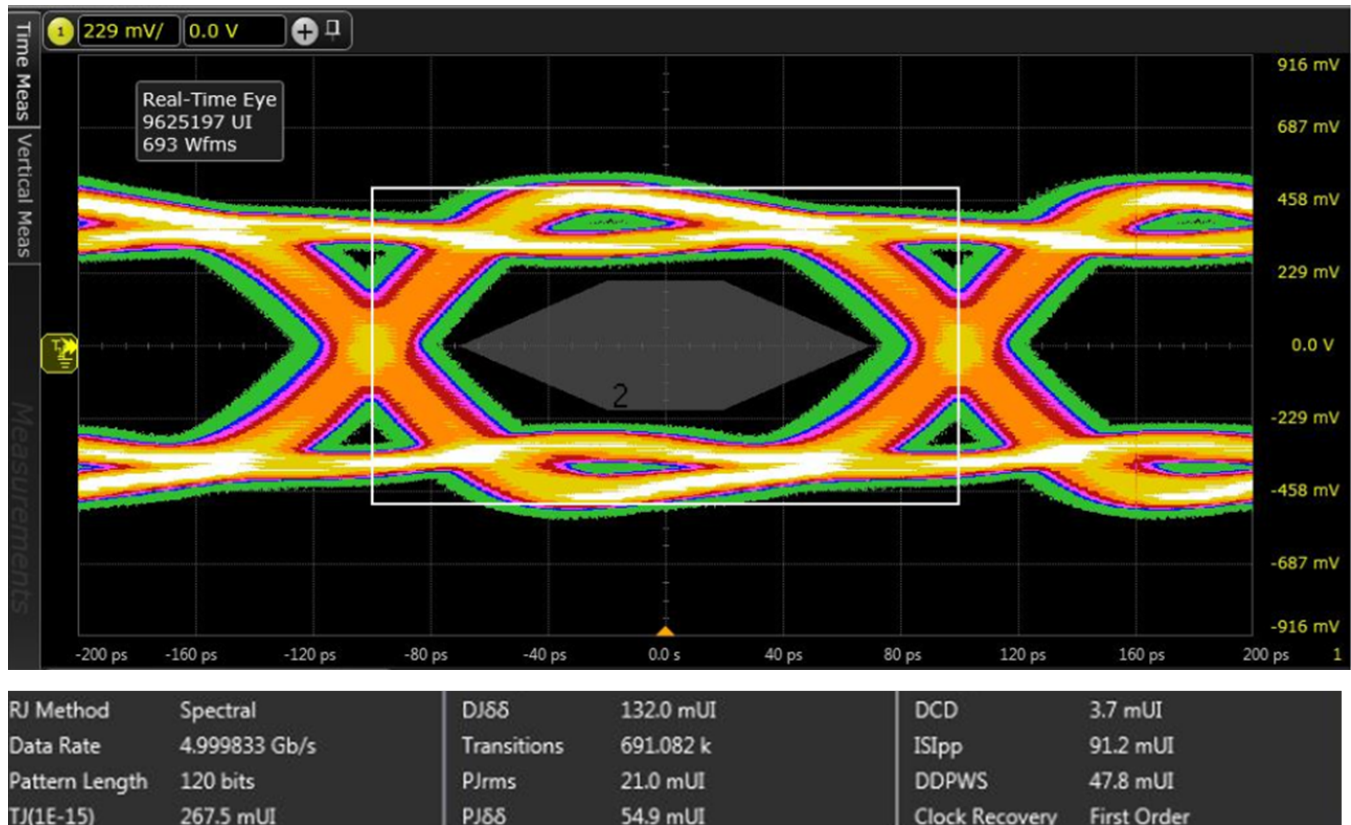

图 80. Connection of SYNC~ From the FPGA to the ADCs

The ADC has internal 5-k Ω resistors from the SYNCP and SYNCM pins to an internal reference voltage of 0.7 V. When driven by a differential driver, an interface circuit may be required to match the common-mode voltages between the driver and the ADC. An example circuit is shown in 图 81 to level-shift from a 1.2-V common-mode voltage at the driver output to the 0.7 V at the ADC input. The 100 Ω at the driver output depicts the differential termination and could be realized inside the FPGA.

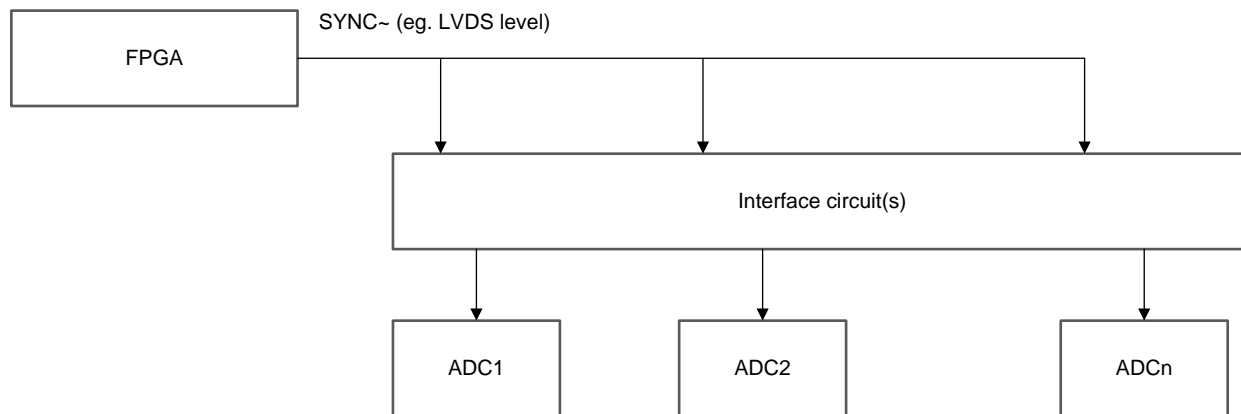

图 81. Circuit to Level-Shift the Common-Mode Voltage From 1.2 V at the Driver Output to 0.7 V at the ADC Input

For a different driver output common-mode than the one shown in 图 81, the interface circuit must be modified.

A similar circuit as shown in 图 81 can also be used to interface the SYSREF signals to the ADC. As shown in 图 82, the SYSREF signal can also be driven using an ac-coupling scheme. The external components are chosen for a case where the SYSREF source drives only one ADC. The values of these components must be changed if the signal is interfaced to multiple ADCs (contact the factory for details).

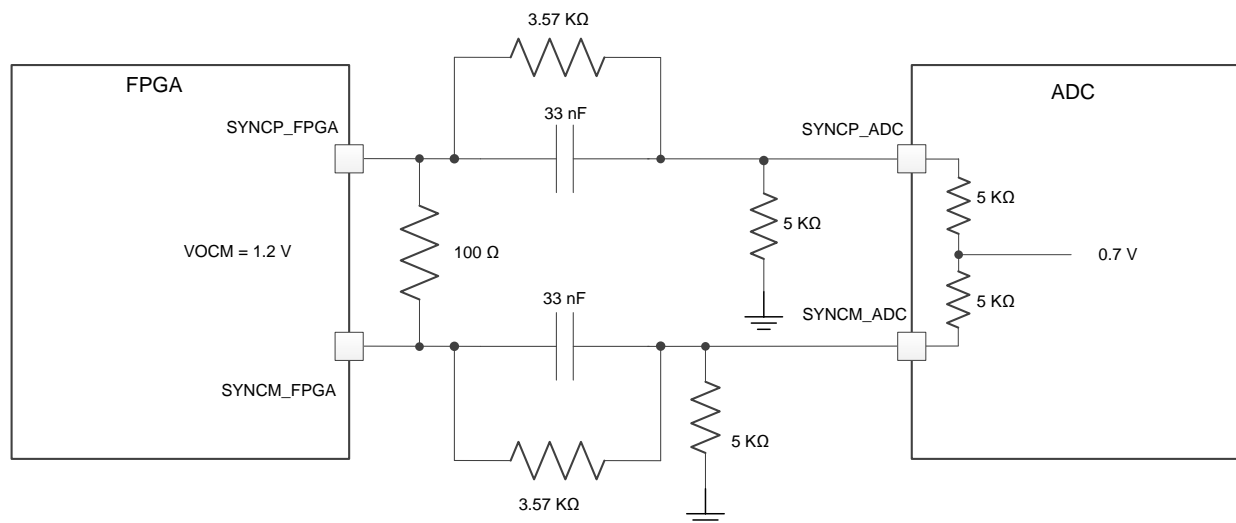

图 82. AC-Coupling Scheme for SYSREF (do not use for SYNC~)



图 83. Transient of SYSREF With AC-Coupling

The 50-kΩ and 30-kΩ external resistors along with the two 5-kΩ resistors internal to the ADC form a voltage divider circuit to generate a negative differential offset at the ADC SYSREF input when SYSREF is low. A high-going pulse on the SYSREF_SRC signal passes through the ac-coupling capacitor. The ac-coupling capacitor and the resistors form a high-pass filter and cause the SYSREF_ADC signal to droop towards their quiescent values over time (denoted by the dotted lines in 图 83). However, if the high width of SYSREF is much lower than the time constant of the filter, the circuit is able to pass the pulse properly.

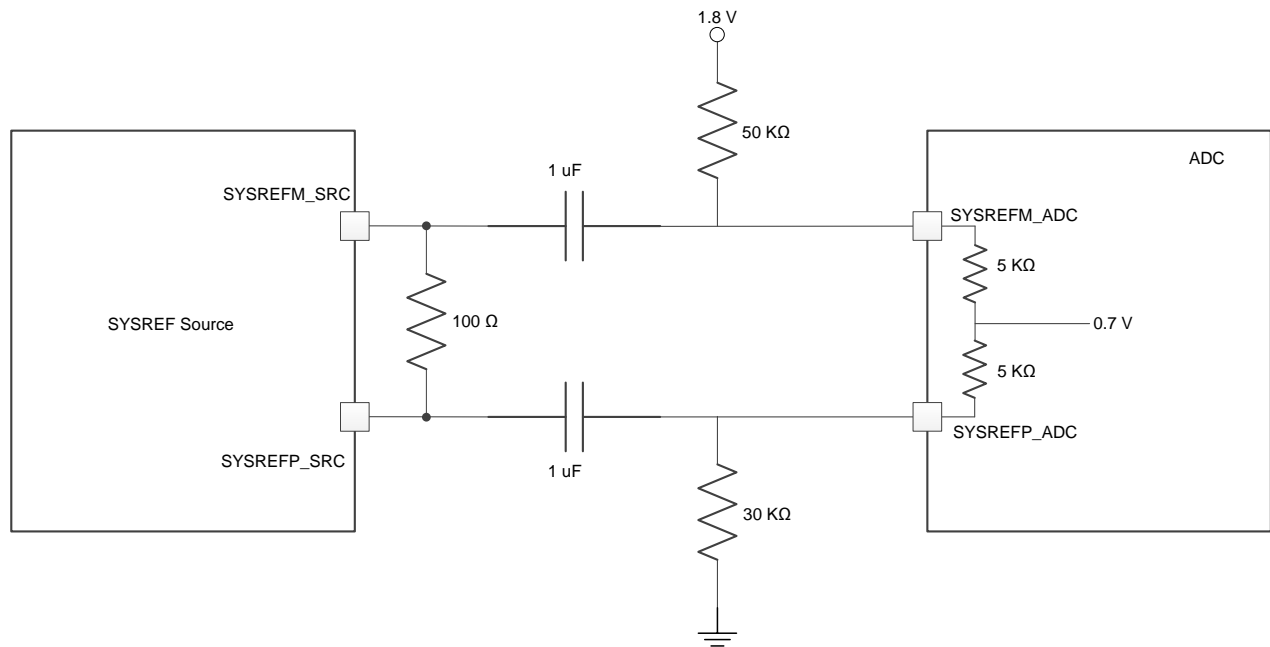
The SYNC~ and SYSREF signals also can be driven using single-ended LVCMOS levels, which can be done by driving the P side with the LVCMOS level and connecting the M side to ground as shown in 图 84. When driven in this manner, the internal 5-kΩ resistor (connecting the P and M pins to the 0.7-V node) is disconnected from the pins.

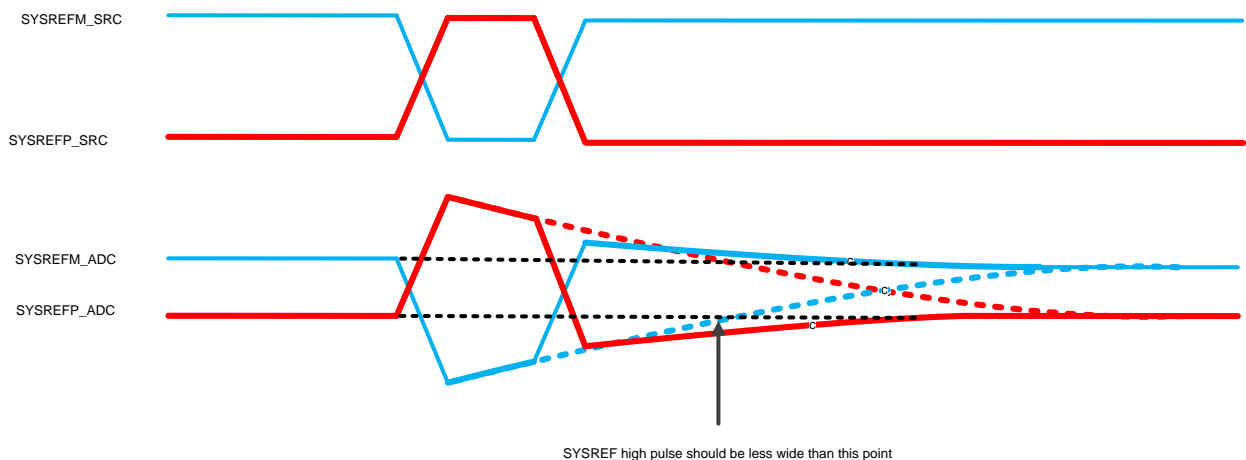

图 84. Single-Ended Driving Circuit for SYNC~ and SYSREF

8.3.11 Clock Input

The input clock to the device (referred to as the system clock) goes to an input buffer that automatically configures itself either to accept a single-ended clock or a differential clock. The equivalent load on the clock pins in the case of a differential clock input is shown in [图 85](#). For the case of a single-ended clock input, the 5-k Ω resistor is disconnected from the input.

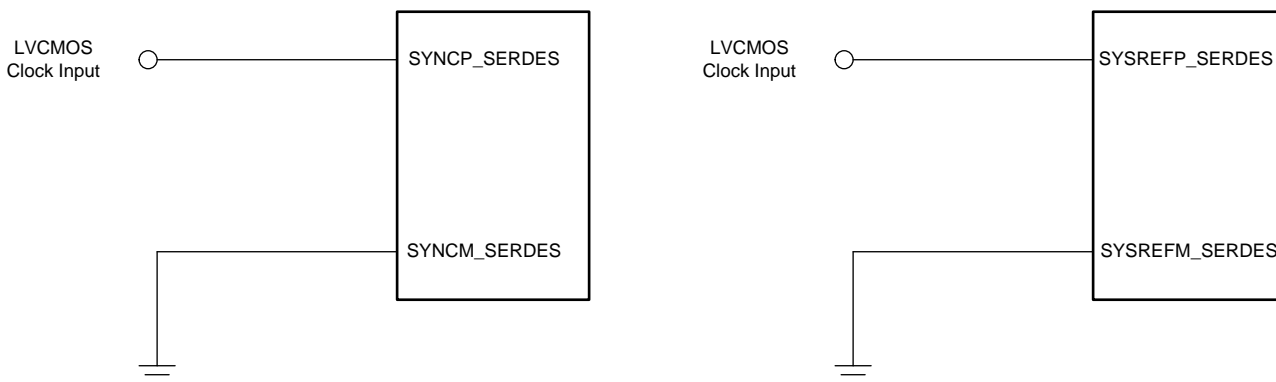

图 85. Internal Clock Buffer for Differential Clock Mode

If the preferred clocking scheme for the device is single-ended, connect the CLKM pin to ground (in other words, short CLKM directly to AVSS, as shown in 图 86). In this case, the auto-detect feature shuts down the internal differential clock buffer and the device automatically goes into a single-ended clock input. Connect the single-ended clock source directly (without decoupling) to the CLKP pin. When using a single-ended clock input, TI recommends using low-jitter, square signals (LVCMOS levels, 1.8-V amplitude) to drive the ADC (refer to technical brief, *Clocking High-Speed Data Converters*, [SLYT075](#) for further details).

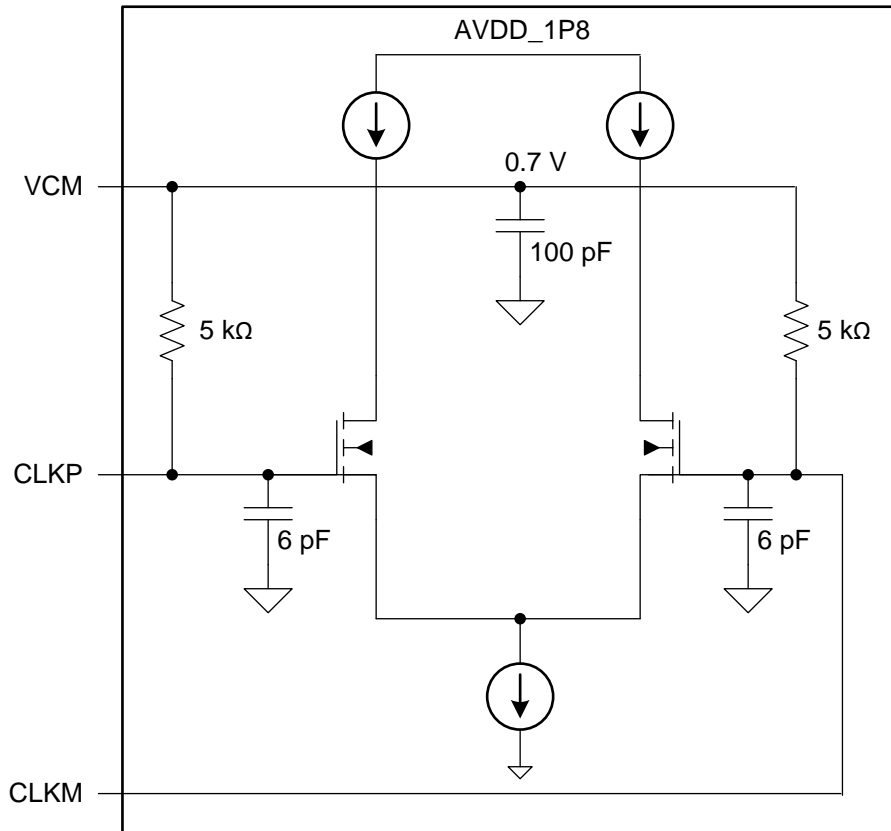

图 86. Single-Ended Clock Driving Circuit

For differential clocks (such as differential sine-wave, LVPECL, LVDS, and so forth), enable the clock amplifier with the connection scheme shown in 图 87. This same scheme applies when the clock is single-ended but the clock amplitude is either small or its edges are not sharp. In this case, connect the input clock signal with a capacitor to CLKP (as in 图 87) and connect CLKM to ground through a capacitor (that is, ac-coupled to AVSS).

If a transformer is used with the secondary coil floating (for instance, to convert from single-ended to differential), the outputs of the transformer can be connected directly to the clock inputs without requiring the 10-nF series capacitors.

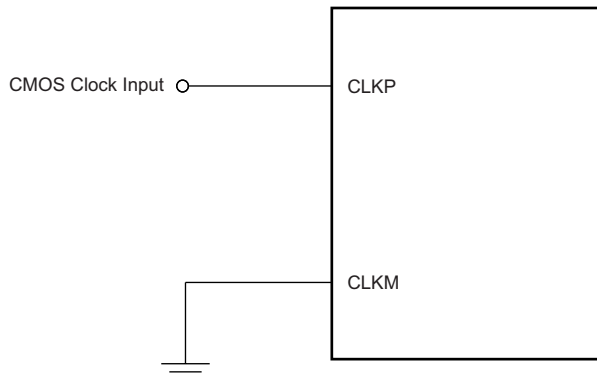

图 87. Differential Clock Driving Circuit

To ensure that the aperture delay and jitter are the same for all channels, the device uses a clock tree network to generate individual sampling clocks for each channel. For all channels, the clock is closely matched from the source point to the sampling circuit of each of the eight internal devices.

The jitter cleaners [CDCM7005](#), [CDCE72010](#), or [LMK048X](#) series are suitable to generate the system clock and enable high performance. [图 88](#) shows a clock distribution network.

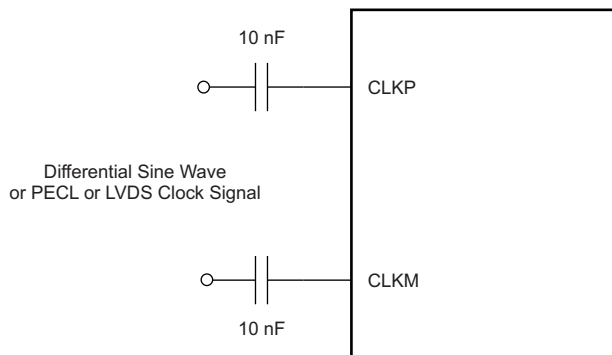

图 88. System Clock Distribution Network

8.3.12 Analog Input and Driving Circuit

8.3.12.1 Signal Input

The analog input to the device can be either ac- or dc-coupled. In ac-coupling, the input common-mode required for device functionality can be forced with the common-mode voltage, generated internally by the device (that comes at the VCM pin) through a resistor, as shown in [图 89](#). The resistor and capacitor values used for coupling determines the high-pass filter corner of the input circuit; thus, these values are chosen with the frequency of interest in mind.

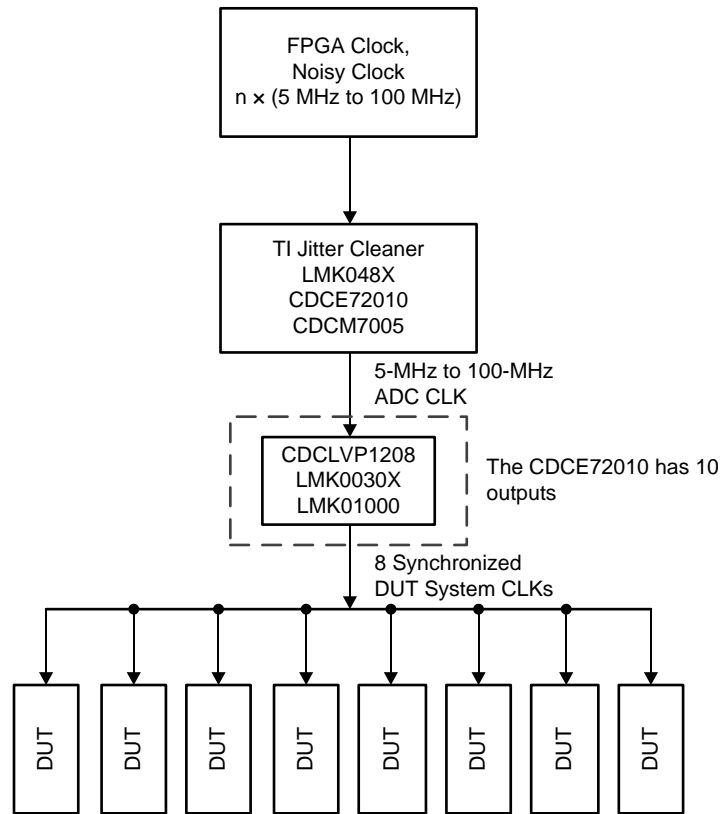

图 89. AC Coupling

When dc-coupling the analog input, the output common-mode voltage of the driver can be set using the VCM output pin as a reference, as shown in [图 90](#).

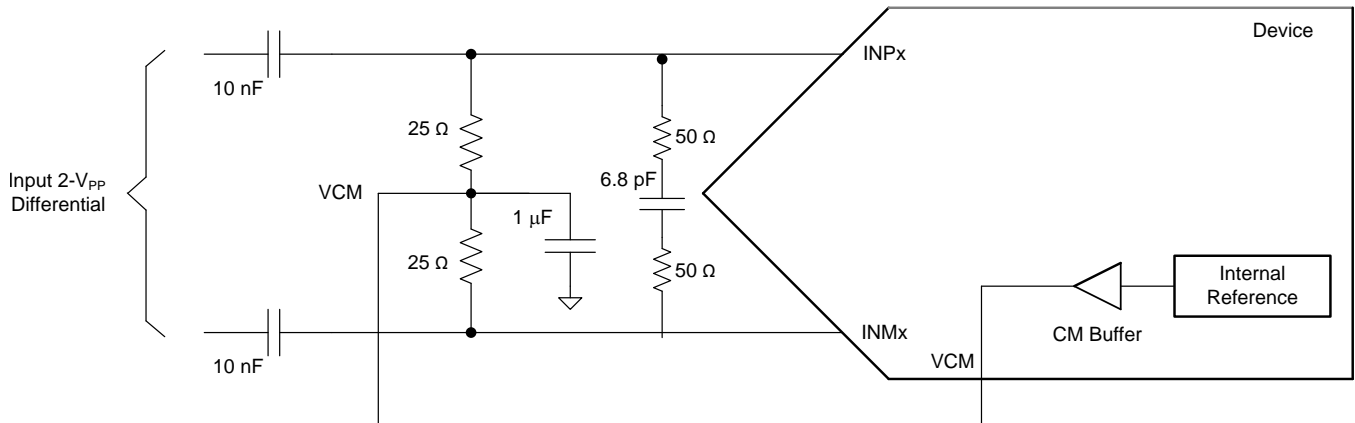

图 90. DC Coupling

Each input interfaces to two sets of identical sampling circuits. The electrical model of the load that each of the sampling networks present is illustrated in [图 91](#). For the sake of simplification, the MOS switches can be considered as ideal switches.

As illustrated in [图 57](#), [图 58](#), and [图 59](#), the scheme of connecting each input sampling circuit to the input pins differs across the three input modes. The time-dependent loading of the input pins therefore is different across the three input modes, and can be determined by referring to [图 57](#), [图 58](#), [图 59](#), and [图 91](#).

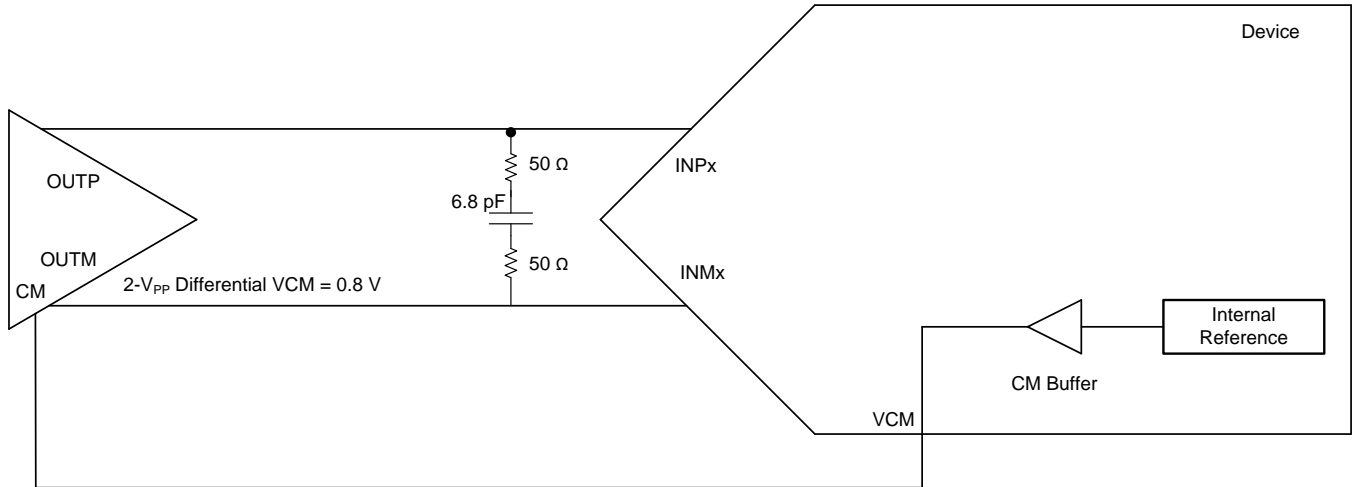

图 91. Analog Input Sampling Network

8.4 Device Functional Modes

8.4.1 Input Modes

The device supports three input modes: a 16-input, a 32-input, and an 8-input mode using the SEL_CH[2:0] register controls. See [表 49](#) for a listing of register bits that select the 8-, 16-, and 32-input modes. Using the same set of 16 ADCs, the three modes can be used to convert 16, 32, or 8 input channels, respectively. The performance of the ADC itself depends on the conversion clock frequency, which has a different relationship to the system clock and sampling rates in each of the three modes. Although the ADCs are common to all three modes, the manner in which the ADCs are used determines unique performance characteristics in each mode. For example, the 8-input mode can have significant interleaving spurs. Additionally, in the 8-input mode, the conversion phases of two adjacent ADCs are offset by one system clock period. The switching operation in one ADC can affect the performance of the adjacent ADC especially at higher input frequencies. For this reason, only 10-bit ADC resolution is supported in the 8-input mode. The restrictions when operating in the different input modes are listed in [表 30](#).

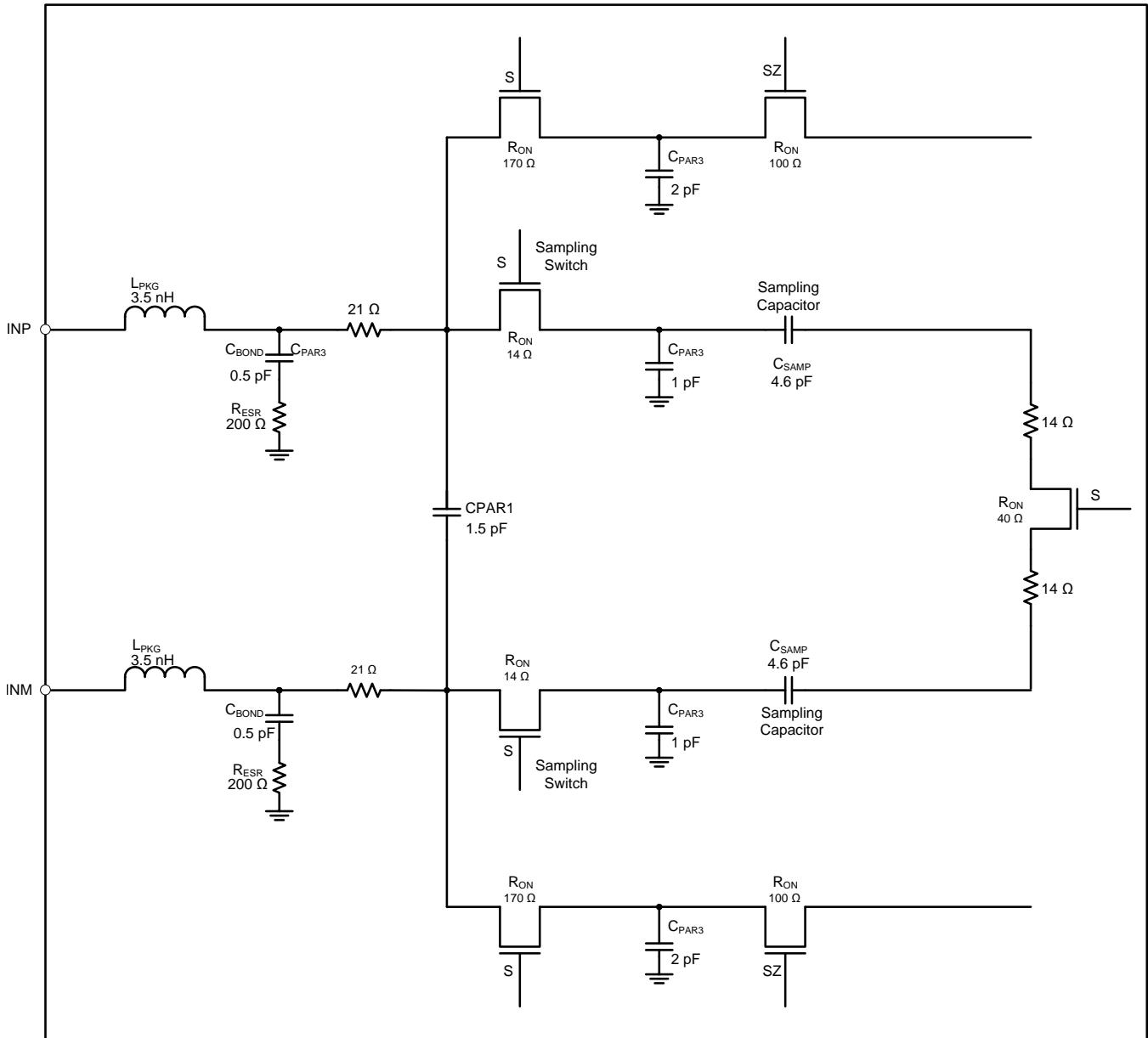
表 30. Modes Supported in 8-, 16-, and 32-Input Modes

| ANALOG INPUT MODE | ADC RESOLUTIONS SUPPORTED (Bits) | LVDS DATA RATE MODES SUPPORTED |
|-------------------|----------------------------------|--------------------------------|
| 16 | 10, 12, 14 | 1X, 2X |
| 32 | 10, 12, 14 | 1X |
| 8 | 10 | 1X, 2X |

8.4.2 ADC Resolution Modes

The ADC resolution can be programmed between 10, 12, and 14 with the ADC_RES register control. The maximum conversion rate of each ADC is determined by the programmed ADC resolution. The restrictions when operating with the different ADC resolutions are listed in [表 31](#).

表 31. Modes Supported in the 10-, 12-, and 14-Bit ADC Resolution Modes

| ADC RESOLUTION (Bits) | ANALOG INPUT MODES SUPPORTED | MAXIMUM CONVERSION CLOCK (f_c , MHz) |
|-----------------------|------------------------------|---|
| 10 | 16, 8, 32 | 100 |
| 12 | 16, 32 | 80 |
| 14 | 16, 32 | 65 |

8.4.3 LVDS and JESD Interface Modes

By default, the LVDS interface is enabled. To disable the LVDS interface, set DIS_LVDS to 1.

To enable the JESD204B interface, set EN_JESD to 1. The JESD204B interface is supported only in 16-input and 32-input modes.

8.4.4 LVDS Serialization and Output Data Rate Modes

The serialization factor of the LVDS interface can be set to 10, 12, 14, or 16 using the SER_DATA_RATE register. Additionally, the density of output data payload can be set to 1X or 2X mode by using the LVDS_RATE_2X register bits. The maximum data rate (in bits per sec) of the LVDS interface is limited. Depending on the input mode, serialization factor, and output data rate mode, the LVDS interface speed restriction may impose additional constraints on the maximum sampling rate achievable.

8.4.5 Power Modes

The ADS52J90 can be configured via SPI or pin settings to a global power-down mode and via pin settings to a fast power-down (standby mode). During these two modes (global and standby power-down), different internal functions stay powered up, resulting in different power consumption and wake-up times.

In standby mode, all LVDS data lanes are powered down. The bit clock and frame clock lanes remain enabled to save time to sync again on the receiver side. However, in global power-down mode all lanes are powered down and thus this mode requires more time to wake-up because the bit clock and frame clock lanes must sync again with the receiver device.

The device consists of the following key blocks:

- Band-gap circuit,
- Serial interface,
- Reference voltage and current generator,
- ADC analog block that performs a sampling and conversion,
- ADC digital block that includes all the digital post processing blocks (such as the offset, gain, digital HPF, and so forth),
- LVDS data serializer and buffer that converts the ADC parallel data to a serial stream,
- LVDS frame and clock serializer and buffer, and
- PLL (phase-locked loop) that generates a high-frequency clock for both the ADC and serializer.

Of all these blocks, only the band-gap and serial interface block are not powered down using the power-down pins or bits. 表 32 lists which blocks in the ADC are powered down using different pins and bits.

表 32. Power-Down Modes Description for the ADC

| NAME | TYPE (Pin or Register) | ADC ANALOG | ADC DIGITAL | LVDS DATA SERIALIZER, BUFFER | LVDS FRAME AND CLOCK SERIALIZER, BUFFER | REFERENCE + ADC CLOCK BUFFER | PLL | CHANNEL |
|--------------|------------------------|--------------------|-------------|------------------------------|---|------------------------------|-----|--------------------|
| PDN_GBL | Pin | Yes ⁽¹⁾ | Yes | Yes | Yes | Yes | Yes | All ⁽²⁾ |
| GLOBAL_PDN | Register | Yes | Yes | Yes | Yes | Yes | Yes | All |
| PDN_FAST | Pin | Yes | Yes | Yes | No | No | No | All |
| DIS_LVDS | Register | No | No | Yes | Yes | No | No | All |
| PDN_ANA_ADCx | Register | Yes | No | No | No | No | No | Individual |
| PDN_DIG_ADCx | Register | No | Yes | No | No | No | No | Individual |
| PDN_LVDSx | Register | No | No | Yes | No | No | No | Individual |

(1) Yes = powered down. No = active.

(2) All = all channels are powered down. Individual = only a single channel is powered down, depending upon the corresponding bit.

8.4.6 LVDS Test Pattern Mode

The ADC data coming out of the LVDS outputs can be replaced by different kinds of test patterns. Note that the test patterns replace the data streaming out of the ADCs (more specifically, the DIGRES1 signal). Therefore, in 16-, 8-, and 32-channel input modes, the pattern that occurs on a per-channel basis can be different for some test patterns. The different test patterns are described in [表 33](#).

表 33. Description of LVDS Test Patterns

| TEST PATTERN MODE | PROGRAMMING THE MODE | | TEST PATTERNS REPLACE ⁽¹⁾ |
|-------------------|--|---|---|
| | THE SAME PATTERN MUST BE COMMON TO ALL DATA LINES | THE PATTERN IS SELECTIVELY REQUIRED ON ONE OR MORE DATA LINE | |
| All 0s | Set the mode using PAT_MODES[2:0] | Set PAT_SELECT_IND = 1. To output the pattern on the DOUTx line, select PAT_LVDSx[2:0] | Zeros in all bits (00000000000000) of DIGRESx |
| All 1s | Set the mode using PAT_MODES[2:0] | Set PAT_SELECT_IND = 1. To output the pattern on the DOUTx line, select PAT_LVDSx[2:0] | Ones in all bits (11111111111111) of DIGRESx |
| Deskew | Set the mode using PAT_MODES[2:0] | Set PAT_SELECT_IND = 1. To output the pattern on the DOUTx line, select PAT_LVDSx[2:0] | DIGRESx word is replaced by alternate 0s and 1s (01010101010101) |
| Sync | Set the mode using PAT_MODES[2:0] | Set PAT_SELECT_IND = 1. To output the pattern on the DOUTx line, select PAT_LVDSx[2:0] | DIGRESx word is replaced by half 1s and half 0s (11111110000000) |
| Custom | Set the mode using PAT_MODES[2:0]. Set the desired custom pattern using the CUSTOM_PATTERN register control. | Set PAT_SELECT_IND = 1. To output the pattern on the DOUTx line, select PAT_LVDSx[2:0] | The word written in the CUSTOM_PATTERN control (taken from the MSB side) replaces DIGRESx. (For instance, CUSTOM_PATTERN = 1100101101011100 and DIGRESx = 11001011010111 when the serialization factor is 14.) |
| Ramp | Set the mode using PAT_MODES[2:0] | Set PAT_SELECT_IND = 1. To output the pattern on the DOUTx line, select PAT_LVDSx[2:0] | The ADCOUTx word (not the DIGRESx word) is replaced by a word that increments by 1 LSB every conversion clock starting at negative full-scale, increments until positive full-scale, and wraps back to negative full-scale. |
| Toggle | Set the mode using PAT_MODES[2:0] | Set PAT_SELECT_IND = 1. To output the pattern on the DOUTx line, select PAT_LVDSx[2:0] | The DIGRESx word alternates between two words that are all 1s and all 0s. At each setting of the toggle pattern, the start word can either be all 0s or all 1s. (Alternate between 11111111111111 and 00000000000000.) |
| PRBS | Set SEL_PRBS_PAT_GBL = 1. Select either custom or ramp pattern with PAT_MODES[2:0]. Enable PRBS mode using PRBS_EN. Select the desired PRBS mode using PRBS_MODE. Reset the PRBS generator with PRBS_SYNC. | Set PAT_SELECT_IND = 1. Select either custom or ramp pattern with PAT_LVDSx[2:0]. Enable PRBS mode on DOUTx with the PAT_PRBS_LVDSx control. Select the desired PRBS mode using PRBS_MODE. Reset the PRBS generator with PRBS_SYNC. | A 16-bit pattern is generated by a 23-bit (or 9-bit) PRBS pattern generator (taken from the MSB side) and replaces the DIGRESx word. |

(1) Shown for a serialization factor of 14.

All patterns listed in [表 33](#) (except the PRBS pattern) can also be forced on the frame clock output line by using PAT_MODES_FCLK[2:0]. To force a PRBS pattern on the frame clock, use the SEL_PRBS_PAT_FCLK, PRBS_EN, and PAT_MODES_FCLK register controls.

The ramp, toggle, and pseudo-random sequence (PRBS) test patterns can be reset or synchronized by providing a synchronization pulse on the TX_TRIG pin or by setting and resetting a specific register bit.

These test patterns also function as transport layer test patterns for the JESD204B interface.

8.5 Programming

8.5.1 Serial Peripheral Interface (SPI) Operation

This section discusses the read and write operations of the SPI interface.

8.5.1.1 Serial Register Write Description

Several different modes can be programmed with the serial peripheral interface (SPI). This interface is formed by the SEN (serial interface enable), SCLK (serial interface clock), SDIN (serial interface data), and RESET pins. The SCLK, SDIN, and RESET pins have a 20-k Ω pulldown resistor to ground. SEN has a 20-k Ω pullup resistor to supply. Serially shifting bits into the device is enabled when SEN is low. SDIN serial data are latched at every SCLK rising edge when SEN is active (low). SDIN serial data are loaded into the register at every 24th SCLK rising edge when SEN is low. If the word length exceeds a multiple of 24 bits, the excess bits are ignored. Data can be loaded in multiples of 24-bit words within a single active SEN pulse (an internal counter counts the number of 24 clock groups after the SEN falling edge). Data is divided into two main portions: the register address (8 bits) and data (16 bits). [Figure 92](#) shows the timing diagram for serial interface write operation.



图 92. Serial Interface Timing

Programming (接下页)

8.5.1.2 Register Readout

The device includes an option where the contents of the internal registers can be read back. This readback can be useful as a diagnostic test to verify the serial interface communication between the external controller and AFE. First, the REG_READ_EN bit must be set to 1. Then, initiate a serial interface cycle specifying the address of the register (A[7:0]) whose content must be read. The data bits are *don't care*. The device outputs the contents (D[15:0]) of the selected register on the SDOUT pin. For lower-speed SCLKs, SDOUT can be latched on the SCLK rising edge. For higher-speed SCLKs, latching SDOUT at the next SCLK falling edge is preferable. The read operation timing diagram is shown in 图 93. In readout mode, the REG_READ_EN bit can be accessed with SDIN, SCLK, and SEN. To enable serial register writes, set the REG_READ_EN bit back to 0.

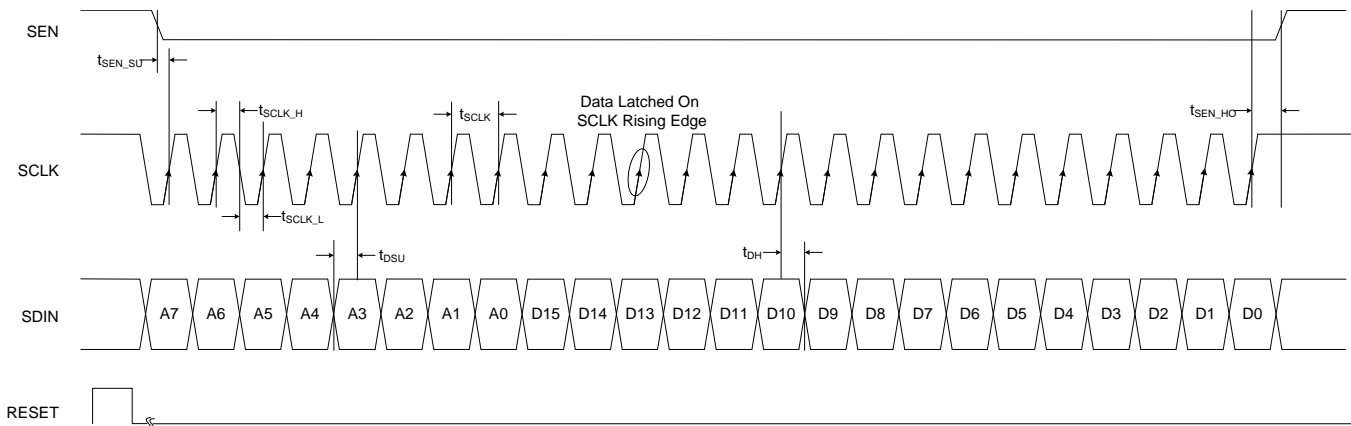

图 93. Serial Interface Register, Read Operation

The device SDOUT buffer is 3-stated and is only enabled when the REG_READ_EN bit is enabled. SDOUT pins from multiple devices can therefore be tied together without any pullup resistors. The SN74AUP1T04 level shifter can be used to convert 1.8-V logic to 2.5-V or 3.3-V logic, if necessary.

9 Application and Implementation

注

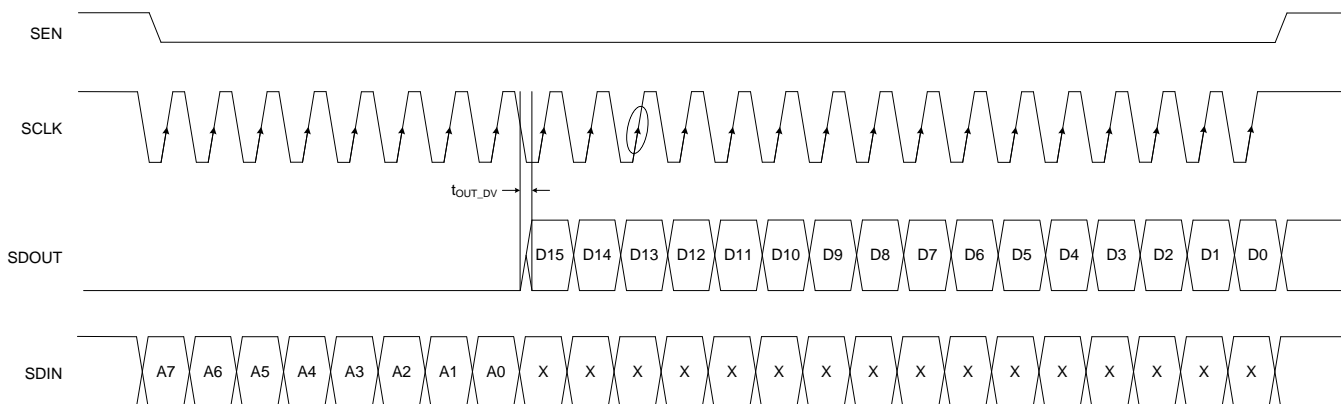
Information in the following applications sections is not part of the TI component specification, and TI does not warrant its accuracy or completeness. TI's customers are responsible for determining suitability of components for their purposes. Customers should validate and test their design implementation to confirm system functionality.

9.1 Application Information

The ADS52J90 supports multiple levels of channel integration (8, 16, and 32) with high sampling rates achievable for each channel. The ADS52J90 also has options to synchronize the clocking and LVDS interface of multiple devices. These features, combined with the excellent ADC performance and low power, make the ADS52J90 an excellent choice for applications involving high channel counts. Such applications include ultrasound imaging systems, sonar imaging equipment, and radar.

9.2 Typical Application

An illustration of a system with a channel count of 64 is shown in 图 94. In 图 94, the output interface is selected as the LVDS interface. Four ADS52J90 devices, each operating in 16-input mode, are connected to a single FPGA that aggregates the data from all ADCs for further data processing and storage.



图 94. Application Schematic: 64-Channel Medical Ultrasound Receiver Using the ADS52J90

Typical Application (接下页)

9.2.1 Design Requirements

Typical requirements of a medical ultrasound receiver system are listed in 表 34.

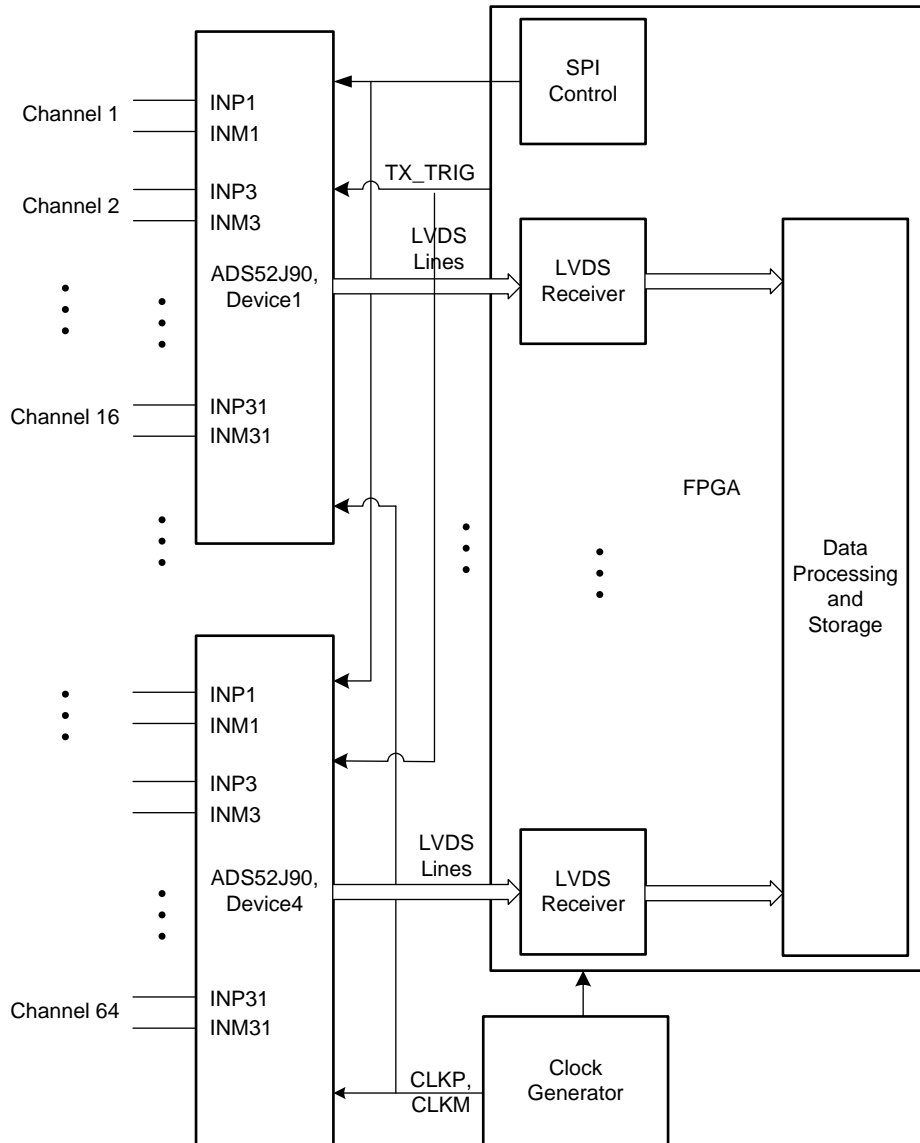
表 34. Requirements of a Typical Medical Ultrasound Receiver

| DESIGN PARAMETER | EXAMPLE VALUES |
|--------------------------------|--------------------------|
| Signal center frequency | 5 MHz-15 MHz |
| Signal bandwidth | 2 MHz |
| Maximum input signal amplitude | 100 mV _{PP} |
| Transducer noise level | 1 nV/ $\sqrt{\text{Hz}}$ |
| Total harmonic distortion | 40 dBc |

The ultrasound system typically has an LNA and a time-dependent gain block at the front-end before the ADC. In an ultrasound receiver, the signal level keeps reducing as a function of time and the role of the front-end blocks is to gain up the signal level without adding too much additional noise. The gain of the front-end can be adjusted so that the input signal to the ADC always remains within its full-scale range.

A sampling rate of approximately 40 MHz to 50 MHz is usually sufficient for such an application. Thus the ADS52J90 can be operated in 16-input mode. Furthermore, the resolution can be set to 14 bits to maximize the SNR of the device. A higher sampling rate ADC results in a lower noise density in the signal band of interest. For example, an ADC with a 2-V_{PP} input operating at 50 MSPS with an SNR of 73 dBFS has a noise level of approximately 35 nV/ $\sqrt{\text{Hz}}$ referred to the input of the ADC. If the front-end has a gain of 40 dB, the ADC noise referred to the input of the front-end is then 0.35 nV/ $\sqrt{\text{Hz}}$, which in this case is lower than the transducer noise level.

9.2.2 Detailed Design Procedure

The design considerations when designing with the 16-, 32-, and 8-input modes are described in the following sections.

9.2.2.1 Designing with the 16-Input Mode

Mapping of the analog inputs to the LVDS outputs is shown in 表 35 for a case corresponding to a 16-input mode and a 1X data rate.

表 35. Mapping of Analog Inputs to LVDS Outputs (16-Input Mode, 1X Data Rate)

| ANALOG INPUT SIGNAL | CONNECTION TO ANALOG INPUT PINS | SAMPLING INSTANT | ADC WORD | SERIAL_OUT (Over Two Frames) | LVDS OUTPUTS ON DOUT PINS |
|---------------------|---------------------------------|------------------|-----------|--|---------------------------|
| AIN1 | IN1 | t_1 | ADCOUT1o | Frame 1: ADCOUT1o Frame 2: ADCOUT1e | DOUT1 |
| | | t_2 | ADCOUT1e | | |
| AIN2 | IN3 | t_1 | ADCOUT2o | Frame 1: ADCOUT2o Frame 2: ADCOUT2e | DOUT2 |
| | | t_2 | ADCOUT2e | | |
| AIN3 | IN5 | t_1 | ADCOUT3o | Frame 1: ADCOUT3o Frame 2: ADCOUT3e | DOUT3 |
| | | t_2 | ADCOUT3e | | |
| AIN4 | IN7 | t_1 | ADCOUT4o | Frame 1: ADCOUT4o Frame 2: ADCOUT4e | DOUT4 |
| | | t_2 | ADCOUT4e | | |
| AIN5 | IN9 | t_1 | ADCOUT5o | Frame 1: ADCOUT5o Frame 2: ADCOUT5e | DOUT5 |
| | | t_2 | ADCOUT5e | | |
| AIN6 | IN11 | t_1 | ADCOUT6o | Frame 1: ADCOUT6o Frame 2: ADCOUT6e | DOUT6 |
| | | t_2 | ADCOUT6e | | |
| AIN7 | IN13 | t_1 | ADCOUT7o | Frame 1: ADCOUT7o Frame 2: ADCOUT7e | DOUT7 |
| | | t_2 | ADCOUT7e | | |
| AIN8 | IN15 | t_1 | ADCOUT8o | Frame 1: ADCOUT8o Frame 2: ADCOUT8e | DOUT8 |
| | | t_2 | ADCOUT8e | | |
| AIN9 | IN17 | t_1 | ADCOUT9o | Frame 1: ADCOUT9o Frame 2: ADCOUT9e | DOUT9 |
| | | t_2 | ADCOUT9e | | |
| AIN10 | IN19 | t_1 | ADCOUT10o | Frame 1: ADCOUT10o Frame 2: ADCOUT10e | DOUT10 |
| | | t_2 | ADCOUT10e | | |
| AIN11 | IN21 | t_1 | ADCOUT11o | Frame 1: ADCOUT11o Frame 2: ADCOUT11e | DOUT11 |
| | | t_2 | ADCOUT11e | | |
| AIN12 | IN23 | t_1 | ADCOUT12o | Frame 1: ADCOUT12o Frame 2: ADCOUT12e | DOUT12 |
| | | t_2 | ADCOUT12e | | |
| AIN13 | IN25 | t_1 | ADCOUT13o | Frame 1: ADCOUT13o Frame 2: ADCOUT13e | DOUT13 |
| | | t_2 | ADCOUT13e | | |
| AIN14 | IN27 | t_1 | ADCOUT14o | Frame 1: ADCOUT14o Frame 2: ADCOUT14e | DOUT14 |
| | | t_2 | ADCOUT14e | | |
| AIN15 | IN29 | t_1 | ADCOUT15o | Frame 1: ADCOUT15o Frame 2: ADCOUT15e | DOUT15 |
| | | t_2 | ADCOUT15e | | |
| AIN16 | IN31 | t_1 | ADCOUT16o | Frame 1: ADCOUT16o Frame 2: ADCOUT16e | DOUT16 |
| | | t_2 | ADCOUT16e | | |

Mapping of the analog inputs to the LVDS outputs is shown in 表 36 for a case corresponding to a 16-input mode and a 2X data rate.

表 36. Mapping of Analog Inputs to LVDS Outputs (16-Input Mode, 2X Data Rate)

| ANALOG INPUT SIGNAL | CONNECTION TO ANALOG INPUT PINS | SAMPLING INSTANT | ADC WORD | SERIAL_OUT (Over Two Frames) | LVDS OUTPUTS ON DOUT PINS |
|---------------------|---------------------------------|------------------|-----------|--|---------------------------|
| AIN1 | IN1 | t ₁ | ADCOUT1o | Frame 1: ADCOUT1o, ADCOUT2o Frame 2: ADCOUT1e, ADCOUT2e | DOUT1 |
| | | t ₂ | ADCOUT1e | | |
| AIN2 | IN3 | t ₁ | ADCOUT2o | | |
| | | t ₂ | ADCOUT2e | | |
| AIN3 | IN5 | t ₁ | ADCOUT3o | Frame 1: ADCOUT3o, ADCOUT4o Frame 2: ADCOUT3e, ADCOUT4e | DOUT2 |
| | | t ₂ | ADCOUT3e | | |
| AIN4 | IN7 | t ₁ | ADCOUT4o | | |
| | | t ₂ | ADCOUT4e | | |
| AIN5 | IN9 | t ₁ | ADCOUT5o | Frame 1: ADCOUT5o, ADCOUT6o Frame 2: ADCOUT5e, ADCOUT6e | DOUT3 |
| | | t ₂ | ADCOUT5e | | |
| AIN6 | IN11 | t ₁ | ADCOUT6o | | |
| | | t ₂ | ADCOUT6e | | |
| AIN7 | IN13 | t ₁ | ADCOUT7o | Frame 1: ADCOUT7o, ADCOUT8o Frame 2: ADCOUT7e, ADCOUT8e | DOUT4 |
| | | t ₂ | ADCOUT7e | | |
| AIN8 | IN15 | t ₁ | ADCOUT8o | | |
| | | t ₂ | ADCOUT8e | | |
| AIN9 | IN17 | t ₁ | ADCOUT9o | Frame 1: ADCOUT9o, ADCOUT10o Frame 2: ADCOUT9e, ADCOUT10e | DOUT9 |
| | | t ₂ | ADCOUT9e | | |
| AIN10 | IN19 | t ₁ | ADCOUT10o | | |
| | | t ₂ | ADCOUT10e | | |
| AIN11 | IN21 | t ₁ | ADCOUT11o | Frame 1: ADCOUT11o, ADCOUT12o Frame 2: ADCOUT11e, ADCOUT12e | DOUT10 |
| | | t ₂ | ADCOUT11e | | |
| AIN12 | IN23 | t ₁ | ADCOUT12o | | |
| | | t ₂ | ADCOUT12e | | |
| AIN13 | IN25 | t ₁ | ADCOUT13o | Frame 1: ADCOUT13o, ADCOUT14 Frame 2: ADCOUT13e, ADCOUT14e | DOUT11 |
| | | t ₂ | ADCOUT13e | | |
| AIN14 | IN27 | t ₁ | ADCOUT14o | | |
| | | t ₂ | ADCOUT14e | | |
| AIN15 | IN29 | t ₁ | ADCOUT15o | Frame 1: ADCOUT15o, ADCOUT16o Frame 2: ADCOUT15e, ADCOUT16e | DOUT12 |
| | | t ₂ | ADCOUT15e | | |
| AIN16 | IN31 | t ₁ | ADCOUT16o | | |
| | | t ₂ | ADCOUT16e | | |

表 35 and 表 36 illustrate that the ADCs convert the odd numbered input when operating in the 16-input mode. Each ADC can be set to convert the following even numbered input using the register control IN_CH_ADCx. The performance of the ADC may slightly degrade when IN_CH_ADCx is set to 1.

In 16-input mode, there is a one-to-one mapping between the inputs and the ADCs. The register map relative to the ADCs can therefore be mapped to the 16 channels, as shown in [表 37](#).

表 37. Reinterpretation of the Register Map in 16-Input Mode

| REGISTER MAP NOTATION | MAPPING TO CHANNELS IN 16-INPUT MODE | EXAMPLE |
|--|--------------------------------------|---|
| GAIN_ADCx _o , GAIN_ADCx _e | GAIN_CHANNELx | GAIN_CHANNEL1 = GAIN_ADC1 _o (same for GAIN_ADC1 _e) (Set odd and even gains of the same ADC to the same setting) |
| OFFSET_ADCx _o , OFFSET_ADCx _e | OFFSET_CHANNELx | OFFSET_CHANNEL1 = OFFSET_ADC1 _o (same for OFFSET_ADC1 _e) (Set odd and even offsets of the same ADC to the same setting) |
| PDN_DIG_ADCx | PDN_DIG_CHANNELx | PDN_DIG_CHANNEL1 = PDN_DIG_ADC1 |
| PDN_ANA_ADCx | PDN_ANA_CHANNELx | PDN_ANA_CHANNEL1 = PDN_ANA_ADC1 |
| DIG_HPF_EN_ADCx | Mapped to 4 channels | DIG_HPF_EN_CHANNEL1-4 = DIG_HPF_EN_ADC1-4 Common setting for 4 ADCs maps to common setting for 4 channels |
| HPF_CORNER_ADCx | Mapped to 4 channels | HPF_CORNER_CHANNEL1-4 = HPF_CORNER_ADC1-4 Common setting for 4 ADCs maps to common setting for 4 channels |

9.2.2.2 Designing with the 32-Input Mode

Mapping of the analog inputs to the LVDS outputs is shown in [表 38](#) for a case corresponding to a 32-input mode and a 1X data rate.

表 38. Mapping of Analog Inputs to LVDS Outputs (32-Input Mode, 1X Data Rate)

| ANALOG INPUT SIGNAL | CONNECTION TO ANALOG INPUT PINS | SAMPLING INSTANT | ADC WORD | SERIAL_OUT (Over One Frame) | LVDS OUTPUTS ON DOUT PINS |
|---------------------|---------------------------------|------------------|-----------------------|--|---------------------------|
| AIN1 | IN1 | t ₁ | ADCOUT1 _o | ADCOUT1 _o , ADCOUT1 _e | DOUT1 |
| AIN2 | IN2 | t ₂ | ADCOUT1 _e | | |
| AIN3 | IN3 | t ₁ | ADCOUT2 _o | ADCOUT2 _o , ADCOUT2 _e | DOUT2 |
| AIN4 | IN4 | t ₂ | ADCOUT2 _e | | |
| AIN5 | IN5 | t ₁ | ADCOUT3 _o | ADCOUT3 _o , ADCOUT3 _e | DOUT3 |
| AIN6 | IN6 | t ₂ | ADCOUT3 _e | | |
| AIN7 | IN7 | t ₁ | ADCOUT4 _o | ADCOUT4 _o , ADCOUT4 _e | DOUT4 |
| AIN8 | IN8 | t ₂ | ADCOUT4 _e | | |
| AIN9 | IN9 | t ₁ | ADCOUT5 _o | ADCOUT5 _o , ADCOUT5 _e | DOUT5 |
| AIN10 | IN10 | t ₂ | ADCOUT5 _e | | |
| AIN11 | IN11 | t ₁ | ADCOUT6 _o | ADCOUT6 _o , ADCOUT6 _e | DOUT6 |
| AIN12 | IN12 | t ₂ | ADCOUT6 _e | | |
| AIN13 | IN13 | t ₁ | ADCOUT7 _o | ADCOUT7 _o , ADCOUT7 _e | DOUT7 |
| AIN14 | IN14 | t ₂ | ADCOUT7 _e | | |
| AIN15 | IN15 | t ₁ | ADCOUT8 _o | ADCOUT8 _o , ADCOUT8 _e | DOUT8 |
| AIN16 | IN16 | t ₂ | ADCOUT8 _e | | |
| AIN17 | IN17 | t ₁ | ADCOUT9 _o | ADCOUT9 _o , ADCOUT9 _e | DOUT9 |
| AIN18 | IN18 | t ₂ | ADCOUT9 _e | | |
| AIN19 | IN19 | t ₁ | ADCOUT10 _o | ADCOUT10 _o , ADCOUT10 _e | DOUT10 |
| AIN20 | IN20 | t ₂ | ADCOUT10 _e | | |
| AIN21 | IN21 | t ₁ | ADCOUT11 _o | ADCOUT11 _o , ADCOUT11 _e | DOUT11 |
| AIN22 | IN22 | t ₂ | ADCOUT11 _e | | |
| AIN23 | IN23 | t ₁ | ADCOUT12 _o | ADCOUT12 _o , ADCOUT12 _e | DOUT12 |
| AIN24 | IN24 | t ₂ | ADCOUT12 _e | | |
| AIN25 | IN25 | t ₁ | ADCOUT13 _o | ADCOUT13 _o , ADCOUT13 _e | DOUT13 |
| AIN26 | IN26 | t ₂ | ADCOUT13 _e | | |

表 38. Mapping of Analog Inputs to LVDS Outputs (32-Input Mode, 1X Data Rate) (接下页)

| ANALOG INPUT SIGNAL | CONNECTION TO ANALOG INPUT PINS | SAMPLING INSTANT | ADC WORD | SERIAL_OUT (Over One Frame) | LVDS OUTPUTS ON DOUT PINS |
|---------------------|---------------------------------|------------------|-----------|-----------------------------|---------------------------|
| AIN27 | IN27 | t_1 | ADCOUT14o | ADCOUT14o, ADCOUT14e | DOUT14 |
| AIN28 | IN28 | t_2 | ADCOUT14e | | |
| AIN29 | IN29 | t_1 | ADCOUT15o | ADCOUT15o, ADCOUT15e | DOUT15 |
| AIN30 | IN30 | t_2 | ADCOUT15e | | |
| AIN31 | IN31 | t_1 | ADCOUT16o | ADCOUT16o, ADCOUT16e | DOUT16 |
| AIN32 | IN32 | t_2 | ADCOUT16e | | |

Note that 2X data rate mode is not supported in 32-input mode. In 32-input mode, only one ADC is used to convert two inputs.

The odd numbered inputs correspond to the odd sample from the ADC, and the even numbered inputs correspond to the even sample from the ADC. The register map relative to the ADCs can therefore be mapped to the 32 channels, as shown in [表 39](#).

表 39. Reinterpretation of Register Map in 32-Input Mode

| REGISTER MAP NOTATION | MAPPING TO CHANNELS IN 16-INPUT MODE | EXAMPLE |
|-----------------------|--------------------------------------|--|
| GAIN_ADCxo | GAIN_CHANNEL (odd) | GAIN_CHANNEL1 = GAIN_ADC1o |
| GAIN_ADCxe | GAIN_CHANNEL (even) | GAIN_CHANNEL2 = GAIN_ADC1e |
| OFFSET_ADCXo | OFFSET_CHANNEL (odd) | OFFSET_CHANNEL1 = OFFSET_ADC1o |
| OFFSET_ADCxe | OFFSET_CHANNEL (even) | OFFSET_CHANNEL2 = OFFSET_ADC1e |
| PDN_DIG_ADCx | PDN_DIG_CHANNEL (odd and even) | PDN_DIG_CHANNEL1 = PDN_DIG_CHANNEL2 = PDN_DIG_ADC1 |
| PDN_ANA_ADCx | PDN_ANA_CHANNEL (odd and even) | PDN_ANA_CHANNEL1 = PDN_ANA_CHANNEL2 = PDN_ANA_ADC1 |
| DIG_HPF_EN_ADCx | Mapped to 8 channels | DIG_HPF_EN_CHANNEL1-8 = DIG_HPF_EN_ADC1-4 Common setting for 4 ADCs mapped to common setting for 8 channels |
| HPF_CORNER_ADCx | Mapped to 8 channels | HPF_CORNER_CHANNEL1-8 = HPF_CORNER_ADC1-4 Common setting for 4 ADCs mapped to common setting for 8 channels |

9.2.2.3 Designing with the 8-Input Mode

Mapping of the analog inputs to the LVDS outputs is shown in 表 40 for a case corresponding to an 8-input mode and a 1X data rate.

表 40. Mapping of Analog Inputs to LVDS Outputs (8-Input Mode, 1X Data Rate)

| ANALOG INPUT SIGNAL | CONNECTION TO ANALOG INPUT PINS | SAMPLING INSTANT | ADC WORD | SERIAL_OUT (Over Two Frames) | LVDS OUTPUTS ON DOUT PINS |
|---------------------|------------------------------------|------------------|-----------|--|---------------------------|
| AIN1 | IN1, IN3 (shorted externally) | t_1 | ADCOUT1o | Frame 1: ADCOUT1o Frame 2: ADCOUT1e | DOUT1 |
| | | t_2 | ADCOUT2o | | |
| | | t_3 | ADCOUT1e | Frame 1: ADCOUT2o Frame 2: ADCOUT2e | DOUT2 |
| | | t_4 | ADCOUT2e | | |
| AIN2 | IN5, IN7 (shorted externally) | t_1 | ADCOUT3o | Frame 1: ADCOUT3o Frame 2: ADCOUT3e | DOUT3 |
| | | t_2 | ADCOUT4o | | |
| | | t_3 | ADCOUT3e | Frame 1: ADCOUT4o Frame 2: ADCOUT4e | DOUT4 |
| | | t_4 | ADCOUT4e | | |
| AIN3 | IN9, IN11 (shorted externally) | t_1 | ADCOUT5o | Frame 1: ADCOUT5o Frame 2: ADCOUT5e | DOUT5 |
| | | t_2 | ADCOUT6o | | |
| | | t_3 | ADCOUT5e | Frame 1: ADCOUT6o Frame 2: ADCOUT6e | DOUT6 |
| | | t_4 | ADCOUT6e | | |
| AIN4 | IN13, IN15 (shorted externally) | t_1 | ADCOUT7o | Frame 1: ADCOUT7o Frame 2: ADCOUT7e | DOUT7 |
| | | t_2 | ADCOUT8o | | |
| | | t_3 | ADCOUT7e | Frame 1: ADCOUT8o Frame 2: ADCOUT8e | DOUT8 |
| | | t_4 | ADCOUT8e | | |
| AIN5 | IN17, IN19 (shorted externally) | t_1 | ADCOUT9o | Frame 1: ADCOUT9o Frame 2: ADCOUT9e | DOUT9 |
| | | t_2 | ADCOUT10o | | |
| | | t_3 | ADCOUT9e | Frame 1: ADCOUT10o Frame 2: ADCOUT10e | DOUT10 |
| | | t_4 | ADCOUT10e | | |
| AIN6 | IN21, IN23 (shorted externally) | t_1 | ADCOUT11o | Frame 1: ADCOUT11o Frame 2: ADCOUT11e | DOUT11 |
| | | t_2 | ADCOUT12o | | |
| | | t_3 | ADCOUT11e | Frame 1: ADCOUT12o Frame 2: ADCOUT12e | DOUT12 |
| | | t_4 | ADCOUT12e | | |
| AIN7 | IN25, IN27 (shorted externally) | t_1 | ADCOUT13o | Frame 1: ADCOUT13o Frame 2: ADCOUT13e | DOUT13 |
| | | t_2 | ADCOUT14o | | |
| | | t_3 | ADCOUT13e | Frame 1: ADCOUT14o Frame 2: ADCOUT14e | DOUT14 |
| | | t_4 | ADCOUT14e | | |
| AIN8 | IN29, IN31 (shorted externally) | t_1 | ADCOUT15o | Frame 1: ADCOUT15o Frame 2: ADCOUT15e | DOUT15 |
| | | t_2 | ADCOUT16o | | |
| | | t_3 | ADCOUT15e | Frame 1: ADCOUT16o Frame 2: ADCOUT16e | DOUT16 |
| | | t_4 | ADCOUT16e | | |

Mapping of the analog inputs to the LVDS outputs is shown in 表 41 for a case corresponding to an 8-input mode and a 2X data rate.

表 41. Mapping of Analog Inputs to LVDS Outputs (8-Input Mode, 2X Data Rate)

| ANALOG INPUT SIGNAL | CONNECTION TO ANALOG INPUT PINS | SAMPLING INSTANT | ADC WORD | SERIAL_OUT (Over Two Frames) | LVDS OUTPUTS ON DOUT PINS |
|---------------------|------------------------------------|------------------|-----------|----------------------------------|---------------------------|
| AIN1 | IN1, IN3 (shorted externally) | t ₁ | ADCOUT1o | Frame 1: ADCOUT1o, ADCOUT2o | DOUT1 |
| | | t ₂ | ADCOUT2o | | |
| | | t ₃ | ADCOUT1e | Frame 2: ADCOUT1e, ADCOUT2e | |
| | | t ₄ | ADCOUT2e | | |
| AIN2 | IN5, IN7 (shorted externally) | t ₁ | ADCOUT3o | Frame 1: ADCOUT3o, ADCOUT4o | DOUT2 |
| | | t ₂ | ADCOUT4o | | |
| | | t ₃ | ADCOUT3e | Frame 2: ADCOUT3e, ADCOUT4e | |
| | | t ₄ | ADCOUT4e | | |
| AIN3 | IN9, IN11 (shorted externally) | t ₁ | ADCOUT5o | Frame 1: ADCOUT5o, ADCOUT6o | DOUT3 |
| | | t ₂ | ADCOUT6o | | |
| | | t ₃ | ADCOUT5e | Frame 2: ADCOUT5e, ADCOUT6e | |
| | | t ₄ | ADCOUT6e | | |
| AIN4 | IN13, IN15 (shorted externally) | t ₁ | ADCOUT7o | Frame 1: ADCOUT7o, ADCOUT8o | DOUT4 |
| | | t ₂ | ADCOUT8o | | |
| | | t ₃ | ADCOUT7e | Frame 2: ADCOUT7e, ADCOUT8e | |
| | | t ₄ | ADCOUT8e | | |
| AIN5 | IN17, IN19 (shorted externally) | t ₁ | ADCOUT9o | Frame 1: ADCOUT9o, ADCOUT10o | DOUT9 |
| | | t ₂ | ADCOUT10o | | |
| | | t ₃ | ADCOUT9e | Frame 2: ADCOUT9e, ADCOUT10e | |
| | | t ₄ | ADCOUT10e | | |
| AIN6 | IN21, IN23 (shorted externally) | t ₁ | ADCOUT11o | Frame 1: ADCOUT11o, ADCOUT12o | DOUT10 |
| | | t ₂ | ADCOUT12o | | |
| | | t ₃ | ADCOUT11e | Frame 2: ADCOUT11e, ADCOUT12e | |
| | | t ₄ | ADCOUT12e | | |
| AIN7 | IN25, IN27 (shorted externally) | t ₁ | ADCOUT13o | Frame 1: ADCOUT13o, ADCOUT14 | DOUT11 |
| | | t ₂ | ADCOUT14o | | |
| | | t ₃ | ADCOUT13e | Frame 2: ADCOUT13e, ADCOUT14e | |
| | | t ₄ | ADCOUT14e | | |
| AIN8 | IN29, IN31 (shorted externally) | t ₁ | ADCOUT15o | Frame 1: ADCOUT15o, ADCOUT16o | DOUT12 |
| | | t ₂ | ADCOUT16o | | |
| | | t ₃ | ADCOUT15e | Frame 2: ADCOUT15e, ADCOUT16e | |
| | | t ₄ | ADCOUT16e | | |

In 8-input mode, two neighboring ADCs are used to convert a single input. The register map relative to the ADCs can be mapped to the eight channels, as shown in 表 42.

表 42. Reinterpretation of Register Map in 8-input Mode

| REGISTER MAP NOTATION | MAPPING TO CHANNELS IN 16-INPUT MODE | EXAMPLE |
|---|--------------------------------------|---|
| GAIN_ADCx _o , GAIN_ADCx _e of two adjacent channels | GAIN_CHANNELx | GAIN_CHANNEL1 = GAIN_ADC1 _o (same for GAIN_ADC1 _e , GAIN_ADC2 _o , and GAIN_ADC2 _e) Set odd and even gains of two adjacent ADCs to the same setting. |
| OFFSET_ADCx _o , OFFSET_ADCx _e | OFFSET_CHANNELx | OFFSET_CHANNEL1 = OFFSET_ADC1 _o (same for OFFSET_ADC1 _e , OFFSET_ADC2 _o , and OFFSET_ADC2 _e) Set odd and even offsets of two adjacent ADCs to the same setting. |
| PDN_DIG_ADCx of two adjacent channels | PDN_DIG_CHANNELx | PDN_DIG_CHANNEL1 = PDN_DIG_ADC1 (same for PDN_DIG_ADC2) Set the power-down for two adjacent ADCs to the same setting. |
| PDN_ANA_ADCx of two adjacent channels | PDN_ANA_CHANNELx | PDN_ANA_CHANNEL1 = PDN_ANA_ADC1 (same for PDN_ANA_ADC2) Set the power-down for two adjacent ADCs to the same setting. |
| DIG_HPF_EN_ADCx | Mapped to 2 channels | DIG_HPF_EN_CHANNEL1-2 = DIG_HPF_EN_ADC1-4 Common setting for 4 ADCs mapped to the common setting for 2 channels. |
| HPF_CORNER_ADCx | Mapped to 2 channels | HPF_CORNER_CHANNEL1-2 = HPF_CORNER_ADC1-4 Common setting for 4 ADCs mapped to the common setting for 2 channels. |

9.2.3 Application Curves

This section outlines the trends described in the *Typical Characteristics* section from an application perspective.

图 2 illustrates the FFT with a 5-MHz input signal for 32-input mode with the ADC resolution set to 10 bits. The system clock provided is 100 MSPS and the input is sampled at an effective rate of 50 MSPS, which is the maximum sampling rate for this mode of operation.

图 3 illustrates the FFT with a 5-MHz input signal for 16-input mode with the ADC resolution set to 10 bits. The system clock provided is 100 MSPS and the input is sampled at an effective rate of 100 MSPS, which is the maximum sampling rate for this mode of operation.

图 4 illustrates the FFT with a 5-MHz input signal for 8-input mode with the ADC resolution set to 10 bits. The system clock provided is 200 MSPS and the input is sampled at an effective rate of 200 MSPS, which is the maximum sampling rate for this mode of operation. The increase in sampling rate is achieved through two ADCs converting the same input in an interleaved manner. The interleaving spurs are visible in the FFT. The predominant spur is at the frequencies of $(f_S / 2 \pm f_{IN})$, which appear at 95 MHz. Additional spurs are at the frequencies of $(f_S / 4 \pm f_{IN})$, which appear at 45 MHz and 55 MHz. The magnitude of the spurs is expected to rise when the input frequency is increased. Also, the spur level is sensitive to the matching of the manner in which the two sets of input pins are driven. A spur at $f_S/4$ is also seen. This arises from the offset mismatch between the four sets of sampling circuits used to sample the same input.

图 5 illustrates the FFT with a 5-MHz input signal for 32-input mode with the ADC resolution set to 12 bits. The system clock provided is 80 MSPS and the input is sampled at an effective rate of 40 MSPS, which is the maximum sampling rate for this mode of operation.

图 6 illustrates the FFT with a 5-MHz input signal for 16-input mode with the ADC resolution set to 12 bits. The system clock provided is 80 MSPS and the input is sampled at an effective rate of 80 MSPS, which is the maximum sampling rate for this mode of operation.

图 7 illustrates the FFT with a 5-MHz input signal for 32-input mode with the ADC resolution set to 14 bits. The system clock provided is 65 MSPS and the input is sampled at an effective rate of 32.5 MSPS, which is the maximum sampling rate for this mode of operation.

图 8 illustrates the FFT with a 5-MHz input signal for 16-input mode with the ADC resolution set to 14 bits. The system clock provided is 65 MSPS and the input is sampled at an effective rate of 65 MSPS, which is the maximum sampling rate for this mode of operation. In addition to the harmonics, the spur at the frequency $(f_S / 2 \pm f_{IN})$ also occurs at 27.5 MHz. This spur is caused by the interleaved sampling of the input signal by two physically different sampling circuits of the same ADC.

图 9 illustrates the signal-to-noise ratio (SNR) versus the frequency of the input signal for 32-input mode with the ADC resolution set to 10 bits. SNR is expressed in the dBFS scale where the RMS noise at the ADC output is referred to the full-scale differential voltage of 2 V. The system clock provided is 100 MSPS and the input is sampled at an effective rate of 50 MSPS. SNR is computed by integrating the noise in all FFT bins after excluding the first nine harmonics. SNR is dominated by the quantization noise of the 10-bit conversion.

图 10 illustrates SNR versus the frequency of the input signal for 16-input mode with the ADC resolution set to 10 bits. The system clock provided is 100 MSPS and the input is sampled at an effective rate of 100 MSPS. SNR is computed by integrating the noise in all FFT bins after excluding the first nine harmonics and any interleaving spurs. SNR is dominated by the quantization noise of the 10-bit conversion.

图 11 illustrates SNR versus the frequency of the input signal for 8-input mode with the ADC resolution set to 10 bits. The system clock provided is 200 MSPS and the input is sampled at an effective rate of 200 MSPS. SNR is computed by integrating the noise in all FFT bins after excluding the first nine harmonics and any interleaving spurs at $(f_S / 2 \pm f_{IN})$ and $(f_S / 4 \pm f_{IN})$ as well as additional spurs at $f_S / 2$ and $f_S / 4$. SNR is dominated by the quantization noise of the 10-bit conversion.

图 12 illustrates SNR versus the frequency of the input signal for 32-input mode with the ADC resolution set to 12 bits. The system clock provided is 80 MSPS and the input is sampled at an effective rate of 40 MSPS.

图 13 illustrates SNR versus the frequency of the input signal for 16-input mode with the ADC resolution set to 12 bits. The system clock provided is 80 MSPS and the input is sampled at an effective rate of 80 MSPS.

图 14 illustrates SNR versus the frequency of the input signal for 32-input mode with the ADC resolution set to 14 bits. The system clock provided is 65 MSPS and the input is sampled at an effective rate of 32.5 MSPS. SNR at high input frequencies degrades because of clock jitter.

图 15 illustrates SNR versus the frequency of the input signal for 16-input mode with the ADC resolution set to 14 bits. The system clock provided is 65 MSPS and the input is sampled at an effective rate of 65 MSPS.

图 16 illustrates the amplitude of the third-order harmonic distortion (HD3) of the input signal versus the frequency of the input signal. The unit of dBc indicates that the HD3 amplitude is referred to the amplitude of the input signal, which is set to -1 dBFS. 图 16 is taken for 32-input mode with the ADC resolution set to 10 bits. The system clock provided is 100 MSPS and the input is sampled at an effective rate of 50 MSPS. The device follows a similar trend across the other input modes and resolutions.

图 17 illustrates the amplitude of the second-order harmonic distortion (HD2) of the input signal versus the frequency of the input signal. The unit of dBc indicates that the HD2 amplitude is referred to the amplitude of the input signal, which is set to -1 dBFS. 图 17 is taken for 32-input mode with the ADC resolution set to 10 bits. The system clock provided is 100 MSPS and the input is sampled at an effective rate of 50 MSPS. The device follows a similar trend across the other input modes and resolutions.

图 18 illustrates the total harmonic distortion (THD) versus the frequency of the input signal. The THD parameter includes the RMS amplitude of the first nine harmonics of the fundamental signal. The unit of dBc indicates that THD is referred to the amplitude of the input signal, which is set to -1 dBFS. 图 18 is taken for 32-input mode with the ADC resolution set to 10 bits. The system clock provided is 100 MSPS and the input is sampled at an effective rate of 50 MSPS. The device follows a similar trend across the other input modes and resolutions.

图 19 illustrates the interleaving spur at $(f_S / 2 \pm f_{IN})$ versus the frequency of the input signal. 图 19 is taken for 8-input mode with the ADC resolution set to 10 bits. The system clock is set to 200 MSPS and the input is sampled at an effective rate of 200 MSPS. The interleaving spur at $(f_S / 2 \pm f_{IN})$ is referred to the fundamental amplitude, which is at a level of -1 dBFS. The $(f_S / 2 \pm f_{IN})$ spur comes about because of the interleaved conversion of the same input by two ADCs. As illustrated in 图 19, the interleaving spur gets much worse at higher input frequencies. This degradation results from the fact that when the input frequency is increased, any mismatch in the sampling bandwidths and sampling instants of the two interleaved ADCs leads to a larger phase error between the interleaved conversions.

图 20 illustrates the interleaving spur at $(f_S / 2 \pm f_{IN})$ versus the frequency of the input signal. 图 20 is taken for 16-input mode with the ADC resolution set to 10 bits. The system clock is set to 100 MSPS and the input is sampled at an effective rate of 100 MSPS. The $(f_S / 2 \pm f_{IN})$ spur comes about because of the interleaved sampling of the input by the two sampling circuits of one ADC. Although not as bad as the $(f_S / 2 \pm f_{IN})$ spur for 8-input mode, the interleaving spur could still be the dominant factor governing the SFDR at high input frequencies.

图 21 illustrates the interleaving spur at $(f_S / 4 \pm f_{IN})$ versus the frequency of the input signal. 图 21 is taken for 8-input mode with the ADC resolution set to 10 bits. The system clock is set to 200 MSPS and the input is sampled at an effective rate of 200 MSPS. In 8-input mode, there are a total of four sampling circuits (two in each ADC) that sample the same input in sequence. The $(f_S / 4 \pm f_{IN})$ spur comes about from mismatches between these four sampling circuits.

图 22 illustrates SNR in dBFS as a function of the input amplitude, also expressed in dBFS. SNR excludes the first nine harmonics and the interleaving spurs. 图 22 is taken for the 16-input mode with the ADC resolution set to 14 bits. The system clock is set to 65 MSPS and the input is sampled at an effective rate of 65 MSPS. The points in the left extreme of the curve provide an estimate of the idle channel SNR (SNR in the absence of an input signal).

图 23 illustrates the spurious-free dynamic range (SFDR) as a function of the input amplitude. 图 23 is taken for 32-input mode with the ADC resolution set to 14 bits. In 32-input mode, there is no interleaved operation of any sort and SFDR is a true measure of ADC conversion performance. As mentioned previously, SFDR may be dominated by interleaving spurs (and significantly lower than 32-input mode) when operated in 16-input or 8-input modes. SFDR is plotted in both dBc and dBFS: the former referring the amplitude of the worst-spur to the fundamental amplitude and the latter to the full-scale voltage.

图 24 illustrates SNR as a function of the input common-mode voltage (average of INP and INM). 图 24 is taken for 16-input mode with the ADC resolution set to 14 bits. The device is meant to be operated at an input common-mode that is tightly controlled around the ideal value of 0.8 V. The driving circuit can generate its output common-mode using the 0.8-V reference voltage provided at the VCM pin.

图 25 illustrates SNR as a function of the input clock amplitude (expressed in differential V_{PP}) when driven with a differential sine-wave clock input. At small input amplitudes, the sine-wave clock has a low dV/dt slope at the zero crossings. This low slope can cause increased jitter in the clocking and can lead to a reduction in the SNR within the device. The effect is more pronounced when the input frequency is set to a higher value (as is evidenced by the difference in behavior between the 5-MHz and 50-MHz inputs). The recommended manner to drive the device is with an LVPECL clock.

图 26 illustrates SNR as a function of the duty cycle of a differential clock input. Ideally, the device is driven with a 50% clock; see the [Electrical Characteristics](#) table for the acceptable variation around 50% duty cycle.

图 27 illustrates the channel-to-channel crosstalk as a function of the analog input frequency. An analog input of a -1 -dBFS amplitude is applied on one channel and the crosstalk spur (at the input frequency) is measured on all channels. The worst of the crosstalk numbers (usually on the physically closest channel) is plotted.

图 28 illustrates the integral nonlinearity (INL) versus ADC code. The device is operated in 32-input mode at 14-bit resolution with an effective sampling rate of 32.5 MSPS. 图 28 provides an accurate INL estimate of the ADC inside the device because there is no interleaving of any kind in the 32-input mode operation.

图 29 illustrates the differential nonlinearity (DNL) versus ADC code. The device is operated in 32-input mode at 14-bit resolution with an effective sampling rate of 32.5 MSPS. The saturation of the DNL on the lower side to -1 indicates missing codes at the 14-bit level.

图 30 illustrates the power-supply rejection ratio (PSRR) as a function of the tone frequency applied on the supply. A tone is applied on the supplies and the tone at the same frequency is measured at the device output. The unit of dBc refers to the relation of the amplitude of the output tone to the amplitude of the supply tone that is set to 100 mV_{PP} for this measurement.

图 31 illustrates the power-supply modulation ratio (PSMR) as a function of the tone frequency applied on the supply. A -1 -dBFS input at 5 MHz is applied on the analog input. Simultaneously, a 100-mV_{PP} tone is applied on the supply. The tone caused by the intermodulation between the supply tone and the input tone is measured at the device output. PSMR refers to the intermodulation tone referred to in terms of dBc to the amplitude of the input tone.

图 32 illustrates the common-mode rejection ratio (CMRR) as a function of the tone frequency applied as a common-mode signal on the input pins. A 50-mV_{PP} common-mode signal is applied to INP and INM around the ideal common-mode voltage of 0.8 V. The amplitude of the tone at the same frequency is measured at the device output. CMRR refers to the amplitude of this output tone referred to in terms of dBc to the amplitude of the common-mode input tone.

图 33 illustrates the current of the AVDD_1P8 supply as a function of f_C , the conversion clock frequency. The relation of the sampling rate to the conversion clock frequency is different between the 16-, 32-, and 8- input modes and therefore the curve can be appropriately interpreted for each mode. The curve extends to a conversion clock frequency of up to 100 MSPS, which is the maximum value for the 10-bit ADC resolution. For the 12- and 14-bit ADC resolutions, sections of the same curve up to 80 MSPS and 65 MSPS (respectively) are applicable.

图 34 illustrates the current of the DVDD_1P8 supply as a function of the conversion clock frequency. All 16 LVDS buffers are on during this measurement.

图 35 illustrates the current of the DVDD_1P2 supply as a function of the conversion clock frequency.

图 36 illustrates the total power consumption as a function of the conversion clock frequency. The power per input channel can be calculated by dividing this total power by 8, 16, or 32 for the 8-, 16-, or 32-input modes.

图 37 illustrates the digital high-pass filter response for different settings of the HPF corner frequency.

图 38 illustrates the typical minimum and maximum SNR values taken across 100 devices operating in the 14-bit, 32-input mode at $f_C = 65$ MSPS (corresponding to $f_{\text{SAMP}} = 32.5$ MSPS). A trend can be observed across channels and originates from the physical placement and routing of common signals (such as reference voltage and power) to the channels. Depending on the way the channel data are combined, an averaging effect can result when the system-level SNR is computed.

图 39 illustrates a plot of the low-frequency noise from the device with and without the chopper enabled. When the chopper is enabled (using the CHOPPER_EN register control), the low-frequency noise generated inside the device is shifted to approximately $f_s / 2$. Chopper mode is useful when the signal frequency of interest is close to dc.

图 48 illustrates a contour plot of SNR as a function of both the input frequency and sampling frequency for 32-input mode operating with a 10-bit ADC resolution.

图 49 illustrates a contour plot of SNR as a function of both the input frequency and sampling frequency for 16-input mode operating with a 10-bit ADC resolution.

图 50 illustrates a contour plot of SNR as a function of both the input frequency and sampling frequency for 8-input mode operating with a 10-bit ADC resolution.

图 51 illustrates a contour plot of SNR as a function of both the input frequency and sampling frequency for 32-input mode operating with a 12-bit ADC resolution.

图 52 illustrates a contour plot of SNR as a function of both the input frequency and sampling frequency for 16-input mode operating with a 12-bit ADC resolution.

图 53 illustrates a contour plot of SNR as a function of both the input frequency and sampling frequency for 32-input mode operating with a 14-bit ADC resolution.

图 54 illustrates a contour plot of SNR as a function of both the input frequency and sampling frequency for 16-input mode operating with a 14-bit ADC resolution.

9.3 Do's and Don'ts

Driving the inputs (analog or digital) beyond the power-supply rails. For device reliability, an input must not go more than 300 mV below the ground pins or 300 mV above the supply pins. Exceeding these limits, even on a transient basis, can cause faulty or erratic operation and can impair device reliability.

Driving the device signal input with an excessively high level signal. The device offers consistent and fast overload recovery for an overload of upto 6 dBFS. For very large overload signals (> 6 dB of the linear input signal range), TI recommends back-to-back Schottky clamping diodes at the input to limit the amplitude of the input signal.

Using a clock source with excessive jitter, an excessively long input clock signal trace, or having other signals coupled to the ADC clock signal trace. These situations cause the sampling instant vary, causing an excessive output noise and a reduction in SNR performance. For a system with multiple devices, the clock tree scheme must be used to apply an ADC clock. Excessive clock delay mismatch between devices can also lead to latency mismatch and functional failure at the system level.

LVDS routing length mismatch. The routing length of all LVDS lines routing to the FPGA must be matched to avoid any timing-related issues. For systems with multiple devices, the LVDS serialized data clock (DCLKP, DCLKM) and the frame clock (FCLKP, FCLKM) of each individual device must be used to deserialize the corresponding LDVS serialized data (DOUTP, DOUTM).

Failure to provide adequate heat removal. Use the appropriate thermal parameter listed in the [Thermal Information](#) table and an ambient, board, or case temperature in order to calculate device junction temperature. A suitable heat removal technique must be used to keep the device junction temperature below the maximum limit of 105°C.

10 Power Supply Recommendations

The device requires three supplies in order to operate properly. These supplies are AVDD_1P8, DVDD_1P8, and DVDD_1P2. All supplies must be driven with low-noise sources to be able to achieve the best performance from the device. When determining the drive current needed to drive each of the supplies of the device, a margin of 50-100% over the typical current might be needed to account for the current consumption across different modes of operation.

10.1 Power Sequencing and Initialization

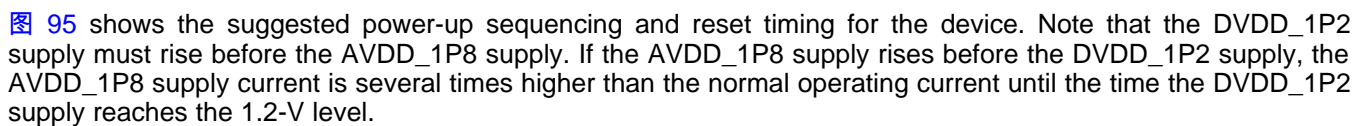
 **Figure 95** shows the suggested power-up sequencing and reset timing for the device. Note that the DVDD_1P2 supply must rise before the AVDD_1P8 supply. If the AVDD_1P8 supply rises before the DVDD_1P2 supply, the AVDD_1P8 supply current is several times higher than the normal operating current until the time the DVDD_1P2 supply reaches the 1.2-V level.

The device requires register described in [Table 43](#) to be written as part of the initialization.

表 43. Initialization Register Details

| INITIALIZATION REGISTER ADDRESS | 16-BIT DATA WORD TO BE WRITTEN |
|---------------------------------|--------------------------------|
| 0Ah | 3000h |

The initialization sequence is described below:

1. Power-up the supplies as indicated,
2. Apply a hardware reset pulse,
3. Write the initialization register listed in [Table 43](#) through the SPI interface,
4. Write other device settings through the SPI interface, and
5. After a wait time, the device is ready for high accuracy operation.

The power sequence and initialization is shown in 图 95.



图 95. Power Sequencing and Initialization

The timing parameters corresponding to 图 95 are shown in 表 44.

表 44. Timing for Power Sequencing and Initialization

| | | MIN | MAX | UNIT |
|----------------|--|----------------|------|------------|
| t ₁ | Ramp-up time of DVDD_1P2 | 10 μ | 50 m | s |
| t ₂ | Ramp up time of AVDD_1P8 and DVDD_1P8 | 10 μ | 50 m | s |
| t ₃ | Time between DVDD_1P2 and AVDD_1P8 start of ramp up | t ₁ | | |
| t ₄ | Time between supplies stabilizing and application of a hardware reset | 10 | | ms |
| t ₅ | Width of hardware reset | 100 | | ns |
| t ₆ | Time between hardware reset and SPI write for device initialization and programming of device settings | 100 | | ns |
| t ₇ | Time between programming of device settings and synchronization using TX_TRIG | 100 | | ns |
| t ₈ | Time between TX_TRIG pulse and device ready for high-accuracy operation | 10 | | ADC clocks |

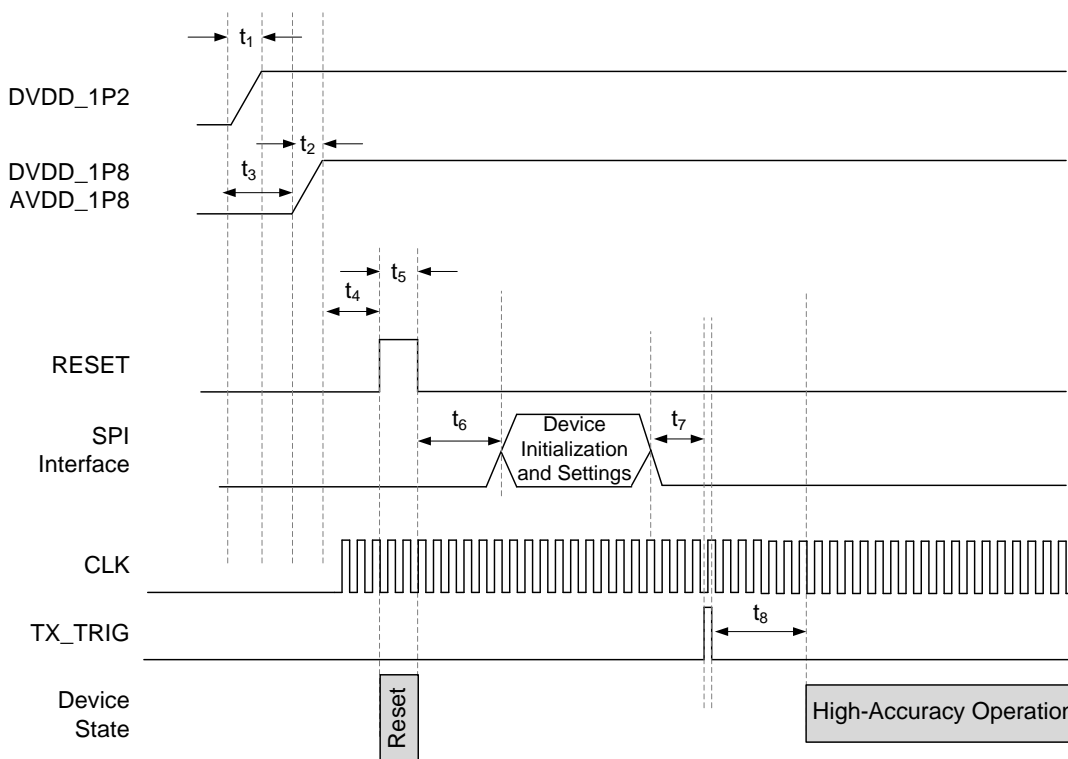
11 Layout

11.1 Power Supply, Grounding, and Bypassing

In a mixed-signal system design, the power-supply and grounding design plays a significant role. The device distinguishes between two different grounds: AVSS (analog ground) and DVSS (digital ground). In most cases, laying out the PCB to use a single ground plane is adequate. However, in high-frequency or high-performance systems, care must be taken so that this ground plane is properly partitioned between various sections within the system to minimize interactions between analog and digital circuitry. Alternatively, the digital supply set consisting of the DVDD_1P8, DVDD_1P2, and DVSS pins can be placed on separate power and ground planes. For this configuration, tie the AVSS and DVSS grounds together at the power connector in a star layout. In addition, optical or digital isolators (such as the [ISO7240](#)) can completely separate the analog portion from the digital portion. Consequently, such isolators prevent digital noise from contaminating the analog portion. [表 45](#) lists the related circuit blocks for each power supply.

表 45. Supply versus Circuit Blocks

| POWER SUPPLY | GROUND | CIRCUIT BLOCKS |
|--------------|--------|---|
| AVDD_1P8 | AVSS | ADC analog, reference voltage and current generator, band-gap circuit, and ADC clock buffer |
| DVDD_1P8 | DVSS | LVDS serializer and buffer, and PLL |
| DVDD_1P2 | DVSS | ADC digital and serial interface |

Reference all bypassing and power supplies for the device to their corresponding ground planes. Bypass all supply pins with 0.1- μ F ceramic chip capacitors (size 0603 or smaller). In order to minimize the lead and trace inductance, the capacitors must be located as close to the supply pins as possible. Where double-sided component mounting is allowed, these capacitors are best placed directly under the package. In addition, larger bipolar decoupling capacitors (2.2 μ F to 10 μ F, effective at lower frequencies) can also be used on the main supply pins. These components can be placed on the PCB in close proximity (< 0.5 inch or 12.7 mm) to the device itself.

Bypass the VCM pin with at least a 1- μ F capacitor; higher value capacitors can be used for better low-frequency noise suppression. For best results, choose low-inductance ceramic chip capacitors (size 0402, > 1 μ F) placed as close as possible to the device pin.

11.2 Layout Guidelines

High-speed, mixed-signal devices are sensitive to various types of noise coupling. One primary source of noise is the switching noise from the serializer and the output buffer and drivers. For the device, care must be taken to ensure that the interaction between the analog and digital supplies within the device is kept to a minimal amount. The extent of noise coupled and transmitted from the digital and analog sections depends on the effective inductances of each of the supply and ground connections. Smaller effective inductances of the supply and ground pins result in better noise suppression. For this reason, multiple pins are used to connect each supply and ground sets. Low inductance properties must be maintained throughout the design of the PCB layout by use of proper planes and layer thickness.

To avoid noise coupling through supply pins, TI recommends keeping sensitive input pins (such as the INM and INP pins) away from the supply planes. For example, do not route the traces or vias connected to these pins across the supply planes. That is, avoid the power planes under the INM and INP pins.

Some layout guidelines associated with the layout of the high speed interfaces are listed below:

- The length of the positive and negative traces of a differential pair must be matched to within 2 mils of each other.
- Each differential pair length must be matched within 10 mils of other differential pairs.
- When the ADC is used on the same printed circuit board (PCB) with a digital intensive component (such as an FPGA or ASIC), separate digital and analog ground planes must be used. Do not overlap these separate ground planes to minimize undesired coupling.
- Connect decoupling capacitors directly to ground and place these capacitors close to the ADC power pins and the power-supply pins to filter high-frequency current transients directly to the ground plane.
- Ground and power planes must be wide enough to keep the impedance very low. In a multilayer PCB, one layer must be dedicated to each ground and power plane.

Layout Guidelines (接下页)

- All high-speed traces must be routed straight with minimum bends. Where a bend is necessary, avoid making very sharp right-angle bends in the trace.
- In order to maintain proper LVDS timing, all LVDS traces must follow a controlled impedance design. In addition, all LVDS trace lengths must be equal and symmetrical; TI recommends keeping trace length variations less than 150 mil (0.150 inch or 3.81 mm).
- When routing CML lines, the traces must be designed for a controlled impedance of 50 Ω . The routing of different lines must be matched as much as possible to minimize the inter-lane skew. However, trace length matching is less critical for the JESD interface as compared to the LVDS interface.

Additional details on the NFBGA PCB layout techniques can be found in the Texas Instruments application report, *MicroStar BGA Packaging Reference Guide (SSYZ015)*, available from www.ti.com.

11.3 Layout Example



图 96. Example Layout

12 Register Map

12.1 ADC Registers

The register map of the device is shown in 表 46.

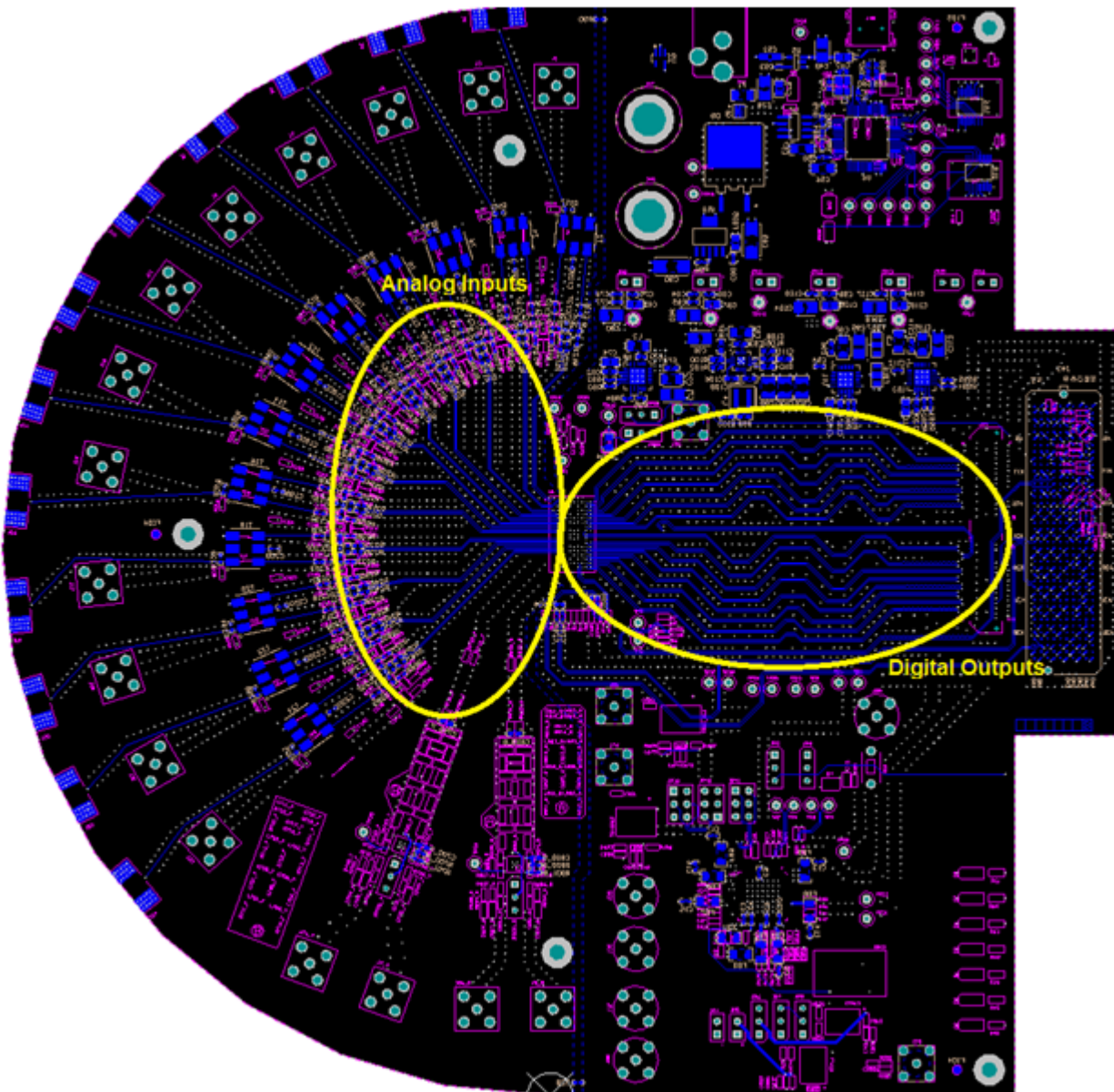
表 46. ADC Register Map

| REGISTER ADDRESS (Hex) | REGISTER DATA ⁽¹⁾ | | | | | | | | | | | | | | | | |
|---------------------------|-----------------------------------|--------------------------|-----------------------------|--------------------------------|--------------|-------------------------------------|--------------|---------------|--------------|------------------|-------------------------------------|--------------------|-------------------|--------------|--------------|-------------------|------------|
| | 15 | 14 | 13 | 12 | 11 | 10 | 9 | 8 | 7 | 6 | 5 | 4 | 3 | 2 | 1 | 0 | |
| 0 | 0 | 0 | 0 | 0 | 0 | 0 | 0 | 0 | 0 | 0 | 0 | 0 | 0 | 0 | REG_READ_EN | RESET | |
| 1 | 0 | LVDS_RATE_2X | 0 | 0 | 0 | 0 | 0 | 0 | SEL_CH[2] | EN_JESD | DIS_LVDS | SEL_CH[1] | 0 | SEL_CH[0] | 0 | GLOBAL_PDN | |
| 2 | PAT_MODES_FCLK | | | LOW_LATENCY_EN | AVG_EN | SEL_PRBS_PAT_FCLK | PAT_MODES | | | SEL_PRBS_PAT_GBL | OFFSET_CORR_DELAY_FROM_TX_TRIG[5:0] | | | | | | |
| 3 | SER_DATA_RATE | | | DIG_GAIN_EN | 0 | OFFSET_CORR_DELAY_FROM_TX_TRIG[7:6] | | DIG_OFFSET_EN | 0 | 0 | JESD_WR_SEL | 0 | 0 | 0 | 0 | 0 | |
| 4 | OFFSET_REMOVAL_SELF | OFFSET_REMOVAL_START_SEL | OFFSET_REMOVAL_START_MANUAL | AUTO_OFFSET_REMOVAL_ACC_CYCLES | | | | PAT_SEL_IND | PRBS_SYNC | PRBS_MODE | PRBS_EN | MSB_FIRST | 0 | 0 | ADC_RES | | |
| 5 | CUSTOM_PATTERN | | | | | | | | | | | | | | | | |
| 7 | AUTO_OFFSET_REMOVAL_VAL_RD_CH_SEL | | | | | 0 | 0 | 0 | 0 | 0 | 0 | 0 | 0 | 0 | 0 | 0 | CHOPPER_EN |
| 8 | 0 | 0 | AUTO_OFFSET_REMOVAL_VAL_RD | | | | | | | | | | | | | | |
| A | 0 | 0 | INIT2 | INIT1 | 0 | 0 | 0 | 0 | 0 | 0 | 0 | 0 | 0 | 0 | 0 | 0 | |
| B | 0 | 0 | 0 | 0 | EN_DITHER | 0 | 0 | 0 | 0 | 0 | 0 | 0 | 0 | 0 | 0 | 0 | |
| D | GAIN_ADC1o | | | | | 0 | OFFSET_ADC1o | | | | | | | | | | |
| E | GAIN_ADC1e | | | | | 0 | OFFSET_ADC1e | | | | | | | | | | |
| F | GAIN_ADC2o | | | | | 0 | OFFSET_ADC2o | | | | | | | | | | |
| 10 | GAIN_ADC2e | | | | | 0 | OFFSET_ADC2e | | | | | | | | | | |
| 11 | GAIN_ADC3o | | | | | 0 | OFFSET_ADC3o | | | | | | | | | | |
| 12 | GAIN_ADC3e | | | | | 0 | OFFSET_ADC3e | | | | | | | | | | |
| 13 | GAIN_ADC4o | | | | | 0 | OFFSET_ADC4o | | | | | | | | | | |
| 14 | GAIN_ADC4e | | | | | 0 | OFFSET_ADC4e | | | | | | | | | | |
| 15 | PAT_PRBS_LVDS1 | PAT_PRBS_LVDS2 | PAT_PRBS_LVDS3 | PAT_PRBS_LVDS4 | PAT_LVDS1 | | | | PAT_LVDS2 | | | HPF_ROUND_EN_CH1-8 | HPF_CORNER_ADC1-4 | | | DIG_HPF_EN_ADC1-4 | |
| 17 | 0 | 0 | 0 | 0 | IN_16CH_ADC1 | IN_16CH_ADC2 | IN_16CH_ADC3 | IN_16CH_ADC4 | PAT_LVDS3 | | | PAT_LVDS4 | | | 0 | 0 | |
| 18 | PDN_DIG_ADC4 | PDN_DIG_ADC3 | PDN_DIG_ADC2 | PDN_DIG_ADC1 | PDN_LVDS4 | PDN_LVDS3 | PDN_LVDS2 | PDN_LVDS1 | PDN_ANA_ADC4 | PDN_ANA_ADC3 | PDN_ANA_ADC2 | PDN_ANA_ADC1 | INVERT_LVDS4 | INVERT_LVDS3 | INVERT_LVDS2 | INVERT_LVDS1 | |

(1) Default value of all registers is 0.

ADC Registers (接下页)
表 46. ADC Register Map (接下页)

| REGISTER ADDRESS (Hex) | REGISTER DATA ⁽¹⁾ | | | | | | | | | | | | | | | |
|---------------------------|------------------------------|-----------------|-----------------|-----------------|--------------|---------------|---------------|---------------|---------------|---------------|---------------------|--------------------|---------------|---------------|---------------|-----------------------|
| | 15 | 14 | 13 | 12 | 11 | 10 | 9 | 8 | 7 | 6 | 5 | 4 | 3 | 2 | 1 | 0 |
| 19 | GAIN_ADC5o | | | | | 0 | OFFSET_ADC5o | | | | | | | | | |
| 1A | GAIN_ADC5e | | | | | 0 | OFFSET_ADC5e | | | | | | | | | |
| 1B | GAIN_ADC6o | | | | | 0 | OFFSET_ADC6o | | | | | | | | | |
| 1C | GAIN_ADC6e | | | | | 0 | OFFSET_ADC6e | | | | | | | | | |
| 1D | GAIN_ADC7o | | | | | 0 | OFFSET_ADC7o | | | | | | | | | |
| 1E | GAIN_ADC7e | | | | | 0 | OFFSET_ADC7e | | | | | | | | | |
| 1F | GAIN_ADC8o | | | | | 0 | OFFSET_ADC8o | | | | | | | | | |
| 20 | GAIN_ADC8e | | | | | 0 | OFFSET_ADC8e | | | | | | | | | |
| 21 | PAT_PRBS_LVDS5 | PAT_PRBS_LVDS6 | PAT_PRBS_LVDS7 | PAT_PRBS_LVDS8 | PAT_LVDS5 | | | PAT_LVDS6 | | | 0 | HPF_CORNER_ADC5-8 | | | | DIG_HPFCORNER_ADC5-8 |
| 23 | 0 | 0 | 0 | 0 | IN_16CH_ADC5 | IN_16CH_ADC6 | IN_16CH_ADC7 | IN_16CH_ADC8 | PAT_LVDS7 | | | PAT_LVDS8 | | | 0 | 0 |
| 24 | PDN_DIG_ADC8 | PDN_DIG_ADC7 | PDN_DIG_ADC6 | PDN_DIG_ADC5 | PDN_LVDS8 | PDN_LVDS7 | PDN_LVDS6 | PDN_LVDS5 | PDN_ANA_ADC8 | PDN_ANA_ADC7 | PDN_ANA_ADC6 | PDN_ANA_ADC5 | INVERT_LVDS8 | INVERT_LVDS7 | INVERT_LVDS6 | INVERT_LVDS5 |
| 25 | GAIN_ADC9o | | | | | 0 | OFFSET_ADC9o | | | | | | | | | |
| 26 | GAIN_ADC9e | | | | | 0 | OFFSET_ADC9e | | | | | | | | | |
| 27 | GAIN_ADC10o | | | | | 0 | OFFSET_ADC10o | | | | | | | | | |
| 28 | GAIN_ADC10e | | | | | 0 | OFFSET_ADC10e | | | | | | | | | |
| 29 | GAIN_ADC11o | | | | | 0 | OFFSET_ADC11o | | | | | | | | | |
| 2A | GAIN_ADC11e | | | | | 0 | OFFSET_ADC11e | | | | | | | | | |
| 2B | GAIN_ADC12o | | | | | 0 | OFFSET_ADC12o | | | | | | | | | |
| 2C | GAIN_ADC12e | | | | | 0 | OFFSET_ADC12e | | | | | | | | | |
| 2D | PAT_PRBS_LVDS9 | PAT_PRBS_LVDS10 | PAT_PRBS_LVDS11 | PAT_PRBS_LVDS12 | PAT_LVDS9 | | | PAT_LVDS10 | | | HPF_ROUND_EN_CH9-16 | HPF_CORNER_ADC9-12 | | | | DIG_HPFCORNER_ADC9-12 |
| 2F | 0 | 0 | 0 | 0 | IN_16CH_ADC9 | IN_16CH_ADC10 | IN_16CH_ADC11 | IN_16CH_ADC12 | PAT_LVDS11 | | | PAT_LVDS12 | | | 0 | 0 |
| 30 | PDN_DIG_ADC12 | PDN_DIG_ADC11 | PDN_DIG_ADC10 | PDN_DIG_ADC9 | PDN_LVDS12 | PDN_LVDS11 | PDN_LVDS10 | PDN_LVDS9 | PDN_ANA_ADC12 | PDN_ANA_ADC11 | PDN_ANA_ADC10 | PDN_ANA_ADC9 | INVERT_LVDS12 | INVERT_LVDS11 | INVERT_LVDS10 | INVERT_LVDS9 |

ADC Registers (接下页)
表 46. ADC Register Map (接下页)

| REGISTER ADDRESS (Hex) | REGISTER DATA ⁽¹⁾ | | | | | | | | | | | | | | | | |
|---------------------------|------------------------------|-----------------|-----------------|-----------------|---------------|---------------|---------------|---------------|---------------|---------------|---------------|----------------------|---------------|---------------------|---------------|---------------|---------------------|
| | 15 | 14 | 13 | 12 | 11 | 10 | 9 | 8 | 7 | 6 | 5 | 4 | 3 | 2 | 1 | 0 | |
| 31 | GAIN_ADC13o | | | | | 0 | OFFSET_ADC13o | | | | | | | | | | |
| 32 | GAIN_ADC13e | | | | | 0 | OFFSET_ADC13e | | | | | | | | | | |
| 33 | GAIN_ADC14o | | | | | 0 | OFFSET_ADC14o | | | | | | | | | | |
| 34 | GAIN_ADC14e | | | | | 0 | OFFSET_ADC14e | | | | | | | | | | |
| 35 | GAIN_ADC15o | | | | | 0 | OFFSET_ADC15o | | | | | | | | | | |
| 36 | GAIN_ADC15e | | | | | 0 | OFFSET_ADC15e | | | | | | | | | | |
| 37 | GAIN_ADC16o | | | | | 0 | OFFSET_ADC16o | | | | | | | | | | |
| 38 | GAIN_ADC16e | | | | | 0 | OFFSET_ADC16e | | | | | | | | | | |
| 39 | PAT_PRBS_LVDS13 | PAT_PRBS_LVDS14 | PAT_PRBS_LVDS15 | PAT_PRBS_LVDS16 | PAT_LVDS13 | | | | PAT_LVDS14 | | | | 0 | HPF_CORNER_ADC13-16 | | | DIG_HP_FEN_ADC13-16 |
| 3B | 0 | 0 | 0 | 0 | IN_16CH_ADC13 | IN_16CH_ADC14 | IN_16CH_ADC15 | IN_16CH_ADC16 | PAT_LVDS15 | | | | PAT_LVDS16 | | | 0 | 0 |
| 3C | PDN_DIG_ADC16 | PDN_DIG_ADC15 | PDN_DIG_ADC14 | PDN_DIG_ADC13 | PDN_LVDS16 | PDN_LVDS15 | PDN_LVDS14 | PDN_LVDS13 | PDN_ANA_ADC16 | PDN_ANA_ADC15 | PDN_ANA_ADC14 | PDN_ANA_ADC13 | INVERT_LVDS16 | INVERT_LVDS15 | INVERT_LVDS14 | INVERT_LVDS13 | |
| 43 | 0 | 0 | 0 | 0 | 0 | 0 | 0 | 0 | 0 | 0 | 0 | LVDS_DCLK_DELAY_PROG | | | | | |

12.1.1 Description of Registers

12.1.1.1 Register 0h (address = 0h)

图 97. Register 0h

| | | | | | | | |
|------|------|------|------|------|------|-------------|-------|
| 15 | 14 | 13 | 12 | 11 | 10 | 9 | 8 |
| 0 | 0 | 0 | 0 | 0 | 0 | 0 | 0 |
| W-0h | W-0h | W-0h | W-0h | W-0h | W-0h | W-0h | W-0h |
| 7 | 6 | 5 | 4 | 3 | 2 | 1 | 0 |
| 0 | 0 | 0 | 0 | 0 | 0 | REG_READ_EN | RESET |
| W-0h | W-0h | W-0h | W-0h | W-0h | W-0h | W-0h | W-0h |

LEGEND: R/W = Read/Write; W = Write only; -n = value after reset

表 47. Register 0h Field Descriptions

| Bit | Field | Type | Reset | Description |
|------|-------------|------|-------|--|
| 15-2 | 0 | W | 0h | Must write 0 |
| 1 | REG_READ_EN | W | 0h | Register readout enabled. 0 = Disabled 1 = Enabled; see the Serial Peripheral Interface (SPI) Operation section for further details. |
| 0 | RESET | W | 0h | 0 = Disabled 1 = Enabled (this setting returns the device to a reset state; this bit is self-clearing bit) |

12.1.1.2 Register 1h (address = 1h)

图 98. Register 1h

| | | | | | | | |
|-----------|--------------|----------|-----------|--------|-----------|--------|------------|
| 15 | 14 | 13 | 12 | 11 | 10 | 9 | 8 |
| 0 | LVDS_RATE_2X | 0 | 0 | 0 | 0 | 0 | 0 |
| R/W-0h | R/W-0h | R/W-0h | R/W-0h | R/W-0h | R/W-0h | R/W-0h | R/W-0h |
| 7 | 6 | 5 | 4 | 3 | 2 | 1 | 0 |
| SEL_CH[2] | EN_JESD | DIS_LVDS | SEL_CH[1] | 0 | SEL_CH[0] | 0 | GLOBAL_PDN |
| R/W-0h | R/W-0h | R/W-0h | R/W-0h | R/W-0h | R/W-0h | R/W-0h | R/W-0h |

LEGEND: R/W = Read/Write; -n = value after reset

表 48. Register 1h Field Descriptions

| Bit | Field | Type | Reset | Description |
|------|--------------|------|-------|--|
| 15 | 0 | R/W | 0h | Must write 0 |
| 14 | LVDS_RATE_2X | R/W | 0h | 0 = 1X rate; normal operation (default) 1 = 2X rate. This setting combines the data of two LVDS pairs into a single LVDS pair. This feature can be used when the ADC clock rate is low. |
| 13-8 | 0 | R/W | 0h | Must write 0 |
| 7 | SEL_CH[2] | R/W | 0h | Input mode selection bit 3. 表 49 lists bit settings for the three input modes. |
| 6 | EN_JESD | R/W | 0h | 0 = JESD interface disabled 1 = JESD interface enabled; see 表 49 |
| 5 | DIS_LVDS | R/W | 0h | 0 = LVDS interface is enabled (default) 1 = LVDS interface is disabled |
| 4 | SEL_CH[1] | R/W | 0h | Input mode selection bit 2. 表 49 lists bit settings for the three input modes. |
| 3 | 0 | R/W | 0h | Must write 0 |
| 2 | SEL_CH[0] | R/W | 0h | Input mode selection bit 1. 表 49 lists bit settings for the three input modes. |
| 1 | 0 | R/W | 0h | Must write 0 |
| 0 | GLOBAL_PDN | R/W | 0h | 0 = The device operates in normal mode (default) 1 = ADC enters complete power-down mode |

表 49. 8-, 16-, and 32-Input Mode Selection

| INPUT MODE | SEL_CH[2] | SEL_CH[1] | SEL_CH[0] |
|------------------|-----------|-----------|-----------|
| 8-channel input | 1 | 1 | 1 |
| 16-channel input | 0 | 1 | 1 |
| 32-channel input | 0 | 0 | 0 |

表 50. Output Interface Supported in 8-, 16-, and 32-Input Mode

| INPUT MODE | OUTPUT INTERFACE SUPPORTED? | |
|------------------|-----------------------------|----------|
| | LVDS | JESD204B |
| 8-channel input | Yes | No |
| 16-channel input | Yes | Yes |
| 32-channel input | Yes | Yes |

12.1.1.3 Register 2h (address = 2h)

图 99. Register 2h

| | | | | | | | | | | | | | | | |
|---------------------|--|------------------|--|-------------------------------------|--|--------|--|-------------------|--|----------------|--|---|--|---|--|
| 15 | | 14 | | 13 | | 12 | | 11 | | 10 | | 9 | | 8 | |
| PAT_MODES_FCLK[2:0] | | | | LOW_LATENCY_EN | | AVG_EN | | SEL_PRBS_PAT_FCLK | | PAT_MODES[2:0] | | | | | |
| R/W-0h | | | | R/W-0h | | R/W-0h | | R/W-0h | | R/W-0h | | | | | |
| 7 | | 6 | | 5 | | 4 | | 3 | | 2 | | 1 | | 0 | |
| PAT_MODES[2:0] | | SEL_PRBS_PAT_GBL | | OFFSET_CORR_DELAY_FROM_TX_TRIG[5:0] | | | | | | | | | | | |
| R/W-0h | | R/W-0h | | R/W-0h | | | | | | | | | | | |

LEGEND: R/W = Read/Write; -n = value after reset

表 51. Register 2h Field Descriptions

| Bit | Field | Type | Reset | Description |
|-------|-------------------------------------|------|-------|---|
| 15-13 | PAT_MODES_FCLK[2:0] | R/W | 0h | These bits enable different test patterns on the frame clock line; see 表 52 for bit descriptions and the <i>LVDS Test Pattern Mode</i> section for further details. |
| 12 | LOW_LATENCY_EN | R/W | 0h | 0 = Default latency with digital features supported 1 = Low-latency with digital features bypassed |
| 11 | AVG_EN | R/W | 0h | 0 = No digital averaging 1 = Enables digital averaging of two channels to improve signal-to-noise ratio (SNR) |
| 10 | SEL_PRBS_PAT_FCLK | R/W | 0h | 0 = Normal operation 1 = Enables the PRBS pattern to be generated on FCLK; see the <i>LVDS Test Pattern Mode</i> section for further details. |
| 9-7 | PAT_MODES[2:0] | R/W | 0h | These bits enable different test patterns on the LVDS data lines; see 表 52 for bit descriptions and the <i>LVDS Test Pattern Mode</i> section for further details. |
| 6 | SEL_PRBS_PAT_GBL | R/W | 0h | 0 = Normal operation 1 = Enables the PRBS pattern to be generated on all the LVDS data lines; see the <i>LVDS Test Pattern Mode</i> section for further details. |
| 5-0 | OFFSET_CORR_DELAY_FROM_TX_TRIG[5:0] | R/W | 0h | This is a part of an 8-bit control that initiates offset correction after the TX_TRIG input pulse (each step is equivalent to one sample delay); the remaining two MSB bits are the OFFSET_CORR_DELAY_FROM_TX_TRIG[7:6] bits (bits 10-9) in register 3. |

表 52. Pattern Mode Bit Description⁽¹⁾

| PAT_MODES[2:0] or PAT_MODES_FCLK[2:0] or PAT_LVDSx[2:0] | DESCRIPTION |
|---|-----------------------------------|
| 000 | Normal operation |
| 001 | Sync (half frame 1, half frame 0) |
| 010 | Deskew |
| 011 | Custom ⁽²⁾ |
| 100 | All 1s |
| 101 | Toggle mode |
| 110 | All 0s |
| 111 | Ramp ⁽²⁾ |

(1) For detailed description, see 表 33.

(2) Either the custom or ramp pattern setting is required for PRBS pattern selection.

12.1.1.4 Register 3h (address = 3h)
图 100. Register 3h

| | | | | | | | | | | | | | | | |
|---------------|--|--------|--|-------------|--|--------|--|-------------------------------------|--|--------|--|---------------|--|--------|--|
| 15 | | 14 | | 13 | | 12 | | 11 | | 10 | | 9 | | 8 | |
| SER_DATA_RATE | | | | DIG_GAIN_EN | | 0 | | OFFSET_CORR_DELAY_FROM_TX_TRIG[7:6] | | | | DIG_OFFSET_EN | | | |
| R/W-0h | | | | R/W-0h | | R/W-0h | | R/W-0h | | | | R/W-0h | | | |
| 7 | | 6 | | 5 | | 4 | | 3 | | 2 | | 1 | | 0 | |
| 0 | | 0 | | JESD_WR_SEL | | 0 | | 0 | | 0 | | 0 | | 0 | |
| R/W-0h | | R/W-0h | | R/W-0h | | R/W-0h | | R/W-0h | | R/W-0h | | R/W-0h | | R/W-0h | |

LEGEND: R/W = Read/Write; -n = value after reset

表 53. Register 3h Field Descriptions

| Bit | Field | Type | Reset | Description |
|-------|-------------------------------------|------|-------|--|
| 15-13 | SER_DATA_RATE | R/W | 0h | These bits control the LVDS serialization rate. 000 = 12X 001 = 14X 100 = 16X 011 = 10X 101, 110, 111, 010 = Unused |
| 12 | DIG_GAIN_EN | R/W | 0h | 0 = Digital gain disabled 1 = Digital gain enabled |
| 11 | 0 | R/W | 0h | Must write 0 |
| 10-9 | OFFSET_CORR_DELAY_FROM_TX_TRIG[7:6] | R/W | 0h | This is a part of an 8-bit control that initiates offset correction after the TX_TRIG input pulse (each step is equivalent to one sample delay); the remaining six LSB bits are the OFFSET_CORR_DELAY_FROM_TX_TRIG[5:0] bits (bits 5-0) in register 2. |
| 8 | DIG_OFFSET_EN | R/W | 0h | 0 = Digital offset subtraction disabled 1 = Digital offset subtraction enabled |
| 7-6 | 0 | R/W | 0h | Must write 0 |
| 5 | JESD_WR_SEL | R/W | 0h | 0 = Setting when writing to all registers except for registers with addresses in the decimal range of 115-119 and 134-138 1 = Setting when writing to registers with addresses in the decimal range of 115-119 and 134-138 |
| 4-0 | 0 | R/W | 0h | Must write 0 |

12.1.1.5 Register 4h (address = 4h)
图 101. Register 4h

| 15 | 14 | 13 | 12 | 11 | 10 | 9 | 8 |
|---------------------|--------------------------|-----------------------------|-------------------------------------|--------|--------|----------------|---|
| OFFSET_REMOVAL_SELF | OFFSET_REMOVAL_START_SEL | OFFEST_REMOVAL_START_MANUAL | AUTO_OFFSET_REMOVAL_ACC_CYCLES[3:0] | | | PAT_SELECT_IND | |
| R/W-0h | R/W-0h | R/W-0h | R/W-0h | | | R/W-0h | |
| 7 | 6 | 5 | 4 | 3 | 2 | 1 | 0 |
| PRBS_SYNC | PRBS_MODE | PRBS_EN | MSB_FIRST | 0 | 0 | ADC_RES | |
| R/W-0h | R/W-0h | R/W-0h | R/W-0h | R/W-0h | R/W-0h | R/W-0h | |

LEGEND: R/W = Read/Write; -n = value after reset

表 54. Register 4h Field Descriptions

| Bit | Field | Type | Reset | Description |
|------|--------------------------------|------|-------|--|
| 15 | OFFSET_REMOVAL_SELF | R/W | 0h | Auto offset removal mode is enabled when this bit is set to 1 |
| 14 | OFFSET_REMOVAL_START_SEL | R/W | 0h | 0 = Auto offset correction initiated when the OFFSET_REMOVAL_START_MANUAL bit is set to 1. 1 = Auto offset correction initiated with a pulse on TX_TRIG pin. |
| 13 | OFFSET_REMOVAL_START_MANUAL | R/W | 0h | This bit initiates offset correction when OFFSET_REMOVAL_START_SEL is set to 0. |
| 12-9 | AUTO_OFFSET_REMOVAL_ACC_CYCLES | R/W | 0h | These bits define the number of samples required to generate an offset in auto offset correction mode |
| 8 | PAT_SELECT_IND | R/W | 0h | 0 = All LVDS output data lines have the same pattern, as determined by the PAT_MODES[2:0] bits 1 = Different test patterns can be sent on different LVDS data lines; see the LVDS Test Pattern Mode section for further details |
| 7 | PRBS_SYNC | R/W | 0h | 0 = Normal operation 1 = PRBS generator is in a reset state |
| 6 | PRBS_MODE | R/W | 0h | 0 = 23-bit PRBS generator 1 = 9-bit PRBS generator |
| 5 | PRBS_EN | R/W | 0h | 0 = PRBS sequence generation block disabled 1 = PRBS sequence generation block enabled; see the LVDS Test Pattern Mode section for further details |
| 4 | MSB_FIRST | R/W | 0h | 0 = The LSB is transmitted first on serialized output data 1 = The MSB is transmitted first on serialized output data |
| 3-2 | 0 | R/W | 0h | Must write 0 |
| 1-0 | ADC_RES | R/W | 0h | These bits control the ADC resolution. 00 = 12-bit resolution 01 = 14-bit resolution 11 = 10-bit resolution 10 = Unused |

12.1.1.6 Register 5h (address = 5h)

图 102. Register 5h

| | | | | | | | |
|----------------|----|----|----|----|----|---|---|
| 15 | 14 | 13 | 12 | 11 | 10 | 9 | 8 |
| CUSTOM_PATTERN | | | | | | | |
| R/W-0h | | | | | | | |
| 7 | 6 | 5 | 4 | 3 | 2 | 1 | 0 |
| CUSTOM_PATTERN | | | | | | | |
| R/W-0h | | | | | | | |

LEGEND: R/W = Read/Write; -n = value after reset

表 55. Register 5h Field Descriptions

| Bit | Field | Type | Reset | Description |
|------|----------------|------|-------|---|
| 15-0 | CUSTOM_PATTERN | R/W | 0h | If the pattern mode is programmed to a custom pattern mode, then the custom pattern value can be provided by programming these bits; see the <i>LVDS Test Pattern Mode</i> section for further details. |

12.1.1.7 Register 7h (address = 7h)

图 103. Register 7h

| | | | | | | | | |
|-----------------------------------|--------|--------|--------|--------|--------|--------|------------|--------|
| 15 | 14 | 13 | 12 | 11 | 10 | 9 | 8 | |
| AUTO_OFFSET_REMOVAL_VAL_RD_CH_SEL | | | | | | 0 | 0 | 0 |
| R/W-0h | | | | | | R/W-0h | R/W-0h | R/W-0h |
| 7 | 6 | 5 | 4 | 3 | 2 | 1 | 0 | |
| 0 | 0 | 0 | 0 | 0 | 0 | 0 | CHOPPER_EN | |
| R/W-0h | R/W-0h | R/W-0h | R/W-0h | R/W-0h | R/W-0h | R/W-0h | R/W-0h | |

LEGEND: R/W = Read/Write; -n = value after reset

表 56. Register 7h Field Descriptions

| Bit | Field | Type | Reset | Description |
|-------|-----------------------------------|------|-------|--|
| 15-11 | AUTO_OFFSET_REMOVAL_VAL_RD_CH_SEL | R/W | 0h | Write the channel number to read the offset value in auto offset correction mode for a corresponding channel number (read the offset value in AUTO_OFFSET_REMOVAL_VAL_RD. ⁽¹⁾) |
| 10-1 | 0 | R/W | 0h | Must write 0 |
| 0 | CHOPPER_EN | R/W | 0h | The chopper can be used to move low-frequency, $1 / f$ noise to $f_S / 2$ frequency. 0 = Chopper disabled 1 = Chopper enabled |

(1) In 32-channel input mode, the value written in this register corresponds to the channel number (minus 1). When operating in 8- and 16-input modes, the value can be mapped to the odd or even data streams of the 16 ADCs. For example, a value of 0 corresponds to the odd data stream of ADC1. Likewise, a value of 1 corresponds to the even data stream of ADC1, and so on respectively.

12.1.1.8 Register 8h (address = 8h)

图 104. Register 8h

| | | | | | | | |
|----------------------------------|--------|----------------------------------|----|----|----|---|---|
| 15 | 14 | 13 | 12 | 11 | 10 | 9 | 8 |
| 0 | 0 | AUTO_OFFSET_REMOVAL_VAL_RD[13:0] | | | | | |
| R/W-0h | R/W-0h | R/W-0h | | | | | |
| 7 | 6 | 5 | 4 | 3 | 2 | 1 | 0 |
| AUTO_OFFSET_REMOVAL_VAL_RD[13:0] | | | | | | | |
| R/W-0h | | | | | | | |

LEGEND: R/W = Read/Write; -n = value after reset

表 57. Register 8h Field Descriptions

| Bit | Field | Type | Reset | Description |
|-------|----------------------------|------|-------|--|
| 15-14 | 0 | R/W | 0h | Must write 0 |
| 13-0 | AUTO_OFFSET_REMOVAL_VAL_RD | R/W | 0h | Read the offset value applied in auto offset correction mode for a specific channel number as defined in AUTO_OFFSET_REMOVAL_VAL_RD_CH_SEL |

12.1.1.9 Register Ah (address = Ah)

图 105. Register Ah

| | | | | | | | |
|--------|--------|--------|--------|--------|--------|--------|--------|
| 15 | 14 | 13 | 12 | 11 | 10 | 9 | 8 |
| 0 | 0 | INIT2 | INIT1 | 0 | 0 | 0 | 0 |
| R/W-0h | R/W-0h | R/W-0h | R/W-0h | R/W-0h | R/W-0h | R/W-0h | R/W-0h |
| 7 | 6 | 5 | 4 | 3 | 2 | 1 | 0 |
| 0 | 0 | 0 | 0 | 0 | 0 | 0 | 0 |
| R/W-0h | R/W-0h | R/W-0h | R/W-0h | R/W-0h | R/W-0h | R/W-0h | R/W-0h |

LEGEND: R/W = Read/Write; -n = value after reset

表 58. Register Ah Field Descriptions

| Bit | Field | Type | Reset | Description |
|-------|-------|------|-------|---|
| 15-14 | 0 | R/W | 0h | Must write 0 |
| 13 | INIT2 | R/W | 0h | Write 1 as part of the initialization after power-up ⁽¹⁾ |
| 12 | INIT1 | R/W | 0h | Write 1 as part of the initialization after power-up ⁽¹⁾ |
| 11-0 | 0 | R/W | 0h | Must write 0 |

(1) See 表 43.

12.1.1.10 Register Bh (address = Bh)
图 106. Register Bh

| | | | | | | | | | | | | | | | |
|--------|--|--------|--|--------|--|--------|--|-----------|--|--------|--|--------|--|--------|--|
| 15 | | 14 | | 13 | | 12 | | 11 | | 10 | | 9 | | 8 | |
| 0 | | 0 | | 0 | | 0 | | EN_DITHER | | 0 | | 0 | | 0 | |
| R/W-0h | | R/W-0h | | R/W-0h | | R/W-0h | | R/W-0h | | R/W-0h | | R/W-0h | | R/W-0h | |
| 7 | | 6 | | 5 | | 4 | | 3 | | 2 | | 1 | | 0 | |
| 0 | | 0 | | 0 | | 0 | | 0 | | 0 | | 0 | | 0 | |
| R/W-0h | | R/W-0h | | R/W-0h | | R/W-0h | | R/W-0h | | R/W-0h | | R/W-0h | | R/W-0h | |

LEGEND: R/W = Read/Write; -n = value after reset

表 59. Register Bh Field Descriptions

| Bit | Field | Type | Reset | Description |
|-------|-----------|------|-------|---|
| 15-12 | 0 | R/W | 0h | Must write 0 |
| 11 | EN_DITHER | R/W | 0h | Dither can be used to reduce the power in higher-order harmonics. 0 = Dither disabled 1 = Dither enabled Note: Enabling the dither converts higher-order harmonics power into noise. Thus, enabling this mode reduce the power in higher-order harmonics but degrades SNR. |
| 10-0 | 0 | R/W | 0h | Must write 0 |

12.1.1.11 Register Dh (address = Dh)

图 107. Register Dh

| | | | | | | | |
|--------------|----|----|----|----|--------|--------------|---|
| 15 | 14 | 13 | 12 | 11 | 10 | 9 | 8 |
| GAIN_ADC1o | | | | | 0 | OFFSET_ADC1o | |
| R/W-0h | | | | | R/W-0h | R/W-0h | |
| 7 | 6 | 5 | 4 | 3 | 2 | 1 | 0 |
| OFFSET_ADC1o | | | | | | | |
| R/W-0h | | | | | | | |

LEGEND: R/W = Read/Write; -n = value after reset

表 60. Register Dh Field Descriptions

| Bit | Field | Type | Reset | Description |
|-------|--------------|------|-------|--|
| 15-11 | GAIN_ADC1o | R/W | 0h | When the DIG_GAIN_EN bit (register 3, bit 12) is set to 1, the digital gain value for the odd sample of ADC1 can be obtained with this register. For a value of N (decimal equivalent of binary) written to these bits, the digital gain gets set to N × 0.2 dB. |
| 10 | 0 | R/W | 0h | Must write 0 |
| 9-0 | OFFSET_ADC1o | R/W | 0h | When the DIG_OFFSET_EN bit (register 3, bit 8) is set to 1, the offset value to be subtracted from the odd sample of ADC1 can be obtained with this 10-bit register. The offset value is in twos complement format and its LSB corresponds to a 14-bit LSB. |

12.1.1.12 Register Eh (address = Eh)

图 108. Register Eh

| | | | | | | | |
|--------------|----|----|----|----|--------|--------------|---|
| 15 | 14 | 13 | 12 | 11 | 10 | 9 | 8 |
| GAIN_ADC1e | | | | | 0 | OFFSET_ADC1e | |
| R/W-0h | | | | | R/W-0h | R/W-0h | |
| 7 | 6 | 5 | 4 | 3 | 2 | 1 | 0 |
| OFFSET_ADC1e | | | | | | | |
| R/W-0h | | | | | | | |

LEGEND: R/W = Read/Write; -n = value after reset

表 61. Register Eh Field Descriptions

| Bit | Field | Type | Reset | Description |
|-------|--------------|------|-------|---|
| 15-11 | GAIN_ADC1e | R/W | 0h | When the DIG_GAIN_EN bit (register 3, bit 12) is set to 1, the digital gain value for the even sample of ADC1 can be obtained with this register. For a value of N (decimal equivalent of binary) written to these bits, the digital gain gets set to N × 0.2 dB. |
| 10 | 0 | R/W | 0h | Must write 0 |
| 9-0 | OFFSET_ADC1e | R/W | 0h | When the DIG_OFFSET_EN bit (register 3, bit 8) is set to 1, the offset value to be subtracted from the even sample of ADC1 can be obtained with this 10-bit register. The offset value is in twos complement format and its LSB corresponds to a 14-bit LSB. |

12.1.1.13 Register Fh (address = Fh)

图 109. Register Fh

| | | | | | | | |
|--------------|----|----|----|----|--------|--------------|---|
| 15 | 14 | 13 | 12 | 11 | 10 | 9 | 8 |
| GAIN_ADC2o | | | | | 0 | OFFSET_ADC2o | |
| R/W-0h | | | | | R/W-0h | R/W-0h | |
| 7 | 6 | 5 | 4 | 3 | 2 | 1 | 0 |
| OFFSET_ADC2o | | | | | | | |
| R/W-0h | | | | | | | |

LEGEND: R/W = Read/Write; -n = value after reset

表 62. Register Fh Field Descriptions

| Bit | Field | Type | Reset | Description |
|-------|--------------|------|-------|---|
| 15-11 | GAIN_ADC2o | R/W | 0h | When the DIG_GAIN_EN bit (register 3, bit 12) is set to 1, the digital gain value for the odd sample of ADC2 can be obtained with this register. For a value of N (decimal equivalent of binary) written to these bits, the digital gain gets set to $N \times 0.2$ dB. |
| 10 | 0 | R/W | 0h | Must write 0 |
| 9-0 | OFFSET_ADC2o | R/W | 0h | When the DIG_OFFSET_EN bit (register 3, bit 8) is set to 1, the offset value to be subtracted from the odd sample of ADC2 can be obtained with this 10-bit register. The offset value is in twos complement format and its LSB corresponds to a 14-bit LSB. |

12.1.1.14 Register 10h (address = 10h)

图 110. Register 10h

| | | | | | | | |
|--------------|----|----|----|----|--------|--------------|---|
| 15 | 14 | 13 | 12 | 11 | 10 | 9 | 8 |
| GAIN_ADC2e | | | | | 0 | OFFSET_ADC2e | |
| R/W-0h | | | | | R/W-0h | R/W-0h | |
| 7 | 6 | 5 | 4 | 3 | 2 | 1 | 0 |
| OFFSET_ADC2e | | | | | | | |
| R/W-0h | | | | | | | |

LEGEND: R/W = Read/Write; -n = value after reset

表 63. Register 10h Field Descriptions

| Bit | Field | Type | Reset | Description |
|-------|--------------|------|-------|--|
| 15-11 | GAIN_ADC2e | R/W | 0h | When the DIG_GAIN_EN bit (register 3, bit 12) is set to 1, the digital gain value for the even sample of ADC2 can be obtained with this register. For a value of N (decimal equivalent of binary) written to these bits, the digital gain gets set to $N \times 0.2$ dB. |
| 10 | 0 | R/W | 0h | Must write 0 |
| 9-0 | OFFSET_ADC2e | R/W | 0h | When the DIG_OFFSET_EN bit (register 3, bit 8) is set to 1, the offset value to be subtracted from the even sample of ADC2 can be obtained with this 10-bit register. The offset value is in twos complement format and its LSB corresponds to a 14-bit LSB. |

12.1.1.15 Register 11h (address = 11h)
图 111. Register 11h

| | | | | | | | |
|--------------|----|----|----|----|--------|--------------|---|
| 15 | 14 | 13 | 12 | 11 | 10 | 9 | 8 |
| GAIN_ADC3o | | | | | 0 | OFFSET_ADC3o | |
| R/W-0h | | | | | R/W-0h | R/W-0h | |
| 7 | 6 | 5 | 4 | 3 | 2 | 1 | 0 |
| OFFSET_ADC3o | | | | | | | |
| R/W-0h | | | | | | | |

LEGEND: R/W = Read/Write; -n = value after reset

表 64. Register 11h Field Descriptions

| Bit | Field | Type | Reset | Description |
|-------|--------------|------|-------|---|
| 15-11 | GAIN_ADC3o | R/W | 0h | When the DIG_GAIN_EN bit (register 3, bit 12) is set to 1, the digital gain value for the odd sample of ADC3 can be obtained with this register. For a value of N (decimal equivalent of binary) written to these bits, the digital gain gets set to $N \times 0.2$ dB. |
| 10 | 0 | R/W | 0h | Must write 0 |
| 9-0 | OFFSET_ADC3o | R/W | 0h | When the DIG_OFFSET_EN bit (register 3, bit 8) is set to 1, the offset value to be subtracted from the odd sample of ADC3 can be obtained with this 10-bit register. The offset value is in twos complement format and its LSB corresponds to a 14-bit LSB. |

12.1.1.16 Register 12h (address = 12h)
图 112. Register 12h

| | | | | | | | |
|--------------|----|----|----|----|--------|--------------|---|
| 15 | 14 | 13 | 12 | 11 | 10 | 9 | 8 |
| GAIN_ADC3e | | | | | 0 | OFFSET_ADC3e | |
| R/W-0h | | | | | R/W-0h | R/W-0h | |
| 7 | 6 | 5 | 4 | 3 | 2 | 1 | 0 |
| OFFSET_ADC3e | | | | | | | |
| R/W-0h | | | | | | | |

LEGEND: R/W = Read/Write; -n = value after reset

表 65. Register 12h Field Descriptions

| Bit | Field | Type | Reset | Description |
|-------|--------------|------|-------|--|
| 15-11 | GAIN_ADC3e | R/W | 0h | When the DIG_GAIN_EN bit (register 3, bit 12) is set to 1, the digital gain value for the even sample of ADC3 can be obtained with this register. For a value of N (decimal equivalent of binary) written to these bits, the digital gain gets set to $N \times 0.2$ dB. |
| 10 | 0 | R/W | 0h | Must write 0 |
| 9-0 | OFFSET_ADC3e | R/W | 0h | When the DIG_OFFSET_EN bit (register 3, bit 8) is set to 1, the offset value to be subtracted from the even sample of ADC3 can be obtained with this 10-bit register. The offset value is in twos complement format and its LSB corresponds to a 14-bit LSB. |

12.1.1.17 Register 13h (address = 13h)

图 113. Register 13h

| | | | | | | | |
|--------------|----|----|----|----|--------|--------------|---|
| 15 | 14 | 13 | 12 | 11 | 10 | 9 | 8 |
| GAIN_ADC4o | | | | | 0 | OFFSET_ADC4o | |
| R/W-0h | | | | | R/W-0h | R/W-0h | |
| 7 | 6 | 5 | 4 | 3 | 2 | 1 | 0 |
| OFFSET_ADC4o | | | | | | | |
| R/W-0h | | | | | | | |

LEGEND: R/W = Read/Write; -n = value after reset

表 66. Register 13h Field Descriptions

| Bit | Field | Type | Reset | Description |
|-------|--------------|------|-------|---|
| 15-11 | GAIN_ADC4o | R/W | 0h | When the DIG_GAIN_EN bit (register 3, bit 12) is set to 1, the digital gain value for the odd sample of ADC4 can be obtained with this register. For a value of N (decimal equivalent of binary) written to these bits, the digital gain gets set to $N \times 0.2$ dB. |
| 10 | 0 | R/W | 0h | Must write 0 |
| 9-0 | OFFSET_ADC4o | R/W | 0h | When the DIG_OFFSET_EN bit (register 3, bit 8) is set to 1, the offset value to be subtracted from the odd sample of ADC4 can be obtained with this 10-bit register. The offset value is in twos complement format and its LSB corresponds to a 14-bit LSB. |

12.1.1.18 Register 14h (address = 14h)

图 114. Register 14h

| | | | | | | | |
|--------------|----|----|----|----|--------|--------------|---|
| 15 | 14 | 13 | 12 | 11 | 10 | 9 | 8 |
| GAIN_ADC4e | | | | | 0 | OFFSET_ADC4e | |
| R/W-0h | | | | | R/W-0h | R/W-0h | |
| 7 | 6 | 5 | 4 | 3 | 2 | 1 | 0 |
| OFFSET_ADC4e | | | | | | | |
| R/W-0h | | | | | | | |

LEGEND: R/W = Read/Write; -n = value after reset

表 67. Register 14h Field Descriptions

| Bit | Field | Type | Reset | Description |
|-------|--------------|------|-------|--|
| 15-11 | GAIN_ADC4e | R/W | 0h | When the DIG_GAIN_EN bit (register 3, bit 12) is set to 1, the digital gain value for the even sample of ADC4 can be obtained with this register. For a value of N (decimal equivalent of binary) written to these bits, the digital gain gets set to $N \times 0.2$ dB. |
| 10 | 0 | R/W | 0h | Must write 0 |
| 9-0 | OFFSET_ADC4e | R/W | 0h | When the DIG_OFFSET_EN bit (register 3, bit 8) is set to 1, the offset value to be subtracted from the even sample of ADC4 can be obtained with this 10-bit register. The offset value is in twos complement format and its LSB corresponds to a 14-bit LSB. |

12.1.1.19 Register 15h (address = 15h)
图 115. Register 15h

| | | | | | | | | | | | | | | | |
|----------------|--|--------------------|--|-------------------|--|----------------|--|-------------------|--|----|--|-----------|--|---|--|
| 15 | | 14 | | 13 | | 12 | | 11 | | 10 | | 9 | | 8 | |
| PAT_PRBS_LVDS1 | | PAT_PRBS_LVDS2 | | PAT_PRBS_LVDS3 | | PAT_PRBS_LVDS4 | | PAT_LVDS1 | | | | PAT_LVDS2 | | | |
| R/W-0h | | R/W-0h | | R/W-0h | | R/W-0h | | R/W-0h | | | | R/W-0h | | | |
| 7 | | 6 | | 5 | | 4 | | 3 | | 2 | | 1 | | 0 | |
| PAT_LVDS2 | | HPF_ROUND_EN_CH1-8 | | HPF_CORNER_ADC1-4 | | | | DIG_HPF_EN_ADC1-4 | | | | | | | |
| R/W-0h | | R/W-0h | | R/W-0h | | | | R/W-0h | | | | | | | |

LEGEND: R/W = Read/Write; -n = value after reset

表 68. Register 15h Field Descriptions

| Bit | Field | Type | Reset | Description |
|------|--------------------|------|-------|--|
| 15 | PAT_PRBS_LVDS1 | R/W | 0h | When the PAT_SELECT_IND bit (register 4, bit 8) is set to 1, the PRBS pattern on LVDS output 1 can be enabled with this bit; see the LVDS Test Pattern Mode section for further details. |
| 14 | PAT_PRBS_LVDS2 | R/W | 0h | When the PAT_SELECT_IND bit (register 4, bit 8) is set to 1, the PRBS pattern on LVDS output 2 can be enabled with this bit; see the LVDS Test Pattern Mode section for further details. |
| 13 | PAT_PRBS_LVDS3 | R/W | 0h | When the PAT_SELECT_IND bit (register 4, bit 8) is set to 1, the PRBS pattern on LVDS output 3 can be enabled with this bit; see the LVDS Test Pattern Mode section for further details. |
| 12 | PAT_PRBS_LVDS4 | R/W | 0h | When the PAT_SELECT_IND bit (register 4, bit 8) is set to 1, the PRBS pattern on LVDS output 4 can be enabled with this bit; see the LVDS Test Pattern Mode section for further details. |
| 11-9 | PAT_LVDS1 | R/W | 0h | When the PAT_SELECT_IND bit (register 4, bit 8) is set to 1, the pattern on LVDS output 1 can be programmed with these bits; see 表 33 for bit descriptions. |
| 8-6 | PAT_LVDS2 | R/W | 0h | When the PAT_SELECT_IND bit (register 4, bit 8) is set to 1, the pattern on LVDS output 2 can be programmed with these bits; see 表 33 for bit descriptions. |
| 5 | HPF_ROUND_EN_CH1-8 | R/W | 0h | 0 = Rounding in the ADC HPF is disabled for channel 1 to 8. HPF output is truncated to be mapped to the ADC resolution bits. 1 = HPF output of channel 1 to 8 is mapped to the ADC resolution bits by the round-off operation. |
| 4-1 | HPF_CORNER_ADC1-4 | R/W | 0h | When the DIG_HPF_EN_ADC1-4 bit is set to 1, the digital HPF characteristic for the corresponding ADCs can be programmed by setting the value of k with these bits. The value of k can be from 2 to 10 (0010b to 1010b); see the Digital HPF section for further details. |
| 0 | DIG_HPF_EN_ADC1-4 | R/W | 0h | 0 = Digital HPF disabled for ADCs 1 to 4 (default) 1 = Enables digital HPF for ADCs 1 to 4 |

12.1.1.20 Register 17h (address = 17h)
图 116. Register 17h

| | | | | | | | |
|-----------|--------|--------|-----------|------------------|------------------|------------------|------------------|
| 15 | 14 | 13 | 12 | 11 | 10 | 9 | 8 |
| 0 | 0 | 0 | 0 | IN_16CH_ ADC1 | IN_16CH_ ADC2 | IN_16CH_ ADC3 | IN_16CH_ ADC4 |
| R/W-0h | R/W-0h | R/W-0h | R/W-0h | R/W-0h | R/W-0h | R/W-0h | R/W-0h |
| 7 | 6 | 5 | 4 | 3 | 2 | 1 | 0 |
| PAT_LVDS3 | | | PAT_LVDS4 | | | 0 | 0 |
| R/W-0h | | | R/W-0h | | | R/W-0h | R/W-0h |

LEGEND: R/W = Read/Write; -n = value after reset

表 69. Register 17h Field Descriptions

| Bit | Field | Type | Reset | Description |
|-------|--------------|------|-------|---|
| 15-12 | 0 | R/W | 0h | Must write 0 |
| 11 | IN_16CH_ADC1 | R/W | 0h | Selects the input pair sampled by ADC1 in 16-input mode. 0 = ADC1 samples the signal on INP1, INM1 1 = ADC1 samples the signal on INP2, INM2 |
| 10 | IN_16CH_ADC2 | R/W | 0h | Selects the input pair sampled by ADC2 in 16-input mode. 0 = ADC2 samples the signal on INP3, INM3 1 = ADC2 samples the signal on INP4, INM4 |
| 9 | IN_16CH_ADC3 | R/W | 0h | Selects the input pair sampled by ADC3 in 16-input mode. 0 = ADC3 samples the signal on INP5, INM5 1 = ADC3 samples the signal on INP6, INM6 |
| 8 | IN_16CH_ADC4 | R/W | 0h | Selects the input pair sampled by ADC4 in 16-input mode. 0 = ADC4 samples the signal on INP7, INM7 1 = ADC4 samples the signal on INP8, INM8 |
| 7-5 | PAT_LVDS3 | R/W | 0h | When the PAT_SELECT_IND bit (register 4, bit 8) is set to 1, the pattern on LVDS output 3 can be programmed with these bits; see 表 33 for bit descriptions. |
| 4-2 | PAT_LVDS4 | R/W | 0h | When the PAT_SELECT_IND bit (register 4, bit 8) is set to 1, the pattern on LVDS output 4 can be programmed with these bits; see 表 33 for bit descriptions. |
| 1-0 | 0 | R/W | 0h | Must write 0 |

12.1.1.21 Register 18h (address = 18h)
图 117. Register 18h

| 15 | 14 | 13 | 12 | 11 | 10 | 9 | 8 |
|--------------|--------------|--------------|--------------|--------------|--------------|--------------|--------------|
| PDN_DIG_ADC4 | PDN_DIG_ADC3 | PDN_DIG_ADC2 | PDN_DIG_ADC1 | PDN_LVDS4 | PDN_LVDS3 | PDN_LVDS2 | PDN_LVDS1 |
| R/W-0h | R/W-0h | R/W-0h | R/W-0h | R/W-0h | R/W-0h | R/W-0h | R/W-0h |
| 7 | 6 | 5 | 4 | 3 | 2 | 1 | 0 |
| PDN_ANA_ADC4 | PDN_ANA_ADC3 | PDN_ANA_ADC2 | PDN_ANA_ADC1 | INVERT_LVDS4 | INVERT_LVDS3 | INVERT_LVDS2 | INVERT_LVDS1 |
| R/W-0h | R/W-0h | R/W-0h | R/W-0h | R/W-0h | R/W-0h | R/W-0h | R/W-0h |

LEGEND: R/W = Read/Write; -n = value after reset

表 70. Register 18h Field Descriptions

| Bit | Field | Type | Reset | Description |
|-----|--------------|------|-------|--|
| 15 | PDN_DIG_ADC4 | R/W | 0h | 0 = Normal operation (default) 1 = Powers down the digital block for ADC4 |
| 14 | PDN_DIG_ADC3 | R/W | 0h | 0 = Normal operation (default) 1 = Powers down the digital block for ADC3 |
| 13 | PDN_DIG_ADC2 | R/W | 0h | 0 = Normal operation (default) 1 = Powers down the digital block for ADC2 |
| 12 | PDN_DIG_ADC1 | R/W | 0h | 0 = Normal operation (default) 1 = Powers down the digital block for ADC1 |
| 11 | PDN_LVDS4 | R/W | 0h | 0 = Normal operation (default) 1 = Powers down LVDS output line 4 |
| 10 | PDN_LVDS3 | R/W | 0h | 0 = Normal operation (default) 1 = Powers down LVDS output line 3 |
| 9 | PDN_LVDS2 | R/W | 0h | 0 = Normal operation (default) 1 = Powers down LVDS output line 2 |
| 8 | PDN_LVDS1 | R/W | 0h | 0 = Normal operation (default) 1 = Powers down LVDS output line 1 |
| 7 | PDN_ANA_ADC4 | R/W | 0h | 0 = Normal operation (default) 1 = Powers down the analog block for ADC4 |
| 6 | PDN_ANA_ADC3 | R/W | 0h | 0 = Normal operation (default) 1 = Powers down the analog block for ADC3 |
| 5 | PDN_ANA_ADC2 | R/W | 0h | 0 = Normal operation (default) 1 = Powers down the analog block for ADC2 |
| 4 | PDN_ANA_ADC1 | R/W | 0h | 0 = Normal operation (default) 1 = Powers down the analog block for ADC1 |
| 3 | INVERT_LVDS4 | R/W | 0h | 0 = Normal operation (default) 1 = Inverts ADC data sent on LVDS output line 4. Has no effect on Test patterns. |
| 2 | INVERT_LVDS3 | R/W | 0h | 0 = Normal operation (default) 1 = Inverts ADC data sent on LVDS output line 3. Has no effect on Test patterns. |
| 1 | INVERT_LVDS2 | R/W | 0h | 0 = Normal operation (default) 1 = Inverts ADC data sent on LVDS output line 2. Has no effect on Test patterns. |
| 0 | INVERT_LVDS1 | R/W | 0h | 0 = Normal operation (default) 1 = Inverts ADC data sent on LVDS output line 1. Has no effect on Test patterns. |

12.1.1.22 Register 19h (address = 19h)

图 118. Register 19h

| | | | | | | | |
|--------------|----|----|----|----|--------|--------------|---|
| 15 | 14 | 13 | 12 | 11 | 10 | 9 | 8 |
| GAIN_ADC5o | | | | | 0 | OFFSET_ADC5o | |
| R/W-0h | | | | | R/W-0h | R/W-0h | |
| 7 | 6 | 5 | 4 | 3 | 2 | 1 | 0 |
| OFFSET_ADC5o | | | | | | | |
| R/W-0h | | | | | | | |

LEGEND: R/W = Read/Write; -n = value after reset

表 71. Register 19h Field Descriptions

| Bit | Field | Type | Reset | Description |
|-------|--------------|------|-------|--|
| 15-11 | GAIN_ADC5o | R/W | 0h | When the DIG_GAIN_EN bit (register 3, bit 12) is set to 1, the digital gain value for the odd sample of ADC5 can be obtained with this register. For a value of N (decimal equivalent of binary) written to these bits, the digital gain gets set to N × 0.2 dB. |
| 10 | 0 | R/W | 0h | Must write 0 |
| 9-0 | OFFSET_ADC5o | R/W | 0h | When the DIG_OFFSET_EN bit (register 3, bit 8) is set to 1, the offset value to be subtracted from the odd sample of ADC5 can be obtained with this 10-bit register. The offset value is in twos complement format and its LSB corresponds to a 14-bit LSB. |

12.1.1.23 Register 1Ah (address = 1Ah)

图 119. Register 1Ah

| | | | | | | | |
|--------------|----|----|----|----|--------|--------------|---|
| 15 | 14 | 13 | 12 | 11 | 10 | 9 | 8 |
| GAIN_ADC5e | | | | | 0 | OFFSET_ADC5e | |
| R/W-0h | | | | | R/W-0h | R/W-0h | |
| 7 | 6 | 5 | 4 | 3 | 2 | 1 | 0 |
| OFFSET_ADC5e | | | | | | | |
| R/W-0h | | | | | | | |

LEGEND: R/W = Read/Write; -n = value after reset

表 72. Register 1Ah Field Descriptions

| Bit | Field | Type | Reset | Description |
|-------|--------------|------|-------|---|
| 15-11 | GAIN_ADC5e | R/W | 0h | When the DIG_GAIN_EN bit (register 3, bit 12) is set to 1, the digital gain value for the even sample of ADC5 can be obtained with this register. For a value of N (decimal equivalent of binary) written to these bits, the digital gain gets set to N × 0.2 dB. |
| 10 | 0 | R/W | 0h | Must write 0 |
| 9-0 | OFFSET_ADC5e | R/W | 0h | When the DIG_OFFSET_EN bit (register 3, bit 8) is set to 1, the offset value to be subtracted from the even sample of ADC5 can be obtained with this 10-bit register. The offset value is in twos complement format and its LSB corresponds to a 14-bit LSB. |

12.1.1.24 Register 1Bh (address = 1Bh)

图 120. Register 1Bh

| | | | | | | | |
|--------------|----|----|----|----|--------|--------------|---|
| 15 | 14 | 13 | 12 | 11 | 10 | 9 | 8 |
| GAIN_ADC6o | | | | | 0 | OFFSET_ADC6o | |
| R/W-0h | | | | | R/W-0h | R/W-0h | |
| 7 | 6 | 5 | 4 | 3 | 2 | 1 | 0 |
| OFFSET_ADC6o | | | | | | | |
| R/W-0h | | | | | | | |

LEGEND: R/W = Read/Write; -n = value after reset

表 73. Register 1Bh Field Descriptions

| Bit | Field | Type | Reset | Description |
|-------|--------------|------|-------|---|
| 15-11 | GAIN_ADC6o | R/W | 0h | When the DIG_GAIN_EN bit (register 3, bit 12) is set to 1, the digital gain value for the odd sample of ADC6 can be obtained with this register. For a value of N (decimal equivalent of binary) written to these bits, the digital gain gets set to $N \times 0.2$ dB. |
| 10 | 0 | R/W | 0h | Must write 0 |
| 9-0 | OFFSET_ADC6o | R/W | 0h | When the DIG_OFFSET_EN bit (register 3, bit 8) is set to 1, the offset value to be subtracted from the odd sample of ADC6 can be obtained with this 10-bit register. The offset value is in twos complement format and its LSB corresponds to a 14-bit LSB. |

12.1.1.25 Register 1Ch (address = 1Ch)

图 121. Register 1Ch

| | | | | | | | |
|--------------|----|----|----|----|--------|--------------|---|
| 15 | 14 | 13 | 12 | 11 | 10 | 9 | 8 |
| GAIN_ADC6e | | | | | 0 | OFFSET_ADC6e | |
| R/W-0h | | | | | R/W-0h | R/W-0h | |
| 7 | 6 | 5 | 4 | 3 | 2 | 1 | 0 |
| OFFSET_ADC6e | | | | | | | |
| R/W-0h | | | | | | | |

LEGEND: R/W = Read/Write; -n = value after reset

表 74. Register 1Ch Field Descriptions

| Bit | Field | Type | Reset | Description |
|-------|--------------|------|-------|--|
| 15-11 | GAIN_ADC6e | R/W | 0h | When the DIG_GAIN_EN bit (register 3, bit 12) is set to 1, the digital gain value for the even sample of ADC6 can be obtained with this register. For a value of N (decimal equivalent of binary) written to these bits, the digital gain gets set to $N \times 0.2$ dB. |
| 10 | 0 | R/W | 0h | Must write 0 |
| 9-0 | OFFSET_ADC6e | R/W | 0h | When the DIG_OFFSET_EN bit (register 3, bit 8) is set to 1, the offset value to be subtracted from the even sample of ADC6 can be obtained with this 10-bit register. The offset value is in twos complement format and its LSB corresponds to a 14-bit LSB. |

12.1.1.26 Register 1Dh (address = 1Dh)

图 122. Register 1Dh

| | | | | | | | |
|--------------|----|----|----|----|--------|--------------|---|
| 15 | 14 | 13 | 12 | 11 | 10 | 9 | 8 |
| GAIN_ADC7o | | | | | 0 | OFFSET_ADC7o | |
| R/W-0h | | | | | R/W-0h | R/W-0h | |
| 7 | 6 | 5 | 4 | 3 | 2 | 1 | 0 |
| OFFSET_ADC7o | | | | | | | |
| R/W-0h | | | | | | | |

LEGEND: R/W = Read/Write; -n = value after reset

表 75. Register 1Dh Field Descriptions

| Bit | Field | Type | Reset | Description |
|-------|--------------|------|-------|--|
| 15-11 | GAIN_ADC7o | R/W | 0h | When the DIG_GAIN_EN bit (register 3, bit 12) is set to 1, the digital gain value for the odd sample of ADC7 can be obtained with this register. For a value of N (decimal equivalent of binary) written to these bits, the digital gain gets set to N × 0.2 dB. |
| 10 | 0 | R/W | 0h | Must write 0 |
| 9-0 | OFFSET_ADC7o | R/W | 0h | When the DIG_OFFSET_EN bit (register 3, bit 8) is set to 1, the offset value to be subtracted from the odd sample of ADC7 can be obtained with this 10-bit register. The offset value is in twos complement format and its LSB corresponds to a 14-bit LSB. |

12.1.1.27 Register 1Eh (address = 1Eh)

图 123. Register 1Eh

| | | | | | | | |
|--------------|----|----|----|----|--------|--------------|---|
| 15 | 14 | 13 | 12 | 11 | 10 | 9 | 8 |
| GAIN_ADC7e | | | | | 0 | OFFSET_ADC7e | |
| R/W-0h | | | | | R/W-0h | R/W-0h | |
| 7 | 6 | 5 | 4 | 3 | 2 | 1 | 0 |
| OFFSET_ADC7e | | | | | | | |
| R/W-0h | | | | | | | |

LEGEND: R/W = Read/Write; -n = value after reset

表 76. Register 1Eh Field Descriptions

| Bit | Field | Type | Reset | Description |
|-------|--------------|------|-------|---|
| 15-11 | GAIN_ADC7e | R/W | 0h | When the DIG_GAIN_EN bit (register 3, bit 12) is set to 1, the digital gain value for the even sample of ADC7 can be obtained with this register. For a value of N (decimal equivalent of binary) written to these bits, the digital gain gets set to N × 0.2 dB. |
| 10 | 0 | R/W | 0h | Must write 0 |
| 9-0 | OFFSET_ADC7e | R/W | 0h | When the DIG_OFFSET_EN bit (register 3, bit 8) is set to 1, the offset value to be subtracted from the even sample of ADC7 can be obtained with this 10-bit register. The offset value is in twos complement format and its LSB corresponds to a 14-bit LSB. |

12.1.1.28 Register 1Fh (address = 1Fh)
图 124. Register 1Fh

| | | | | | | | |
|--------------|----|----|----|----|--------|--------------|---|
| 15 | 14 | 13 | 12 | 11 | 10 | 9 | 8 |
| GAIN_ADC8o | | | | | 0 | OFFSET_ADC8o | |
| R/W-0h | | | | | R/W-0h | R/W-0h | |
| 7 | 6 | 5 | 4 | 3 | 2 | 1 | 0 |
| OFFSET_ADC8o | | | | | | | |
| R/W-0h | | | | | | | |

LEGEND: R/W = Read/Write; -n = value after reset

表 77. Register 1Fh Field Descriptions

| Bit | Field | Type | Reset | Description |
|-------|--------------|------|-------|---|
| 15-11 | GAIN_ADC8o | R/W | 0h | When the DIG_GAIN_EN bit (register 3, bit 12) is set to 1, the digital gain value for the odd sample of ADC8 can be obtained with this register. For a value of N (decimal equivalent of binary) written to these bits, the digital gain gets set to $N \times 0.2$ dB. |
| 10 | 0 | R/W | 0h | Must write 0 |
| 9-0 | OFFSET_ADC8o | R/W | 0h | When the DIG_OFFSET_EN bit (register 3, bit 8) is set to 1, the offset value to be subtracted from the odd sample of ADC8 can be obtained with this 10-bit register. The offset value is in twos complement format and its LSB corresponds to a 14-bit LSB. |

12.1.1.29 Register 20h (address = 20h)
图 125. Register 20h

| | | | | | | | |
|--------------|----|----|----|----|--------|--------------|---|
| 15 | 14 | 13 | 12 | 11 | 10 | 9 | 8 |
| GAIN_ADC8e | | | | | 0 | OFFSET_ADC8e | |
| R/W-0h | | | | | R/W-0h | R/W-0h | |
| 7 | 6 | 5 | 4 | 3 | 2 | 1 | 0 |
| OFFSET_ADC8e | | | | | | | |
| R/W-0h | | | | | | | |

LEGEND: R/W = Read/Write; -n = value after reset

表 78. Register 20h Field Descriptions

| Bit | Field | Type | Reset | Description |
|-------|--------------|------|-------|--|
| 15-11 | GAIN_ADC8e | R/W | 0h | When the DIG_GAIN_EN bit (register 3, bit 12) is set to 1, the digital gain value for the even sample of ADC8 can be obtained with this register. For a value of N (decimal equivalent of binary) written to these bits, the digital gain gets set to $N \times 0.2$ dB. |
| 10 | 0 | R/W | 0h | Must write 0 |
| 9-0 | OFFSET_ADC8e | R/W | 0h | When the DIG_OFFSET_EN bit (register 3, bit 8) is set to 1, the offset value to be subtracted from the even sample of ADC8 can be obtained with this 10-bit register. The offset value is in twos complement format and its LSB corresponds to a 14-bit LSB. |

12.1.1.30 Register 21h (offset = 21h)
图 126. Register 21h

| | | | | | | | | | | | | | | | |
|----------------|--|----------------|--|----------------|--|-------------------|--|-----------|--|----|--|-------------------|--|---|--|
| 15 | | 14 | | 13 | | 12 | | 11 | | 10 | | 9 | | 8 | |
| PAT_PRBS_LVDS5 | | PAT_PRBS_LVDS6 | | PAT_PRBS_LVDS7 | | PAT_PRBS_LVDS8 | | PAT_LVDS5 | | | | PAT_LVDS6 | | | |
| R/W-0h | | R/W-0h | | R/W-0h | | R/W-0h | | R/W-0h | | | | R/W-0h | | | |
| 7 | | 6 | | 5 | | 4 | | 3 | | 2 | | 1 | | 0 | |
| PAT_LVDS6 | | | | 0 | | HPF_CORNER_ADC5-8 | | | | | | DIG_HPF_EN_ADC5-8 | | | |
| R/W-0h | | | | R/W-0h | | R/W-0h | | | | | | R/W-0h | | | |

LEGEND: R/W = Read/Write; -n = value after reset

表 79. Register 21h Field Descriptions

| Bit | Field | Type | Reset | Description |
|------|-------------------|------|-------|--|
| 15 | PAT_PRBS_LVDS5 | R/W | 0h | When the PAT_SELECT_IND bit (register 4, bit 8) is set to 1, the PRBS pattern on LVDS output 5 can be enabled with this bit; see the LVDS Test Pattern Mode section for further details. |
| 14 | PAT_PRBS_LVDS6 | R/W | 0h | When the PAT_SELECT_IND bit (register 4, bit 8) is set to 1, the PRBS pattern on LVDS output 6 can be enabled with this bit; see the LVDS Test Pattern Mode section for further details. |
| 13 | PAT_PRBS_LVDS7 | R/W | 0h | When the PAT_SELECT_IND bit (register 4, bit 8) is set to 1, the PRBS pattern on LVDS output 7 can be enabled with this bit; see the LVDS Test Pattern Mode section for further details. |
| 12 | PAT_PRBS_LVDS8 | R/W | 0h | When the PAT_SELECT_IND bit (register 4, bit 8) is set to 1, the PRBS pattern on LVDS output 8 can be enabled with this bit; see the LVDS Test Pattern Mode section for further details. |
| 11-9 | PAT_LVDS5 | R/W | 0h | When the PAT_SELECT_IND bit (register 4, bit 8) is set to 1, the pattern on LVDS output 5 can be programmed with these bits; see 表 33 for bit descriptions. |
| 8-6 | PAT_LVDS6 | R/W | 0h | When the PAT_SELECT_IND bit (register 4, bit 8) is set to 1, the pattern on LVDS output 6 can be programmed with these bits; see 表 33 for bit descriptions. |
| 5 | 0 | R/W | 0h | Must write 0 |
| 4-1 | HPF_CORNER_ADC5-8 | R/W | 0h | When the DIG_HPF_EN_ADC5-8 bit is set to 1, the digital HPF characteristic for the corresponding ADCs can be programmed by setting the value of k with these bits. The value of k can be from 2 to 10 (0010b to 1010b); see the Digital HPF section for further details. |
| 0 | DIG_HPF_EN_ADC5-8 | R/W | 0h | 0 = Digital HPF disabled for ADCs 5 to 8 (default) 1 = Enables digital HPF for ADCs 5 to 8 |

12.1.1.31 Register 23h (register = 23h)
图 127. Register 23h

| | | | | | | | |
|-----------|--------|--------|-----------|------------------|------------------|------------------|------------------|
| 15 | 14 | 13 | 12 | 11 | 10 | 9 | 8 |
| 0 | 0 | 0 | 0 | IN_16CH_ ADC5 | IN_16CH_ ADC6 | IN_16CH_ ADC7 | IN_16CH_ ADC8 |
| R/W-0h | R/W-0h | R/W-0h | R/W-0h | R/W-0h | R/W-0h | R/W-0h | R/W-0h |
| 7 | 6 | 5 | 4 | 3 | 2 | 1 | 0 |
| PAT_LVDS7 | | | PAT_LVDS8 | | | 0 | 0 |
| R/W-0h | | | R/W-0h | | | R/W-0h | R/W-0h |

LEGEND: R/W = Read/Write; -n = value after reset

表 80. Register 23h Field Descriptions

| Bit | Field | Type | Reset | Description |
|-------|--------------|------|-------|---|
| 15-12 | 0 | R/W | 0h | Must write 0 |
| 11 | IN_16CH_ADC5 | R/W | 0h | Selects the input pair sampled by ADC5 in 16-input mode. 0 = ADC5 samples the signal on INP9, INM9 1 = ADC5 samples the signal on INP10, INM10 |
| 10 | IN_16CH_ADC6 | R/W | 0h | Selects the input pair sampled by ADC6 in 16-input mode. 0 = ADC6 samples the signal on INP11, INM11 1 = ADC6 samples the signal on INP12, INM12 |
| 9 | IN_16CH_ADC7 | R/W | 0h | Selects the input pair sampled by ADC7 in 16-input mode. 0 = ADC7 samples the signal on INP13, INM13 1 = ADC7 samples the signal on INP14, INM14 |
| 8 | IN_16CH_ADC8 | R/W | 0h | Selects the input pair sampled by ADC8 in 16-input mode. 0 = ADC8 samples the signal on INP15, INM15 1 = ADC8 samples the signal on INP16, INM16 |
| 7-5 | PAT_LVDS7 | R/W | 0h | When the PAT_SELECT_IND bit (register 4, bit 8) is set to 1, the pattern on LVDS output 7 can be programmed with these bits; see 表 33 for bit descriptions. |
| 4-2 | PAT_LVDS8 | R/W | 0h | When the PAT_SELECT_IND bit (register 4, bit 8) is set to 1, the pattern on LVDS output 8 can be programmed with these bits; see 表 33 for bit descriptions. |
| 1-0 | 0 | R/W | 0h | Must write 0 |

12.1.1.32 Register 24h (address = 24h)
图 128. Register 24h

| 15 | 14 | 13 | 12 | 11 | 10 | 9 | 8 |
|--------------|--------------|--------------|--------------|--------------|--------------|--------------|--------------|
| PDN_DIG_ADC8 | PDN_DIG_ADC7 | PDN_DIG_ADC6 | PDN_DIG_ADC5 | PDN_LVDS8 | PDN_LVDS7 | PDN_LVDS6 | PDN_LVDS5 |
| R/W-0h | R/W-0h | R/W-0h | R/W-0h | R/W-0h | R/W-0h | R/W-0h | R/W-0h |
| 7 | 6 | 5 | 4 | 3 | 2 | 1 | 0 |
| PDN_ANA_ADC8 | PDN_ANA_ADC7 | PDN_ANA_ADC6 | PDN_ANA_ADC5 | INVERT_LVDS8 | INVERT_LVDS7 | INVERT_LVDS6 | INVERT_LVDS5 |
| R/W-0h | R/W-0h | R/W-0h | R/W-0h | R/W-0h | R/W-0h | R/W-0h | R/W-0h |

LEGEND: R/W = Read/Write; -n = value after reset

表 81. Register 24h Field Descriptions

| Bit | Field | Type | Reset | Description |
|-----|--------------|------|-------|--|
| 15 | PDN_DIG_ADC8 | R/W | 0h | 0 = Normal operation (default) 1 = Powers down the digital block for ADC8 |
| 14 | PDN_DIG_ADC7 | R/W | 0h | 0 = Normal operation (default) 1 = Powers down the digital block for ADC7 |
| 13 | PDN_DIG_ADC6 | R/W | 0h | 0 = Normal operation (default) 1 = Powers down the digital block for ADC6 |
| 12 | PDN_DIG_ADC5 | R/W | 0h | 0 = Normal operation (default) 1 = Powers down the digital block for ADC5 |
| 11 | PDN_LVDS8 | R/W | 0h | 0 = Normal operation (default) 1 = Powers down LVDS output line 8 |
| 10 | PDN_LVDS7 | R/W | 0h | 0 = Normal operation (default) 1 = Powers down LVDS output line 7 |
| 9 | PDN_LVDS6 | R/W | 0h | 0 = Normal operation (default) 1 = Powers down LVDS output line 6 |
| 8 | PDN_LVDS5 | R/W | 0h | 0 = Normal operation (default) 1 = Powers down LVDS output line 5 |
| 7 | PDN_ANA_ADC8 | R/W | 0h | 0 = Normal operation (default) 1 = Powers down the analog block for ADC8 |
| 6 | PDN_ANA_ADC7 | R/W | 0h | 0 = Normal operation (default) 1 = Powers down the analog block for ADC7 |
| 5 | PDN_ANA_ADC6 | R/W | 0h | 0 = Normal operation (default) 1 = Powers down the analog block for ADC6 |
| 4 | PDN_ANA_ADC5 | R/W | 0h | 0 = Normal operation (default) 1 = Powers down the analog block for ADC5 |
| 3 | INVERT_LVDS8 | R/W | 0h | 0 = Normal operation (default) 1 = Inverts ADC data sent on LVDS output line 8. Has no effect on Test patterns. |
| 2 | INVERT_LVDS7 | R/W | 0h | 0 = Normal operation (default) 1 = Inverts ADC data sent on LVDS output line 7. Has no effect on Test patterns. |
| 1 | INVERT_LVDS6 | R/W | 0h | 0 = Normal operation (default) 1 = Inverts ADC data sent on LVDS output line 6. Has no effect on Test patterns. |
| 0 | INVERT_LVDS5 | R/W | 0h | 0 = Normal operation (default) 1 = Inverts ADC data sent on LVDS output line 5. Has no effect on Test patterns. |

12.1.1.33 Register 25h (address = 25h)
图 129. Register 25h

| | | | | | | | |
|--------------|----|----|----|----|--------|--------------|---|
| 15 | 14 | 13 | 12 | 11 | 10 | 9 | 8 |
| GAIN_ADC9o | | | | | 0 | OFFSET_ADC9o | |
| R/W-0h | | | | | R/W-0h | R/W-0h | |
| 7 | 6 | 5 | 4 | 3 | 2 | 1 | 0 |
| OFFSET_ADC9o | | | | | | | |
| R/W-0h | | | | | | | |

LEGEND: R/W = Read/Write; -n = value after reset

表 82. Register 25h Field Descriptions

| Bit | Field | Type | Reset | Description |
|-------|--------------|------|-------|---|
| 15-11 | GAIN_ADC9o | R/W | 0h | When the DIG_GAIN_EN bit (register 3, bit 12) is set to 1, the digital gain value for the odd sample of ADC9 can be obtained with this register. For a value of N (decimal equivalent of binary) written to these bits, the digital gain gets set to $N \times 0.2$ dB. |
| 10 | 0 | R/W | 0h | Must write 0 |
| 9-0 | OFFSET_ADC9o | R/W | 0h | When the DIG_OFFSET_EN bit (register 3, bit 8) is set to 1, the offset value to be subtracted from the odd sample of ADC9 can be obtained with this 10-bit register. The offset value is in twos complement format and its LSB corresponds to a 14-bit LSB. |

12.1.1.34 Register 26h (address = 26h)
图 130. Register 26h

| | | | | | | | |
|--------------|----|----|----|----|--------|--------------|---|
| 15 | 14 | 13 | 12 | 11 | 10 | 9 | 8 |
| GAIN_ADC9e | | | | | 0 | OFFSET_ADC9e | |
| R/W-0h | | | | | R/W-0h | R/W-0h | |
| 7 | 6 | 5 | 4 | 3 | 2 | 1 | 0 |
| OFFSET_ADC9e | | | | | | | |
| R/W-0h | | | | | | | |

LEGEND: R/W = Read/Write; -n = value after reset

表 83. Register 26h Field Descriptions

| Bit | Field | Type | Reset | Description |
|-------|--------------|------|-------|--|
| 15-11 | GAIN_ADC9e | R/W | 0h | When the DIG_GAIN_EN bit (register 3, bit 12) is set to 1, the digital gain value for the even sample of ADC9 can be obtained with this register. For a value of N (decimal equivalent of binary) written to these bits, the digital gain gets set to $N \times 0.2$ dB. |
| 10 | 0 | R/W | 0h | Must write 0 |
| 9-0 | OFFSET_ADC9e | R/W | 0h | When the DIG_OFFSET_EN bit (register 3, bit 8) is set to 1, the offset value to be subtracted from the even sample of ADC9 can be obtained with this 10-bit register. The offset value is in twos complement format and its LSB corresponds to a 14-bit LSB. |

12.1.1.35 Register 27h (address = 27h)

图 131. Register 27h

| | | | | | | | |
|---------------|----|----|----|----|--------|---------------|---|
| 15 | 14 | 13 | 12 | 11 | 10 | 9 | 8 |
| GAIN_ADC10o | | | | | 0 | OFFSET_ADC10o | |
| R/W-0h | | | | | R/W-0h | R/W-0h | |
| 7 | 6 | 5 | 4 | 3 | 2 | 1 | 0 |
| OFFSET_ADC10o | | | | | | | |
| R/W-0h | | | | | | | |

LEGEND: R/W = Read/Write; -n = value after reset

表 84. Register 27h Field Descriptions

| Bit | Field | Type | Reset | Description |
|-------|---------------|------|-------|---|
| 15-11 | GAIN_ADC10o | R/W | 0h | When the DIG_GAIN_EN bit (register 3, bit 12) is set to 1, the digital gain value for the odd sample of ADC10 can be obtained with this register. For a value of N (decimal equivalent of binary) written to these bits, the digital gain gets set to N × 0.2 dB. |
| 10 | 0 | R/W | 0h | Must write 0 |
| 9-0 | OFFSET_ADC10o | R/W | 0h | When the DIG_OFFSET_EN bit (register 3, bit 8) is set to 1, the offset value to be subtracted from the odd sample of ADC10 can be obtained with this 10-bit register. The offset value is in twos complement format and its LSB corresponds to a 14-bit LSB. |

12.1.1.36 Register 28h (address = 28h)

图 132. Register 28h

| | | | | | | | |
|---------------|----|----|----|----|--------|---------------|---|
| 15 | 14 | 13 | 12 | 11 | 10 | 9 | 8 |
| GAIN_ADC10e | | | | | 0 | OFFSET_ADC10e | |
| R/W-0h | | | | | R/W-0h | R/W-0h | |
| 7 | 6 | 5 | 4 | 3 | 2 | 1 | 0 |
| OFFSET_ADC10e | | | | | | | |
| R/W-0h | | | | | | | |

LEGEND: R/W = Read/Write; -n = value after reset

表 85. Register 28h Field Descriptions

| Bit | Field | Type | Reset | Description |
|-------|---------------|------|-------|--|
| 15-11 | GAIN_ADC10e | R/W | 0h | When the DIG_GAIN_EN bit (register 3, bit 12) is set to 1, the digital gain value for the even sample of ADC10 can be obtained with this register. For a value of N (decimal equivalent of binary) written to these bits, the digital gain gets set to N × 0.2 dB. |
| 10 | 0 | R/W | 0h | Must write 0 |
| 9-0 | OFFSET_ADC10e | R/W | 0h | When the DIG_OFFSET_EN bit (register 3, bit 8) is set to 1, the offset value to be subtracted from the even sample of ADC10 can be obtained with this 10-bit register. The offset value is in twos complement format and its LSB corresponds to a 14-bit LSB. |

12.1.1.37 Register 29h (address = 29h)
图 133. Register 29h

| | | | | | | | |
|---------------|----|----|----|----|--------|---------------|---|
| 15 | 14 | 13 | 12 | 11 | 10 | 9 | 8 |
| GAIN_ADC11o | | | | | 0 | OFFSET_ADC11o | |
| R/W-0h | | | | | R/W-0h | R/W-0h | |
| 7 | 6 | 5 | 4 | 3 | 2 | 1 | 0 |
| OFFSET_ADC11o | | | | | | | |
| R/W-0h | | | | | | | |

LEGEND: R/W = Read/Write; -n = value after reset

表 86. Register 29h Field Descriptions

| Bit | Field | Type | Reset | Description |
|-------|---------------|------|-------|--|
| 15-11 | GAIN_ADC11o | R/W | 0h | When the DIG_GAIN_EN bit (register 3, bit 12) is set to 1, the digital gain value for the odd sample of ADC11 can be obtained with this register. For a value of N (decimal equivalent of binary) written to these bits, the digital gain gets set to $N \times 0.2$ dB. |
| 10 | 0 | R/W | 0h | Must write 0 |
| 9-0 | OFFSET_ADC11o | R/W | 0h | When the DIG_OFFSET_EN bit (register 3, bit 8) is set to 1, the offset value to be subtracted from the odd sample of ADC11 can be obtained with this 10-bit register. The offset value is in twos complement format and its LSB corresponds to a 14-bit LSB. |

12.1.1.38 Register 2Ah (address = 2Ah)
图 134. Register 2Ah

| | | | | | | | |
|---------------|----|----|----|----|--------|---------------|---|
| 15 | 14 | 13 | 12 | 11 | 10 | 9 | 8 |
| GAIN_ADC11e | | | | | 0 | OFFSET_ADC11e | |
| R/W-0h | | | | | R/W-0h | R/W-0h | |
| 7 | 6 | 5 | 4 | 3 | 2 | 1 | 0 |
| OFFSET_ADC11e | | | | | | | |
| R/W-0h | | | | | | | |

LEGEND: R/W = Read/Write; -n = value after reset

表 87. Register 2Ah Field Descriptions

| Bit | Field | Type | Reset | Description |
|-------|---------------|------|-------|---|
| 15-11 | GAIN_ADC11e | R/W | 0h | When the DIG_GAIN_EN bit (register 3, bit 12) is set to 1, the digital gain value for the even sample of ADC11 can be obtained with this register. For a value of N (decimal equivalent of binary) written to these bits, the digital gain gets set to $N \times 0.2$ dB. |
| 10 | 0 | R/W | 0h | Must write 0 |
| 9-0 | OFFSET_ADC11e | R/W | 0h | When the DIG_OFFSET_EN bit (register 3, bit 8) is set to 1, the offset value to be subtracted from the even sample of ADC11 can be obtained with this 10-bit register. The offset value is in twos complement format and its LSB corresponds to a 14-bit LSB. |

12.1.1.39 Register 2Bh (address = 2Bh)

图 135. Register 2Bh

| | | | | | | | |
|---------------|----|----|----|----|--------|---------------|---|
| 15 | 14 | 13 | 12 | 11 | 10 | 9 | 8 |
| GAIN_ADC12o | | | | | 0 | OFFSET_ADC12o | |
| R/W-0h | | | | | R/W-0h | R/W-0h | |
| 7 | 6 | 5 | 4 | 3 | 2 | 1 | 0 |
| OFFSET_ADC12o | | | | | | | |
| R/W-0h | | | | | | | |

LEGEND: R/W = Read/Write; -n = value after reset

表 88. Register 2Bh Field Descriptions

| Bit | Field | Type | Reset | Description |
|-------|---------------|------|-------|--|
| 15-11 | GAIN_ADC12o | R/W | 0h | When the DIG_GAIN_EN bit (register 3, bit 12) is set to 1, the digital gain value for the odd sample of ADC12 can be obtained with this register. For a value of N (decimal equivalent of binary) written to these bits, the digital gain gets set to $N \times 0.2$ dB. |
| 10 | 0 | R/W | 0h | Must write 0 |
| 9-0 | OFFSET_ADC12o | R/W | 0h | When the DIG_OFFSET_EN bit (register 3, bit 8) is set to 1, the offset value to be subtracted from the odd sample of ADC12 can be obtained with this 10-bit register. The offset value is in twos complement format and its LSB corresponds to a 14-bit LSB. |

12.1.1.40 Register 2Ch (address = 2Ch)

图 136. Register 2Ch

| | | | | | | | |
|---------------|----|----|----|----|--------|---------------|---|
| 15 | 14 | 13 | 12 | 11 | 10 | 9 | 8 |
| GAIN_ADC12e | | | | | 0 | OFFSET_ADC12e | |
| R/W-0h | | | | | R/W-0h | R/W-0h | |
| 7 | 6 | 5 | 4 | 3 | 2 | 1 | 0 |
| OFFSET_ADC12e | | | | | | | |
| R/W-0h | | | | | | | |

LEGEND: R/W = Read/Write; -n = value after reset

表 89. Register 2Ch Field Descriptions

| Bit | Field | Type | Reset | Description |
|-------|---------------|------|-------|---|
| 15-11 | GAIN_ADC12e | R/W | 0h | When the DIG_GAIN_EN bit (register 3, bit 12) is set to 1, the digital gain value for the even sample of ADC12 can be obtained with this register. For a value of N (decimal equivalent of binary) written to these bits, the digital gain gets set to $N \times 0.2$ dB. |
| 10 | 0 | R/W | 0h | Must write 0 |
| 9-0 | OFFSET_ADC12e | R/W | 0h | When the DIG_OFFSET_EN bit (register 3, bit 8) is set to 1, the offset value to be subtracted from the even sample of ADC12 can be obtained with this 10-bit register. The offset value is in twos complement format and its LSB corresponds to a 14-bit LSB. |

12.1.1.41 Register 2Dh (address = 2Dh)
图 137. Register 2Dh

| | | | | | | | | | | | | | | | |
|----------------|--|-----------------|--|---------------------|--|--------------------|--|-----------|--|----|--|--------------------|--|---|--|
| 15 | | 14 | | 13 | | 12 | | 11 | | 10 | | 9 | | 8 | |
| PAT_PRBS_LVDS9 | | PAT_PRBS_LVDS10 | | PAT_PRBS_LVDS11 | | PAT_PRBS_LVDS12 | | PAT_LVDS9 | | | | PAT_LVDS10 | | | |
| R/W-0h | | R/W-0h | | R/W-0h | | R/W-0h | | R/W-0h | | | | R/W-0h | | | |
| 7 | | 6 | | 5 | | 4 | | 3 | | 2 | | 1 | | 0 | |
| PAT_LVDS10 | | | | HPF_ROUND_EN_CH9-16 | | HPF_CORNER_ADC9-12 | | | | | | DIG_HPF_EN_ADC9-12 | | | |
| R/W-0h | | | | R/W-0h | | R/W-0h | | | | | | R/W-0h | | | |

LEGEND: R/W = Read/Write; -n = value after reset

表 90. Register 2Dh Field Descriptions

| Bit | Field | Type | Reset | Description |
|------|---------------------|------|-------|--|
| 15 | PAT_PRBS_LVDS9 | R/W | 0h | When the PAT_SELECT_IND bit (register 4, bit 8) is set to 1, the PRBS pattern on LVDS output 9 can be enabled with this bit; see the LVDS Test Pattern Mode section for further details. |
| 14 | PAT_PRBS_LVDS10 | R/W | 0h | When the PAT_SELECT_IND bit (register 4, bit 8) is set to 1, the PRBS pattern on LVDS output 10 can be enabled with this bit; see the LVDS Test Pattern Mode section for further details. |
| 13 | PAT_PRBS_LVDS11 | R/W | 0h | When the PAT_SELECT_IND bit (register 4, bit 8) is set to 1, the PRBS pattern on LVDS output 11 can be enabled with this bit; see the LVDS Test Pattern Mode section for further details. |
| 12 | PAT_PRBS_LVDS12 | R/W | 0h | When the PAT_SELECT_IND bit (register 4, bit 8) is set to 1, the PRBS pattern on LVDS output 12 can be enabled with this bit; see the LVDS Test Pattern Mode section for further details. |
| 11-9 | PAT_LVDS9 | R/W | 0h | When the PAT_SELECT_IND bit (register 4, bit 8) is set to 1, the pattern on LVDS output 9 can be programmed with these bits; see 表 33 for bit descriptions. |
| 8-6 | PAT_LVDS10 | R/W | 0h | When the PAT_SELECT_IND bit (register 4, bit 8) is set to 1, the pattern on LVDS output 10 can be programmed with these bits; see 表 33 for bit descriptions. |
| 5 | HPF_ROUND_EN_CH9-16 | R/W | 0h | 0 = Rounding in the ADC HPF is disabled for channels 9-16. The HPF output is truncated to be mapped to the ADC resolution bits. 1 = HPF output of channels 9-16 is mapped to the ADC resolution bits by the round-off operation. |
| 4-1 | HPF_CORNER_ADC9-12 | R/W | 0h | When the DIG_HPF_EN_CH9-12 bit is set to 1, the digital HPF characteristic for the corresponding ADCs can be programmed by setting the value of k with these bits. The value of k can be from 2 to 10 (0010b to 1010b); see the Digital HPF section for further details. |
| 0 | DIG_HPF_EN_ADC9-12 | R/W | 0h | 0 = Digital HPF disabled for ADCs 9 to 12 (default) 1 = Enables digital HPF for ADCs 9 to 12 |

12.1.1.42 Register 2Fh (address = 2Fh)
图 138. Register 2Fh

| | | | | | | | |
|------------|--------|--------|------------|------------------|-------------------|-------------------|-------------------|
| 15 | 14 | 13 | 12 | 11 | 10 | 9 | 8 |
| 0 | 0 | 0 | 0 | IN_16CH_ ADC9 | IN_16CH_ ADC10 | IN_16CH_ ADC11 | IN_16CH_ ADC12 |
| R/W-0h | R/W-0h | R/W-0h | R/W-0h | R/W-0h | R/W-0h | R/W-0h | R/W-0h |
| 7 | 6 | 5 | 4 | 3 | 2 | 1 | 0 |
| PAT_LVDS11 | | | PAT_LVDS12 | | | 0 | 0 |
| R/W-0h | | | R/W-0h | | | R/W-0h | R/W-0h |

LEGEND: R/W = Read/Write; -n = value after reset

表 91. Register 2Fh Field Descriptions

| Bit | Field | Type | Reset | Description |
|-------|-----------------|------|-------|--|
| 15-12 | 0 | R/W | 0h | Must write 0 |
| 11 | IN_16CH_ADC9 | R/W | 0h | Selects the input pair sampled by ADC9 in 16-input mode. 0 = ADC9 samples the signal on INP17, INM17 1 = ADC9 samples the signal on INP18, INM18 |
| 10 | IN_16CH_ADC10 | R/W | 0h | Selects the input pair sampled by ADC10 in 16-input mode. 0 = ADC10 samples the signal on INP19, INM19 1 = ADC10 samples the signal on INP20, INM20 |
| 9 | IN_16CH_ADC11 | R/W | 0h | Selects the input pair sampled by ADC11 in 16-input mode. 0 = ADC11 samples the signal on INP21, INM21 1 = ADC11 samples the signal on INP22, INM22 |
| 8 | IN_16CH_ADC12 | R/W | 0h | Selects the input pair sampled by ADC12 in 16-input mode. 0 = ADC12 samples the signal on INP23, INM23 1 = ADC12 samples the signal on INP24, INM24 |
| 7-5 | PAT_LVDS11[2:0] | R/W | 0h | When the PAT_SELECT_IND bit (register 4, bit 8) is set to 1, the pattern on LVDS output 11 can be programmed with these bits; see 表 33 for bit descriptions. |
| 4-2 | PAT_LVDS12[2:0] | R/W | 0h | When the PAT_SELECT_IND bit (register 4, bit 8) is set to 1, the pattern on LVDS output 12 can be programmed with these bits; see 表 33 for bit descriptions. |
| 1-0 | 0 | R/W | 0h | Must write 0 |

12.1.1.43 Register 30h (address = 30h)
图 139. Register 30h

| 15 | 14 | 13 | 12 | 11 | 10 | 9 | 8 |
|---------------|---------------|---------------|--------------|---------------|---------------|---------------|--------------|
| PDN_DIG_ADC12 | PDN_DIG_ADC11 | PDN_DIG_ADC10 | PDN_DIG_ADC9 | PDN_LVDS12 | PDN_LVDS11 | PDN_LVDS10 | PDN_LVDS9 |
| R/W-0h | R/W-0h | R/W-0h | R/W-0h | R/W-0h | R/W-0h | R/W-0h | R/W-0h |
| 7 | 6 | 5 | 4 | 3 | 2 | 1 | 0 |
| PDN_ANA_ADC12 | PDN_ANA_ADC11 | PDN_ANA_ADC10 | PDN_ANA_ADC9 | INVERT_LVDS12 | INVERT_LVDS11 | INVERT_LVDS10 | INVERT_LVDS9 |
| R/W-0h | R/W-0h | R/W-0h | R/W-0h | R/W-0h | R/W-0h | R/W-0h | R/W-0h |

LEGEND: R/W = Read/Write; W = Write only; = value after reset

表 92. Register 30h Field Descriptions

| Bit | Field | Type | Reset | Description |
|-----|---------------|------|-------|---|
| 15 | PDN_DIG_ADC12 | R/W | 0h | 0 = Normal operation (default) 1 = Powers down the digital block for ADC12 |
| 14 | PDN_DIG_ADC11 | R/W | 0h | 0 = Normal operation (default) 1 = Powers down the digital block for ADC11 |
| 13 | PDN_DIG_ADC10 | R/W | 0h | 0 = Normal operation (default) 1 = Powers down the digital block for ADC10 |
| 12 | PDN_DIG_ADC9 | R/W | 0h | 0 = Normal operation (default) 1 = Powers down the digital block for ADC9 |
| 11 | PDN_LVDS12 | R/W | 0h | 0 = Normal operation (default) 1 = Powers down LVDS output line 12 |
| 10 | PDN_LVDS11 | R/W | 0h | 0 = Normal operation (default) 1 = Powers down LVDS output line 11 |
| 9 | PDN_LVDS10 | R/W | 0h | 0 = Normal operation (default) 1 = Powers down LVDS output line 10 |
| 8 | PDN_LVDS9 | R/W | 0h | 0 = Normal operation (default) 1 = Powers down LVDS output line 9 |
| 7 | PDN_ANA_ADC12 | R/W | 0h | 0 = Normal operation (default) 1 = Powers down the analog block for ADC12 |
| 6 | PDN_ANA_ADC11 | R/W | 0h | 0 = Normal operation (default) 1 = Powers down the analog block for ADC11 |
| 5 | PDN_ANA_ADC10 | R/W | 0h | 0 = Normal operation (default) 1 = Powers down the analog block for ADC10 |
| 4 | PDN_ANA_ADC9 | R/W | 0h | 0 = Normal operation (default) 1 = Powers down the analog block for ADC9 |
| 3 | INVERT_LVDS12 | R/W | 0h | 0 = Normal operation (default) 1 = Inverts ADC data sent on LVDS output line 12. Has no effect on Test patterns. |
| 2 | INVERT_LVDS11 | R/W | 0h | 0 = Normal operation (default) 1 = Inverts ADC data sent on LVDS output line 11. Has no effect on Test patterns. |
| 1 | INVERT_LVDS10 | R/W | 0h | 0 = Normal operation (default) 1 = Inverts ADC data sent on LVDS output line 10. Has no effect on Test patterns. |
| 0 | INVERT_LVDS9 | R/W | 0h | 0 = Normal operation (default) 1 = Inverts ADC data sent on LVDS output line 9. Has no effect on Test patterns. |

12.1.1.44 Register 31h (address = 31h)
图 140. Register 31h

| | | | | | | | |
|---------------|----|----|----|----|--------|---------------|---|
| 15 | 14 | 13 | 12 | 11 | 10 | 9 | 8 |
| GAIN_ADC13o | | | | | 0 | OFFSET_ADC13o | |
| R/W-0h | | | | | R/W-0h | R/W-0h | |
| 7 | 6 | 5 | 4 | 3 | 2 | 1 | 0 |
| OFFSET_ADC13o | | | | | | | |
| R/W-0h | | | | | | | |

LEGEND: R/W = Read/Write; -n = value after reset

表 93. Register 31h Field Descriptions

| Bit | Field | Type | Reset | Description |
|-------|---------------|------|-------|--|
| 15-11 | GAIN_ADC13o | R/W | 0h | When the DIG_GAIN_EN bit (register 3, bit 12) is set to 1, the digital gain value for the odd sample of ADC13 can be obtained with this register. For a value of N (decimal equivalent of binary) written to these bits, the digital gain gets set to $N \times 0.2$ dB. |
| 10 | 0 | R/W | 0h | Must write 0 |
| 9-0 | OFFSET_ADC13o | R/W | 0h | When the DIG_OFFSET_EN bit (register 3, bit 8) is set to 1, the offset value to be subtracted from the odd sample of ADC13 can be obtained with this 10-bit register. The offset value is in twos complement format and its LSB corresponds to a 14-bit LSB. |

12.1.1.45 Register 32h (address = 32h)
图 141. Register 32h

| | | | | | | | |
|---------------|----|----|----|----|--------|---------------|---|
| 15 | 14 | 13 | 12 | 11 | 10 | 9 | 8 |
| GAIN_ADC13e | | | | | 0 | OFFSET_ADC13e | |
| R/W-0h | | | | | R/W-0h | R/W-0h | |
| 7 | 6 | 5 | 4 | 3 | 2 | 1 | 0 |
| OFFSET_ADC13e | | | | | | | |
| R/W-0h | | | | | | | |

LEGEND: R/W = Read/Write; -n = value after reset

表 94. Register 32h Field Descriptions

| Bit | Field | Type | Reset | Description |
|-------|---------------|------|-------|---|
| 15-11 | GAIN_ADC13e | R/W | 0h | When the DIG_GAIN_EN bit (register 3, bit 12) is set to 1, the digital gain value for the even sample of ADC13 can be obtained with this register. For a value of N (decimal equivalent of binary) written to these bits, the digital gain gets set to $N \times 0.2$ dB. |
| 10 | 0 | R/W | 0h | Must write 0 |
| 9-0 | OFFSET_ADC13e | R/W | 0h | When the DIG_OFFSET_EN bit (register 3, bit 8) is set to 1, the offset value to be subtracted from the even sample of ADC13 can be obtained with this 10-bit register. The offset value is in twos complement format and its LSB corresponds to a 14-bit LSB. |

12.1.1.46 Register 33h (address = 33h)
图 142. Register 33h

| | | | | | | | |
|---------------|----|----|----|----|--------|---------------|---|
| 15 | 14 | 13 | 12 | 11 | 10 | 9 | 8 |
| GAIN_ADC14o | | | | | 0 | OFFSET_ADC14o | |
| R/W-0h | | | | | R/W-0h | R/W-0h | |
| 7 | 6 | 5 | 4 | 3 | 2 | 1 | 0 |
| OFFSET_ADC14o | | | | | | | |
| R/W-0h | | | | | | | |

LEGEND: R/W = Read/Write; -n = value after reset

表 95. Register 33h Field Descriptions

| Bit | Field | Type | Reset | Description |
|-------|---------------|------|-------|--|
| 15-11 | GAIN_ADC14o | R/W | 0h | When the DIG_GAIN_EN bit (register 3, bit 12) is set to 1, the digital gain value for the odd sample of ADC14 can be obtained with this register. For a value of N (decimal equivalent of binary) written to these bits, the digital gain gets set to $N \times 0.2$ dB. |
| 10 | 0 | R/W | 0h | Must write 0 |
| 9-0 | OFFSET_ADC14o | R/W | 0h | When the DIG_OFFSET_EN bit (register 3, bit 8) is set to 1, the offset value to be subtracted from the odd sample of ADC14 can be obtained with this 10-bit register. The offset value is in twos complement format and its LSB corresponds to a 14-bit LSB. |

12.1.1.47 Register 34h (address = 34h)
图 143. Register 34h

| | | | | | | | |
|---------------|----|----|----|----|--------|---------------|---|
| 15 | 14 | 13 | 12 | 11 | 10 | 9 | 8 |
| GAIN_ADC14e | | | | | 0 | OFFSET_ADC14e | |
| R/W-0h | | | | | R/W-0h | R/W-0h | |
| 7 | 6 | 5 | 4 | 3 | 2 | 1 | 0 |
| OFFSET_ADC14e | | | | | | | |
| R/W-0h | | | | | | | |

LEGEND: R/W = Read/Write; -n = value after reset

表 96. Register 34h Field Descriptions

| Bit | Field | Type | Reset | Description |
|-------|---------------|------|-------|---|
| 15-11 | GAIN_ADC14e | R/W | 0h | When the DIG_GAIN_EN bit (register 3, bit 12) is set to 1, the digital gain value for the even sample of ADC14 can be obtained with this register. For a value of N (decimal equivalent of binary) written to these bits, the digital gain gets set to $N \times 0.2$ dB. |
| 10 | 0 | R/W | 0h | Must write 0 |
| 9-0 | OFFSET_ADC14e | R/W | 0h | When the DIG_OFFSET_EN bit (register 3, bit 8) is set to 1, the offset value to be subtracted from the even sample of ADC14 can be obtained with this 10-bit register. The offset value is in twos complement format and its LSB corresponds to a 14-bit LSB. |

12.1.1.48 Register 35h (address = 35h)

图 144. Register 35h

| | | | | | | | |
|---------------|----|----|----|----|--------|---------------|---|
| 15 | 14 | 13 | 12 | 11 | 10 | 9 | 8 |
| GAIN_ADC15o | | | | | 0 | OFFSET_ADC15o | |
| R/W-0h | | | | | R/W-0h | R/W-0h | |
| 7 | 6 | 5 | 4 | 3 | 2 | 1 | 0 |
| OFFSET_ADC15o | | | | | | | |
| R/W-0h | | | | | | | |

LEGEND: R/W = Read/Write; -n = value after reset

表 97. Register 35h Field Descriptions

| Bit | Field | Type | Reset | Description |
|-------|---------------|------|-------|--|
| 15-11 | GAIN_ADC15o | R/W | 0h | When the DIG_GAIN_EN bit (register 3, bit 12) is set to 1, the digital gain value for the odd sample of ADC15 can be obtained with this register. For a value of N (decimal equivalent of binary) written to these bits, the digital gain gets set to $N \times 0.2$ dB. |
| 10 | 0 | R/W | 0h | Must write 0 |
| 9-0 | OFFSET_ADC15o | R/W | 0h | When the DIG_OFFSET_EN bit (register 3, bit 8) is set to 1, the offset value to be subtracted from the odd sample of ADC15 can be obtained with this 10-bit register. The offset value is in twos complement format and its LSB corresponds to a 14-bit LSB. |

12.1.1.49 Register 36h (address = 36h)

图 145. Register 36h

| | | | | | | | |
|---------------|----|----|----|----|--------|---------------|---|
| 15 | 14 | 13 | 12 | 11 | 10 | 9 | 8 |
| GAIN_ADC15e | | | | | 0 | OFFSET_ADC15e | |
| R/W-0h | | | | | R/W-0h | R/W-0h | |
| 7 | 6 | 5 | 4 | 3 | 2 | 1 | 0 |
| OFFSET_ADC15e | | | | | | | |
| R/W-0h | | | | | | | |

LEGEND: R/W = Read/Write; -n = value after reset

表 98. Register 36h Field Descriptions

| Bit | Field | Type | Reset | Description |
|-------|---------------|------|-------|---|
| 15-11 | GAIN_ADC15e | R/W | 0h | When the DIG_GAIN_EN bit (register 3, bit 12) is set to 1, the digital gain value for the even sample of ADC15 can be obtained with this register. For a value of N (decimal equivalent of binary) written to these bits, the digital gain gets set to $N \times 0.2$ dB. |
| 10 | 0 | R/W | 0h | Must write 0 |
| 9-0 | OFFSET_ADC15e | R/W | 0h | When the DIG_OFFSET_EN bit (register 3, bit 8) is set to 1, the offset value to be subtracted from the even sample of ADC15 can be obtained with this 10-bit register. The offset value is in twos complement format and its LSB corresponds to a 14-bit LSB. |

12.1.1.50 Register 37h (address = 37h)
图 146. Register 37h

| | | | | | | | |
|---------------|----|----|----|----|--------|---------------|---|
| 15 | 14 | 13 | 12 | 11 | 10 | 9 | 8 |
| GAIN_ADC16o | | | | | 0 | OFFSET_ADC16o | |
| R/W-0h | | | | | R/W-0h | R/W-0h | |
| 7 | 6 | 5 | 4 | 3 | 2 | 1 | 0 |
| OFFSET_ADC16o | | | | | | | |
| R/W-0h | | | | | | | |

LEGEND: R/W = Read/Write; -n = value after reset

表 99. Register 37h Field Descriptions

| Bit | Field | Type | Reset | Description |
|-------|---------------|------|-------|--|
| 15-11 | GAIN_ADC16o | R/W | 0h | When the DIG_GAIN_EN bit (register 3, bit 12) is set to 1, the digital gain value for the odd sample of ADC16 can be obtained with this register. For a value of N (decimal equivalent of binary) written to these bits, the digital gain gets set to $N \times 0.2$ dB. |
| 10 | 0 | R/W | 0h | Must write 0 |
| 9-0 | OFFSET_ADC16o | R/W | 0h | When the DIG_OFFSET_EN bit (register 3, bit 8) is set to 1, the offset value to be subtracted from the odd sample of ADC16 can be obtained with this 10-bit register. The offset value is in twos complement format and its LSB corresponds to a 14-bit LSB. |

12.1.1.51 Register 38h (address = 38h)
图 147. Register 38h

| | | | | | | | |
|---------------|----|----|----|----|--------|---------------|---|
| 15 | 14 | 13 | 12 | 11 | 10 | 9 | 8 |
| GAIN_ADC16e | | | | | 0 | OFFSET_ADC16e | |
| R/W-0h | | | | | R/W-0h | R/W-0h | |
| 7 | 6 | 5 | 4 | 3 | 2 | 1 | 0 |
| OFFSET_ADC16e | | | | | | | |
| R/W-0h | | | | | | | |

LEGEND: R/W = Read/Write; -n = value after reset

表 100. Register 38h Field Descriptions

| Bit | Field | Type | Reset | Description |
|-------|---------------|------|-------|---|
| 15-11 | GAIN_ADC16e | R/W | 0h | When the DIG_GAIN_EN bit (register 3, bit 12) is set to 1, the digital gain value for the even sample of ADC16 can be obtained with this register. For a value of N (decimal equivalent of binary) written to these bits, the digital gain gets set to $N \times 0.2$ dB. |
| 10 | 0 | R/W | 0h | Must write 0 |
| 9-0 | OFFSET_ADC16e | R/W | 0h | When the DIG_OFFSET_EN bit (register 3, bit 8) is set to 1, the offset value to be subtracted from the even sample of ADC16 can be obtained with this 10-bit register. The offset value is in twos complement format and its LSB corresponds to a 14-bit LSB. |

12.1.1.52 Register 39h (address = 39h)
图 148. Register 39h

| | | | | | | | | | | | | | | | |
|-----------------|--|-----------------|--|-----------------|--|---------------------|--|------------|--|----|--|---------------------|--|---|--|
| 15 | | 14 | | 13 | | 12 | | 11 | | 10 | | 9 | | 8 | |
| PAT_PRBS_LVDS13 | | PAT_PRBS_LVDS14 | | PAT_PRBS_LVDS15 | | PAT_PRBS_LVDS16 | | PAT_LVDS13 | | | | PAT_LVDS14 | | | |
| R/W-0h | | R/W-0h | | R/W-0h | | R/W-0h | | R/W-0h | | | | R/W-0h | | | |
| 7 | | 6 | | 5 | | 4 | | 3 | | 2 | | 1 | | 0 | |
| PAT_LVDS14 | | | | 0 | | HPF_CORNER_ADC13-16 | | | | | | DIG_HPF_EN_ADC13-16 | | | |
| R/W-0h | | | | R/W-0h | | R/W-0h | | | | | | R/W-0h | | | |

LEGEND: R/W = Read/Write; -n = value after reset

表 101. Register 39h Field Descriptions

| Bit | Field | Type | Reset | Description |
|------|---------------------|------|-------|---|
| 15 | PAT_PRBS_LVDS13 | R/W | 0h | When the PAT_SELECT_IND bit (register 4, bit 8) is set to 1, the PRBS pattern on LVDS output 13 can be enabled with this bit; see the LVDS Test Pattern Mode section for further details. |
| 14 | PAT_PRBS_LVDS14 | R/W | 0h | When the PAT_SELECT_IND bit (register 4, bit 8) is set to 1, the PRBS pattern on LVDS output 14 can be enabled with this bit; see the LVDS Test Pattern Mode section for further details. |
| 13 | PAT_PRBS_LVDS15 | R/W | 0h | When the PAT_SELECT_IND bit (register 4, bit 8) is set to 1, the PRBS pattern on LVDS output 15 can be enabled with this bit; see the LVDS Test Pattern Mode section for further details. |
| 12 | PAT_PRBS_LVDS16 | R/W | 0h | When the PAT_SELECT_IND bit (register 4, bit 8) is set to 1, the PRBS pattern on LVDS output 16 can be enabled with this bit; see the LVDS Test Pattern Mode section for further details. |
| 11-9 | PAT_LVDS13[2:0] | R/W | 0h | When the PAT_SELECT_IND bit (register 4, bit 8) is set to 1, the pattern on LVDS output 13 can be programmed with these bits; see 表 33 for bit descriptions. |
| 8-6 | PAT_LVDS14[2:0] | R/W | 0h | When the PAT_SELECT_IND bit (register 4, bit 8) is set to 1, the pattern on LVDS output 14 can be programmed with these bits; see 表 33 for bit descriptions. |
| 5 | 0 | R/W | 0h | Must write 0 |
| 4-1 | HPF_CORNER_ADC13-16 | R/W | 0h | When the DIG_HPF_EN_CH13-16 bit is set to 1, the digital HPF characteristic for the corresponding ADCs can be programmed by setting the value of k with these bits. The value of k can be from 2 to 10 (0010b to 1010b); see the Digital HPF section for further details. |
| 0 | DIG_HPF_EN_ADC13-16 | R/W | 0h | 0 = Digital HPF disabled for ADCs 13 to 16 (default) 1 = Enables digital HPF for ADCs 13 to 16 |

12.1.1.53 Register 3Bh (address = 3Bh)
图 149. Register 3Bh

| | | | | | | | |
|------------|--------|--------|------------|-------------------|-------------------|-------------------|-------------------|
| 15 | 14 | 13 | 12 | 11 | 10 | 9 | 8 |
| 0 | 0 | 0 | 0 | IN_16CH_ ADC13 | IN_16CH_ ADC14 | IN_16CH_ ADC15 | IN_16CH_ ADC16 |
| R/W-0h | R/W-0h | R/W-0h | R/W-0h | R/W-0h | R/W-0h | R/W-0h | R/W-0h |
| 7 | 6 | 5 | 4 | 3 | 2 | 1 | 0 |
| PAT_LVDS15 | | | PAT_LVDS16 | | | 0 | 0 |
| R/W-0h | | | R/W-0h | | | R/W-0h | R/W-0h |

LEGEND: R/W = Read/Write; -n = value after reset

表 102. Register 3Bh Field Descriptions

| Bit | Field | Type | Reset | Description |
|-------|-----------------|------|-------|--|
| 15-12 | 0 | R/W | 0h | Must write 0 |
| 11 | IN_16CH_ADC13 | R/W | 0h | Selects the input pair sampled by ADC13 in 16-input mode. 0 = ADC13 samples the signal on INP25, INM25 1 = ADC13 samples the signal on INP26, INM26 |
| 10 | IN_16CH_ADC14 | R/W | 0h | Selects the input pair sampled by ADC14 in 16-input mode. 0 = ADC14 samples the signal on INP27, INM27 1 = ADC14 samples the signal on INP28, INM28 |
| 9 | IN_16CH_ADC15 | R/W | 0h | Selects the input pair sampled by ADC15 in 16-input mode. 0 = ADC15 samples the signal on INP29, INM29 1 = ADC15 samples the signal on INP30, INM30 |
| 8 | IN_16CH_ADC16 | R/W | 0h | Selects the input pair sampled by ADC16 in 16-input mode. 0 = ADC16 samples the signal on INP31, INM31 1 = ADC16 samples the signal on INP32, INM32 |
| 7-5 | PAT_LVDS15[2:0] | R/W | 0h | When the PAT_SELECT_IND bit (register 4, bit 8) is set to 1, the pattern on LVDS output 15 can be programmed with these bits; see 表 33 for bit descriptions. |
| 4-2 | PAT_LVDS16[2:0] | R/W | 0h | When the PAT_SELECT_IND bit (register 4, bit 8) is set to 1, the pattern on LVDS output 16 can be programmed with these bits; see 表 33 for bit descriptions. |
| 1-0 | 0 | R/W | 0h | Must write 0 |

12.1.1.54 Register 3Ch (address = 3Ch)
图 150. Register 3Ch

| | | | | | | | | | | | | | | | |
|----------|----------|----------|----------|----------|----------|----------|----------|------------|------------|------------|------------|------------|------------|------------|-----------|
| 15 | | 14 | | 13 | | 12 | | 11 | | 10 | | 9 | | 8 | |
| PDN_DIG_ | PDN_DIG_ | PDN_DIG_ | PDN_DIG_ | PDN_DIG_ | PDN_DIG_ | PDN_DIG_ | PDN_DIG_ | PDN_LVDS16 | PDN_LVDS15 | PDN_LVDS14 | PDN_LVDS13 | PDN_LVDS12 | PDN_LVDS11 | PDN_LVDS10 | PDN_LVDS9 |
| ADC16 | ADC15 | ADC14 | ADC13 | ADC12 | ADC11 | ADC10 | ADC9 | | | | | | | | |
| R/W-0h | R/W-0h | R/W-0h | R/W-0h | R/W-0h | R/W-0h | R/W-0h | R/W-0h | R/W-0h | R/W-0h | R/W-0h | R/W-0h | R/W-0h | R/W-0h | R/W-0h | R/W-0h |
| 7 | | 6 | | 5 | | 4 | | 3 | | 2 | | 1 | | 0 | |
| PDN_ANA_ | PDN_ANA_ | PDN_ANA_ | PDN_ANA_ | PDN_ANA_ | PDN_ANA_ | PDN_ANA_ | PDN_ANA_ | INVERT_ | INVERT_ | INVERT_ | INVERT_ | INVERT_ | INVERT_ | INVERT_ | INVERT_ |
| ADC16 | ADC15 | ADC14 | ADC13 | ADC12 | ADC11 | ADC10 | ADC9 | LVDS16 | LVDS15 | LVDS14 | LVDS13 | LVDS12 | LVDS11 | LVDS10 | LVDS9 |
| R/W-0h | R/W-0h | R/W-0h | R/W-0h | R/W-0h | R/W-0h | R/W-0h | R/W-0h | R/W-0h | R/W-0h | R/W-0h | R/W-0h | R/W-0h | R/W-0h | R/W-0h | R/W-0h |

LEGEND: R/W = Read/Write; -n = value after reset

表 103. Register 3Ch Field Descriptions

| Bit | Field | Type | Reset | Description |
|-----|---------------|------|-------|---|
| 15 | PDN_DIG_ADC16 | R/W | 0h | 0 = Normal operation (default) 1 = Powers down the digital block for ADC16 |
| 14 | PDN_DIG_ADC15 | R/W | 0h | 0 = Normal operation (default) 1 = Powers down the digital block for ADC15 |
| 13 | PDN_DIG_ADC14 | R/W | 0h | 0 = Normal operation (default) 1 = Powers down the digital block for ADC14 |
| 12 | PDN_DIG_ADC13 | R/W | 0h | 0 = Normal operation (default) 1 = Powers down the digital block for ADC13 |
| 11 | PDN_LVDS16 | R/W | 0h | 0 = Normal operation (default) 1 = Powers down LVDS output line 16 |
| 10 | PDN_LVDS15 | R/W | 0h | 0 = Normal operation (default) 1 = Powers down LVDS output line 15 |
| 9 | PDN_LVDS14 | R/W | 0h | 0 = Normal operation (default) 1 = Powers down LVDS output line 14 |
| 8 | PDN_LVDS13 | R/W | 0h | 0 = Normal operation (default) 1 = Powers down LVDS output line 13 |
| 7 | PDN_ANA_ADC16 | R/W | 0h | 0 = Normal operation (default) 1 = Powers down the analog block for ADC16 |
| 6 | PDN_ANA_ADC15 | R/W | 0h | 0 = Normal operation (default) 1 = Powers down the analog block for ADC15 |
| 5 | PDN_ANA_ADC14 | R/W | 0h | 0 = Normal operation (default) 1 = Powers down the analog block for ADC14 |
| 4 | PDN_ANA_ADC13 | R/W | 0h | 0 = Normal operation (default) 1 = Powers down the analog block for ADC13 |
| 3 | INVERT_LVDS16 | R/W | 0h | 0 = Normal operation (default) 1 = Inverts ADC data sent on LVDS output line 16. Has no effect on Test patterns. |
| 2 | INVERT_LVDS15 | R/W | 0h | 0 = Normal operation (default) 1 = Inverts ADC data sent on LVDS output line 15. Has no effect on Test patterns. |
| 1 | INVERT_LVDS14 | R/W | 0h | 0 = Normal operation (default) 1 = Inverts ADC data sent on LVDS output line 14. Has no effect on Test patterns. |
| 0 | INVERT_LVDS13 | R/W | 0h | 0 = Normal operation (default) 1 = Inverts ADC data sent on LVDS output line 13. Has no effect on Test patterns. |

12.1.1.55 Register 43h (address = 43h)
图 151. Register 43h

| | | | | | | | | | | | | | | | |
|--------|--|--------|--|--------|--|----------------------|--|--------|--|--------|--|--------|--|--------|--|
| 15 | | 14 | | 13 | | 12 | | 11 | | 10 | | 9 | | 8 | |
| 0 | | 0 | | 0 | | 0 | | 0 | | 0 | | 0 | | 0 | |
| R/W-0h | | R/W-0h | | R/W-0h | | R/W-0h | | R/W-0h | | R/W-0h | | R/W-0h | | R/W-0h | |
| 7 | | 6 | | 5 | | 4 | | 3 | | 2 | | 1 | | 0 | |
| 0 | | 0 | | 0 | | LVDS_DCLK_DELAY_PROG | | | | | | | | 0 | |
| R/W-0h | | R/W-0h | | R/W-0h | | R/W-0h | | | | | | | | R/W-0h | |

LEGEND: R/W = Read/Write; -n = value after reset

表 104. Register 43h Field Descriptions

| Bit | Field | Type | Reset | Description |
|------|----------------------|------|-------|--|
| 15-5 | 0 | R/W | 0h | Must write 0 |
| 4-1 | LVDS_DCLK_DELAY_PROG | R/W | 0h | The LVDS DCLK output delay is programmable with 110-ps steps. Delay values are in twos complement format. Increasing the positive delay increases setup time and reduces hold time, and vice-versa for the negative delay. 0000 = No delay 0001 = 110 ps 0010 = 220 ps ... 1110 = -220 ps 1111 = -110ps ... |
| 0 | 0 | R/W | 0h | Must write 0 |

12.2 JESD Serial Interface Registers

This section discusses the JESD registers. A register map is available in [表 105](#).

表 105. JESD Register Map

| REGISTER ADDRESS | | REGISTER DATA ⁽¹⁾ | | | | | | | | | | | | | | | | |
|--------------------|-----|------------------------------|-------------------------|-------------|-------------|--------------------|--------------------|--------------------|--------------------|------------------|---|------------------|-------------------------|---|--------------|--------------|---|--|
| DECIMAL | HEX | 15 | 14 | 13 | 12 | 11 | 10 | 9 | 8 | 7 | 6 | 5 | 4 | 3 | 2 | 1 | 0 | |
| 70 | 46 | 0 | 0 | 0 | 0 | 0 | 0 | 0 | 0 | 0 | 0 | 0 | 0 | 0 | MASK_TX_TRIG | JESD_RESET1 | 0 | |
| 73 | 49 | IDLE_MODE | 0 | 0 | LANE_ALIGN | FRAME_ALIGN | LINK_CONFIG_DIS | 0 | 0 | 0 | 0 | 0 | 0 | 0 | FORCE_K | 0 | 0 | |
| 74 | 4A | LINK_LAYER_TESTMODES | | | TX_SYNC_REQ | RELEASE_ILA | | 0 | JESD_RES_ET2 | JESD_RES_ET3 | 0 | 0 | 0 | 0 | 0 | 0 | 0 | |
| 75 | 4B | 0 | 0 | 0 | 0 | 0 | 0 | 0 | SING_CONV_PER_OCT | NUM_ADC_PER_LANE | | | 0 | 0 | 0 | 0 | 0 | |
| 77 | 4D | 0 | 0 | 0 | 0 | 0 | 0 | 0 | 0 | PRE_EMP | | | | 0 | 0 | 0 | 0 | |
| 80 | 50 | 0 | 0 | 0 | 0 | 0 | 0 | 0 | 0 | 0 | 0 | 0 | 0 | 0 | 0 | INC_JESD_VDD | 0 | |
| 81 | 51 | DEVICE_ID | | | | | | | | 0 | 0 | 0 | BANK_ID | | | | | |
| 82 | 52 | 0 | 0 | 0 | 0 | 0 | 0 | 0 | 0 | SCR_EN | 0 | 0 | 0 | 0 | 0 | 0 | 0 | |
| 83 | 53 | 0 | 0 | 0 | 0 | 0 | 0 | 0 | 0 | 0 | 0 | K_VALUE_TO_FORCE | | | | | | |
| 85 | 55 | JESD_SUBCLASS | | | 0 | 0 | 0 | 0 | 0 | JESD_VER | | | 0 | 0 | 0 | 0 | 0 | |
| 115 ⁽²⁾ | 73 | EN_LANE_ID1 | EN_LANE_ID2 | EN_LANE_ID3 | EN_LANE_ID4 | EN_CHECK_SUM_LANE1 | EN_CHECK_SUM_LANE2 | EN_CHECK_SUM_LANE3 | EN_CHECK_SUM_LANE4 | 0 | 0 | 0 | ENABLE_JESD_VER_CONTROL | 0 | 0 | 0 | 0 | |
| 116 ⁽²⁾ | 74 | CHECK_SUM1 | | | | | | | | CHECK_SUM2 | | | | | | | | |
| 117 ⁽²⁾ | 75 | CHECK_SUM3 | | | | | | | | CHECK_SUM4 | | | | | | | | |
| 118 ⁽²⁾ | 76 | 0 | 0 | 0 | LANE_ID1 | | | | | 0 | 0 | 0 | LANE_ID2 | | | | | |
| 119 ⁽²⁾ | 77 | 0 | 0 | 0 | LANE_ID3 | | | | | 0 | 0 | 0 | LANE_ID4 | | | | | |
| 120 | 78 | FORCE_LMFC_COUNT | LMFC_COUNTER_INIT_VALUE | | | | | | 0 | 0 | 0 | 0 | 0 | 0 | 0 | 0 | 0 | |
| 134 ⁽²⁾ | 86 | EN_LANE_ID5 | EN_LANE_ID6 | EN_LANE_ID7 | EN_LANE_ID8 | EN_CHECK_SUM_LANE5 | EN_CHECK_SUM_LANE6 | EN_CHECK_SUM_LANE7 | EN_CHECK_SUM_LANE8 | 0 | 0 | 0 | 0 | 0 | 0 | 0 | 0 | |
| 135 ⁽²⁾ | 87 | CHECK_SUM5 | | | | | | | | CHECK_SUM6 | | | | | | | | |
| 136 ⁽²⁾ | 88 | CHECK_SUM7 | | | | | | | | CHECK_SUM8 | | | | | | | | |
| 137 ⁽²⁾ | 89 | 0 | 0 | 0 | LANE_ID5 | | | | | 0 | 0 | 0 | LANE_ID6 | | | | | |
| 138 ⁽²⁾ | 8A | 0 | 0 | 0 | LANE_ID7 | | | | | 0 | 0 | 0 | LANE_ID8 | | | | | |

(1) Default value of all registers is 0.

(2) These registers must only be written to after setting the JESD_WR_SEL register bit (register 3, bit 5) to 1. To write any other registers, set the JESD_WR_SEL bit to 0.

12.2.1 Description of JESD Serial Interface Registers

12.2.1.1 Register 70 (address = 46h)

图 152. Register 70

| | | | | | | | |
|--------|--------|--------|--------|--------|--------------|-------------|--------|
| 15 | 14 | 13 | 12 | 11 | 10 | 9 | 8 |
| 0 | 0 | 0 | 0 | 0 | 0 | 0 | 0 |
| R/W-0h | R/W-0h | R/W-0h | R/W-0h | R/W-0h | R/W-0h | R/W-0h | R/W-0h |
| 7 | 6 | 5 | 4 | 3 | 2 | 1 | 0 |
| 0 | 0 | 0 | 0 | 0 | MASK_TX_TRIG | JESD_RESET1 | 0 |
| R/W-0h | R/W-0h | R/W-0h | R/W-0h | R/W-0h | R/W-0h | R/W-0h | R/W-0h |

LEGEND: R/W = Read/Write; -n = value after reset

表 106. Register 70 Field Descriptions

| Bit | Field | Type | Reset | Description |
|------|--------------|------|-------|---|
| 15-3 | 0 | R/W | 0h | Must write 0 |
| 2 | MASK_TX_TRIG | R/W | 0h | 0 = TX_TRIG affects internal clock-phase resets 1 = TX_TRIG does not affect internal clock-phase resets |
| 1 | JESD_RESET1 | R/W | 0h | 0 = SYNC~ and SYSREF events reset non-JESD blocks (such as the clock dividers, demodulator, and test pattern generator) 1 = SYNC~ and SYSREF events do not reset non-JESD blocks (such as the clock dividers, demodulator, and test pattern generator) |
| 0 | 0 | R/W | 0h | Must write 0 |

12.2.1.2 Register 73 (address = 49h)

图 153. Register 73

| | | | | | | | |
|-----------|--------|--------|------------|-------------|-----------------|--------|--------|
| 15 | 14 | 13 | 12 | 11 | 10 | 9 | 8 |
| IDLE_MODE | 0 | 0 | LANE_ALIGN | FRAME_ALIGN | LINK_CONFIG_DIS | 0 | 0 |
| R/W-0h | R/W-0h | R/W-0h | R/W-0h | R/W-0h | R/W-0h | R/W-0h | R/W-0h |
| 7 | 6 | 5 | 4 | 3 | 2 | 1 | 0 |
| 0 | 0 | 0 | 0 | 0 | FORCE_K | 0 | 0 |
| R/W-0h | R/W-0h | R/W-0h | R/W-0h | R/W-0h | R/W-0h | R/W-0h | R/W-0h |

LEGEND: R/W = Read/Write; -n = value after reset

表 107. Register 73 Field Descriptions

| Bit | Field | Type | Reset | Description |
|-------|-----------------|------|-------|--|
| 15 | IDLE_MODE | R/W | 0h | 0 = Idle mode disabled (normal operation) 1 = Device sends a continuous pattern (BC50h) on all lanes |
| 14-13 | 0 | R/W | 0h | Must write 0 |
| 12 | LANE_ALIGN | R/W | 0h | 0 = Character replacement disabled. Data are sent without inserting a lane alignment control character. 1 = If the last octet of the multiframe is the same as the last octet of the previous multiframe, then the last octet is replaced with a /K28.3/ character that can be used by the receiver for lane alignment monitoring and correction; see the JESD204B document., section 5.3.3.4 for details. |
| 11 | FRAME_ALIGN | R/W | 0h | 0 = Character replacement is disabled. Data are sent without inserting a frame alignment control character. 1 = If the last octet of the frame is the same as the last octet of the previous frame, then the octet is replaced with /K28.7/. Character replacement is not performed if a control character was already sent in the previous frame; see the JESD204B document., section 5.3.3.4 for details. |
| 10 | LINK_CONFIG_DIS | R/W | 0h | 0 = ILA transmission enabled. The initial lane alignment data are sent, as per section 5.3.3.5 and 8.3 of the JESD204B document. 1 = ILA transmission disabled. The device starts sending payload data immediately after the code group synchronization. |
| 9-3 | 0 | R/W | 0h | Must write 0 |
| 2 | FORCE_K | R/W | 0h | 0 = Value of K (number of frames per multiframe) minus 1 is automatically calculated and set 1 = Value of K (number of frames per multiframe) minus 1 is set by the K_VALUE_TO_FORCE register setting |
| 1-0 | 0 | R/W | 0h | Must write 0 |

12.2.1.3 Register 74 (address = 4Ah)
图 154. Register 74

| | | | | | | | | | | | | | | | |
|----------------------|--|--------|--|-------------|--|-------------|--|--------|--|--------|--|-------------|--|--------|--|
| 15 | | 14 | | 13 | | 12 | | 11 | | 10 | | 9 | | 8 | |
| LINK_LAYER_TESTMODES | | | | TX_SYNC_REQ | | RELEASE_ILA | | | | 0 | | JESD_RESET2 | | | |
| R/W-0h | | | | R/W-0h | | R/W-0h | | | | R/W-0h | | R/W-0h | | | |
| 7 | | 6 | | 5 | | 4 | | 3 | | 2 | | 1 | | 0 | |
| JESD_RESET3 | | 0 | | 0 | | 0 | | 0 | | 0 | | 0 | | 0 | |
| R/W-0h | | R/W-0h | | R/W-0h | | R/W-0h | | R/W-0h | | R/W-0h | | R/W-0h | | R/W-0h | |

LEGEND: R/W = Read/Write; -n = value after reset

表 108. Register 74 Field Descriptions

| Bit | Field | Type | Reset | Description |
|-------|----------------------|------|-------|---|
| 15-13 | LINK_LAYER_TESTMODES | R/W | 0h | 000 = Normal operation 001 = D21.5 (1010101010) is transmitted on all lanes 010 = /K28.5/ is transmitted on all lanes 011 = ILA sequence is continuously transmitted on all lanes 100 = Pseudo-random pattern of 120 bits is transmitted on all lanes All other combinations are invalid. |
| 12 | TX_SYNC_REQ | R/W | 0h | 0 = Sync reinitialization request disabled (normal operation) 1 = A stream of /K28.5/ symbols are transmitted, requesting link reinitialization. After transmission, the /K28.5/ characters enter into a link initialization state; see section 5.3.3.7 of the JESD204B document for further details. |
| 11-10 | RELEASE_ILA | R/W | 0h | 000 = Default value The value of this register determines the LMFC edge that the transmitter enters in the ILA phase from the code group synchronization. This setting is useful for adjusting the deterministic latency value; see the Data Link Layer section. |
| 9 | 0 | R/W | 0h | Must write 0 |
| 8 | JESD_RESET2 | R/W | 0h | 0 = SYNC~ and SYSREF events reset the phase of JESD and non-JESD blocks (demodulator, test pattern generator, and clock dividers) 1 = SYNC~ and SYSREF events do not reset the phase of JESD block and clock dividers but do reset the phase of the demodulator and test pattern generator |
| 7 | JESD_RESET3 | R/W | 0h | 0 = SYNC~ and SYSREF events reset the phase of JESD and non-JESD blocks (demodulator, test pattern generator, and clock dividers) 1 = Immediately after setting this bit to 1, the first SYNC~ and SYSREF event resets the phase of the JESD and non-JESD blocks. Subsequent SYNC~ and SYSREF events do not reset the phase of the JESD block and clock dividers but do reset the phase of the demodulator and test pattern generator. |
| 6-0 | 0 | R/W | 0h | Must write 0 |

12.2.1.4 Register 75 (address = 4Bh)

图 155. Register 75

| | | | | | | | | | | | | | | | |
|------------------|--|--------|--|--------|--|--------|--|--------|--|--------|--|--------|--|-------------------|--|
| 15 | | 14 | | 13 | | 12 | | 11 | | 10 | | 9 | | 8 | |
| 0 | | 0 | | 0 | | 0 | | 0 | | 0 | | 0 | | SING_CONV_PER_OCT | |
| R/W-0h | | R/W-0h | | R/W-0h | | R/W-0h | | R/W-0h | | R/W-0h | | R/W-0h | | R/W-0h | |
| 7 | | 6 | | 5 | | 4 | | 3 | | 2 | | 1 | | 0 | |
| NUM_ADC_PER_LANE | | | | 0 | | 0 | | 0 | | 0 | | 0 | | 0 | |
| R/W-0h | | | | R/W-0h | | R/W-0h | | R/W-0h | | R/W-0h | | R/W-0h | | R/W-0h | |

LEGEND: R/W = Read/Write; -n = value after reset

表 109. Register 75 Field Descriptions

| Bit | Field | Type | Reset | Description |
|------|-------------------|------|-------|---|
| 15-9 | 0 | R/W | 0h | Must write 0 |
| 8 | SING_CONV_PER_OCT | R/W | 0h | 0 = Data are packed efficiently and transmitted over the link 1 = Each ADC data are packed in two octets [that is, each ADC data are transmitted as 16 bits (12-, 14-, and 16-bit mode) by the appropriate zero padding]; see the <i>User Data Format</i> section for further details. |
| 7-5 | NUM_ADC_PER_LANE | R/W | 0h | 000 = Four ADCs per lane mode: data from four ADCs are packed into a lane. Four lanes are active and four lanes are powered down. 001 = Eight ADCs per lane mode: data from eight ADCs are packed into a lane. Two lanes are active and six lanes are powered down. 100 = Two ADCs per lane mode: data from two ADCs are packed into a lane. All eight lanes are active. All other settings are invalid. |
| 4-0 | 0 | R/W | 0h | Must write 0 |

12.2.1.5 Register 77 (address = 4Dh)
图 156. Register 77

| | | | | | | | |
|---------|--------|--------|--------|--------|--------|--------|--------|
| 15 | 14 | 13 | 12 | 11 | 10 | 9 | 8 |
| 0 | 0 | 0 | 0 | 0 | 0 | 0 | 0 |
| R/W-0h | R/W-0h | R/W-0h | R/W-0h | R/W-0h | R/W-0h | R/W-0h | R/W-0h |
| 7 | 6 | 5 | 4 | 3 | 2 | 1 | 0 |
| PRE_EMP | | | | 0 | 0 | 0 | 0 |
| R/W-0h | | | | R/W-0h | R/W-0h | R/W-0h | R/W-0h |

LEGEND: R/W = Read/Write; -n = value after reset

表 110. Register 77 Field Descriptions

| Bit | Field | Type | Reset | Description |
|------|---------|------|-------|---|
| 15-8 | 0 | R/W | 0h | Must write 0 |
| 7-4 | PRE_EMP | R/W | 0h | The extra current during pre-emphasis is equal to the decimal equivalent of the programmed value multiplied by 0.25 mA. A value corresponding to 0 refers to no pre-emphasis. |
| 3-0 | 0 | R/W | 0h | Must write 0 |

12.2.1.6 Register 80 (address = 50h)
图 157. Register 80

| | | | | | | | |
|--------|--------|--------|--------|--------|--------|--------------|--------|
| 15 | 14 | 13 | 12 | 11 | 10 | 9 | 8 |
| 0 | 0 | 0 | 0 | 0 | 0 | 0 | 0 |
| R/W-0h | R/W-0h | R/W-0h | R/W-0h | R/W-0h | R/W-0h | R/W-0h | R/W-0h |
| 7 | 6 | 5 | 4 | 3 | 2 | 1 | 0 |
| 0 | 0 | 0 | 0 | 0 | 0 | INC_JESD_VDD | 0 |
| R/W-0h | R/W-0h | R/W-0h | R/W-0h | R/W-0h | R/W-0h | R/W-0h | R/W-0h |

LEGEND: R/W = Read/Write; -n = value after reset

表 111. Register 80 Field Descriptions

| Bit | Field | Type | Reset | Description |
|------|--------------|------|-------|--|
| 15-2 | 0 | R/W | 0h | Must write 0 |
| 1 | INC_JESD_VDD | R/W | 0h | 0 = Default value for the internal LDO driving the JESD PLL 1 = Increased value for the internal LDO driving the JESD PLL |
| 0 | 0 | R/W | 0h | Must write 0 |

12.2.1.7 Register 81 (address = 51h)

图 158. Register 81

| | | | | | | | | |
|-----------|--------|--------|---------|----|----|---|---|--|
| 15 | 14 | 13 | 12 | 11 | 10 | 9 | 8 | |
| DEVICE_ID | | | | | | | | |
| R/W-0h | | | | | | | | |
| 7 | 6 | 5 | 4 | 3 | 2 | 1 | 0 | |
| 0 | 0 | 0 | BANK_ID | | | | | |
| R/W-0h | R/W-0h | R/W-0h | R/W-0h | | | | | |

LEGEND: R/W = Read/Write; -n = value after reset

表 112. Register 81 Field Descriptions

| Bit | Field | Type | Reset | Description |
|------|-----------|------|-------|---------------------------------------|
| 15-8 | DEVICE_ID | R/W | 0h | These bits force the device ID value. |
| 7-5 | 0 | R/W | 0h | Must write 0 |
| 4-0 | BANK_ID | R/W | 0h | These bits force the bank ID value. |

12.2.1.8 Register 82 (address = 52h)

图 159. Register 82

| | | | | | | | |
|--------|--------|--------|--------|--------|--------|--------|--------|
| 15 | 14 | 13 | 12 | 11 | 10 | 9 | 8 |
| 0 | 0 | 0 | 0 | 0 | 0 | 0 | 0 |
| R/W-0h | R/W-0h | R/W-0h | R/W-0h | R/W-0h | R/W-0h | R/W-0h | R/W-0h |
| 7 | 6 | 5 | 4 | 3 | 2 | 1 | 0 |
| SCR_EN | 0 | 0 | 0 | 0 | 0 | 0 | 0 |
| R/W-0h | R/W-0h | R/W-0h | R/W-0h | R/W-0h | R/W-0h | R/W-0h | R/W-0h |

LEGEND: R/W = Read/Write; -n = value after reset

表 113. Register 82 Field Descriptions

| Bit | Field | Type | Reset | Description |
|------|--------|------|-------|--|
| 15-8 | 0 | R/W | 0h | Must write 0 |
| 7 | SCR_EN | R/W | 0h | 0 = Scrambler disabled 1 = Scrambler enabled; see the Scrambler section for further details |
| 6-0 | 0 | R/W | 0h | Must write 0 |

12.2.1.9 Register 83 (address = 53h)
图 160. Register 83

| | | | | | | | | |
|--------|--------|--------|------------------|--------|--------|--------|--------|--|
| 15 | 14 | 13 | 12 | 11 | 10 | 9 | 8 | |
| 0 | 0 | 0 | 0 | 0 | 0 | 0 | 0 | |
| R/W-0h | R/W-0h | R/W-0h | R/W-0h | R/W-0h | R/W-0h | R/W-0h | R/W-0h | |
| 7 | 6 | 5 | 4 | 3 | 2 | 1 | 0 | |
| 0 | 0 | 0 | K_VALUE_TO_FORCE | | | | | |
| R/W-0h | R/W-0h | R/W-0h | R/W-0h | | | | | |

LEGEND: R/W = Read/Write; -n = value after reset

表 114. Register 83 Field Descriptions

| Bit | Field | Type | Reset | Description |
|------|------------------|------|-------|---|
| 15-5 | 0 | R/W | 0h | Must write 0 |
| 4-0 | K_VALUE_TO_FORCE | R/W | 0h | Specifies the value of K (number of frames per multiframe) minus 1 to be forced when the FORCE_K bit is set to 1. |

12.2.1.10 Register 85 (address = 55h)
图 161. Register 85

| | | | | | | | |
|---------------|----|----|--------|--------|--------|--------|--------|
| 15 | 14 | 13 | 12 | 11 | 10 | 9 | 8 |
| JESD_SUBCLASS | | | 0 | 0 | 0 | 0 | 0 |
| R/W-0h | | | R/W-0h | R/W-0h | R/W-0h | R/W-0h | R/W-0h |
| 7 | 6 | 5 | 4 | 3 | 2 | 1 | 0 |
| JESD_VER | | | 0 | 0 | 0 | 0 | 0 |
| R/W-0h | | | R/W-0h | R/W-0h | R/W-0h | R/W-0h | R/W-0h |

LEGEND: R/W = Read/Write; -n = value after reset

表 115. Register 85 Field Descriptions

| Bit | Field | Type | Reset | Description |
|-------|---------------|------|-------|--|
| 15-13 | JESD_SUBCLASS | R/W | 0h | 000 = Subclass 0 001 = Subclass 1 010 = subclass 2 See the JESD Version and Subclass section for further details. |
| 12-8 | 0 | R/W | 0h | Must write 0 |
| 7-5 | JESD_VER | R/W | 0h | 000 = JESD204A 001 = JESD204B See the JESD Version and Subclass section for further details. |
| 4-0 | 0 | R/W | 0h | Must write 0 |

12.2.1.11 Register 115 (address = 73h)

图 162. Register 115

| | | | | | | | | | | | | | | | |
|-------------|-------------|-------------|-------------------------|-------------------|-------------------|-------------------|-------------------|--------|--------|--------|--------|--------|--------|--------|--------|
| 15 | | 14 | | 13 | | 12 | | 11 | | 10 | | 9 | | 8 | |
| EN_LANE_ID1 | EN_LANE_ID2 | EN_LANE_ID3 | EN_LANE_ID4 | EN_CHECKSUM_LANE1 | EN_CHECKSUM_LANE2 | EN_CHECKSUM_LANE3 | EN_CHECKSUM_LANE4 | R/W-0h | R/W-0h | R/W-0h | R/W-0h | R/W-0h | R/W-0h | R/W-0h | R/W-0h |
| 7 | | 6 | | 5 | | 4 | | 3 | | 2 | | 1 | | 0 | |
| 0 | 0 | 0 | ENABLE_JESD_VER_CONTROL | 0 | 0 | 0 | 0 | R/W-0h | R/W-0h | R/W-0h | R/W-0h | R/W-0h | R/W-0h | R/W-0h | R/W-0h |

LEGEND: R/W = Read/Write; -n = value after reset

表 116. Register 115 Field Descriptions

| Bit | Field | Type | Reset | Description |
|-----|-------------------------|------|-------|--|
| 15 | EN_LANE_ID1 | R/W | 0h | 0 = Lane 1 default ID (00001) is set 1 = Lane 1 default ID (00001) can be forced with register 118, bits 12-8 |
| 14 | EN_LANE_ID2 | R/W | 0h | 0 = Lane 2 default ID (00010) is set 1 = Lane 2 default ID (00010) can be forced with register 118, bits 4-0 |
| 13 | EN_LANE_ID3 | R/W | 0h | 0 = Lane 3 default ID (00011) is set 1 = Lane 3 default ID (00011) can be forced with register 119, bits 12-8 |
| 12 | EN_LANE_ID4 | R/W | 0h | 0 = Lane 4 default ID (00100) is set 1 = Lane 4 default ID (00100) can be forced with register 119, bits 4-0 |
| 11 | EN_CHECKSUM_LANE1 | R/W | 0h | 0 = The default checksum value is calculated by the device 1 = Checksum value (FCHK field in 表 15) is forced from register 116, bits 15-8 |
| 10 | EN_CHECKSUM_LANE2 | R/W | 0h | 0 = The default checksum value is calculated by the device 1 = Checksum value (FCHK field in 表 15) is forced from register 116, bits 7-0 |
| 9 | EN_CHECKSUM_LANE3 | R/W | 0h | 0 = The default checksum value is calculated by the device 1 = Checksum value (FCHK field in 表 15) is forced from register 117, bits 15-8 |
| 8 | EN_CHECKSUM_LANE4 | R/W | 0h | 0 = The default checksum value is calculated by the device 1 = Checksum value (FCHK field in 表 15) is forced from register 117, bits 7-0 |
| 7-5 | 0 | R/W | 0h | Must write 0 |
| 4 | ENABLE_JESD_VER_CONTROL | R/W | 0h | 0 = The device is in JESD204B, subclass 1 mode 1 = JESD version and subclass can be changed; see the 表 15 section for further details. |
| 3-0 | 0 | R/W | 0h | Must write 0 |

12.2.1.12 Register 116 (address = 74h)
图 163. Register 116

| | | | | | | | |
|------------|----|----|----|----|----|---|---|
| 15 | 14 | 13 | 12 | 11 | 10 | 9 | 8 |
| CHECK_SUM1 | | | | | | | |
| R/W-0h | | | | | | | |
| 7 | 6 | 5 | 4 | 3 | 2 | 1 | 0 |
| CHECK_SUM2 | | | | | | | |
| R/W-0h | | | | | | | |

LEGEND: R/W = Read/Write; -n = value after reset

表 117. Register 116 Field Descriptions

| Bit | Field | Type | Reset | Description |
|------|------------|------|-------|--|
| 15-8 | CHECK_SUM1 | R/W | 0h | These bits determine the lane 1 checksum value; see register 135 . |
| 7-0 | CHECK_SUM2 | R/W | 0h | These bits determine the lane 2 checksum value; see register 135 . |

12.2.1.13 Register 117 (address = 75h)
图 164. Register 117

| | | | | | | | |
|------------|----|----|----|----|----|---|---|
| 15 | 14 | 13 | 12 | 11 | 10 | 9 | 8 |
| CHECK_SUM3 | | | | | | | |
| R/W-0h | | | | | | | |
| 7 | 6 | 5 | 4 | 3 | 2 | 1 | 0 |
| CHECK_SUM4 | | | | | | | |
| R/W-0h | | | | | | | |

LEGEND: R/W = Read/Write; -n = value after reset

表 118. Register 117 Field Descriptions

| Bit | Field | Type | Reset | Description |
|------|------------|------|-------|--|
| 15-8 | CHECK_SUM3 | R/W | 0h | These bits determine the lane 3 checksum value; see register 136 . |
| 7-0 | CHECK_SUM4 | R/W | 0h | These bits determine the lane 4 checksum value; see register 136 . |

12.2.1.14 Register 118 (address = 76h)

图 165. Register 118

| | | | | | | | |
|--------|--------|--------|----------|----|----|---|---|
| 15 | 14 | 13 | 12 | 11 | 10 | 9 | 8 |
| 0 | 0 | 0 | LANE_ID1 | | | | |
| R/W-0h | R/W-0h | R/W-0h | R/W-0h | | | | |
| 7 | 6 | 5 | 4 | 3 | 2 | 1 | 0 |
| 0 | 0 | 0 | LANE_ID2 | | | | |
| R/W-0h | R/W-0h | R/W-0h | R/W-0h | | | | |

LEGEND: R/W = Read/Write; -n = value after reset

表 119. Register 118 Field Descriptions

| Bit | Field | Type | Reset | Description |
|-------|----------|------|-------|--|
| 15-13 | 0 | R/W | 0h | Must write 0 |
| 12-8 | LANE_ID1 | R/W | 0h | These bits determine the lane 1 ID value; see register 137 . |
| 7-5 | 0 | R/W | 0h | Must write 0 |
| 4-0 | LANE_ID2 | R/W | 0h | These bits determine the lane 2 ID value; see register 137 . |

12.2.1.15 Register 119 (address = 77h)

图 166. Register 119

| | | | | | | | |
|--------|--------|--------|----------|----|----|---|---|
| 15 | 14 | 13 | 12 | 11 | 10 | 9 | 8 |
| 0 | 0 | 0 | LANE_ID3 | | | | |
| R/W-0h | R/W-0h | R/W-0h | R/W-0h | | | | |
| 7 | 6 | 5 | 4 | 3 | 2 | 1 | 0 |
| 0 | 0 | 0 | LANE_ID4 | | | | |
| R/W-0h | R/W-0h | R/W-0h | R/W-0h | | | | |

LEGEND: R/W = Read/Write; -n = value after reset

表 120. Register 119 Field Descriptions

| Bit | Field | Type | Reset | Description |
|-------|----------|------|-------|--|
| 15-13 | 0 | R/W | 0h | Must write 0 |
| 12-8 | LANE_ID3 | R/W | 0h | These bits determine the lane 3 ID value; see register 138 . |
| 7-5 | 0 | R/W | 0h | Must write 0 |
| 4-0 | LANE_ID4 | R/W | 0h | These bits determine the lane 4 ID value; see register 138 . |

12.2.1.16 Register 120 (address = 78h)
图 167. Register 120

| | | | | | | | |
|------------------|-------------------------|--------|--------|--------|--------|--------|--------|
| 15 | 14 | 13 | 12 | 11 | 10 | 9 | 8 |
| FORCE_LMFC_COUNT | LMFC_COUNTER_INIT_VALUE | | | | | 0 | 0 |
| R/W-0h | R/W-0h | | | | | R/W-0h | R/W-0h |
| 7 | 6 | 5 | 4 | 3 | 2 | 1 | 0 |
| 0 | 0 | 0 | 0 | 0 | 0 | 0 | 0 |
| R/W-0h | R/W-0h | R/W-0h | R/W-0h | R/W-0h | R/W-0h | R/W-0h | R/W-0h |

LEGEND: R/W = Read/Write; -n = value after reset

表 121. Register 120 Field Descriptions

| Bit | Field | Type | Reset | Description |
|-------|-------------------------|------|-------|--|
| 15 | FORCE_LMFC_COUNT | R/W | 0h | 0 = Default value 1 = The LMFC counter value is forced, as per register 120, bits 14-10. |
| 14-10 | LMFC_COUNTER_INIT_VALUE | R/W | 0h | These bits specify the initial value of the LMFC counter. This option is useful when the multiframe size must be different than the default value; see the Synchronization Using SYNC~ and SYSREF section. |
| 9-0 | 0 | R/W | 0h | Must write 0 |

12.2.1.17 Register 134 (address = 86h)

图 168. Register 134

| | | | | | | | | | | | | | | | |
|-------------|--|-------------|--|-------------|--|-------------|--|-------------------|--|-------------------|--|-------------------|--|-------------------|--|
| 15 | | 14 | | 13 | | 12 | | 11 | | 10 | | 9 | | 8 | |
| EN_LANE_ID5 | | EN_LANE_ID6 | | EN_LANE_ID7 | | EN_LANE_ID8 | | EN_CHECKSUM_LANE5 | | EN_CHECKSUM_LANE6 | | EN_CHECKSUM_LANE7 | | EN_CHECKSUM_LANE8 | |
| R/W-0h | | R/W-0h | | R/W-0h | | R/W-0h | | R/W-0h | | R/W-0h | | R/W-0h | | R/W-0h | |
| 7 | | 6 | | 5 | | 4 | | 3 | | 2 | | 1 | | 0 | |
| 0 | | 0 | | 0 | | 0 | | 0 | | 0 | | 0 | | 0 | |
| R/W-0h | | R/W-0h | | R/W-0h | | R/W-0h | | R/W-0h | | R/W-0h | | R/W-0h | | R/W-0h | |

LEGEND: R/W = Read/Write; -n = value after reset

- (1) This register is valid when JESD_WR_SEL (register 3, bit 5) is 1.

表 122. Register 134 Field Descriptions

| Bit | Field | Type | Reset | Description |
|-----|-------------------|------|-------|--|
| 15 | EN_LANE_ID5 | R/W | 0h | 0 = Lane 5 default ID (00101) is set 1 = Lane 5 default ID (00101) can be forced with register 137, bits 12-8 |
| 14 | EN_LANE_ID6 | R/W | 0h | 0 = Lane 6 default ID (00110) is set 1 = Lane 6 default ID (00110) can be forced with register 137, bits 4-0 |
| 13 | EN_LANE_ID7 | R/W | 0h | 0 = Lane 7 default ID (00111) is set 1 = Lane 7 default ID (00111) can be forced with register 138, bits 12-8 |
| 12 | EN_LANE_ID8 | R/W | 0h | 0 = Lane 8 default ID (01000) is set 1 = Lane 8 default ID (01000) can be forced with register 138, bits 4-0 |
| 11 | EN_CHECKSUM_LANE5 | R/W | 0h | 0 = Default checksum value calculated by device 1 = Checksum value (FCHK field in 表 15) from register 135, bits 15-8 |
| 10 | EN_CHECKSUM_LANE6 | R/W | 0h | 0 = The default checksum value is calculated by the device 1 = Checksum value (FCHK field in 表 15) from register 135, bits 7-0 |
| 9 | EN_CHECKSUM_LANE7 | R/W | 0h | 0 = The default checksum value is calculated by the device 1 = Checksum value (FCHK field in 表 15) from register 135, bits 15-8 |
| 8 | EN_CHECKSUM_LANE8 | R/W | 0h | 0 = The default checksum value is calculated by the device 1 = Checksum value (FCHK field in 表 15) from register 135, bits 7-0 |
| 7-0 | 0 | R/W | 0h | Must write 0 |

12.2.1.18 Register 135 (address = 87h)

图 169. Register 135

| | | | | | | | | | | | | | | | |
|------------|--|----|--|----|--|----|--|----|--|----|--|---|--|---|--|
| 15 | | 14 | | 13 | | 12 | | 11 | | 10 | | 9 | | 8 | |
| CHECK_SUM5 | | | | | | | | | | | | | | | |
| R/W-0h | | | | | | | | | | | | | | | |
| 7 | | 6 | | 5 | | 4 | | 3 | | 2 | | 1 | | 0 | |
| CHECK_SUM6 | | | | | | | | | | | | | | | |
| R/W-0h | | | | | | | | | | | | | | | |

LEGEND: R/W = Read/Write; -n = value after reset

表 123. Register 135 Field Descriptions

| Bit | Field | Type | Reset | Description |
|------|------------|------|-------|---|
| 15-8 | CHECK_SUM5 | R/W | 0h | These bits determine the lane 5 checksum value. |
| 7-0 | CHECK_SUM6 | R/W | 0h | These bits determine the lane 6 checksum value. |

12.2.1.19 Register 136 (address = 88h)
图 170. Register 136

| | | | | | | | |
|------------|----|----|----|----|----|---|---|
| 15 | 14 | 13 | 12 | 11 | 10 | 9 | 8 |
| CHECK_SUM7 | | | | | | | |
| R/W-0h | | | | | | | |
| 7 | 6 | 5 | 4 | 3 | 2 | 1 | 0 |
| CHECK_SUM8 | | | | | | | |
| R/W-0h | | | | | | | |

LEGEND: R/W = Read/Write; -n = value after reset

表 124. Register 136 Field Descriptions

| Bit | Field | Type | Reset | Description |
|------|------------|------|-------|---|
| 15-8 | CHECK_SUM7 | R/W | 0h | These bits determine the lane 7 checksum value. |
| 7-0 | CHECK_SUM8 | R/W | 0h | These bits determine the lane 8 checksum value. |

12.2.1.20 Register 137 (address = 89h)
图 171. Register 137

| | | | | | | | |
|--------|--------|--------|----------|----|----|---|---|
| 15 | 14 | 13 | 12 | 11 | 10 | 9 | 8 |
| 0 | 0 | 0 | LANE_ID5 | | | | |
| R/W-0h | R/W-0h | R/W-0h | R/W-0h | | | | |
| 7 | 6 | 5 | 4 | 3 | 2 | 1 | 0 |
| 0 | 0 | 0 | LANE_ID6 | | | | |
| R/W-0h | R/W-0h | R/W-0h | R/W-0h | | | | |

LEGEND: R/W = Read/Write; -n = value after reset

表 125. Register 137 Field Descriptions

| Bit | Field | Type | Reset | Description |
|-------|----------|------|-------|---|
| 15-13 | 0 | R/W | 0h | Must write 0 |
| 12-8 | LANE_ID5 | R/W | 0h | These bits determine the lane 5 ID value. |
| 7-5 | 0 | R/W | 0h | Must write 0 |
| 4-0 | LANE_ID6 | R/W | 0h | These bits determine the lane 6 ID value. |

12.2.1.21 Register 138 (address = 8Ah)
图 172. Register 138

| | | | | | | | |
|--------|--------|--------|----------|----|----|---|---|
| 15 | 14 | 13 | 12 | 11 | 10 | 9 | 8 |
| 0 | 0 | 0 | LANE_ID7 | | | | |
| R/W-0h | R/W-0h | R/W-0h | R/W-0h | | | | |
| 7 | 6 | 5 | 4 | 3 | 2 | 1 | 0 |
| 0 | 0 | 0 | LANE_ID8 | | | | |
| R/W-0h | R/W-0h | R/W-0h | R/W-0h | | | | |

LEGEND: R/W = Read/Write; -n = value after reset

表 126. Register 138 Field Descriptions

| Bit | Field | Type | Reset | Description |
|-------|----------|------|-------|---|
| 15-13 | 0 | R/W | 0h | Must write 0 |
| 12-8 | LANE_ID7 | R/W | 0h | These bits determine the lane 7 ID value. |
| 7-5 | 0 | R/W | 0h | Must write 0 |
| 4-0 | LANE_ID8 | R/W | 0h | These bits determine the lane 8 ID value. |

13 器件和文档支持

13.1 文档支持

13.1.1 相关文档

《CDCE72010 数据表》，[SCAS858](#)

《CDCM7005 数据表》，[SCAS793](#)

《LMK048X 数据表》，[SNAS605](#)

《SN74AUP1T04 数据表》，[SCES800](#)

《高速时钟数据转换器》，[SLYT075](#)

13.2 社区资源

下列链接提供到 TI 社区资源的连接。链接的内容由各个分销商“按照原样”提供。这些内容并不构成 TI 技术规范，并且不一定反映 TI 的观点；请参阅 TI 的《[使用条款](#)》。

TI E2E™ 在线社区 *TI 的工程师对工程师 (E2E) 社区*。此社区的创建目的在于促进工程师之间的协作。在 [e2e.ti.com](#) 中，您可以咨询问题、分享知识、拓展思路并与同行工程师一道帮助解决问题。

设计支持 *TI 参考设计支持* 可帮助您快速查找有帮助的 E2E 论坛、设计支持工具以及技术支持的联系信息。

13.3 商标

E2E is a trademark of Texas Instruments.

All other trademarks are the property of their respective owners.

13.4 静电放电警告



这些装置包含有限的内置 ESD 保护。存储或装卸时，应将导线一起截短或将装置放置于导电泡棉中，以防止 MOS 门极遭受静电损伤。

13.5 术语表

SLYZ022 — *TI 术语表*。

这份术语表列出并解释术语、缩写和定义。

14 机械、封装和可订购信息

以下页面包含机械、封装和可订购信息。这些信息是指定器件的最新可用数据。数据如有变更，恕不另行通知，且不会对此文档进行修订。如需获取此数据表的浏览器版本，请参阅左侧的导航栏。

MECHANICAL DATA

ZZE (R-PBGA-N198)

PLASTIC BALL GRID ARRAY

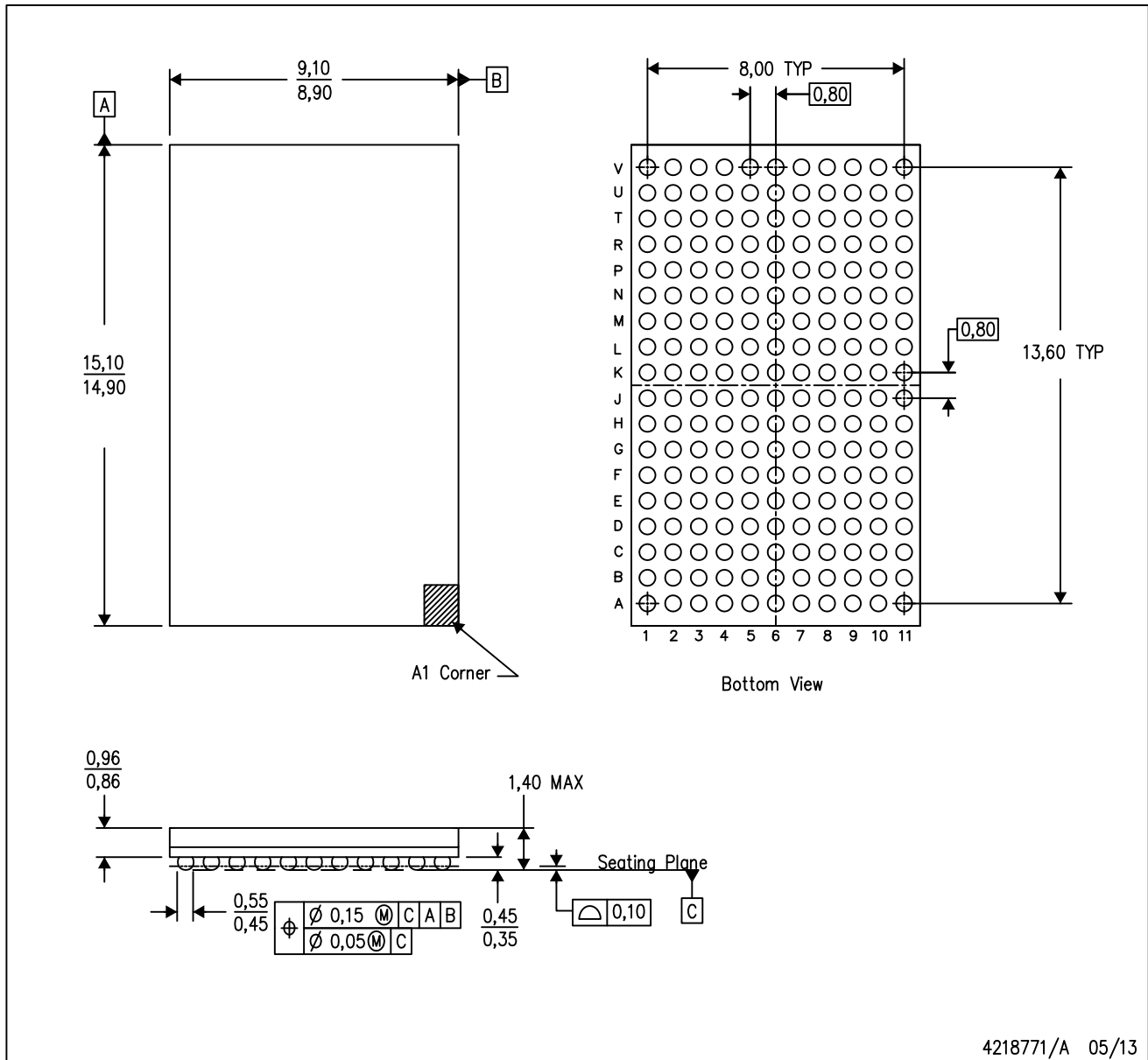

- NOTES:
- A. All linear dimensions are in millimeters. Dimensioning and tolerancing per ASME Y14.5M-1994.
 - B. This drawing is subject to change without notice.
 - C. This is a Pb-free solder ball design.

PACKAGING INFORMATION

| Orderable Device | Status (1) | Package Type | Package Drawing | Pins | Package Qty | Eco Plan (2) | Lead finish/ Ball material (6) | MSL Peak Temp (3) | Op Temp (°C) | Device Marking (4/5) | Samples |
|------------------|---------------|--------------|-----------------|------|-------------|-----------------|--------------------------------------|----------------------|--------------|-------------------------|---------|
| ADS52J90ZZE | ACTIVE | NFBGA | ZZE | 198 | 160 | RoHS & Green | SNAGCU | Level-3-260C-168 HR | -40 to 85 | ADS52J90 | Samples |

(1) The marketing status values are defined as follows:

ACTIVE: Product device recommended for new designs.

LIFEBUY: TI has announced that the device will be discontinued, and a lifetime-buy period is in effect.

NRND: Not recommended for new designs. Device is in production to support existing customers, but TI does not recommend using this part in a new design.

PREVIEW: Device has been announced but is not in production. Samples may or may not be available.

OBSOLETE: TI has discontinued the production of the device.

(2) **RoHS:** TI defines "RoHS" to mean semiconductor products that are compliant with the current EU RoHS requirements for all 10 RoHS substances, including the requirement that RoHS substance do not exceed 0.1% by weight in homogeneous materials. Where designed to be soldered at high temperatures, "RoHS" products are suitable for use in specified lead-free processes. TI may reference these types of products as "Pb-Free".

RoHS Exempt: TI defines "RoHS Exempt" to mean products that contain lead but are compliant with EU RoHS pursuant to a specific EU RoHS exemption.

Green: TI defines "Green" to mean the content of Chlorine (Cl) and Bromine (Br) based flame retardants meet JS709B low halogen requirements of <=1000ppm threshold. Antimony trioxide based flame retardants must also meet the <=1000ppm threshold requirement.

(3) MSL, Peak Temp. - The Moisture Sensitivity Level rating according to the JEDEC industry standard classifications, and peak solder temperature.

(4) There may be additional marking, which relates to the logo, the lot trace code information, or the environmental category on the device.

(5) Multiple Device Markings will be inside parentheses. Only one Device Marking contained in parentheses and separated by a "-" will appear on a device. If a line is indented then it is a continuation of the previous line and the two combined represent the entire Device Marking for that device.

(6) Lead finish/Ball material - Orderable Devices may have multiple material finish options. Finish options are separated by a vertical ruled line. Lead finish/Ball material values may wrap to two lines if the finish value exceeds the maximum column width.

Important Information and Disclaimer:The information provided on this page represents TI's knowledge and belief as of the date that it is provided. TI bases its knowledge and belief on information provided by third parties, and makes no representation or warranty as to the accuracy of such information. Efforts are underway to better integrate information from third parties. TI has taken and continues to take reasonable steps to provide representative and accurate information but may not have conducted destructive testing or chemical analysis on incoming materials and chemicals. TI and TI suppliers consider certain information to be proprietary, and thus CAS numbers and other limited information may not be available for release.

In no event shall TI's liability arising out of such information exceed the total purchase price of the TI part(s) at issue in this document sold by TI to Customer on an annual basis.

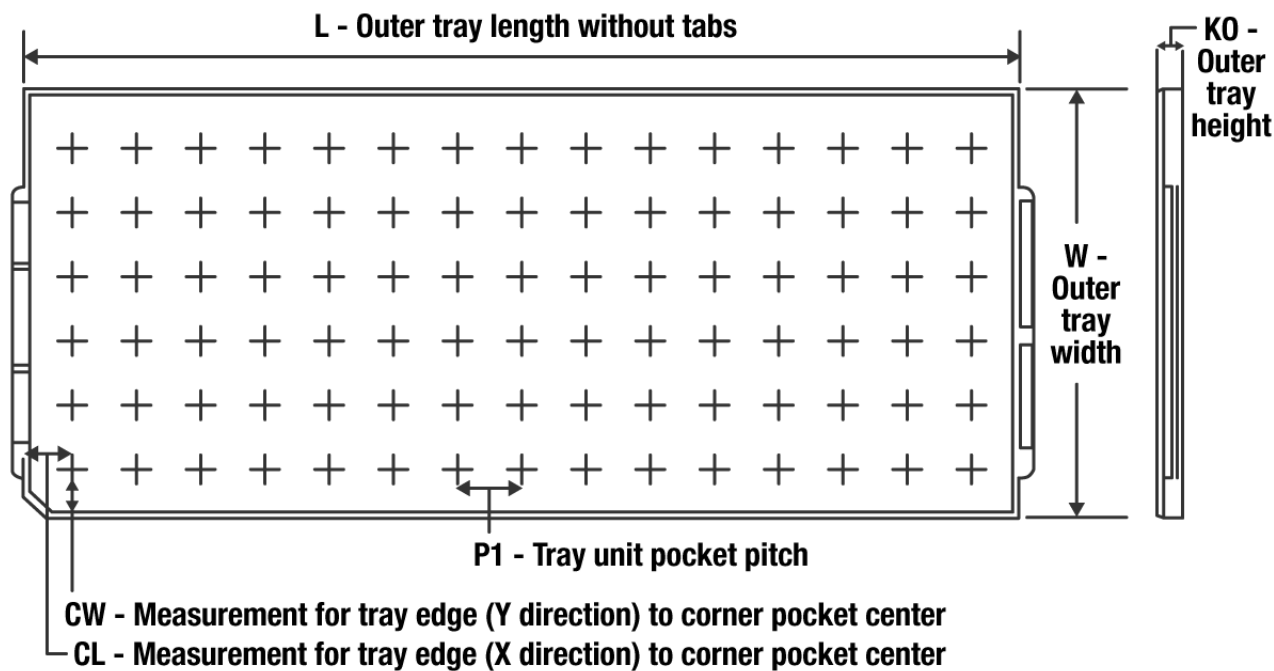
TRAY

Chamfer on Tray corner indicates Pin 1 orientation of packed units.

*All dimensions are nominal

| Device | Package Name | Package Type | Pins | SPQ | Unit array matrix | Max temperature (°C) | L (mm) | W (mm) | K0 (µm) | P1 (mm) | CL (mm) | CW (mm) |
|-------------|--------------|--------------|------|-----|-------------------|----------------------|--------|--------|---------|---------|---------|---------|
| ADS52J90ZZE | ZZE | NFBGA | 198 | 160 | 10 x 16 | 150 | 315 | 135.9 | 7620 | 19.2 | 13.5 | 10.35 |

重要声明和免责声明

TI“按原样”提供技术和可靠性数据（包括数据表）、设计资源（包括参考设计）、应用或其他设计建议、网络工具、安全信息和其他资源，不保证没有瑕疵且不做任何明示或暗示的担保，包括但不限于对适销性、某特定用途方面的适用性或不侵犯任何第三方知识产权的暗示担保。

这些资源可供使用 TI 产品进行设计的熟练开发人员使用。您将自行承担以下全部责任：(1) 针对您的应用选择合适的 TI 产品，(2) 设计、验证并测试您的应用，(3) 确保您的应用满足相应标准以及任何其他功能安全、信息安全、监管或其他要求。

这些资源如有变更，恕不另行通知。TI 授权您仅可将这些资源用于研发本资源所述的 TI 产品的应用。严禁对这些资源进行其他复制或展示。您无权使用任何其他 TI 知识产权或任何第三方知识产权。您应全额赔偿因在这些资源的使用中对 TI 及其代表造成的任何索赔、损害、成本、损失和债务，TI 对此概不负责。

TI 提供的产品受 [TI 的销售条款](#) 或 [ti.com](#) 上其他适用条款/TI 产品随附的其他适用条款的约束。TI 提供这些资源并不会扩展或以其他方式更改 TI 针对 TI 产品发布的适用的担保或担保免责声明。

TI 反对并拒绝您可能提出的任何其他或不同的条款。

邮寄地址：Texas Instruments, Post Office Box 655303, Dallas, Texas 75265

Copyright © 2022，德州仪器 (TI) 公司