

# ADS126x精密 5 通道和 10 通道 40kSPS 24 位 $\Delta$ - $\Sigma$ ADC

## 1 特性

- 24 位高精度 ADC
  - 温漂: 1nV/°C
  - 增益漂移: 0.5ppm/°C
  - 噪声: 30nV<sub>RMS</sub> (20SPS, 增益 = 128)
  - 线性度: 2ppm
- CMOS PGA 增益: 1 至 128
- 宽输入电压范围:  $\pm 7$ mV 至  $\pm 5$ V
- 数据速率: 2.5SPS 至 40kSPS
- 2.5V 基准: 2ppm/°C
- 同步 50Hz 和 60Hz 抑制模式
- 单周期稳定模式
- 信号和基准监控器
- 5V 或  $\pm 2.5$ V 电源
- 内部温度传感器
- 循环冗余校验 (CRC)
- 激励电流源
- 传感器烧毁电流源
- 四路通用输入/输出 (ADS1261)
- 用于桥式传感器的交流激励 (ADS1261)
- 5mm x 5mm VQFN 封装

## 2 应用

- PLC 模拟输入模块
- 称重秤和应变仪数字转换器
- 温度、压力测量
- 实验室仪表
- 过程分析

## 3 说明

ADS1260 和 ADS1261(ADS126x) 均为包含可编程增益放大器 (PGA) 的精密 40kSPS  $\Delta$ - $\Sigma$  模数转换器 (ADC)。这些器件还包含精密的电压基准和内部故障监控器。这些支持传感器的 ADC 可以为要求最严苛的测量 (包括称重秤和电阻式温度检测器 (RTD)) 提供高精度单芯片解决方案。

这些 ADC 包含输入信号多路复用器、低噪声 PGA (提供 1 至 128 的增益)、4 位  $\Delta$ - $\Sigma$  调制器、精密电压基准和可编程数字滤波器。

高阻抗 PGA 输入 (1G $\Omega$ ) 可减小由传感器负载导致的测量误差。ADS1260 支持三路差分输入或五路单端输入。ADS1261 支持五路差分输入或十路单端输入。集成式电流源可简化 RTD 测量。

灵活的数字滤波器可针对单周期稳定转换进行编程, 同时能够提供同步 50Hz 和 60Hz 线路周期抑制。信号和基准监控器、温度传感器和 CRC 数据验证可增强数据可靠性。

ADS126x 是引脚兼容的器件, 采用 5mm x 5mm VQFN 封装, 额定工作温度范围为  $-40^{\circ}\text{C}$  至  $+125^{\circ}\text{C}$ 。

### 器件信息<sup>(1)</sup>

器件型号	封装	封装尺寸 (标称值)
ADS126x	VQFN (32)	5.0mm x 5.0mm

(1) 如需了解所有可用封装, 请参阅产品说明书末尾的封装选项附录。

### 框图

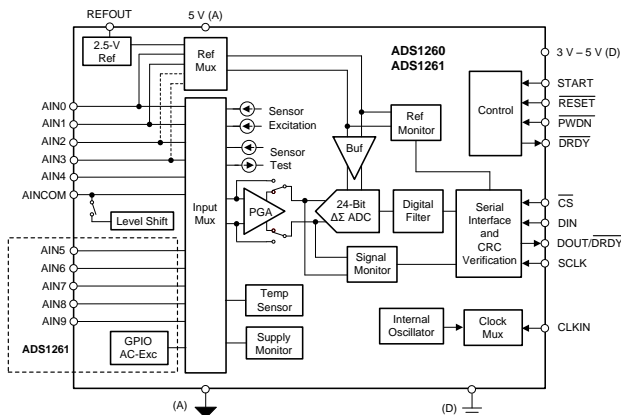

## 目录

1	特性 .....	1	9.5	Programming.....	50
2	应用 .....	1	9.6	Register Map.....	59
3	说明 .....	1	<b>10</b>	<b>Application and Implementation.....</b>	<b>72</b>
4	修订历史记录 .....	2	10.1	Application Information.....	72
5	<b>Device Comparison Table.....</b>	<b>4</b>	10.2	Typical Application .....	76
6	<b>Pin Configuration and Functions .....</b>	<b>4</b>	10.3	Initialization Setup .....	79
7	<b>Specifications.....</b>	<b>6</b>	<b>11</b>	<b>Power Supply Recommendations .....</b>	<b>80</b>
7.1	Absolute Maximum Ratings .....	6	11.1	Power-Supply Decoupling.....	80
7.2	ESD Ratings.....	6	11.2	Analog Power-Supply Clamp .....	80
7.3	Recommended Operating Conditions.....	7	11.3	Power-Supply Sequencing.....	80
7.4	Thermal Information .....	7	<b>12</b>	<b>Layout.....</b>	<b>81</b>
7.5	Electrical Characteristics.....	8	12.1	Layout Guidelines .....	81
7.6	Timing Requirements .....	11	12.2	Layout Example .....	81
7.7	Switching Characteristics .....	12	<b>13</b>	<b>器件和文档支持 .....</b>	<b>83</b>
7.8	Typical Characteristics.....	15	13.1	文档支持 .....	83
<b>8</b>	<b>Parameter Measurement Information .....</b>	<b>22</b>	13.2	相关链接 .....	83
8.1	Noise Performance .....	22	13.3	接收文档更新通知 .....	83
<b>9</b>	<b>Detailed Description .....</b>	<b>26</b>	13.4	社区资源 .....	83
9.1	Overview .....	26	13.5	商标 .....	83
9.2	Functional Block Diagram .....	27	13.6	静电放电警告.....	83
9.3	Feature Description.....	28	13.7	术语表 .....	83
9.4	Device Functional Modes.....	43	<b>14</b>	<b>机械、封装和可订购信息.....</b>	<b>84</b>

## 4 修订历史记录

Changes from Revision B (October 2018) to Revision C	Page
• 已更改 Figure 14, Offset Voltage Long-Term Drift to include 2000-hour data .....	15
• 已更改 Figure 31, Voltage Reference Long-Term Drift to include 2000-hour data .....	17
• 已更改 CRC polynomial to correct listing error: changed <i>CRC-8-ATM (HEC): <math>X^8 + X^2 + X^0 + 1</math></i> to <i>CRC-8-ATM (HEC): <math>X^8 + X^2 + X^1 + 1</math></i> .....	52

Changes from Revision A (May 2018) to Revision B	Page
• 已添加 在产品说明书中添加了 ADS1261 器件 .....	1
• 已更改 将 ADS1260 器件从预览更改成了生产数据（有效） .....	1
• Added connection options to NC pins .....	5
• Added differential input current specification for gain = 128 in <i>Electrical Characteristics</i> .....	8
• Added no missing codes specification in <i>Electrical Characteristics</i> .....	8
• Changed integral nonlinearity specification for gain 64 and 128 in <i>Electrical Characteristics</i> .....	8
• Changed integral nonlinearity specification for 40 kSPS mode in <i>Electrical Characteristics</i> .....	8
• Added offset voltage long-term drift in <i>Electrical Characteristics</i> .....	8
• Added note for PSRR calculation in <i>Electrical Characteristics</i> .....	8
• Changed voltage reference inputs specification in <i>Electrical Characteristics</i> based on updated characteristics .....	9
• Added voltage reference initial error specification for ADS1260B and ADS1261B in <i>Electrical Characteristics</i> .....	9
• Added voltage reference temperature drift specification for ADS1260B and ADS1261B in <i>Electrical Characteristics</i> .....	9
• Added voltage reference long-term drift in <i>Electrical Characteristics</i> .....	9
• Added voltage reference thermal hysteresis in <i>Electrical Characteristics</i> .....	9
• Changed $t_{n(SCDO2)}$ specification in <i>Switching Characteristics</i> .....	12
• Changed $t_{p(SCDO2)}$ specification in <i>Switching Characteristics</i> .....	12

• 已添加 Figure 14, Offset Voltage Long-Term Drift .....	15
• 已更改 Figure 24, Conversion Data Histogram (gain = 4) to 8192 data points .....	16
• 已更改 Figure 25, Conversion Data Histogram (gain = 128) to 8192 data points .....	16
• 已更改 Figure 27, Integral Nonlinearity vs Temperature based on updated characteristics .....	17
• 已更改 Figure 28, Integral Nonlinearity Distribution to add gain = 128 .....	17
• 已更改 Figure 29, Integral Nonlinearity vs Reference Voltage to add gain = 64 and 128 .....	17
• 已添加 Figure 30, Voltage Reference vs Temperature for ADS1260B, ADS1261B .....	17
• 已添加 Figure 31, Voltage Reference Long-Term Drift .....	17
• 已更改 Figure 32, Reference Input Current vs Reference Voltage based on updated characteristics .....	17
• 已添加 Figure 39, CMRR vs Frequency .....	19
• 已添加 Figure 40, PSRR vs Frequency .....	19
• 已添加 text for Table 2, Effective Resolution (Noise-Free Resolution) .....	22
• 已更改 Table 2, Effective Resolution (Noise-Free Resolution) based on updated characteristics .....	24

**Changes from Original (March 2018) to Revision A**
**Page**

• 已更改 将 ADS1261 器件从预告信息更改成了生产数据（有效） .....	1
---	---

## 5 Device Comparison Table

PART NUMBER	CHANNELS <sup>(1)</sup>		VOLTAGE REFERENCE GRADE	REFERENCE INPUTS	GPIO AC EXCITATION
	SINGLE-ENDED	DIFFERENTIAL			
ADS1260B <sup>(2)</sup>	5	3	12 ppm/°C max	1	—
ADS1261B	10	5	12 ppm/°C max	2	4
ADS1261	10	5	40 ppm/°C max	2	4

- (1) Reference inputs, GPIOs, and AC-excitation outputs are multiplexed with the analog input channels.  
 (2) The ADS1260 is available in B grade only.

## 6 Pin Configuration and Functions

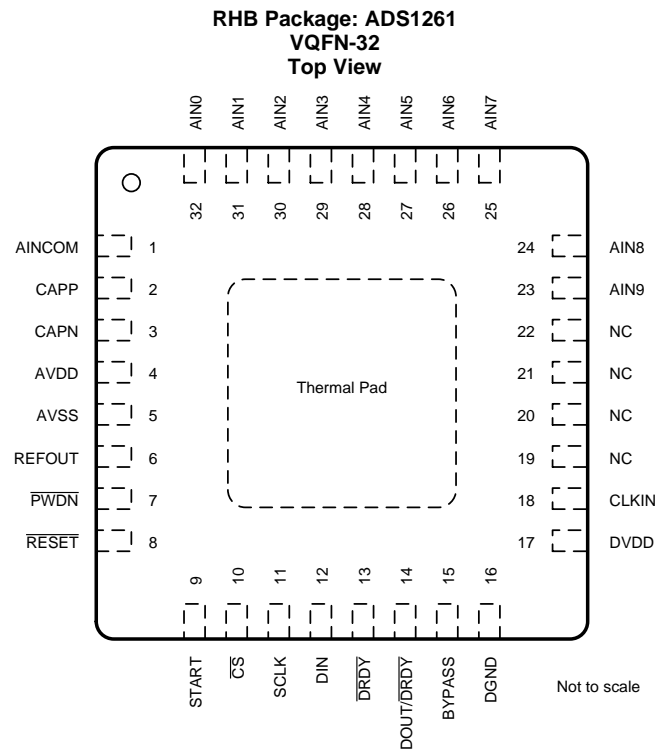
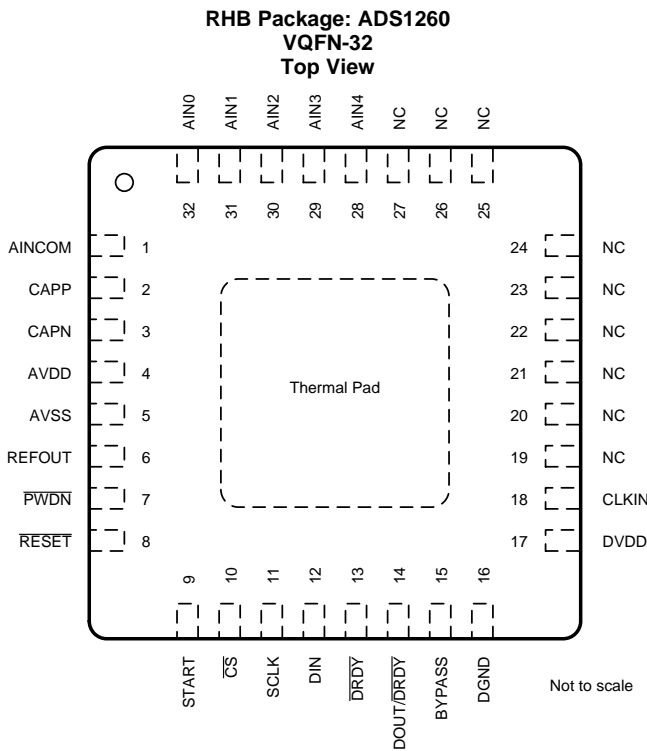

### Pin Functions

NO.	PIN		TYPE	DESCRIPTION
	ADS1260	ADS1261		
1	AINCOM	AINCOM	Analog input/output	Analog input common, IDAC1, IDAC2, VBIAS
2	CAPP	CAPP	Analog output	PGA output P; connect a 4.7-nF C0G dielectric capacitor across CAPP and CAPN
3	CAPN	CAPN	Analog output	PGA output N; connect a 4.7-nF C0G dielectric capacitor across CAPP and CAPN
4	AVDD	AVDD	Analog	Positive analog power supply
5	AVSS	AVSS	Analog	Negative analog power supply
6	REFOUT	REFOUT	Analog output	Internal 2.5-V reference output; connect a 10- $\mu$ F capacitor to AVSS
7	$\overline{\text{PWDN}}$	$\overline{\text{PWDN}}$	Digital input	Power down, active low
8	$\overline{\text{RESET}}$	$\overline{\text{RESET}}$	Digital input	Reset, active low
9	START	START	Digital input	Start conversion control, active high
10	$\overline{\text{CS}}$	$\overline{\text{CS}}$	Digital input	Serial interface chip select, active low
11	SCLK	SCLK	Digital Input	Serial interface shift clock
12	DIN	DIN	Digital Input	Serial interface data input
13	$\overline{\text{DRDY}}$	$\overline{\text{DRDY}}$	Digital output	Data ready indicator, active low
14	$\overline{\text{DOUT/DRDY}}$	$\overline{\text{DOUT/DRDY}}$	Digital output	Dual function serial interface data output and active-low data ready indicator
15	BYPASS	BYPASS	Analog output	Internal subregulator bypass; connect a 1- $\mu$ F capacitor to DGND
16	DGND	DGND	Digital	Digital ground
17	DVDD	DVDD	Digital	Digital power supply
18	CLKIN	CLKIN	Digital input	1) Internal oscillator: connect to DGND 2) External clock: connect clock input
19-22	NC	NC	—	No connection. Electrically float or connect to DGND
23	NC	AIN9	Analog input/output	ADS1260: No connection. Electrically float or connect to DGND ADS1261: Analog input 9, IDAC1, IDAC2
24	NC	AIN8	Analog input/output	ADS1260: No connection. Electrically float or connect to DGND ADS1261: Analog input 8, IDAC1, IDAC2
25	NC	AIN7	Analog input/output	ADS1260: No connection. Electrically float or connect to DGND ADS1261: Analog input 7, IDAC1, IDAC2
26	NC	AIN6	Analog input/output	ADS1260: No connection. Electrically float or connect to DGND ADS1261: Analog input 6, IDAC1, IDAC2
27	NC	AIN5	Analog input/output	ADS1260: No connection. Electrically float or connect to DGND ADS1261: Analog input 5, IDAC1, IDAC2, GPIO3, ACX2
28	AIN4	AIN4	Analog input/output	ADS1260: Analog input 4, IDAC1, IDAC2 ADS1261: Analog input 4, IDAC1, IDAC2, GPIO2, ACX1
29	AIN3	AIN3	Analog input/output	ADS1260: Analog input 3, IDAC1, IDAC2 ADS1261: Analog input 3, IDAC1, IDAC2, REFN1, GPIO1, $\overline{\text{ACX2}}$
30	AIN2	AIN2	Analog input/output	ADS1260: Analog input 2, IDAC1, IDAC2 ADS1261: Analog input 2, IDAC1, IDAC2, REFP1, GPIO0, $\overline{\text{ACX1}}$
31	AIN1	AIN1	Analog input/output	Analog input 1, IDAC1, IDAC2, REFN0
32	AIN0	AIN0	Analog input/output	Analog input 0, IDAC1, IDAC2, REFP0
Thermal Pad	Pad	Pad	—	Exposed thermal pad; Connect to AVSS. Pad must be soldered for mechanical integrity.

## 7 Specifications

### 7.1 Absolute Maximum Ratings

 see <sup>(1)</sup>

		MIN	MAX	UNIT
Power-supply voltage	AVDD to AVSS	-0.3	7	V
	AVSS to DGND	-3	0.3	
	DVDD to DGND	-0.3	7	
Analog input voltage	AINx	AVSS - 0.3	AVDD + 0.3	V
Digital input voltage	$\overline{CS}$ , SCLK, DIN, DOUT/ $\overline{DRDY}$ , $\overline{DRDY}$ , START, $\overline{RESET}$ , $\overline{PWDN}$ , CLKIN	DGND - 0.3	DVDD + 0.3	V
Input current	Continuous, all pins except power-supply pins <sup>(2)</sup>	-10	10	mA
Temperature	Junction, T <sub>J</sub>		150	°C
	Storage, T <sub>stg</sub>	-60	150	°C

- (1) Stresses beyond those listed under *Absolute Maximum Ratings* may cause permanent damage to the device. These are stress ratings only, which do not imply functional operation of the device at these or any other conditions beyond those indicated under *Recommended Operating Conditions*. Exposure to absolute-maximum-rated conditions for extended periods may affect device reliability.
- (2) Input and output pins are diode-clamped to the internal power supplies. Limit the input current to 10 mA in the event the analog input voltage exceeds AVDD + 0.3 V or AVSS - 0.3 V, or if the digital input voltage exceeds DVDD + 0.3 V or DGND - 0.3 V.

### 7.2 ESD Ratings

			VALUE	UNIT
V <sub>(ESD)</sub>	Electrostatic discharge	Human-body model (HBM), per ANSI/ESDA/JEDEC JS-001 <sup>(1)</sup>	±2000	V
		Charged-device model (CDM), per JEDEC specification JESD22-C101 <sup>(2)</sup>	±500	

- (1) JEDEC document JEP155 states that 500-V HBM allows safe manufacturing with a standard ESD control process.
- (2) JEDEC document JEP157 states that 250-V CDM allows safe manufacturing with a standard ESD control process.

### 7.3 Recommended Operating Conditions

			MIN	NOM	MAX	UNIT
<b>POWER SUPPLY</b>						
	Analog power supply	AVDD to AVSS	4.75	5	5.25	V
		AVSS to DGND	–2.6		0	
	Digital power supply	DVDD to DGND	2.7		5.25	V
<b>ANALOG INPUTS</b>						
$V_{(AINx)}$	Absolute input voltage	PGA mode	See 公式 5			V
		PGA bypassed	AVSS – 0.1		AVDD + 0.1	
$V_{IN}$	Differential input voltage	$V_{IN} = V_{AINp} - V_{AINn}$	$\pm V_{REF} / \text{Gain}$		See <sup>(1)</sup>	V
<b>VOLTAGE REFERENCE INPUTS</b>						
$V_{REF}$	Differential reference voltage	$V_{REF} = V_{(REFPx)} - V_{(REFNx)}$	0.9		AVDD – AVSS	V
$V_{(REFNx)}$	Negative reference voltage		AVSS – 0.05		$V_{(REFPx)} - 0.9$	V
$V_{(REFPx)}$	Positive reference voltage		$V_{(REFNx)} + 0.9$		AVDD + 0.05	V
<b>EXTERNAL CLOCK</b>						
$f_{CLK}$	Frequency	2.5 SPS to 25.6 kSPS	1	7.3728	8	MHz
		40 kSPS	1	10.24	10.75	
	Duty cycle		40%		60%	
<b>GENERAL-PURPOSE INPUTS/OUTPUTS (GPIOs)</b>						
	Input voltage		AVSS		AVDD	V
<b>DIGITAL INPUTS (Other Than GPIOs)</b>						
	Input voltage		DGND		DVDD	V
<b>TEMPERATURE</b>						
$T_A$	Operating ambient temperature		–45		125	°C

- (1) In PGA mode, the maximum differential input voltage is  $\pm(AVDD - AVSS - 0.6 \text{ V}) / \text{Gain}$ , when operating with  $V_{REF} \geq AVDD - AVSS - 0.6 \text{ V}$ .

### 7.4 Thermal Information

THERMAL METRIC <sup>(1)</sup>		ADS126x	UNIT
		RHB (VQFN)	
		32 PINS	
$R_{\theta JA}$	Junction-to-ambient thermal resistance	28.6	°C/W
$R_{\theta JC(top)}$	Junction-to-case (top) thermal resistance	17.0	°C/W
$R_{\theta JB}$	Junction-to-board thermal resistance	9.7	°C/W
$\Psi_{JT}$	Junction-to-top characterization parameter	0.2	°C/W
$\Psi_{JB}$	Junction-to-board characterization parameter	9.7	°C/W
$R_{\theta JC(bot)}$	Junction-to-case (bottom) thermal resistance	0.7	°C/W

- (1) For more information about traditional and new thermal metrics, see the [Semiconductor and IC Package Thermal Metrics application report](#).

## 7.5 Electrical Characteristics

minimum and maximum specifications apply from  $T_A = -40^\circ\text{C}$  to  $+125^\circ\text{C}$ ; typical specifications are at  $T_A = 25^\circ\text{C}$ ; all specifications are at  $AVDD = 5\text{ V}$ ,  $AVSS = 0\text{ V}$ ,  $DVDD = 3.3\text{ V}$ ,  $V_{REF} = 2.5\text{ V}$ ,  $f_{CLK} = 7.3728\text{ MHz}$ , PGA mode, gain = 1, and data rate = 20 SPS (unless otherwise noted)

PARAMETER		TEST CONDITIONS	MIN	TYP	MAX	UNIT
<b>ANALOG INPUTS</b>						
	Absolute input current	PGA mode, $V_{(AINx)} = 2.5\text{ V}$		4	6	nA
		PGA bypass		200		
	Absolute input current drift			0.01		nA/°C
	Differential input current	PGA mode, $V_{IN} = 19\text{ mV}$		$\pm 0.1$		nA
		PGA mode, $V_{IN} = 2.5\text{ V}$	-3	$\pm 1$	3	
		PGA mode, chop mode <sup>(1)</sup>		$\pm 5$		
		PGA bypass, $V_{IN} = 2.5\text{ V}$		$\pm 40$		
	Differential input current drift			0.05		nA/°C
	Differential input impedance	PGA mode		1		G $\Omega$
		PGA bypass		50		M $\Omega$
	Crosstalk			0.1		$\mu\text{V/V}$
<b>PGA</b>						
	Gain settings		1, 2, 4, 8, 16, 32, 64, 128			V/V
	Antialias filter frequency	$C_{CAPP}$ , $C_{APN} = 4.7\text{ nF}$		60		kHz
<b>PERFORMANCE</b>						
	Resolution	No missing codes	24			Bits
DR	Data rate		2.5		40000	SPS
	Noise performance			See 表 1		
INL	Integral nonlinearity	Gain = 1 to 16	-10	$\pm 2$	10	ppm <sub>FSR</sub>
		Gain = 32 to 128	-12	$\pm 3$	12	
		Gain = 1 to 32 (40 kSPS)	-15	$\pm 5$	15	
$V_{OS}$	Offset voltage	$T_A = 25^\circ\text{C}$	-175 / gain - 5	$\pm 50$ / gain	175 / gain + 5	$\mu\text{V}$
		$T_A = 25^\circ\text{C}$ , chop mode	-0.5 / gain - 0.05	$\pm 0.2$ / gain	0.5 / gain + 0.05	
		After calibration	On the level of noise			
	Offset voltage drift	Gain = 1 to 8		100 / gain	350 / gain	nV/°C
		Gain = 16 to 128		10	50	
		Chop mode, gain = 1 to 128		1	5	
	Offset voltage long-term drift	Gain = 1, 1000 hr		$\pm 0.1$		$\mu\text{V}$
GE	Gain error	$T_A = 25^\circ\text{C}$ , gain = 1 to 128	-0.5%	$\pm 0.05\%$	0.5%	
		After calibration	On the level of noise			
	Gain drift	Gain = 1 to 128		0.5	4	ppm/°C
NMRR	Normal-mode rejection ratio <sup>(2)</sup>			See 表 7		
CMRR	Common-mode rejection ratio <sup>(3)</sup>	Data rate = 20 SPS		130		dB
		Data rate = 400 SPS	105	115		
PSRR	Power-supply rejection ratio <sup>(4)</sup>	AVDD and AVSS	85	100		dB
		DVDD	100	120		
<b>INTERNAL OSCILLATOR</b>						
$f_{CLK}$	Frequency	2.5 SPS to 25.6 kSPS		7.3728		MHz
		40 kSPS		10.24		
	Accuracy		-2%	$\pm 0.5\%$	2%	

(1) Chop-mode input current scales with data rate.

(2) Normal-mode rejection ratio performance depends on the digital filter configuration.

(3) Common-mode rejection ratio is specified at 60 Hz.

(4) Power-supply rejection ratio specified at dc. PSRR (dB) = 20 Log ( $\Delta$  power supply voltage /  $\Delta$  offset voltage).

## Electrical Characteristics (continued)

minimum and maximum specifications apply from  $T_A = -40^{\circ}\text{C}$  to  $+125^{\circ}\text{C}$ ; typical specifications are at  $T_A = 25^{\circ}\text{C}$ ; all specifications are at  $AVDD = 5\text{ V}$ ,  $AVSS = 0\text{ V}$ ,  $DVDD = 3.3\text{ V}$ ,  $V_{REF} = 2.5\text{ V}$ ,  $f_{CLK} = 7.3728\text{ MHz}$ , PGA mode, gain = 1, and data rate = 20 SPS (unless otherwise noted)

PARAMETER		TEST CONDITIONS	MIN	TYP	MAX	UNIT
<b>VOLTAGE REFERENCE INPUTS</b>						
	Absolute input current			±250		nA
	Input current vs voltage			15		nA/V
	Input current drift			0.2		nA/°C
	Input impedance	Differential		30		MΩ
<b>INTERNAL VOLTAGE REFERENCE<sup>(5)</sup></b>						
	Voltage			2.5		V
	Initial error	$T_A = 25^{\circ}\text{C}$ , ADS1260B, ADS1261B		±0.1%	±0.2%	
		$T_A = 25^{\circ}\text{C}$ , ADS1261		±0.2%		
	Temperature drift	$T_A = 0^{\circ}\text{C}$ to $+85^{\circ}\text{C}$ , ADS1260B, ADS1261B		2	9	ppm/°C
		$T_A = -40^{\circ}\text{C}$ to $+125^{\circ}\text{C}$ , ADS1260B, ADS1261B		4	12	
		$T_A = -40^{\circ}\text{C}$ to $+125^{\circ}\text{C}$ , ADS1261		10	40	
	Long-term drift	1000 hr		±25		ppm
	Thermal hysteresis <sup>(6)</sup>	First temperature cycle		±70		ppm
		Second temperature cycle		±20		
	Output current		-10		10	mA
	Load regulation			50		μV/mA
	Start-up time	Settling time to ±0.001% of final value		100		ms
<b>EXCITATION CURRENT SOURCES (IDACS)</b>						
	Current settings			50, 100, 250, 500, 750, 1000, 1500, 2000, 2500, 3000		μA
	Compliance range		AVSS		AVDD - 1.1	V
	Accuracy		-4%	±0.7%	4%	
	Match error	Same current magnitudes	-1%	±0.1%	1%	
		Different current magnitudes		±1%		
	Temperature drift	Absolute		50		ppm/°C
		Match drift, $I_{DAC1} = I_{DAC2}$		5	25	
<b>LEVEL-SHIFT VOLTAGE (VBIAS)</b>						
	Voltage			(AVDD + AVSS) / 2		V
	Output impedance			100		Ω
<b>BURN-OUT CURRENT SOURCES</b>						
	Current settings	Sink and source		0.05, 0.2, 1, 10		μA
	Accuracy	0.05-μA range	0.025	0.05	0.075	μA
<b>TEMPERATURE SENSOR</b>						
	Sensor voltage	$T_A = 25^{\circ}\text{C}$		122.4		mV
	Temperature coefficient			420		μV/°C
<b>MONITORS</b>						
	PGA output	Low		AVSS + 0.2		V
		High		AVDD - 0.2		
	Reference voltage	Low		0.4	0.6	V

(5) Soldered to PCB using recommended PCB layout pattern and using reflow profile per JEDEC standard J-STD-020D.1

(6) Voltage reference hysteresis measured by operating the device at  $25^{\circ}\text{C}$  cycling the device to  $0^{\circ}\text{C}$  and  $105^{\circ}\text{C}$  and returning the device to  $25^{\circ}\text{C}$ .

## Electrical Characteristics (continued)

minimum and maximum specifications apply from  $T_A = -40^{\circ}\text{C}$  to  $+125^{\circ}\text{C}$ ; typical specifications are at  $T_A = 25^{\circ}\text{C}$ ; all specifications are at  $AVDD = 5\text{ V}$ ,  $AVSS = 0\text{ V}$ ,  $DVDD = 3.3\text{ V}$ ,  $V_{REF} = 2.5\text{ V}$ ,  $f_{CLK} = 7.3728\text{ MHz}$ , PGA mode, gain = 1, and data rate = 20 SPS (unless otherwise noted)

PARAMETER		TEST CONDITIONS	MIN	TYP	MAX	UNIT
<b>GENERAL-PURPOSE INPUTS/OUTPUTS (GPIOs)<sup>(7)</sup></b>						
$V_{OL}$	Low-level output voltage	$I_{OL} = -1\text{ mA}$			$0.2 \cdot AVDD$	V
$V_{OH}$	High-level output voltage	$I_{OH} = 1\text{ mA}$	$0.8 \cdot AVDD$			V
$V_{IL}$	Low-level input voltage				$0.3 \cdot AVDD$	V
$V_{IH}$	High-level input voltage		$0.7 \cdot AVDD$			V
	Input hysteresis			0.5		V
<b>DIGITAL INPUTS/OUTPUTS (Other Than GPIOs)</b>						
$V_{OL}$	Low-level output voltage	$I_{OL} = -1\text{ mA}$			$0.2 \cdot DVDD$	V
		$I_{OL} = -8\text{ mA}$		$0.2 \cdot DVDD$		
$V_{OH}$	High-level output voltage	$I_{OH} = 1\text{ mA}$	$0.8 \cdot DVDD$			V
		$I_{OH} = 8\text{ mA}$		$0.75 \cdot DVDD$		
$V_{IL}$	Low-level input voltage				$0.3 \cdot DVDD$	V
$V_{IH}$	High-level input voltage		$0.7 \cdot DVDD$			V
	Input hysteresis			0.1		V
	Input leakage	$V_{IH}$ or $V_{IL}$	-10		10	$\mu\text{A}$
<b>POWER SUPPLY</b>						
$I_{AVDD}, I_{AVSS}$	Analog supply current	PGA bypass		2.7	4.5	mA
		PGA mode, gain = 1 to 32		3.8	6	
		PGA mode, gain = 64 or 128		4.3	6.5	
		Power-down mode		2	8	$\mu\text{A}$
$I_{AVDD}, I_{AVSS}$	Analog supply current (by function)	Voltage reference		0.2		mA
		40-kSPS mode		0.5		
		Current sources		As programmed		
$I_{DVDD}$	Digital supply current	20 SPS		0.4	0.65	mA
		40 kSPS		0.6	0.85	
		Power-down mode <sup>(8)</sup>		30	50	$\mu\text{A}$
$P_D$	Power dissipation	PGA mode		20	32	mW
		Power-down mode		0.1	0.2	

(7) GPIO voltage with respect to AVSS.

(8) CLKIN input stopped.

## 7.6 Timing Requirements

over operating ambient temperature range, DVDD = 2.7 V to 5.25 V, and DOUT/ $\overline{\text{DRDY}}$  load: 20 pF || 100 k $\Omega$  to DGND (unless otherwise noted); see [Figure 8](#)

		MIN	MAX	UNIT
<b>SERIAL INTERFACE</b>				
$t_{d(\text{CSSC})}$	Delay time, first SCLK rising edge after $\overline{\text{CS}}$ falling edge <sup>(1)</sup>	50		ns
$t_{su(\text{DI})}$	Setup time, DIN valid before SCLK falling edge	25		ns
$t_{h(\text{DI})}$	Hold time, DIN valid after SCLK falling edge	25		ns
$t_{c(\text{SC})}$	SCLK period <sup>(2)</sup>	97	10 <sup>6</sup>	ns
$t_w(\text{SCH}),$ $t_w(\text{SCL})$	Pulse duration, SCLK high or low	40		ns
$t_{d(\text{SCCS})}$	Delay time, last SCLK falling edge before $\overline{\text{CS}}$ rising edge	50		ns
$t_w(\text{CSH})$	Pulse duration, $\overline{\text{CS}}$ high to reset interface	25		ns
$t_{d(\text{SCIR})}$	Delay time, SCLK high or low to force interface auto-reset		65540	1/ $f_{\text{CLK}}$
<b>RESET</b>				
$t_w(\text{RSTL})$	Pulse duration, $\overline{\text{RESET}}$ low	4		1/ $f_{\text{CLK}}$
<b>CONVERSION CONTROL</b>				
$t_w(\text{STH})$	Pulse duration, START high	4		1/ $f_{\text{CLK}}$
$t_w(\text{STL})$	Pulse duration, START low	4		1/ $f_{\text{CLK}}$
$t_{su(\text{DRST})}$	Setup time, START low or STOP command after $\overline{\text{DRDY}}$ low to stop next conversion (continuous mode)		100	1/ $f_{\text{CLK}}$
$t_{h(\text{DRSP})}$	Hold time, START low or STOP command after $\overline{\text{DRDY}}$ low to continue next conversion (continuous mode)	150		1/ $f_{\text{CLK}}$

(1)  $\overline{\text{CS}}$  can be tied low.

(2) Serial interface time-out mode: minimum SCLK frequency = 1 kHz. Otherwise, no minimum SCLK frequency.

### 7.7 Switching Characteristics

over operating ambient temperature range, DVDD = 2.7 V to 5.25 V, and DOUT/ $\overline{\text{DRDY}}$  load: 20 pF || 100 k $\Omega$  to DGND (unless otherwise noted); see [图 8](#)

PARAMETER		MIN	TYP	MAX	UNIT
<b>SERIAL INTERFACE</b>					
$t_{w(\text{DRH})}$	Pulse duration, $\overline{\text{DRDY}}$ high	16			$1/f_{\text{CLK}}$
$t_{p(\text{CSDO})}$	Propagation delay time, $\overline{\text{CS}}$ falling edge to DOUT/ $\overline{\text{DRDY}}$ driven	0		50	ns
$t_{p(\text{SCDO1})}$	Propagation delay time, SCLK rising edge to valid DOUT/ $\overline{\text{DRDY}}$			40	ns
$t_{h(\text{SCDO1})}$	Hold time, SCLK rising edge to invalid data on DOUT/ $\overline{\text{DRDY}}$	0			ns
$t_{h(\text{SCDO2})}$	Hold time, last SCLK falling edge of operation to invalid data on DOUT/ $\overline{\text{DRDY}}$	15			ns
$t_{p(\text{SCDO2})}$	Propagation delay time, last SCLK falling edge to valid data ready function on DOUT/ $\overline{\text{DRDY}}$			110	ns
$t_{p(\text{CSDOZ})}$	Propagation delay time, $\overline{\text{CS}}$ rising edge to DOUT/ $\overline{\text{DRDY}}$ high impedance			50	ns
<b>RESET</b>					
$t_{p(\text{RSCN})}$	Propagation delay time, $\overline{\text{RESET}}$ rising edge or RESET command to start of conversion	512			$1/f_{\text{CLK}}$
$t_{p(\text{PRCM})}$	Propagation delay time, power-on threshold voltage to ADC communication		$2^{16}$		$1/f_{\text{CLK}}$
$t_{p(\text{CMCN})}$	Propagation delay time, ADC communication to conversion start	512			$1/f_{\text{CLK}}$
<b>AC EXCITATION</b>					
$t_{d(\text{ACX})}$	Delay time, phase-to-phase blanking period		8		$1/f_{\text{CLK}}$
$t_{c(\text{ACX})}$	ACX period	2			$t_{\text{STDR}}$
<b>CONVERSION CONTROL</b>					
$t_{p(\text{STDR})}$	Propagation delay time, START high or START command to $\overline{\text{DRDY}}$ high			2	$1/f_{\text{CLK}}$



图 1. Serial Interface Timing Requirements



<sup>(1)</sup> Before the first SCLK rising edge and after the last SCLK falling edge of a command, the function of DOUT/DRDY is data ready.

图 2. Serial Interface Switching Characteristics

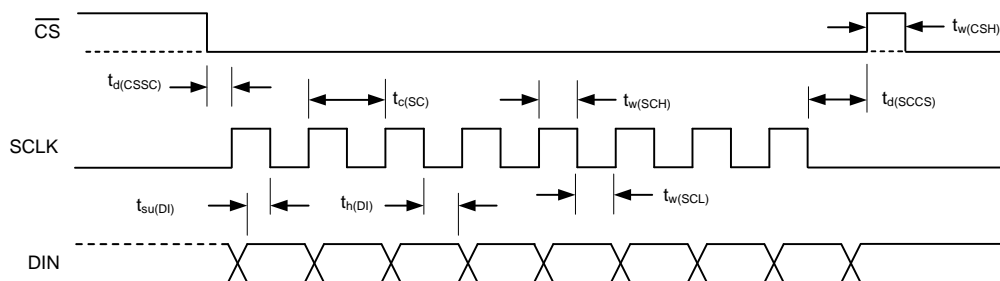
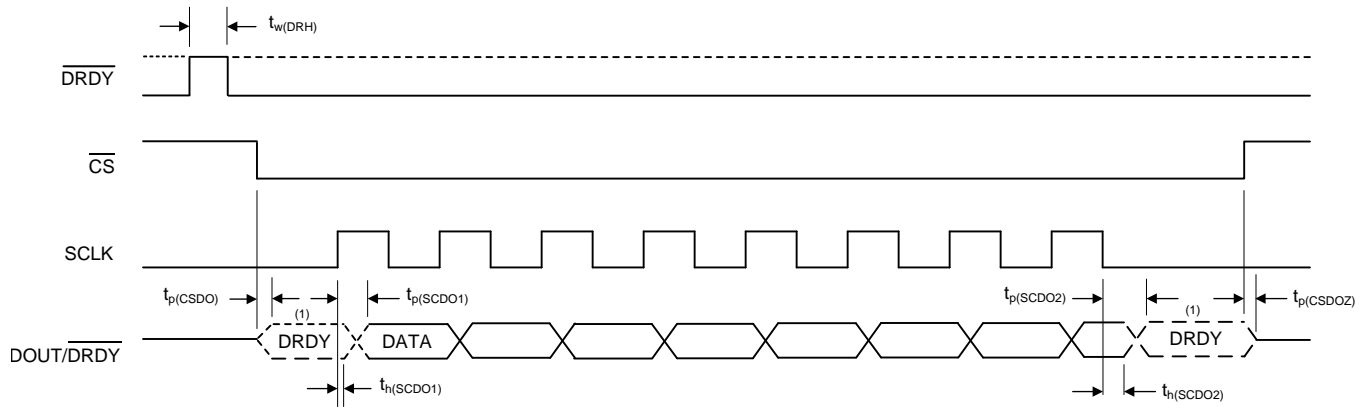

图 3. Serial Interface Auto-Reset Characteristics



图 4. Conversion Control Timing Requirements

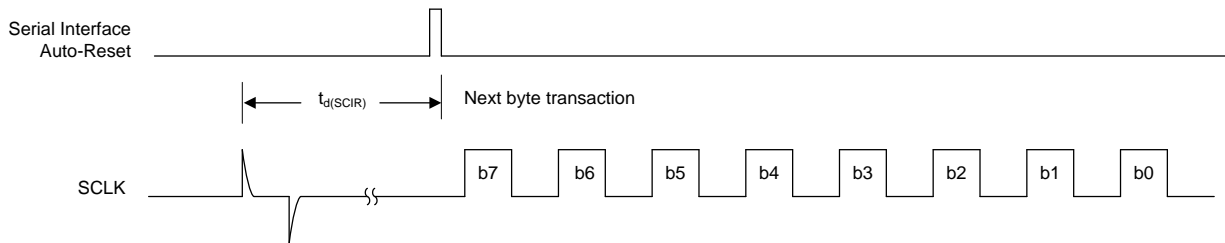

图 5. Power-Up Characteristics

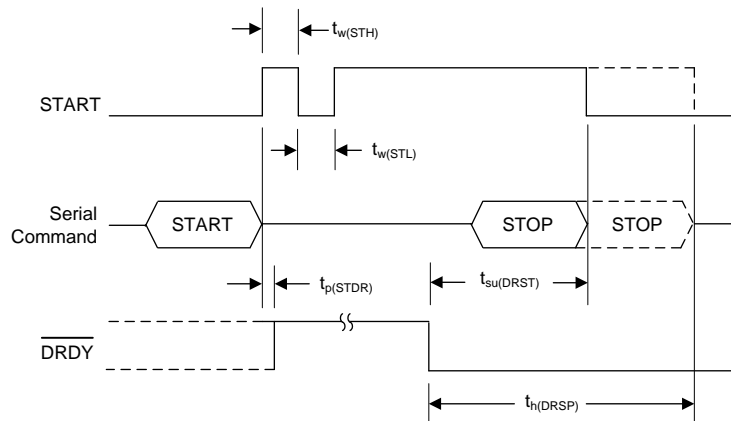

图 6. RESET pin and RESET Command Timing Requirements

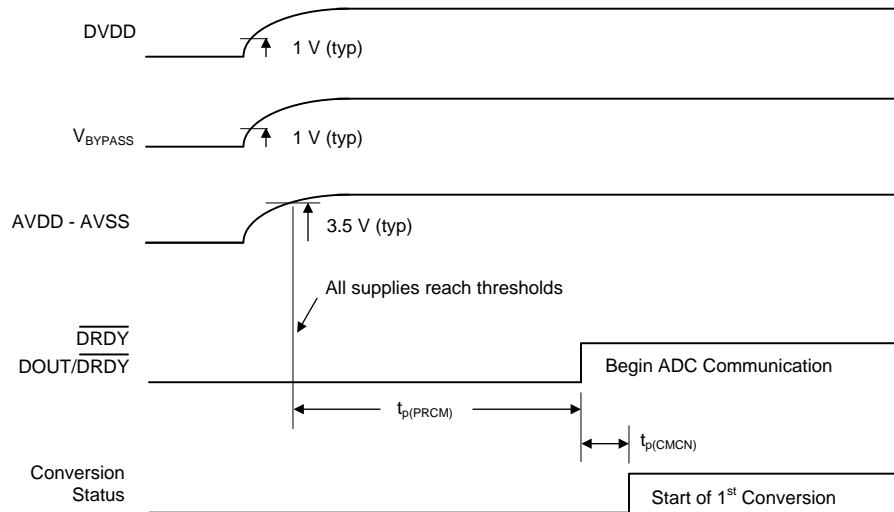

图 7. AC-Excitation Timing Characteristics

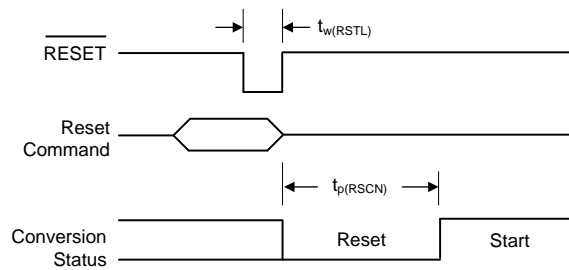

图 8. Timing Voltage-Level Reference

### 7.8 Typical Characteristics

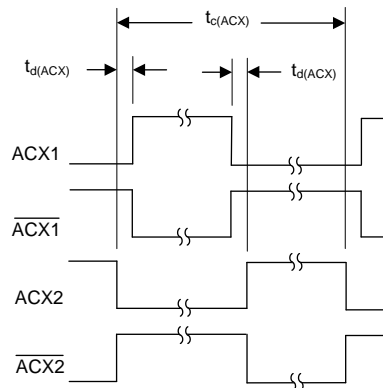
at  $T_A = 25^\circ\text{C}$ ,  $AVDD = 5\text{ V}$ ,  $AVSS = 0\text{ V}$ ,  $DVDD = 3.3\text{ V}$ ,  $V_{REF} = 2.5\text{ V}$ , data rate = 20 SPS,  $f_{CLK} = 7.3728\text{ MHz}$  ( $f_{CLK} = 10.24\text{ MHz}$  for data rate = 40 kSPS), and gain = 1 (unless otherwise noted)

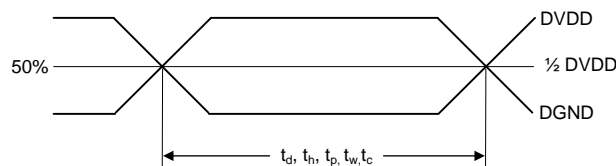
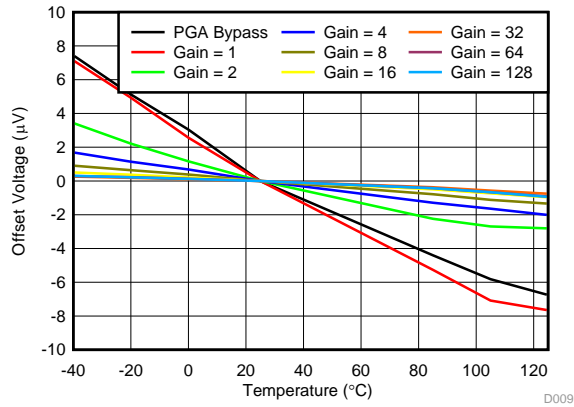

After calibration, shorted input  
**图 9. Offset Voltage vs Temperature**

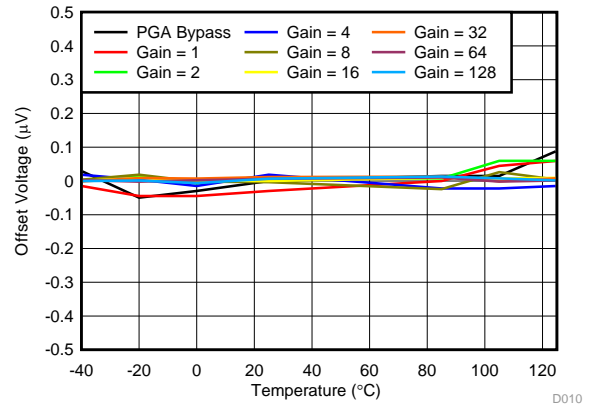

Chop mode, after calibration, shorted input  
**图 10. Offset Voltage vs Temperature**

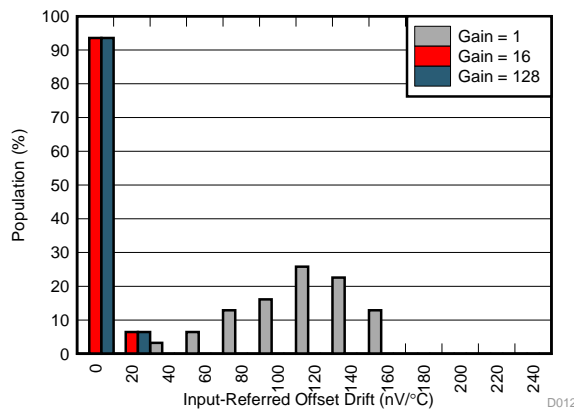

Shorted input, 30 units  
**图 11. Offset Voltage Drift Distribution**

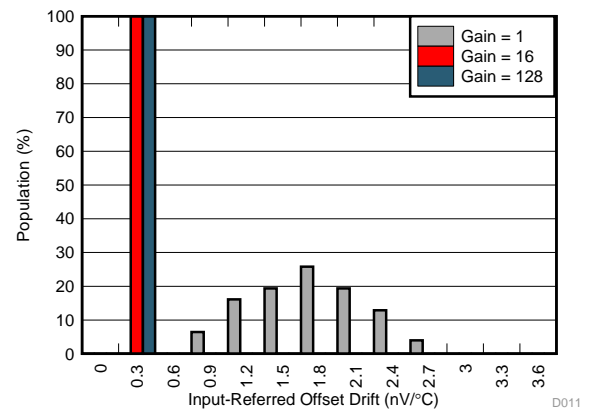

Chop mode, shorted input, 30 units  
**图 12. Offset Voltage Drift Distribution**

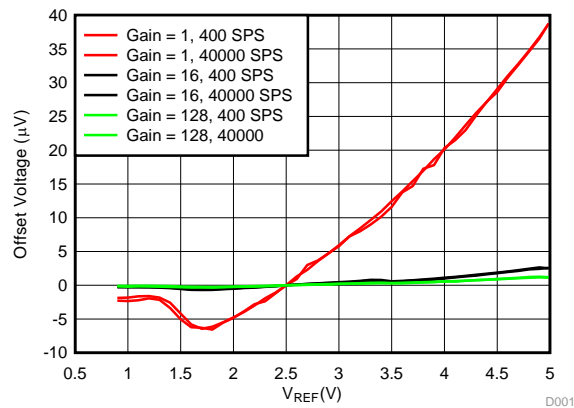

After calibration  
**图 13. Offset Voltage vs Reference Voltage**

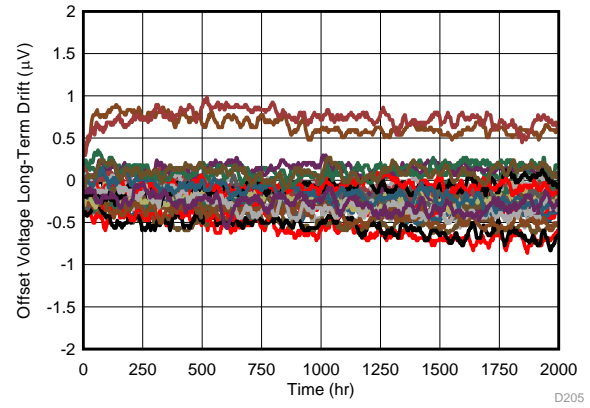

After calibration, gain = 1  
**图 14. Offset Voltage Long-Term Drift**

Typical Characteristics (接下页)

at  $T_A = 25^\circ\text{C}$ ,  $AVDD = 5\text{ V}$ ,  $AVSS = 0\text{ V}$ ,  $DVDD = 3.3\text{ V}$ ,  $V_{REF} = 2.5\text{ V}$ , data rate = 20 SPS,  $f_{CLK} = 7.3728\text{ MHz}$  ( $f_{CLK} = 10.24\text{ MHz}$  for data rate = 40 kSPS), and gain = 1 (unless otherwise noted)

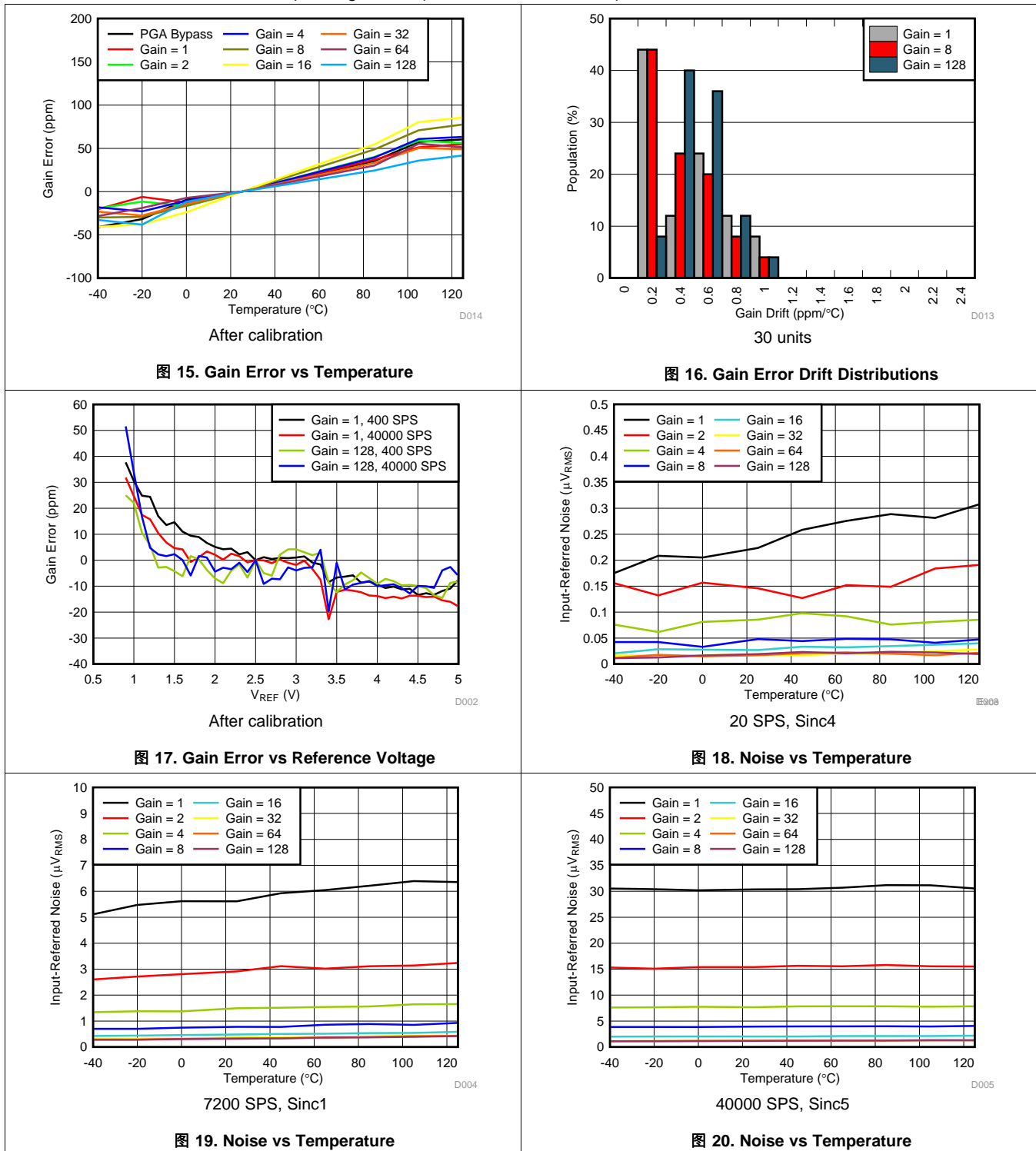

Typical Characteristics (接下页)

at  $T_A = 25^\circ\text{C}$ ,  $AV_{DD} = 5\text{ V}$ ,  $AV_{SS} = 0\text{ V}$ ,  $DV_{DD} = 3.3\text{ V}$ ,  $V_{REF} = 2.5\text{ V}$ , data rate = 20 SPS,  $f_{CLK} = 7.3728\text{ MHz}$  ( $f_{CLK} = 10.24\text{ MHz}$  for data rate = 40 kSPS), and gain = 1 (unless otherwise noted)

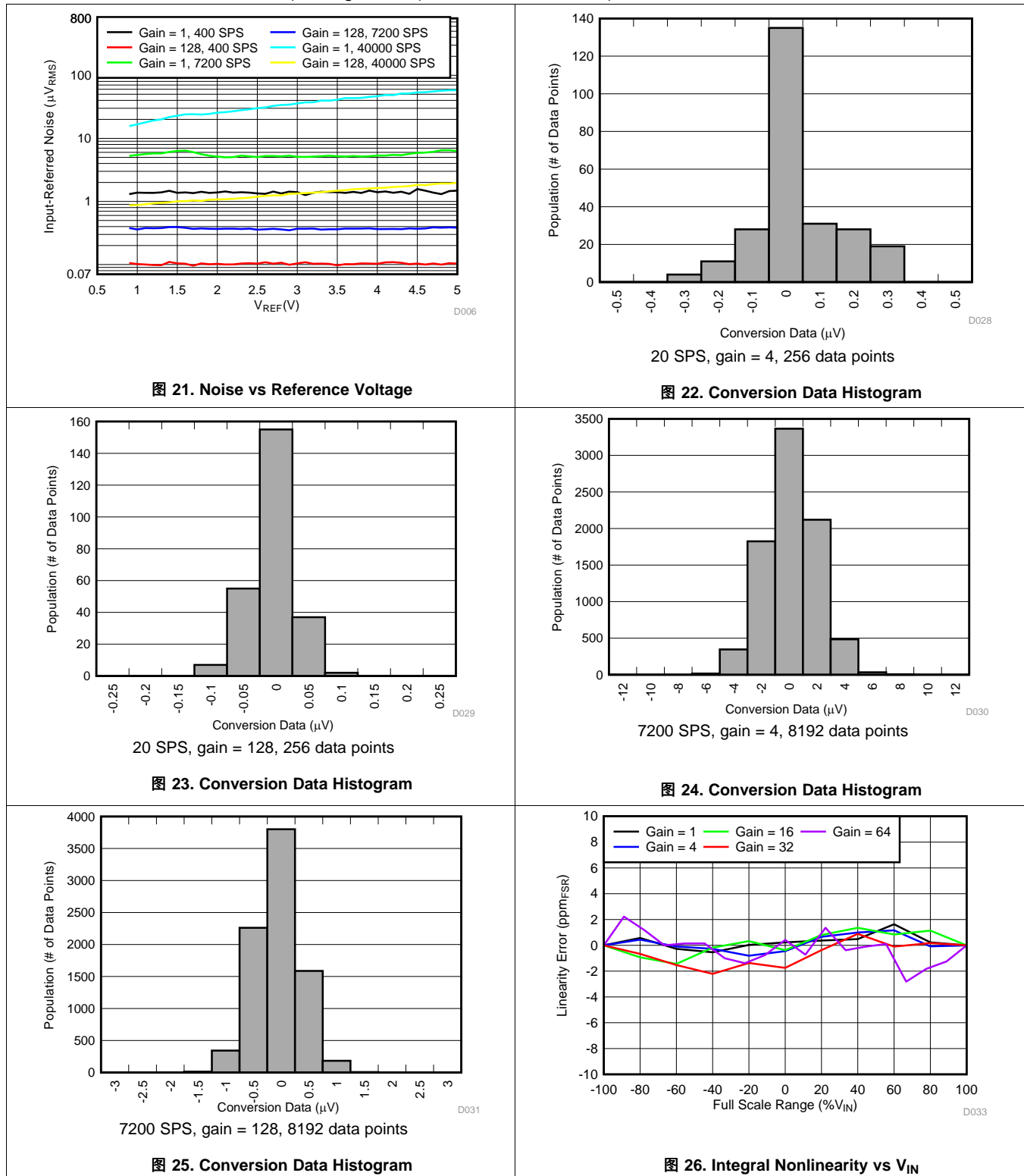

Typical Characteristics (接下页)

at  $T_A = 25^\circ\text{C}$ ,  $AVDD = 5\text{ V}$ ,  $AVSS = 0\text{ V}$ ,  $DVDD = 3.3\text{ V}$ ,  $V_{REF} = 2.5\text{ V}$ , data rate = 20 SPS,  $f_{CLK} = 7.3728\text{ MHz}$  ( $f_{CLK} = 10.24\text{ MHz}$  for data rate = 40 kSPS), and gain = 1 (unless otherwise noted)

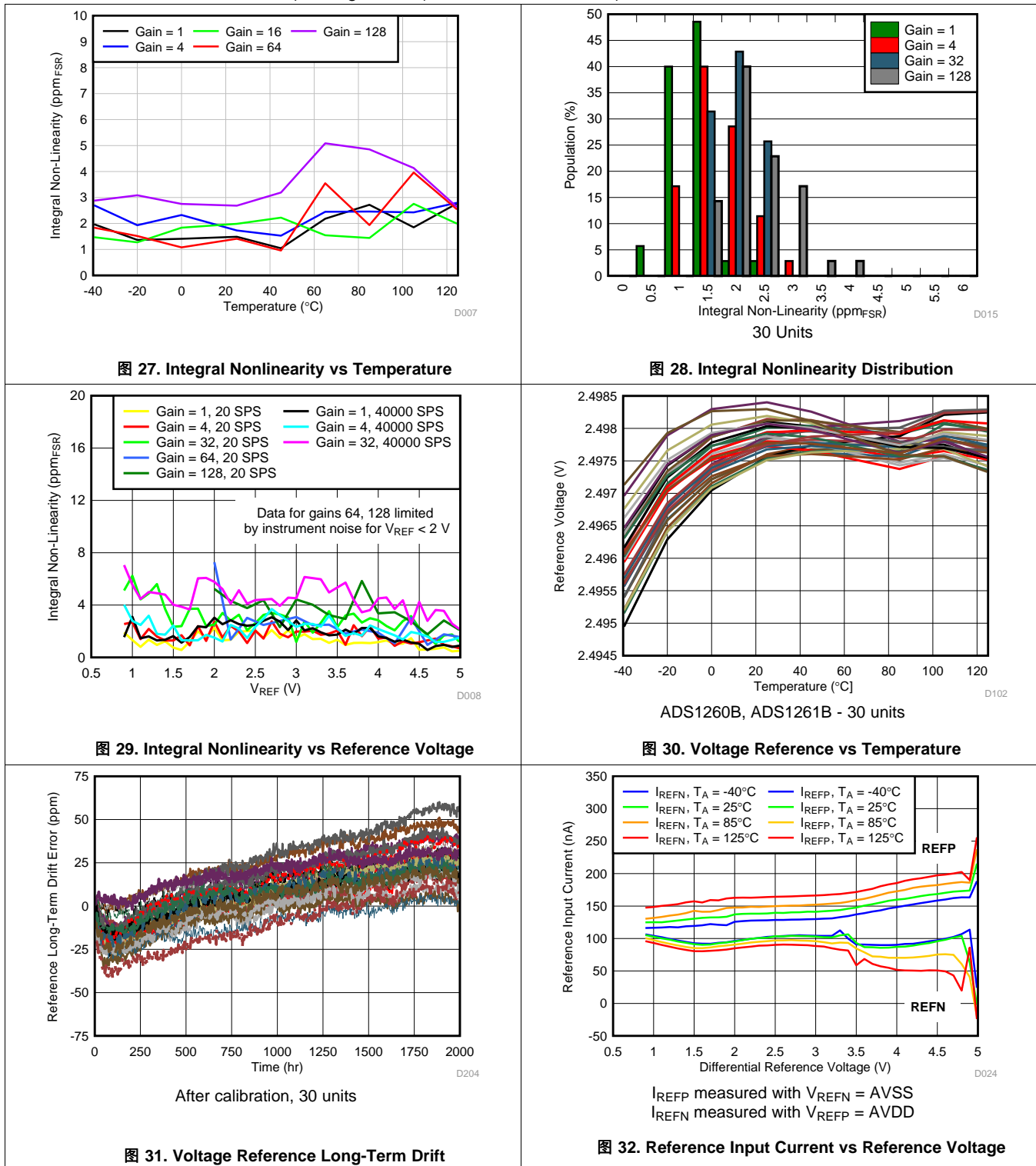

Typical Characteristics (接下页)

at  $T_A = 25^\circ\text{C}$ ,  $AVDD = 5\text{ V}$ ,  $AVSS = 0\text{ V}$ ,  $DVDD = 3.3\text{ V}$ ,  $V_{REF} = 2.5\text{ V}$ , data rate = 20 SPS,  $f_{CLK} = 7.3728\text{ MHz}$  ( $f_{CLK} = 10.24\text{ MHz}$  for data rate = 40 kSPS), and gain = 1 (unless otherwise noted)



图 33. Temperature Sensor Voltage Histogram



图 34. Internal Oscillator vs Temperature

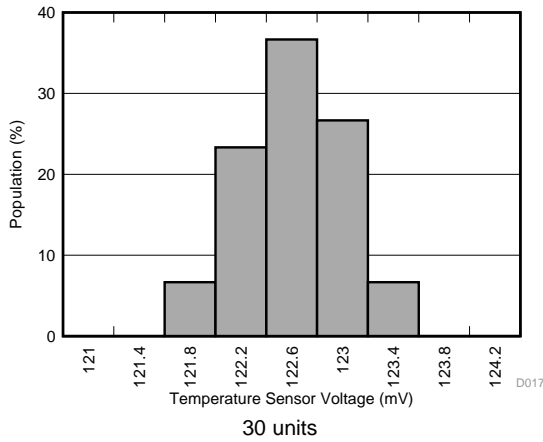

图 35. Operating Current vs Temperature

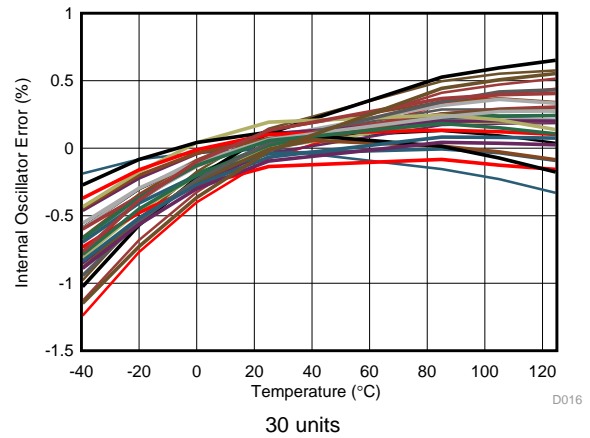

图 36. PGA High Monitor Threshold

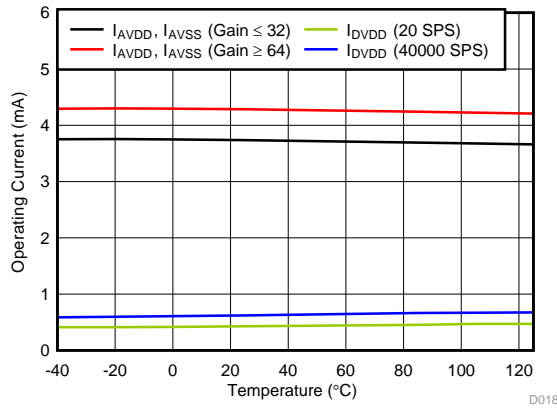

图 37. PGA Low Monitor Threshold

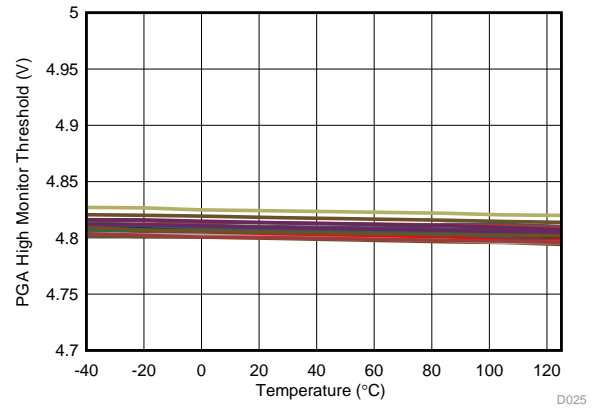

图 38. Reference Voltage Low Alarm Threshold

Typical Characteristics (接下页)

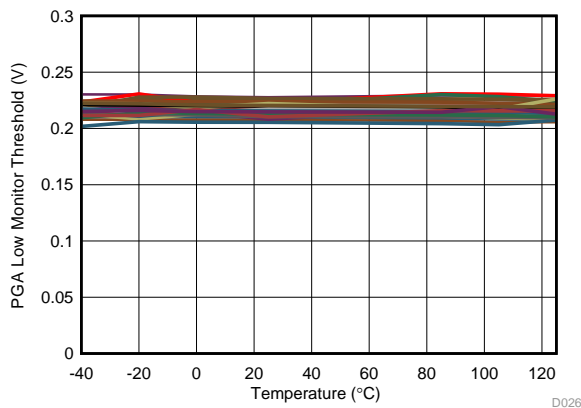
at  $T_A = 25^\circ\text{C}$ ,  $AVDD = 5\text{ V}$ ,  $AVSS = 0\text{ V}$ ,  $DVDD = 3.3\text{ V}$ ,  $V_{REF} = 2.5\text{ V}$ , data rate = 20 SPS,  $f_{CLK} = 7.3728\text{ MHz}$  ( $f_{CLK} = 10.24\text{ MHz}$  for data rate = 40 kSPS), and gain = 1 (unless otherwise noted)

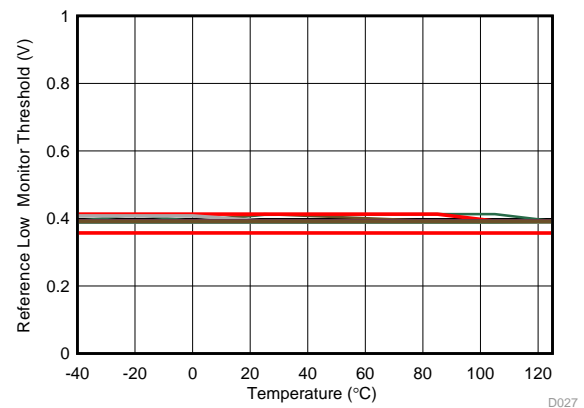
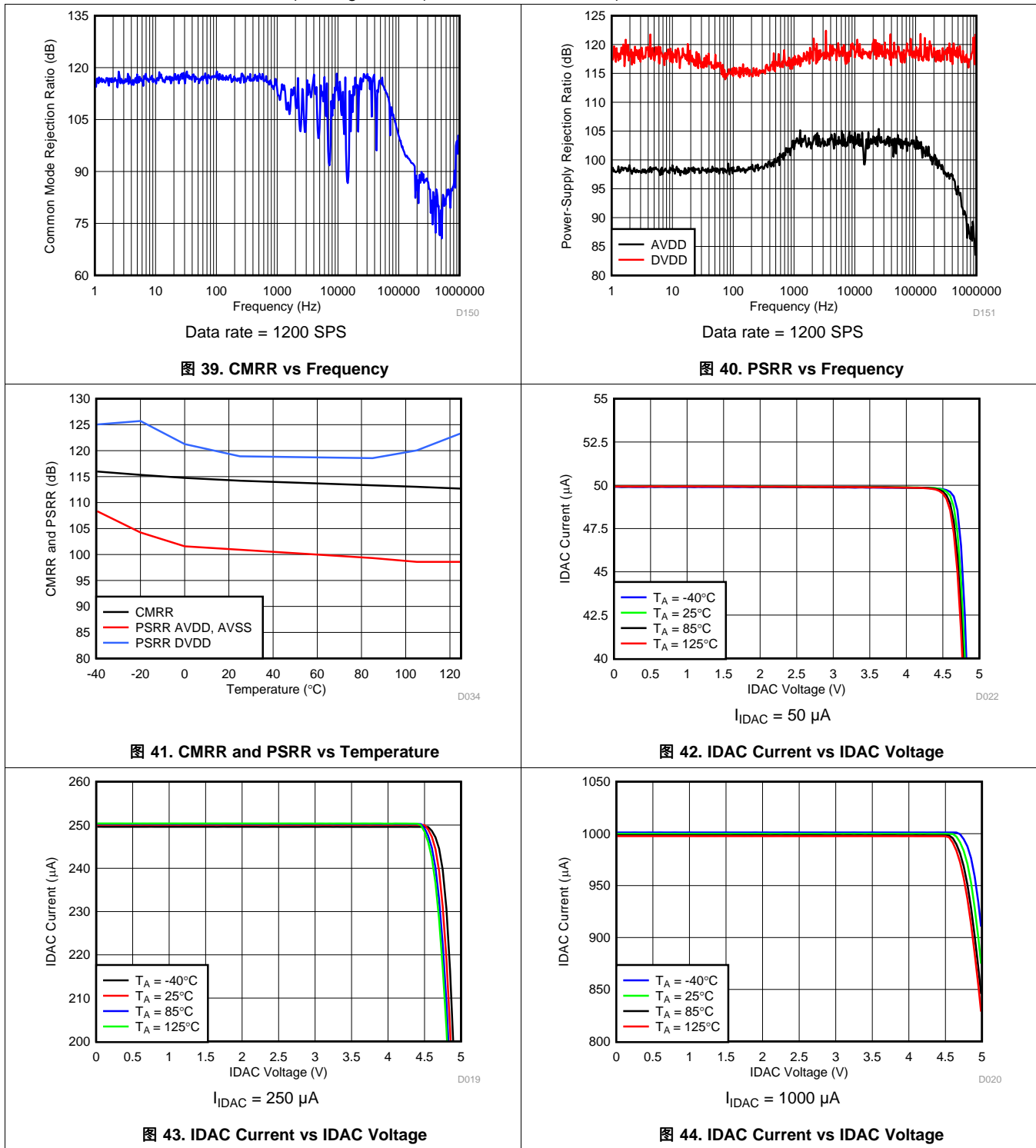

Typical Characteristics (接下页)

at  $T_A = 25^\circ\text{C}$ ,  $AVDD = 5\text{ V}$ ,  $AVSS = 0\text{ V}$ ,  $DVDD = 3.3\text{ V}$ ,  $V_{REF} = 2.5\text{ V}$ , data rate = 20 SPS,  $f_{CLK} = 7.3728\text{ MHz}$  ( $f_{CLK} = 10.24\text{ MHz}$  for data rate = 40 kSPS), and gain = 1 (unless otherwise noted)



图 45. IDAC Current vs IDAC Voltage



图 46. IDAC Current Match vs IDAC Voltage

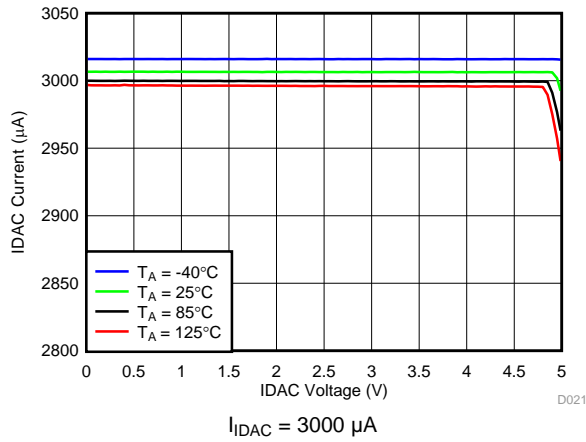

图 47. IDAC Current Match vs IDAC Voltage

## 8 Parameter Measurement Information

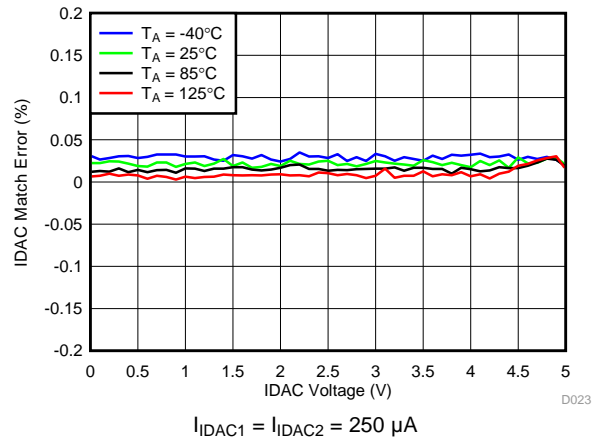
### 8.1 Noise Performance

The ADS126x noise performance depends on the ADC configuration: data rate, PGA gain, digital filter configuration, and chop mode. The combination of the parameters affect noise performance. Two significant factors affecting noise performance are data rate and PGA gain. Since the profile of noise is predominantly white (flat vs frequency), decreasing the data rate proportionally decreases bandwidth and therefore, total noise. Since the noise of the PGA is lower than that of the modulator of the ADC, increasing the gain reduces noise when treated as an input-referred quantity. Noise performance also depends on the digital filter and chop mode. As the order of the digital filter increases, the noise bandwidth correspondingly decreases resulting in lower noise. Further, as a result of two-point data averaging in chop mode, noise performance improves by  $\sqrt{2}$  compared to normal operation.

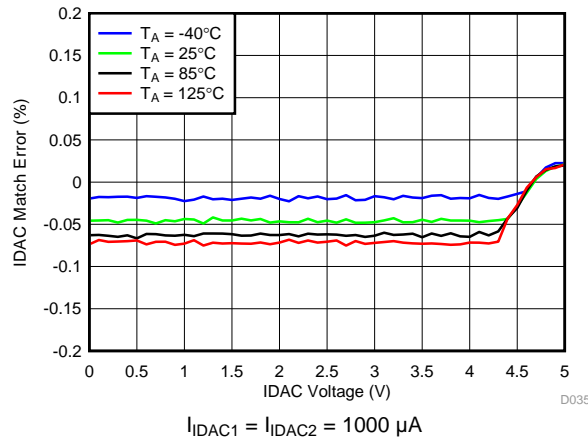
表 1 shows noise performance in units of  $\mu V_{RMS}$  (RMS = root mean square) under the conditions listed. The values in parenthesis are peak-to-peak values. 表 2 shows the noise performance in effective resolution (bits) under the specified conditions. The values shown in parenthesis are the noise-free resolution. Noise-free resolution is the resolution of the ADC with no code flicker. The noise-free resolution data are calculated based on the peak-to-peak noise measurements.

The effective resolution data listed in the tables are calculated using 公式 1:

$$\text{Effective Resolution or Noise-Free Resolution} = \ln(\text{FSR} / e_n) / \ln(2)$$

where

- FSR = full scale range =  $2 \cdot V_{REF} / \text{Gain}$  (See [Recommended Operating Conditions](#) for FSR)
- $e_n$  = Input referred voltage noise (RMS value to calculate effective resolution, p-p value to calculate noise-free resolution) (1)

The data shown in the noise performance table represent typical ADC performance at  $T_A = 25^\circ\text{C}$ . The noise-performance data are the standard deviation and peak-to-peak computations of the ADC data. The noise data are acquired with inputs shorted, based on consecutive ADC readings for a period of ten seconds or 8192 data points, whichever occurs first. Because of the statistical nature of noise, repeated noise measurements may yield higher or lower noise performance results.

As a result of the increased full-scale input range provided by 5-V reference operation, effective resolution and noise-free resolution performance are typically optimized using a 5-V reference. The effective resolution and noise-free resolution performance data shown in 表 2 are with external 5-V reference operation.

表 1. Noise in  $\mu V_{RMS}$  ( $\mu V_{PP}$ ) at  $T_A = 25^\circ\text{C}$  and Internal 2.5-V Reference

DATA RATE (SPS)	FILTER	GAIN							
		1	2	4	8	16	32	64	128
2.5	FIR	0.18 (0.6)	0.078 (0.28)	0.046 (0.16)	0.025 (0.096)	0.014 (0.053)	0.012 (0.045)	0.01 (0.042)	0.01 (0.04)
2.5	Sinc1	0.15 (0.47)	0.071 (0.28)	0.038 (0.14)	0.019 (0.075)	0.012 (0.051)	0.01 (0.039)	0.009 (0.037)	0.009 (0.037)
2.5	Sinc2	0.14 (0.38)	0.065 (0.23)	0.032 (0.096)	0.018 (0.059)	0.011 (0.037)	0.007 (0.028)	0.007 (0.028)	0.008 (0.033)
2.5	Sinc3	0.12 (0.38)	0.062 (0.17)	0.028 (0.064)	0.016 (0.053)	0.01 (0.035)	0.008 (0.027)	0.007 (0.026)	0.006 (0.023)
2.5	Sinc4	0.1 (0.26)	0.059 (0.17)	0.032 (0.085)	0.016 (0.059)	0.010 (0.035)	0.008 (0.027)	0.006 (0.025)	0.006 (0.024)
5	FIR	0.22 (0.89)	0.11 (0.4)	0.058 (0.24)	0.032 (0.13)	0.021 (0.085)	0.016 (0.065)	0.014 (0.061)	0.015 (0.066)
5	Sinc1	0.18 (0.6)	0.093 (0.36)	0.047 (0.17)	0.025 (0.11)	0.017 (0.069)	0.014 (0.061)	0.012 (0.054)	0.014 (0.063)
5	Sinc2	0.16 (0.64)	0.084 (0.32)	0.043 (0.16)	0.023 (0.085)	0.015 (0.064)	0.011 (0.047)	0.010 (0.046)	0.011 (0.049)
5	Sinc3	0.13 (0.51)	0.088 (0.32)	0.036 (0.15)	0.024 (0.091)	0.014 (0.053)	0.01 (0.043)	0.009 (0.045)	0.009 (0.042)
5	Sinc4	0.13 (0.51)	0.077 (0.28)	0.034 (0.12)	0.021 (0.075)	0.013 (0.053)	0.010 (0.044)	0.008 (0.038)	0.009 (0.038)
10	FIR	0.27 (1.4)	0.14 (0.72)	0.076 (0.4)	0.042 (0.21)	0.029 (0.15)	0.023 (0.12)	0.023 (0.11)	0.022 (0.11)
10	Sinc1	0.23 (1.1)	0.13 (0.57)	0.064 (0.3)	0.036 (0.19)	0.024 (0.13)	0.02 (0.1)	0.018 (0.083)	0.018 (0.089)
10	Sinc2	0.2 (0.89)	0.11 (0.51)	0.054 (0.24)	0.03 (0.14)	0.019 (0.093)	0.015 (0.075)	0.015 (0.079)	0.016 (0.077)
10	Sinc3	0.18 (0.81)	0.097 (0.38)	0.05 (0.22)	0.028 (0.14)	0.019 (0.088)	0.015 (0.063)	0.013 (0.067)	0.013 (0.065)
10	Sinc4	0.17 (0.68)	0.099 (0.45)	0.049 (0.24)	0.024 (0.12)	0.018 (0.085)	0.013 (0.063)	0.012 (0.061)	0.012 (0.062)
16.6	Sinc1	0.3 (1.4)	0.16 (0.81)	0.082 (0.43)	0.048 (0.25)	0.031 (0.17)	0.025 (0.15)	0.024 (0.12)	0.024 (0.14)

**Noise Performance (接下页)**
**表 1. Noise in  $\mu\text{V}_{\text{RMS}}$  ( $\mu\text{V}_{\text{PP}}$ ) at  $T_A = 25^\circ\text{C}$  and Internal 2.5-V Reference (接下页)**

DATA RATE (SPS)	FILTER	GAIN							
		1	2	4	8	16	32	64	128
16.6	Sinc2	0.24 (1.2)	0.13 (0.64)	0.067 (0.34)	0.038 (0.2)	0.026 (0.14)	0.021 (0.11)	0.019 (0.099)	0.019 (0.098)
16.6	Sinc3	0.22 (0.98)	0.12 (0.64)	0.065 (0.3)	0.036 (0.18)	0.024 (0.12)	0.019 (0.095)	0.017 (0.092)	0.018 (0.093)
16.6	Sinc4	0.21 (1.1)	0.12 (0.53)	0.06 (0.29)	0.035 (0.18)	0.022 (0.11)	0.017 (0.084)	0.016 (0.085)	0.016 (0.086)
20	FIR	0.37 (2)	0.2 (1.1)	0.1 (0.56)	0.059 (0.34)	0.041 (0.22)	0.034 (0.18)	0.029 (0.17)	0.03 (0.15)
20	Sinc1	0.32 (1.8)	0.18 (0.92)	0.091 (0.48)	0.051 (0.26)	0.034 (0.2)	0.028 (0.15)	0.025 (0.14)	0.025 (0.14)
20	Sinc2	0.27 (1.4)	0.15 (0.77)	0.073 (0.35)	0.042 (0.22)	0.027 (0.14)	0.022 (0.13)	0.021 (0.11)	0.02 (0.11)
20	Sinc3	0.24 (1.2)	0.13 (0.64)	0.069 (0.35)	0.039 (0.21)	0.026 (0.14)	0.02 (0.11)	0.018 (0.099)	0.018 (0.1)
20	Sinc4	0.23 (1.1)	0.13 (0.66)	0.066 (0.33)	0.037 (0.19)	0.024 (0.12)	0.018 (0.095)	0.017 (0.095)	0.017 (0.099)
50	Sinc1	0.49 (2.9)	0.27 (1.6)	0.14 (0.83)	0.08 (0.5)	0.053 (0.31)	0.043 (0.25)	0.039 (0.23)	0.038 (0.23)
50	Sinc2	0.4 (2.3)	0.22 (1.3)	0.11 (0.69)	0.064 (0.38)	0.043 (0.27)	0.035 (0.22)	0.033 (0.2)	0.032 (0.2)
50	Sinc3	0.37 (2.2)	0.2 (1.2)	0.11 (0.64)	0.058 (0.35)	0.04 (0.25)	0.033 (0.19)	0.029 (0.18)	0.03 (0.18)
50	Sinc4	0.34 (2)	0.19 (1.1)	0.098 (0.61)	0.056 (0.32)	0.036 (0.23)	0.03 (0.17)	0.028 (0.17)	0.028 (0.17)
60	Sinc1	0.55 (3.3)	0.28 (1.9)	0.15 (0.88)	0.087 (0.53)	0.058 (0.34)	0.047 (0.28)	0.044 (0.29)	0.042 (0.26)
60	Sinc2	0.45 (2.7)	0.24 (1.4)	0.12 (0.71)	0.07 (0.45)	0.048 (0.32)	0.039 (0.25)	0.036 (0.21)	0.035 (0.21)
60	Sinc3	0.41 (2.7)	0.21 (1.3)	0.11 (0.68)	0.065 (0.4)	0.044 (0.25)	0.036 (0.23)	0.032 (0.19)	0.031 (0.19)
60	Sinc4	0.37 (2)	0.2 (1.1)	0.11 (0.6)	0.059 (0.36)	0.041 (0.25)	0.033 (0.21)	0.03 (0.18)	0.03 (0.17)
100	Sinc1	0.69 (4.5)	0.37 (2.4)	0.19 (1.3)	0.11 (0.73)	0.075 (0.5)	0.06 (0.39)	0.056 (0.37)	0.056 (0.38)
100	Sinc2	0.56 (3.5)	0.3 (1.9)	0.16 (0.97)	0.09 (0.55)	0.062 (0.39)	0.051 (0.32)	0.046 (0.31)	0.045 (0.29)
100	Sinc3	0.51 (3.4)	0.27 (1.8)	0.14 (0.9)	0.083 (0.51)	0.056 (0.36)	0.045 (0.3)	0.041 (0.27)	0.041 (0.25)
100	Sinc4	0.48 (3.3)	0.26 (1.6)	0.14 (0.87)	0.078 (0.48)	0.053 (0.34)	0.043 (0.27)	0.039 (0.24)	0.039 (0.26)
400	Sinc1	1.4 (9.6)	0.72 (5.4)	0.38 (2.7)	0.22 (1.6)	0.15 (1.1)	0.12 (0.85)	0.11 (0.85)	0.11 (0.79)
400	Sinc2	1.1 (8.2)	0.58 (4.2)	0.31 (2.3)	0.18 (1.3)	0.12 (0.9)	0.099 (0.74)	0.091 (0.65)	0.091 (0.69)
400	Sinc3	1 (7.4)	0.53 (3.7)	0.28 (2)	0.17 (1.2)	0.11 (0.8)	0.09 (0.66)	0.083 (0.61)	0.083 (0.59)
400	Sinc4	0.95 (6.9)	0.51 (3.6)	0.27 (1.9)	0.15 (1.2)	0.1 (0.7)	0.084 (0.58)	0.077 (0.55)	0.077 (0.57)
1200	Sinc1	2.3 (17)	1.2 (9.2)	0.64 (5)	0.37 (2.9)	0.25 (1.9)	0.2 (1.6)	0.19 (1.4)	0.19 (1.5)
1200	Sinc2	1.9 (14)	1 (7.6)	0.54 (3.9)	0.31 (2.4)	0.21 (1.6)	0.17 (1.3)	0.16 (1.2)	0.16 (1.2)
1200	Sinc3	1.8 (13)	0.92 (7)	0.49 (3.7)	0.29 (2.2)	0.19 (1.4)	0.16 (1.2)	0.14 (1.1)	0.14 (1.1)
1200	Sinc4	1.6 (12)	0.86 (6.4)	0.46 (3.6)	0.27 (2)	0.18 (1.4)	0.15 (1.1)	0.13 (1)	0.13 (1)
2400	Sinc1	3.2 (25)	1.7 (13)	0.88 (6.7)	0.51 (3.9)	0.35 (2.7)	0.28 (2.2)	0.26 (2)	0.26 (2)
2400	Sinc2	2.7 (21)	1.4 (10)	0.76 (5.8)	0.44 (3.3)	0.3 (2.2)	0.24 (1.9)	0.22 (1.6)	0.22 (1.6)
2400	Sinc3	2.5 (19)	1.3 (9.8)	0.69 (5.2)	0.4 (3)	0.27 (2.1)	0.22 (1.7)	0.2 (1.6)	0.2 (1.5)
2400	Sinc4	2.3 (17)	1.2 (9.4)	0.65 (4.9)	0.37 (2.8)	0.25 (2)	0.21 (1.5)	0.19 (1.5)	0.19 (1.4)
4800	Sinc1	4.3 (33)	2.3 (17)	1.2 (9.4)	0.69 (5.2)	0.46 (3.5)	0.37 (2.9)	0.34 (2.6)	0.34 (2.6)
4800	Sinc2	3.8 (29)	2 (15)	1.1 (8.5)	0.61 (4.7)	0.41 (3.1)	0.33 (2.6)	0.31 (2.3)	0.3 (2.3)
4800	Sinc3	3.5 (27)	1.8 (14)	0.97 (7.2)	0.56 (4.1)	0.38 (3)	0.31 (2.4)	0.28 (2.1)	0.28 (2.2)
4800	Sinc4	3.3 (25)	1.7 (13)	0.92 (7.1)	0.53 (4.1)	0.36 (2.7)	0.29 (2.2)	0.27 (2.1)	0.27 (1.9)
7200	Sinc1	5 (38)	2.6 (20)	1.4 (10)	0.8 (6)	0.53 (4)	0.43 (3.2)	0.39 (2.9)	0.39 (2.9)
7200	Sinc2	4.6 (35)	2.4 (19)	1.3 (9.9)	0.73 (5.4)	0.49 (3.8)	0.39 (2.9)	0.36 (2.8)	0.36 (2.7)
7200	Sinc3	4.3 (33)	2.2 (17)	1.2 (9.3)	0.68 (5)	0.46 (3.6)	0.37 (2.8)	0.34 (2.5)	0.34 (2.6)
7200	Sinc4	4.1 (31)	2.1 (15)	1.1 (8.8)	0.65 (5)	0.44 (3.3)	0.35 (2.6)	0.33 (2.5)	0.32 (2.5)
14400	Sinc5	6 (47)	3.1 (24)	1.7 (13)	0.93 (7.1)	0.61 (4.9)	0.49 (3.8)	0.45 (3.5)	0.45 (3.4)
19200	Sinc5	8.5 (67)	4.3 (34)	2.3 (17)	1.2 (9.6)	0.77 (6)	0.57 (4.3)	0.54 (4)	0.53 (4.1)
25600	Sinc5	19 (140)	9.5 (73)	4.8 (37)	2.5 (18)	1.3 (10)	0.83 (6.3)	0.8 (6)	0.81 (6)
40000	Sinc5	30 (220)	15 (110)	7.7 (56)	3.9 (29)	2 (15)	1.2 (9.4)	1.2 (8.9)	1.2 (9)

**表 2. Effective Resolution (Noise-Free Resolution) at  $T_A = 25^\circ\text{C}$  and External 5-V Reference**

DATA RATE (SPS)	FILTER	GAIN							
		1	2	4	8	16	32	64	128
2.5	FIR	24 (24)	24 (22.8)	24 (23.8)	24 (23.8)	24 (23.8)	24 (22.8)	24 (22)	23 (20.8)
2.5	Sinc1	24 (24)	24 (22.8)	24 (23.8)	24 (23.8)	24 (22.8)	24 (22.8)	24 (22.4)	23.2 (21.2)
2.5	Sinc2	24 (24)	24 (22.8)	24 (23.8)	22.8 (23.8)	21.8 (22.8)	24 (23.8)	24 (22.4)	23.9 (22)
2.5	Sinc3	24 (24)	24 (22.8)	24 (23.8)	22.8 (23.8)	24 (23.8)	24 (23.8)	24 (22.4)	23.8 (22)
2.5	Sinc4	24 (24)	24 (22.8)	24 (23.8)	22.8 (23.8)	24 (23.8)	24 (23.8)	24 (23)	23.5 (22)
5	FIR	24 (23)	24 (22.8)	24 (23.8)	24 (22.8)	24 (22.2)	24 (21.8)	23.6 (21.7)	22.5 (20.7)
5	Sinc1	24 (23.7)	24 (23.8)	24 (23.8)	24 (22.8)	24 (22.2)	24 (22.8)	23.3 (21.4)	22.8 (20.7)
5	Sinc2	24 (24)	24 (23.8)	24 (23.8)	24 (23.8)	24 (23.8)	24 (22.8)	23.7 (21.7)	22.8 (21)
5	Sinc3	24 (24)	24 (23.8)	24 (23.8)	24 (23.8)	24 (23.8)	24 (22.8)	23.5 (21.4)	23.5 (21.7)
5	Sinc4	24 (24)	24 (23.8)	24 (23.8)	22.8 (23.8)	24 (23.8)	24 (23.8)	24 (22)	23.3 (21.2)
10	FIR	24 (22.4)	24 (22.8)	24 (22.8)	24 (22.2)	24 (21.8)	23.5 (21.2)	22.8 (20.5)	22.1 (19.9)
10	Sinc1	24 (23)	24 (22.8)	24 (22.8)	24 (22.8)	24 (22.2)	23.6 (21.2)	23.4 (21.2)	22.3 (19.8)
10	Sinc2	24 (23)	24 (22.8)	24 (22.8)	24 (22.8)	24 (22.2)	24 (22.2)	23.2 (21.4)	22.3 (20.2)
10	Sinc3	24 (24)	24 (22.8)	24 (23.8)	24 (23.8)	24 (22.8)	24 (22.2)	23.3 (21.2)	22.7 (20.7)
10	Sinc4	24 (24)	24 (22.8)	24 (23.8)	24 (22.8)	24 (22.8)	24 (22.2)	23.7 (21.4)	22.9 (20.8)
16.6	Sinc1	24 (22)	24 (21.8)	24 (22.2)	24 (21.8)	23.7 (21.2)	23.4 (21)	22.5 (20.3)	21.8 (19.6)
16.6	Sinc2	24 (22.4)	24 (22.8)	24 (22.2)	24 (22.2)	24 (21.8)	23.7 (21.2)	23 (20.7)	22 (19.5)
16.6	Sinc3	24 (23)	24 (22.8)	24 (22.2)	24 (22.8)	24 (22.8)	23.9 (21.5)	23.1 (21)	22 (19.8)
16.6	Sinc4	24 (23)	24 (22.8)	24 (22.8)	24 (22.8)	24 (22.2)	24 (21.5)	23.4 (20.7)	22.5 (20.1)
20	FIR	24 (22)	23.8 (21.5)	23.9 (21.8)	23.9 (21.5)	23.5 (21)	22.9 (20.5)	22.2 (19.8)	21.3 (18.7)
20	Sinc1	24 (22)	24 (22.2)	24 (21.8)	23.9 (21.8)	23.7 (21.5)	23.3 (21)	22.6 (20.3)	21.5 (19.2)
20	Sinc2	24 (23)	24 (22.2)	24 (22.2)	24 (21.8)	24 (21.8)	23.6 (21.2)	22.8 (20.3)	21.9 (19.6)
20	Sinc3	24 (22.4)	24 (22.8)	24 (22.2)	24 (22.8)	24 (21.8)	23.7 (21.5)	23 (20.7)	21.9 (19.4)
20	Sinc4	24 (23)	24 (22.8)	24 (22.8)	24 (22.2)	24 (22.2)	23.8 (21.2)	23.1 (20.7)	22 (19.4)
50	Sinc1	23.9 (21.4)	23.7 (21.5)	23.7 (21.2)	23.5 (20.8)	23.3 (20.6)	22.6 (20)	21.9 (19.3)	21 (18.6)
50	Sinc2	24 (21.7)	23.9 (21.5)	23.8 (21.2)	23.7 (21.5)	23.5 (20.8)	22.9 (20.2)	22.1 (19.3)	21.2 (18.8)
50	Sinc3	24 (22)	23.9 (21.5)	23.9 (21.5)	23.8 (21)	23.6 (21.2)	23 (20.5)	22.3 (19.8)	21.3 (18.6)
50	Sinc4	24 (22)	24 (21.8)	24 (21.8)	23.9 (21.5)	23.7 (21.2)	23.2 (20.8)	22.4 (20)	21.5 (18.9)
60	Sinc1	23.7 (21.4)	23.6 (21)	23.6 (21.2)	23.4 (20.8)	23.1 (20.5)	22.5 (19.9)	21.8 (19.1)	20.8 (18.2)
60	Sinc2	24 (21.4)	23.8 (21.5)	23.7 (21.2)	23.6 (21.2)	23.4 (20.8)	22.7 (20.2)	22.1 (19.3)	21.2 (18.5)
60	Sinc3	24 (21.7)	23.9 (21.5)	23.9 (21.5)	23.7 (21.2)	23.5 (20.8)	22.9 (20.5)	22.2 (19.5)	21.2 (18.8)
60	Sinc4	24 (22)	24 (21.8)	23.9 (21.5)	23.7 (21.2)	23.4 (20.6)	23 (20.2)	22.2 (19.5)	21.2 (18.7)
100	Sinc1	23.6 (21)	23.4 (20.6)	23.3 (20.5)	23.1 (20.4)	22.8 (20)	22.1 (19.4)	21.4 (18.8)	20.5 (17.7)
100	Sinc2	23.8 (21)	23.6 (21)	23.6 (21)	23.4 (21)	23 (20.2)	22.4 (19.7)	21.7 (19.1)	20.8 (18)
100	Sinc3	23.8 (21.2)	23.6 (21.2)	23.6 (21)	23.5 (21)	23.2 (20.5)	22.5 (19.9)	21.8 (19)	20.8 (17.9)
100	Sinc4	23.9 (21.4)	23.7 (21.2)	23.7 (21.2)	23.6 (21)	23.3 (20.6)	22.6 (19.7)	21.9 (19.4)	21 (18.1)
400	Sinc1	22.8 (19.8)	22.5 (19.7)	22.5 (19.6)	22.3 (19.6)	21.9 (19)	21.2 (18.2)	20.4 (17.6)	19.5 (16.6)
400	Sinc2	23.1 (20.3)	22.8 (20.1)	22.8 (20)	22.6 (19.6)	22.1 (19.2)	21.4 (18.6)	20.7 (17.9)	19.8 (17.1)
400	Sinc3	23.1 (20.4)	22.9 (20)	22.8 (19.9)	22.7 (20)	22.3 (19.4)	21.5 (18.7)	20.8 (17.8)	19.9 (17)
400	Sinc4	23.2 (20.3)	23 (20.2)	22.9 (20.1)	22.7 (20.1)	22.3 (19.5)	21.7 (18.9)	21 (18)	20 (17.2)
1200	Sinc1	22.1 (19.2)	21.8 (19.1)	21.7 (18.9)	21.6 (18.7)	21.1 (18.3)	20.4 (17.5)	19.7 (16.8)	18.8 (15.7)
1200	Sinc2	22.3 (19.5)	22.1 (19.3)	22 (19.1)	21.8 (18.9)	21.4 (18.4)	20.6 (17.7)	20 (17.1)	19 (16)
1200	Sinc3	22.4 (19.6)	22.2 (19.2)	22.1 (19.2)	21.9 (19)	21.5 (18.5)	20.8 (18)	20.1 (17.2)	19.2 (16.2)
1200	Sinc4	22.5 (19.6)	22.3 (19.6)	22.2 (19.2)	22 (19.1)	21.6 (18.7)	20.9 (18)	20.2 (17.3)	19.2 (16.4)
2400	Sinc1	21.6 (18.7)	21.4 (18.3)	21.3 (18.4)	21.1 (18.1)	20.7 (17.7)	19.9 (17.1)	19.2 (16.2)	18.3 (15.4)
2400	Sinc2	21.8 (18.8)	21.6 (18.6)	21.5 (18.6)	21.3 (18.5)	20.9 (18)	20.2 (17.3)	19.5 (16.6)	18.5 (15.6)

**表 2. Effective Resolution (Noise-Free Resolution) at  $T_A = 25^\circ\text{C}$  and External 5-V Reference (接下页)**

DATA RATE (SPS)	FILTER	GAIN							
		1	2	4	8	16	32	64	128
2400	Sinc3	21.9 (19.1)	21.7 (18.8)	21.6 (18.6)	21.4 (18.6)	21 (18.1)	20.3 (17.5)	19.6 (16.7)	18.7 (15.7)
2400	Sinc4	22 (19.1)	21.8 (19)	21.8 (19)	21.6 (18.6)	21.1 (18)	20.4 (17.5)	19.7 (16.7)	18.8 (15.9)
4800	Sinc1	21.1 (18.1)	20.9 (17.9)	20.9 (17.9)	20.6 (17.7)	20.2 (17.2)	19.5 (16.6)	18.8 (15.8)	17.9 (14.9)
4800	Sinc2	21.3 (18.4)	21.1 (18.1)	21 (18.1)	20.8 (17.9)	20.4 (17.4)	19.7 (16.6)	19 (16.1)	18 (14.9)
4800	Sinc3	21.4 (18.4)	21.2 (18.3)	21.1 (18.3)	21 (18)	20.5 (17.6)	19.8 (16.8)	19.1 (16.3)	18.2 (15.1)
4800	Sinc4	21.5 (18.6)	21.3 (18.4)	21.2 (18.2)	21.1 (18.1)	20.6 (17.7)	19.9 (17)	19.2 (16.3)	18.2 (15.3)
7200	Sinc1	20.9 (17.8)	20.7 (17.7)	20.6 (17.4)	20.4 (17.5)	20 (17)	19.3 (16.4)	18.6 (15.7)	17.7 (14.7)
7200	Sinc2	21 (18.1)	20.8 (17.9)	20.7 (17.9)	20.6 (17.6)	20.2 (17.2)	19.4 (16.4)	18.7 (15.9)	17.8 (14.9)
7200	Sinc3	21.1 (18.1)	20.9 (18.1)	20.8 (17.9)	20.6 (17.8)	20.2 (17.2)	19.5 (16.5)	18.8 (15.9)	17.9 (14.9)
7200	Sinc4	21.2 (18.1)	21 (18)	20.9 (18.1)	20.7 (18)	20.3 (17.2)	19.6 (16.7)	18.9 (15.9)	18 (15)
14400	Sinc5	20.5 (17.7)	20.3 (17.5)	20.2 (17.3)	20.1 (17.1)	19.8 (16.9)	19.1 (16.1)	18.4 (15.4)	17.5 (14.5)
19200	Sinc5	19.7 (16.8)	19.5 (16.5)	19.4 (16.5)	19.4 (16.3)	19.2 (16.2)	18.8 (15.9)	18 (15.1)	17 (14.2)
25600	Sinc5	18.2 (15.2)	18 (14.9)	18 (15.2)	17.9 (14.7)	17.9 (15.1)	17.8 (14.8)	17 (14.2)	16 (13.2)
40000	Sinc5	17.4 (14.6)	17.2 (14.2)	17.2 (14.2)	17.2 (14.3)	17.2 (14.2)	17.1 (14.3)	16.3 (13.4)	15.3 (12.5)

## 9 Detailed Description

### 9.1 Overview

The ADS1260 and ADS1261 are 5-channel and 10-channel, precision 24-bit, delta-sigma ( $\Delta\Sigma$ ) ADCs with an integrated analog front end (AFE) and voltage reference. The low-noise and low-drift architecture make the ADCs suitable for precision measurement of low signal level sensors, such as strain-gauge bridges, pressure transducers and temperature sensors.

Key features of the ADC are:

- Very low noise, 1-G $\Omega$  input impedance PGA
- High-precision, 24-bit  $\Delta\Sigma$  ADC
- Internal oscillator
- 2.5-V voltage reference
- Signal and voltage reference monitors
- Excitation current sources
- Input level-shift voltage
- Sensor burn-out current sources
- Temperature sensor
- Cyclic redundancy check (CRC) communication error detection
- Two voltage reference inputs ( ADS1261)
- Four GPIO with AC-excitation ( ADS1261)

The analog inputs (AINx) connect to the input multiplexer (MUX). The ADC supports three (five) differential or five (ten) single-ended input configurations for the ADS1260 and ADS1261, respectively.

The programmable gain amplifier (PGA) follows the input multiplexer. The PGA is suitable for direct connection to low-level sensors. The gain is programmable from 1 to 128. The PGA bypass option connects the analog inputs directly to the precharge buffered modulator, extending the input voltage range to the power supplies. The PGA output connects to pins CAPP and CAPN. The ADC antialias filter is provided at the PGA output with an external capacitor.

The PGA is monitored to verify linear operation. Alarm bits in the status register set if the linear range of the PGA is exceeded.

A delta-sigma modulator measures the input voltage relative to the reference voltage to produce the 24-bit conversion result. The differential input range of the ADC is  $\pm V_{REF} / \text{Gain}$ .

The digital filter averages and decimates the modulator output data to yield the final, down-sampled conversion result. The sinc filter is programmable (sinc1 through sinc5) allowing optimization of conversion time, conversion noise and line-cycle rejection. The finite impulse response (FIR) filter mode provides single-cycle settled data with simultaneous rejection of 50-Hz and 60-Hz at data rates of 20 SPS or less.

The ADC reference is either 2.5-V internal, external or the 5-V analog power supply. The REFOUT pin provides the buffered reference voltage output. The external reference is monitored for low or missing voltage. The ADS1261 provides two voltage reference inputs, multiplexed with the analog inputs.

The ADC includes two current sources that provide excitation to resistive sensors (RTD). Additionally, the ADS1261 provides four GPIO control lines. The GPIOs are used for input and output of general-purpose logic signals, as well as providing drive signals for AC-excited bridges. The GPIOs are multiplexed to the analog inputs.

The temperature sensor and the power supply voltages are read through the multiplexer. The programmable burn-out test currents connect to the multiplexer output. The currents detect failed sensors or faults in the sensor connection. The level-shift voltage on AINCOM provides the bias for floating sensors.

The SPI-compatible serial interface is used to read the conversion data and also to configure and control the ADC. Data communication errors are detected by CRC. The serial interface consists of four signals:  $\overline{CS}$ , SCLK, DIN and DOUT/ $\overline{DRDY}$ . The dual function DOUT/ $\overline{DRDY}$  provides data output and also the data ready signal. The ADC serial interface can be implemented with as little as three pins by tying  $\overline{CS}$  low.

## Overview (接下页)

The ADC clock is either internal or external. The ADC detects the external clock automatically. The nominal clock frequency is 7.3728 MHz (10.24 MHz for 40-kSPS operation).

ADC conversions are controlled by the START pin or by the START command. The ADC is programmable for continuous or one-shot conversions. The DRDY or DOUT/DRDY pin provides the conversion data ready signal. When taken low, the RESET pin resets the ADC. The ADC is powered down by the PWDN pin or is powered down in software mode.

The ADC operates in either bipolar analog supply configuration ( $\pm 2.5$  V), or in a single 5-V supply configuration. The digital power supply range is 2.7 V to 5 V. The BYPASS pin is the internal subregulator output used for the ADC digital core.

## 9.2 Functional Block Diagram

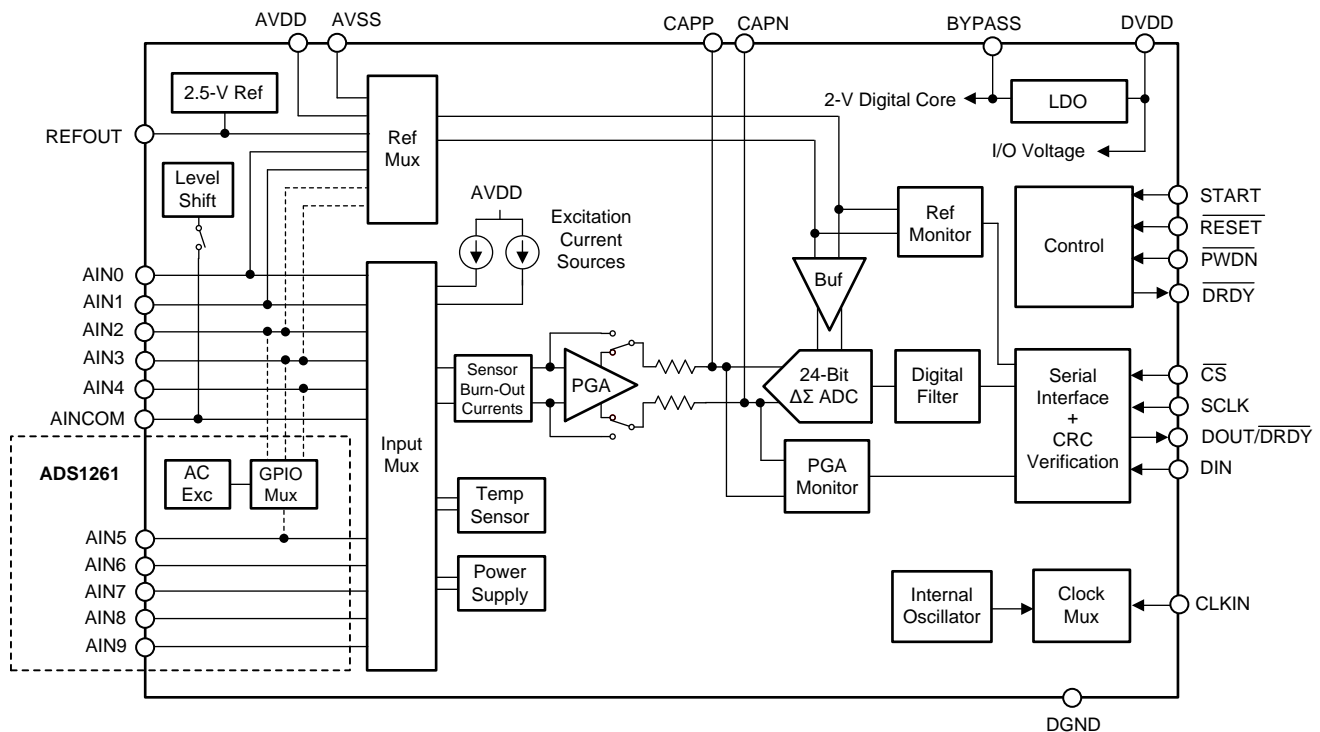

### 9.3 Feature Description

The following sections describe the functional blocks of the ADC.

#### 9.3.1 Analog Inputs

图 48 shows the analog input circuit consist of ESD-protection diodes, the input multiplexer and sensor burn-out current sources. The ADS1260 has six analog inputs to support five single-ended measurement channels. The ADS1261 has 11 analog inputs to support 10 single-ended measurement channels. Both devices have four internal (system) measurements, and an option where no inputs are connected.



图 48. Analog Input Block Diagram

##### 9.3.1.1 ESD Diodes

ESD diodes are incorporated to protect the ADC inputs from possible ESD events occurring during the manufacturing process and during PCB assembly when manufactured in an ESD-controlled environment. For system-level ESD protection, consider the use of external ESD protection devices for pins that are exposed to ESD, including the analog inputs.

If either input is driven below  $AVSS - 0.3\text{ V}$ , or above  $AVDD + 0.3\text{ V}$ , the internal protection diodes may conduct. If these conditions are possible, use external clamp diodes, series resistors, or both to limit the input current to the specified maximum value.

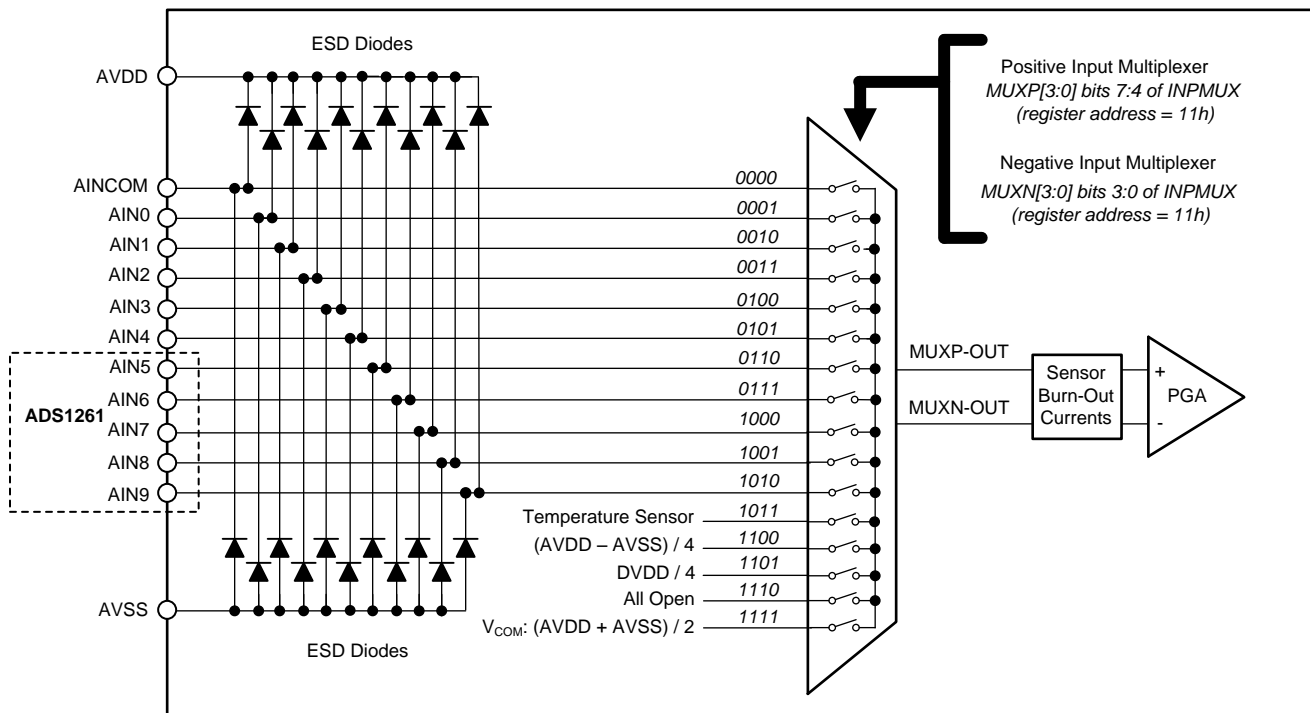
##### 9.3.1.2 Input Multiplexer

The input multiplexer selects the signal for measurement. The multiplexer consists of independent positive and negative sections. See 图 48 for multiplexer register settings. The multiplexers select any input as positive and any input as negative for the PGA. Because the level-shift voltage connects to AINCOM (only), AINCOM is suitable as the common input for single-ended signals that require a level-shift voltage.

The switching sequence of the multiplexer is break-before-make in order to reduce charge injection into the next measurement channel. Be aware that over-driving unused channels beyond the power supplies can effect conversions taking place on active channels. See the [Input Overload](#) section for more information.

## Feature Description (接下页)

### 9.3.1.3 Temperature Sensor

The ADC has an internal temperature sensor. The temperature sensor is comprised of two internal diodes with one diode having 80 times the current density of the other. The difference in current density of the diodes yields a differential output voltage that is proportional to absolute temperature. The temperature sensor reading is converted by the ADC. See [图 48](#) for register settings to select the temperature sensor for measurement.

[公式 2](#) shows how to convert the temperature sensor reading to degrees Celsius (°C):

$$\text{Temperature (}^\circ\text{C)} = [(\text{Temperature Reading (}\mu\text{V)} - 122,400) / 420 \mu\text{V}^\circ\text{C}] + 25^\circ\text{C} \quad (2)$$

Measure the temperature sensor with PGA on, gain = 1, burn-out current sources disabled and AC-excitation mode disabled. As a result of the low package-to-PCB thermal resistance, the internal temperature closely tracks the PCB temperature. Be aware that device self-heating increases the internal temperature relative to the surrounding PCB.

### 9.3.1.4 Power-Supply Readback

Read the power-supply voltage by the appropriate input multiplexer selection. The supply voltages are divided to reduce the voltage levels to within the ADC input range. The analog and digital supply readback levels are scaled by [公式 3](#) and [公式 4](#), respectively:

$$\text{Analog supply (V)} = (\text{AVDD} - \text{AVSS}) / 4 \quad (3)$$

$$\text{Digital supply (V)} = \text{DVDD} / 4 \quad (4)$$

Measure the power supply voltages with either the internal or an external reference. If using an external reference, the minimum reference voltage is 1.5 V. Perform the measurement with PGA enabled, gain = 1, burn-out current sources disabled and AC-excitation mode disabled. See [图 48](#) for register settings to measure the supply voltages.

### 9.3.1.5 Inputs Open

This configuration opens all inputs. Use this configuration to test the functionality of the sensor burn-out current sources, and the PGA output monitors. When the inputs are open, the current sources drive the PGA inputs to full scale, resulting in an PGA monitor alarm and clipped conversion data. See [图 48](#) for register settings to open all inputs.

### 9.3.1.6 Internal $V_{\text{COM}}$ Connection

For this multiplexer configuration, all inputs are open and the PGA inputs are connected to an internal  $V_{\text{COM}}$  voltage as defined:  $(\text{AVDD} + \text{AVSS}) / 2$ . Use this mode to measure the ADC noise performance and offset voltage, or to short the inputs for offset calibration. See [图 48](#) for register settings of the internal  $V_{\text{COM}}$  connection.

## Feature Description (接下页)

### 9.3.1.7 Alternate Functions

The ADC has several alternate functions that are multiplexed with the analog inputs. The alternate functions are reference input, current source output, GPIO, AC-excitation and level-shift voltage output. The functions are enabled by programming of the associated registers. The analog inputs retain measurement ability if the alternate functions are programmed. 表 3 summarizes the alternate functions.

表 3. Analog Input Alternate Functions

ANALOG INPUTS		REFERENCE INPUTS	CURRENT SOURCES	GPIO/AC-EXCITATION <sup>(1)</sup>	LEVEL-SHIFT VOLTAGE
ADS1260	ADS1261				
AINCOM	AINCOM	—	Yes	—	Yes
AIN0	AIN0	REFP0	Yes	—	—
AIN1	AIN1	REFN0	Yes	—	—
AIN2	AIN2	REFP1 <sup>(1)</sup>	Yes	GPIO0/ACX1	—
AIN3	AIN3	REFN1 <sup>(1)</sup>	Yes	GPIO1/ACX2	—
AIN4	AIN4	—	Yes	GPIO2/ACX1	—
—	AIN5	—	Yes	GPIO3/ACX2	—
—	AIN6	—	Yes	—	—
—	AIN7	—	Yes	—	—
—	AIN8	—	Yes	—	—
—	AIN9	—	Yes	—	—

(1) ADS1261 and ADS1261B only.

### 9.3.2 PGA

The PGA is a low-noise, CMOS differential-input, differential-output amplifier. The PGA extends the dynamic range of the ADC, important when used with low level sensors. The PGA provides gains of 1 through 32 and the ADC provides additional gains of 2 and 4. The combined gains are 1 through 128. Gain is controlled by the GAIN[2:0] register bits as shown in 图 49. In PGA bypass mode, the input voltage range extends to the analog supplies. The PGA is powered down in bypass mode.



图 49. PGA Block Diagram

The PGA consists of two chopper-stabilized amplifiers (A1 and A2), and a resistor network that determines the PGA gain. The resistor network is precision matched, providing low drift performance. The PGA integrates noise filters to reduce sensitivity to electromagnetic-interference (EMI). The PGA output is monitored to indicate when the operating headroom is exceeded.

Pins CAPP and CAPN are the PGA positive and negative outputs, respectively. Connect an external 4.7-nF capacitor (type C0G) as shown in [图 49](#). The capacitor filters the modulator sample pulses and with the internal resistors, forms the antialias filter. Place the capacitor as close as possible to the pins using short traces. Avoid running clock traces or other digital traces close to these pins.

The full-scale differential input voltage range of the ADC is determined by the reference voltage and gain. [表 4](#) shows the differential input voltage range verses gain for  $V_{REF} = 2.5$  V.

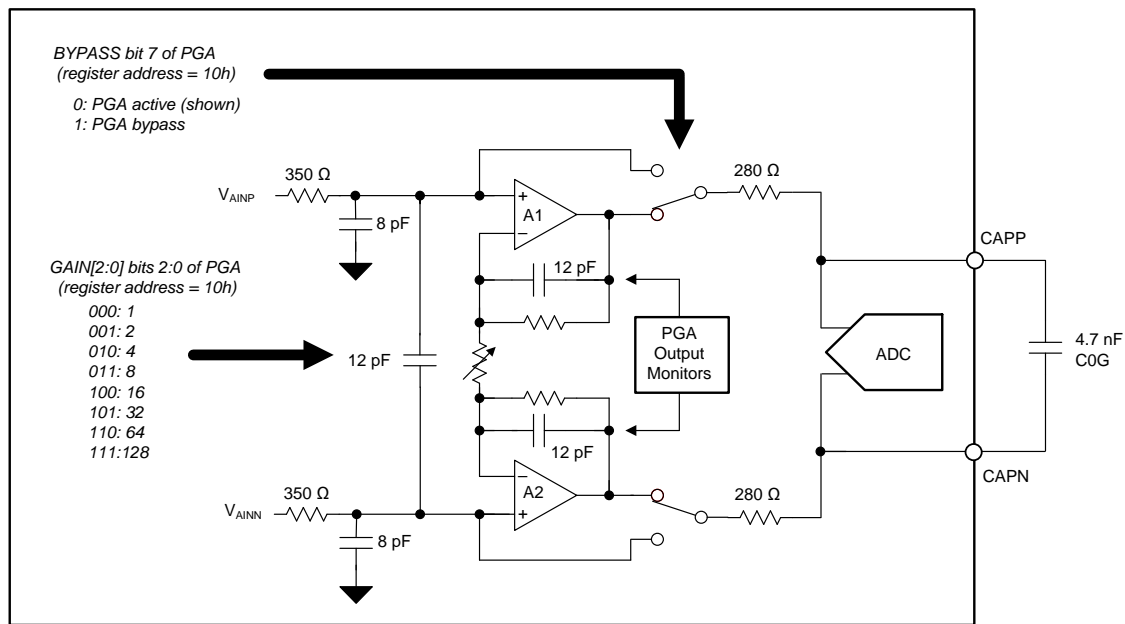
**表 4. Full-Scale Voltage Range**

GAIN[2:0] BITS	GAIN	FULL-SCALE DIFFERENTIAL INPUT RANGE <sup>(1)</sup>
000	1	±2.500 V
001	2	±1.250 V
010	4	±0.625 V
011	8	±0.312 V
100	16	±0.156 V
101	32	±0.078 V
110	64	±0.039 V
111	128	±0.0195 V

(1)  $V_{REF} = 2.5$  V. Full scale differential input voltage range is proportional to  $V_{REF}$ .

As with many amplifiers, the PGA has an input voltage range limitation that must not be exceeded in order to maintain linear operation. The specified input voltage range is expressed as the absolute voltage at the positive and negative inputs. As specified in [公式 5](#), the specified absolute input voltage depends on gain, the expected maximum differential voltage, and the minimum analog power-supply voltage.

$$AVSS + 0.3 \text{ V} + V_{IN} \cdot (\text{Gain} - 1) / 2 < V_{AINP} \text{ and } V_{AINN} < AVDD - 0.3 \text{ V} - V_{IN} \cdot (\text{Gain} - 1) / 2$$

where

- $V_{AINP}$ ,  $V_{AINN}$  = absolute input voltage
- $V_{IN}$  = maximum differential input voltage =  $V_{AINP} - V_{AINN}$
- Gain (for gains = 64 and 128, use gain = 32 in the calculation)
- AVDD = minimum AVDD voltage
- AVSS = maximum AVSS voltage

(5)

The relationship of the PGA input to the PGA output is shown graphically in [Figure 50](#). The PGA output voltages ( $V_{OUTP}$ ,  $V_{OUTN}$ ) depend on the respective absolute input voltage, the differential input voltage, and the PGA gain. To maintain the PGA within the linear operating range, the PGA output voltages must not exceed either  $AVDD - 0.3\text{ V}$  or  $AVSS + 0.3\text{ V}$ . The diagram depicts a positive differential input voltage that results in a positive differential output voltage.

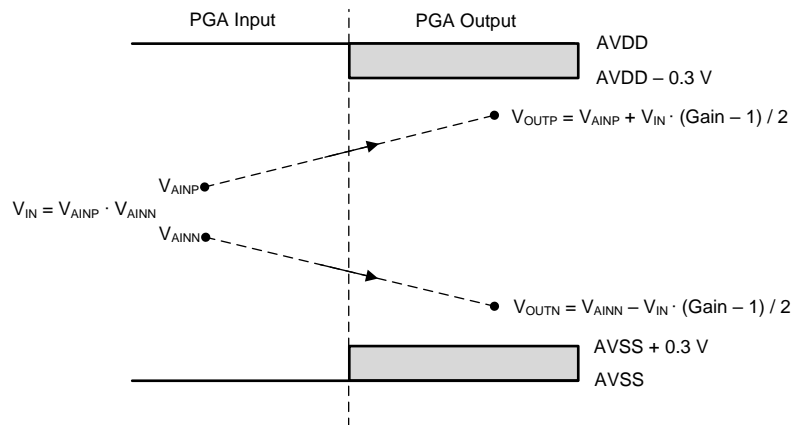

**图 50. PGA Input/Output Range**

**9.3.2.1 PGA Bypass Mode**

Bypass the PGA to extend the input voltage range up to the analog power supply voltages. In bypass mode, the PGA is bypassed and the analog inputs are connected directly to the precharge buffers of the modulator, thereby extending the input voltage range. Be aware of the increased analog input current in bypass mode. See the [Recommended Operating Conditions](#) for the bypass-mode input voltage range specification, and see the [Electrical Characteristics](#) for the input current specification.

**9.3.2.2 PGA Voltage Monitor**

The PGA has voltage monitors to provide indication when the PGA is overloaded. In overload condition, the conversion data are no longer valid. If either the PGA positive or negative output exceeds  $AVDD - 0.2\text{ V}$ , the high alarm bit is set (PGAH\_ALM). Similarly, if either PGA positive or negative output is less than  $AVSS + 0.2\text{ V}$ , the low alarm bit is set (PGAL\_ALM). The monitor alarm state is read in the STATUS byte. The monitor alarm is read-only and automatically resets at the start of the next conversion cycle after the overload condition is cleared. The monitor diagram and threshold values are shown in [Figure 51](#) and [Figure 52](#).

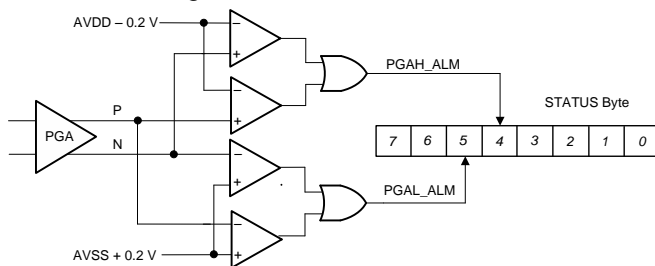

**图 51. PGA Monitor Diagram**

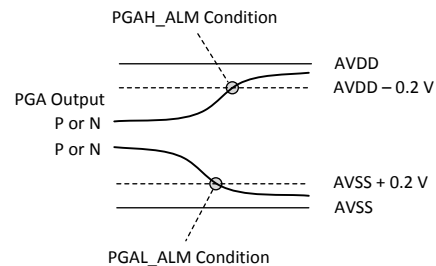

**图 52. PGA Monitor Thresholds**

The PGA monitors consist of fast-responding voltage comparators. Comparator operation is disabled during multiplexer changes to minimize the false triggering during these input switching events. However, it is possible the monitors can detect other transient overload conditions that may occur after gain changes, sensor connection changes, and so on.

### 9.3.3 Reference Voltage

The ADC requires a reference voltage for operation. The reference voltage options are 2.5-V internal, one or two external inputs (ADS1260 or ADS1261, respectively) or the 5-V analog power supply. The reference voltage is selected by independent positive and negative reference multiplexers for the reference positive and reference negative voltages, respectively. The default reference is the 5-V analog power supply (AVDD – AVSS). 图 53 shows the block diagram of the reference multiplexer.

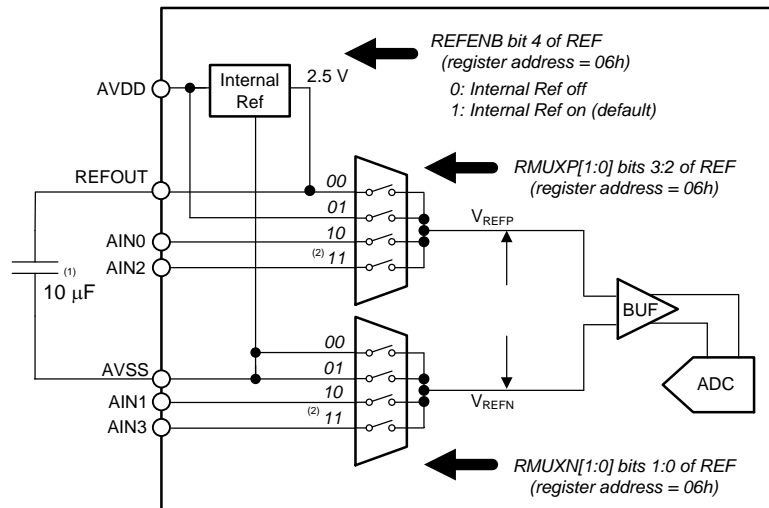

- (1) The internal reference requires a 10- $\mu$ F capacitor connected to pins REFOUT and AVSS.
- (2) ADS1261 only.

图 53. Reference Input Diagram

Program the RMUXP[1:0] and RMUXN[1:0] bits of the REF register to select the positive and negative reference voltages, respectively. The positive reference selections are internal positive, AIN0, AIN2, or AVDD. The negative reference input selections are internal negative, AIN1, AIN3, or AVSS. The reference low-voltage monitor is located after the reference multiplexer. See the [Reference Monitor](#) section for more information.

#### 9.3.3.1 Internal Reference

The ADC incorporates a 2.5-V reference that is enabled by the REFENB bit of the REF register (default = off). Program the reference multiplexer bits RMUXP[1:0] and RMUXN[1:0] to 00b to select the internal reference. A 10- $\mu$ F capacitor is required between pins REFOUT and AVSS to filter reference noise. REFOUT is the reference output and AVSS is the reference return. Use a star-layout connection or plane connection for the reference return, connecting close to the AVSS pin. When the reference is enabled, be aware of the settling time before beginning conversions. Also be aware of the reference inrush current that may result in a transient droop of the AVDD voltage. Enable the internal reference for sensor excitation current source operation.

#### 9.3.3.2 External Reference

Use an external reference by applying the reference voltage to the designated analog inputs. The reference inputs are differential with positive and negative inputs. Program the reference multiplexer bits RMUXP[1:0] and RMUXN[1:0] to 10b or 11b to select inputs AIN0/AIN1 or AIN2/AIN3, respectively (AIN2/AIN3 is available only for the ADS1261). For application that use multiple references, it is possible to connect the reference grounds together and use a single input pin for ground. Follow the specified absolute and differential reference voltage operating conditions, as specified in the [Recommended Operating Conditions](#). Connect a 100-nF capacitor across the reference input pins to filter noise. Be aware of the reference input current if reference impedances are present. Consider the error to the overall system accuracy.

**9.3.3.3 AVDD - AVSS Reference (Default)**

A third reference option is the 5-V analog power supply (AVDD - AVSS). Select this reference option by setting the reference multiplexer bits RMUXP[1:0] and RMUXN[1:0] to 01b. For a 6-wire load cell application that uses excitation sense lines, or for AC-excitation operation, connect the excitation sense lines to the analog input reference inputs and program the ADC for external reference operation.

**9.3.3.4 Reference Monitor**

The ADC incorporates a reference monitor that detects an invalid reference voltage. As shown in 图 54 and 图 55, if the reference voltage ( $V_{REF} = V_{REFP} - V_{REFN}$ ) is below 0.4 V, the REFL\_ALM bit is set in the STATUS byte. The alarm is read-only and resets at the next conversion after the low reference condition is cleared.

Use the reference monitor to detect a missing or failed reference voltage. To implement detection of a missing reference, use a 100-kΩ resistor across the reference inputs. If either input is unconnected, the resistor biases the differential reference input towards 0 V so that the missing reference can be detected.



图 54. Reference Monitor



图 55. Reference Monitor Threshold

**9.3.4 Level-Shift Voltage (VBIAS)**

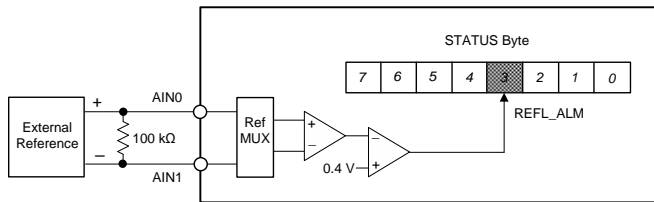
The ADC integrates a level-shift voltage that can be connected to the AINCOM pin by an internal switch. As shown in 图 56, the level-shift voltage is the mid-voltage between AVDD and AVSS. The purpose of the voltage is to shift the signal level of floating sensors to within the input range of the ADC. Isolated thermocouples and piezoelectric sensors are examples of sensors that are suitable for connection to the level-shift voltage. For these sensors, connect the negative lead to the AINCOM pin and enable the level-shift voltage.

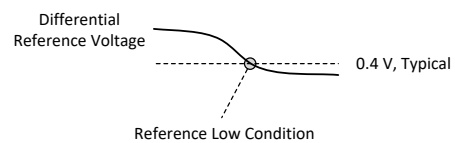

图 56. Level-Shift Voltage Diagram

The turn-on time of the level-shift voltage depends on the total external capacitance connected from the AINCOM pin to ground or AVSS. 表 5 lists the level-shift voltage settling times for various load capacitance. Be certain the level-shift voltage is fully settled before starting a conversion.

表 5. Level-Shift Enable Time

LOAD CAPACITANCE	LEVEL-SHIFT VOLTAGE SETTling TIME
0.1 μF	0.22 ms
1 μF	2.2 ms
10 μF	22 ms

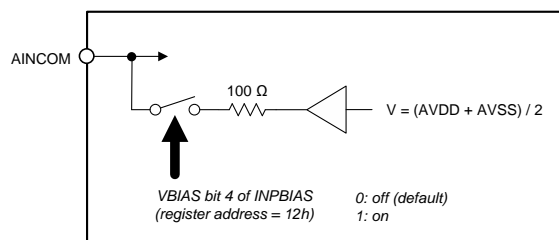
### 9.3.5 Burn-Out Current Sources

The burn-out current sources are used to detect the occurrence of sensor burn-out or break. If the sensor or sensor connection is open, the currents drive either or both positive and negative PGA inputs to opposite supply voltages where the occurrence of an open sensor is detected by the PGA monitors or detected by the host for out-of-range (or clipped) conversion data.

图 57 shows the burn-out currents connect at the output of the analog input multiplexer. The currents sink and source, and are configurable in pullup or pulldown mode. In pullup mode, the sourcing current connects to the positive input channel and the sinking current connects to the negative input channel. In this configuration, an open circuit pulls the inputs to positive full scale. The currents are Off, 0.050  $\mu\text{A}$ , 0.2  $\mu\text{A}$ , 1  $\mu\text{A}$ , and 10  $\mu\text{A}$ . See the [Burn-Out Current Source](#) section for application information.



图 57. Burn-Out Current Sources

### 9.3.6 Sensor-Excitation Current Sources (IDAC1 and IDAC2)

The ADC incorporates two current sources that are used to provide excitation current to a resistive temperature device (RTD), thermistor, diode and other sensor type that require constant current biasing. The currents are programmable over the 50  $\mu\text{A}$  to 3000  $\mu\text{A}$  range and are internally multiplexed to all analog input pins. The current source multiplexer is shown in [Figure 58](#). The IMUX1 and IMUX2 register bits connect the corresponding current source to the analog inputs. The IMAG1 and IMAG2 register bits program the corresponding current magnitude.

Enable the internal reference for current source operation. The current source value can be doubled or an intermediate value produced by connecting the current sources to the same analog input. Take care not to exceed the current source compliance voltage range. That is, when the current source is loaded by resistance, the voltage at the pin increases and must not exceed specification; otherwise the specified current source accuracy is not met.

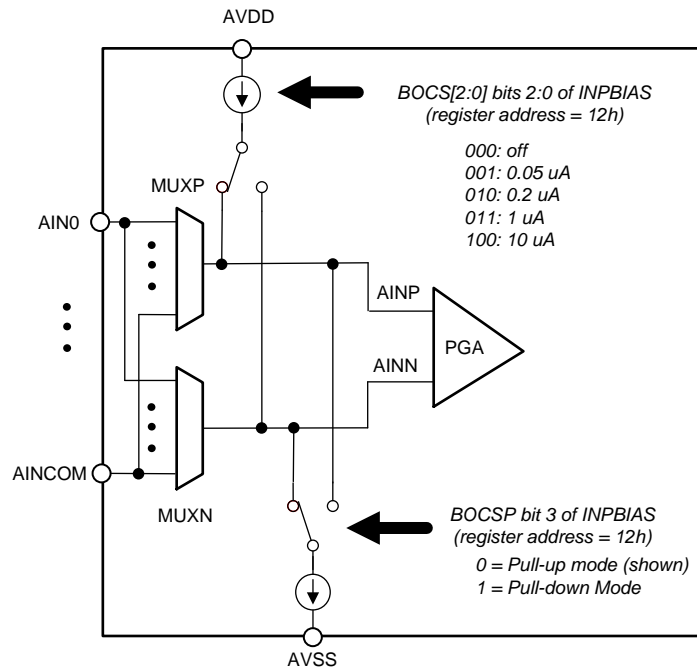
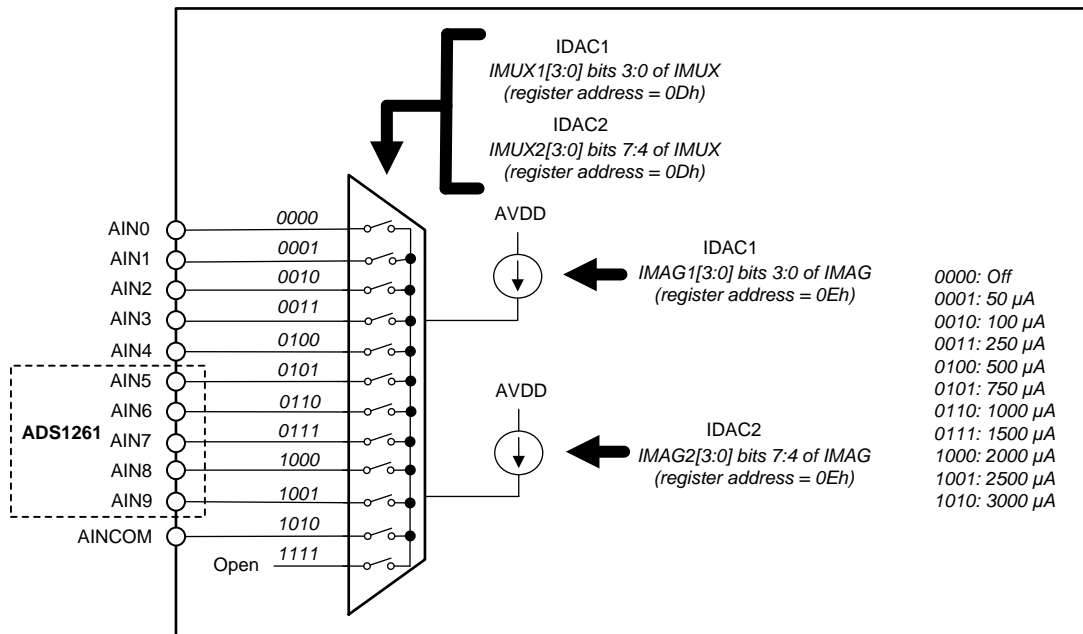

**图 58. Current Source Connection**

### 9.3.7 General-Purpose Input/Outputs (GPIOs)

The ADS1261 and ADS1261B devices provide four GPIO pins, GPIO0 through GPIO3. The GPIOs are digital inputs/outputs that are referenced to analog AVDD and AVSS. The GPIOs are read and written by the GPIO\_DAT bits of register MODE3. The GPIOs are multiplexed with analog inputs AIN2 to AIN5. As shown in Figure 59, the GPIOs have a series of programming registers. Bits GPIO\_CON[3:0] connect the GPIOs to the associated pin (1 = connect). Bits GPIO\_DIR program the direction of the GPIOs; (0 = output, 1 = input). The input voltage threshold is the voltage value between AVDD and AVSS. Bits GPIO\_DAT[3:0] are the data values for the GPIOs. Observe that if a GPIO pin is programmed as an output, the value read is the value previously written to the register data, not the actual state of the pin.

The GPIOs also provide the AC-excitation drive signals. AC-excitation mode override the GPIO register data values. See the [AC-Excitation Mode](#) section for details.



图 59. GPIO Block Diagram

### 9.3.8 Oversampling

The ADC operates on the principle of oversampling, defined as the ratio of the sample rate of the modulator to that of the ADC output data rate. Oversampling improves ADC noise by digital bandwidth limiting (low-pass filtering) of the data. The digital filter also performs data rate reduction (decimation) in order to reduce the data rate proportional with the amount of data filtering.

### 9.3.9 Modulator

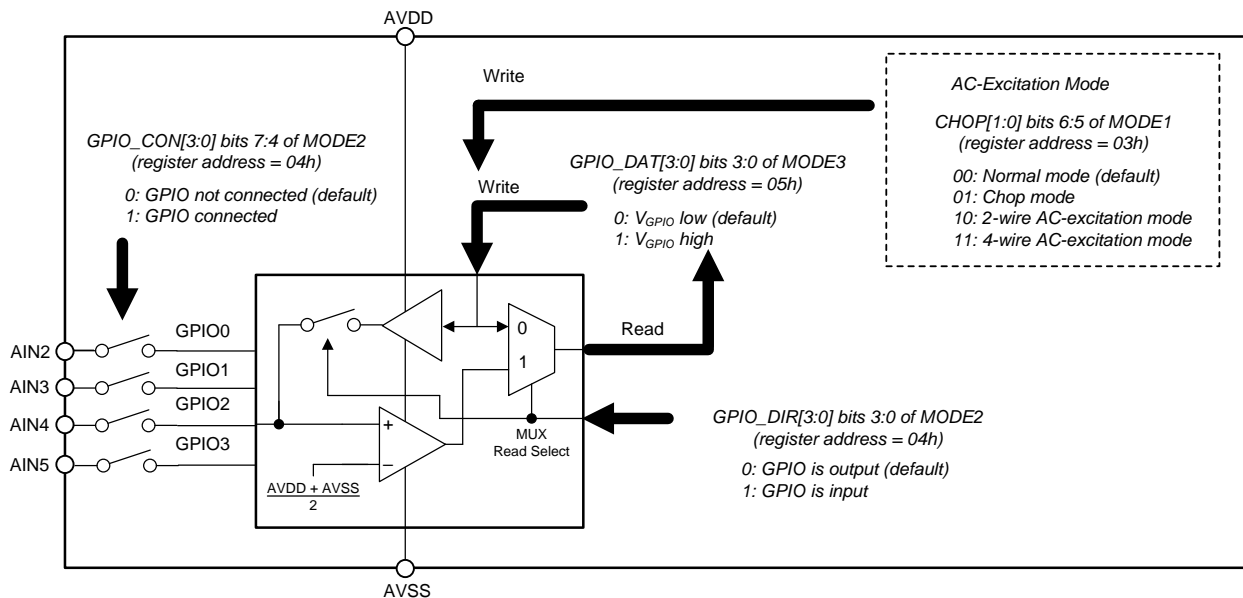
The modulator is an inherently stable, fourth-order, 2 + 2 pipelined  $\Delta\Sigma$  modulator. The modulator samples the analog input voltage at a high sample rate ( $f_{MOD} = f_{CLK} / 8$ ) and converts the analog input to a ones-density bit-stream given by the ratio of the input signal to the reference voltage. The modulator shapes the noise of the converter to high frequency, where the noise is removed by the digital filter.

### 9.3.10 Digital Filter

The digital filter receives the modulator output data and produces a high-resolution conversion result. The digital filter low-pass filters and decimates the modulator data (data rate reduction), yielding the final data output. By adjusting the type of filtering, tradeoffs are made between resolution, data throughput and line cycle rejection.

The digital filter has two selectable modes:  $\sin(x)/x$  (sinc) mode and finite impulse response (FIR) mode (see [图 60](#)). The sinc mode provides data rates of 2.5 SPS through 40000 SPS with variable sinc orders of 1 through 5. The FIR filter provides simultaneous rejection of 50-Hz and 60-Hz frequencies with data rates 2.5 SPS through 20 SPS while providing single-cycle settled conversions.



图 60. Digital Filter Block Diagram

#### 9.3.10.1 Sinc Filter

The sinc filter is composed of two stages: a variable-decimation sinc5 filter, followed by a variable-decimation, variable-order sinc filter. The first stage filters and down-samples the modulator data to yield data rates of 40000 SPS, 25600 SPS, 19200 SPS, and 14400 SPS. These data rates bypass the second stage and as a result have a sinc5 characteristic filter response. The second stage receives data from the first stage at a fixed rate of 14400 SPS. The data rate is reduced to the range 7200 SPS to 2.5 SPS, with programmable orders of sinc.

The data rate is programmed by the DR[4:0] bits of register MODE0. The filter mode is programmed by the FILTER[2:0] bits of register MODE0 (see [表 32](#)).

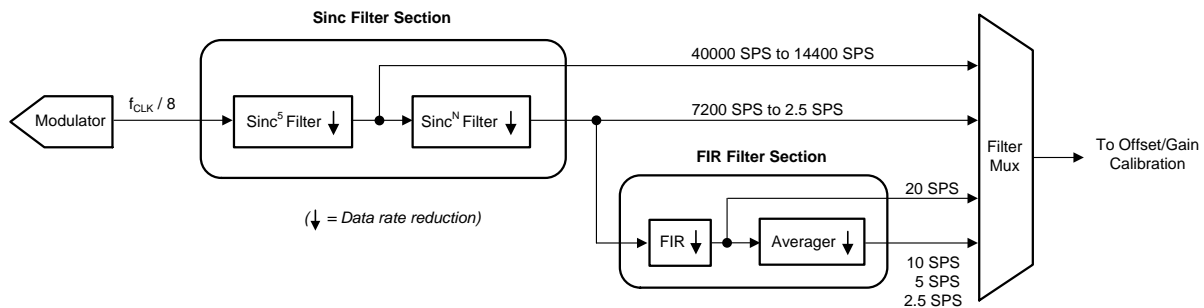
##### 9.3.10.1.1 Sinc Filter Frequency Response

The characteristic of the sinc filter is low pass. The filter reduces noise present in the signal and noise present within the ADC. Changing the data rate and filter order changes the filter bandwidth.

As shown in [图 61](#) and [图 62](#), the first-stage sinc5 filter has frequency response nulls occurring at  $N \cdot f_{DATA}$ , where  $N = 1, 2, 3$  and so on. At the null frequencies, the filter has zero gain. Data rates of 25600 SPS and 19200 SPS have similar frequency response.



图 61. Frequency Response (40000 SPS)



图 62. Frequency Response (14400 SPS)

The second stage superimposes frequency response nulls to the nulls of the first stage 14400 SPS output. The first of the superimposed response nulls occurs at the data rate, followed by nulls occurring at multiples of the data rate. 图 63 illustrates the frequency response for various orders of sinc at data rate of 2400 SPS. This data rate has five nulls between the larger nulls at multiples of 14400 Hz. This frequency response is similar to that of data rates 2.5 SPS to 7200 SPS. 图 64 shows the frequency response nulls for 10 SPS.

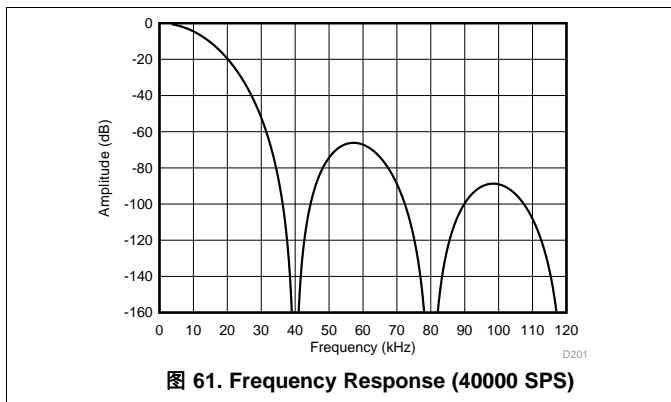

图 65 and 图 66 show the frequency response of data rates 50 SPS and 60 SPS, respectively. Increase the attenuation at 50 Hz or 60 Hz and harmonics by increasing the order of the sinc filter, as shown in the figures.

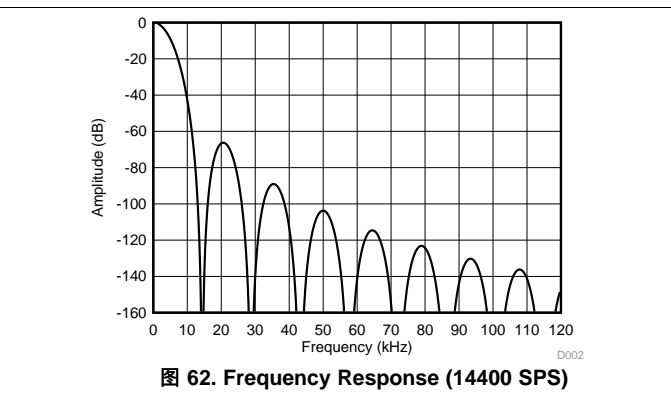

图 67 and 图 68 show the detailed frequency response at 50 SPS and 60 SPS, respectively.

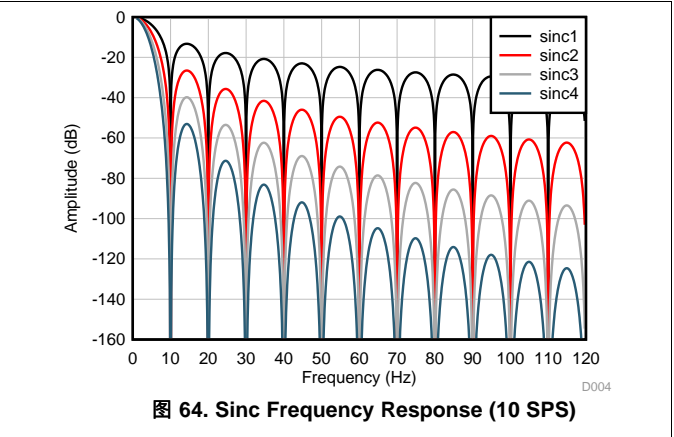
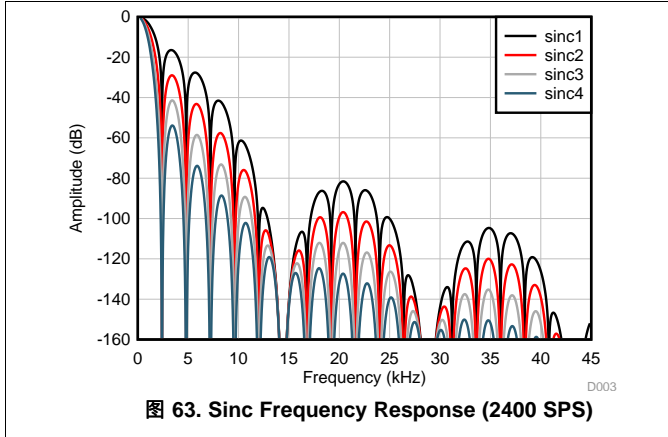

### 9.3.10.2 FIR Filter

The finite impulse response (FIR) filter is a coefficient based filter architecture that provides an overall low-pass filter response. The filter provides simultaneous attenuation of 50 Hz and 60 Hz and harmonics at data rates of 20 SPS to 2.5 SPS. The conversion latency time of the FIR filter data rates are single-cycle. As shown in 图 60, the FIR filter receives pre-filtered data from the sinc filter. The FIR filter decimates the data to yield the output data rates of 20 SPS. A variable averager (sinc1) provides data rates of 10 SPS, 5 SPS, and 2.5 SPS. 表 6 lists the bandwidth of the data rates in FIR filter mode.

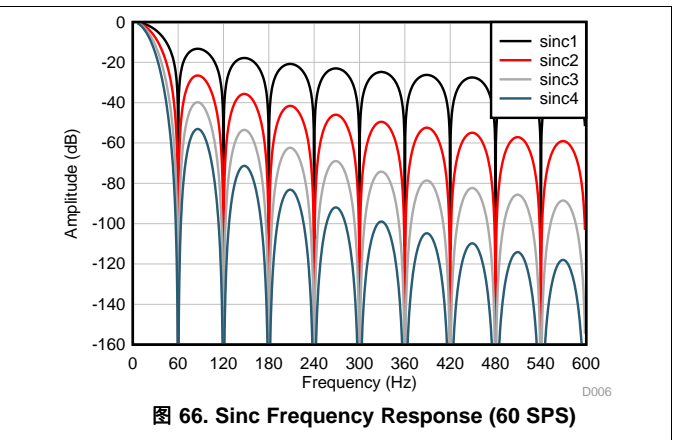
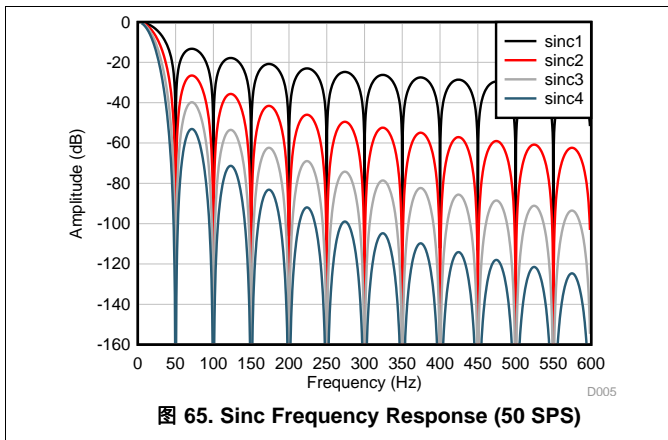
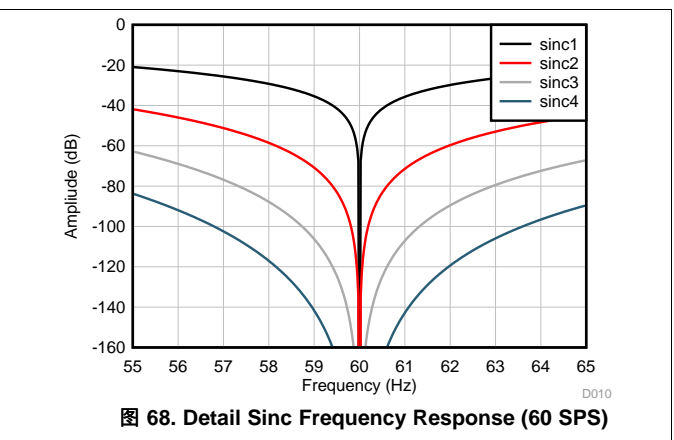
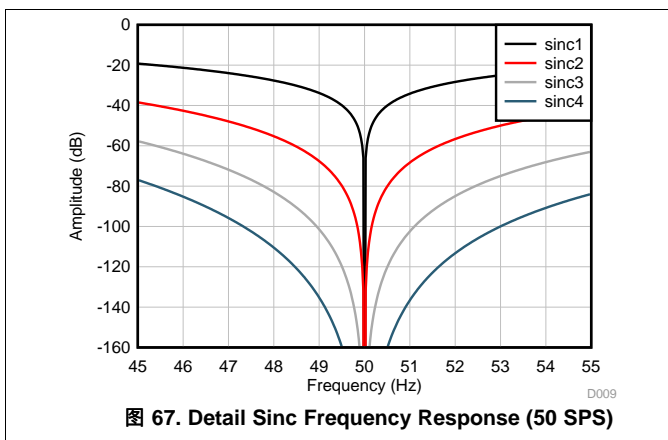
#### 9.3.10.2.1 FIR Filter Frequency Response

图 69 and 图 70 show the FIR filter frequency attenuates 50 Hz and 60 Hz by a series of response nulls placed close to these frequencies. The response nulls are repeated at harmonics of 50 Hz and 60 Hz.



图 71 is the FIR filter response at 10 SPS. As a result of the variable averager, new frequency nulls are superimposed. The first null appears at the data rate. Additional nulls occur at frequencies folded around multiples of 20 Hz.



图 71. FIR Frequency Response (10 SPS)

### 9.3.10.3 Filter Bandwidth

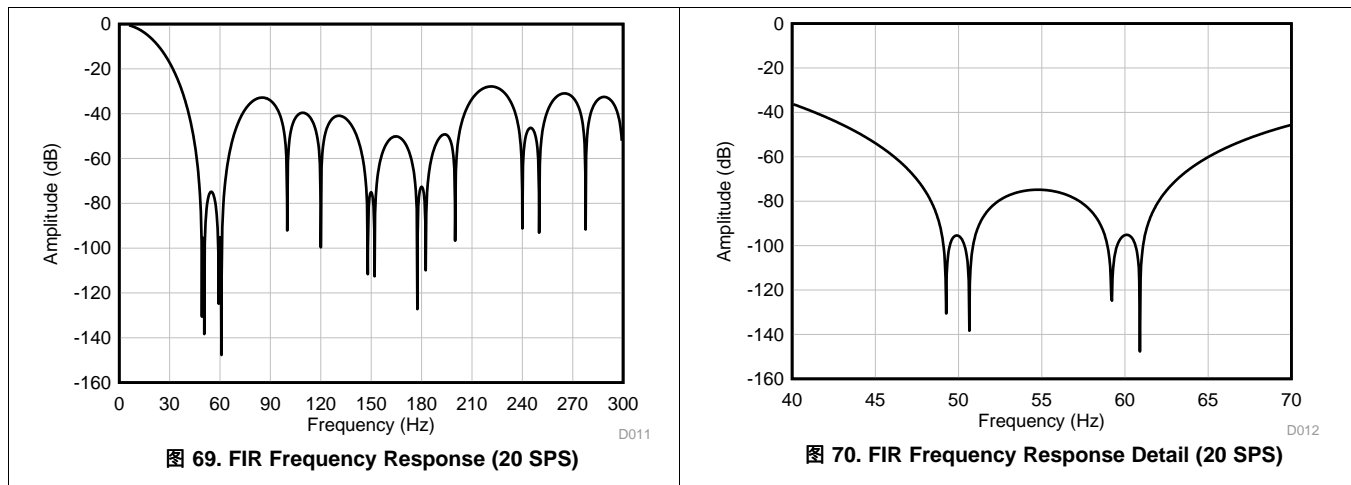
The bandwidth of the filter depends on the data rate and the filter mode. Be aware that the bandwidth of the entire system is the combined response of the filter, the antialias filter and external filters. 表 6 lists the bandwidth versus data rate and filter mode. 表 6 also lists the filter modes available for each data rate.

**表 6. Filter Bandwidth**

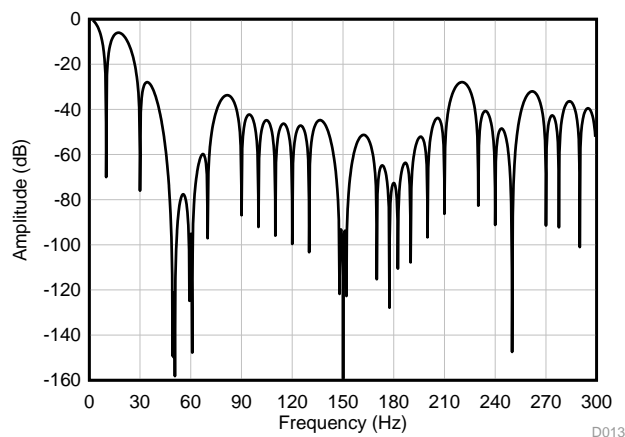
DATA RATE (SPS)	-3-dB BANDWIDTH (Hz)					
	FIR	SINC1	SINC2	SINC3	SINC4	SINC5
2.5	1.2	1.10	0.80	0.65	0.58	—
5	2.4	2.23	1.60	1.33	1.15	—
10	4.7	4.43	3.20	2.62	2.28	—
16.6	—	7.38	5.33	4.37	3.80	—
20	13	8.85	6.38	5.25	4.63	—
50	—	22.1	16.0	13.1	11.4	—
60	—	26.6	19.1	15.7	13.7	—
100	—	44.3	31.9	26.2	22.8	—
400	—	177	128	105	91.0	—
1200	—	525	381	314	273	—
2400	—	1015	751	623	544	—
4800	—	1798	1421	1214	1077	—
7200	—	2310	1972	1750	1590	—
14400	—	—	—	—	—	2940
19200	—	—	—	—	—	3920
25600	—	—	—	—	—	5227
40000	—	—	—	—	—	8167

### 9.3.10.4 50-Hz and 60-Hz Normal Mode Rejection

To reduce 50-Hz and 60-Hz noise interference, configure the conversion period to reject the noise at 50 Hz and 60 Hz. 50-Hz and 60-Hz noise rejection depends on the filter type. 表 7 summarizes the 50-Hz and 60-Hz noise rejection versus data rate and filter type. The table values are based on 2% and 6% tolerance of noise frequency to ADC clock frequency. For the sinc filter mode, noise rejection is increased by increasing the order of the filter. Common mode noise is also rejected at these frequencies.

表 7. 50-Hz and 60-Hz Normal Mode Rejection

DATA RATE (SPS)	FILTER TYPE	DIGITAL FILTER RESPONSE (dB)			
		50 Hz $\pm$ 2%	60 Hz $\pm$ 2%	50 Hz $\pm$ 6%	60 Hz $\pm$ 6%
2.5	FIR	-113	-99	-88	-80
2.5	Sinc1	-36	-37	-40	-37
2.5	Sinc2	-72	-74	-80	-74
2.5	Sinc3	-108	-111	-120	-111
2.5	Sinc4	-144	-148	-160	-148
5	FIR	-111	-95	-77	-76
5	Sinc1	-34	-34	-30	-30
5	Sinc2	-68	-68	-60	-60
5	Sinc3	-102	-102	-90	-90
5	Sinc4	-136	-136	-120	-120
10	FIR	-111	-94	-73	-68
10	Sinc1	-34	-34	-25	-25
10	Sinc2	-68	-68	-50	-50
10	Sinc3	-102	-102	-75	-75
10	Sinc4	-136	-136	-100	-100
16.6	Sinc1	-34	-21	-24	-21
16.6	Sinc2	-68	-42	-48	-42
16.6	Sinc3	-102	-63	-72	-63
16.6	Sinc4	-136	-84	-96	-84
20	FIR	-95	-94	-66	-66
20	Sinc1	-18	-34	-18	-24
20	Sinc2	-36	-68	-36	-48
20	Sinc3	-54	-102	-54	-72
20	Sinc4	-72	-136	-72	-96
50	Sinc1	-34	-15	-24	-15
50	Sinc2	-68	-30	-48	-30
50	Sinc3	-102	-45	-72	-45
50	Sinc4	-136	-60	-96	-60
60	Sinc1	-13	-34	-12	-24
60	Sinc2	-27	-68	-24	-48
60	Sinc3	-40	-102	-36	-72
60	Sinc4	-53	-136	-48	-96

## 9.4 Device Functional Modes

### 9.4.1 Conversion Control

Conversions are controlled by either the START pin or by the START command. If using commands to control conversions, keep the START pin low to avoid contentions between pin and commands. Commands take effect on the 16th falling SCLK edge (CRC mode disabled) or on the 32nd falling SCLK edge (CRC mode enabled). See [Figure 4](#) for conversion-control timing details.

The ADC provides two conversion modes: continuous and pulse. The continuous-conversion mode performs conversions indefinitely until stopped by the user. Pulse-conversion mode performs one conversion and then stops. The conversion mode is programmed by the CONVRT bit (bit 4 of register MODE0).

#### 9.4.1.1 Continuous-Conversion Mode

This conversion mode performs continuous conversions until stopped by the user. To start conversions, take the START pin high or send the START command.  $\overline{\text{DRDY}}$  is driven high at the time the conversion is initiated.  $\overline{\text{DRDY}}$  is driven low when the conversion data are ready. Conversion data are available to read at that time. Conversions are stopped by taking the START pin low or by sending the STOP command. When conversions are stopped, the conversion in progress runs to completion. To restart a conversion that is in progress, toggle the START pin low-then-high or send a new START command.

#### 9.4.1.2 Pulse-Conversion Mode

In pulse-conversion mode, the ADC performs one conversion when START is taken high or when the START command is sent. When the conversion completes, further conversions stop. The  $\overline{\text{DRDY}}$  output is driven high to indicate the conversion is in progress, and is driven low when the conversion data are ready. Conversion data are available to read at that time. To restart a conversion in progress, toggle the START pin low-then-high or send a new START command. Driving START low or sending the STOP command does not interrupt the current conversion.

#### 9.4.1.3 Conversion Latency

The digital filter averages data from the modulator in order to produce the conversion result. The stages of the digital filter must have settled data in order to provide fully-settled output data. The order and the decimation ratio of the digital filter determine the amount of data averaged, and in turn, affect the latency of the conversion data. The FIR and sinc1 filter modes are zero latency because the ADC provides the conversion result in one conversion cycle. Latency time is an important consideration for the data throughput rate in multiplexed applications.

[Table 8](#) lists the conversion latency values of the ADC. Conversion latency is defined as the time from the start of the first conversion, by taking the START pin high or sending the START command, to the time when the conversion data are ready. If the input signal is settled, then the ADC provides fully settled data under this condition. The conversion latency values listed in the table are with the start-conversion delay parameter = 50  $\mu\text{s}$ , and include the overhead time needed to process the data. After the first conversion completes (in continuous conversion mode), the period of the following conversions are equal to  $1/f_{\text{DATA}}$ . The first conversion latency in chop and AC-excitation modes are twice the values listed in the table. Also when operating in these modes, the period of the following conversions are equal to the values listed in the table.

**Device Functional Modes (接下页)**
**表 8. Conversion Latency**

DATA RATE (SPS)	CONVERSION LATENCY - $t_{(STDR)}^{(1)}$ (ms)					
	FIR	SINC1	SINC2	SINC3	SINC4	SINC5
2.5	402.2	400.4	800.4	1,200	1,600	—
5	202.2	200.4	400.4	600.4	800.4	—
10	102.2	100.4	200.4	300.4	400.4	—
16.6	—	60.43	120.4	180.4	240.4	—
20	52.23	50.43	100.4	150.4	200.4	—
50	—	20.43	40.43	60.43	80.43	—
60	—	17.09	33.76	50.43	67.09	—
100	—	10.43	20.43	30.43	40.43	—
400	—	2.925	5.425	7.925	10.43	—
1200	—	1.258	2.091	2.925	3.758	—
2400	—	0.841	1.258	1.675	2.091	—
4800	—	0.633	0.841	1.050	1.258	—
7200	—	0.564	0.702	0.841	0.980	—
14400	—	—	—	—	—	0.423
19200	—	—	—	—	—	0.336
25600	—	—	—	—	—	0.271
40000	—	—	—	—	—	0.179

(1) Chop mode off, conversion-start delay = 50  $\mu$ s (DELAY[3:0] = 0001)

If the input signal changes while free-running conversions, the conversion data are a mix of old and new data, as shown in 图 72. After an input change, the number of conversion periods required for fully settled data are determined by dividing the conversion latency by the period of the data rate, plus add one conversion period to the result. In chop mode and AC-excitation mode, use twice the latency values listed in the table.

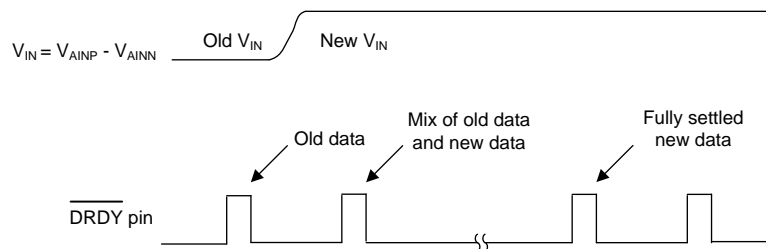
**图 72. Input Change During Conversions**
**9.4.1.4 Start-Conversion Delay**

Some applications may require a delay at the start of a conversion in order to allow settling time for the PGA output antialias filter or to allow time after input and configuration changes. The ADC provides a user programmable delay time that delays the start of a new conversion. The default value is 50  $\mu$ s. This allows for settling of the antialiasing filter. Use additional delay time as needed to provide settling time for external components. The delay time increases the conversion latency values listed in 表 8. As an alternative to the programmable start-conversion delay, manually delay the start of conversion after input and configuration changes.

Start-conversion delay is an important consideration for operation in AC-excitation mode. In this mode, the reference inputs to the bridge, and therefore, the bridge output signals are reversed for each conversion. As a result, time delay is required to allow for settling of external filter components after reversal. As a general guideline, set the start-conversion delay parameter to a minimum of 15 times the R-C time constant of the signal input and reference input filters.

### 9.4.2 Chop Mode

The PGA and modulator are chopper-stabilized at high frequency in order to reduce offset voltage, offset voltage drift and 1/f noise. The offset and noise artifacts are modulated to high frequency and are removed by the digital filter. Although chopper stabilization is designed to remove all offset, a small offset voltage may remain. The optional *global* chop mode removes the remaining offset errors, providing exceptional offset voltage drift performance.

Chop mode alternates the signal polarity of consecutive conversions. The ADC subtracts consecutive, alternate-phase conversions to yield the final conversion data. The result of subtraction removes the offset.



图 73. ADC Chop Mode

As shown in 图 73, the internal chop switch reverses the signal after the input multiplexer.  $V_{OFS}$  models the internal offset voltage. The operational sequence of chop mode is as follows:

**Conversion C1:**  $V_{AINP} - V_{AINN} - V_{OFS} \rightarrow$  First conversion withheld after start

**Conversion C2:**  $V_{AINN} - V_{AINP} - V_{OFS} \rightarrow$  Output 1 =  $(C1 - C2) / 2 = V_{AINP} - V_{AINN}$

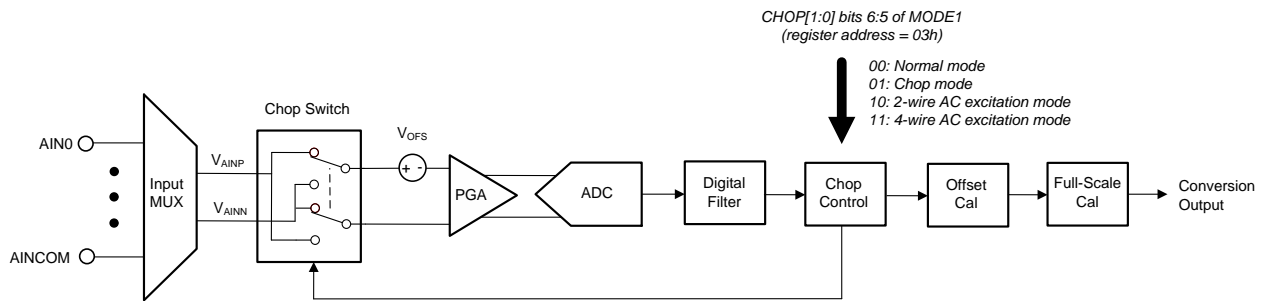
**Conversion C3:**  $V_{AINP} - V_{AINN} - V_{OFS} \rightarrow$  Output 2 =  $(C3 - C2) / 2 = V_{AINP} - V_{AINN}$

The sequence repeats for all conversions. Because of the internal mathematical operations, the chop mode data rate is reduced. The chop mode data rate is proportional to the order of the sinc filter. Referring to 表 8, the new data rate is equal to 1 / latency values and the first conversion latency is  $2 \times$  latency values. Because of the two-point data averaging arising from the mathematical operations, noise is reduced by  $\sqrt{2}$ . For chop mode, divide the noise data values shown in 表 1 by  $\sqrt{2}$  to derive the new noise performance data. The null frequencies of the digital filter are not changed in chop-mode operation. However, new null frequencies appear at multiples of  $f_{DATA} / 2$ .

### 9.4.3 AC-Excitation Mode

Resistive bridge sensors are excited by DC or AC voltages; for DC or AC currents. DC voltage excitation is the most common type of excitation. AC excitation reverses the polarity of the voltage by the use of external switching components. Similar in concept to chop mode, the result of the voltage reversal removes offset voltage in the connections leading from the bridge to the ADC inputs. This removal includes the offset voltage of the ADC itself. The ADS1261 and ADS1261B devices provide the signals necessary to drive the external switching components in order to reverse the bridge voltage.

The timing of the drive signals is synchronized to the ADC conversion phase. During one conversion phase, the voltage polarity is normal. For the alternate conversion phase, the voltage polarity is reversed. The ADC compensates the reversed polarity conversion by internal reversal of the reference voltage. The ADC subtracts the data corresponding to the normal and reverse phases in order to remove offset voltage from the input.

The ADC output drive signals do not overlap in order to avoid bridge cross-conduction that can otherwise occur during excitation voltage reversal. The switch rate of the AC-excitation drive signals are at the data rate to avoid unnecessary fast switching. See 图 7 for output drive timing.

表 9 shows the AC-excitation drive signals and the associated GPIO pins. Program the AC-excitation mode using the CHOP[1:0] bits in register MODE1. AC excitation can be programmed for two-wire or four-wire drive mode. For two-wire operation, two drive signals are provided on the GPIOs. If needed, use two external inverters to derive four signals to drive discrete transistors. The GPIO drive levels are referred to the 5-V analog supply. Be aware that the AC-excitation mode changes the nominal data rate, depending on the order of the sinc filter. See the [Chop Mode](#) section for details of the effective data rate.

**表 9. AC-Excitation Drive Pins**

DEVICE PIN	GPIO	2-WIRE MODE (CHOP[1:0] = 10)	4-WIRE MODE (CHOP[1:0] = 11)
AIN2	GPIO0	$\overline{ACX1}$	$\overline{ACX1}$
AIN3	GPIO1	$\overline{ACX2}$	$\overline{ACX2}$
AIN4	GPIO2	—	ACX1
AIN5	GPIO3	—	ACX2

#### 9.4.4 ADC Clock Mode

Operate the ADC with an external clock or with the internal oscillator. The clock frequency is 7.3728 MHz, except for  $f_{DATA} = 40000$  SPS then  $f_{CLK} = 10.24$  MHz (internal or external). For external clock operation, apply the clock signal to CLKIN. For internal-clock operation, connect CLKIN to DGND. The internal oscillator begins operation immediately at power-up. The ADC automatically selects the clock mode of operation. Read the clock mode bit in the STATUS register to determine the clock mode.

#### 9.4.5 Power-Down Mode

The ADC has two power-down modes: hardware and software. In both power-down modes, the digital outputs remain driven. The digital inputs must be maintained at  $V_{IH}$  or  $V_{IL}$  levels (do not float the digital inputs). The internal low-dropout regulator remains on, drawing 25  $\mu$ A (typical) from DVDD.

##### 9.4.5.1 Hardware Power-Down

Take the  $\overline{PWDN}$  pin low to engage hardware power-down mode. Except for the internal LDO, all ADC functions are disabled. To exit hardware power-down mode (wake-up) take the  $\overline{PWDN}$  pin high. The register values are not reset at wake-up. The internal reference is shut down in this mode; therefore, be sure to accommodate the start-up time of the internal reference before starting conversions.

##### 9.4.5.2 Software Power-Down

Set the PWDN bit (bit 7 of register MODE3) to engage software power-down mode. Similar to the operation of hardware power-down mode, software mode powers down the internal functions except the serial interface remains powered, and the internal reference bias is unchanged (On or Off). Exit the software power-down mode by clearing the PWDN bit. The register values are not reset.

#### 9.4.6 Reset

The ADC is reset in three ways: at power-on, by the  $\overline{RESET}$  pin, and by the RESET command. When reset, the serial interface, conversion-control logic, digital filter, and register values are reset. The RESET bit of the STATUS byte is set to indicate a device reset has occurred by any of the three reset methods. Clear the bit to detect the next device reset. If the START pin is high after reset, the ADC begins conversions.

##### 9.4.6.1 Power-on Reset

At power-on, after the supply voltages cross the reset-voltage thresholds, the ADC is reset and  $2^{16} f_{CLK}$  cycles later the ADC is ready for communication. Until this time,  $\overline{DRDY}$  is held low.  $\overline{DRDY}$  is driven high to indicate when the ADC is ready for communication. If the START pin is high, the conversion cycle starts  $512 / f_{CLK}$  cycle after  $\overline{DRDY}$  asserts high. 图 5 shows the power-on reset behavior.

##### 9.4.6.2 Reset by Pin

Reset the ADC by taking the  $\overline{RESET}$  pin low and then returning the pin high. After reset, the conversion starts  $512 / f_{CLK}$  cycles later. See 图 6 for RESET timing.

### 9.4.6.3 Reset by Command

Reset the ADC by the RESET command. Toggle  $\overline{CS}$  high to make sure the serial interface resets before sending the command. For applications that tie  $\overline{CS}$  low, see the [Serial Interface Auto-Reset](#) section for information on how to reset the serial interface. After reset, the conversion starts 512 /  $f_{CLK}$  cycles later. See [图 6](#) for timing details.

### 9.4.7 Calibration

The ADC incorporates calibration registers and associated commands to calibrate offset and full-scale errors. Calibrate by using calibration commands, or calibrate by writing to the calibration registers directly (user calibration). To calibrate by command, send the offset or full-scale calibration commands. To user calibrate, write values to the calibration registers based on calculations of the conversion data. Perform offset calibration before full-scale calibration.

#### 9.4.7.1 Offset and Full-Scale Calibration

Use the offset and full-scale (gain) registers to correct offset or full-scale errors, respectively. As shown in [图 74](#), the offset calibration register is subtracted from the output data before multiplication by the full-scale register, which is divided by 400000h. After the calibration operation, the final output data are clipped to 24 bits.



图 74. Calibration Block Diagram

[公式 6](#) shows the internal calibration.

$$\text{Final Output Data} = (\text{Filter Output} - OFCAL[2:0]) \cdot FSCAL[2:0] / 400000h \quad (6)$$

#### 9.4.7.1.1 Offset Calibration Registers

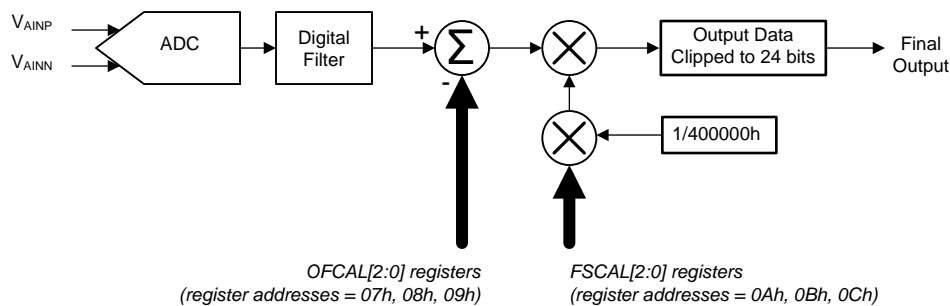
The offset calibration word is 24 bits, consisting of three 8-bit registers, as listed in [表 10](#). The offset value is subtracted from the conversion result. The offset value is in two's complement format with a maximum positive value equal to 7FFFFFFh, and a maximum negative value equal to 800000h. A register value equal to 000000h has no offset correction. Although the offset calibration register provides a wide range of possible offset values, the input signal after calibration cannot exceed  $\pm 106\%$  of the pre-calibrated range; otherwise, the ADC is overranged. [表 11](#) lists example values of the offset register.

表 10. Offset Calibration Registers

REGISTER	BYTE ORDER	ADDRESS	BIT ORDER							
			B7	B6	B5	B4	B3	B2	B1	B0 (LSB)
OFCAL0	LSB	07h	B7	B6	B5	B4	B3	B2	B1	B0 (LSB)
OFCAL1	MID	08h	B15	B14	B13	B12	B11	B10	B9	B8
OFCAL2	MSB	09h	B23 (MSB)	B22	B21	B20	B19	B18	B17	B16

表 11. Offset Calibration Register Values

OFCAL[2:0] REGISTER VALUE	IDEAL OUTPUT VALUE <sup>(1)</sup>
000001h	FFFFFFh
000000h	000000h
FFFFFFh	000001h

(1) Output value with no offset error

### 9.4.7.1.2 Full-Scale Calibration Registers

The full-scale calibration word is 24 bits consisting of three 8-bit registers, as listed in 表 12. The full-scale calibration value is in straight-binary format, normalized to a unity-gain factor at a value of 400000h. 表 13 lists register values for selected gain factors. Gain errors greater than unity are corrected by using full-scale values less than 400000h. Although the full-scale register provides a wide range of possible values, the input signal after calibration must not exceed  $\pm 106\%$  of the precalibrated input range; otherwise, the ADC is overranged.

**表 12. Full-Scale Calibration Registers**

REGISTER	BYTE ORDER	ADDRESS	BIT ORDER							
			B7	B6	B5	B4	B3	B2	B1	B0 (LSB)
FSCAL0	LSB	0Ah	B7	B6	B5	B4	B3	B2	B1	B0 (LSB)
FSCAL1	MID	0Bh	B15	B14	B13	B12	B11	B10	B9	B8
FSCAL2	MSB	0Ch	B23 (MSB)	B22	B21	B20	B19	B18	B17	B16

**表 13. Full-Scale Calibration Register Values**

FSCAL[2:0] REGISTER VALUE	GAIN FACTOR
433333h	1.05
400000h	1.00
3CCCCCh	0.95

### 9.4.7.2 Offset Self-Calibration (SFOCAL)

The offset self-calibration command corrects offset errors internal to the ADC. When the offset self-calibration command is sent, the ADC disconnects the external inputs, shorts the inputs to the PGA, and then averages 16 conversion results to compute the calibration value. Averaging the data reduces conversion noise to improve calibration accuracy. When calibration is complete, the ADC restores the user input and performs one conversion using the new calibration value.

### 9.4.7.3 Offset System-Calibration (SYOCAL)

The offset system-calibration command corrects system offset errors. For this type of calibration, the user shorts the inputs to either the ADC or to the system. When the command is sent, the ADC averages 16 conversion results to compute the calibration value. Averaging the data reduces conversion noise to improve calibration accuracy. When calibration is complete, the ADC performs one conversion using the new calibration value.

### 9.4.7.4 Full-Scale Calibration (GANCAL)

The full-scale calibration command corrects gain error. To calibrate, apply a positive full-scale calibration voltage to the ADC, wait for the signal to settle, and then send the calibration command. The ADC averages 16 conversion results to compute the calibration value. Averaging the data reduces conversion noise to improve calibration accuracy. The ADC computes the full-scale calibration value so that the calibration voltage is scaled to positive full scale output code. When calibration is complete, the ADC performs one new conversion using the new calibration value.

### 9.4.7.5 Calibration Command Procedure

Use the following procedure to calibrate using commands. The register-lock mode must be UNLOCK for all calibration commands. After power-on, make sure the reference voltage has stabilized before calibrating. Perform offset calibration before full-scale calibration.

1. Configure the ADC as required.
2. Apply the appropriate calibration signal (zero or full-scale)
3. Take the START pin high or send the START command to start conversions.  $\overline{\text{DRDY}}$  is driven high.
4. Before the conversion cycle completes, send the calibration command. Keep  $\overline{\text{CS}}$  low otherwise the command is cancelled. Send no other commands during the calibration period.
5. Calibration time depends on the data rate and digital filter mode. See 表 14.  $\overline{\text{DRDY}}$  asserts low when calibration is complete. The offset or full-scale calibration registers are updated with new values. At calibration completion, new conversion data are ready using the new calibration value.

**表 14. Calibration Time (ms)**

DATA RATE (SPS)	FILTER MODE <sup>(1)</sup>					
	FIR	SINC1	SINC2	SINC3	SINC4	SINC5
2.5	6805	6801	7601	8401	9201	—
5	3405	3401	3801	4201	4601	—
10	1705	1701	1901	2101	2301	—
16.6	—	1021	1141	1261	1381	—
20	854.5	850.9	951.0	1051	1151	—
50	—	340.9	380.9	420.9	460.9	—
60	—	284.2	317.5	350.9	384.2	—
100	—	170.9	190.9	210.9	230.9	—
400	—	43.36	48.36	53.36	58.36	—
1200	—	15.02	16.69	18.36	20.02	—
2400	—	7.938	8.772	9.605	10.44	—
4800	—	4.397	4.813	5.230	5.647	—
7200	—	3.216	3.494	3.772	4.050	—
14400	—	—	—	—	—	1.892
19200	—	—	—	—	—	1.458
25600	—	—	—	—	—	1.133
40000	—	—	—	—	—	0.738

(1) Nominal clock frequency. Chop and AC-excitation modes disabled.

### 9.4.7.6 User Calibration Procedure

To user calibrate, apply the calibration voltage, acquire conversion data, and compute the calibration value. The computed value is written to the corresponding calibration registers. Before starting calibration, preset the offset and full-scale registers to 000000h and 400000h, respectively.

To offset calibrate, short the ADC inputs (or inputs to the system) and average n number of the conversion results. Averaging conversion data reduces noise to improve calibration accuracy. Write the averaged value of the conversion data to the offset registers.

To gain calibrate using a full scale calibration voltage, temporarily reduce the full scale register 95% to avoid output clipped codes (set FSCAL[2:0] to 3CCCCCh). Acquire n number of conversions and average the conversions to reduce noise to improve calibration accuracy. Compute the full-scale calibration value as shown in 公式 7:

$$\text{Full-Scale Calibration Value} = \text{Expected Code} / \text{Actual Code} \cdot 400000\text{h}$$

where

- Expected code = 799998h using full scale calibration signal and 95% scale factor (7)

## 9.5 Programming

### 9.5.1 Serial Interface

The serial interface is SPI-compatible and is used to read conversion data, configure registers, and control the ADC. The serial interface consists of four control lines:  $\overline{\text{CS}}$ , SCLK, DIN, and DOUT/DRDY. Most microcontroller SPI peripherals can operate with the ADC. The interface operates in SPI mode 1, where CPOL = 0 and CPHA = 1. In SPI mode 1, SCLK idles low and data are updated or changed on SCLK rising edges; data are latched or read on SCLK falling edges. Timing details of the SPI protocol are found in [图 1](#) and [图 2](#).

#### 9.5.1.1 Chip Select ( $\overline{\text{CS}}$ )

$\overline{\text{CS}}$  is an active-low input that selects the serial interface for communication.  $\overline{\text{CS}}$  must be low during the entire data transaction. When  $\overline{\text{CS}}$  is taken high, the serial interface resets, SCLK input activity is ignored (blocking commands), and DOUT/DRDY enters the high-impedance state. The operation of DRDY is not effected by  $\overline{\text{CS}}$ . If the ADC is a single device connected to the serial bus,  $\overline{\text{CS}}$  can be tied low in order to reduce the serial interface to three lines.

#### 9.5.1.2 Serial Clock (SCLK)

SCLK is the serial clock input that shifts data into and out of the ADC. Output data are updated on the rising edge of SCLK and input data are latched on the falling edge of SCLK. Return SCLK low after the data operation is completed. SCLK is a Schmidt-triggered input designed to improve noise immunity. Even though SCLK is noise resistant, keep SCLK as noise-free as possible to avoid unintentional SCLK transitions. Avoid ringing and overshoot on the SCLK input. Place a series termination resistor close to the SCLK drive pin to reduce ringing.

#### 9.5.1.3 Data Input (DIN)

DIN is the serial data input to the ADC. DIN is used to input commands and register data to the ADC. Data are latched on the falling edge of SCLK.

#### 9.5.1.4 Data Output/Data Ready (DOUT/DRDY)

The DOUT/DRDY pin is a dual-function output. The functions of this pin are data output and data ready. The functionality changes automatically based on whether a read data operation is in progress. During a read data operation, the functionality is data output. After the read operation is complete, the functionality changes to data ready.

In data output mode, data are updated on the SCLK rising edge, therefore the host latches the data on the falling edge of SCLK. In data-ready mode, the pin functions the same as DRDY (if  $\overline{\text{CS}}$  is low) by asserting low when data are ready. Therefore, monitor either DOUT/DRDY or DRDY to determine when data are ready. When  $\overline{\text{CS}}$  is high, the DOUT/DRDY pin is in the high-impedance mode (tri-state).

#### 9.5.1.5 Serial Interface Auto-Reset

The serial interface is reset by taking  $\overline{\text{CS}}$  high. Applications that tie  $\overline{\text{CS}}$  low do not have the ability to reset the serial interface by  $\overline{\text{CS}}$ . If a false SCLK occurs (for example, caused by a noise pulse or clocking glitch), the serial interface may inadvertently advance one or more bit positions, resulting in loss of synchronization to the host. If loss of synchronization occurs, the ADC interface does not respond correctly until the interface is reset.

For applications that tie  $\overline{\text{CS}}$  low, the serial interface auto-reset feature recovers the interface in the event that an unintentional SCLK glitch occurs. When the first SCLK low-to-high transition occurs (either caused by a glitch or by normal SCLK activity), seven SCLK transitions must occur within  $65536 f_{\text{CLK}}$  cycles (8.9 ms) to complete the byte transaction, otherwise the serial interface resets. After reset, the interface is ready to begin the next byte transaction. If the byte transaction is completed within the  $65536 f_{\text{CLK}}$  cycles, the serial interface does not reset. The cycle of SCLK detection re-starts at the next rising edge of SCLK. The serial interface is reset by holding SCLK low for a minimum  $65536 f_{\text{CLK}}$  cycles.

The auto-reset function is enabled by the SPITIM bit (default is off). See [图 3](#) for timing details.

## Programming (接下页)

### 9.5.2 Data Ready ( $\overline{\text{DRDY}}$ )

$\overline{\text{DRDY}}$  is an output that asserts low when conversion data are ready. After power-up,  $\overline{\text{DRDY}}$  also indicates when the ADC is ready for communication. The operation of  $\overline{\text{DRDY}}$  depends on the conversion mode (continuous or pulse) and whether the conversion data are retrieved or not. 图 75 shows  $\overline{\text{DRDY}}$  operation with and without data retrieval in the two modes of conversion.



图 75.  $\overline{\text{DRDY}}$  Operation

#### 9.5.2.1 $\overline{\text{DRDY}}$ in Continuous-Conversion Mode

In continuous-conversion mode,  $\overline{\text{DRDY}}$  is driven high when conversions are started and is driven low when conversion data are ready. During data readback,  $\overline{\text{DRDY}}$  returns high at the end of the read operation. If the conversion data are not read,  $\overline{\text{DRDY}}$  pulses high 16  $f_{\text{CLK}}$  cycles prior to the next falling edge.

To read conversion data before the next conversion is ready, send the complete read-data command 16  $f_{\text{CLK}}$  cycles before the next  $\overline{\text{DRDY}}$  falling edge. If the readback command is sent less than 16  $f_{\text{CLK}}$  cycles before the  $\overline{\text{DRDY}}$  falling edge, either old or new conversion data are provided, depending on the timing of when the command is sent. In the case that old conversion data are provided,  $\overline{\text{DRDY}}$  driven low is delayed until after the read data operation is completed. In this case, the  $\overline{\text{DRDY}}$  bit of the STATUS byte is cleared to indicate the same data have been read. If new conversion data are provided,  $\overline{\text{DRDY}}$  transitions low at the normal period of the data rate. In this case, the  $\overline{\text{DRDY}}$  bit of the STATUS byte is set to indicate that new data have been read. To make sure new data are read back, wait until  $\overline{\text{DRDY}}$  asserts low before starting the data read operation.

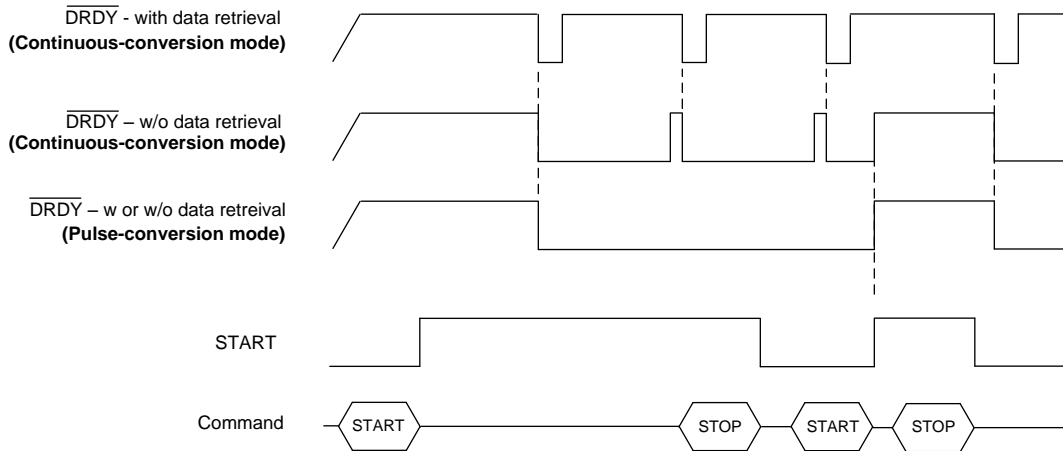
#### 9.5.2.2 $\overline{\text{DRDY}}$ in Pulse-Conversion Mode

$\overline{\text{DRDY}}$  is driven high at conversion start and is driven low when the conversion data are ready. During the data read operation  $\overline{\text{DRDY}}$  remains low until a new conversion is started.

#### 9.5.2.3 Data Ready by Software Polling

Use software polling of data ready in lieu of hardware polling of  $\overline{\text{DRDY}}$  or  $\text{DOUT}/\overline{\text{DRDY}}$ . To software poll, read the STATUS register and poll the  $\overline{\text{DRDY}}$  bit. In order to not skip conversion data in continuous conversion mode, poll the bit at least as often as the period of the data rate. If the  $\overline{\text{DRDY}}$  bit is set, then conversion data are new since the previous data read operation. If the bit is cleared, conversion data are not new since the previous data read operation. In this case, the previous conversion data are returned.

### 9.5.3 Conversion Data

Conversion data are read by the RDATA command. To read data, take  $\overline{\text{CS}}$  low and issue the read data command. The data field response consists of the optional STATUS byte, three data bytes, and the optional CRC byte. The CRC is computed over the combination of status byte and conversion data bytes. See the [RDATA Command](#) section for details to read conversion data.

## Programming (接下页)

### 9.5.3.1 Status byte (STATUS)

The status byte contains information on the operating state of the ADC. The STATUS byte is included with the conversion data by enabling bit STATENB of register MODE3. Optionally, read the STATUS register directly to read status information without the need to read conversion data. See [图 81](#) for details.

### 9.5.3.2 Conversion Data Format

The conversion data are 24 bits, in two's-complement format to represent positive and negative values. The data output begins with the most significant bit (sign bit) first. The data are scaled so that  $V_{IN} = 0$  V results in an uncalibrated code value of 000000h; positive full scale equals 7FFFFFFh and negative full scale equals 800000h; see [表 15](#) for the uncalibrated code values. The data are clipped to 7FFFFFFh (positive full scale) and 800000h (negative full scale) during positive and negative signal overdrive, respectively.

**表 15. ADC Conversion Data Codes**

DESCRIPTION	INPUT SIGNAL (V)	24-BIT CONVERSION DATA <sup>(1)</sup>
Positive full scale	$\geq V_{REF} / \text{Gain} \cdot (2^{23} - 1) / 2^{23}$	7FFFFFFh
1 LSB	$V_{REF} / (\text{Gain} \cdot 2^{23})$	000001h
Zero scale	0	000000h
-1 LSB	$-V_{REF} / (\text{Gain} \cdot 2^{23})$	FFFFFFh
Negative full scale	$\leq -V_{REF} / \text{Gain}$	800000h

(1) Ideal (calibrated) conversion data.

### 9.5.4 CRC

Cyclic redundancy check (CRC) is an error checking code that detects communication errors to and from the host. CRC is the division remainder of the data payload bytes by a fixed polynomial. The data payload is 1, 2, 3 or 4 bytes depending on the data operation. The CRC mode is optional and is enabled by the CRCENB bit. See [表 35](#) to program the CRC mode.

The user computes the CRC corresponding to the two command bytes and appends the CRC to the command string (3rd byte). A 4th, zero-value byte completes the command field. The ADC repeats the CRC calculation and compares the calculation to the received CRC. If the user and repeated CRC values match, the command executes and the ADC responds by transmitting the repeated CRC during the 4th byte of the command. If the operation is conversion data or register data read, the ADC responds with a 2nd CRC that is computed over the requested data payload bytes. The response data payload is 1, 3, or 4 bytes depending on the data operation.

If the user and repeated CRC values do not match, the command does not execute and the ADC responds with an inverted CRC for the actual received command bytes. The inverted CRC is intended to signal the host of the failed operation. The user terminates transmission of the command bytes to match the action of ADC termination. The CRCERR bit is set in the STATUS register when a CRC error is detected. The ADC is ready to accept the next command after a CRC error occurs at the end of the 4th byte.

The CRC data byte is the 8-bit remainder of the bitwise exclusive-OR (XOR) operation of the argument by a CRC polynomial. The CRC polynomial is based on the CRC-8-ATM (HEC):  $X^8 + X^2 + X^1 + 1$ . The nine binary polynomial coefficients are: 100000111. The CRC calculation is preset with "1" data values.

The CRC mnemonics apply to the following command sections.

- CRC-2: Input CRC of command bytes 1 and 2. Except for WREG command, the value of byte 2 is arbitrary
- Out CRC-1: Output CRC of one register data byte
- Out CRC-2: Output CRC of two command bytes, inverted value if input CRC error detected
- Out CRC-3: Output CRC of three conversion data bytes
- Out CRC-4: Output CRC of three conversion data bytes plus STATUS byte
- Echo Byte 1: Echo of received input byte 1
- Echo Byte 2: Echo of received input byte 2

## 9.5.5 Commands

Commands read conversion data, control the ADC, and read and write register data. See [表 16](#) for the list of commands. Send only the commands that are listed in [表 16](#). The ADC executes commands at completion of the 2nd byte (no CRC verification) or at completion of the 4th byte (with CRC verification). Follow the two byte or four byte format according to the CRC mode. Except for register write commands, the value of the second command byte is arbitrary but the value is included in the CRC calculation (total of two-byte CRC). If a CRC error is detected, the ADC does not execute the command. Taking  $\overline{CS}$  high before the command is completed results in termination of the command. When  $\overline{CS}$  is taken low, the communication frame is reset to start a new command.

**表 16. Command Byte Summary**

MNEMONIC	DESCRIPTION	BYTE 1	BYTE 2	BYTE 3 (CRC Mode Only)	BYTE 4 (CRC Mode only)
<b>Control Commands</b>					
NOP	No operation	00h	Arbitrary	CRC-2	00h
RESET	Reset	06h	Arbitrary	CRC-2	00h
START	Start conversion	08h	Arbitrary	CRC-2	00h
STOP	Stop conversion	0Ah	Arbitrary	CRC-2	00h
<b>Read Data Command</b>					
RDATA	Read conversion data	12h	Arbitrary	CRC-2	00h
<b>Calibration Commands</b>					
SYOCAL	System offset calibration	16h	Arbitrary	CRC-2	00h
GANCAL	Gain calibration	17h	Arbitrary	CRC-2	00h
SFOCAL	Self offset calibration	19h	Arbitrary	CRC-2	00h
<b>Register Commands</b>					
RREG	Read register data	20h + rrh <sup>(1)</sup>	Arbitrary	CRC-2	00h
WREG	Write register data	40h + rrh <sup>(1)</sup>	Register data	CRC-2	00h
<b>Protection Commands</b>					
LOCK	Register lock	F2h	Arbitrary	CRC-2	00h
UNLOCK	Register unlock	F5h	Arbitrary	CRC-2	00h

(1) rrh = 5-bit register address.

### 9.5.5.1 NOP Command

This command is no operation. Use the NOP command to validate the CRC response byte and error detection without affecting normal operation. [表 17](#) shows the NOP command byte sequence.

**表 17. NOP Command**

DIRECTION	BYTE 1	BYTE 2	BYTE 3	BYTE 4
<b>No CRC mode</b>				
DIN	00h	Arbitrary		
DOUT/ $\overline{DRDY}$	FFh	Echo byte 1		
<b>CRC mode</b>				
DIN	00h	Arbitrary	CRC-2	00h
DOUT/ $\overline{DRDY}$	FFh	Echo byte 1	Echo byte 2	Out CRC-2

### 9.5.5.2 RESET Command

The RESET command resets ADC operation and resets the registers to default values. See the [Reset by Command](#) section for details. [表 18](#) shows the RESET command byte sequence.

**表 18. RESET Command**

DIRECTION	BYTE 1	BYTE 2	BYTE 3	BYTE 4
<b>No CRC mode</b>				

**表 18. RESET Command (接下页)**

DIRECTION	BYTE 1	BYTE 2	BYTE 3	BYTE 4
DIN	06h	Arbitrary		
DOUT/ $\overline{\text{DRDY}}$	FFh	Echo byte 1		
<b>CRC mode</b>				
DIN	06h	Arbitrary	CRC-2	00H
DOUT/ $\overline{\text{DRDY}}$	FFh	Echo byte 1	Echo byte 2	Out CRC-2

### 9.5.5.3 START Command

This command starts conversions. See the [Conversion Control](#) section for details. 表 19 shows the START command byte sequence.

**表 19. START Command**

DIRECTION	BYTE 1	BYTE 2	BYTE 3	BYTE 4
<b>No CRC mode</b>				
DIN	08h	Arbitrary		
DOUT/ $\overline{\text{DRDY}}$	FFh	Echo byte 1		
<b>CRC mode</b>				
DIN	08h	Arbitrary	CRC-2	00h
DOUT/ $\overline{\text{DRDY}}$	FFh	Echo byte 1	Echo byte 2	Out CRC-2

### 9.5.5.4 STOP Command

This command stops conversions. See the [Conversion Control](#) section for details. 表 20 shows the STOP command byte sequence.

**表 20. STOP Command**

DIRECTION	BYTE 1	BYTE 2	BYTE 3	BYTE 4
<b>No CRC mode</b>				
DIN	0Ah	Arbitrary		
DOUT/ $\overline{\text{DRDY}}$	FFh	Echo byte 1		
<b>CRC mode</b>				
DIN	0Ah	Arbitrary	CRC-2	00h
DOUT/ $\overline{\text{DRDY}}$	FFh	Echo byte 1	Echo byte 2	Out CRC-2

### 9.5.5.5 RDATA Command

This command reads conversion data. Because the data are buffered, the data can be read at any time during the conversion phase. If data are read near the completion of the next conversion, old or new conversion data are returned. See the [Data Ready \( \$\overline{\text{DRDY}}\$ \)](#) section for details.

The response of conversion data varies in length from 3 to 5 bytes depending if the STATUS byte and CRC bytes are included. See the [Conversion Data Format](#) section for the numeric data format. See 表 21, 图 76 (minimum configuration) and 图 77 (maximum configuration) for operation of the RDATA command.

表 21. RDATA Command

DIRECTION	BYTE 1	BYTE 2	BYTE 3	BYTE 4	BYTE 5	BYTE 6	BYTE 7	BYTE 8	BYTE 9
<b>No CRC mode</b>									
DIN	12h	Arbitrary	00h	00h	00h	00h			
DOUT/DRDY	FFh	Echo byte 1	STATUS <sup>(1)</sup>	MSB data	MID data	LSB data			
<b>CRC mode</b>									
DIN	12h	Arbitrary	CRC-2	00h	00h	00h	00h	00h	00h
DOUT/DRDY	FFh	Echo byte 1	Echo byte 2	Out CRC-2	STATUS <sup>(1)</sup>	MSB data	MID data	LSB data	Out CRC-3 or Out CRC-4

(1) Optional STATUS byte.

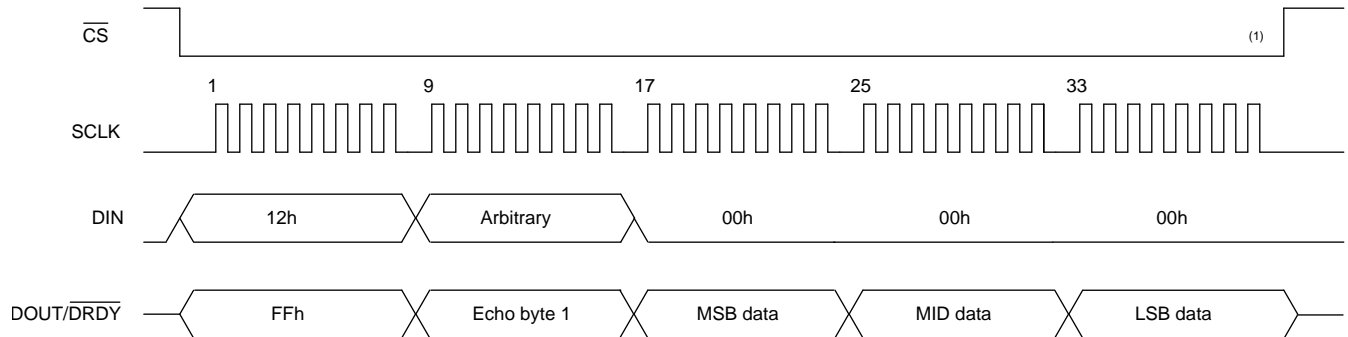

NOTE: CS can be tied low.

图 76. Conversion Data Read Operation (STATUS Byte and CRC Mode Disabled)

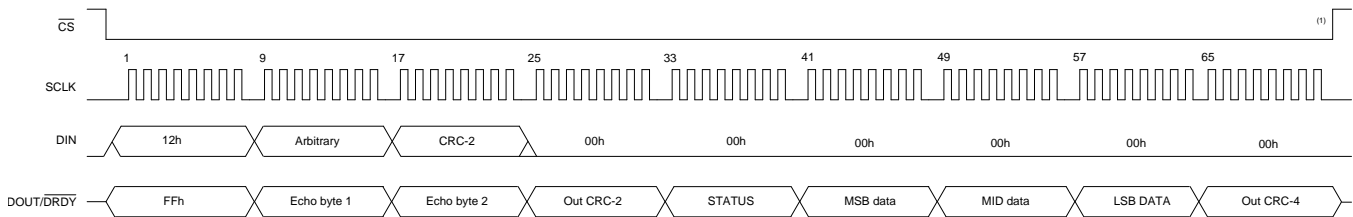

NOTE: CS can be tied low.

图 77. Conversion Data Read Operation (STATUS Byte and CRC Mode Enabled)

### 9.5.5.6 SYOCAL Command

This command is used for system offset calibration. See the [Offset System-Calibration \(SYOCAL\)](#) section for details. 表 22 shows the SYOCAL command byte sequence.

表 22. SYOCAL Command

DIRECTION	BYTE 1	BYTE 2	BYTE 3	BYTE 4
<b>No CRC mode</b>				
DIN	16h	Arbitrary		
DOUT/DRDY	FFh	Echo byte 1		
<b>CRC mode</b>				
DIN	16h	Arbitrary	CRC-2	00h
DOUT/DRDY	FFh	Echo byte 1	Echo Byte 2	Out CRC-2

### 9.5.5.7 GANCAL Command

This command is for gain calibration. See the [Full-Scale Calibration \(GANCAL\)](#) section for details. 表 23 shows the GANCAL command byte sequence.

表 23. GANCAL Command

DIRECTION	BYTE 1	BYTE 2	BYTE 3	BYTE 4
<b>No CRC mode</b>				
DIN	17h	Arbitrary		
DO $\overline{\text{UT}}$ /DRDY	FFh	Echo byte 1		
<b>CRC mode</b>				
DIN	17h	Arbitrary	CRC-2	00h
DO $\overline{\text{UT}}$ /DRDY	FFh	Echo byte 1	Echo Byte 2	Out CRC-2

### 9.5.5.8 SFOCAL Command

This command is used for *self* offset calibration. See the [Offset Self-Calibration \(SFOCAL\)](#) section for details. 表 24 shows the SFOCAL command byte sequence.

表 24. SFOCAL Command

DIRECTION	BYTE 1	BYTE 2	BYTE 3	BYTE 4
<b>No CRC mode</b>				
DIN	19h	Arbitrary		
DO $\overline{\text{UT}}$ /DRDY	FFh	Echo byte 1		
<b>CRC mode</b>				
DIN	19h	Arbitrary	CRC-2	00h
DO $\overline{\text{UT}}$ /DRDY	FFh	Echo byte 1	Echo Byte 2	Out CRC-2

### 9.5.5.9 RREG Command

Use the RREG command to read register data. The register data are read one byte at a time by issuing the RREG command for each operation. Add the register address (rrh) to the base opcode (20h) to construct the command byte (20h + rrh). 表 25 illustrates the command byte sequence. The ADC responds with the register data byte, most significant bit first. The response to registers outside the valid address range is 00h. 图 78 depicts an example of the register read operation. The Out CRC-1 byte is the CRC calculated for the register data byte.

表 25. RREG Command

DIRECTION	BYTE 1	BYTE 2	BYTE 3	BYTE 4	BYTE 5	BYTE 6
<b>No CRC mode</b>						
DIN	20h + rrh <sup>(1)</sup>	Arbitrary	00h			
DO $\overline{\text{UT}}$ /DRDY	FFh	Echo byte 1	Register data			
<b>CRC mode</b>						
DIN	20h + rrh	Arbitrary	CRC-2	00h	00h	00h
DO $\overline{\text{UT}}$ /DRDY	FFh	Echo byte 1	Echo byte 2	Out CRC-2	Register data	Out CRC-1

(1) rrh = 5-bit register address.

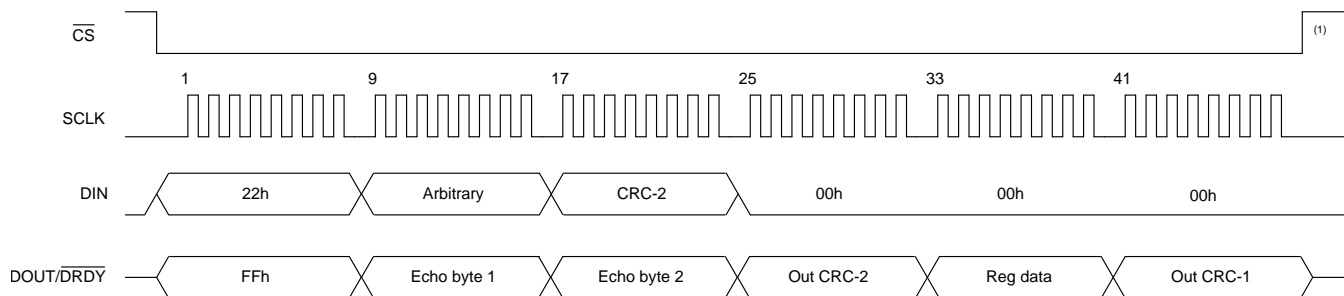

NOTE:  $\overline{CS}$  can be tied low.

图 78. Register Read Operation (address = 02h, CRC Mode Enabled)

9.5.5.10 WREG Command

Use the WREG command to write register data. The register data are written one byte at a time by issuing the WREG command for each operation. Add the register address (rrh) to the base opcode (40h) to construct the command byte (40h + rrh). 表 26 shows the command byte sequence. 图 79 shows an example of the WREG operation. Be aware that writing to certain registers results in conversion restart. 表 29 lists the registers that restart an ongoing conversion when written to. Do not write to registers outside the address range.

表 26. WREG Command

DIRECTION	BYTE 1	BYTE 2	BYTE 3	BYTE 4
<b>No CRC mode</b>				
DIN	40h + rrh <sup>(1)</sup>	Register data		
DOUT/DRDY	FFh	Echo byte 1		
<b>CRC mode</b>				
DIN	40h + rrh	Register data	CRC-2	00h
DOUT/DRDY	FFh	Echo byte 1	Echo byte 2	Out CRC-2

(1) rrh = 5-bit register address.

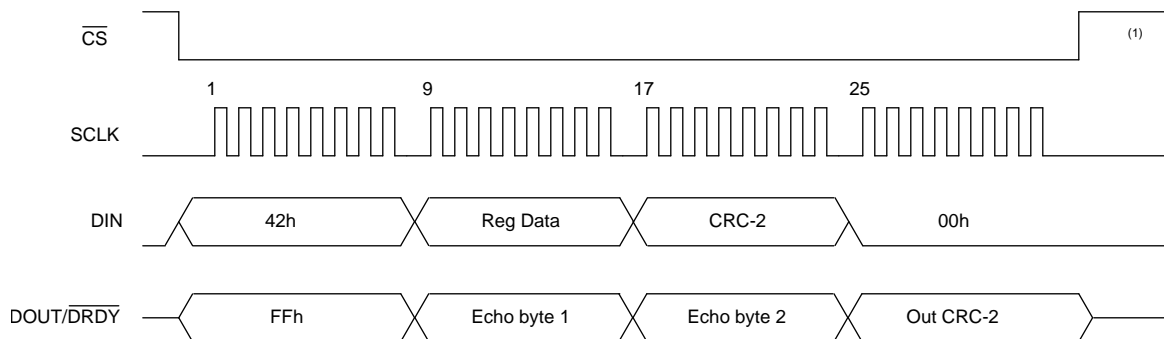

NOTE:  $\overline{CS}$  can be tied low.

图 79. Register Write Operation (address = 02h, CRC Mode Enabled)

### 9.5.5.11 LOCK Command

The LOCK command locks-out write access to the registers including the calibration registers that are changed by calibration commands. The default mode is UNLOCK. Read access is allowed in LOCK mode. 表 27 shows the LOCK command byte sequence.

**表 27. LOCK Command**

DIRECTION	BYTE 1	BYTE 2	BYTE 3	BYTE 4
<b>No CRC mode</b>				
DIN	F2h	Arbitrary		
DOUT/ $\overline{\text{DRDY}}$	FFh	Echo byte 1		
<b>CRC mode</b>				
DIN	F2h	Arbitrary	CRC-2	00h
DOUT/ $\overline{\text{DRDY}}$	FFh	Echo byte 1	Echo Byte2	out CRC-2

### 9.5.5.12 UNLOCK Command

The UNLOCK command allows register write access, including access to the contents of the calibration registers that can be changed by the calibration commands. 表 28 shows the UNLOCK command byte sequence.

**表 28. UNLOCK Command**

DIRECTION	BYTE 1	BYTE 2	BYTE 3	BYTE 4
<b>No CRC mode</b>				
DIN	F5h	Arbitrary		
DOUT/ $\overline{\text{DRDY}}$	FFh	Echo byte 1		
<b>CRC mode</b>				
DIN	F5h	Arbitrary	CRC-2	00h
DOUT/ $\overline{\text{DRDY}}$	FFh	Echo byte 1	Echo Byte2	Out CRC-2

## 9.6 Register Map

The register map consists of 19, one-byte registers. Collectively, the registers are used to configure the ADC to the desired operating mode. Access the registers by using the RREG and WREG (read-register and write-register) commands. Register data are accessed one register byte at a time for each command operation. At power-on or device reset, the registers are reset to the default values, as shown in the *Default* column of 表 29. Writing new data to certain registers causes the ADC conversion in progress to restart. These registers are listed in the *Restart* column in 表 29.

Register-write access is enabled or disabled by the UNLOCK and LOCK commands, respectively. The default mode is register UNLOCK. See the [LOCK Command](#) section for more details.

表 29. Register Map Summary

(rrh)	REGISTER	DEFAULT	RESTART	BIT 7	BIT 6	BIT 5	BIT 4	BIT 3	BIT 2	BIT 1	BIT 0
00h	ID	xxh		DEV_ID[3:0]				REV_ID[3:0]			
01h	STATUS	01h		LOCK	CRCERR	PGAL_ALM	PGAH_ALM	REFL_ALM	DRDY	CLOCK	RESET
02h	MODE0	24h	Yes	DR[4:0]				FILTER[2:0]			
03h	MODE1	01h	Yes	0	CHOP[1:0]		CONVRT	DELAY[3:0]			
04h	MODE2	00h		GPIO_CON[3:0]				GPIO_DIR[3:0]			
05h	MODE3	00h		PWDN	STATENB	CRCENB	SPITIM	GPIO_DAT[3:0]			
06h	REF	05h	Yes	0	0	0	REFENB	RMUXP[1:0]	RMUXN[1:0]		
07h	OFCAL0	00h		OFC[7:0]							
08h	OFCAL1	00h		OFC[15:8]							
09h	OFCAL2	00h		OFC[23:16]							
0Ah	FSCAL0	00h		FSC[7:0]							
0Bh	FSCAL1	00h		FSC[15:8]							
0Ch	FSCAL2	40h		FSC[23:16]							
0Dh	IMUX	FFh		IMUX2[3:0]				IMUX1[3:0]			
0Eh	IMAG	00h		IMAG2[3:0]				IMAG1[3:0]			
0Fh	RESERVED	00h		00h							
10h	PGA	00h	Yes	BYPASS	0	0	0	0	GAIN[2:0]		
11h	INPMUX	FFh	Yes	MUXP[3:0]				MUXN[3:0]			
12h	INPBIAS	00h	Yes	0	0	0	VBIAS	BOCSP	BOCS[2:0]		

### 9.6.1 Device Identification (ID) Register (address = 00h) [reset = xxh]

图 80. ID Register

7	6	5	4	3	2	1	0
DEV_ID[3:0]				REV_ID[3:0]			
NOTE: Reset values are device dependent							

LEGEND: R/W = Read/Write; R = Read only; -n = value after reset

表 30. ID Register Field Descriptions

Bit	Field	Type	Reset	Description
7:4	DEV_ID[3:0]	R	xh	<b>Device ID</b> 1000: ADS1261, ADS1261B 1010: ADS1260B
3:0	REV_ID[3:0]	R	xh	<b>Revision ID</b> <i>Note: Revision ID can change without notification</i>

**9.6.2 Device Status (STATUS) Register (address = 01h) [reset = 01h]**
**图 81. STATUS Register**

7	6	5	4	3	2	1	0
LOCK	CRCERR	PGAL_ALM	PGAH_ALM	REFL_ALM	DRDY	CLOCK	RESET
R-0h	R/W-0h	R-0h	R-0h	R-0h	R-0h	R-xh	R/W-1h

LEGEND: R/W = Read/Write; R = Read only; -n = value after reset

**表 31. STATUS Register Field Descriptions**

Bit	Field	Type	Reset	Description
7	LOCK	R	0h	<b>Register Lock Status</b> Indicates register lock status. Register writes are locked by the LOCK command and unlocked by the UNLOCK command. 0: Register write not locked (default) 1: Register write locked
6	CRCERR	R/W	0h	<b>CRC Error</b> Indicates that a CRC error is detected by the ADC. The CRC error bit remains set until cleared by the user. 0: No CRC error 1: CRC error
5	PGAL_ALM	R	0h	<b>PGA Low Alarm</b> Indicates PGA output voltage is below the low limit. The alarm resets at the start of conversion cycles. 0: No Alarm 1: Alarm
4	PGAH_ALM	R	0h	<b>PGA High Alarm</b> Indicates PGA output voltage is above the high limit. The alarm resets at the start of conversion cycles. 0: No Alarm 1: Alarm
3	REFL_ALM	R	0h	<b>Reference Low Alarm</b> Indicates reference voltage is below the low limit. The alarm resets at the start of conversion cycles. 0: No Alarm 1: Alarm
2	DRDY	R	0h	<b>Data Ready</b> Indicates conversion data ready. 0: Conversion data <b>not new</b> since the previous read operation 1: Conversion data <b>new</b> since the previous read operation
1	CLOCK	R	xh	<b>Clock</b> Indicates internal or external clock mode. The ADC automatically selects the clock source. 0: ADC clock is internal 1: ADC clock is external
0	RESET	R/W	1h	<b>Reset</b> Indicates ADC reset. Clear the bit to detect next device reset. 0: No reset 1: Reset (default)

**9.6.3 Mode 0 (MODE0) Register (address = 02h) [reset = 24h]**
**图 82. MODE0 Register**

7	6	5	4	3	2	1	0
DR[4:0]				FILTER[2:0]			
R/W-4h				R/W-4h			

LEGEND: R/W = Read/Write; R = Read only; -n = value after reset

**表 32. MODE0 Register Field Descriptions**

Bit	Field	Type	Reset	Description
7:3	DR[4:0]	R/W	4h	<b>Data Rate</b> Select the ADC data rate. 00000: 2.5 SPS 00001: 5 SPS 00010: 10 SPS 00011: 16.6̄ SPS 00100: 20 SPS (default) 00101: 50 SPS 00110: 60 SPS 00111: 100 SPS 01000: 400 SPS 01001: 1200 SPS 01010: 2400 SPS 01011: 4800 SPS 01100: 7200 SPS 01101: 14400 SPS 01110: 19200 SPS 01111: 25600 SPS 10000 - 11111: 40000 SPS (f <sub>CLK</sub> = 10.24 MHz)
2:0	FILTER[2:0]	R/W	4h	<b>Digital Filter</b> Select the digital filter mode. 000: sinc1 001: sinc2 010: sinc3 011: sinc4 100: FIR (default) 101: Reserved 110: Reserved 111: Reserved

9.6.4 Mode 1 (MODE1) Register (address = 03h) [reset = 01h]

图 83. MODE1 Register

7	6	5	4	3	2	1	0
0	CHOP[1:0]		CONVRT	DELAY[3:0]			
R/W-0h	R/W-0h		R/W-0h	R/W-1h			

LEGEND: R/W = Read/Write; R = Read only; -n = value after reset

表 33. MODE1 Register Field Descriptions

Bit	Field	Type	Reset	Description
7	0	R/W	0h	<b>Reserved</b> Always write 0
6:5	CHOP[1:0]	R/W	0h	<b>Chop and AC-Excitation Modes</b> Select the Chop and AC-excitation modes. 00: Normal mode (default) 01: Chop mode 10: 2-wire AC-excitation mode ( ADS1261 only) 11: 4-wire AC-excitation mode ( ADS1261 only)
4	CONVRT	R/W	0h	<b>ADC Conversion Mode</b> Select the ADC conversion mode. 0: Continuous conversions (default) 1: Pulse (one shot) conversion
3:0	DELAY[3:0]	R/W	1h	<b>Conversion Start Delay</b> Program the time delay at conversion start. Delay values are with $f_{CLK} = 7.3728$ MHz. 0000: 0 $\mu$ s (not for 25600 SPS or 40000 SPS operation) 0001: 50 $\mu$ s (default) 0010: 59 $\mu$ s 0011: 67 $\mu$ s 0100: 85 $\mu$ s 0101: 119 $\mu$ s 0110: 189 $\mu$ s 0111: 328 $\mu$ s 1000: 605 $\mu$ s 1001: 1.16 ms 1010: 2.27 ms 1011: 4.49 ms 1100: 8.93 ms 1101: 17.8 ms 1110: Reserved 1111: Reserved

**9.6.5 Mode 2 (MODE2) Register (address = 04h) [reset = 00h]**
**图 84. MODE2 Register**

7	6	5	4	3	2	1	0
GPIO_CON[3:0]				GPIO_DIR[3:0]			
R/W-0h				R/W-0h			

LEGEND: R/W = Read/Write; R = Read only; -n = value after reset

**表 34. MODE2 Register Field Descriptions<sup>(1)</sup>**

Bit	Field	Type	Reset	Description
7	GPIO_CON[3]	R/W	0h	<b>GPIO3 Pin Connection</b> Connect GPIO3 to analog input AIN5. 0: GPIO3 not connected to AIN5 (default) 1: GPIO3 connected to AIN5
6	GPIO_CON[2]	R/W	0h	<b>GPIO2 Pin Connection</b> Connect GPIO2 to analog input AIN4. 0: GPIO2 not connected to AIN4 (default) 1: GPIO2 connected to AIN4
5	GPIO_CON[1]	R/W	0h	<b>GPIO1 Pin Connection</b> Connect GPIO1 to analog input AIN3. 0: GPIO1 not connected to AIN3 (default) 1: GPIO1 connected to AIN3
4	GPIO_CON[0]	R/W	0h	<b>GPIO0 Pin Connection</b> Connect GPIO0 to analog input AIN2 0: GPIO0 not connected to AIN2 (default) 1: GPIO0 connected to AIN2
3	GPIO_DIR[3]	R/W	0h	<b>GPIO3 Pin Direction</b> Configure GPIO3 as a GPIO input or GPIO output on AIN5. 0: GPIO3 is an output (default) 1: GPIO3 is an input
2	GPIO_DIR[2]	R/W	0h	<b>GPIO2 Pin Direction</b> Configure GPIO2 as a GPIO input or GPIO output on AIN4. 0: GPIO2 is an output (default) 1: GPIO2 is an input
1	GPIO_DIR[1]	R/W	0h	<b>GPIO1 Pin Direction</b> Configure GPIO1 as a GPIO input or GPIO output on AIN3. 0: GPIO1 is an output (default) 1: GPIO1 is an input
0	GPIO_DIR[0]	R/W	0h	<b>GPIO0 Pin Direction</b> Configure GPIO0 as a GPIO input or GPIO output on AIN2. 0: GPIO0 is an output (default) 1: GPIO0 is an input

(1) ADS1261 and ADS1261B only.

**9.6.6 Mode 3 (MODE3) Register (address = 05h) [reset = 00h]**
**图 85. MODE3 Register**

7	6	5	4	3	2	1	0
PWDN	STATENB	CRCENB	SPITIM	GPIO_DAT[3:0]			
R/W-0h	R/W-0h	R/W-0h	R/W-0h	R/W-0h			

LEGEND: R/W = Read/Write; R = Read only; -n = value after reset

**表 35. MODE3 Register Field Descriptions**

Bit	Field	Type	Reset	Description
7	PWDN	R/W	0h	<b>Software Power-down Mode</b> Select the software power-down mode. 0: Normal mode (default) 1: Software power-down mode
6	STATENB	R/W	0h	<b>STATUS Byte</b> Enable the Status byte for the conversion data read operation. 0: No Status byte (default) 1: Status byte enabled
5	CRCENB	R/W	0h	<b>CRC Data Verification</b> Enable CRC data verification. 0: No CRC (default) 1: CRC enabled
4	SPITIM	R/W	0h	<b>SPI Auto-Reset Function</b> Enable the SPI auto-reset function. 0: SPI auto-reset disabled (default) 1: SPI auto-reset enabled
3	GPIO_DAT[3] <sup>(1)</sup>	R/W	0h	<b>GPIO3 Data</b> Read or write the GPIO3 data on AIN5. 0: GPIO3 is low (default) 1: GPIO3 is high
2	GPIO_DAT[2] <sup>(1)</sup>	R/W	0h	<b>GPIO2 Data</b> Read or write the GPIO2 data on AIN4. 0: GPIO2 is low (default) 1: GPIO2 is high
1	GPIO_DAT[1] <sup>(1)</sup>	R/W	0h	<b>GPIO1 Data</b> Read or write the GPIO1 data on AIN3. 0: GPIO1 is low (default) 1: GPIO1 is high
0	GPIO_DAT[0] <sup>(1)</sup>	R/W	0h	<b>GPIO0 Data</b> Read or write the GPIO1 data on AIN3. 0: GPIO0 is low (default) 1: GPIO0 is high

(1) ADS1261 and ADS1261B only.

**9.6.7 Reference Configuration (REF) Register (address = 06h) [reset = 05h]**
**图 86. REF Register**

7	6	5	4	3	2	1	0
0	0	0	REFENB	RMUXP[1:0]		RMUXN[1:0]	
R/W-0h	R/W-0h	R/W-0h	R/W-0h	R/W-1h		R/W-1h	

LEGEND: R/W = Read/Write; R = Read only; -n = value after reset

**表 36. REF Register Field Descriptions**

Bit	Field	Type	Reset	Description
7:5	0	R/W	0h	<b>Reserved</b> Always write 0h
4	REFENB	R/W	0h	<b>Internal Reference Enable</b> Enable the internal reference. 0: Internal reference disabled (default) 1: Internal reference enabled
3:2	RMUXP[1:0]	R/W	1h	<b>Reference Positive Input</b> Select the positive reference input. 00: Internal reference positive 01: AVDD internal (default) 10: AIN0 external 11: AIN2 external ( ADS1261 only)
1:0	RMUXN[1:0]	R/W	1h	<b>Reference Negative Input</b> Select the negative reference input. 00: Internal reference negative 01: AVSS internal (default) 10: AIN1 external 11: AIN3 external ( ADS1261 only)

**9.6.8 Offset Calibration (OFCALx) Registers (address = 07h, 08h, 09h) [reset = 00h, 00h, 00h]**
**图 87. OFCAL0, OFCAL1, OFCAL2 Registers**

7	6	5	4	3	2	1	0
OFC[7:0]							
R/W-00h							
15	14	13	12	11	10	9	8
OFC[15:8]							
R/W-00h							
23	22	21	20	19	18	17	16
OFC[23:16]							
R/W-00h							

LEGEND: R/W = Read/Write; R = Read only; -n = value after reset

**表 37. OFCAL0, OFCAL1, OFCAL2 Registers Field Description**

Bit	Field	Type	Reset	Description
23:0	OFC[23:0]	R/W	000000h	<b>Offset Calibration</b> These three registers are the 24-bit offset calibration word. The offset calibration is two's complement format. The ADC subtracts the offset value from the conversion result before the full-scale operation.

**9.6.9 Full-Scale Calibration (FSCALx) Registers (address = 0Ah, 0Bh, 0Ch) [reset = 00h, 00h, 40h]**
**图 88. FSCAL0, FSCAL1, FSCAL2 Registers**

7	6	5	4	3	2	1	0
FSC[7:0]							
R/W-00h							
15	14	13	12	11	10	9	8
FSC[15:8]							
R/W-00h							
23	22	21	20	19	18	17	16
FSC[23:16]							
R/W-40h							

LEGEND: R/W = Read/Write; R = Read only; -n = value after reset

**表 38. FSCAL0, FSCAL1, FSCAL2 Registers Field Description**

Bit	Field	Type	Reset	Description
23:0	FSC[23:0]	R/W	400000h	<b>Full-Scale Calibration</b> These three registers are the 24-bit full scale calibration word. The full-scale calibration is straight binary format. The ADC divides the register value by 400000h then multiplies the result with the conversion data. The scaling operation occurs after the offset operation.

9.6.10 IDAC Multiplexer (IMUX) Register (address = 0Dh) [reset = FFh]

图 89. IMUX Register

7	6	5	4	3	2	1	0
IMUX2[3:0]				IMUX1[3:0]			
R/W-Fh				R/W-Fh			

LEGEND: R/W = Read/Write; R = Read only; -n = value after reset

表 39. IMUX Register Field Descriptions

Bit	Field	Type	Reset	Description
7:4	IMUX2[3:0]	R/W	Fh	<b>IDAC2 Output Multiplexer</b> Select the IDAC2 analog input pin connection. 0000: AIN0 0001: AIN1 0010: AIN2 0011: AIN3 0100: AIN4 0101: AIN5 ( ADS1261 only) 0110: AIN6 ( ADS1261 only) 0111: AIN7 ( ADS1261 only) 1000: AIN8 ( ADS1261 only) 1001: AIN9 ( ADS1261 only) 1010: AINCOM 1011: No connection 1100: No connection 1101: No connection 1110: No connection 1111: No connection (default)
3:0	IMUX1[3:0]	R/W	Fh	<b>IDAC1 Output Multiplexer</b> Select the IDAC1 analog input pin connection. 0000: AIN0 0001: AIN1 0010: AIN2 0011: AIN3 0100: AIN4 0101: AIN5 ( ADS1261 only) 0110: AIN6 ( ADS1261 only) 0111: AIN7 ( ADS1261 only) 1000: AIN8 ( ADS1261 only) 1001: AIN9 ( ADS1261 only) 1010: AINCOM 1011: No connection 1100: No connection 1101: No connection 1110: No connection 1111: No connection (default)

9.6.11 IDAC Magnitude (IMAG) Register (address = 0Eh) [reset = 00h]

图 90. IMAG Register

7	6	5	4	3	2	1	0
IMAG2[3:0]				IMAG1[3:0]			
R/W-0h				R/W-0h			

LEGEND: R/W = Read/Write; R = Read only; -n = value after reset

表 40. IMAG Register Field Descriptions

Bit	Field	Type	Reset	Description
7:4	IMAG2[3:0]	R/W	0h	<b>IDAC2 Current Magnitude</b> Select the magnitude of current source IDAC2. 0000: Off (default) 0001: 50 $\mu$ A 0010: 100 $\mu$ A 0011: 250 $\mu$ A 0100: 500 $\mu$ A 0101: 750 $\mu$ A 0110: 1000 $\mu$ A 0111: 1500 $\mu$ A 1000: 2000 $\mu$ A 1001: 2500 $\mu$ A 1010: 3000 $\mu$ A 1011: Off 1100: Off 1101: Off 1110: Off 1111: Off
3:0	IMAG1[3:0]	R/W	0h	<b>IDAC1 Current Magnitude</b> Select the magnitude of current source IDAC1. 0000: Off (default) 0001: 50 $\mu$ A 0010: 100 $\mu$ A 0011: 250 $\mu$ A 0100: 500 $\mu$ A 0101: 750 $\mu$ A 0110: 1000 $\mu$ A 0111: 1500 $\mu$ A 1000: 2000 $\mu$ A 1001: 2500 $\mu$ A 1010: 3000 $\mu$ A 1011: Off 1100: Off 1101: Off 1110: Off 1111: Off

**9.6.12 Reserved (RESERVED) Register (address = 0Fh) [reset = 00h]**
**图 91. RESERVED Register**

7	6	5	4	3	2	1	0
0	0	0	0	0	0	0	0
R-0h	R-0h	R-0h	R-0h	R-0h	R-0h	R-0h	R-0h

LEGEND: R/W = Read/Write; R = Read only; -n = value after reset

**表 41. RESERVED Register Field Descriptions**

Bit	Field	Type	Reset	Description
7:0	0	R	0h	<b>Reserved</b> These bits are read only and always return 0

**9.6.13 PGA Configuration (PGA) Register (address = 10h) [reset = 00h]**
**图 92. PGA Register**

7	6	5	4	3	2	1	0
BYPASS	0	0	0	0	GAIN[2:0]		
R/W-0h	R/W-0h	R/W-0h	R/W-0h	R/W-0h	R/W-0h		

LEGEND: R/W = Read/Write; R = Read only; -n = value after reset

**表 42. PGA Register Field Descriptions**

Bit	Field	Type	Reset	Description
7	BYPASS	R/W	0h	<b>PGA Bypass Mode</b> Select the PGA mode. 0: PGA mode (default) 1: PGA bypass
6:3	0	R/W	0h	<b>Reserved</b> Always write 0
2:0	GAIN[2:0]	R/W	0h	<b>Gain</b> Select the gain. 000: 1 (default) 001: 2 010: 4 011: 8 100: 16 101: 32 110: 64 111: 128

9.6.14 Input Multiplexer (INPMUX) Register (address = 11h) [reset = FFh]

图 93. INPMUX Register

7	6	5	4	3	2	1	0
MUXP[3:0]				MUXN[3:0]			
R/W-Fh				R/W-Fh			

LEGEND: R/W = Read/Write; R = Read only; -n = value after reset

表 43. INPMUX Register Field Descriptions

Bit	Field	Type	Reset	Description
7:4	MUXP[3:0]	R/W	Fh	<p><b>Positive Input Multiplexer</b>                      Select the positive multiplexer input.</p> <ul style="list-style-type: none"> <li>0000: AINCOM</li> <li>0001: AIN0</li> <li>0010: AIN1</li> <li>0011: AIN2</li> <li>0100: AIN3</li> <li>0101: AIN4</li> <li>0110: AIN5 ( ADS1261 only)</li> <li>0111: AIN6 ( ADS1261 only)</li> <li>1000: AIN7 ( ADS1261 only)</li> <li>1001: AIN8 ( ADS1261 only)</li> <li>1010: AIN9 ( ADS1261 only)</li> <li>1011: Internal temperature sensor positive</li> <li>1100: Internal (AVDD - AVSS) / 4 positive</li> <li>1101: Internal (DVDD / 4) positive</li> <li>1110: Inputs open</li> <li>1111: Internal connection to V<sub>COM</sub> (default)</li> </ul>
3:0	MUXN[3:0]	R/W	Fh	<p><b>Negative Input Multiplexer</b>                      Select the negative multiplexer input.</p> <ul style="list-style-type: none"> <li>0000: AINCOM</li> <li>0001: AIN0</li> <li>0010: AIN1</li> <li>0011: AIN2</li> <li>0100: AIN3</li> <li>0101: AIN4</li> <li>0110: AIN5 ( ADS1261 only)</li> <li>0111: AIN6 ( ADS1261 only)</li> <li>1000: AIN7 ( ADS1261 only)</li> <li>1001: AIN8 ( ADS1261 only)</li> <li>1010: AIN9 ( ADS1261 only)</li> <li>1011: Internal temperature sensor negative</li> <li>1100: Internal (AVDD - AVSS) / 4 negative</li> <li>1101: Internal (DVDD / 4) negative</li> <li>1110: All inputs open</li> <li>1111: Internal connection to V<sub>COM</sub> (default)</li> </ul>

**9.6.15 Input Bias (INPBIAS) Register (address = 12h) [reset = 00h]**
**图 94. INPBIAS Register**

7	6	5	4	3	2	1	0
0	0	0	VBIAS	BOCSP	BOCS[2:0]		
R/W-0h	R/W-0h	R/W-0h	R/W-0h	R/W-0h	R/W-0h		

LEGEND: R/W = Read/Write; R = Read only; -n = value after reset

**表 44. INPBIAS Register Field Descriptions**

Bit	Field	Type	Reset	Description
7:5	0	R/W	0h	<b>Reserved</b> Always write 0
4	VBIAS	R/W	0h	<b>VBIAS</b> Select the VBIAS connection to the AINCOM pin. 0: VBIAS disabled (default) 1: VBIAS enabled
3	BOCSP	R/W	0h	<b>Burn-Out Current Source Polarity</b> Select the burn-out current source polarity. 0: Pull-up mode (default) 1: Pull-down mode
2:0	BOCS[2:0]	R/W	0h	<b>Burn-Out Current Source Magnitude</b> Select the burn-out current source magnitude. 000: Off (default) 001: 50 nA 010: 200 nA 011: 1 $\mu$ A 100: 10 $\mu$ A 101: Reserved 110: Reserved 111: Reserved

## 10 Application and Implementation

### 注

Information in the following applications sections is not part of the TI component specification, and TI does not warrant its accuracy or completeness. TI's customers are responsible for determining suitability of components for their purposes. Customers should validate and test their design implementation to confirm system functionality.

### 10.1 Application Information

#### 10.1.1 Input Range

In PGA mode, the input voltage must be within the specified input range for linear operation. The following exercise shows how to use [公式 5](#) to verify the input voltage is within specification. The exercise is a thermocouple with the negative lead connected to AINCOM and the level-shift voltage enabled (2.5 V). The gain factor = 32 and the ADC is powered by a single 5-V power supply. The summary of conditions are:

- $V_{AINN}$  = Negative absolute input voltage = 2.5 V
- $V_{AINP}$  = Positive absolute input voltage = 2.56 V
- $V_{IN}$  = Differential input voltage = 60 mV
- AVDD = 4.75 V (worst-case minimum)
- AVSS = 0 V
- Gain = 32

Evaluation of the equation results in:

$$1.23 \text{ V} < 2.5 \text{ V} \text{ and } 2.56 \text{ V} < 3.52 \text{ V}$$

The inequality is satisfied, therefore the absolute input voltages are within the specified PGA input range. The input requirement can also be verified by measuring the PGA output voltages (pins CAPP and CAPN) with a voltmeter. Check that both outputs are within the range:  $AVSS + 0.3 \text{ V} < V_{(CAPP)}$  and  $V_{(CAPN)} < AVDD - 0.3 \text{ V}$ , under the worst-case input and power-supply conditions.

#### 10.1.2 Input Overload

Observe the input overvoltage precautions as outlined in the [ESD Diodes](#) section. If an overvoltage condition occurs on an unused channel, the overvoltage channel may crosstalk to the measurement channel. One solution is to externally clamp the inputs with low-forward voltage diodes as shown in [图 95](#). The external diodes divert the overvoltage current around the ADC inputs to the power supply and ground. Be aware of the reverse leakage current of the Schottky diodes that may lead to measurement errors.

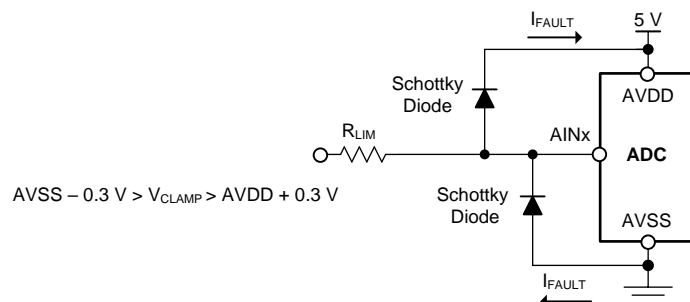

**图 95. External Diode Clamps**

## Application Information (接下页)

### 10.1.3 Burn-Out Current Source

When using the burn-out current sources, be aware of the offset error caused by the currents flowing through impedances in the input path, including the multiplexer resistance ( $R_{MUX}$ ), external filter resistors and the internal impedance of the sensor ( $R_{EXT}$ ), as shown in 图 96. In many cases, the offset error can be calibrated. Be aware that the combination of chop mode and high data rates increases the input current to the PGA. The increased input current can affect the accuracy of the burn-out current sources.



图 96. Burn-Out Current Source Offset Voltage Error

### 10.1.4 Unused Inputs and Outputs

- Analog inputs:  
To minimize input leakage of the measurement channel, tie unused inputs to mid-supply voltage ( $(AVDD + AVSS) / 2$ ) or to  $AVDD$ .
- Digital I/O:  
Not all the digital I/Os may be needed to operate the ADC. Be sure not to float both used and unused digital inputs, including during power-down mode. The following is a summary of the optional digital I/Os connection:
  - $\overline{CS}$ : Tie  $\overline{CS}$  low to permanently enable the serial interface.
  - $CLKIN$ : Tie  $CLKIN$  to  $DGND$  to permanently operate the ADC with the internal oscillator.
  - $START$ : Tie  $START$  to  $DGND$  to control conversions by command. Tie  $START$  to  $DVDD$  to permanently free-run conversions (Continuous-conversion mode only)
  - $RESET$ : Tie  $\overline{RESET}$  to  $DVDD$  if not using hardware reset. The ADC is reset at power-on. The ADC is also reset by the  $RESET$  command.
  - $PWDN$ : Tie  $\overline{PWDN}$  to  $DVDD$  if not using the hardware power-down mode. The ADC can be powered down by software.
  - $\overline{DRDY}$ : The functionality of the  $\overline{DRDY}$  output is also provided by the dual-mode  $DOUT/\overline{DRDY}$  pin. The  $DOUT/\overline{DRDY}$  output is active when  $\overline{CS}$  is low. Data ready is also determined by software polling. Because the conversion data are buffered, data can be read at any time without the need to synchronize to data ready.

## Application Information (接下页)

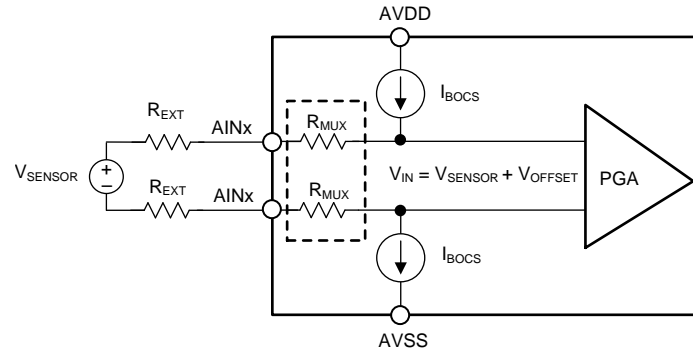
### 10.1.5 AC-Excitation

图 97 显示了一个 AC-激励桥测量系统的示例。该示例省略了可选的滤波元件，以便更清楚地说明。晶体管通过 GPIO 驱动器提供的驱动信号通过模拟输入引脚切换桥激励电压。驱动信号的时序与 ADC 转换同步。驱动信号不重叠，以避免在驱动信号切换期间发生桥切换。晶体管在电源上电时将电阻偏置晶体管关闭。在主机启动时，主机配置 ADC 为 AC-激励模式。请参阅图 7 了解驱动信号的时序。



图 97. 4-Wire Drive, AC-Excitation Example

The recommended sequence AC-excitation configuration is as follows:

1. Stop conversions by taking the START pin low, or by control of conversions in software mode; send the STOP command
2. Program the input and reference MUX, gain, data rate, filter mode and other configurations as needed
3. Program the 2-wire or 4-wire AC-excitation mode
4. Program the 2 GPIOs or 4 GPIOs internal connection to the analog input pins
5. Program the 2 GPIOs or 4 GPIOs as outputs to enable drive signals at the analog input pins.

Start the conversions. Adjust the time delay parameter as necessary based on the time constant of the input and reference filters.

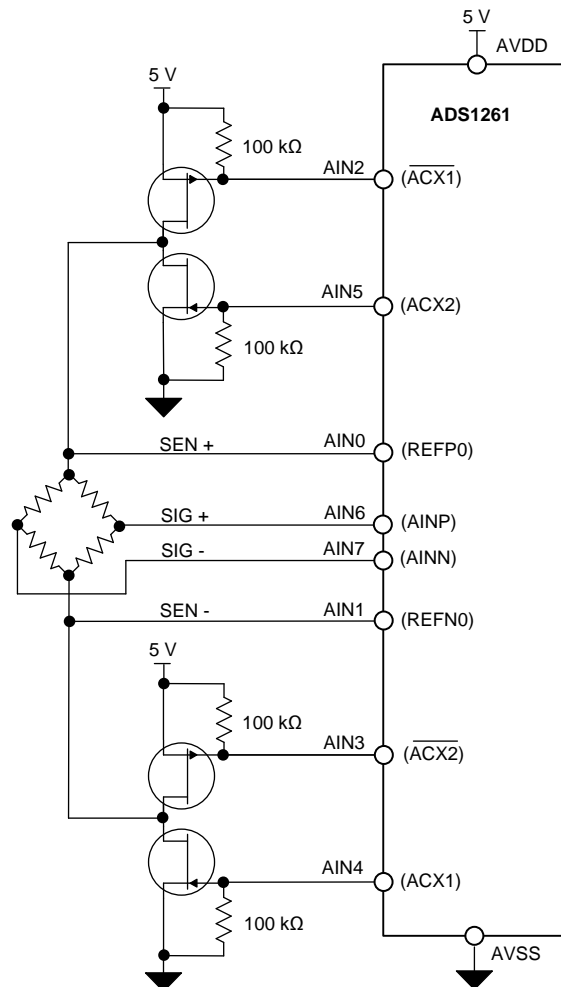
## Application Information (接下页)

### 10.1.6 Serial Interface and Digital Connections

图 98 显示了一个从主机  $\mu\text{C}$  到 ADC 的数字连接示例。并非所有 I/O 连接都是 ADC 基本操作所必需的；请参阅 [Unused Inputs and Outputs](#) 部分。与 I/O PCB 走线串联的阻抗匹配电阻有助于减少过冲和振铃，特别是在长走线运行时。



图 98. Serial Interface and Digital I/O Connections

## 10.2 Typical Application

图 99 shows a fault-protected, 3-wire RTD application with hardware-based, lead-wire compensation. Two current sources are used together to compensate the RTD lead wire resistance. One current source (IDAC1) provides excitation to the RTD element through  $R_{LEAD1}$ . The reference voltage of the ADC is derived directly from this current by resistor  $R_{REF}$ . The second current source cancels lead-wire resistance by generating a voltage drop on lead-wire resistance  $R_{LEAD2}$  equal to the voltage drop of  $R_{LEAD1}$ . Because the  $R_{RTD}$  signal voltage is measured differentially via inputs AIN2 and AIN3, the voltages across the lead wire resistance cancel. Resistor  $R_{BIAS}$  level-shifts the RTD signal voltage to within the ADC input range. The current sources route to the RTD element through low  $V_F$  diodes to provide input fault protection.

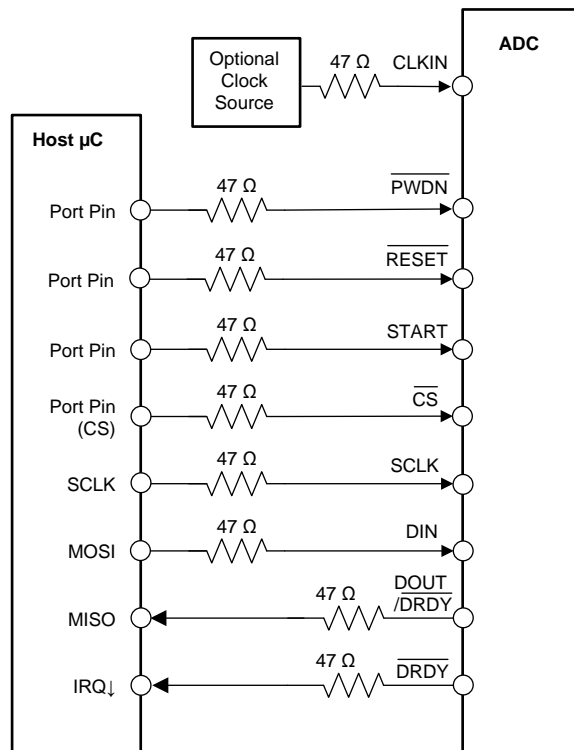

图 99. RTD Element With 3-Wire Lead Resistance Compensation

### 10.2.1 Design Requirements

The key considerations in the design of a 3-wire RTD circuit are the accuracy, stability and noise of the measurement, accuracy of the lead-wire compensation and self-heating of the sensor. Stability of the measurement is determined by the offset and gain drift of the ADC and by the drift of the external reference resistor. Measurement noise is determined by the ADC sample rate and by the digital filter settings. These parameters are not summarized here. 表 45 summarizes the basic design goals for a 3-wire Pt100 RTD.

表 45. Design Goals

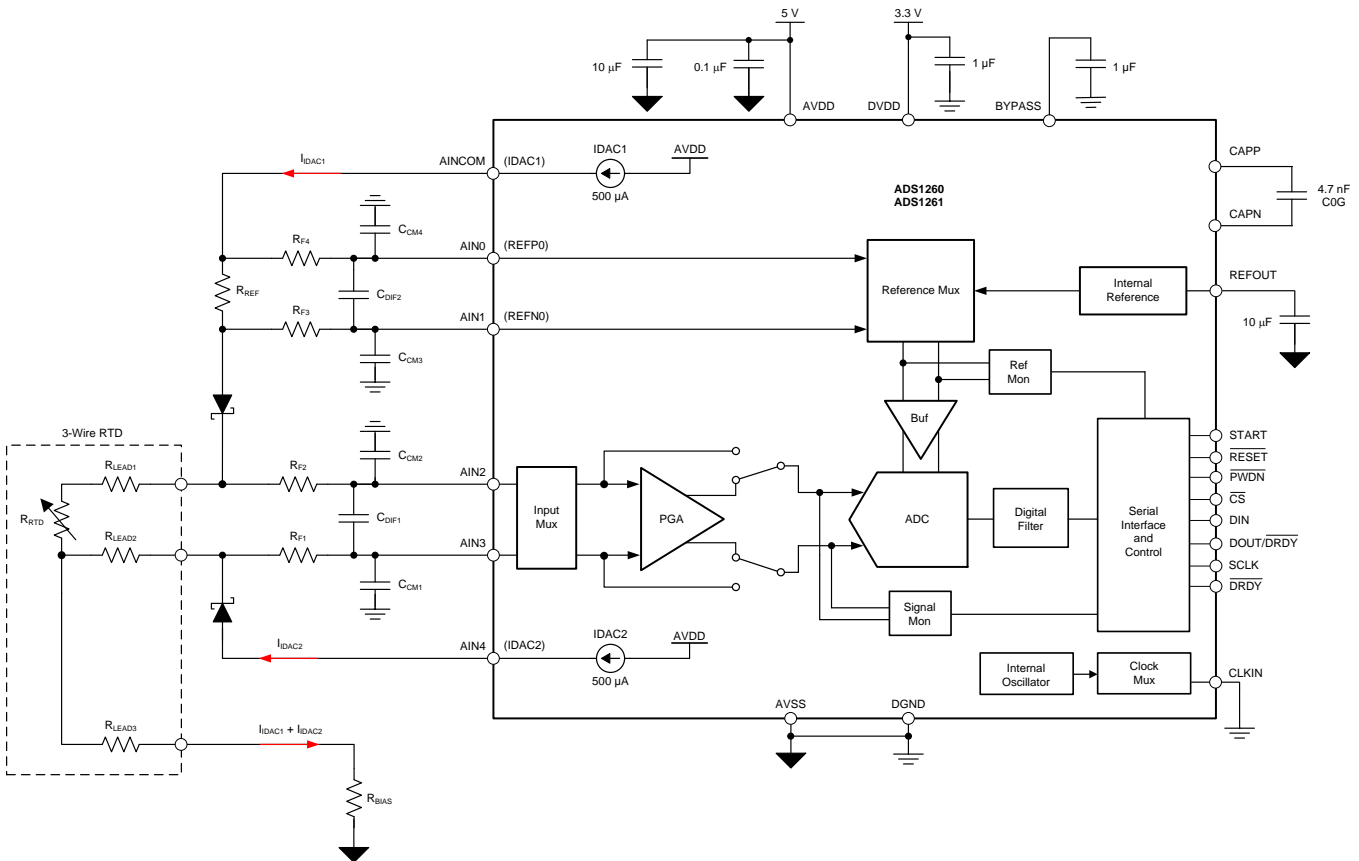
DESIGN PARAMETER	VALUE
RTD sensor type	3-wire Pt100
RTD resistance range	20 $\Omega$ to 400 $\Omega$
RTD lead resistance range	0 $\Omega$ to 10 $\Omega$
RTD self heating	< 1 mW

表 46 summarize the parameters of the detailed design procedure that follows.

**表 46. Design Parameters**

DESIGN PARAMETER		DESIGN VALUE
I <sub>IDAC</sub>	IDAC current	500 μA
P <sub>RTD</sub>	RTD power dissipation	0.1 mW
V <sub>RTD</sub>	RTD input voltage	0.20 V
Gain	ADC gain	8
V <sub>REF</sub>	Reference voltage (design target allows for 10% overrange)	1.76 V
R <sub>REF</sub>	Reference resistor (senses the IDAC current to generate V <sub>REF</sub> )	3.52 kΩ
R <sub>BIAS</sub>	Bias resistor (provides the RTD level-shift voltage)	1.10 kΩ
V <sub>RTDN</sub>	RTD negative input voltage	1.1 V
V <sub>RTDP</sub>	RTD positive input voltage	1.31 V
V <sub>IDAC1</sub>	IDAC1 loop voltage	3.37 V

### 10.2.2 Detailed Design Procedure

IDAC1 current flows through reference resistor, R<sub>REF</sub>, which generates the ADC reference voltage, V<sub>REF</sub> = I<sub>IDAC1</sub> · R<sub>REF</sub>. IDAC1 current also flows through the RTD element. Since the same current flows through R<sub>REF</sub> and the RTD element, the RTD measurement is ratiometric, which means the drift and error of the current source are cancelled. Therefore, the measurement accuracy is solely dependent on the tolerance of R<sub>REF</sub> and on ADC gain and offset errors. The errors are calibrated by host software control using shorted-input calibration and using a 400 Ω precision resistor for full-scale calibration.

The current of IDAC2 is programmed to the same value as IDAC1 and is connected to R<sub>LEAD2</sub>. IDAC2 generates an equal voltage drop across R<sub>LEAD1</sub> and IDAC1. The accuracy of lead-wire compensation depends on the matching error between IDAC1 to IDAC2.

Using R<sub>RTD</sub> = 400 Ω, IDAC current = 500 μA, and gain = 8, the minimum ADC reference voltage requirement calculates to 1.6 V. To provide 10% design margin, R<sub>REF</sub> calculates to 3.52 kΩ (1.76 V / 500 μA). 500 μA is selected to minimize heating of the sensor.

Resistor R<sub>BIAS</sub> level-shifts the RTD voltage to meet the input range requirement of the ADC. This voltage is V<sub>RTDN</sub> and the low limit is calculated by 公式 8. The V<sub>RTDN</sub> low limit is 1 V.

$$AVSS + 0.3 \text{ V} + V_{RTD} \cdot (\text{Gain} - 1) / 2 \leq V_{RTDN} \quad (8)$$

Using 10% design margin, R<sub>BIAS</sub> calculates to 1.1 kΩ = 1.1 V / (2 · 500 μA). The next step is to verify the positive RTD voltage (V<sub>RTDP</sub>) does not exceed the maximum input range, as shown in 公式 9:

$$\text{Maximum } V_{RTDP} \leq AVDD - 0.3 \text{ V} - V_{RTD} \cdot (\text{Gain} - 1) / 2 \quad (9)$$

Evaluation of the equation results in the V<sub>RTDP</sub> high limit = 3.75 V. Calculate the actual V<sub>RTDP</sub> input voltage by 公式 10:

$$\text{Actual } V_{RTDP} = V_{RTDN} + I_{IDAC1} \cdot (R_{RTD} + 2 \cdot R_{LEAD}) = 1.1 \text{ V} + 500 \mu\text{A} \cdot (400 \Omega + 20 \Omega) = 1.31 \text{ V} \quad (10)$$

V<sub>RTDN</sub> = 1.1 V and V<sub>RTDP</sub> = 1.31 V satisfy the negative and positive input voltage requirements of the ADC, respectively.

Verify the burden voltage of current source IDAC1 is below the specified compliance range. The burden voltage is the sum of voltages in the IDAC1 loop as calculated by V<sub>RTDP+</sub> (IDAC1 · R<sub>REF</sub>) + V<sub>D</sub> (V<sub>D</sub> = external diode voltage). The result is 3.37 V, which meets the specified compliance voltage of the current source.

External filter components R<sub>F1</sub>, R<sub>F2</sub>, C<sub>DIF1</sub>, C<sub>CM1</sub>, C<sub>CM2</sub>) and R<sub>F3</sub>, R<sub>F4</sub>, C<sub>DIF2</sub>, C<sub>CM3</sub>, and C<sub>CM4</sub>) filter the signal and reference inputs of the ADC. The filters remove both differential and common-mode noise. The input signal differential filter cutoff frequency as calculated by 公式 11:

$$f_{DIF} = 1 / [2\pi \cdot R_{F1} + R_{F2}) \cdot R_{DIF1} + C_{M1} || C_{M2}] \quad (11)$$

The Input signal common-mode filter is calculated by 公式 12:

$$f_{CM} = 1 / (2\pi \cdot R_{F1} \cdot C_{M1}) = 1 / (2\pi \cdot R_{F2} \cdot C_{M2}) \quad (12)$$

Component mismatch in the common-mode filter converts common-mode noise into differential noise. Use a differential capacitor  $C_{DIF1}$  10 $\times$  higher value than the common-mode capacitors,  $C_{CM1}$  and  $C_{CM2}$  to minimize the effects of mismatch. The recommended range of input resistors is 1 k $\Omega$  to 10 k $\Omega$ ; increasing the resistance beyond 10 k $\Omega$  beyond can compromise noise and drift performance of the ADC. Use high-quality COG ceramics or film-type capacitors. For consistent noise performance across the full RTD temperature range, match the corner frequencies of the input and reference filters. Detailed information is found in the [RTD Ratiometric Measurements and Filtering Using the ADS1148 and ADS1248 Family of Devices](#) application report.

### 10.2.3 Application Curves

图 100 shows the resistance measurement results. The measurements are taken at  $T_A = 25^\circ\text{C}$ . The data are taken using a precision resistor simulator with a 3-wire connection in place of the RTD. A system offset calibration is performed using shorted inputs. A system gain calibration is performed using a 390- $\Omega$  precision resistor. The measurement data are in ohms and do not include the error of the RTD sensor. The measured resistance error is  $< \pm 0.02 \Omega$  over the 20- $\Omega$  to 400- $\Omega$  range.



图 100. 3-Wire RTD Example Measurement Results

### 10.3 Initialization Setup

图 101 shows a general configuration and measurement procedure.

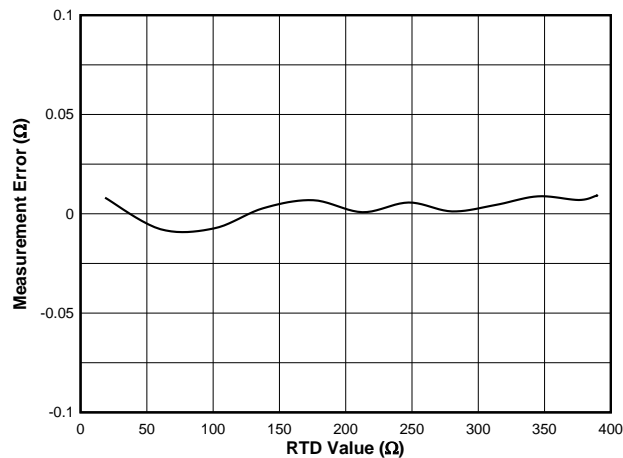

图 101. ADC Configuration and Measurement Procedure

## 11 Power Supply Recommendations

The ADC requires an analog power supply (AVDD, AVSS) and digital power supply (DVDD). The analog power supply can be bipolar (AVDD = +2.5 V and AVSS = -2.5 V) or unipolar (AVDD = 5 V and AVSS = DGND). The digital supply range is 2.7 V to 5.25 V. DVDD powers the ADC core by use of an internal regulator. DVDD also sets the digital I/O voltage. Keep in mind that the GPIO I/O voltages are AVDD and AVSS. Voltage ripple produced by switch-mode power supplies may interfere with the ADC conversions. Use low-dropout regulators (LDOs) to reduce switch-mode power supply ripple.

### 11.1 Power-Supply Decoupling

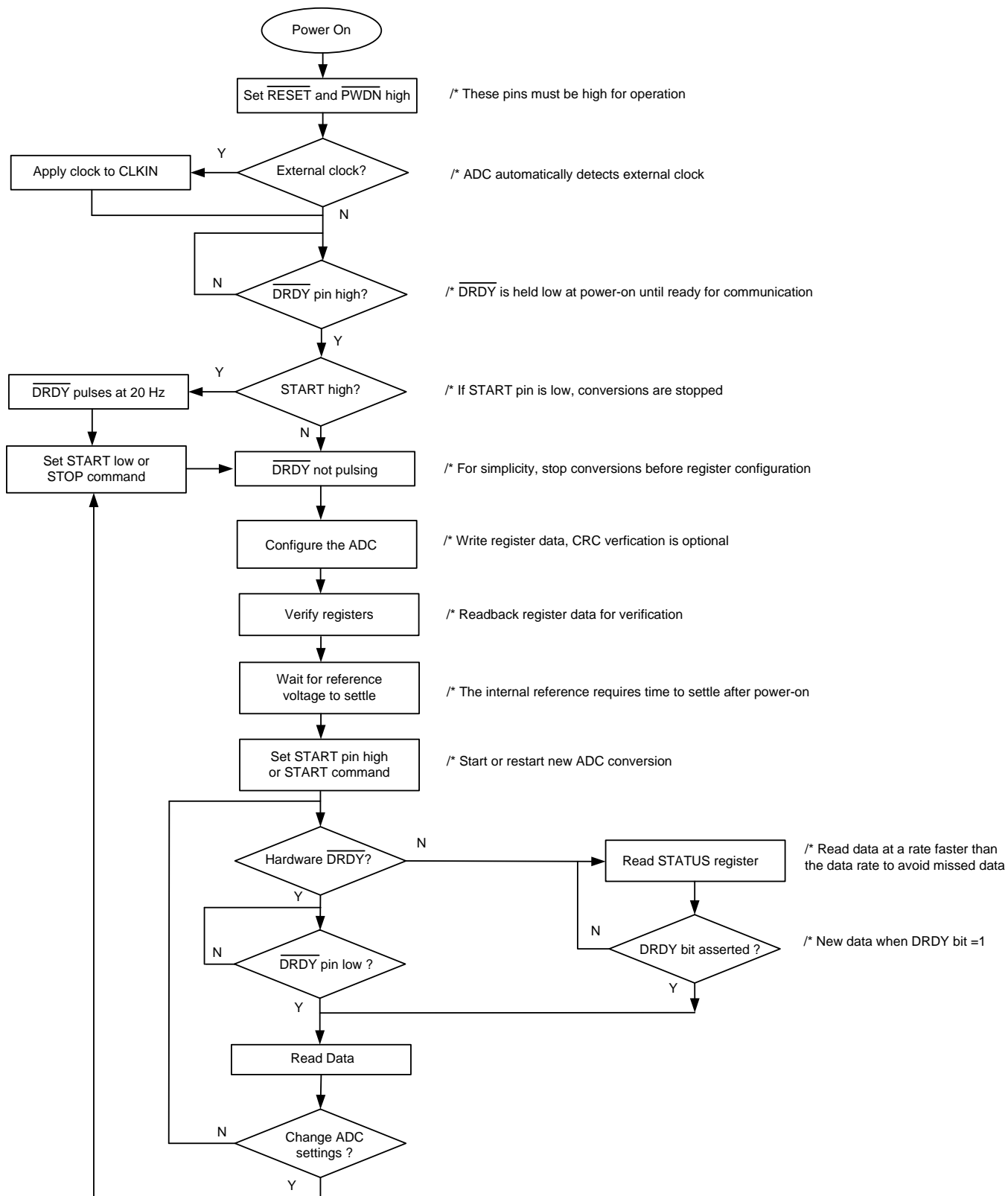
Good power-supply decoupling is important in order to achieve optimum performance. Power supplies must be decoupled close to the power supply pins using short, direct connections to ground. For the analog supply, place 0.1- $\mu$ F and 10- $\mu$ F capacitors between AVDD and AVSS and 0.1- $\mu$ F capacitors from each supply to ground. Connect a 1- $\mu$ F capacitor from DVDD to the ground plane. Connect a 1- $\mu$ F capacitor from BYPASS to the ground plane.

### 11.2 Analog Power-Supply Clamp

It is important to evaluate circumstances when an input signal is present with the ADC, both powered and unpowered. When the input signal exceeds the power-supply voltage, it is possible to *backdrive* the analog power-supply voltage with the input signal through a conduction path of the internal ESD diodes. Backdriving the ADC power supply can also occur when the power supply is on. The backdriven current path is illustrated in [Figure 102](#). Depending on how the power supply responds during a backdriven condition, it is possible to exceed the maximum rated ADC supply voltage. The ADC voltage must not be exceeded at all times. One solution is to clamp the analog supply to safe voltage using an external zener diode.

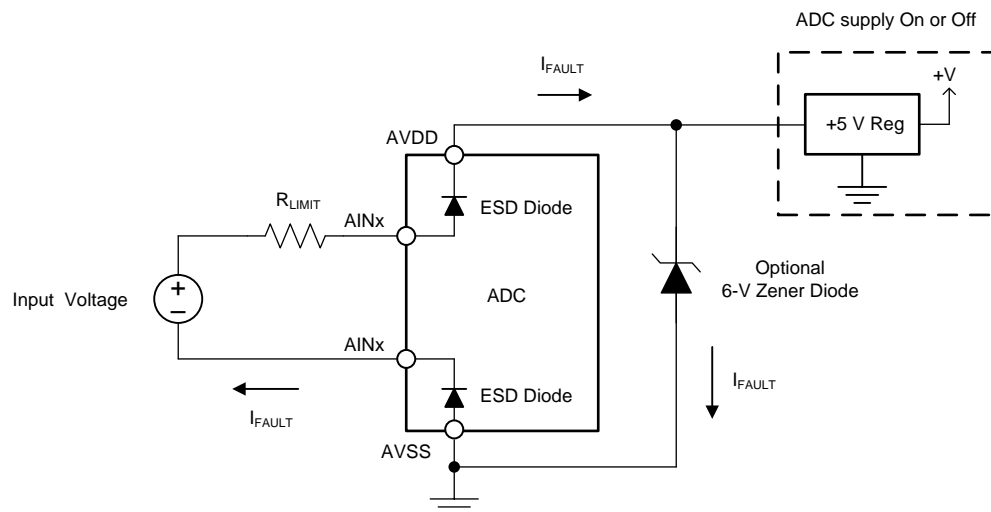

**图 102. Analog Power-Supply Clamp**

### 11.3 Power-Supply Sequencing

The power supplies can be sequenced in any order, but do not allow the analog or digital inputs to exceed the respective analog or digital power-supplies without external limits of the possible input fault currents.

## 12 Layout

Good layout practices are crucial to realize the full-performance of the ADC. Poor grounding can quickly degrade the noise performance. The following layout guidelines help provide the best results.

### 12.1 Layout Guidelines

For best performance, dedicate an entire PCB layer to a ground plane and do not route any other signal traces on this layer. However, depending on restrictions imposed by specific end equipment, a dedicated ground plane may not be practical. If ground plane separation is necessary, make a direct connection of the planes at the ADC. Do not connect individual ground planes at multiple locations because this configuration creates ground loops.

Route digital traces away from the CAPP and CAPN pins, away from the REFOUT pin, and away from all analog inputs and associated components in order to minimize interference.

Avoid long traces on DOUT/ $\overline{\text{DRDY}}$ , because high capacitance on this pin can lead to increase of ADC noise levels. Use a series resistor or a buffer if long traces are used.

The internal reference output return shares the same pin as the AVSS power supply. To minimize coupling between the power supply and reference-return trace, route the traces separately; ideally, as a star connection to the AVSS pin.

Use C0G capacitors on the analog inputs and for the CAPP to CAPN capacitor. Use ceramic capacitors (for example, X7R grade) for the power supply decoupling capacitors. High-K capacitors (Y5V) are not recommended. The REFOUT pin requires a 10- $\mu\text{F}$  capacitor and can be either ceramic or tantalum type. Place the required capacitors as close as possible to the device pins using short, direct traces. For optimum performance, use low-impedance connections on the ground-side connections of the bypass capacitors.

When applying an external clock, be sure the clock is free of overshoot and glitches. A source-termination resistor placed at the clock buffer often helps reduce overshoot. Glitches present on the clock input can lead to noise within the conversion data.

### 12.2 Layout Example

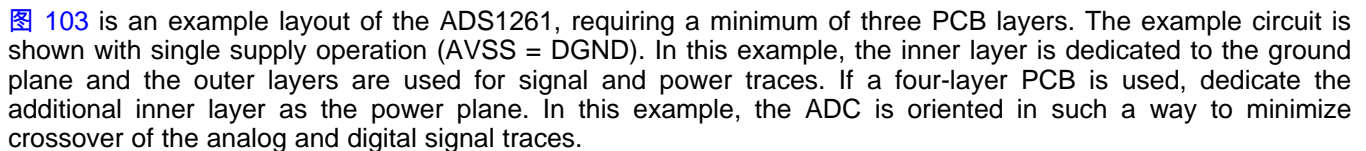
 **103** is an example layout of the ADS1261, requiring a minimum of three PCB layers. The example circuit is shown with single supply operation ( $\text{AVSS} = \text{DGND}$ ). In this example, the inner layer is dedicated to the ground plane and the outer layers are used for signal and power traces. If a four-layer PCB is used, dedicate the additional inner layer as the power plane. In this example, the ADC is oriented in such a way to minimize crossover of the analog and digital signal traces.

Layout Example (接下页)



图 103. ADS1261 Layout Example

## 13 器件和文档支持

### 13.1 文档支持

#### 13.1.1 相关文档

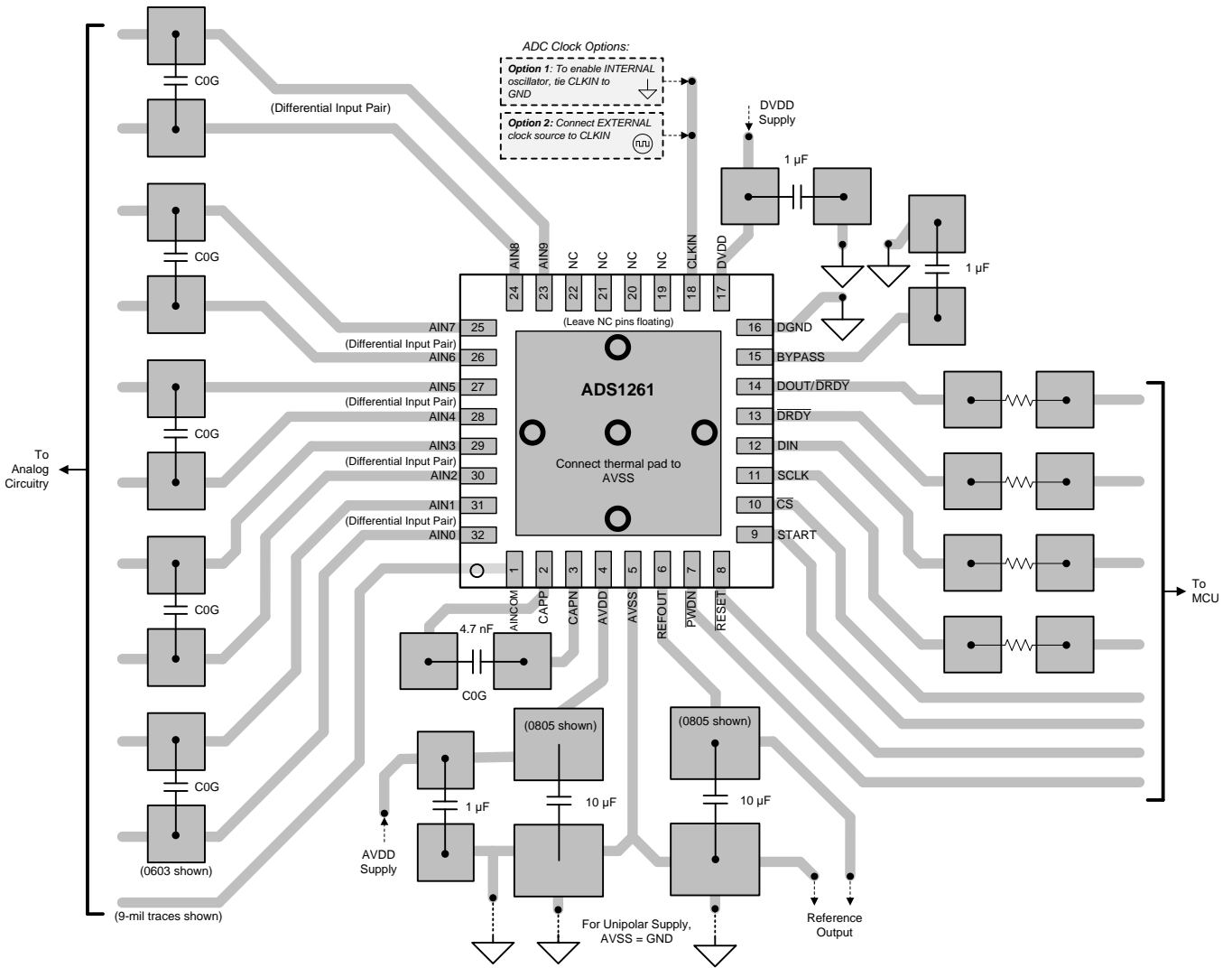
请参阅如下相关文档:

德州仪器 (TI), [ADS1261](#) 和 [ADS1235 评估模块用户指南](#)

### 13.2 相关链接

下表列出了快速访问链接。类别包括技术文档、支持和社区资源、工具和软件，以及立即订购快速访问。

表 47. 相关链接

器件	产品文件夹	立即订购	技术文档	工具与软件	支持和社区
ADS1260	<a href="#">请单击此处</a>	<a href="#">请单击此处</a>	<a href="#">请单击此处</a>	<a href="#">请单击此处</a>	<a href="#">请单击此处</a>
ADS1261	<a href="#">请单击此处</a>	<a href="#">请单击此处</a>	<a href="#">请单击此处</a>	<a href="#">请单击此处</a>	<a href="#">请单击此处</a>

### 13.3 接收文档更新通知

要接收文档更新通知，请导航至 [TI.com.cn](http://TI.com.cn) 上的器件产品文件夹。单击右上角的 [通知我](#) 进行注册，即可每周接收产品信息更改摘要。有关更改的详细信息，请查看任何已修订文档中包含的修订历史记录。

### 13.4 社区资源

下列链接提供到 TI 社区资源的连接。链接的内容由各个分销商“按照原样”提供。这些内容并不构成 TI 技术规范，并且不一定反映 TI 的观点；请参阅 TI 的 [《使用条款》](#)。

**TI E2E™ 在线社区** [TI 的工程师对工程师 \(E2E\) 社区](#)。此社区的创建目的在于促进工程师之间的协作。在 [e2e.ti.com](http://e2e.ti.com) 中，您可以咨询问题、分享知识、拓展思路并与同行工程师一道帮助解决问题。

**设计支持** [TI 参考设计支持](#) 可帮助您快速查找有帮助的 E2E 论坛、设计支持工具以及技术支持的联系信息。

### 13.5 商标

E2E is a trademark of Texas Instruments.

All other trademarks are the property of their respective owners.

### 13.6 静电放电警告



ESD 可能会损坏该集成电路。德州仪器 (TI) 建议通过适当的预防措施处理所有集成电路。如果不遵守正确的处理措施和安装程序，可能会损坏集成电路。

ESD 的损坏小至导致微小的性能降级，大至整个器件故障。精密的集成电路可能更容易受到损坏，这是因为非常细微的参数更改都可能导致器件与其发布的规格不相符。

### 13.7 术语表

[SLYZ022](#) — TI 术语表。

这份术语表列出并解释术语、缩写和定义。

## 14 机械、封装和可订购信息

以下页面包含机械、封装和可订购信息。这些信息是指定器件的最新可用数据。数据如有变更，恕不另行通知，且不会对此文档进行修订。如需获取此数据表的浏览器版本，请查阅左侧的导航栏。



**RHB0032E**

**PACKAGE OUTLINE**

**VQFN - 1 mm max height**

PLASTIC QUAD FLATPACK - NO LEAD

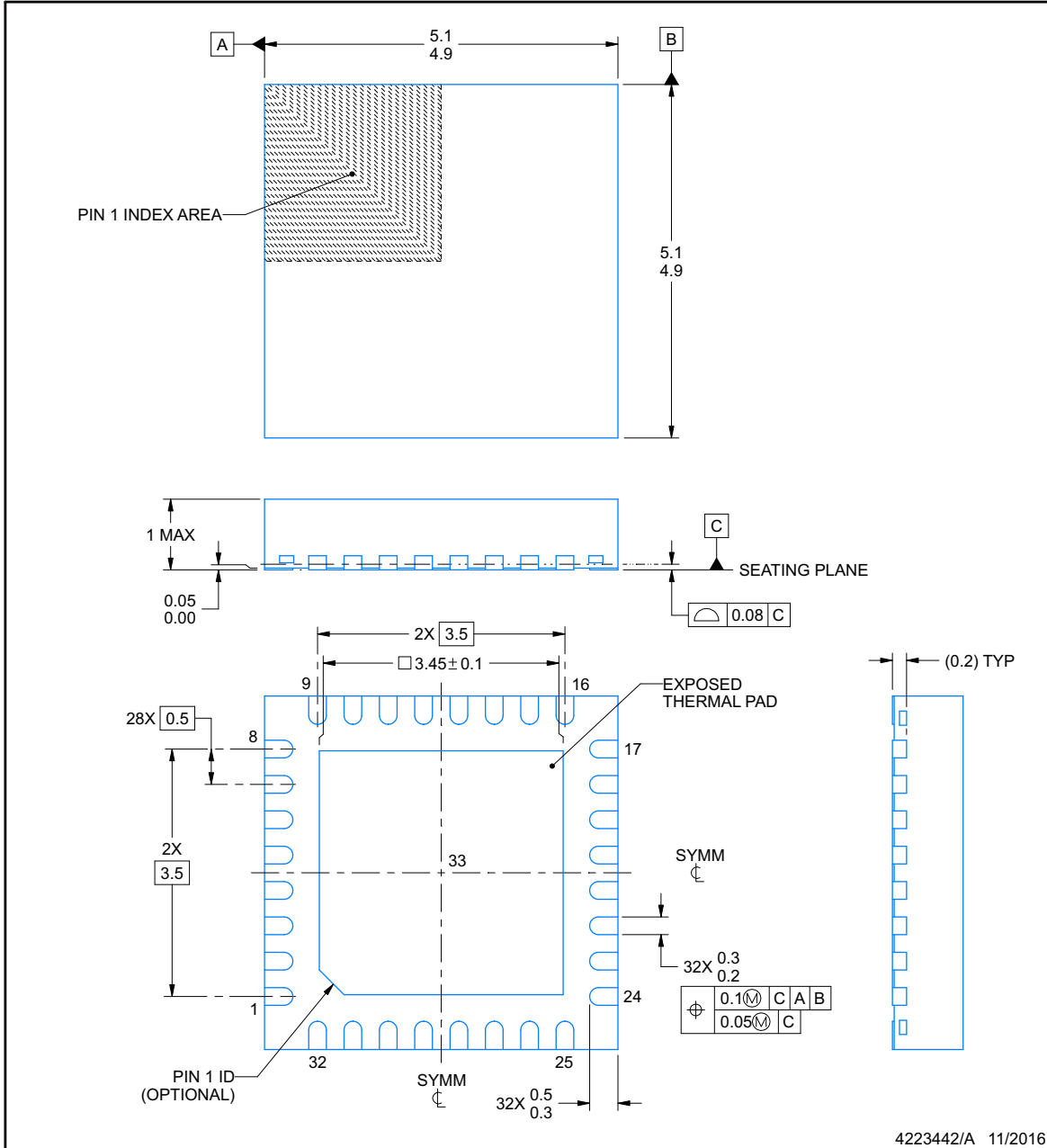

**NOTES:**

1. All linear dimensions are in millimeters. Any dimensions in parenthesis are for reference only. Dimensioning and tolerancing per ASME Y14.5M.
2. This drawing is subject to change without notice.
3. The package thermal pad must be soldered to the printed circuit board for thermal and mechanical performance.

**EXAMPLE BOARD LAYOUT**

**RHB0032E**

**VQFN - 1 mm max height**

PLASTIC QUAD FLATPACK - NO LEAD

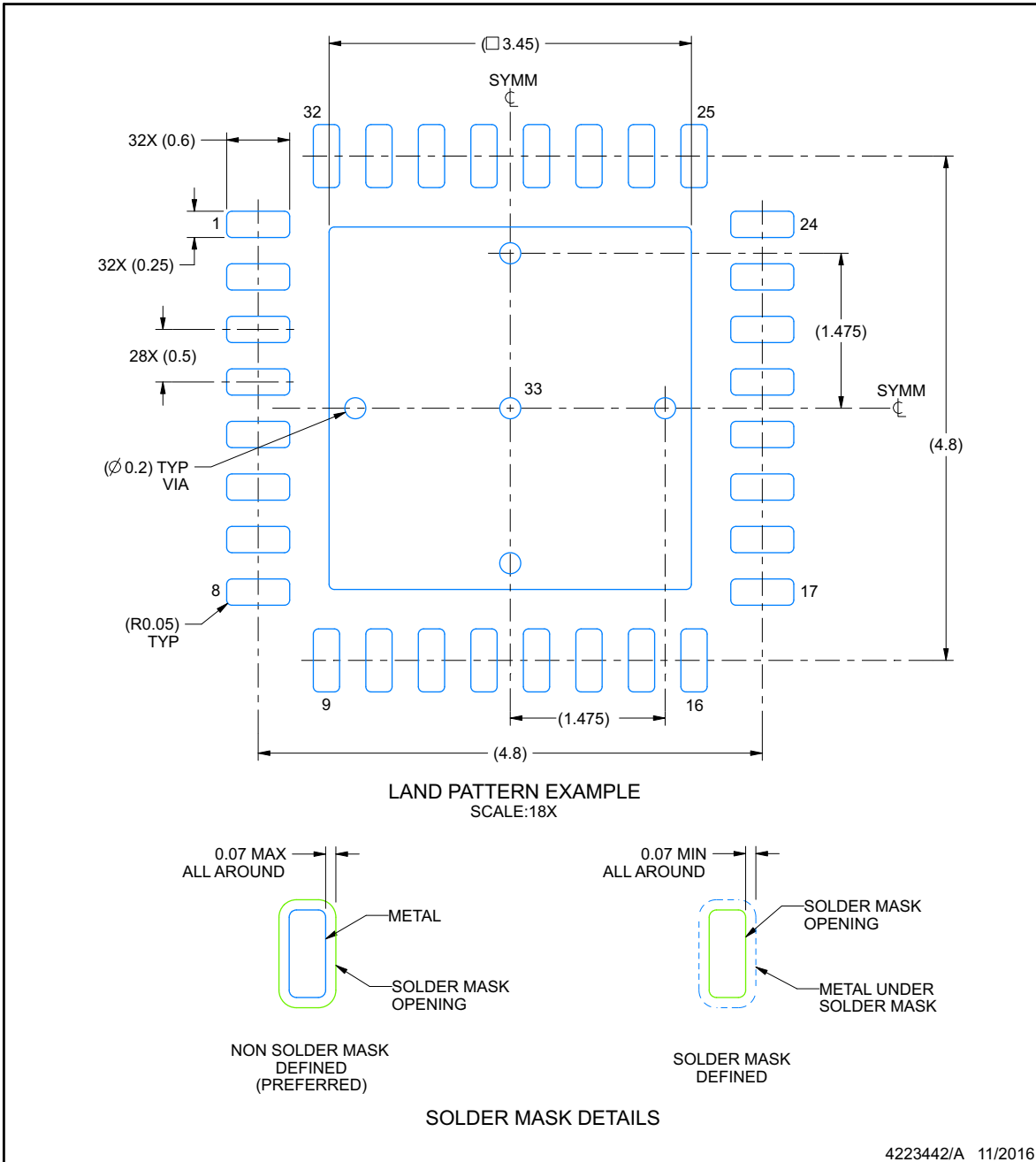

NOTES: (continued)

4. This package is designed to be soldered to a thermal pad on the board. For more information, see Texas Instruments literature number SLUA271 ([www.ti.com/lit/sluea271](http://www.ti.com/lit/sluea271)).
5. Vias are optional depending on application, refer to device data sheet. If any vias are implemented, refer to their locations shown on this view. It is recommended that vias under paste be filled, plugged or tented.

## EXAMPLE STENCIL DESIGN

**RHB0032E**

**VQFN - 1 mm max height**

PLASTIC QUAD FLATPACK - NO LEAD

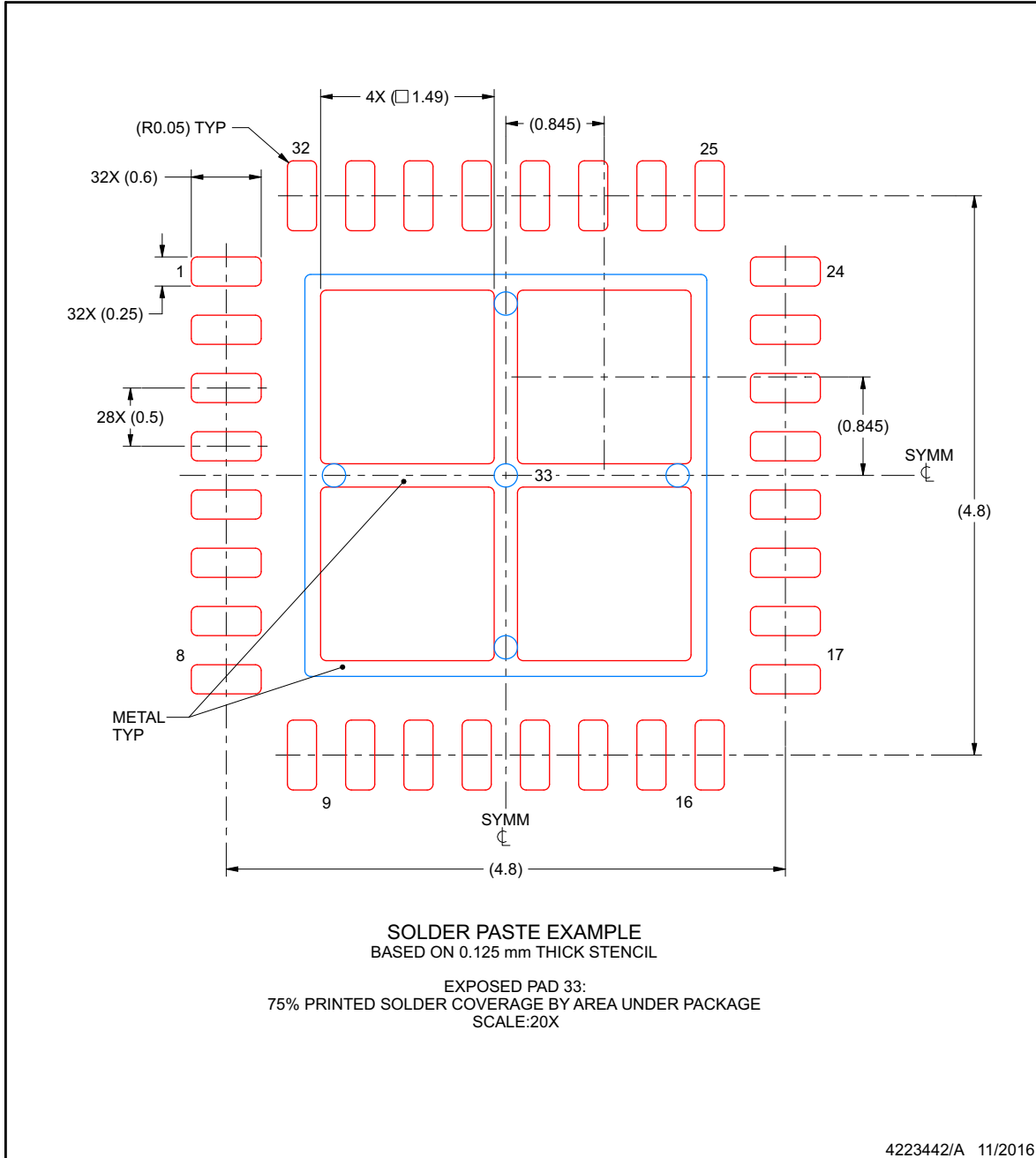

NOTES: (continued)

- 6. Laser cutting apertures with trapezoidal walls and rounded corners may offer better paste release. IPC-7525 may have alternate design recommendations.

## 重要声明和免责声明

TI 均以“原样”提供技术性数据（包括数据表）、设计资源（包括参考设计）、应用或其他设计建议、网络工具、安全信息和其他资源，不保证其中不含任何瑕疵，且不做任何明示或暗示的担保，包括但不限于对适销性、适合某特定用途或不侵犯任何第三方知识产权的暗示担保。

所述资源可供专业开发人员应用TI 产品进行设计使用。您将对以下行为独自承担全部责任：(1) 针对您的应用选择合适的TI 产品；(2) 设计、验证并测试您的应用；(3) 确保您的应用满足相应标准以及任何其他安全、安保或其他要求。所述资源如有变更，恕不另行通知。TI 对您使用所述资源的授权仅限于开发资源所涉及TI 产品的相关应用。除此之外不得复制或展示所述资源，也不提供其它TI 或任何第三方的知识产权授权许可。如因使用所述资源而产生任何索赔、赔偿、成本、损失及债务等，TI 对此概不负责，并且您须赔偿由此对TI 及其代表造成的损害。

TI 所提供产品均受TI 的销售条款 (<http://www.ti.com.cn/zh-cn/legal/termsofsale.html>) 以及ti.com.cn上或随附TI产品提供的其他可适用条款的约束。TI提供所述资源并不扩展或以其他方式更改TI 针对TI 产品所发布的可适用的担保范围或担保免责声明。

邮寄地址：上海市浦东新区世纪大道 1568 号中建大厦 32 楼，邮政编码：200122  
Copyright © 2019 德州仪器半导体技术（上海）有限公司

## PACKAGING INFORMATION

Orderable Device	Status (1)	Package Type	Package Drawing	Pins	Package Qty	Eco Plan (2)	Lead finish/ Ball material (6)	MSL Peak Temp (3)	Op Temp (°C)	Device Marking (4/5)	Samples
ADS1260BIRHBR	ACTIVE	VQFN	RHB	32	3000	RoHS & Green	NIPDAU	Level-3-260C-168 HR	-40 to 125	ADS 1260B	<a href="#">Samples</a>
ADS1260BIRHBT	ACTIVE	VQFN	RHB	32	250	RoHS & Green	NIPDAU	Level-3-260C-168 HR	-40 to 125	ADS 1260B	<a href="#">Samples</a>
ADS1261BIRHBR	ACTIVE	VQFN	RHB	32	3000	RoHS & Green	NIPDAU	Level-3-260C-168 HR	-40 to 125	ADS 1261B	<a href="#">Samples</a>
ADS1261BIRHBT	ACTIVE	VQFN	RHB	32	250	RoHS & Green	NIPDAU	Level-3-260C-168 HR	-40 to 125	ADS 1261B	<a href="#">Samples</a>
ADS1261IRHBR	ACTIVE	VQFN	RHB	32	3000	RoHS & Green	NIPDAU	Level-3-260C-168 HR	-40 to 125	ADS 1261	<a href="#">Samples</a>
ADS1261IRHBT	ACTIVE	VQFN	RHB	32	250	RoHS & Green	NIPDAU	Level-3-260C-168 HR	-40 to 125	ADS 1261	<a href="#">Samples</a>

(1) The marketing status values are defined as follows:

**ACTIVE:** Product device recommended for new designs.

**LIFEBUY:** TI has announced that the device will be discontinued, and a lifetime-buy period is in effect.

**NRND:** Not recommended for new designs. Device is in production to support existing customers, but TI does not recommend using this part in a new design.

**PREVIEW:** Device has been announced but is not in production. Samples may or may not be available.

**OBSOLETE:** TI has discontinued the production of the device.

(2) **RoHS:** TI defines "RoHS" to mean semiconductor products that are compliant with the current EU RoHS requirements for all 10 RoHS substances, including the requirement that RoHS substance do not exceed 0.1% by weight in homogeneous materials. Where designed to be soldered at high temperatures, "RoHS" products are suitable for use in specified lead-free processes. TI may reference these types of products as "Pb-Free".

**RoHS Exempt:** TI defines "RoHS Exempt" to mean products that contain lead but are compliant with EU RoHS pursuant to a specific EU RoHS exemption.

**Green:** TI defines "Green" to mean the content of Chlorine (Cl) and Bromine (Br) based flame retardants meet JS709B low halogen requirements of <=1000ppm threshold. Antimony trioxide based flame retardants must also meet the <=1000ppm threshold requirement.

(3) MSL, Peak Temp. - The Moisture Sensitivity Level rating according to the JEDEC industry standard classifications, and peak solder temperature.

(4) There may be additional marking, which relates to the logo, the lot trace code information, or the environmental category on the device.

(5) Multiple Device Markings will be inside parentheses. Only one Device Marking contained in parentheses and separated by a "~" will appear on a device. If a line is indented then it is a continuation of the previous line and the two combined represent the entire Device Marking for that device.

<sup>(6)</sup> Lead finish/Ball material - Orderable Devices may have multiple material finish options. Finish options are separated by a vertical ruled line. Lead finish/Ball material values may wrap to two lines if the finish value exceeds the maximum column width.

**Important Information and Disclaimer:**The information provided on this page represents TI's knowledge and belief as of the date that it is provided. TI bases its knowledge and belief on information provided by third parties, and makes no representation or warranty as to the accuracy of such information. Efforts are underway to better integrate information from third parties. TI has taken and continues to take reasonable steps to provide representative and accurate information but may not have conducted destructive testing or chemical analysis on incoming materials and chemicals. TI and TI suppliers consider certain information to be proprietary, and thus CAS numbers and other limited information may not be available for release.

In no event shall TI's liability arising out of such information exceed the total purchase price of the TI part(s) at issue in this document sold by TI to Customer on an annual basis.

## TAPE AND REEL INFORMATION

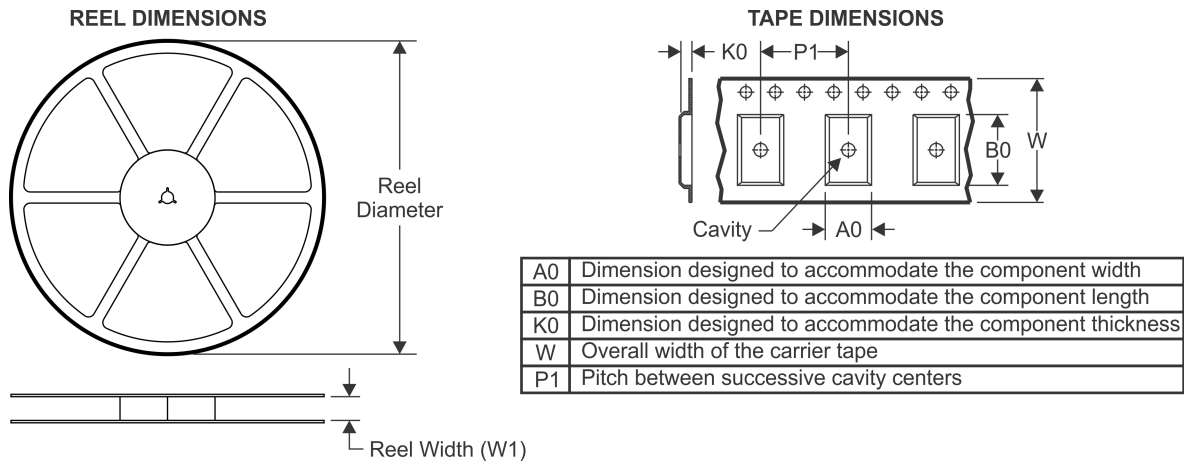

### QUADRANT ASSIGNMENTS FOR PIN 1 ORIENTATION IN TAPE

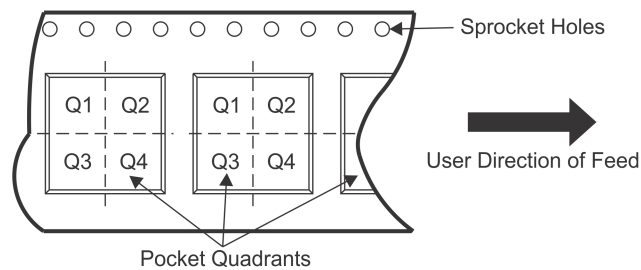

\*All dimensions are nominal

Device	Package Type	Package Drawing	Pins	SPQ	Reel Diameter (mm)	Reel Width W1 (mm)	A0 (mm)	B0 (mm)	K0 (mm)	P1 (mm)	W (mm)	Pin1 Quadrant
ADS1260BIRHBR	VQFN	RHB	32	3000	330.0	12.4	5.3	5.3	1.1	8.0	12.0	Q2
ADS1260BIRHBT	VQFN	RHB	32	250	180.0	12.4	5.3	5.3	1.1	8.0	12.0	Q2
ADS1261BIRHBR	VQFN	RHB	32	3000	330.0	12.4	5.3	5.3	1.1	8.0	12.0	Q2
ADS1261BIRHBT	VQFN	RHB	32	250	180.0	12.4	5.3	5.3	1.1	8.0	12.0	Q2
ADS1261IRHBR	VQFN	RHB	32	3000	330.0	12.4	5.3	5.3	1.1	8.0	12.0	Q2
ADS1261IRHBT	VQFN	RHB	32	250	180.0	12.4	5.3	5.3	1.1	8.0	12.0	Q2

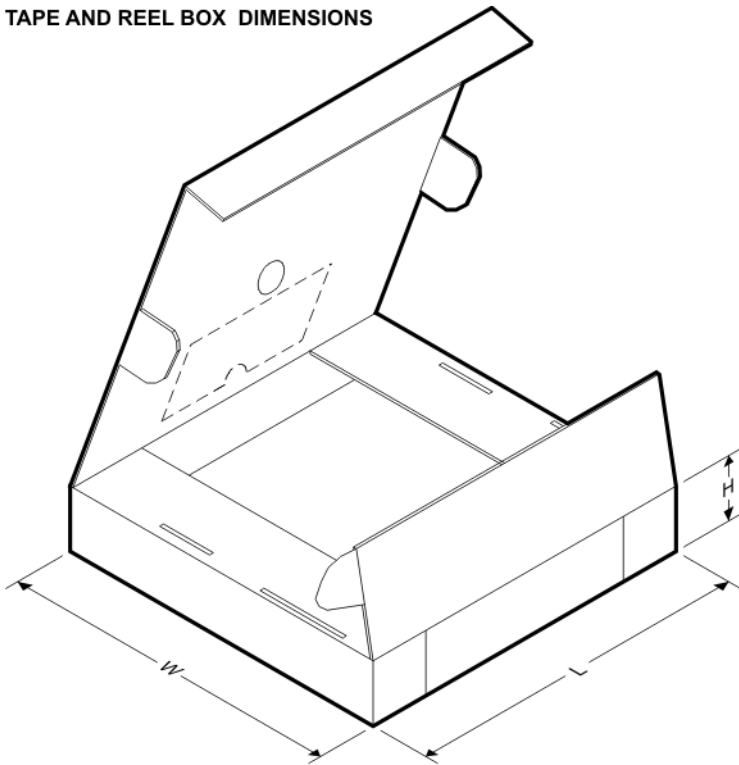
**TAPE AND REEL BOX DIMENSIONS**

\*All dimensions are nominal

Device	Package Type	Package Drawing	Pins	SPQ	Length (mm)	Width (mm)	Height (mm)
ADS1260BIRHBR	VQFN	RHB	32	3000	367.0	367.0	35.0
ADS1260BIRHBT	VQFN	RHB	32	250	210.0	185.0	35.0
ADS1261BIRHBR	VQFN	RHB	32	3000	367.0	367.0	35.0
ADS1261BIRHBT	VQFN	RHB	32	250	210.0	185.0	35.0
ADS1261IRHBR	VQFN	RHB	32	3000	367.0	367.0	35.0
ADS1261IRHBT	VQFN	RHB	32	250	210.0	185.0	35.0

## 重要声明和免责声明

TI 均以“原样”提供技术性 & 可靠性数据（包括数据表）、设计资源（包括参考设计）、应用或其他设计建议、网络工具、安全信息和其他资源，不保证其中不含任何瑕疵，且不做任何明示或暗示的担保，包括但不限于对适销性、适合某特定用途或不侵犯任何第三方知识产权的暗示担保。

所述资源可供专业开发人员应用 TI 产品进行设计使用。您将对以下行为独自承担全部责任：(1) 针对您的应用选择合适的 TI 产品；(2) 设计、验证并测试您的应用；(3) 确保您的应用满足相应标准以及任何其他安全、安保或其他要求。所述资源如有变更，恕不另行通知。TI 对您使用所述资源的授权仅限于开发资源所涉及 TI 产品的相关应用。除此之外不得复制或展示所述资源，也不提供其它 TI 或任何第三方的知识产权授权许可。如因使用所述资源而产生任何索赔、赔偿、成本、损失及债务等，TI 对此概不负责，并且您须赔偿由此对 TI 及其代表造成的损害。

TI 所提供产品均受 TI 的销售条款 (<http://www.ti.com.cn/zh-cn/legal/termsofsale.html>) 以及 [ti.com.cn](http://www.ti.com.cn) 上或随附 TI 产品提供的其他可适用条款的约束。TI 提供所述资源并不扩展或以其他方式更改 TI 针对 TI 产品所发布的可适用的担保范围或担保免责声明。

邮寄地址：上海市浦东新区世纪大道 1568 号中建大厦 32 楼，邮政编码：200122  
Copyright © 2020 德州仪器半导体技术（上海）有限公司