

具有 $\pm 1\text{V}$ 双极输入和 2.5V 基准电压输出的 AMC1035 Δ - Σ 调制器

1 特性

- 针对电压和温度感应进行了优化的 Δ - Σ 调制器：
 - $\pm 1\text{V}$ 输入电压范围
 - 高差分输入电阻： $1.6\text{G}\Omega$ （典型值）
 - 集成 2.5V 、 $\pm 5\text{mA}$ 基准，可实现比例测量
- 出色的直流性能：
 - 失调电压误差： $\pm 0.5\text{mV}$ （最大值）
 - 温漂： $\pm 6\mu\text{V}/^\circ\text{C}$ （最大值）
 - 增益误差： $\pm 0.25\%$ （最大值）
 - 增益漂移： $\pm 45\text{ppm}/^\circ\text{C}$ （最大值）
 - 比例增益漂移： $\pm 15\text{ppm}/^\circ\text{C}$ （最大值）
- 可选曼彻斯特编码式或未编码式位流输出
- 完整的额定工作温度范围： -40°C 至 $+125^\circ\text{C}$

2 应用

- 工业应用中的交流电压和温度感应：
 - 电机驱动器
 - 光电逆变器
 - 不间断电源
 - 工业运输系统

3 说明

AMC1035 是一款精密 Δ - Σ 调制器，可在 3.0V 至 5.5V 的单电源下运行，且具有 9MHz 至 21MHz 的时钟信号。在曼彻斯特模式下，额定时钟范围为 9MHz 至 11MHz 。该器件的差分 $\pm 1\text{V}$ 输入结构经过优化，可适应工业应用中的典型高噪声环境。

AMC1035 可选择曼彻斯特编码式输出位流，这样便无需考虑接收器件的设置和保留时间要求并减少总体电路布局工作。当用于与数字滤波器（例如集成到 [TMS320F28004x](#)、[TMS320F2807x](#) 或 [TMS320F2837x](#) 微控制器系列中）一起抽取输出位流时，该器件可在 82kSPS 的数据速率下实现具有 87dB 动态范围的 16 位分辨率。

AMC1035 的内部基准源支持比例电路架构，可最大限度降低电源电压变化和温漂对测量精度的负面影响。

AMC1035 还可用于与数字隔离器和隔离电源一起实现交流电力线电压检测。

器件信息⁽¹⁾

器件型号	封装	封装尺寸（标称值）
AMC1035	SOIC (8)	4.9mm x 3.9mm

(1) 如需了解所有可用封装，请参阅数据表末尾的可订购产品附录。

应用示例

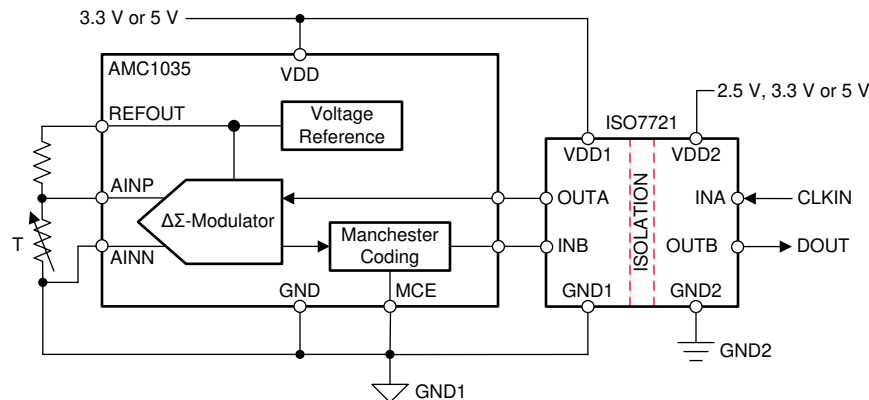

目录

1	特性	1	7.4	Device Functional Modes	18
2	应用	1	8	Application and Implementation	19
3	说明	1	8.1	Application Information	19
4	修订历史记录	2	8.2	Typical Applications	20
5	Pin Configuration and Functions	3	9	Power Supply Recommendations	24
6	Specifications	4	10	Layout	25
6.1	Absolute Maximum Ratings	4	10.1	Layout Guidelines	25
6.2	ESD Ratings	4	10.2	Layout Example	25
6.3	Recommended Operating Conditions	4	11	器件和文档支持	26
6.4	Thermal Information	5	11.1	文档支持	26
6.5	Electrical Characteristics	5	11.2	接收文档更新通知	26
6.6	Switching Characteristics	7	11.3	社区资源	26
6.7	Typical Characteristics	8	11.4	商标	26
7	Detailed Description	14	11.5	静电放电警告	26
7.1	Overview	14	11.6	Glossary	26
7.2	Functional Block Diagram	14	12	机械、封装和可订购信息	26
7.3	Feature Description	14			

4 修订历史记录

注：之前版本的页码可能与当前版本有所不同。

Changes from Revision A (November 2018) to Revision B	Page
• Deleted PSRR specification for $T_A > 85^\circ\text{C}$ from <i>Reference Output</i> section of <i>Electrical Characteristics</i> table	6
• 已更改 SINAD equation	22

Changes from Original (August 2018) to Revision A	Page
• 已更改 将文档状态从“预告信息”更改为“生产数据”	1

5 Pin Configuration and Functions

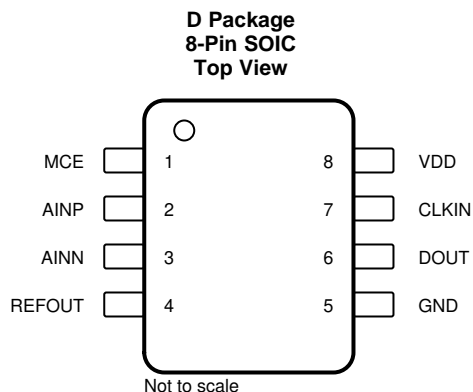

Pin Functions

PIN		I/O	DESCRIPTION
NO.	NAME		
1	MCE	I	Manchester coding enabled, active high, with internal pulldown resistor (typical value: 200 k Ω). The polarity of this signal must not be changed when the clock signal is applied.
2	AINP	I	Noninverting analog input.
3	AINN	I	Inverting analog input.
4	REFOUT	O	Reference output: 2.5 V nominal, maximum ± 5 -mA sink and source capability.
5	GND	—	Ground reference.
6	DOUT	O	Modulator bitstream data output, updated with the rising edge of the clock signal present on CLKIN. This pin is a Manchester coded output if MCE is pulled high. Use the rising edge of the clock to latch the modulator bitstream at the input of the digital filter device.
7	CLKIN	I	Modulator clock input: 9 MHz to 21 MHz with an internal pulldown resistor (typical value: 200 k Ω). The clock signal must be applied continuously for proper device operation; see the Clock Input section for additional details.
8	VDD	—	Power supply, 3.0 V to 5.5 V. See the Power Supply Recommendations section for decoupling recommendations.

6 Specifications

6.1 Absolute Maximum Ratings

see ⁽¹⁾

	MIN	MAX	UNIT
Supply voltage, VDD to GND	-0.3	7	V
Analog input voltage at AINP, AINN	GND – 5	VDD + 0.5	V
Analog output voltage at REFOUT	GND – 0.5	VDD + 0.5	V
Digital input voltage at CLKIN or MCE	GND – 0.5	VDD + 0.5	V
Digital output voltage at DOUT	GND – 0.5	VDD + 0.5	V
Input current to any pin except supply pins	-10	10	mA
Junction temperature, T _J		150	°C
Storage temperature, T _{stg}	-65	150	°C

- (1) Stresses beyond those listed under *Absolute Maximum Ratings* may cause permanent damage to the device. These are stress ratings only, and do not imply functional operation of the device at these or any other conditions beyond those indicated under *Recommended Operating Conditions*. Exposure to absolute-maximum-rated conditions for extended periods may affect device reliability.

6.2 ESD Ratings

			VALUE	UNIT
V _(ESD)	Electrostatic discharge	Human-body model (HBM), per ANSI/ESDA/JEDEC JS-001 ⁽¹⁾	±2000	V
		Charged-device model (CDM), per JEDEC specification JESD22-C101 ⁽²⁾	±1000	

- (1) JEDEC document JEP155 states that 500-V HBM allows safe manufacturing with a standard ESD control process.
 (2) JEDEC document JEP157 states that 250-V CDM allows safe manufacturing with a standard ESD control process.

6.3 Recommended Operating Conditions

over operating ambient temperature range (unless otherwise noted)

				MIN	NOM	MAX	UNIT
POWER SUPPLY							
VDD	Supply voltage	VDD to GND		3.0	3.3	5.5	V
ANALOG INPUT							
V _{Clipping}	Differential input voltage before clipping output	V _{IN} = V _{AINP} – V _{AINN}		±1.25			V
V _{FSR}	Specified linear differential full-scale voltage	V _{IN} = V _{AINP} – V _{AINN}		-1		1	V
	Absolute common-mode input voltage ⁽¹⁾	(V _{AINP} + V _{AINN}) / 2 to GND		-2		VDD	V
V _{CM}	Operating common-mode input voltage ⁽²⁾	(V _{AINP} + V _{AINN}) / 2 to GND, 3.0 V ≤ VDD < 4 V, V _{AINP} = V _{AINN}		-1.4		VDD – 1.4	V
		(V _{AINP} + V _{AINN}) / 2 to GND, 3.0 V ≤ VDD < 4.5 V, V _{AINP} – V _{AINN} = 1.25 V		-0.8		VDD – 2.4	
		(V _{AINP} + V _{AINN}) / 2 to GND, 4 V ≤ VDD ≤ 5.5 V, V _{AINP} = V _{AINN}		-1.4		2.7	
		(V _{AINP} + V _{AINN}) / 2 to GND, 4.5 V ≤ VDD ≤ 5.5 V, V _{AINP} – V _{AINN} = 1.25 V		-0.8		2.1	
DIGITAL INPUT							
	Input voltage	V _{MCE} or V _{CLKIN} to GND		GND		VDD	V
TEMPERATURE RANGE							
T _A	Operating ambient temperature			-40	25	125	°C

- (1) Steady-state voltage supported by the device in case of a system failure. See specified common-mode input voltage V_{CM} for normal operation. Observe analog input voltage range as specified in the *Absolute Maximum Ratings* table.
 (2) See the *Analog Input* section for more details.

6.4 Thermal Information

THERMAL METRIC ⁽¹⁾		AMC1035	UNIT
		D (SOIC)	
		8 PINS	
R _{θJA}	Junction-to-ambient thermal resistance	120	°C/W
R _{θJC(top)}	Junction-to-case (top) thermal resistance	52	°C/W
R _{θJB}	Junction-to-board thermal resistance	61	°C/W
ψ _{JT}	Junction-to-top characterization parameter	10	°C/W
ψ _{JB}	Junction-to-board characterization parameter	60	°C/W
R _{θJC(bot)}	Junction-to-case (bottom) thermal resistance	n/a	°C/W

(1) For more information about traditional and new thermal metrics, see the [Semiconductor and IC Package Thermal Metrics](#) application report.

6.5 Electrical Characteristics

minimum and maximum specifications apply from T_A = –40°C to +125°C, VDD = 3.0 V to 5.5 V, AINP = –1 V to 1 V, AINN = GND, and sinc³ filter with OSR = 256 (unless otherwise noted); typical specifications are at T_A = 25°C, CLKIN = 20 MHz, and VDD = 3.3 V

PARAMETER		TEST CONDITIONS	MIN	TYP	MAX	UNIT
ANALOG INPUTS						
V _{CMuv} ⁽¹⁾	Negative common-mode undervoltage detection level ⁽²⁾	(V _{AINP} + V _{AINN}) / 2, V _{AINP} = V _{AINN}			–1.45	V
		(V _{AINP} + V _{AINN}) / 2, V _{AINP} – V _{AINN} = 1.25 V			–0.85	
V _{CMov} ⁽¹⁾	Positive common-mode overvoltage detection level ⁽²⁾	3.0 V ≤ VDD < 4 V, V _{AINP} = V _{AINN}			VDD – 1.35	V
		3.0 V ≤ VDD < 4.5 V, V _{AINP} – V _{AINN} = 1.25 V			VDD – 2.35	
		4 V ≤ VDD ≤ 5.5 V, V _{AINP} = V _{AINN}	2.75			
		4.5 V ≤ VDD ≤ 5.5 V, V _{AINP} – V _{AINN} = 1.25 V	2.15			
R _{IN}	Single-ended input resistance	AINN = GND	0.1	0.4		GΩ
R _{IND}	Differential input resistance		0.16	1.6		GΩ
C _{IN}	Single-ended input capacitance	AINN = GND		2		pF
C _{IND}	Differential input capacitance			2		pF
I _{IB}	Input bias current	AINP = AINN = GND, (I _{AINP} + I _{AINN}) / 2	–10	±3	10	nA
TC _{IB}	Input bias current thermal drift	AINP = AINN = GND, (I _{AINP} + I _{AINN}) / 2		±5		pA/°C
I _{IO}	Input offset current	I _{IO} = I _{AINP} – I _{AINN}	–5	±1	5	nA
CMRR	Common-mode rejection ratio	AINP = AINN, f _{IN} = 0 Hz, V _{CM min} ≤ V _{IN} ≤ V _{CM max}			–104	dB
		AINP = AINN, f _{IN} from 0.1 Hz to 50 kHz, –0.5 V ≤ V _{IN} ≤ 0.5 V			–88	
DC ACCURACY						
	Resolution ⁽³⁾		16			Bits
INL	Integral nonlinearity ⁽⁴⁾	Resolution: 16 bits	–12	±2	12	LSB
E _O	Offset error	Initial, at T _A = 25°C, AINP = AINN = GND	–0.5	±0.03	0.5	mV
TCE _O	Offset error thermal drift ⁽⁵⁾		–6	±0.1	6	μV/°C
E _G	Gain error	Initial, at T _A = 25°C	–0.25%	±0.02%	0.25%	
		Initial, at T _A = 25°C, ratiometric mode	–0.3%	±0.02%	0.3%	
TCE _G	Gain error thermal drift ⁽⁶⁾		–45	±20	45	ppm/°C
		Ratiometric mode	–15	±4	15	
PSRR	Power-supply rejection ratio	AINP = AINN = GND, at dc			–90	dB
		AINP = AINN = GND, 10 kHz, 100-mV ripple			–84	

(1) See the [Analog Input](#) section for more details.

(2) The common-mode overvoltage detection level has a typical hysteresis of 35 mV.

(3) The filter output is truncated to 16 bits. 16 bits of no missing codes is specified by design.

(4) Integral nonlinearity is defined as the maximum deviation from a straight line passing through the end-points of the ideal ADC transfer function expressed as number of LSBs or as a percent of the specified linear full-scale range FSR.

(5) Offset error drift is calculated using the box method, as described by the following equation:

$$TCE_o = \frac{value_{MAX} - value_{MIN}}{TempRange}$$

(6) Gain error drift is calculated using the box method, as described by the following equation:

$$TCE_G(ppm) = \left(\frac{value_{MAX} - value_{MIN}}{value \times TempRange} \right) \times 10^6$$

Electrical Characteristics (continued)

minimum and maximum specifications apply from $T_A = -40^{\circ}\text{C}$ to $+125^{\circ}\text{C}$, $V_{DD} = 3.0\text{ V}$ to 5.5 V , $A_{INP} = -1\text{ V}$ to 1 V , $A_{INN} = \text{GND}$, and sinc³ filter with $\text{OSR} = 256$ (unless otherwise noted); typical specifications are at $T_A = 25^{\circ}\text{C}$, $\text{CLKIN} = 20\text{ MHz}$, and $V_{DD} = 3.3\text{ V}$

PARAMETER		TEST CONDITIONS	MIN	TYP	MAX	UNIT
AC ACCURACY						
SNR	Signal-to-noise ratio	$f_{IN} = 1\text{ kHz}$	81	87		dB
SINAD	Signal-to-noise + distortion	$f_{IN} = 1\text{ kHz}$	77	83		dB
THD	Total harmonic distortion	$f_{IN} = 1\text{ kHz}$		-87	-78	dB
SFDR	Spurious-free dynamic range	$f_{IN} = 1\text{ kHz}$	78	87		dB
REFERENCE OUTPUT						
V_{REFOUT}	Reference output voltage	Initial, at $T_A = 25^{\circ}\text{C}$, no load	2.495	2.5	2.505	V
$\text{TCV}_{\text{REFOUT}}$	Reference output voltage drift		-50	± 20	50	ppm/ $^{\circ}\text{C}$
I_{REFOUT}	Reference output current	$C_{\text{LOAD}} < 1\text{ nF}^{(7)}$	-5		5	mA
	Load regulation	Load to GND or VDD		0.15	0.35	mV/mA
I_{SC}	Short-circuit current	REFOUT to GND		23		mA
		REFOUT to VDD		-21		
PSRR	Power-supply rejection ratio		-200	± 30	200	$\mu\text{V/V}$
DIGITAL INPUTS (CMOS Logic With Schmitt-Trigger)						
I_{IN}	Input current	$\text{GND} \leq V_{\text{IN}} \leq \text{VDD}$			35	μA
C_{IN}	Input capacitance			3		pF
V_{IH}	High-level input voltage		$0.7 \times \text{VDD}$		$\text{VDD} + 0.3$	V
V_{IL}	Low-level input voltage		-0.3		$0.3 \times \text{VDD}$	V
DIGITAL OUTPUT: CMOS						
C_{LOAD}	Output load capacitance	$f_{\text{CLKIN}} = 21\text{ MHz}$		15	30	pF
V_{OH}	High-level output voltage	$I_{\text{OH}} = -20\text{ }\mu\text{A}$	$\text{VDD} - 0.1$			V
		$I_{\text{OH}} = -4\text{ mA}$	$\text{VDD} - 0.4$			
V_{OL}	Low-level output voltage	$I_{\text{OL}} = 20\text{ }\mu\text{A}$			0.1	V
		$I_{\text{OL}} = 4\text{ mA}$			0.4	
POWER SUPPLY						
I_{VDD}	High-side supply current	$3.0\text{ V} \leq \text{VDD} \leq 3.6\text{ V}$, $I_{\text{REFOUT}} = 0\text{ mA}$, $\text{MCE} = 0$, $C_{\text{LOAD}} = 15\text{ pF}$		5.2	6.8	mA
		$3.0\text{ V} \leq \text{VDD} \leq 3.6\text{ V}$, $I_{\text{REFOUT}} = 0\text{ mA}$, $\text{MCE} = 1$, $C_{\text{LOAD}} = 15\text{ pF}^{(8)}$		4.6	6.1	
		$4.5\text{ V} \leq \text{VDD} \leq 5.5\text{ V}$, $I_{\text{REFOUT}} = 0\text{ mA}$, $\text{MCE} = 0$, $C_{\text{LOAD}} = 15\text{ pF}$		6.4	8.3	
		$4.5\text{ V} \leq \text{VDD} \leq 5.5\text{ V}$, $I_{\text{REFOUT}} = 0\text{ mA}$, $\text{MCE} = 1$, $C_{\text{LOAD}} = 15\text{ pF}^{(8)}$		5.4	7.2	

(7) Capacitive load with a value $\geq 1\text{ nF}$ requires series resistor to be connected to the REFOUT pin. See the [Reference Output](#) section for more details.

(8) Typical value is specified at $f_{\text{CLKIN}} = 10\text{ MHz}$, maximum value is specified at $f_{\text{CLKIN}} = 11\text{ MHz}$.

6.6 Switching Characteristics

over operating free-air temperature range (unless otherwise noted)

PARAMETER		TEST CONDITIONS	MIN	TYP	MAX	UNIT
f _{CLKIN}	CLKIN clock frequency	MCE = 0	9	20	21	MHz
		MCE = 1	9	10	11	
Duty _{Cycle}	CLKIN clock duty cycle ⁽¹⁾		40%	50%	60%	
t _{H1}	DOUT hold time after rising edge of CLKIN	MCE = 0, C _{LOAD} = 15 pF	6			ns
t _{H2}	DOUT hold time after rising edge of CLKIN	MCE = 1, C _{LOAD} = 15 pF	6		23	ns
t _{H3}	DOUT hold time after falling edge of CLKIN	MCE = 1, C _{LOAD} = 15 pF	10		26	ns
t _{D1}	Rising edge of CLKIN to DOUT valid delay	MCE = 0, C _{LOAD} = 15 pF			25	ns
t _{D2}	Rising edge of CLKIN to DOUT valid delay	MCE = 1, C _{LOAD} = 15 pF	11		27	ns
t _{D3}	Falling edge of CLKIN to DOUT valid delay	MCE = 1, C _{LOAD} = 15 pF	15		30	ns
t _r	DOUT rise time	10% to 90%, 3.0 V ≤ VDD ≤ 3.6 V, C _{LOAD} = 15 pF		2.5	5	ns
		10% to 90%, 4.5 V ≤ VDD ≤ 5.5 V, C _{LOAD} = 15 pF		1.5	3.5	
t _f	DOUT fall time	90% to 10%, 3.0 V ≤ VDD ≤ 3.6 V, C _{LOAD} = 15 pF		2.5	5.8	ns
		90% to 10%, 4.5 V ≤ VDD ≤ 5.5 V, C _{LOAD} = 15 pF		1.8	4.4	
t _{ASTART}	Analog startup time	VDD step to 3.0 V, 0.1% settling, CLKIN applied		0.25		ms

(1) The duty cycle of DOUT equals the clock duty cycle of the applied CLKIN signal.



图 1. Digital Interface Timing



图 2. Device Startup Timing

6.7 Typical Characteristics

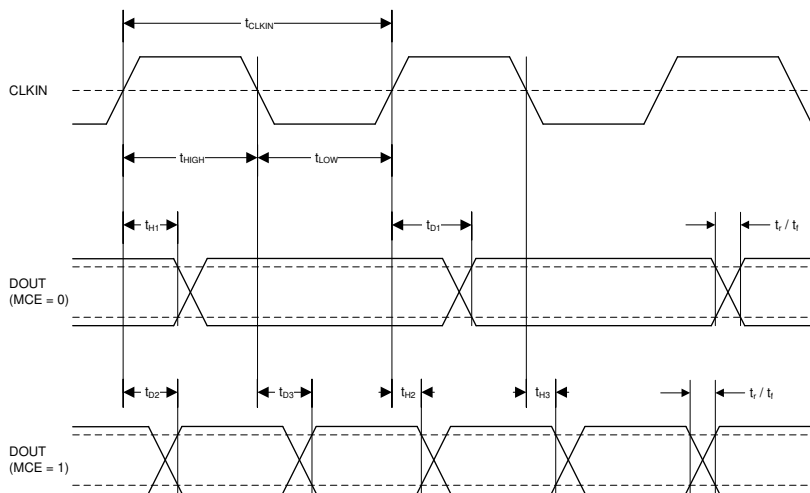
at $V_{DD} = 3.3\text{ V}$, $A_{INP} = -1\text{ V}$ to 1 V , $A_{INN} = \text{GND}$, $f_{CLKIN} = 20\text{ MHz}$, $MCE = 0$, and sinc^3 filter with $\text{OSR} = 256$ (unless otherwise noted)

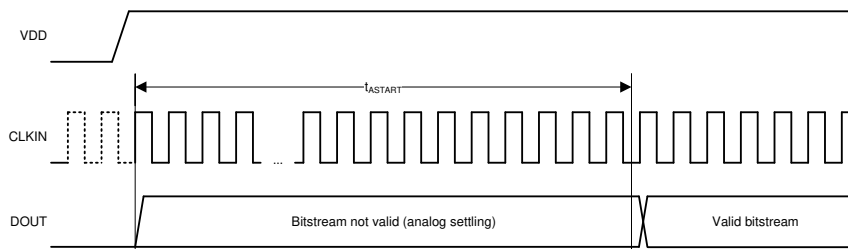

图 3. Input Bias Current vs Common-Mode Input Voltage



图 4. Common-Mode Rejection Ratio vs Input Signal Frequency

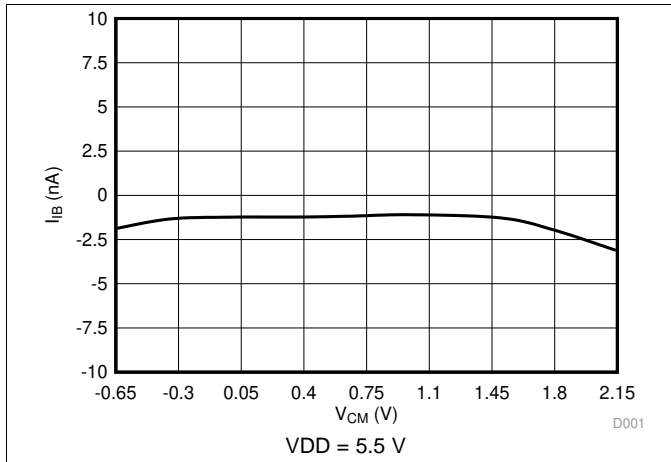

图 5. Integral Nonlinearity vs Input Voltage

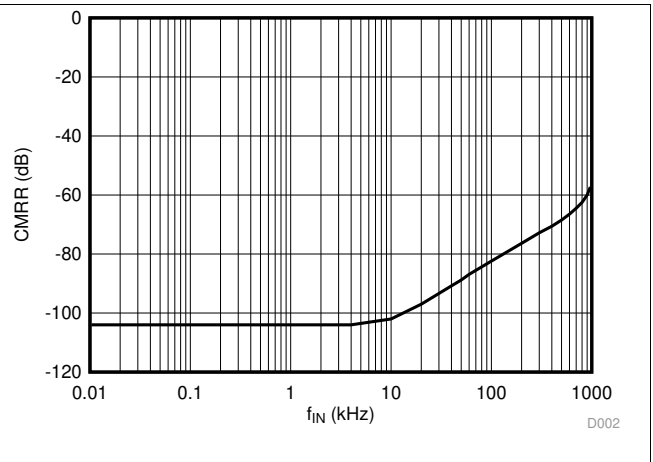

图 6. Integral Nonlinearity vs Temperature

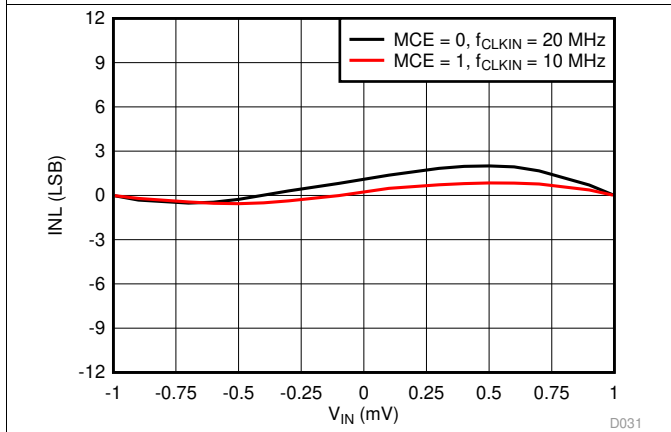

图 7. Offset Error vs Supply Voltage

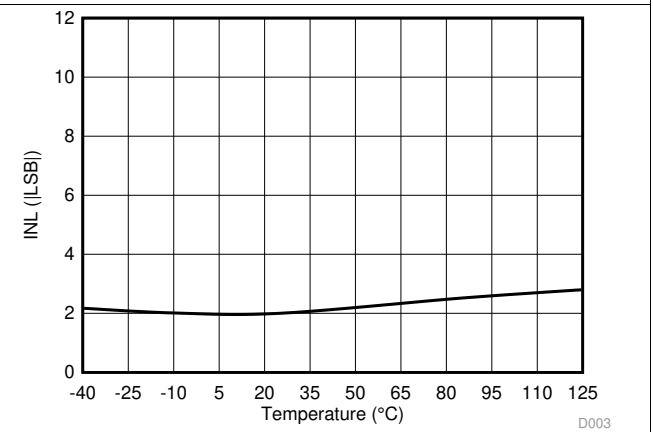

图 8. Offset Error vs Temperature

Typical Characteristics (接下页)

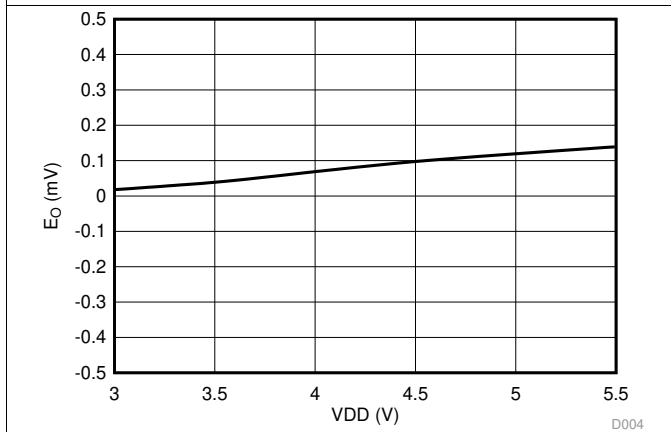
at VDD = 3.3 V, AINP = -1 V to 1 V, AINN = GND, f_{CLKIN} = 20 MHz, MCE = 0, and sinc³ filter with OSR = 256 (unless otherwise noted)

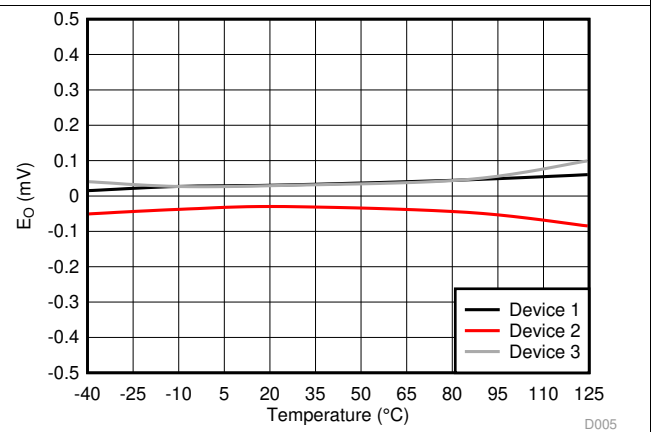

图 9. Offset Error vs Clock Frequency



图 10. Gain Error vs Supply Voltage

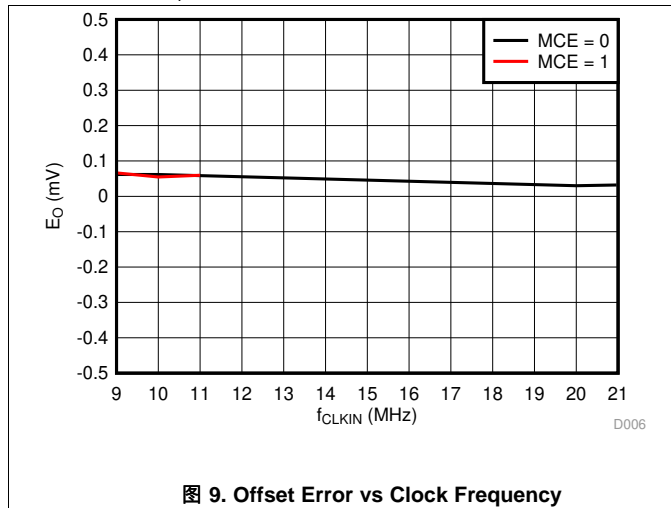

图 11. Gain Error vs Temperature

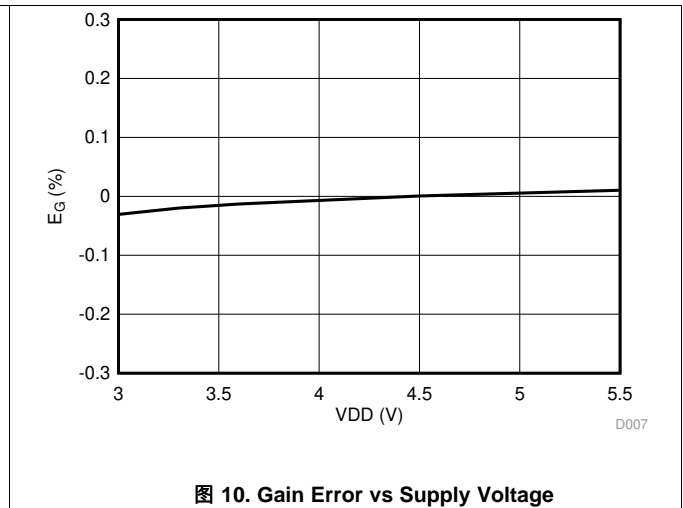

图 12. Ratiometric Gain Error vs Temperature

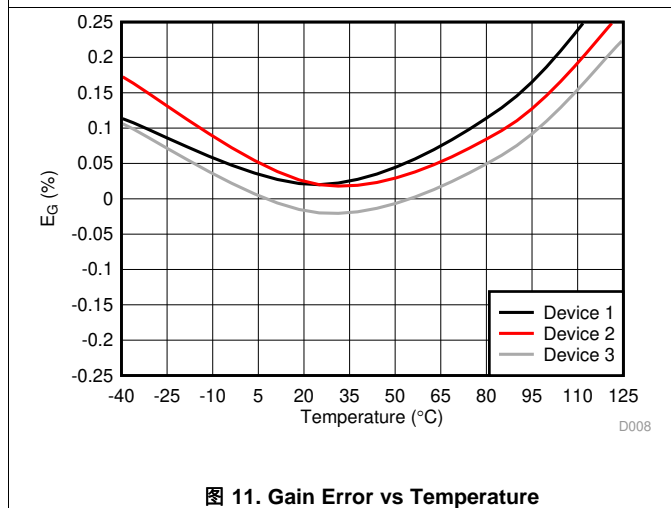

图 13. Gain Error vs Clock Frequency

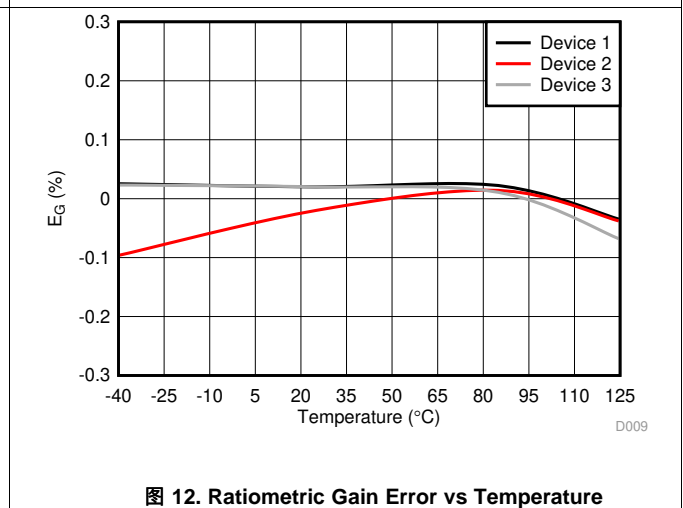

图 14. Power-Supply Rejection Ratio vs Ripple Frequency

Typical Characteristics (接下页)

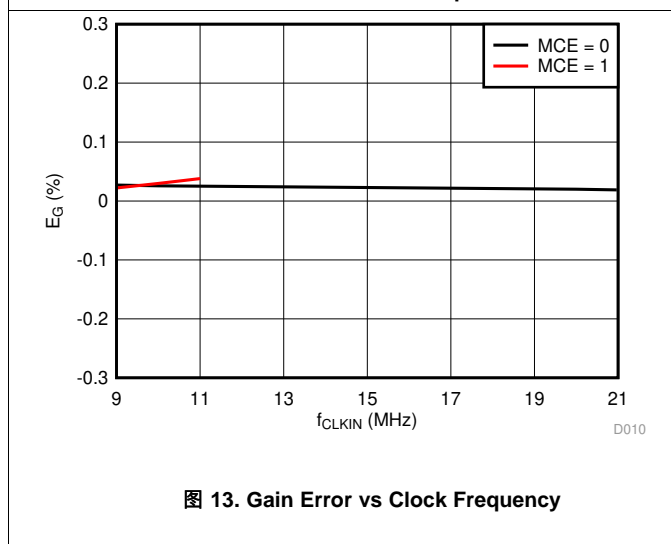
at VDD = 3.3 V, AINP = -1 V to 1 V, AINN = GND, f_{CLKIN} = 20 MHz, MCE = 0, and sinc³ filter with OSR = 256 (unless otherwise noted)

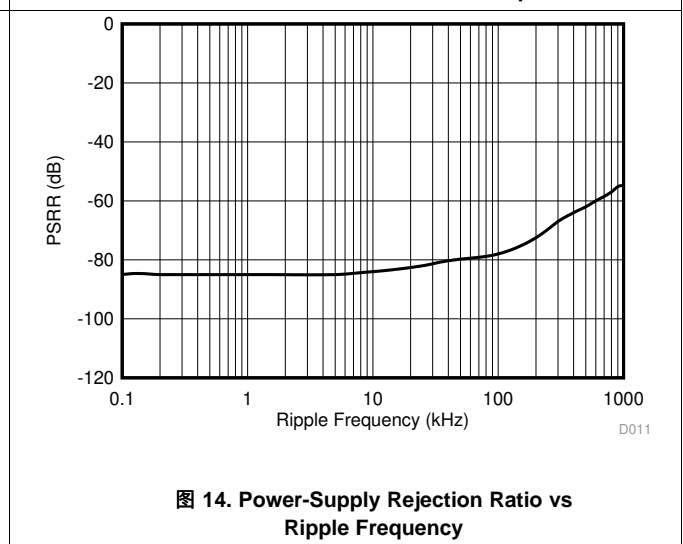

图 15. Signal-to-Noise Ratio and Signal-to-Noise + Distortion vs Supply Voltage



图 16. Signal-to-Noise Ratio and Signal-to-Noise + Distortion vs Temperature

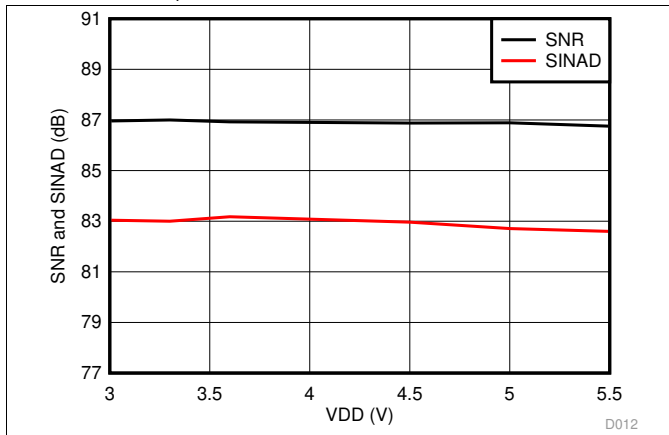

图 17. Signal-to-Noise Ratio and Signal-to-Noise + Distortion vs Clock Frequency

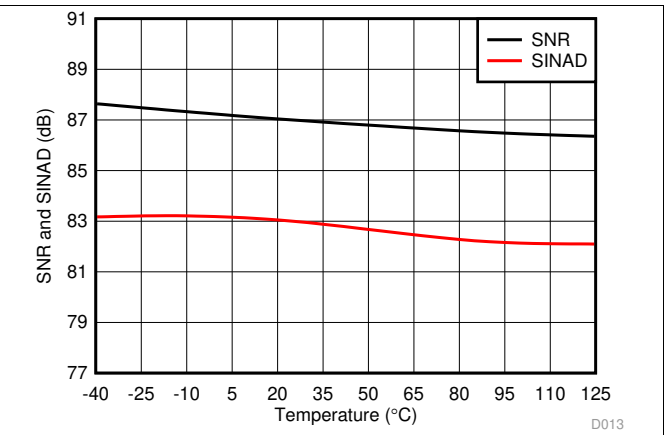

图 18. Signal-to-Noise Ratio and Signal-to-Noise + Distortion vs Input Signal Frequency

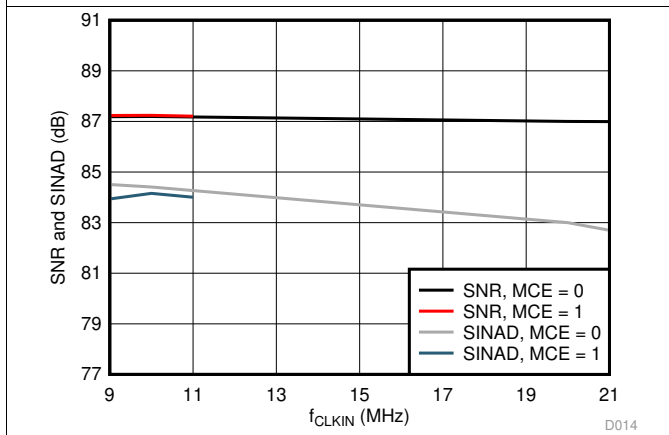

图 19. Signal-to-Noise Ratio and Signal-to-Noise + Distortion vs Input Signal Amplitude

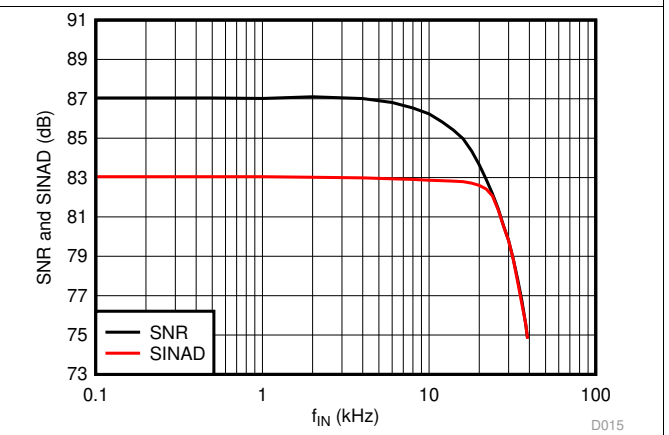

图 20. Total Harmonic Distortion vs Supply Voltage

Typical Characteristics (接下页)

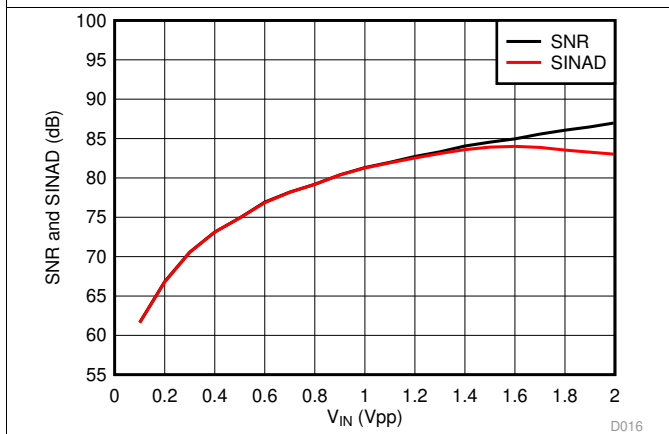
at VDD = 3.3 V, AINP = -1 V to 1 V, AINN = GND, f_{CLKIN} = 20 MHz, MCE = 0, and sinc³ filter with OSR = 256 (unless otherwise noted)

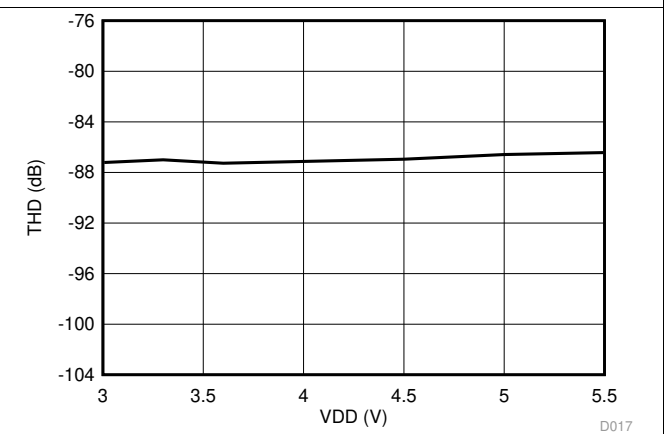

图 21. Total Harmonic Distortion vs Temperature



图 22. Total Harmonic Distortion vs Clock Frequency

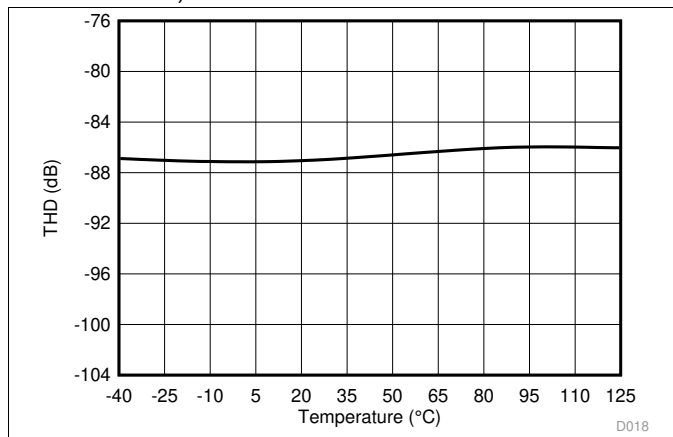

图 23. Total Harmonic Distortion vs Input Signal Frequency

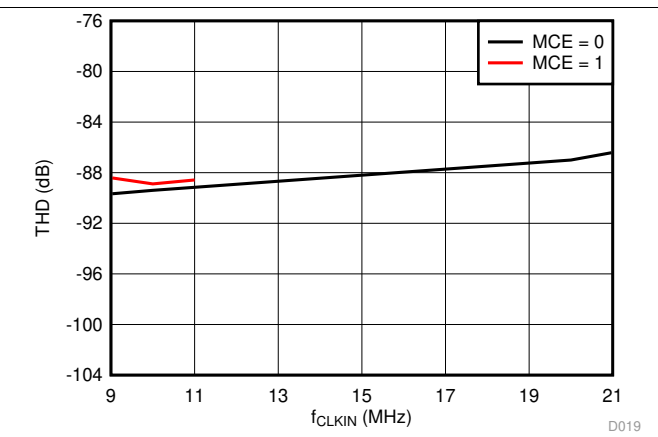

图 24. Total Harmonic Distortion vs Input Signal Amplitude

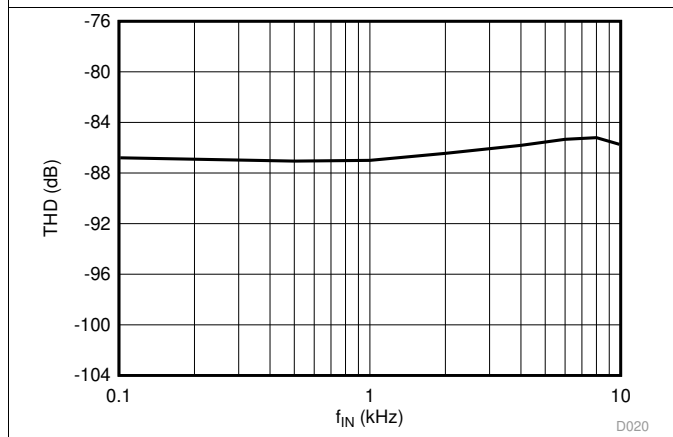

图 25. Spurious-Free Dynamic Range vs Supply Voltage

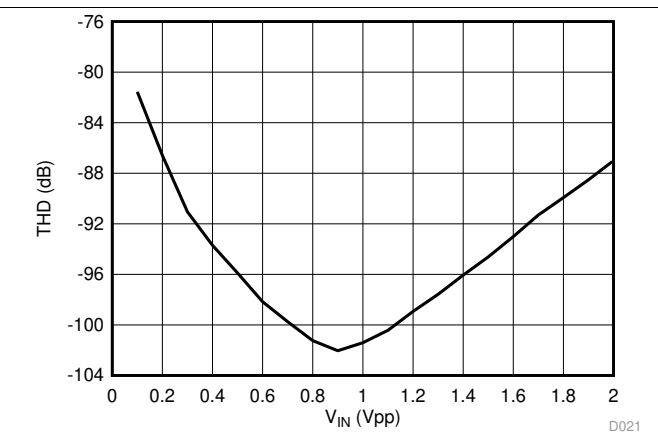

图 26. Spurious-Free Dynamic Range vs Temperature

Typical Characteristics (接下页)

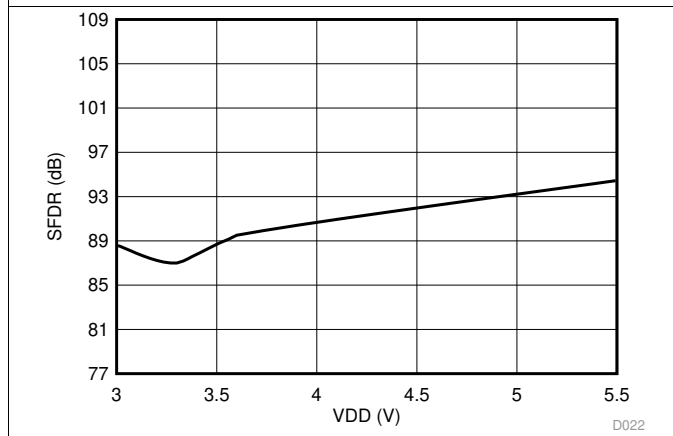
at VDD = 3.3 V, AINP = -1 V to 1 V, AINN = GND, fCLKIN = 20 MHz, MCE = 0, and sinc³ filter with OSR = 256 (unless otherwise noted)

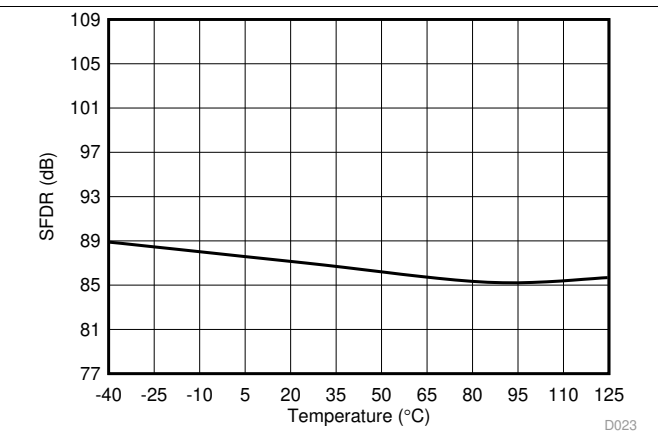
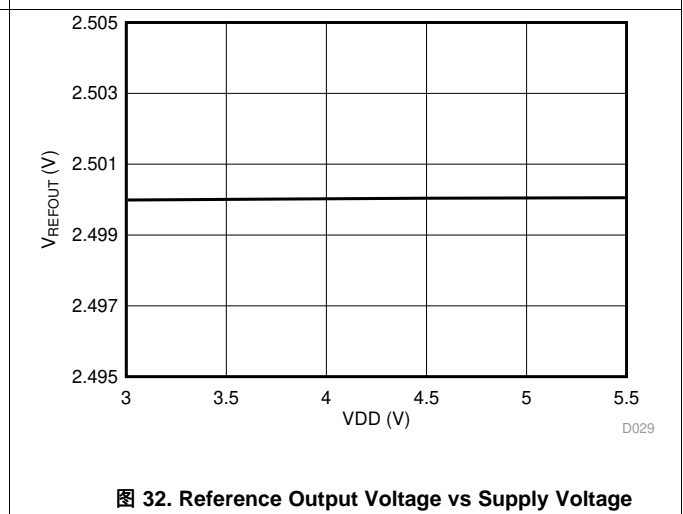
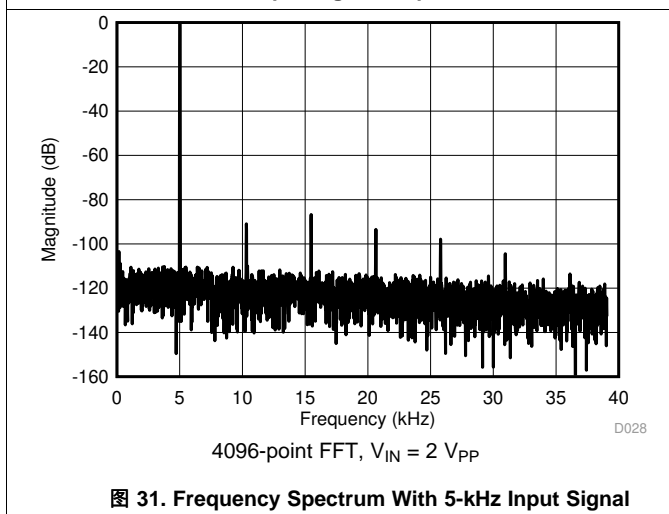
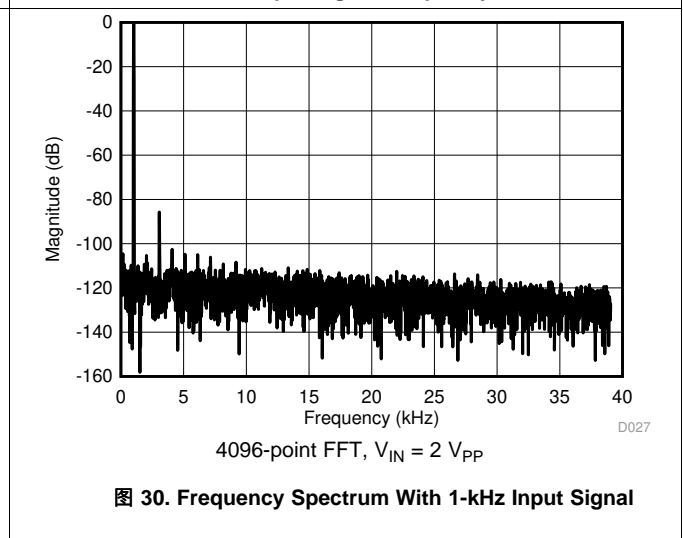
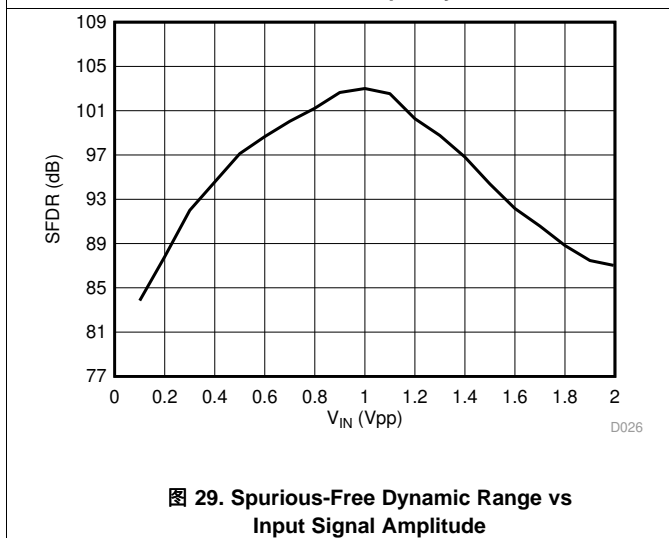
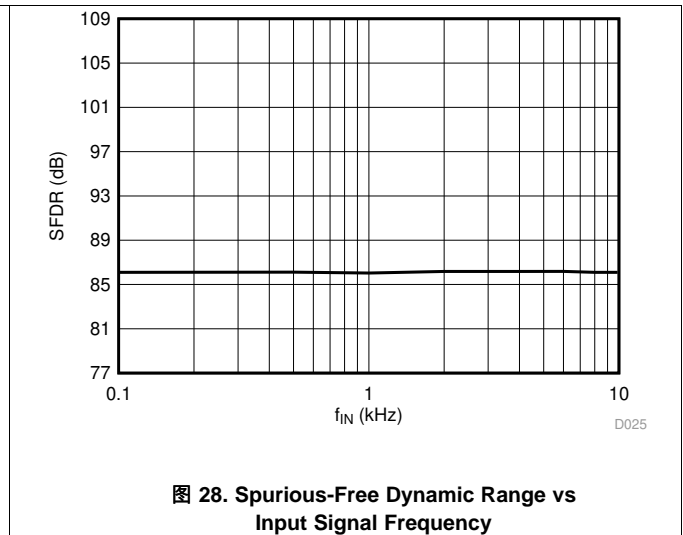
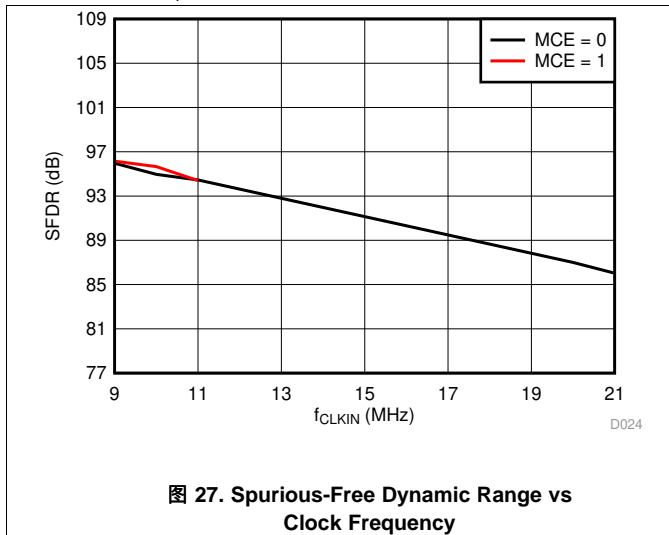

Typical Characteristics (接下页)

at VDD = 3.3 V, AINP = -1 V to 1 V, AINN = GND, f_{CLKIN} = 20 MHz, MCE = 0, and sinc³ filter with OSR = 256 (unless otherwise noted)

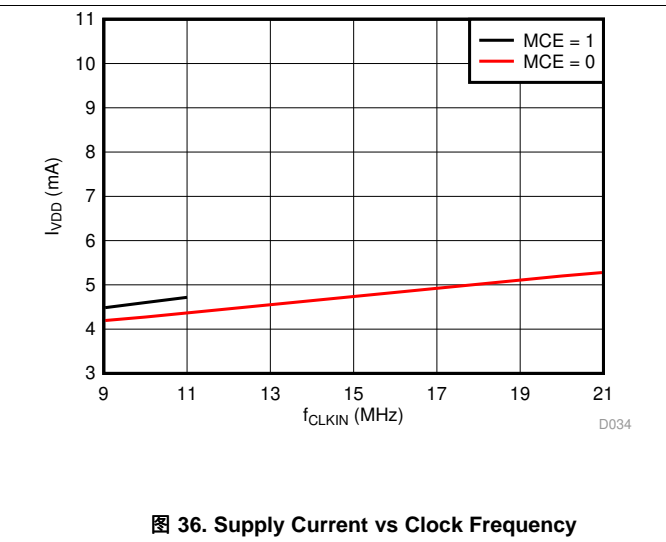
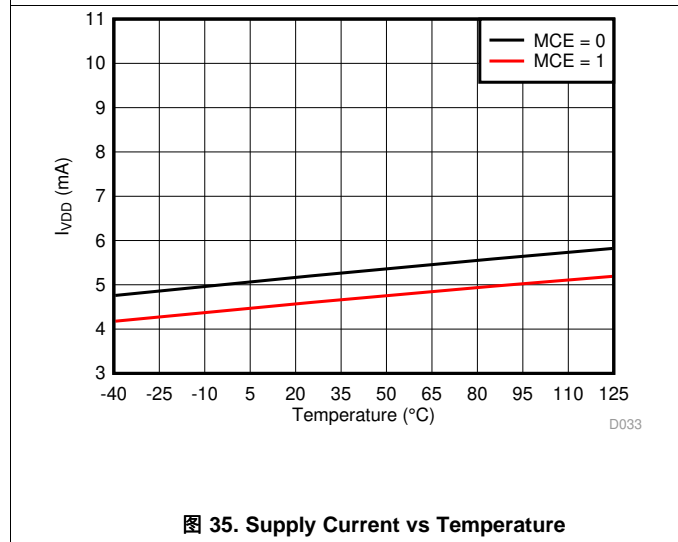
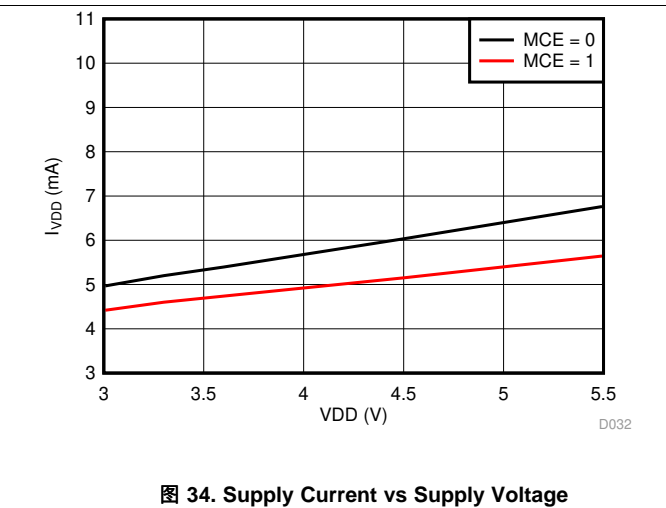
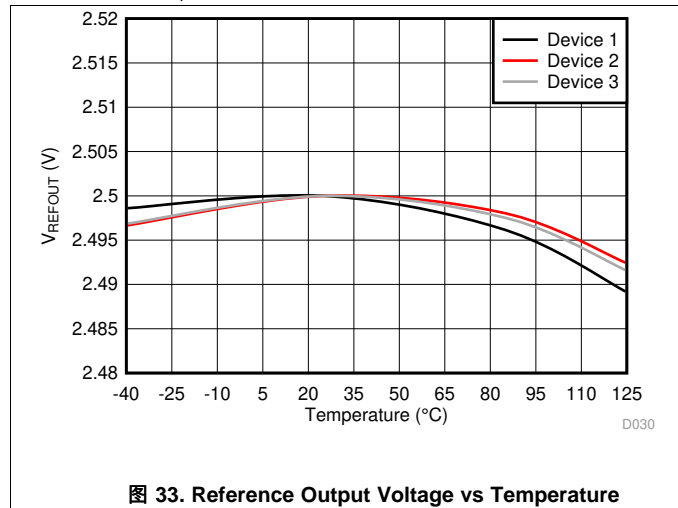

7 Detailed Description

7.1 Overview

The differential analog input (comprised of input signals AINP and AINN) of the AMC1035 is a chopper-stabilized buffer, followed by the switched-capacitor input of a second-order, delta-sigma ($\Delta\Sigma$) modulator stage that digitizes the input signal into a 1-bit output stream. The data output DOUT of the converter provides a stream of digital ones and zeros that is synchronous to the externally-provided clock source at the CLKIN pin with a frequency in the range of 9 MHz to 21 MHz. The time average of this serial bitstream output is proportional to the analog input voltage.

The [Functional Block Diagram](#) section shows a detailed block diagram of the AMC1035. The 1.6-G Ω differential input resistance of the analog input stage supports low gain-error signal sensing in high-voltage applications using resistive dividers. The external clock input simplifies the synchronization of multiple measurement channels on the system level. The extended frequency range of up to 21 MHz supports higher performance levels compared to the other solutions available on the market.

7.2 Functional Block Diagram

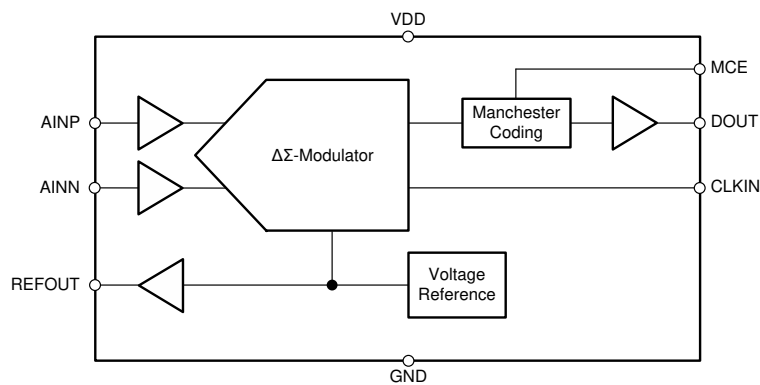

7.3 Feature Description

7.3.1 Analog Input

The AMC1035 incorporates front-end circuitry that contains a buffered sampling stage, followed by a $\Delta\Sigma$ modulator. To support a bipolar input range, the device uses a charge pump that allows single-supply operation to simplify the overall system design and minimize the circuit cost. For reduced offset and offset drift, the input buffer is chopper-stabilized with the switching frequency set at $f_{CLKIN} / 32$. [图 37](#) shows the spur created by the switching frequency.

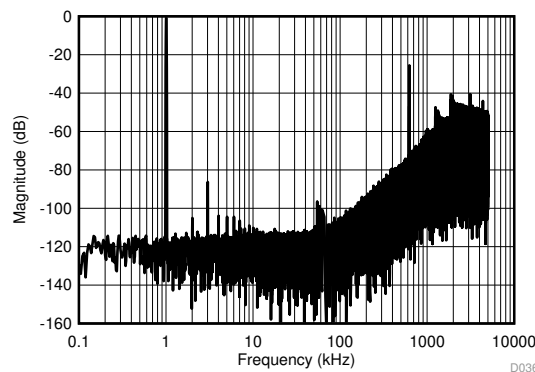

sinc^3 filter, $\text{OSR} = 2$, $f_{CLKIN} = 20 \text{ MHz}$, $f_{IN} = 1 \text{ kHz}$

图 37. Quantization Noise Shaping

Feature Description (接下页)

The linearity and noise performance of the device are ensured only when the differential analog input voltage remains within the specified linear full-scale range (FSR), that is ± 1 V, and within the specified input common-mode range.

图 38 shows the specified common-mode input voltage that applies for the full-scale input voltage range as specified in this document along with the corresponding common-mode undervoltage and overvoltage threshold levels.

If smaller input signals are used, the operational common-mode input voltage range widens. 图 39 shows the common-mode input voltage that applies with no differential input signal; that is, when the voltage applied on AINP is equal to the voltage applied on AINN. The common-mode input voltage range scales with the actual differential input voltage between this range and the range in 图 38.

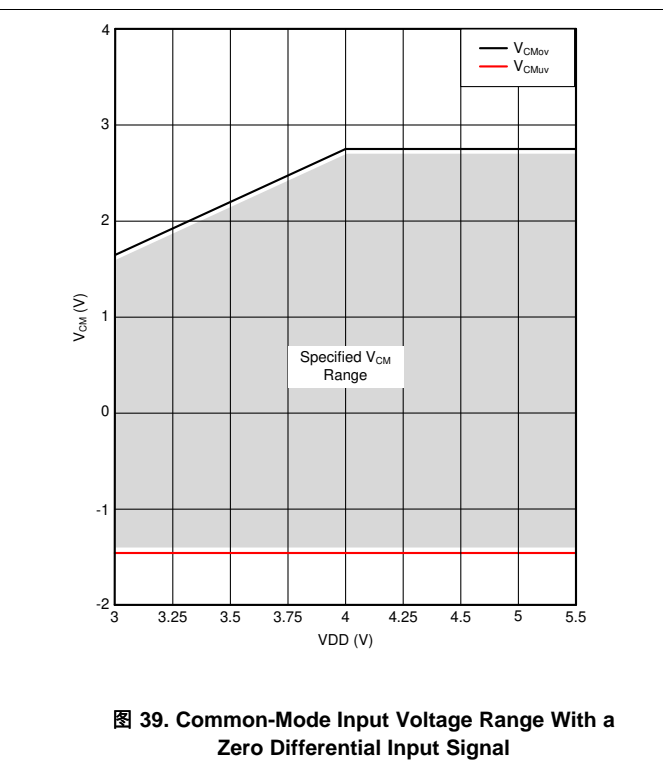
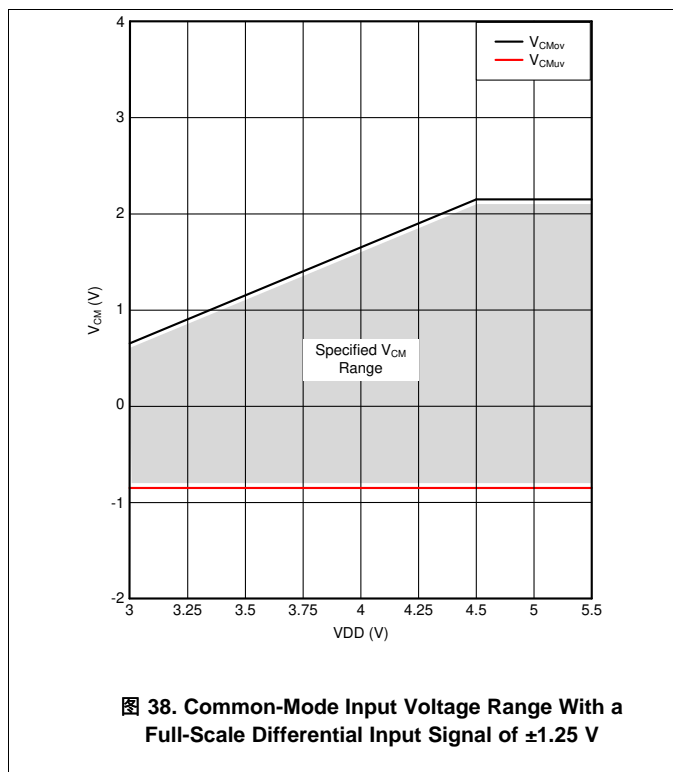

Feature Description (接下页)

7.3.2 Modulator

The modulator implemented in the AMC1035 (such as the one conceptualized in 图 40) is a second-order, switched-capacitor, feed-forward $\Delta\Sigma$ modulator. The analog input voltage V_{IN} and the output V_5 of the 1-bit digital-to-analog converter (DAC) are subtracted, providing an analog voltage V_1 at the input of the first integrator stage. The output of the first integrator feeds the input of the second integrator stage, resulting in output voltage V_3 that is summed with the input signal V_{IN} and the output of the first integrator V_2 . Depending on the polarity of the resulting voltage V_4 , the output of the comparator is changed. In this case, the 1-bit DAC responds on the next clock pulse by changing the associated analog output voltage V_5 , causing the integrators to progress in the opposite direction and forcing the value of the integrator output to track the average value of the input.



图 40. Block Diagram of a Second-Order Modulator

As depicted in 图 37, the modulator shifts the quantization noise to high frequencies. Therefore, use a low-pass digital filter at the output of the device to increase the overall performance. This filter is also used to convert from the 1-bit data stream at a high sampling rate into a higher-bit data word at a lower rate (decimation). TI's microcontroller families TMS320F28004x, TMS320F2807x, and TMS320F2837x offer a suitable programmable, hardwired filter structure termed a *sigma-delta filter module* (SDFM) optimized for usage with the AMC1035. Also, SD24_B converters on the MSP430F677x microcontrollers offer a path to directly access the integrated sinc-filters for a simple system-level solution for multichannel, isolated current sensing. An additional option is to use a suitable application-specific device, such as the AMC1210 (a four-channel digital sinc filter). Alternatively, a field-programmable gate array (FPGA) can be used to implement the filter.

7.3.3 Reference Output

The AMC1035 offers a voltage reference output that can source or sink current to significantly reduce the gain error thermal drift in ratiometric applications as specified in the [Electrical Characteristics](#) table. The [IGBT Temperature Sensing](#) section provides an example of a ratiometric use case for the AMC1035.

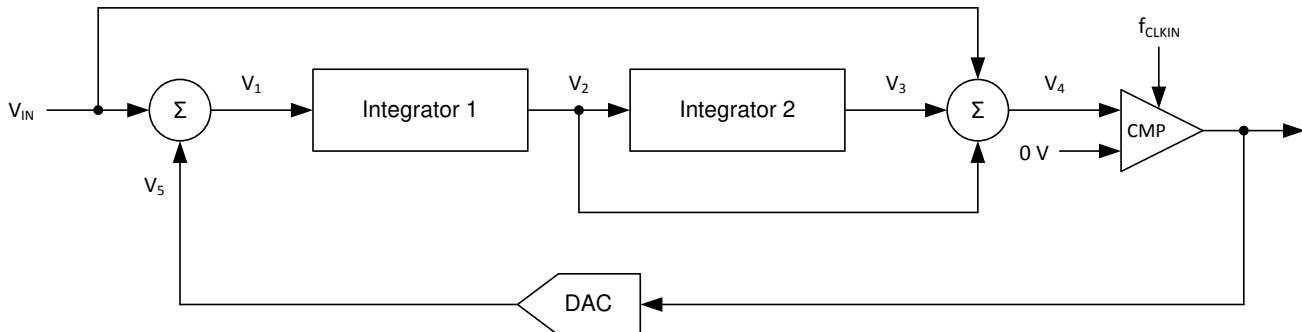
The reference output can drive capacitive loads less than 1 nF. Use a series resistor to avoid oscillations and degradation of performance for capacitive loads ≥ 1 nF. 表 1 lists the recommended series resistor values for given capacitor value examples. Interpolate for capacitive loads with a value between the given examples.

表 1. Series Resistor Value for Capacitive Loads ≥ 1 nF on REFOUT Pin

CAPACITIVE LOAD ON REFOUT PIN	1 nF	3.3 nF	10 nF	33 nF	100 nF	330 nF	1 μ F	3.3 μ F	10 μ F
Recommended series resistor	33 Ω	56 Ω	47 Ω	33 Ω	15 Ω	10 Ω	5.6 Ω	3.3 Ω	1.8 Ω

7.3.4 Clock Input

The AMC1035 system clock is provided externally at the CLKIN pin. The clock signal must be applied continuously for proper device operation.

To support the bipolar input voltage range with a single supply, the AMC1035 includes a charge pump. This charge pump stops operating if the clock signal is below the specified frequency range or if the signal is paused or missing. Additionally, the input bias current increases beyond the specified range and significantly reduces the input resistance of the device. When the clock signal is paused or missing, the modulator stops the analog signal conversion and the digital output signal remains frozen in the last logic state. When the clock signal is applied again after a pause, the internal analog circuitry biasing must settle for proper device performance. In this case, consider the t_{ASTART} specification in the [Switching Characteristics](#) table.

7.3.5 Digital Output

A differential input signal of 0 V ideally produces a stream of ones and zeros that are high 50% of the time. A differential input of 1 V produces a stream of ones and zeros that are high 90% of the time. With 16 bits of resolution, that percentage ideally corresponds to code 58982 (an unsigned code). A differential input of –1 V produces a stream of ones and zeros that are high 10% of the time and ideally results in code 6553 with 16-bit resolution. These input voltages are also the specified linear range of the AMC1035 with performance as specified in this document. If the input voltage value exceeds this range, the output of the modulator shows nonlinear behavior when the quantization noise increases. The output of the modulator clips with a stream of only zeros with an input less than or equal to –1.25 V or with a stream of only ones with an input greater than or equal to 1.25 V. In this case, however, the AMC1035 generates a single 1 (if the input is at negative full-scale) or 0 every 128 clock cycles to indicate proper device function (see the [Fail-Safe Output](#) section for more details). [图 41](#) shows the input voltage versus the output modulator signal.



图 41. Analog Input versus the AMC1035 Modulator Output

公式 1 计算了输出比特流中 1 的密度，适用于任何输入电压值（除全量程输入信号外，如 [Output Behavior in Case of a Full-Scale Input](#) 节所述）：

$$\frac{V_{\text{IN}} + V_{\text{Clipping}}}{2 \times V_{\text{Clipping}}} \quad (1)$$

调制器比特流在 DOUT 引脚随着施加在 CLKIN 引脚的时钟信号上升沿而变化。使用时钟的上升沿来锁存调制器比特流，以便在数字滤波器设备的输入处。

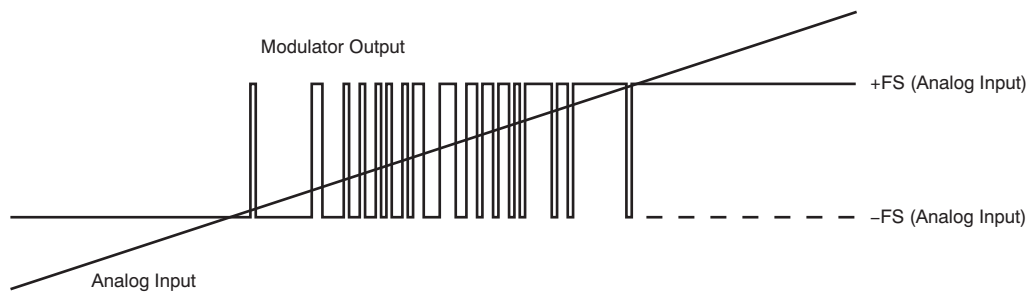
7.3.6 Manchester Coding Feature

The AMC1035 offers the IEEE 802.3-compliant Manchester coding feature that generates at least one transition per bit to support clock signal recovery from the bitstream. The Manchester coding combines the clock and data information using exclusive-OR (XOR) logical operation that results in a bitstream free of DC components. [图 42](#) shows the resulting bitstream from this coding. The duty cycle of the Manchester encoded bitstream depends on the duty cycle of the input clock CLKIN. To enable Manchester coding on the AMC1035, pull the input pin MCE high. The DOUT signal is inverted if the MCE status changes when CLKIN is high.



图 42. Manchester Coded Output of the AMC1035

7.4 Device Functional Modes

The AMC1035 is operational when the power supply VDD and clock signal CLKIN are applied, as specified in [图 39](#) and the [Switching Characteristics](#) table.

7.4.1 Output Behavior in Case of a Full-Scale Input

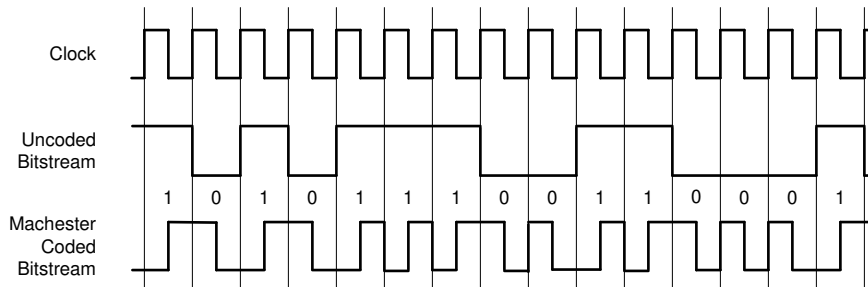
If a full-scale input signal is applied to the AMC1035 (that is, $|V_{IN}| \geq |V_{Clipping}|$), the device generates a single one or zero every 128 bits at DOUT, as shown in [图 43](#), depending on the actual polarity of the signal being sensed. This feature is also supported with Manchester-coded output and allows full-scale and invalid input signals to be identified as described in the [Fail-Safe Output](#) section and can be used for advanced system-level diagnostics.



图 43. Overrange Output of the AMC1035

Device Functional Modes (接下页)

7.4.2 Fail-Safe Output

图 44 显示了如果输入的共同模式电压达到或超过指定的共同模式欠电压, V_{CMUV} , 或过电压检测水平, V_{CMOV} 如定义在 *Electrical Characteristics* 表中, 则 AMC1035 的 DOUT 保持在稳态高电平。

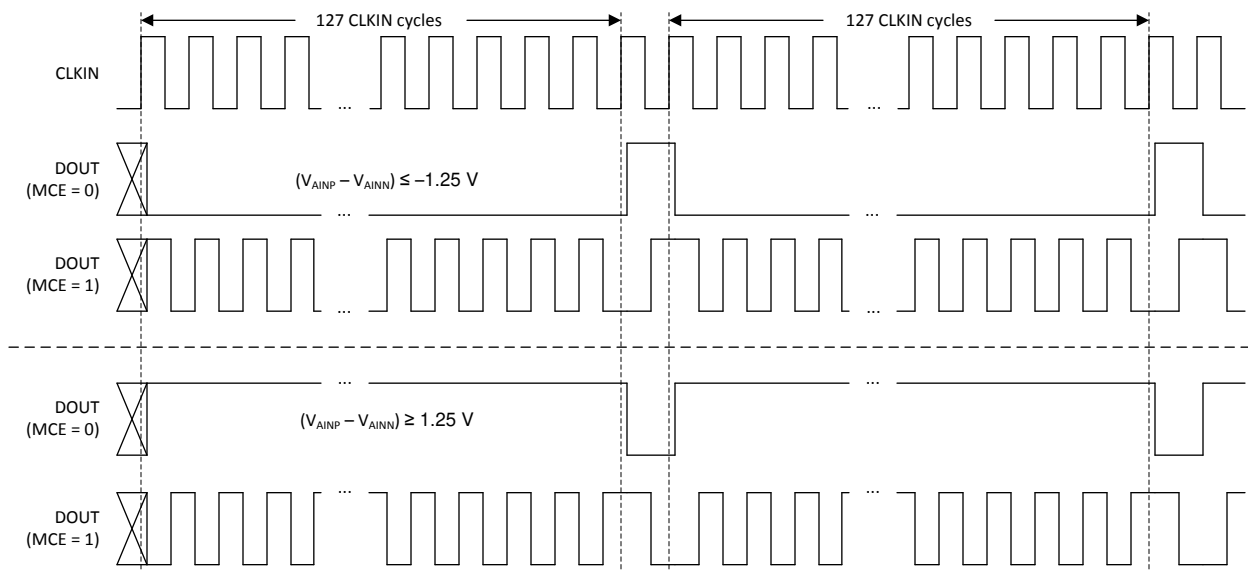

图 44. Fail-Safe Output of the AMC1035

8 Application and Implementation

注

Information in the following applications sections is not part of the TI component specification, and TI does not warrant its accuracy or completeness. TI's customers are responsible for determining suitability of components for their purposes. Customers should validate and test their design implementation to confirm system functionality.

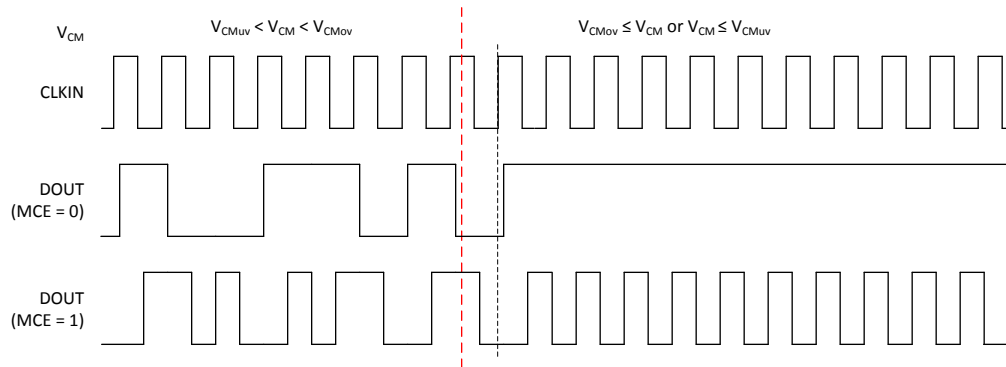
8.1 Application Information

8.1.1 Digital Filter Usage

The modulator generates a bitstream that is processed by a digital filter to obtain a digital word similar to a conversion result of a conventional analog-to-digital converter (ADC). 公式 2 显示了一个 sinc^3 -type 滤波器, 这是一个非常简单的滤波器, 构建所需的硬件最少:

$$H(z) = \left(\frac{1 - z^{-OSR}}{1 - z^{-1}} \right)^3 \quad (2)$$

此滤波器在最低硬件尺寸 (数字门计数) 的情况下为二阶调制器提供最佳输出性能。本文档中的所有表征也是使用 sinc^3 滤波器与 256 的过采样率 (OSR) 和 16 位的输出字宽。

在 FPGA 中实现 sinc^3 滤波器的示例代码在 *Combining the ADS1202 with an FPGA Digital Filter for Current Measurement in Motor Control Applications* 应用笔记中进行了讨论, 可在 www.ti.com 上下载。

8.2 Typical Applications

8.2.1 Voltage Sensing

$\Delta\Sigma$ modulators are widely used in frequency inverter designs because of their high AC and DC performance. Frequency inverters are critical parts of industrial motor drives, photovoltaic inverters (string and central inverters), uninterruptible power supplies (UPS), and other industrial applications.

Figure 45 shows a simplified schematic of a motor drive application with the AMC1035 used for the DC-link and output phase voltage sensing. In this example, all resistive dividers reference to the negative DC-link voltage that is also used as a ground reference point for the microcontroller. An additional fifth AMC1035 can be used for temperature sensing of the insulated-gate bipolar transistor (IGBT) module; see the [IGBT Temperature Sensing](#) section for more details.

Current feedback is performed with shunt resistors (R_{SHUNT}) and TI's [AMC1306M25](#) isolated modulators. Depending on the system design, either all three or only two motor phase currents are sensed.

Depending on the overall digital processing power requirements and with a total of eight $\Delta\Sigma$ modulator bitstreams to be processed by the MCU, a derivate from either the low-cost single-core [TMS320F2807x](#) or the dual-core [TMS320F2837x](#) families can be used in this application.



图 45. The AMC1035 in a Frequency Inverter Application

Typical Applications (接下页)

8.2.1.1 Design Requirements

表 2 lists the parameters for this typical application.

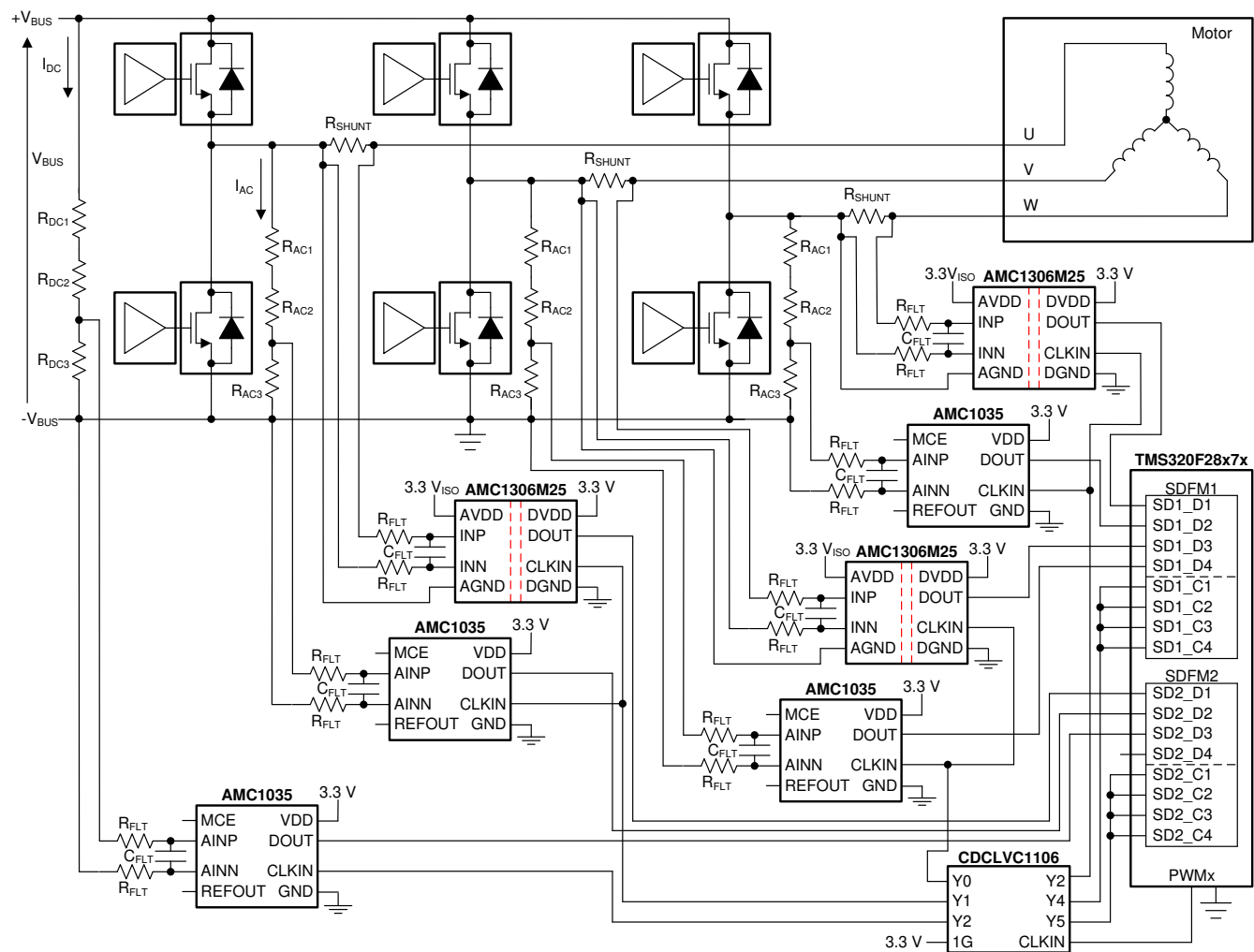
表 2. Design Requirements

PARAMETER	VALUE
Supply voltage	3.3 V
Voltage drop across the sensing resistor R_{DC1} for a linear response	1 V (maximum)
Voltage drop across the sensing resistors R_{ACx} for a linear response	± 1 V (maximum)
Current through the sensing resistors R_{ACx}	± 100 μ V (maximum)

8.2.1.2 Detailed Design Procedure

Use Ohm's Law to calculate the minimum total resistance of the resistive dividers to limit the cross current to the desired values:

- For the voltage sensing on the DC bus: $R_{DC1} + R_{DC2} + R_{DC3} = V_{BUS} / I_{DC}$
- For the voltage sensing on the output phases U, V, and W: $R_{AC1} + R_{AC2} + R_{AC3} = V_{PHASE (max)} / I_{AC}$

Consider the following two restrictions to choose the proper value of the resistors R_{DC3} and R_{AC3} :

- The voltage drop caused by the nominal voltage range of the system must not exceed the recommended input voltage range of the AMC1035: $V_{XC3} \leq V_{FSR}$
- The voltage drop caused by the maximum allowed system overvoltage must not exceed the input voltage that causes a clipping output: $V_{XC3} \leq V_{Clipping}$

Use similar approach for calculation of the shunt resistor values R_{SHUNT} and see the [AMC1306M25 data sheet](#) for further details.

表 3 lists examples of nominal E96-series (1% accuracy) resistor values for systems using 600 V and 800 V on the DC bus.

表 3. Resistor Value Examples for DC Bus Sensing

PARAMETER	600-V DC BUS	800-V DC Bus
Resistive divider resistor R_{DC1}	3.01 M Ω	4.22 M Ω
Resistive divider resistor R_{DC2}	3.01 M Ω	4.22 M Ω
Sense resistor R_{DC3}	10 k Ω	10.5 k Ω
Resulting current through resistive divider I_{DC}	99.5 μ A	94.7 μ A
Resulting voltage drop on sense resistor V_{RDC3}	0.995 V	0.994 V

表 4 lists examples of nominal E96-series (1% accuracy) resistor values for systems using 230 V and 690 V on the output phases.

表 4. Resistor Value Examples for Output Phase Voltage Sensing

PARAMETER	± 400 -V _{AC} PHASE	± 690 -V _{AC} PHASE
Resistive divider resistor R_{AC1}	2.0 M Ω	3.48 M Ω
Resistive divider resistor R_{AC2}	2.0 M Ω	3.48 M Ω
Sense resistor R_{AC3}	10.0 k Ω	10.0 k Ω
Resulting current through resistive divider I_{AC}	99.8 μ A	99.0 μ A
Resulting voltage drop on sense resistor V_{RAC3}	± 0.998 V	± 0.990 V

Use a power supply with a nominal voltage of 3.3 V to directly connect all modulators to the microcontroller.

For modulator output bitstream filtering, a device from TI's [TMS320F2807x](#) family of low-cost microcontrollers (MCUs) or [TMS320F2837x](#) family of dual-core MCUs is recommended. These MCU families support up to eight channels of dedicated hardwired filter structures called sigma-delta filter modules (SDFMs) that significantly simplify system level design by offering two filtering paths per channel: one providing high accuracy results for the control loop and one that offers a fast response path for overcurrent detection. Use one of the pulse-width modulation (PWM) sources inside the MCU to generate the clock for the modulators and for easy synchronization of all feedback signals and the switching control of the gate drivers.

[图 45](#) uses a clock buffer to distribute the clock reference signal generated on one of the PWM outputs of the MCU (called PWMx in [图 45](#)) to all modulators used in the circuit and as a reference for the digital filters in the MCU. In this example, TI's [CDCLVC1106](#) is used for this purpose. Each CDCLVC1106 output can drive a load of 8 pF that is sufficient to drive up to two modulator and up to four SDFM clock inputs.

8.2.1.3 Application Curve

The effective number of bits (ENOB) is often used to compare the performance of ADCs and $\Delta\Sigma$ modulators. [图 46](#) shows the ENOB of the AMC1035 with different oversampling ratios on a sinc3 filter. This number is calculated from the SINAD by using [公式 3](#) in this document.

$$\text{SINAD} = 1.76 \text{ dB} + 6.02 \text{ dB} \times \text{ENOB} \tag{3}$$

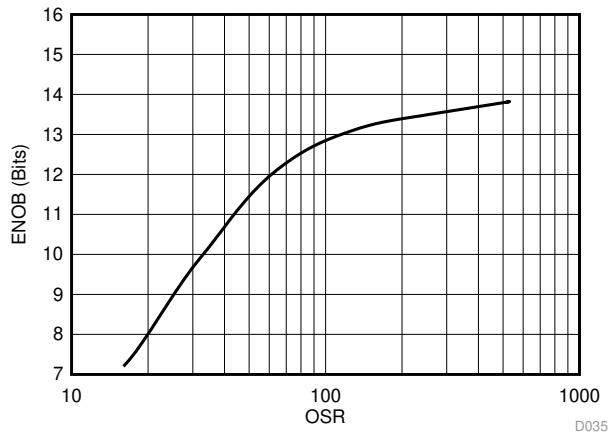

Sinc3 filter

图 46. Measured Effective Number of Bits vs Oversampling Ratio

8.2.2 IGBT Temperature Sensing

The high input impedance of the AMC1035 is optimized for usage in voltage-sensing applications. Additionally, the internal voltage reference supports temperature sensing using a positive temperature coefficient (PTC) or a negative temperature coefficient (NTC) sensor often integrated in the IGBT module.

The same reference is internally used by the modulator, resulting in a ratiometric system solution that minimizes the overall temperature drift of the sensing path. 图 47 shows a simplified schematic of the AMC1035 used for temperature sensing of the IGBT module.



图 47. Using the AMC1035 for Temperature Sensing

8.2.3 What to Do and What Not to Do

Do not leave the analog inputs of the AMC1035 unconnected (floating) when the device is powered up. If either modulator input is left floating, the input bias current may drive this input beyond the specified common-mode input voltage range. If both inputs are beyond that range, the gain of the front-end diminishes. In both cases, the modulator outputs a fail-safe bitstream as described in the [Fail-Safe Output](#) section.

9 Power Supply Recommendations

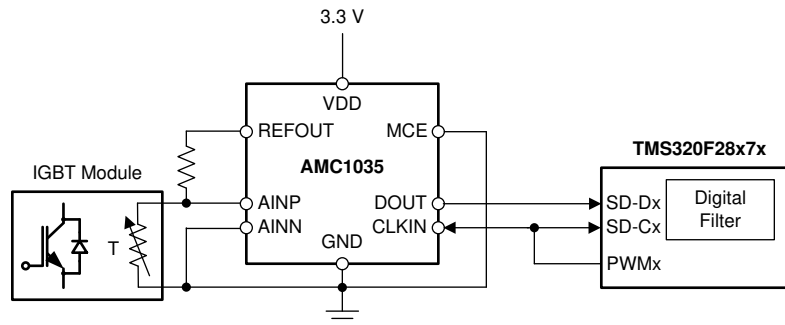
For decoupling of the power supply, a 0.1- μF capacitor is recommended to be placed as close to the VDD pin of the AMC1035 as possible, as shown in [图 48](#), followed by an additional capacitor in the range of 1 μF to 10 μF .



图 48. Decoupling the AMC1035

Safety considerations or high common-mode voltage levels may require the AMC1035 to be galvanically isolated from other parts of the system. [图 49](#) shows an example of a circuit that uses the [ISO7721](#) to isolate the signal path and the SN6501 and a transformer to generate the required isolated power.

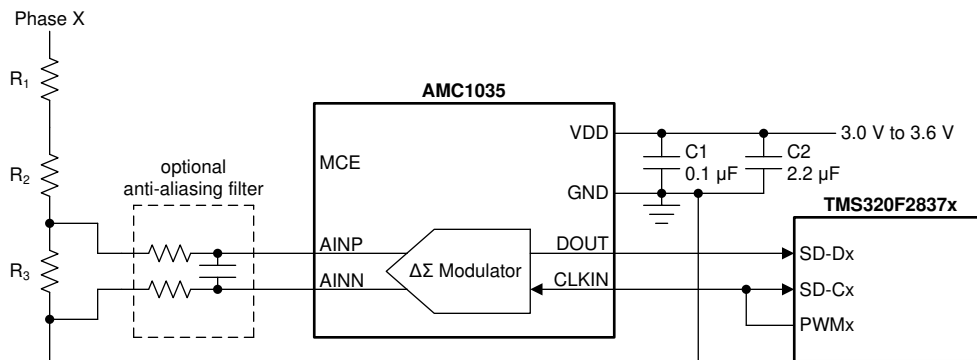

图 49. Galvanic Isolation of the AMC1035

[图 50](#) shows an alternative solution that uses the [ISOW7821](#) to isolate the signal path and provide the isolated power supply for the AMC1035.

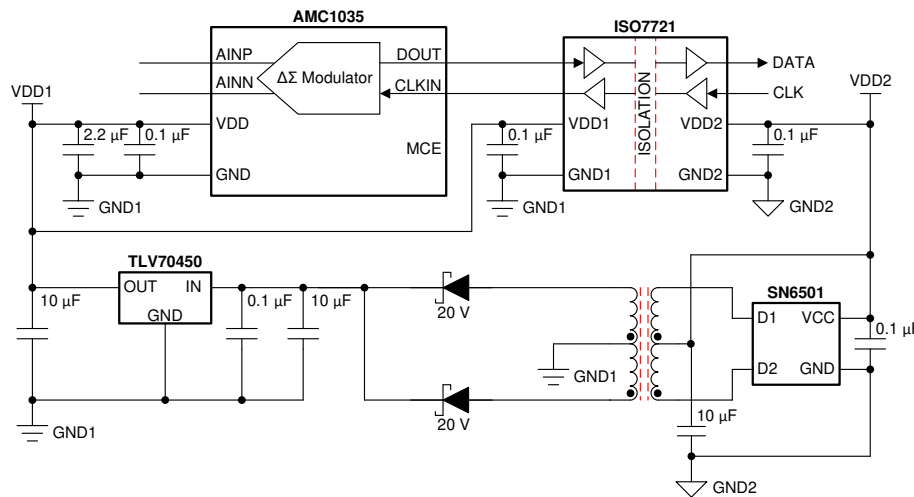

图 50. Galvanic Isolation of the AMC1035 for PCB Space-Constrained Applications

10 Layout

10.1 Layout Guidelines

图 51 shows two layout recommendations for designs based on 1206-SMD or 0603-SMD size decoupling capacitors placed as close as possible to the AMC1035. For best performance, place the AMC1035 as close as possible to the source of the analog signal to be converted and keep the layout of the AINP and AINN traces symmetrical.

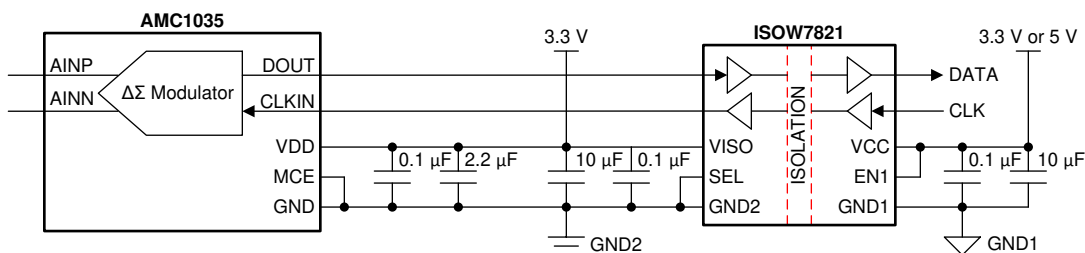
10.2 Layout Example



图 51. Recommended Layout of the AMC1035

11 器件和文档支持

11.1 文档支持

11.1.1 相关文档

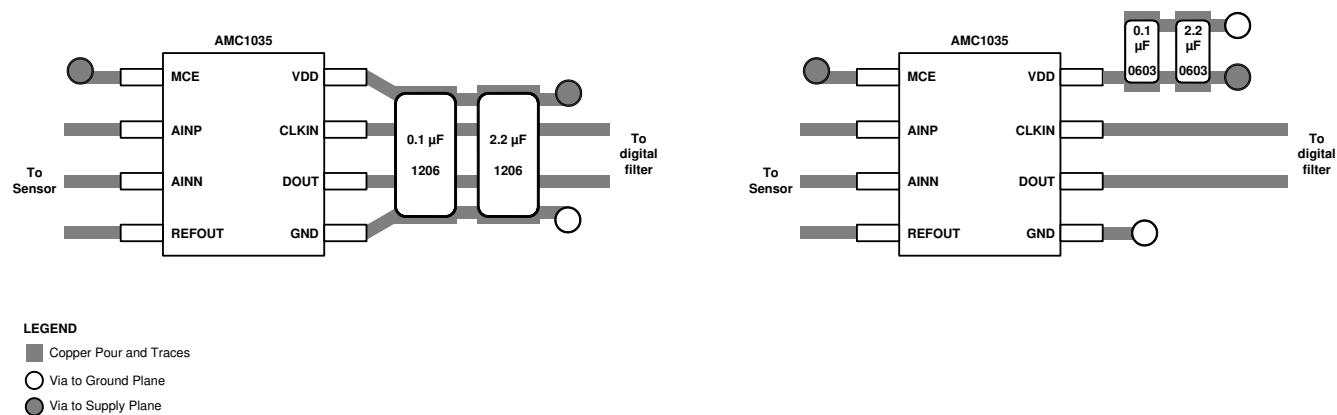
请参阅如下相关文档：

- 德州仪器 (TI), 《TMS320F28004x Piccolo™ 微控制器》数据表
- 德州仪器 (TI), 《TMS320F2807x Piccolo™ 微控制器》数据表
- 德州仪器 (TI), 《TMS320F2837xD 双核 Delfino™ 微控制器》数据表
- 德州仪器 (TI), 《具有优异 EMC 性能的 ISO772x 高速双通道数字隔离器》数据表
- 德州仪器 (TI), 《MSP430F677x 多相位仪表计量片上系统》数据表
- 德州仪器 (TI), 《适用于二阶 Δ - Σ 调制器的 AMC1210 四路数字滤波器》数据表
- 德州仪器 (TI), 《将 ADS1202 与 FPGA 数字滤波器结合, 以便在电机控制应用中进行 电流测量》中的电流》应用报告
- 德州仪器 (TI), 《具有高 CMTI 的 AMC1306x 小型、高精度、增强型隔离式 Δ - Σ 调制器》数据表
- 德州仪器 (TI), 《CDCLVC11xx 3.3V 和 2.5V LVCMOS 高性能时钟缓冲器系列》数据表
- 德州仪器 (TI), 《LM117、LM317-N 宽温度范围三引脚可调稳压器》数据表
- 德州仪器 (TI), 《用于隔离式电源的 SN6502 低噪声 350mA 410kHz 变压器驱动器》数据表
- 德州仪器 (TI), 《具有集成式高效低辐射直流/直流转换器的 ISOW7821 高性能 5000V_{RMS} 增强型双通道数字隔离器》数据表

11.2 接收文档更新通知

要接收文档更新通知, 请导航至 ti.com.cn 上的器件产品文件夹。单击右上角的通知我进行注册, 即可每周接收产品信息更改摘要。有关更改的详细信息, 请查看任何已修订文档中包含的修订历史记录。

11.3 社区资源

TI E2E™ support forums are an engineer's go-to source for fast, verified answers and design help — straight from the experts. Search existing answers or ask your own question to get the quick design help you need.

Linked content is provided "AS IS" by the respective contributors. They do not constitute TI specifications and do not necessarily reflect TI's views; see TI's [Terms of Use](#).

11.4 商标

E2E is a trademark of Texas Instruments.

All other trademarks are the property of their respective owners.

11.5 静电放电警告



ESD 可能会损坏该集成电路。德州仪器 (TI) 建议通过适当的预防措施处理所有集成电路。如果不遵守正确的处理措施和安装程序, 可能会损坏集成电路。

ESD 的损坏小至导致微小的性能降级, 大至整个器件故障。精密的集成电路可能更容易受到损坏, 这是因为非常细微的参数更改都可能会导致器件与其发布的规格不相符。

11.6 Glossary

SLYZ022 — TI Glossary.

This glossary lists and explains terms, acronyms, and definitions.

12 机械、封装和可订购信息

以下页面包含机械、封装和可订购信息。这些信息是指定器件的最新可用数据。数据如有变更, 恕不另行通知, 且不会对此文档进行修订。如需获取此数据表的浏览器版本, 请查阅左侧的导航栏。

PACKAGING INFORMATION

Orderable Device	Status (1)	Package Type	Package Drawing	Pins	Package Qty	Eco Plan (2)	Lead finish/ Ball material (6)	MSL Peak Temp (3)	Op Temp (°C)	Device Marking (4/5)	Samples
AMC1035D	ACTIVE	SOIC	D	8	75	RoHS & Green	NIPDAU	Level-1-260C-UNLIM	-40 to 125	MC1035	Samples
AMC1035DR	ACTIVE	SOIC	D	8	2500	RoHS & Green	NIPDAU	Level-1-260C-UNLIM	-40 to 125	MC1035	Samples

(1) The marketing status values are defined as follows:

ACTIVE: Product device recommended for new designs.

LIFEBUY: TI has announced that the device will be discontinued, and a lifetime-buy period is in effect.

NRND: Not recommended for new designs. Device is in production to support existing customers, but TI does not recommend using this part in a new design.

PREVIEW: Device has been announced but is not in production. Samples may or may not be available.

OBSOLETE: TI has discontinued the production of the device.

(2) **RoHS:** TI defines "RoHS" to mean semiconductor products that are compliant with the current EU RoHS requirements for all 10 RoHS substances, including the requirement that RoHS substance do not exceed 0.1% by weight in homogeneous materials. Where designed to be soldered at high temperatures, "RoHS" products are suitable for use in specified lead-free processes. TI may reference these types of products as "Pb-Free".

RoHS Exempt: TI defines "RoHS Exempt" to mean products that contain lead but are compliant with EU RoHS pursuant to a specific EU RoHS exemption.

Green: TI defines "Green" to mean the content of Chlorine (Cl) and Bromine (Br) based flame retardants meet JS709B low halogen requirements of <=1000ppm threshold. Antimony trioxide based flame retardants must also meet the <=1000ppm threshold requirement.

(3) MSL, Peak Temp. - The Moisture Sensitivity Level rating according to the JEDEC industry standard classifications, and peak solder temperature.

(4) There may be additional marking, which relates to the logo, the lot trace code information, or the environmental category on the device.

(5) Multiple Device Markings will be inside parentheses. Only one Device Marking contained in parentheses and separated by a "~" will appear on a device. If a line is indented then it is a continuation of the previous line and the two combined represent the entire Device Marking for that device.

(6) Lead finish/Ball material - Orderable Devices may have multiple material finish options. Finish options are separated by a vertical ruled line. Lead finish/Ball material values may wrap to two lines if the finish value exceeds the maximum column width.

Important Information and Disclaimer:The information provided on this page represents TI's knowledge and belief as of the date that it is provided. TI bases its knowledge and belief on information provided by third parties, and makes no representation or warranty as to the accuracy of such information. Efforts are underway to better integrate information from third parties. TI has taken and continues to take reasonable steps to provide representative and accurate information but may not have conducted destructive testing or chemical analysis on incoming materials and chemicals. TI and TI suppliers consider certain information to be proprietary, and thus CAS numbers and other limited information may not be available for release.

In no event shall TI's liability arising out of such information exceed the total purchase price of the TI part(s) at issue in this document sold by TI to Customer on an annual basis.

TAPE AND REEL INFORMATION

QUADRANT ASSIGNMENTS FOR PIN 1 ORIENTATION IN TAPE



*All dimensions are nominal

Device	Package Type	Package Drawing	Pins	SPQ	Reel Diameter (mm)	Reel Width W1 (mm)	A0 (mm)	B0 (mm)	K0 (mm)	P1 (mm)	W (mm)	Pin1 Quadrant
AMC1035DR	SOIC	D	8	2500	330.0	12.4	6.4	5.2	2.1	8.0	12.0	Q1

TAPE AND REEL BOX DIMENSIONS

*All dimensions are nominal

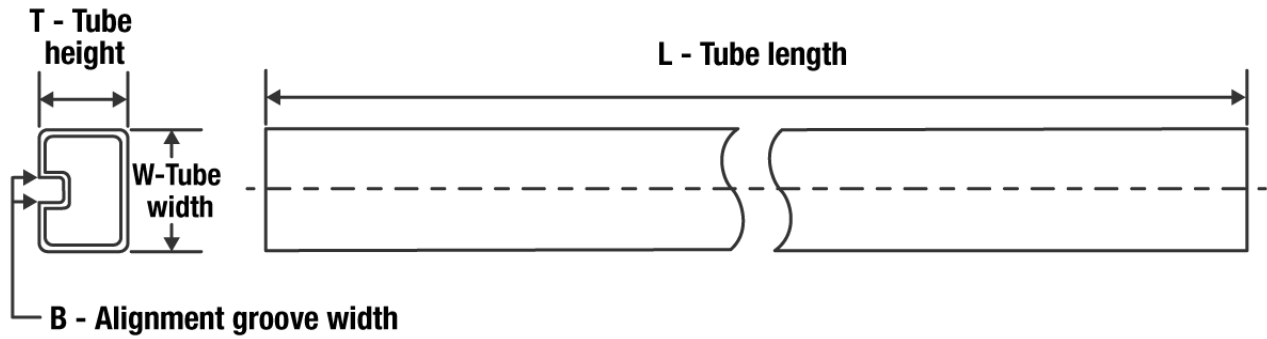
Device	Package Type	Package Drawing	Pins	SPQ	Length (mm)	Width (mm)	Height (mm)
AMC1035DR	SOIC	D	8	2500	340.5	336.1	25.0

TUBE

*All dimensions are nominal

Device	Package Name	Package Type	Pins	SPQ	L (mm)	W (mm)	T (μm)	B (mm)
AMC1035D	D	SOIC	8	75	507	8	3940	4.32



D0008A

PACKAGE OUTLINE

SOIC - 1.75 mm max height

SMALL OUTLINE INTEGRATED CIRCUIT



4214825/C 02/2019

NOTES:

- Linear dimensions are in inches [millimeters]. Dimensions in parenthesis are for reference only. Controlling dimensions are in inches. Dimensioning and tolerancing per ASME Y14.5M.
- This drawing is subject to change without notice.
- This dimension does not include mold flash, protrusions, or gate burrs. Mold flash, protrusions, or gate burrs shall not exceed $.006$ [0.15] per side.
- This dimension does not include interlead flash.
- Reference JEDEC registration MS-012, variation AA.

EXAMPLE BOARD LAYOUT

D0008A

SOIC - 1.75 mm max height

SMALL OUTLINE INTEGRATED CIRCUIT



LAND PATTERN EXAMPLE
EXPOSED METAL SHOWN
SCALE:8X



SOLDER MASK DETAILS

4214825/C 02/2019

NOTES: (continued)

6. Publication IPC-7351 may have alternate designs.

7. Solder mask tolerances between and around signal pads can vary based on board fabrication site.

EXAMPLE STENCIL DESIGN

D0008A

SOIC - 1.75 mm max height

SMALL OUTLINE INTEGRATED CIRCUIT



SOLDER PASTE EXAMPLE
BASED ON .005 INCH [0.125 MM] THICK STENCIL
SCALE:8X

4214825/C 02/2019

NOTES: (continued)

8. Laser cutting apertures with trapezoidal walls and rounded corners may offer better paste release. IPC-7525 may have alternate design recommendations.
9. Board assembly site may have different recommendations for stencil design.

重要声明和免责声明

TI“按原样”提供技术和可靠性数据（包括数据表）、设计资源（包括参考设计）、应用或其他设计建议、网络工具、安全信息和其他资源，不保证没有瑕疵且不做任何明示或暗示的担保，包括但不限于对适销性、某特定用途方面的适用性或不侵犯任何第三方知识产权的暗示担保。

这些资源可供使用 TI 产品进行设计的熟练开发人员使用。您将自行承担以下全部责任：(1) 针对您的应用选择合适的 TI 产品，(2) 设计、验证并测试您的应用，(3) 确保您的应用满足相应标准以及任何其他功能安全、信息安全、监管或其他要求。

这些资源如有变更，恕不另行通知。TI 授权您仅可将这些资源用于研发本资源所述的 TI 产品的应用。严禁对这些资源进行其他复制或展示。您无权使用任何其他 TI 知识产权或任何第三方知识产权。您应全额赔偿因在这些资源的使用中对 TI 及其代表造成的任何索赔、损害、成本、损失和债务，TI 对此概不负责。

TI 提供的产品受 [TI 的销售条款](#) 或 [ti.com](#) 上其他适用条款/TI 产品随附的其他适用条款的约束。TI 提供这些资源并不会扩展或以其他方式更改 TI 针对 TI 产品发布的适用的担保或担保免责声明。

TI 反对并拒绝您可能提出的任何其他或不同的条款。

邮寄地址：Texas Instruments, Post Office Box 655303, Dallas, Texas 75265

Copyright © 2022，德州仪器 (TI) 公司