

带有电源路径管理的 **2.5A**，单输入、单节开关模式锂离子电池充电器

查询样品: **bq24278**

特性

- 具有独立电源路径控制的高效开关模式充电器
 - 从深度放电电池或者在无电池的情况下快速启动系统
- 额定 **20V** 输入，带有 **10.5V** 过压保护 (**OVP**)
- 集成场效应晶体管 (**FET**) 可使充电率高达 **2.5A**
- 用于电源路径管理的高度集成电池 **N** 通道金属氧化物半导体场效应晶体管 (**MOSFET**) 控制器
- 安全且准确的电池管理功能
 - 电池调节精度 **0.5%**
 - 充电电流精度 **10%**
- 基于电压的、负温度系数热敏电阻 (**NTC**) 监控输入 (**TS**)
 - 标准温度范围

- 用于输出电流控制的热调节保护
- 低电池漏电流，**BAT** (电池) 短路保护
- 软启动特性以降低涌入电流
- 热关断和保护
- 采用小型 **49** 焊球晶圆级芯片封装 (**WCSP**) 或者四方扁平无引线 (**QFN**)-**24** 封装

应用范围

- 手持产品
- 便携式媒体播放器
- 便携式设备
- 上网本和便携式互联网器件

应用电路原理图

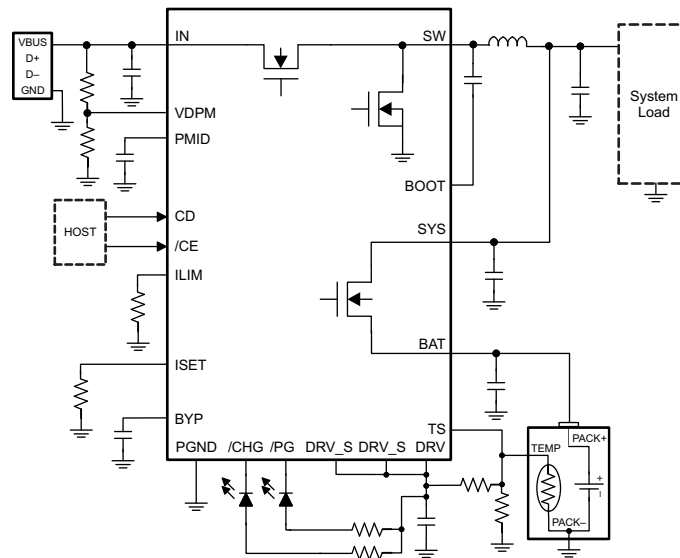

说明

bq24278 高度集成的单节锂离子电池充电器和系统电源路径管理器件针对空间有限且带有大容量电池的便携式应用。单节充电器由一个诸如 AC (交流) 适配器或者无线电源的专用充电电源供电运行。



Please be aware that an important notice concerning availability, standard warranty, and use in critical applications of Texas Instruments semiconductor products and disclaimers thereto appears at the end of this data sheet.



These devices have limited built-in ESD protection. The leads should be shorted together or the device placed in conductive foam during storage or handling to prevent electrostatic damage to the MOS gates.

说明（继续）

此电源路径管理特性使得 bq24278 能够在为电池独立充电的同时从一个高效 DC 到 DC 转换器为系统供电。此充电器一直监视电池电流并在系统负载所需电流超过输入电流限制时减少充电电流。这样可实现正常的充电终止和定时器运行。系统电压被调节至电池电压，但不会下降至低于 3.5V。最小系统电压支持使得此系统能够与一个残次品或者有缺失的电池组一起运行并且即使在电池完全放电或者无电池的情况下也可实现瞬时系统启动。当适配器不能传送峰值系统电流时，此电源路径管理架构还允许电池补充系统电流需要。这样可使用较小的适配器。

电池充电经历以下三个阶段：充电，恒定电流和恒定电压。在所有的充电阶段，一个内部控制环路监视 IC 结温并且在超过内部温度阈值的情况下减少充电电流。此外，bq24278 提供一个基于电压的电池组热敏电阻器监控输入 (TS) 来监控电池温度以保证安全充电。

ORDERING INFORMATION

PART NUMBER	IN OVP	NTC MONITORING (TS)	JEITA COMPATIBLE	MINIMUM SYSTEM VOLTAGE	PACKAGE
bq24278YFFR	10.5 V	Yes	No	3.5 V	WCSP
bq24278YFFT	10.5 V	Yes	No	3.5 V	WCSP
bq24278RGER	10.5 V	Yes	No	3.5 V	QFN
bq24278RGET	10.5 V	Yes	No	3.5 V	QFN

ABSOLUTE MAXIMUM RATINGS

over operating free-air temperature range (unless otherwise noted)⁽¹⁾

		MIN	MAX	UNIT
Pin voltage range (with respect to VSS)	IN	-2	20	V
	PMID, BYP, BOOT	-0.3	20	V
	SW	-0.7	12	V
	SYS, BAT, BGATE, DRV, $\overline{\text{PG}}$, $\overline{\text{CHG}}$, $\overline{\text{CE}}$, CD, TS, DRV_S, ILIM, ISET, VDPM	-0.3	7	V
BOOT to SW		-0.3	7	V
Output current (continuous)	SW		4.5	A
	SYS		3.5	A
Input current (continuous)	IN		2.75	A
Output sink current	$\overline{\text{PG}}$, $\overline{\text{CHG}}$		10	mA
Operating free-air temperature range		-40	85	°C
Junction temperature, T _J		-40	125	°C
Storage temperature, T _{STG}		-65	150	°C
Lead temperature (soldering, 10 s)			300	°C

- (1) Stresses beyond those listed under absolute maximum ratings may cause permanent damage to the device. These are stress ratings only, and functional operation of the device at these or any other conditions beyond those indicated under recommended operating conditions is not implied. Exposure to absolute-maximum-rated conditions for extended periods may affect device reliability. All voltage values are with respect to the network ground terminal unless otherwise noted.

THERMAL INFORMATION

THERMAL METRIC ⁽¹⁾		bq24278		UNITS
		YFF (48 PINS)	QFN (24 PINS)	
θ_{JA}	Junction-to-ambient thermal resistance	49.8	32.6	°C/W
θ_{JCTop}	Junction-to-case (top) thermal resistance	0.2	30.5	
θ_{JB}	Junction-to-board thermal resistance	1.1	3.3	
Ψ_{JT}	Junction-to-top characterization parameter	1.1	0.4	
Ψ_{JB}	Junction-to-board characterization parameter	6.6	9.3	
θ_{JCbott}	Junction-to-case (bottom) thermal resistance	N/A	2.6	

(1) 有关传统和全新热度的更多信息，请参阅 IC 封装热度量 应用报告 (文献号：SPRA953)。

RECOMMENDED OPERATING CONDITIONS

		MIN	MAX	UNITS
V_{IN}	IN voltage range	4.2	18 ⁽¹⁾	V
	IN operating range	4.2	10	
I_{IN}	Input current IN input		2.5	A
I_{SYS}	Output Current from SW, DC		3	A
I_{BAT}	Charging		2.5	A
	Discharging, using internal battery FET		2.5	
T_J	Operating junction temperature range	0	125	°C

(1) The inherent switching noise voltage spikes should not exceed the absolute maximum rating on either the BOOT or SW pins. A tight layout minimizes switching noise.

ELECTRICAL CHARACTERISTICS

Circuit of Figure 2, $V_{UVLO} < V_{IN} < V_{OVP}$ AND $V_{IN} > V_{BAT} + V_{SLP}$, $T_J = 0^\circ\text{C} - 125^\circ\text{C}$ and $T_J = 25^\circ\text{C}$ for typical values (unless otherwise noted)

PARAMETER	TEST CONDITIONS	MIN	TYP	MAX	UNIT		
I_{IN}	Input quiescent current	$V_{UVLO} < V_{IN} < V_{OVP}$ AND $V_{IN} > V_{BAT} + V_{SLP}$ PWM switching		15	mA		
		$V_{UVLO} < V_{IN} < V_{OVP}$ AND $V_{IN} > V_{BAT} + V_{SLP}$ PWM NOT switching		5			
		0°C < T_J < 85°C, High-Z Mode		175	µA		
$I_{BATLEAK}$	Leakage current from BAT to the supply	0°C < T_J < 85°C, $V_{BAT} = 4.2\text{V}$, $V_{IN} = 0\text{V}$		5	µA		
I_{BAT_HIZ}	Battery discharge current in High Impedance mode (BAT, SW, SYS)	0°C < T_J < 85°C, $V_{BAT} = 4.2\text{V}$, $V_{IN} = 0\text{V}$ or 5V , High-Z Mode		55	µA		
POWER PATH MANAGEMENT							
$V_{SYS(REG)}$	System regulation voltage	$V_{BAT} < V_{MINSYS}$		3.6	3.7	3.82	V
$V_{SYSREGFETOFF}$		Battery FET turned off, Charge disable or termination		4.26	4.33	4.37	
V_{MINSYS}	Minimum system regulation voltage	$V_{BAT} < V_{MINSYS}$, Input current limit or VINDPM active		3.4	3.5	3.62	V
V_{BSUP1}	Enter supplement mode threshold	$V_{BAT} > 2.5\text{V}$			$V_{BAT} - 40\text{mV}$		V
V_{BSUP2}	Exit supplement mode threshold	$V_{BAT} > 2.5\text{V}$			$V_{BAT} - 10\text{mV}$		V
$I_{LIM(Discharge)}$	Current limit, discharge or supplement mode	Current monitored in internal FET only			7		A
$t_{DGL(SC1)}$	Degitch time, OUT short circuit during discharge or supplement mode	Measured from ($V_{BAT} - V_{SYS}$) = 300 mV to $V_{BGATE} = (V_{BAT} - 600\text{mV})$			250		µs
$t_{REC(SC1)}$	Recovery time, OUT short circuit during discharge or supplement mode				60		ms
	Battery range for BGATE operation			2.5		4.5	V

ELECTRICAL CHARACTERISTICS (continued)

 Circuit of , $V_{UVLO} < V_{IN} < V_{OVP}$ AND $V_{IN} > V_{BAT} + V_{SLP}$, $T_J = 0^\circ\text{C} - 125^\circ\text{C}$ and $T_J = 25^\circ\text{C}$ for typical values (unless otherwise noted)

PARAMETER		TEST CONDITIONS	MIN	TYP	MAX	UNIT	
BATTERY CHARGER							
$R_{ON(BAT-SYS)}$	Internal battery charger MOSFET on-resistance	Measured from BAT to SYS, $V_{BAT} = 4.2\text{ V}$	YFF pkg	37	57	mΩ	
			RGE pkg	50	70		
V_{BATREG}	Battery regulation voltage	$T_A = 25^\circ\text{C}$		4.179	4.2	4.221	V
		$V_{WARM} < V_{TS} < V_{COOL}$		4.160	4.2	4.24	
		$T_A = 25^\circ\text{C}$		4.04	4.06	4.08	
		$V_{HOT} < V_{TS} < V_{WARM}$		4.02	4.06	4.1	
I_{CHARGE}	Charge current programmable range	$I_{CHARGE} = \frac{K_{ISET}}{R_{ISET}}$		550	2500	mA	
K_{ISET}	Programmable fast charge current factor	$T_A = 0^\circ\text{C}$ to 125°C , $V_{WARM} < V_{TS} < V_{COOL}$		400	490	560	AΩ
		$T_A = 0^\circ\text{C}$ to 125°C , $V_{COLD} < V_{TS} < V_{COOL}$		225	245	270	
$V_{BATSHRT}$	Battery short threshold	V_{BAT} Rising		2.9	3.0	3.1	V
$V_{BATSHRT_{HYS}}$	Battery short threshold hysteresis	V_{BAT} Falling		100			mV
$I_{BATSHRT}$	Battery short current	$V_{BAT} < V_{BATSHRT}$		50.0			mA
$t_{DGL(BATSHRT)}$	Deglitch time for battery short to fast charge transition				32		ms
I_{TERM}	Termination charge current	$I_{CHARGE} \leq 1\text{ A}$		7	10	11.5	% I_{CHARGE}
		$I_{CHARGE} > 1\text{ A}$		8	10	11	
$t_{DGL(TERM)}$	Deglitch time for charge termination	Both rising and falling, 2-mV over-drive, $t_{RISE}, t_{FALL} = 100\text{ ns}$			32		ms
V_{RCH}	Recharge threshold voltage	Below V_{BATREG}		120			mV
$t_{DGL(RCH)}$	Deglitch time	V_{BAT} falling below V_{RCH} , $t_{FALL} = 100\text{ ns}$			32		ms
I_{DETECT}	Battery detection current before charge done (sink current)			2.5			mA
t_{DETECT}	Battery detection time			250			ms
INPUT PROTECTION							
I_{INLIM}	Maximum input current limit programmable range for IN input	$I_{INLIM} = \frac{K_{ILIM}}{R_{ILIM}}$		1000	2500		mA
K_{ILIM}	Maximum input current factor for IN input			238	251	264	AΩ
$V_{IN_DPM_IN}$	VIN_DPM threshold programmable range for IN Input			4.2		10	V
	V_DPM threshold			1.18	1.2	1.22	V
V_{DRV}	Internal bias regulator voltage			5	5.2	5.45	V
I_{DRV}	DRV Output current			10			mA
V_{DO_DRV}	DRV Dropout voltage ($V_{IN} - V_{DRV}$)	$I_{IN} = 1\text{ A}$, $V_{IN} = 5\text{ V}$, $I_{DRV} = 10\text{ mA}$				450	mV
V_{UVLO}	IC active threshold voltage	V_{IN} rising		3.6	3.8	4.0	V
V_{UVLO_HYS}	IC active hysteresis	V_{IN} falling from above V_{UVLO}			150		mV
V_{SLP}	Sleep-mode entry threshold, $V_{IN} - V_{BAT}$	$2.0\text{ V} \leq V_{BAT} \leq V_{OREG}$, V_{IN} falling		0	40	100	mV
V_{SLP_EXIT}	Sleep-mode exit hysteresis	$2.0\text{ V} \leq V_{BAT} \leq V_{OREG}$		40	100	160	mV
	Deglitch time for supply rising above $V_{SLP} + V_{SLP_EXIT}$	Rising voltage, 2-mV over drive, $t_{RISE} = 100\text{ ns}$			30		ms
V_{OVP}	Input supply OVP threshold voltage	IN, V_{IN} Rising		10.3	10.5	10.7	V
$V_{OVP(HYS)}$	V_{OVP} hysteresis	Supply falling from V_{OVP}			100		mV
V_{BOVP}	Battery OVP threshold voltage	V_{BAT} threshold over V_{OREG} to turn off charger during charge		$1.025 \times V_{BATREG}$	$1.05 \times V_{BATREG}$	$1.075 \times V_{BATREG}$	V
	V_{BOVP} hysteresis	Lower limit for V_{BAT} falling from above V_{BOVP}			1		% of V_{BATREG}
$V_{BATUVLO}$	Battery UVLO threshold voltage				2.5		V
I_{LIMIT}	Cycle by Cycle current limit			4.1	4.9	5.6	A
$T_{SHUTDWN}$	Thermal shutdown	10C Hysteresis			165		C
T_{REG}	Thermal regulation threshold				120		C
	Safety Timer			324	360	396	min
\overline{CE}, \overline{CD}, \overline{PG}, \overline{CHG}							
V_{IH}	Input high threshold			1.3			V
V_{IL}	Input low threshold					0.4	V
I_{IH}	High-level leakage current	$V_{CHG} = V_{PG} = 5\text{ V}$				1	μA
V_{OL}	Low-level output saturation voltage	$I_O = 10\text{ mA}$, sink current				0.4	V
PWM CONVERTER							

ELECTRICAL CHARACTERISTICS (continued)

 Circuit of , $V_{U_{VLO}} < V_{IN} < V_{OVP}$ AND $V_{IN} > V_{BAT} + V_{SLP}$, $T_J = 0^{\circ}\text{C} - 125^{\circ}\text{C}$ and $T_J = 25^{\circ}\text{C}$ for typical values (unless otherwise noted)

PARAMETER		TEST CONDITIONS	MIN	TYP	MAX	UNIT
	Internal top reverse blocking MOSFET on-resistance	$I_{IN_LIMIT} = 500 \text{ mA}$, Measured from V_{IN} to PMIDU		95	175	mΩ
	Internal top N-channel Switching MOSFET on-resistance	Measured from PMIDU to SW		100	175	mΩ
	Internal bottom N-channel MOSFET on-resistance	Measured from SW to PGND		65	115	mΩ
f_{OSC}	Oscillator frequency		1.35	1.50	1.65	MHz
D_{MAX}	Maximum duty cycle			95%		
D_{MIN}	Minimum duty cycle		0			
BATTERY-PACK NTC MONITOR						
V_{HOT}	High temperature threshold	V_{TS} falling	29.7	30	30.5	%VDRV
$V_{HYS(HOT)}$	Hysteresis on high threshold	V_{TS} rising		1		
V_{COLD}	Low temperature threshold	V_{TS} rising	59.5	60	60.4	
V_{WARM}	Warm temperature threshold	V_{TS} falling	37.9	38.3	39.6	
$V_{HYS(WARM)}$	Hysteresis on warm threshold	V_{TS} rising		1		
V_{COOL}	Cool temperature threshold	V_{TS} rising	56.0	56.5	56.9	
$V_{HYS(COOL)}$	Hysteresis on cool threshold	V_{TS} falling		1		
$V_{HYS(COLD)}$	Hysteresis on low threshold	V_{TS} falling		1		
$TSOFF$	TS Disable threshold	V_{TS} rising, 2% V_{DRV} Hysteresis	70		73	
$t_{DGL(TS)}$	Deglitch time on TS change			50		ms

BLOCK DIAGRAM

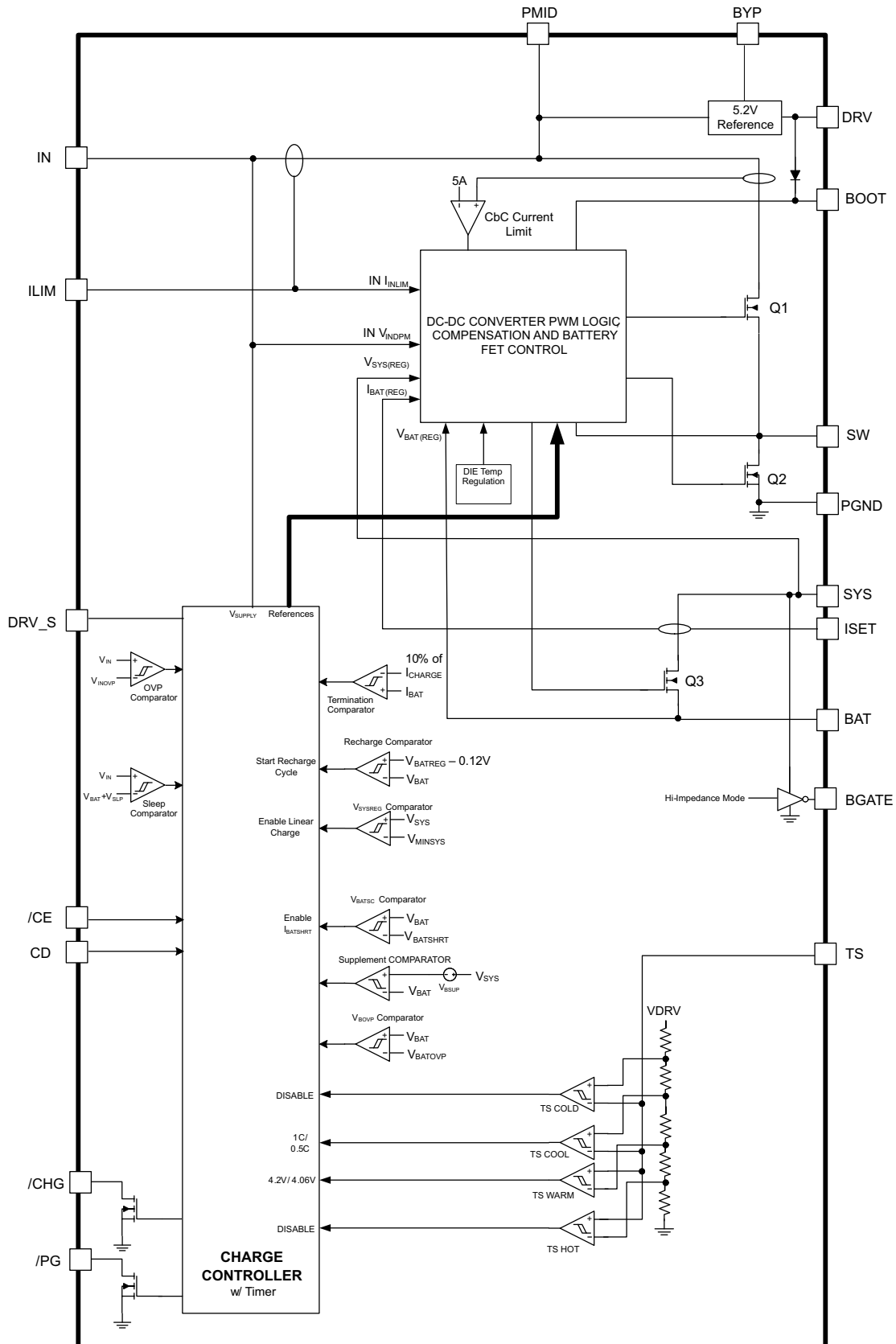

PIN CONFIGURATION

49-BALL WCSP
(TOP VIEW)

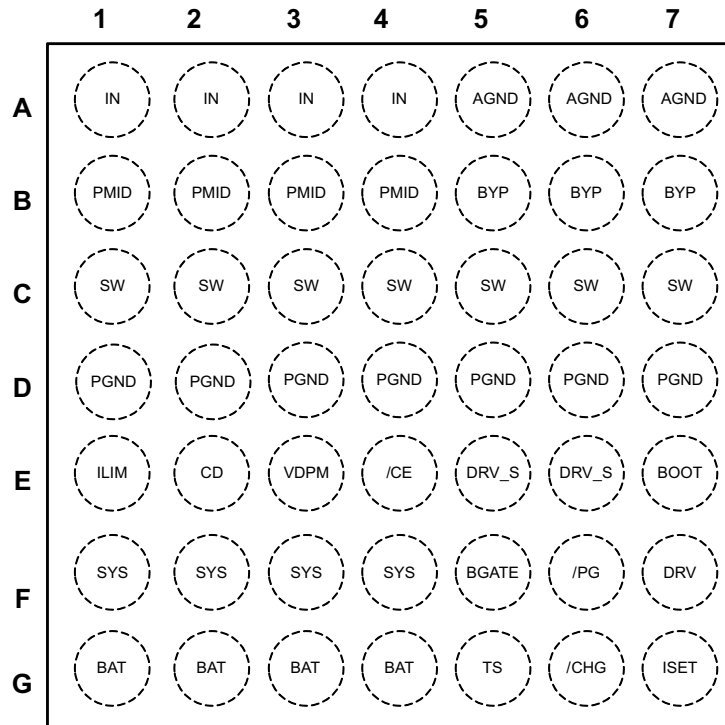

24-PIN QFN
(TOP VIEW)

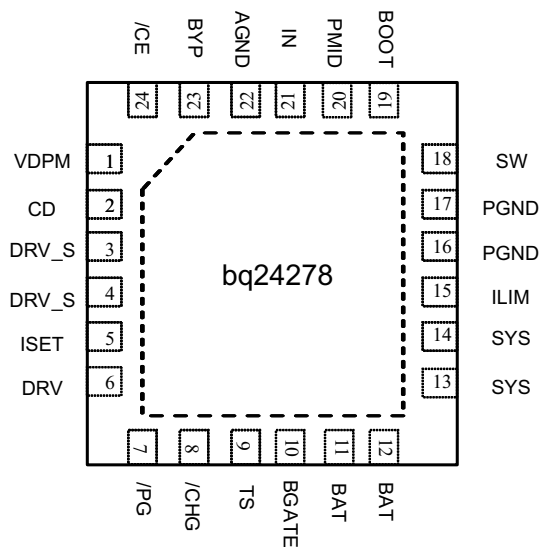

PIN FUNCTIONS

PIN		I/O	DESCRIPTION	
NAME	NUMBER			
YFF	RGE			
IN	A1-A4	21	I	Input power supply. IN is connected to the external DC supply (AC adapter or alternate power source). Bypass IN to PGND with at least a 1µF ceramic capacitor.
AGND	A5-A7	22	I	Ground terminal. Connect to the thermal pad (for QFN only) and the ground plane of the circuit.
PMID	B1-B4	20	O	Reverse Blocking MOSFET and High Side MOSFET Connection Point for High Power Input. Bypass PMID to PGND with at least a 4.7µF ceramic capacitor. Use caution when connecting an external load to PMID. The PMID output is not current limited. Any short on PMID will result in damage to the IC.
BYP	B5-B7	23	O	Bypass for internal supply. Bypass BYP to GND with at least a 0.1µF ceramic capacitor.
SW	C1-C7	18	O	Inductor Connection. Connect to the switched side of the external inductor.
PGND	D1-D7	16, 17	—	Ground terminal for Switching FET. Connect to the thermal pad (for QFN only) and the ground plane of the circuit.
ILIM	E1	15	I	IN Input Current Limit Programming Input. Connect a resistor from ILIM to GND to program the input current limit for IN. The current limit is programmable from 1A to 2.5A.
CD	E2	2	I	IC Hardware Disable Input. Drive CD high to place the bq24278 in high-z mode. Drive CD low for normal operation.
VDPM	E3	1	I	Input DPM Programming Input. Connect a resistor divider from IN to PGND with VDPM connected to the center tap to program the Input Voltage based Dynamic Power Management (VIN_DPM) threshold. The input current is reduced to maintain the supply voltage at V _{IN_DPM} . See the <i>Input Voltage based Dynamic Power Management</i> section for a detailed explanation.
$\overline{\text{CE}}$	E4	24	I	Charge Enable Input. $\overline{\text{CE}}$ is used to disable or enable the charge process. A low logic level (0) enables charging and a high logic level (1) disables charging. When charging is disabled, the SYS output remains in regulation, but BAT is disconnected from SYS. Supplement mode is still available if the system load demands cannot be met by the supply.
DRV_S	E5, E6	3, 4	I	Supply for Internal Circuits. Connect DRV_S to DRV directly.
BOOT	E7	19	I	High Side MOSFET Gate Driver Supply. Connect a 0.01µF ceramic capacitor (voltage rating > 10V) from BOOT to SW to supply the gate drive for the high side MOSFETs.
SYS	F1-F4	13,14	I/O	System Voltage Sense and Charger FET Connection. Connect SYS to the system output at the output bulk capacitors. Bypass SYS locally with 1µF.
BGATE	F5	10	O	External Discharge MOSFET Gate Connection. BGATE drives an external P-Channel MOSFET to provide a very low resistance discharge path. Connect BGATE to the gate of the external MOSFET. BGATE is low during supplement mode and when no input is connected.
$\overline{\text{PG}}$	F6	7	I	Power Good Open Drain Output. $\overline{\text{PG}}$ is pulled low when a valid supply is connected to IN. A valid supply is between V _{BAT} +V _{SLP} and V _{OVP} . If no supply is connected or the supply is out of this range, $\overline{\text{PG}}$ is high impedance.
DRV	F7	6	O	Gate Drive Supply. DRV is the bias supply for the gate drive of the internal MOSFETs. bypass DRV to PGND with a 1µF ceramic capacitor. DRV may be used to drive external loads up to 10mA. DRV is active whenever the input is connected and V _{SUPPLY} > V _{UVLO} and V _{SUPPLY} > (V _{BAT} + V _{SLP})
BAT	G1-G4	11, 12	I/O	Battery Connection. Connect to the positive terminal of the battery. Additionally, bypass BAT to GND with a 1µF capacitor.
TS	G5	9	I	Battery Pack NTC Monitor. Connect TS to the center tap of a resistor divider from DRV to GND. The NTC is connected from TS to GND. The TS function in the bq24278 provides 2 thresholds for Hot/ Cold shutoff, with 2 additional thresholds for JEITA compliance. See the <i>NTC Monitor</i> section for more details on operation and selecting the resistor values.
$\overline{\text{CHG}}$	G6	8	O	Charge Status Open Drain Output. $\overline{\text{CHG}}$ is pulled low when a charge cycle starts and remains low while charging. $\overline{\text{CHG}}$ is high impedance when the charging terminates and when no supply exists. $\overline{\text{CHG}}$ does not indicate recharge cycles.
ISET	G7	5	I	Charge Current Programming Input. Connect a resistor from ISET to GND to program the fast charge current. The charge current is programmable from 550mA to 2.5A.
Thermal Pad	—	Pad	—	There is an internal electrical connection between the exposed thermal pad and the VSS pin of the device. The thermal pad must be connected to the same potential as the VSS pin on the printed circuit board. Do not use the thermal pad as the primary ground input for the device. VSS pin must be connected to ground at all times.

TYPICAL APPLICATION CIRCUIT

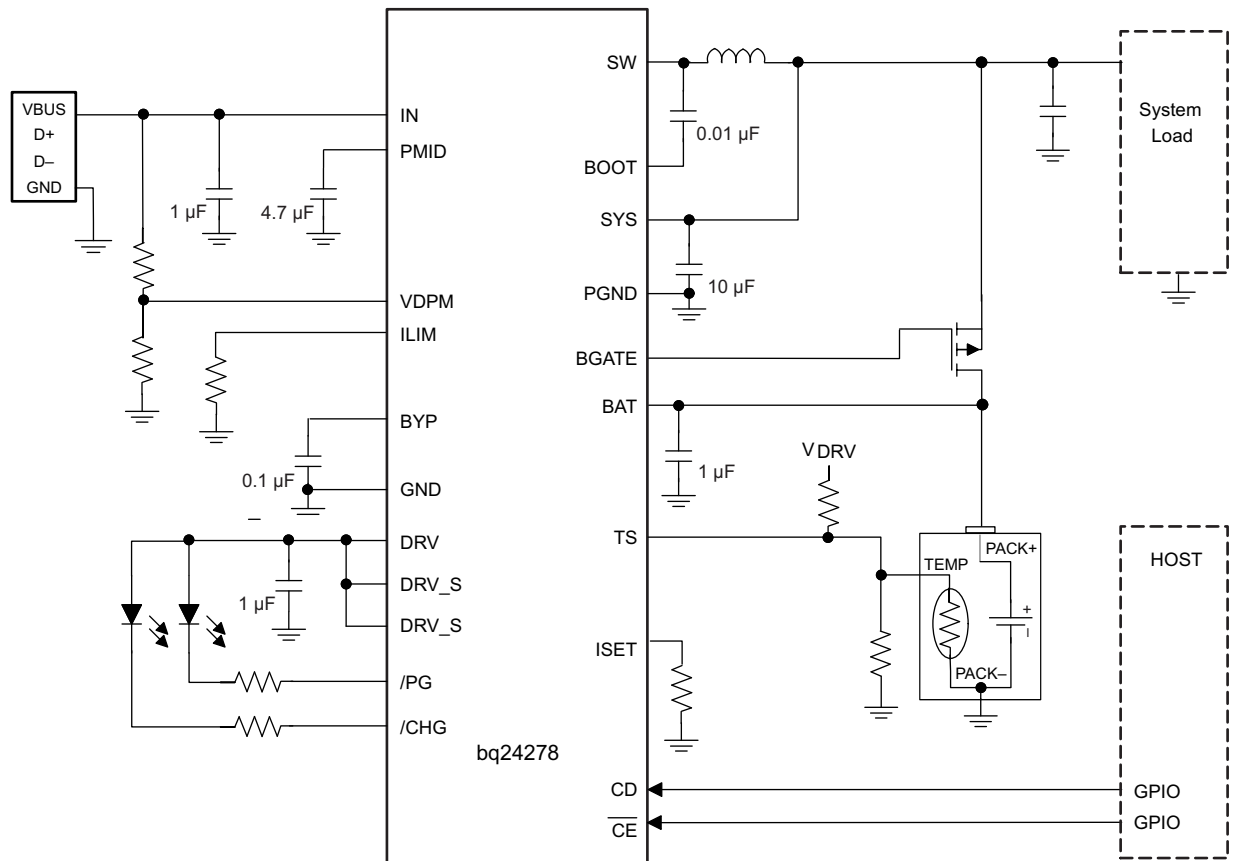

Figure 1. bq24278 Application Circuit, External Discharge FET Connected

DETAILED DESCRIPTION

The bq24278 is a highly integrated single cell Li-Ion battery charger and system power path management devices targeted for space-limited, portable applications with high capacity batteries. The power path management feature allows the bq24278 to power the system from a high efficiency DC to DC converter while simultaneously and independently charging the battery. The charger monitors the battery current at all times and reduces the charge current when the system load requires current above the input current limit. This allows for proper charge termination and enables the system to run with a defective or absent battery pack. Additionally, this enables instant system turn-on even with a totally discharged battery or no battery. The power-path management architecture also permits the battery to supplement the system current requirements when the adapter cannot deliver the peak system currents. This enables the use of a smaller adapter. The battery is charged in three phases: conditioning, constant current and constant voltage. In all charge phases, an internal control loop monitors the IC junction temperature and reduces the charge current if the internal temperature threshold is exceeded.

Charge Mode Operation

Charge Profile

Charging is done through the internal battery MOSFET. When the battery voltage is above 3.5V, the system output (SYS) is connected to the battery to maximize the charging efficiency. There are 5 loops that influence the charge current; constant current loop (CC), constant voltage loop (CV), thermal regulation loop, minimum system voltage loop (MINSYS) and input voltage dynamic power management loop (V_{IN-DPM}). During the charging process, all five loops are enabled and the dominant one takes control. The bq24278 supports a precision Li-Ion or Li-Polymer charging system for single-cell applications. The minimum system output feature regulates the system voltage to a minimum of $V_{SYS(REG)}$, so that startup is enabled even for a missing or deeply discharged battery. Figure 2 shows a typical charge profile including the minimum system output voltage feature.

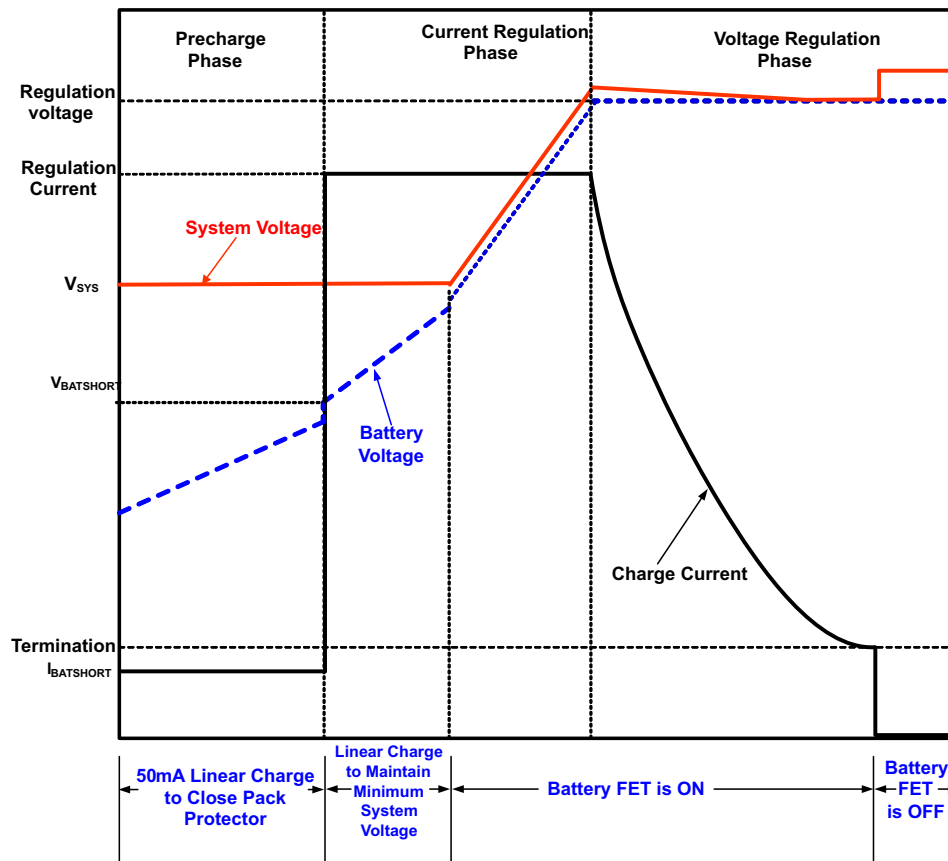

Figure 2. Typical Charging Profile of bq24278

PWM Controller in Charge Mode

The bq24278 provides an integrated, fixed 1.5 MHz frequency voltage-mode controller with to power the system and supply the charge current. The converter is internally compensated and provides enough phase margin for stable operation, allowing the use of small ceramic capacitors with very low ESR.

The bq24278 input scheme prevents battery discharge when the supply voltage is lower than V_{BAT} . The high-side N-MOSFET (Q1) switches to control the power delivered to SYS. The DRV LDO supplies the gate drive for the internal MOSFETs. The high-side MOSFET is supplied by a boot strap circuit with external boot-strap capacitor (BST).

The input is protected from short circuit by a cycle-by-cycle current limit that is sensed through the high-side MOSFET. The threshold is set to a nominal 5-A peak current. The input also utilizes an input current limit that limits the current from the power source.

Battery Charging Process

When the battery is deeply discharged or shorted, the bq24278 applies a 50mA current to charge the battery voltage up to acceptable charging levels. During this time, the battery FET is linearly regulated to maintain the system output regulation at $V_{SYS(REG)}$. Once the battery rises above V_{SHORT} , the charge current increases to the fastcharge current setting. The SYS voltage is regulated to $V_{SYS(REG)}$ while the battery is linearly charged through the battery FET. Additionally, the thermal regulation loop reduces the charge current to maintain the die temperature at safe levels. Under normal conditions, the time spent in this region is a very short percentage of the total charging time, so if the charge current is reduced, the reduced charge rate does not have a major negative effect on total charge time. If the current limit for the SYS output is reached (limited by the input current limit, or V_{IN_DPM}), the charge current is reduced to provide the system with all the current that is needed. If the charge current is reduced to 0mA, pulling further current from SYS causes the output to fall to the battery voltage and enter supplement mode (see the “*Dynamic Power Path Management*” section for more details).

Once the battery is charged enough to where the system voltage begins to rise above V_{SYSREG} (depends on the charge current setting), the battery FET is turned on fully and the battery is charged with the programmed charge current programmed using the ISET input, I_{CHARGE} . The slew rate for fast charge current is controlled to minimize the current and voltage over-shoot during transient. The charge current is programmed by connecting a resistor from ISET to GND. The value for R_{ISET} is calculated using [Equation 1](#).

$$R_{ISET} = \frac{K_{ISET}}{I_{CHARGE}} \quad (1)$$

Where I_{CHARGE} is the programmed fast charge current and K_{ISET} is the programming factor found in the Electrical Characteristics table.

The charge current is regulated to I_{CHARGE} until the battery is charged to the regulation voltage. Once the battery voltage is close to the regulation voltage, $V_{BAT(REG)}$, the charge current is tapered down as shown in [Figure 2](#) while the SYS output remains connected to the battery. The voltage regulation feedback occurs by monitoring the battery-pack voltage between the BAT and PGND pins.

The bq24278 monitors the charging current during the voltage regulation phase. Once the termination threshold, I_{TERM} , is detected and the battery voltage is above the recharge threshold, the bq24278 terminates charge and turns off the battery charging FET and begins battery detection. The system output is regulated to the $V_{BAT(REG)}$ voltage and supports the full current available from the input and the battery supplement mode (see the “*Dynamic Power Path Management*” section for more details) is still available.

A charge cycle is initiated when one of the following conditions is detected:

1. The battery voltage falls below the $V_{BAT(REG)} - V_{RCH}$ threshold.
2. V_{IN} Power-on reset (POR)
3. \overline{CE} toggle
4. Toggle Hi-Impedance mode (using CD)

If the battery voltage is ever greater than $V_{BAT(REG)}$, the PWM converter is turned off and the battery is discharged to $V_{BAT(REG)}$. This prevents further overcharging the battery and allows the battery to discharge to safe operating levels.

Battery Detection

When termination conditions are met, a battery detection cycle is started. During battery detection, I_{DETECT} is pulled from V_{BAT} for t_{DETECT} to verify there is a battery. If the battery voltage remains above V_{DETECT} for the full duration of t_{DETECT} , a battery is determined to be present and the IC enters “Charge Done”. If V_{BAT} falls below V_{DETECT} , a “Battery Not Present” fault is signaled and battery detection continues. During the next cycle of battery detection, the bq24278 turns on I_{BATSHORT} for t_{DETECT} . If V_{BAT} rises to V_{DETECT} , the current source is turned off and after t_{DETECT} , the battery detection continues through another current sink cycle. Battery detection continues until charge is disabled or a battery is detected. Once a battery is detected, the fault status clears and a new charge cycle begins. Battery detection is disabled when termination is disabled.

Dynamic Power Path Management

The bq24278 features a SYS output that powers the external system load connected to the battery. This output is active whenever a source is connected to IN or BAT. The following sections discuss the behavior of SYS with a source connected to the supply or a battery source only.

Input Source Connected

When a source is connected to IN, and the bq24278 is enabled, the buck converter starts up. If charging is enabled using $\overline{\text{CE}}$, the charge cycle is initiated. When $V_{\text{BAT}} > 3.5\text{V}$, the SYS output is connected to V_{BAT} . If the SYS voltage falls to $V_{\text{SYS(REG)}}$, it is regulated to that point to maintain the system output even with a deeply discharged or absent battery. In this mode, the SYS output voltage is regulated by the buck converter and the battery FET is linearly regulated to regulate the charge current into the battery. The current from the supply is shared between charging the battery and powering the system load at SYS. The dynamic power path management (DPPM) circuitry of the bq24278 monitors the SYS voltage continuously and if V_{SYS} falls to V_{MINSYS} , adjusts charge current to maintain the load on SYS while preventing the system voltage from crashing. If the charge current is reduced to zero and the load increases further, the bq24278 enters battery supplement mode. During supplement mode, the battery FET is turned on and the battery supplements the system load. When the charge current is reduced by the DPPM regulation loop, the safety timer runs at half speed, so that it is twice as long. This prevents false safety timer faults. See the *Safety Timer* section for more details.

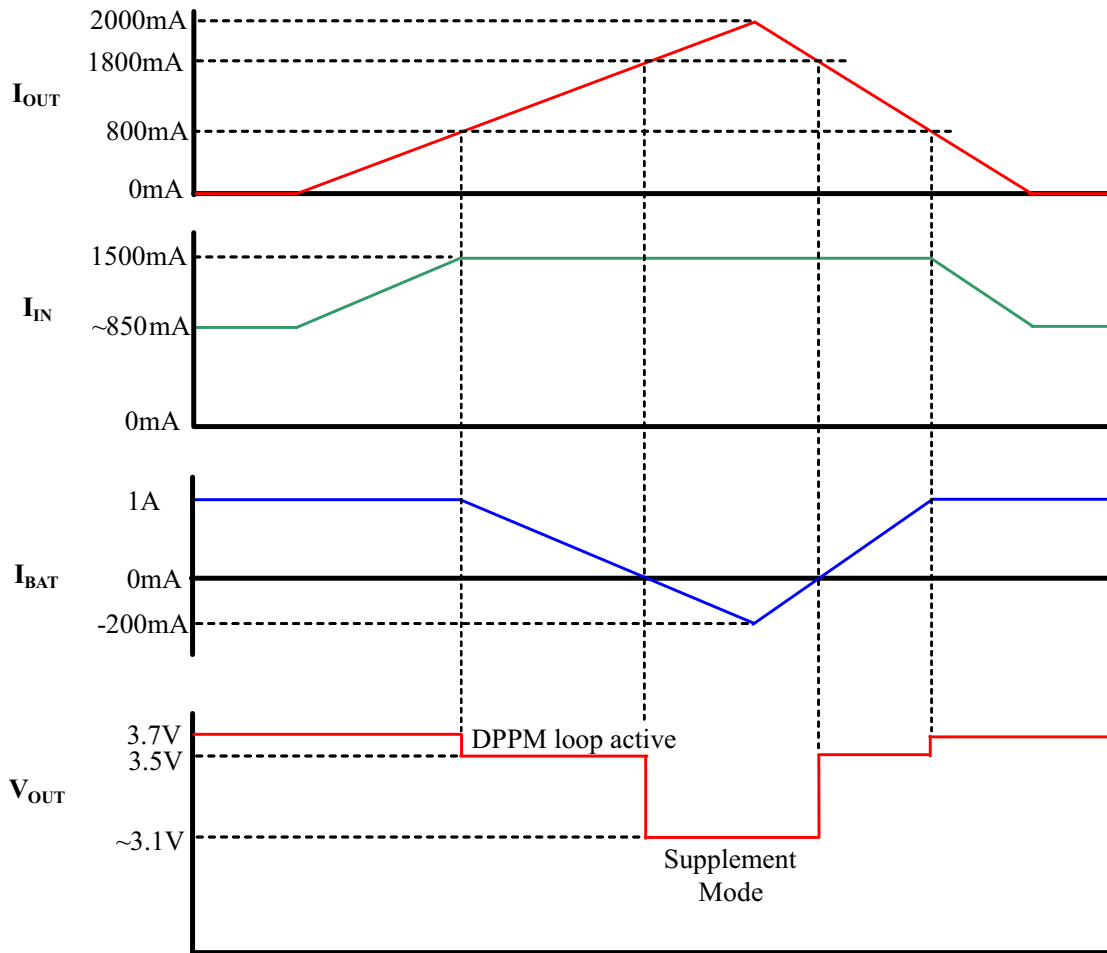

Figure 3. Example DPPM Response ($V_{Supply}=5V$, $V_{BAT} = 3.1V$, 1.5A Input current limit)

If the $V_{BAT(REG)}$ threshold is ever less than the battery voltage, the battery FET is turned off to allow the battery to relax down to $V_{BAT(REG)}$ and the SYS output is regulated to $V_{SYSREG(FETOFF)}$. If the battery is ever above V_{BOVP} , the battery OVP circuit shuts the PWM converter off and the battery FET is turned on to discharge the battery to safe operating levels.

The input current limit for IN is programmable using the ILIM input. Connect a resistor from ILIM to GND to set the maximum input current limit. The programmable range for the IN input current limit is 1000mA to 2.5A. R_{ILIM} is calculated using Equation 2:

$$R_{ILIM} = \frac{K_{ILIM}}{I_{IN_LIM}} \quad (2)$$

Where I_{IN_LIM} is the programmed input current limit and K_{ILIM} is the programming factor found in the Electrical Characteristics table.

Battery Only Connected

When the battery is connected with no input source, the battery FET is turned on similar to supplement mode. In this mode, the current is not regulated; however, there is a short circuit current limit. If the short circuit limit is reached, the battery FET is turned off for the deglitch time. After the deglitch time, the battery FET is turned on to test and see if the short has been removed. If it has not, the FET turns off and the process repeats until the short is removed.

Battery Discharge FET (BGATE)

The bq24278 contains a MOSFET driver to drive an external P-Channel MOSFET between the battery and the system output. This external FET provides a low impedance path for supply the system from the battery. Connect BGATE to the gate of the external discharge MOSFET. BGATE is on under the following conditions:

1. No valid input supply connected.
2. CD=high (High-Impedance Mode)

This FET is optional and runs in parallel with the internal charge FET during discharge. Note that this FET is not protected by the short circuit current limit.

Safety Timer

At the beginning of charging process, the bq24278 starts the 6 hour safety timer. This timer is active during the entire charging process. If charging has not terminated before the safety timer expires, the charge cycle is terminated and the battery FET is turned off. A new charge cycle must be entered using $\overline{\text{CE}}$ or High Impedance mode or input power must be toggled in order to clear the safety timer fault.

During the fast charge phase, several events increase the timer durations.

1. The system load current reduces the available charging current
2. The input current is reduced because the V_{INDPM} loop is preventing the supply from crashing.
3. The device has entered thermal regulation because the IC junction temperature has exceed $T_{\text{J(REG)}}$

During these events, the timer is slowed by half to extend the timer and prevent any false timer faults. Starting a new charge cycle by toggling the input, toggling the $\overline{\text{CE}}$ pin to disable/enable charge, resets the safety timer. Additionally, thermal shutdown events cause the safety timer to reset.

LDO Output (DRV)

The bq24278 contains a linear regulator (DRV) that is used to supply the internal MOSFET drivers and other circuitry. Additionally, DRV supplies up to 10mA external loads to power the STAT LED or other external circuitry. The LDO is on whenever a supply is connected to the input of the. The DRV is disabled under the following conditions:

1. $V_{\text{IN}} < \text{UVLO}$
2. $V_{\text{IN}} < V_{\text{BAT}} + V_{\text{SLP}}$
3. Thermal Shutdown

External NTC Monitoring (TS)

The I²C interface allows the user to easily implement the JEITA standard for systems where the battery pack thermistor is monitored by the host. Additionally, the bq24278 provides a flexible, voltage-based TS input for monitoring the battery pack NTC thermistor, [Figure 4](#). The voltage at TS is monitored to determine that the battery is at a safe temperature during charging. The bq24278 enables the user to easily implement the JEITA standard for charging temperature. The JEITA specification is shown in [Figure 5](#).

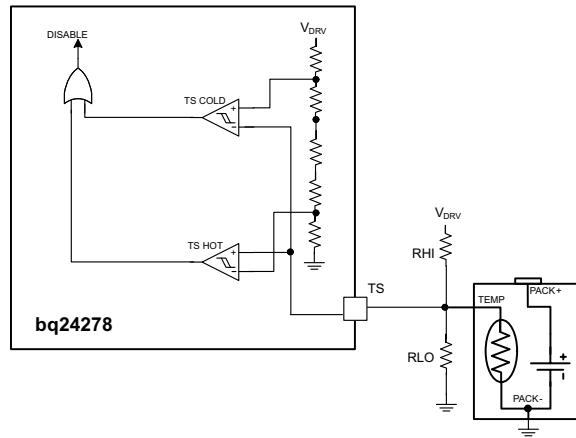

Figure 4. TS Circuit

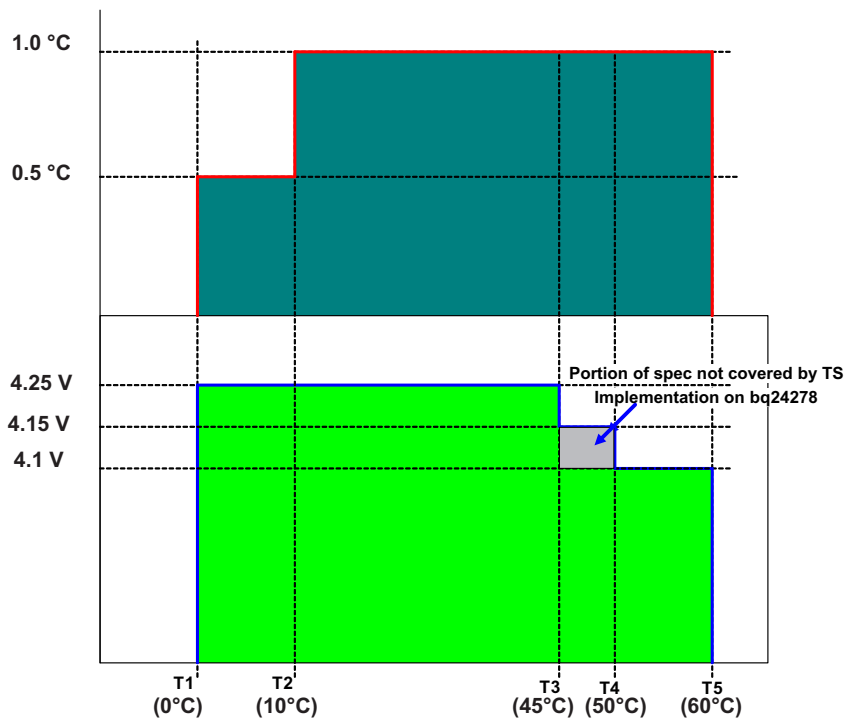

Figure 5. Charge Current During TS Conditions

To satisfy the JEITA requirements, four temperature thresholds are monitored; the cold battery threshold; the cold battery threshold ($T_{NTC} < 0^{\circ}\text{C}$), the cool battery threshold ($0^{\circ}\text{C} < T_{NTC} < 10^{\circ}\text{C}$), the warm battery threshold ($45^{\circ}\text{C} < T_{NTC} < 60^{\circ}\text{C}$) and the hot battery threshold ($T_{NTC} > 60^{\circ}\text{C}$). These temperatures correspond to the V_{COLD} , V_{COOL} , V_{WARM} , and V_{HOT} thresholds. Charging is suspended and timers are suspended when $V_{TS} < V_{HOT}$ or $V_{TS} > V_{COLD}$. When $V_{HOT} < V_{TS} < V_{WARM}$, the battery regulation voltage is reduced by 140 mV from the programmed regulation threshold. When $V_{COOL} < V_{TS} < V_{COLD}$, the charging current is reduced to half of the programmed charge current.

The TS function is voltage based for maximum flexibility. Connect a resistor divider from DRV to GND with TS connected to the center tap to set the threshold. The connections are shown in Figure 10. The resistor values are calculated using the following equations:

$$RLO = \frac{V_{DRV} \times RCOLD \times RHOT \times \left[\frac{1}{V_{COLD}} - \frac{1}{V_{HOT}} \right]}{RHOT \times \left[\frac{V_{DRV}}{V_{HOT}} - 1 \right] - RCOLD \times \left[\frac{V_{DRV}}{V_{COLD}} - 1 \right]} \quad (3)$$

$$RHI = \frac{\frac{V_{DRV}}{V_{COLD}} - 1}{\frac{1}{RLO} + \frac{1}{RCOLD}} \quad (4)$$

Where:

$$V_{COLD} = 0.60 \times V_{DRV}$$

$$V_{HOT} = 0.30 \times V_{DRV}$$

Where RHOT is the NTC resistance at the hot temperature and RCOLD is the NTC resistance at cold temperature.

The WARM and COOL thresholds are not independently programmable. The COOL and WARM NTC resistances for a selected resistor divider are calculated using the following equations:

$$RCOOL = \frac{RLO \times 0.564 \times RHI}{RLO - RLO \times 0.564 - RHI \times 0.564} \quad (5)$$

$$RWARM = \frac{RLO \times 0.383 \times RHI}{RLO - RLO \times 0.383 - RHI \times 0.383} \quad (6)$$

Thermal Regulation and Protection

During the charging process, to prevent the IC from overheating, bq24278 monitor the junction temperature, T_J , of the die and begins to taper down the charge current once T_J reaches the thermal regulation threshold, T_{CF} . The charge current is reduced to zero when the junction temperature increases about 10°C above T_{CF} . Once the charge current is reduced, the system current is reduced while the battery supplements the load to supply the system. This may cause a thermal shutdown of the bq24278 if the die temperature rises too high. At any state, if T_J exceeds T_{SHTDWN} , bq24278 suspends charging and disables the buck converter. During thermal shutdown mode, PWM is turned off, and the timer is reset. The charging cycle resets when T_J falls below T_{SHTDWN} by approximately 10°C.

Input Voltage Protection in Charge Mode

Sleep Mode

The bq24278 enters the low-power sleep mode if the voltage on V_{IN} falls below sleep-mode entry threshold, $V_{BAT} + V_{SLP}$, and V_{VBUS} is higher than the undervoltage lockout threshold, V_{UVLO} . This feature prevents draining the battery during the absence of V_{IN} . When $V_{IN} < V_{BAT} + V_{SLP}$, the bq24278 turns off the PWM converter, and turns the battery FET and BGATE on. Once $V_{IN} > V_{BAT} + V_{SLP}$, the device initiates a new charge cycle.

Input Voltage Based DPM

During normal charging process, if the input power source is not able to support the programmed or default charging current, the supply voltage decreases. Once the supply drops to V_{IN_DPM} (set by VDPM), the input current limit is reduced down to prevent the further drop of the supply. This feature ensures IC compatibility with adapters with different current capabilities without a hardware change. [Figure 6](#) shows the V_{IN_DPM} behavior to a current limited source. In this figure the input source has a 750mA current limit and the charging is set to 750mA. The SYS load is then increased to 1.2A.

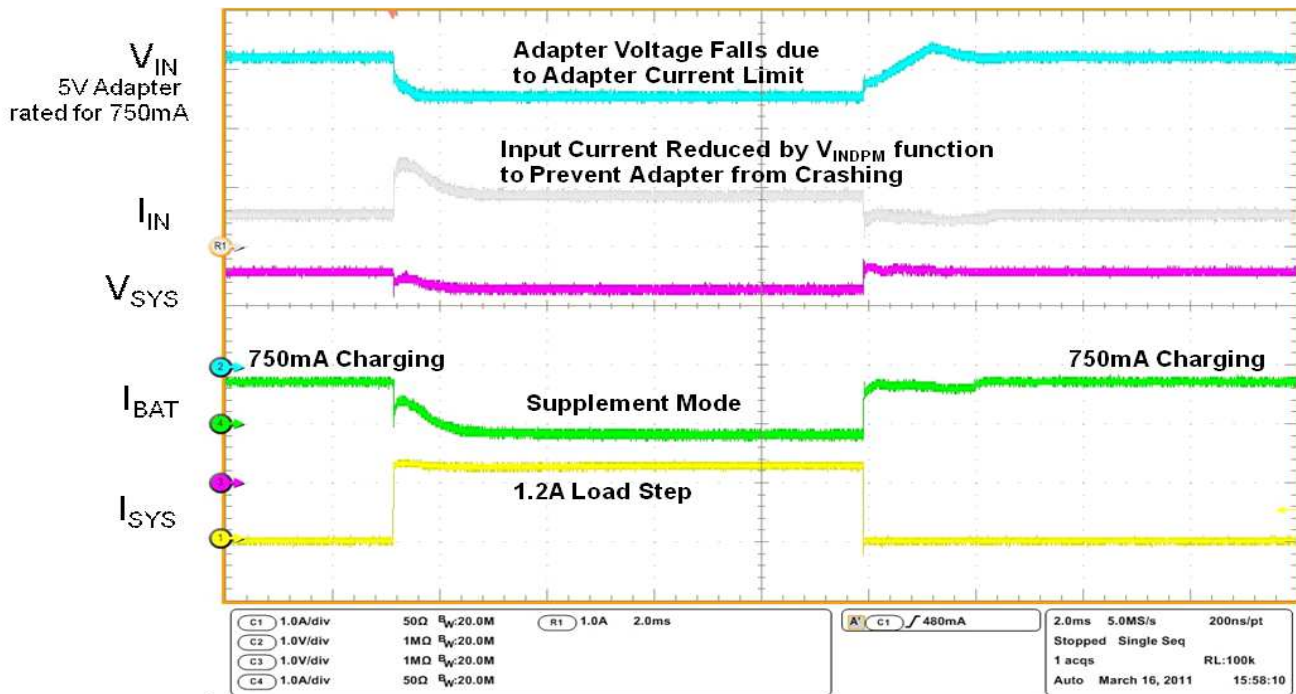

Figure 6. bq24278 V_{IN}-DPM

The V_{INDPM} threshold for the IN input is set using a resistor divider with VDPM connected to the center tap. Select 10kΩ for the bottom resistor. The top resistor is selected using Equation 7:

$$R_{TOP} = \frac{10k\Omega \times (V_{INDPM} - V_{DPM})}{V_{DPM}} \quad (7)$$

Where V_{INDPM} is the desired V_{INDPM} threshold and V_{DPM} is the regulation threshold specified in the Electrical Characteristics table.

Bad Source Detection

When a source is connected to IN, the bq24278 runs a Bad Source Detection procedure to determine if the source is strong enough to provide some current to charge the battery. A current sink is turned on (70mA) for 32ms. If the source is valid after the 32ms ($V_{BAD_SOURCE} < V_{IN} < V_{OVP}$), the buck converter starts up and normal operation continues. If the supply voltage falls below V_{BAD_SOURCE} during the detection, the current sink shuts off for 2s and then retries. The detection circuit retries continuously until a valid source is detected after the detection time. If during normal operation the source falls to V_{BAD_SOURCE}, the bq24278 turns off the PWM converter, turns the battery FET on and runs the bad source detection. Once a good source is detected, the device returns to normal operation.

Input Over-Voltage Protection

The bq24278 provides over-voltage protection on the input that protects downstream circuitry. The built-in input over-voltage protection to protect the device and other components against damage from overvoltage on the input supply (Voltage from V_{IN} to PGND). When V_{IN} > V_{OVP}, the bq24278 turns off the PWM converter, suspends the charging cycle and turns the battery FET on. Once the OVP fault is removed, the device returns to the operation it was in prior to the OVP fault.

Status Indicators (\overline{CHG} , \overline{PG})

The bq24278 contains two open-drain outputs that signal its status. The \overline{PG} output indicates that a valid input source is connected to IN. \overline{PG} is low when $(V_{BAT} + V_{SLP}) < V_{IN} < V_{OVP}$. When there is no supply connected to the input within this range, \overline{PG} is high impedance. Table 1 illustrates the \overline{PG} behavior under different conditions.

The $\overline{\text{CHG}}$ output indicates new charge cycles. When a new charge cycle is initiated by $\overline{\text{CE}}$, toggling High Impedance mode or toggling the input power, $\overline{\text{CHG}}$ goes low and remains low until termination. After termination, $\overline{\text{CHG}}$ remains high impedance until a new charge cycle is initiated. $\overline{\text{CHG}}$ does not go low during recharge cycles. [Table 2](#) illustrates the $\overline{\text{CHG}}$ behavior under different conditions.

Connect $\overline{\text{PG}}$ and $\overline{\text{CHG}}$ to the DRV output through an LED for visual indication, or connect through a 100k Ω pullup to the required logic rail for host indication.

Table 1. $\overline{\text{PG}}$ Status Indicator

CHARGE STATE	$\overline{\text{PG}}$ BEHAVIOR
$V_{\text{IN}} < V_{\text{UVLO}}$	High-Impedance
$V_{\text{IN}} < (V_{\text{BAT}} + V_{\text{SLP}})$	High-Impedance
$(V_{\text{BAT}} + V_{\text{SLP}}) < V_{\text{IN}} < V_{\text{OVP}}$	Low
$V_{\text{IN}} > V_{\text{OVP}}$	High-Impedance

Table 2. $\overline{\text{CHG}}$ Status Indicator

CHARGE STATE	$\overline{\text{CHG}}$ BEHAVIOR
Charge in progress	Low (first charge cycle)
Charging suspended by thermal loop	High-Impedance (recharge cycles)
Charge Done	High-Impedance
Recharge Cycle after Termination	
Timer Fault	
No Valid Supply, $V_{\text{IN}} > V_{\text{OVP}}$ or $V_{\text{IN}} < V_{\text{SLEEP}}$	
No Battery Present	

APPLICATION INFORMATION

Output Inductor and Capacitor Selection Guidelines

When selecting an inductor, several attributes must be examined to find the right part for the application. First, the inductance value should be selected. The bq24278 is designed to work with 1.5µH to 2.2µH inductors. The chosen value will have an effect on efficiency and package size. Due to the smaller current ripple, some efficiency gain is reached using the 2.2µH inductor, however, due to the physical size of the inductor, this may not be a viable option. The 1.5µH inductor provides a good tradeoff between size and efficiency.

Once the inductance has been selected, the peak current must be calculated in order to choose the current rating of the inductor. Use [Equation 8](#) to calculate the peak current.

$$I_{PEAK} = I_{LOAD(MAX)} \times \left(1 + \frac{\%RIPPLE}{2} \right) \quad (8)$$

The inductor selected must have a saturation current rating less than or equal to the calculated I_{PEAK} . Due to the high currents possible with the bq24278, a thermal analysis must also be done for the inductor. Many inductors have 40°C temperature rise rating. This is the DC current that will cause a 40°C temperature rise above the ambient temperature in the inductor. For this analysis, the typical load current may be used adjusted for the duty cycle of the load transients. For example, if the application requires a 1.5A DC load with peaks at 2.5A 20% of the time, a Δ40°C temperature rise current must be greater than 1.7A:

$$I_{TEMPRISE} = I_{LOAD} + D \times (I_{PEAK} - I_{LOAD}) = 1.5 \text{ A} + 0.2 \times (2.5 \text{ A} - 1.5 \text{ A}) = 1.7 \text{ A} \quad (9)$$

The bq24278 provides internal loop compensation. Using this scheme, the bq24278 is stable with 10µF to 200µF of local capacitance. The capacitance on the SYS rail can be higher if distributed amongst the rail. To reduce the output voltage ripple, a ceramic capacitor with the capacitance between 10µF and 47µF is recommended for local bypass to SYS.

PCB Layout Guidelines

It is important to pay special attention to the PCB layout. Figure 7 provides a sample layout for the high current paths of the bq24278.

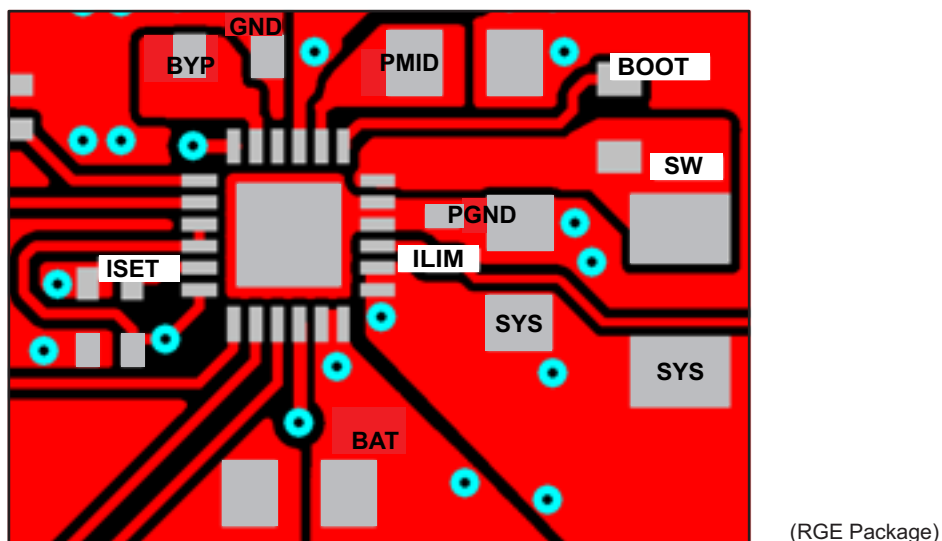

Figure 7. Recommended bq24278 PCB Layout for RGE Device

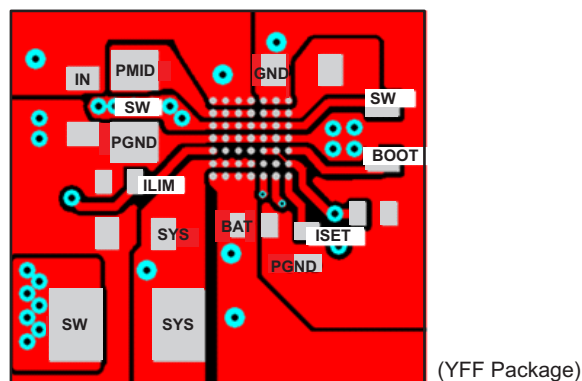

Figure 8. Recommended bq24278 PCB Layout for YFF Device

The following provides some guidelines:

- To obtain optimal performance, the power input capacitors, connected from the PMID input to PGND, must be placed as close as possible to the bq24278
- Place 4.7 μ F input capacitor as close to PMID pin and PGND pin as possible to make high frequency current loop area as small as possible. Place 1 μ F input capacitor GNDs as close to the respective PMID cap GND and PGND pins as possible to minimize the ground difference between the input and PMID.
- The local bypass capacitor from SYS to GND should be connected between the SYS pin and PGND of the IC. The intent is to minimize the current path loop area from the SW pin through the LC filter and back to the PGND pin.
- Place ISET resistor very close to the ISET pin.
- Place ILIM resistor very close to the ILIIM pin.
- Place all decoupling capacitor close to their respective IC pin and as close as to PGND (do not place components such that routing interrupts power stage currents). All small control signals should be routed away from the high current paths.
- The PCB should have a ground plane (return) connected directly to the return of all components through vias (two vias per capacitor for power-stage capacitors, one via per capacitor for small-signal components). It is

also recommended to put vias inside the PGND pads for the IC, if possible. A star ground design approach is typically used to keep circuit block currents isolated (high-power/low-power small-signal) which reduces noise-coupling and ground-bounce issues. A single ground plane for this design gives good results. With this small layout and a single ground plane, there is no ground-bounce issue, and having the components segregated minimizes coupling between signals.

- The high-current charge paths into IN, BAT, SYS and from the SW pins must be sized appropriately for the maximum charge current in order to avoid voltage drops in these traces. The PGND pins should be connected to the ground plane to return current through the internal low-side FET.
- For high-current applications, the balls for the power paths should be connected to as much copper in the board as possible. This allows better thermal performance as the board pulls heat away from the IC.

PACKAGE SUMMARY

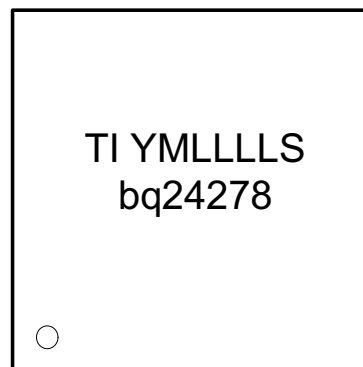
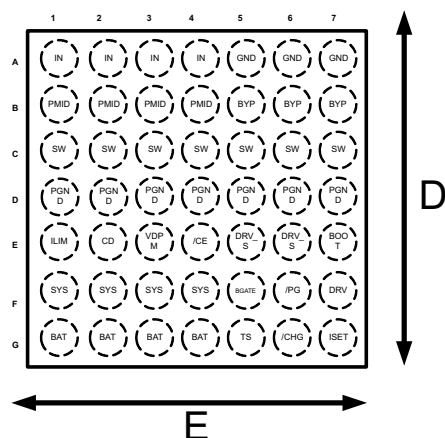

0-Pin A 1 Marker, TI-TI Letters, YM- Year Month Date Code , LLLL-Lot Trace Code , S-Assembly Site Code

CHIP SCALE PACKAGING DIMENSIONS

The bq2427x devices are available in a 49-bump chip scale package (YFF, NanoFree™). The package dimensions are :

- D – 2.78mm ± 0.05mm
- E – 2.78mm ± 0.05mm

PACKAGING INFORMATION

Orderable Device	Status (1)	Package Type	Package Drawing	Pins	Package Qty	Eco Plan (2)	Lead finish/ Ball material (6)	MSL Peak Temp (3)	Op Temp (°C)	Device Marking (4/5)	Samples
BQ24278RGER	ACTIVE	VQFN	RGE	24	3000	RoHS & Green	NIPDAU	Level-2-260C-1 YEAR	-40 to 85	BQ 24278	Samples
BQ24278RGET	ACTIVE	VQFN	RGE	24	250	RoHS & Green	NIPDAU	Level-2-260C-1 YEAR	-40 to 85	BQ 24278	Samples
BQ24278YFFR	ACTIVE	DSBGA	YFF	49	3000	RoHS & Green	SNAGCU	Level-1-260C-UNLIM	-40 to 85	BQ24278	Samples
BQ24278YFFT	ACTIVE	DSBGA	YFF	49	250	RoHS & Green	SNAGCU	Level-1-260C-UNLIM	-40 to 85	BQ24278	Samples

(1) The marketing status values are defined as follows:

ACTIVE: Product device recommended for new designs.

LIFEBUY: TI has announced that the device will be discontinued, and a lifetime-buy period is in effect.

NRND: Not recommended for new designs. Device is in production to support existing customers, but TI does not recommend using this part in a new design.

PREVIEW: Device has been announced but is not in production. Samples may or may not be available.

OBSELETE: TI has discontinued the production of the device.

(2) **RoHS:** TI defines "RoHS" to mean semiconductor products that are compliant with the current EU RoHS requirements for all 10 RoHS substances, including the requirement that RoHS substance do not exceed 0.1% by weight in homogeneous materials. Where designed to be soldered at high temperatures, "RoHS" products are suitable for use in specified lead-free processes. TI may reference these types of products as "Pb-Free".

RoHS Exempt: TI defines "RoHS Exempt" to mean products that contain lead but are compliant with EU RoHS pursuant to a specific EU RoHS exemption.

Green: TI defines "Green" to mean the content of Chlorine (Cl) and Bromine (Br) based flame retardants meet JS709B low halogen requirements of <=1000ppm threshold. Antimony trioxide based flame retardants must also meet the <=1000ppm threshold requirement.

(3) MSL, Peak Temp. - The Moisture Sensitivity Level rating according to the JEDEC industry standard classifications, and peak solder temperature.

(4) There may be additional marking, which relates to the logo, the lot trace code information, or the environmental category on the device.

(5) Multiple Device Markings will be inside parentheses. Only one Device Marking contained in parentheses and separated by a "~" will appear on a device. If a line is indented then it is a continuation of the previous line and the two combined represent the entire Device Marking for that device.

(6) Lead finish/Ball material - Orderable Devices may have multiple material finish options. Finish options are separated by a vertical ruled line. Lead finish/Ball material values may wrap to two lines if the finish value exceeds the maximum column width.

Important Information and Disclaimer:The information provided on this page represents TI's knowledge and belief as of the date that it is provided. TI bases its knowledge and belief on information provided by third parties, and makes no representation or warranty as to the accuracy of such information. Efforts are underway to better integrate information from third parties. TI has taken and

continues to take reasonable steps to provide representative and accurate information but may not have conducted destructive testing or chemical analysis on incoming materials and chemicals. TI and TI suppliers consider certain information to be proprietary, and thus CAS numbers and other limited information may not be available for release.

In no event shall TI's liability arising out of such information exceed the total purchase price of the TI part(s) at issue in this document sold by TI to Customer on an annual basis.

RGE 24

GENERIC PACKAGE VIEW

VQFN - 1 mm max height

PLASTIC QUAD FLATPACK - NO LEAD

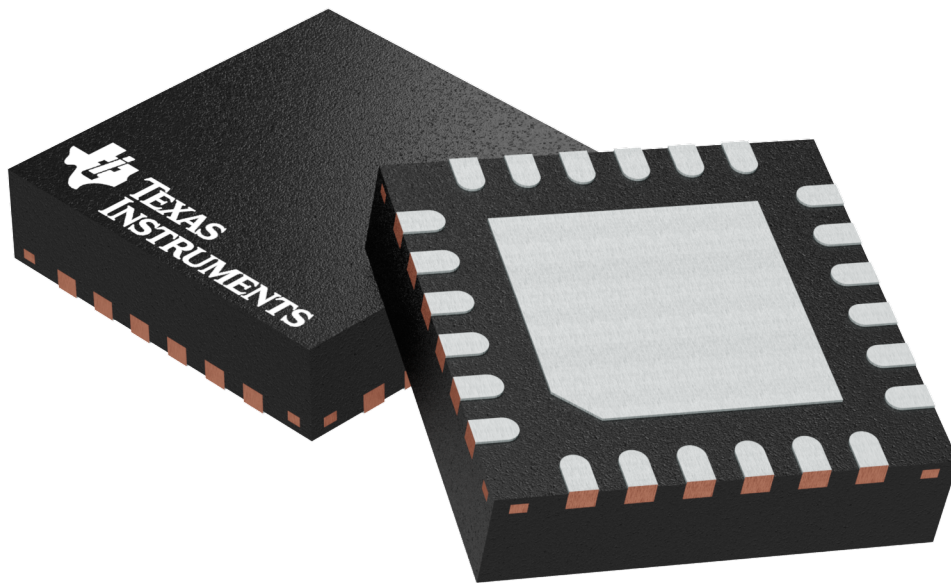

Images above are just a representation of the package family, actual package may vary.
Refer to the product data sheet for package details.

4204104/H

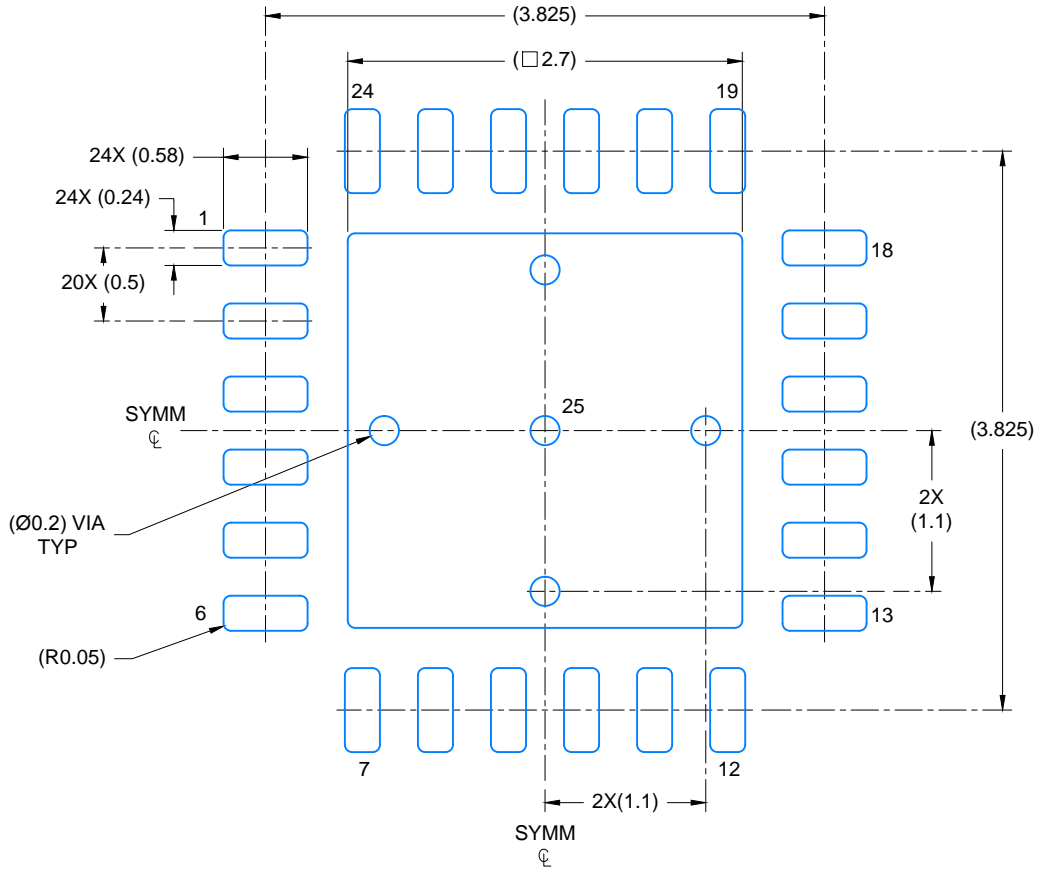

LAND PATTERN EXAMPLE
SCALE: 20X

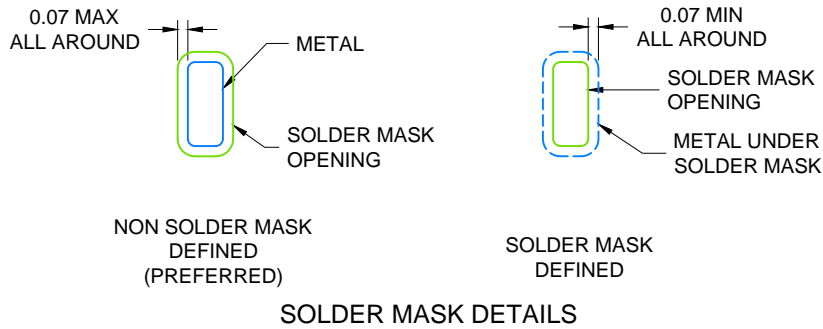

4219016 / A 08/2017

NOTES: (continued)

4. This package is designed to be soldered to a thermal pad on the board. For more information, see Texas Instruments literature number SLUA271 (www.ti.com/lit/slua271).
5. Solder mask tolerances between and around signal pads can vary based on board fabrication site.

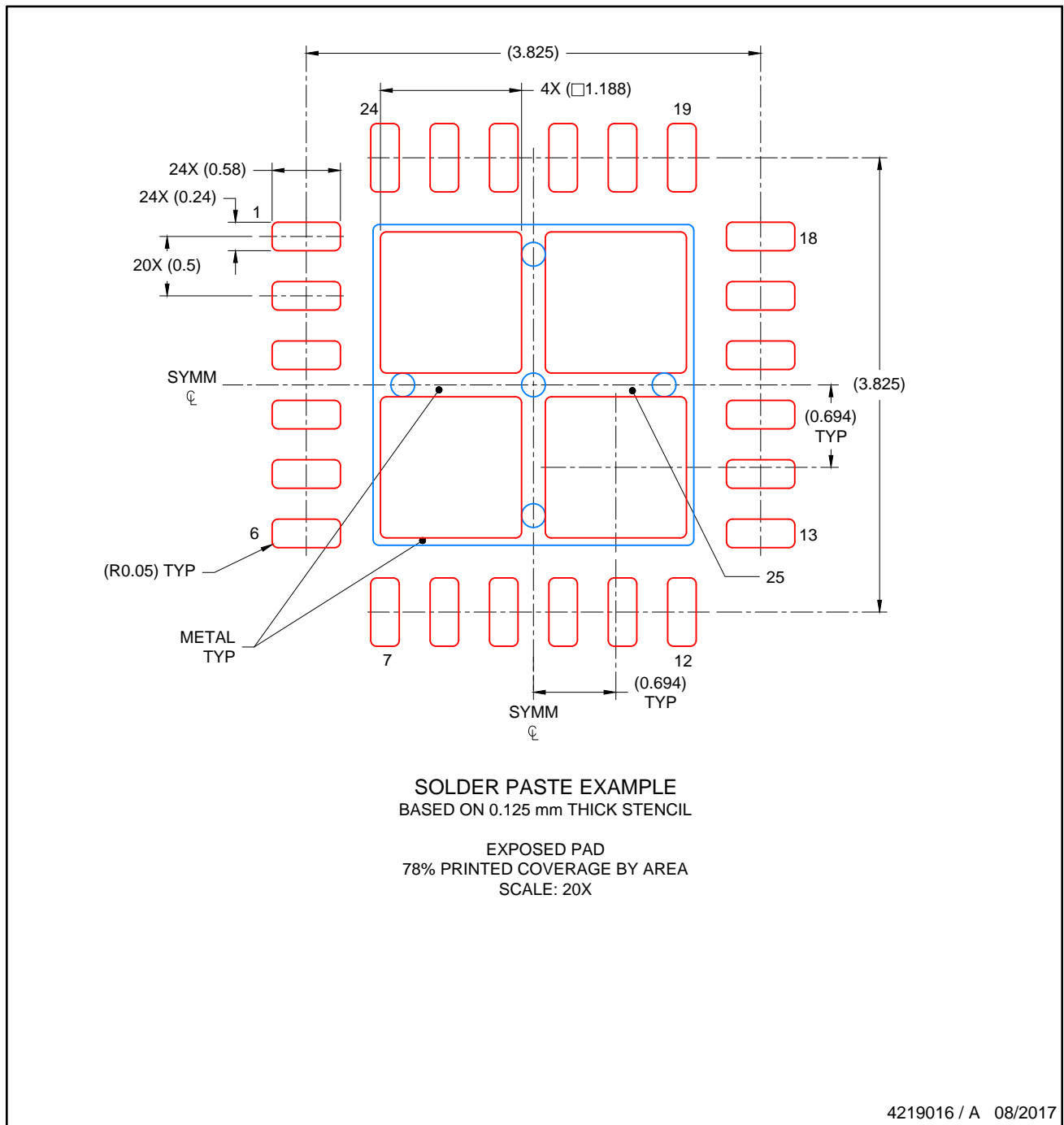

4219016 / A 08/2017

NOTES: (continued)

- 6. Laser cutting apertures with trapezoidal walls and rounded corners may offer better paste release. IPC-7525 may have alternate design recommendations..

YFF (R-XBGA-N49)

DIE-SIZE BALL GRID ARRAY

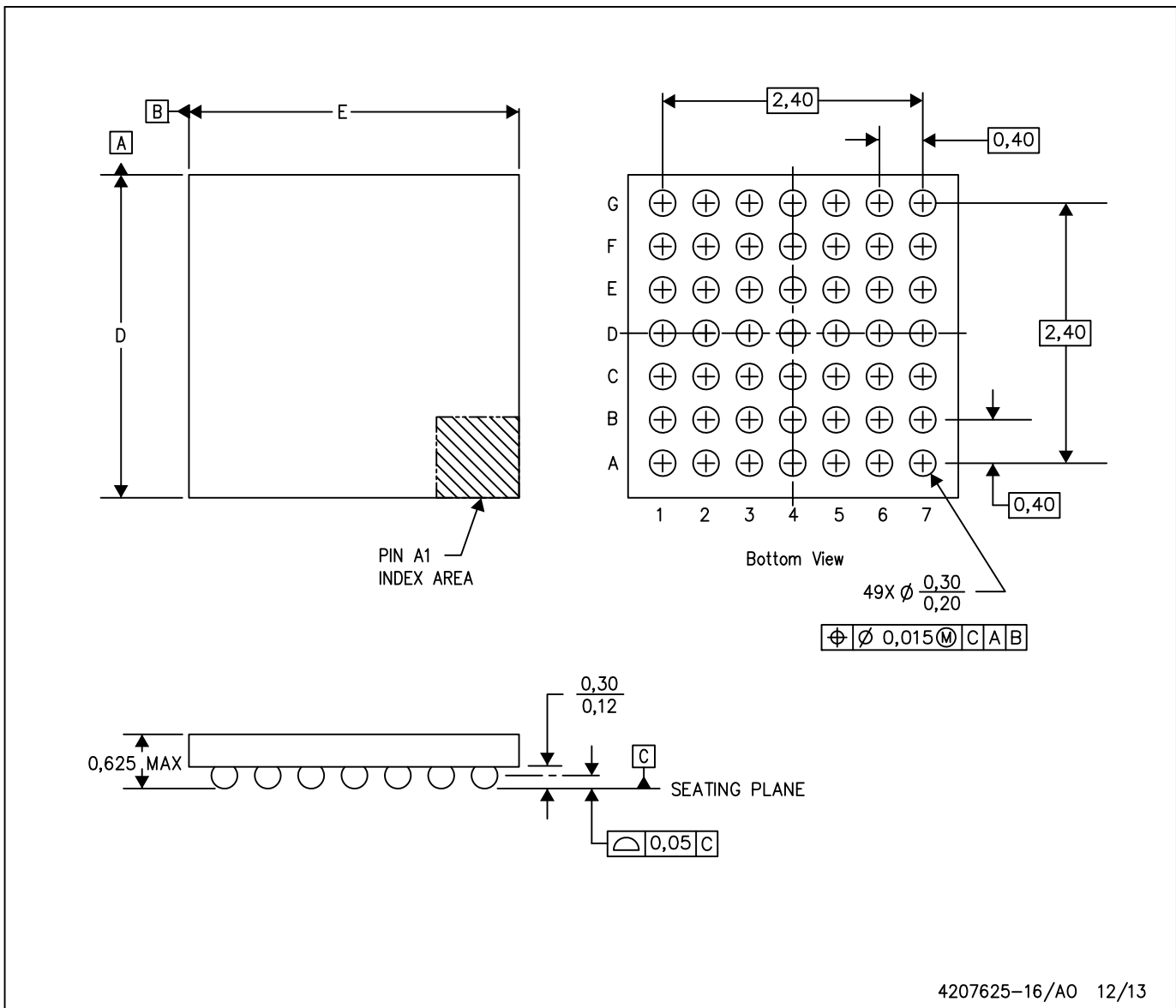

- NOTES: A. All linear dimensions are in millimeters. Dimensioning and tolerancing per ASME Y14.5M-1994.
 B. This drawing is subject to change without notice.
 C. NanoFree™ package configuration.

NanoFree is a trademark of Texas Instruments.

重要声明和免责声明

TI 均以“原样”提供技术性及其可靠性数据（包括数据表）、设计资源（包括参考设计）、应用或其他设计建议、网络工具、安全信息和其他资源，不保证其中不含任何瑕疵，且不做任何明示或暗示的担保，包括但不限于对适销性、适合某特定用途或不侵犯任何第三方知识产权的暗示担保。

所述资源可供专业开发人员应用TI 产品进行设计使用。您将对以下行为独自承担全部责任：(1) 针对您的应用选择合适的TI 产品；(2) 设计、验证并测试您的应用；(3) 确保您的应用满足相应标准以及任何其他安全、安保或其他要求。所述资源如有变更，恕不另行通知。TI 对您使用所述资源的授权仅限于开发资源所涉及TI 产品的相关应用。除此之外不得复制或展示所述资源，也不提供其它TI 或任何第三方的知识产权授权许可。如因使用所述资源而产生任何索赔、赔偿、成本、损失及债务等，TI 对此概不负责，并且您须赔偿由此对TI 及其代表造成的损害。

TI 所提供产品均受TI 的销售条款 (<http://www.ti.com.cn/zh-cn/legal/termsofsale.html>) 以及ti.com.cn上或随附TI产品提供的其他可适用条款的约束。TI提供所述资源并不扩展或以其他方式更改TI 针对TI 产品所发布的可适用的担保范围或担保免责声明。

邮寄地址：上海市浦东新区世纪大道 1568 号中建大厦 32 楼，邮政编码：200122

Copyright © 2020 德州仪器半导体技术（上海）有限公司