

bq25871 集成 10 位 ADC 的 14V、7A、电池开关充电器

1 特性

- 适配器输入电压范围：3V 至 14V
 - 最高支持 14V 适配器电压
- 高度集成的 7A 电池开关
 - 集成金属氧化物半导体场效应晶体管 (MOSFET) 和电流感应功能
 - 低 $R_{DS(on)}$ (13mΩ) MOSFET，适用于在高电流条件下运行
- 集成有用于系统监视的高精度模数转换器 (ADC)
 - VBUS、VBAT、VOUT、VDROP 电压
 - 输入和电池电流
 - 电池和 VBUS 连接器温度
- 线性稳压 (LDO) 模式操作
 - 四个线性调节环路：IBUS、IBAT、VBAT 和 VOUT
 - 可编程线性稳压阈值
- 可编程安全保护
 - VBUS、VOUT 和 VBAT 过压保护 (OVP)
 - IBUS 和 IBAT 过流保护 (OCP)
 - IBUS 反向电流保护 (RCP)
 - VDROP (VBUS-VOUT) OVP
 - VBUS 连接器和电池热保护
 - 热关断
- 用于主机处理器警报的中断状态输出
- 高达 1Mhz 的 I²C 读写速度
- 仅电池模式下的电池泄漏电流较低
- 小型 WCSP 封装

2 应用

- 智能手机
- 平板电脑

3 说明

该器件是一款集成有 10 位 ADC 的 7A 电池开关充电器。该大电流电池开关充电器是一个具有反向电流阻断功能的 13mΩ MOSFET，设计用于提高效率并最大限度减小压降。高充电电流能力使得该器件成为智能手机、平板电脑和其他具有大电池容量的便携式设备的理想选择。

集成的 10 位 ADC 可以测量输入电压和电流、电池电压和电流，以及电池温度和输入连接器温度。这使得用户应用能够连续监视电力输入和电池充电参数，以确保电池充电的安全性。当电池进入恒定电流 (CC) 和恒定电压 (CV) 模式时，可以通过 I²C 寄存器灵活修改 VBUS、VOUT 和电池的 OVP 和 OCP 阈值。

该器件的 I²C 串行接口能以高达 1MHz 的速度工作，允许访问 ADC 对不同充电参数的测量结果，并且还允许对器件进行灵活的软件控制。INT 引脚可在发生故障时即刻向主机提供反馈。I²C 状态寄存器允许主机读取所有故障和事件的当前状态。

该器件采用 DSBGA 封装。

器件信息⁽¹⁾

器件型号	封装	封装尺寸 (标称值)
bq25871	YFF (42)	2.5mm x 3.1mm

(1) 要了解所有可用封装，请见数据表末尾的可订购产品附录。

简化电路原理图

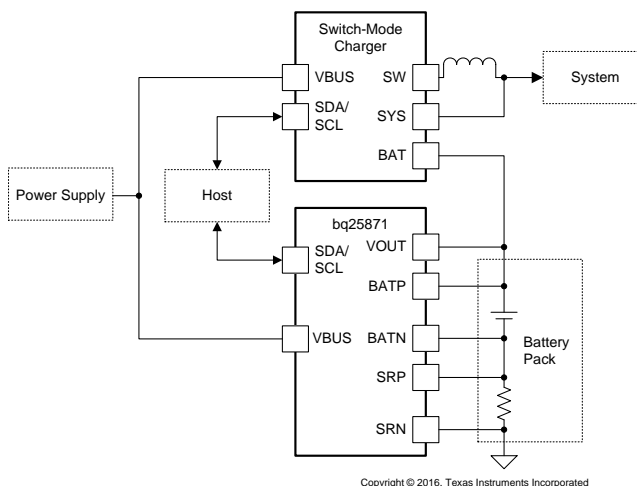

目录

1	特性	1	8.4	Device Functional Modes	27
2	应用	1	8.5	I ² C Register Maps	28
3	说明	1	9	Application and Implementation	56
4	修订历史记录	2	9.1	Application Information	56
5	Pin Configuration and Functions	3	9.2	Typical Application	56
6	Specifications	5	10	Power Supply Recommendations	59
6.1	Absolute Maximum Ratings	5	11	Layout	59
6.2	ESD Ratings	5	11.1	Layout Guidelines	59
6.3	Recommended Operating Conditions	6	11.2	Layout Example	59
6.4	Thermal Information	6	12	器件和文档支持	61
6.5	Electrical Characteristics	7	12.1	接收文档更新通知	61
6.6	Timing Requirements	12	12.2	社区资源	61
7	Typical Characteristics	13	12.3	商标	61
8	Detailed Description	15	12.4	静电放电警告	61
8.1	Overview	15	12.5	Glossary	61
8.2	Functional Block Diagram	16	13	机械、封装和可订购信息	62
8.3	Feature Description	17			

4 修订历史记录

日期	修订版本	注释
2016 年 10 月	*	最初发布。

5 Pin Configuration and Functions

**DSBGA Package
42 Pin YYF
Top View**

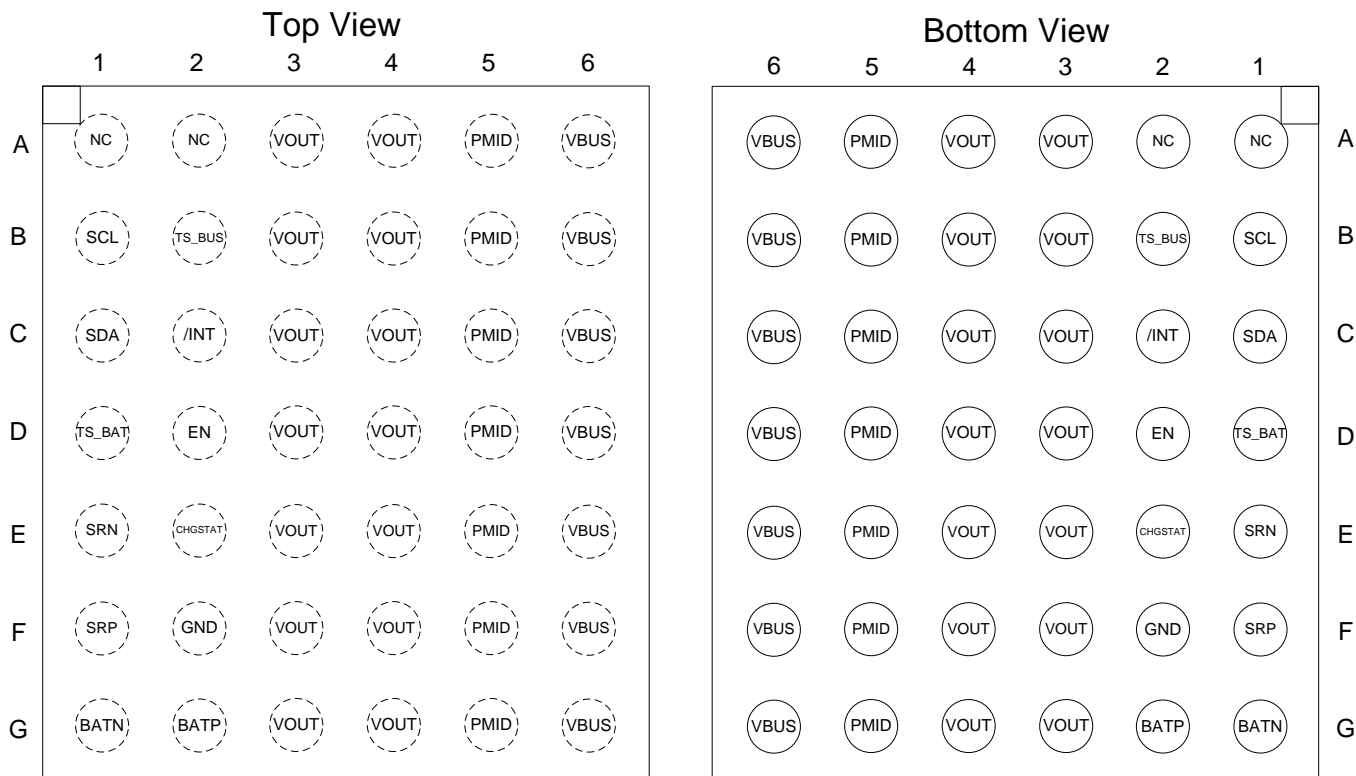

Pin Functions

PIN		I/O	DESCRIPTION
NAME	NO.		
VOUT	A3-G3, A4-G4	P	Device power output. Connected to the drain of Q2.
PMID	A5-G5	P	Tie pins to each other and leave floating. Do not connect to any other pins. Connected to the drain of Q1 and source of Q2.
TS_BUS	B2	AI	VBUS connector temperature qualification voltage input. Requires external resistor divider and voltage reference.
GND	F2	P	Device ground.
TS_BAT	D1	AI	Battery temperature qualification voltage input. Requires external resistor divider and voltage reference.
BATN	G1	AI	Negative input for battery voltage sensing. Connect to negative terminal of battery pack. Place 100-Ω/1-kΩ series resistance between pin and negative terminal.
BATP	G2	AI	Positive input for battery voltage sensing. Connect to positive terminal of battery pack. Place 100-Ω/1-kΩ series resistance between pin and positive terminal.
SRN	E1	AI	Negative input for battery current sensing. Place R _{SENSE} between SRN and SRP for battery current sensing.
SRP	F1	AI	Positive input for battery current sensing. Place R _{SENSE} between SRN and SRP for battery current sensing.
VBUS	A6, B6, C6, D6, E6, F6, G6	P	Device power input.
EN	D2	DI	Active high device enable. Pull low to disable device. ADC not available when device is disabled.
$\overline{\text{CHGSTAT}}$	E2	DI	Open drain, active low battery switch indicator. Connect to pull-up voltage via 10-kΩ pull-up resistor. This pin will assert low if battery switch is enabled and will go high when battery switch is disabled (due to fault or charge disabled or POR event).
$\overline{\text{INT}}$	C2	DO	Open drain, active low interrupt output. Connect to pull-up voltage via 10-kΩ pull-up resistor. Normally low, the $\overline{\text{INT}}$ pin asserts low to report status and faults. Keep constant low until the host reads this register 0x03, 0x04.
SDA	C1	DIO	I ² C interface data. Connect to pull-up voltage via 1-kΩ pull-up resistor.
SCL	B1	DI	I ² C interface clock. Connect to pull-up voltage via 1-kΩ pull-up resistor.
NC	A1, A2	AO	Not connected.

6 Specifications

6.1 Absolute Maximum Ratings

over operating free-air temperature range (unless otherwise noted)⁽¹⁾

		MIN	MAX	UNIT
Voltage range (with respect to GND)	VBUS (EN = Low, or CHG_EN = '0')	-2	22	V
	VOUT (EN = Low, or CHG_EN = '0')	-0.3	7	V
	SRP, SRN, BATP, BATN	-0.3	7	V
	$\overline{\text{INT}}$, SDA, SCL, EN, $\overline{\text{CHGSTAT}}$	-0.3	7	V
	TS_BUS, TS_BAT	-0.3	5	V
Maximum voltage difference	SRP – SRN	-0.5	0.5	V
	VOUT – VBUS	-22	7	V
Output sink current	$\overline{\text{INT}}$		6	mA
Operating free-air temperature range		-40	85	°C
Junction temperature, T _J		-40	150	°C
Storage temperature, T _{stg}		-65	150	°C

- (1) Stresses beyond those listed under *Absolute Maximum Ratings* may cause permanent damage to the device. These are stress ratings only, which do not imply functional operation of the device at these or any other conditions beyond those indicated under *Recommended Operating Conditions*. Exposure to absolute-maximum-rated conditions for extended periods may affect device reliability.

6.2 ESD Ratings

		VALUE	UNIT
V _(ESD) Electrostatic discharge	Human-body model (HBM), per ANSI/ESDA/JEDEC JS-001 ⁽¹⁾	±2000	V
	Charged-device model (CDM), per JEDEC specification JESD22-C101 ⁽²⁾	±500	V

- (1) JEDEC document JEP155 states that 500-V HBM allows safe manufacturing with a standard ESD control process.
(2) JEDEC document JEP157 states that 250-V CDM allows safe manufacturing with a standard ESD control process.

6.3 Recommended Operating Conditions

over operating free-air temperature range (unless otherwise noted)

		MIN	NOM	MAX	UNIT
V _{BUS}	EN = high, or CHG_EN = '1'	2.8		6	V
V _{OUT}	EN = high, or CHG_EN = '1'	2.8		6	V
BATP, BATN		0		6	V
SRP – SRN	Differential voltage between SRP and SRN	–0.2		0.2	V
TS _{BUS} , TS _{BAT}	TS pin voltage range	0		3	V
SDA, SCL, ADDR, INT, EN	TS pin voltage range	0		5	V
I _{OUT}	Maximum current from V _{BUS} to V _{OUT}	–3		7	A
T _J	Operating junction temperature range	–40		85	°C

6.4 Thermal Information

THERMAL METRIC ⁽¹⁾		bq25871	
		YFF (DSBGA)	
		42 PINS	
			UNIT
R _{θJA}	Junction-to-ambient thermal resistance	50.0	°C/W
R _{θJC(top)}	Junction-to-case (top) thermal resistance	0.2	°C/W
R _{θJB}	Junction-to-board thermal resistance	8.9	°C/W
ψ _{JT}	Junction-to-top characterization parameter	0.1	°C/W
ψ _{JB}	Junction-to-board characterization parameter	8.9	°C/W
R _{θJC(bot)}	Junction-to-case (bottom) thermal resistance	N/A	°C/W

- (1) For more information about traditional and new thermal metrics, see the *Semiconductor and IC Package Thermal Metrics* application report, [SPRA953](#).

6.5 Electrical Characteristics

Unless otherwise noted, the specification in the following table applies over operating ambient temperature range $-40\text{ }^{\circ}\text{C} \leq T_A \leq 85\text{ }^{\circ}\text{C}$. Typical values are for $T_A = 25\text{ }^{\circ}\text{C}$ (unless otherwise noted)

PARAMETER		TEST CONDITIONS	MIN	TYP	MAX	UNIT	
QUIESCENT CURRENTS							
I_{Q_OP}	VBUS operation quiescent current	ADC disabled (ADC_EN = 0), charge disabled (CHG_EN = 0), EN = low, $V_{VBUS} = 3.6\text{ V}$, VOUT floating, current into VBUS		100	125	μA	
		ADC enabled (ADC_EN = 1), charge disabled (CHG_EN = 0), EN = high, $V_{VBUS} = 3.6\text{ V}$, VOUT floating, current into VBUS		1.75	2.0	mA	
I_{Q_BAT}	Battery quiescent current	ADC disabled (ADC_EN = 0), charge disabled (CHG_EN = 0), EN = low, $V_{VOUT} = 3.6\text{ V}$, current into VOUT		20	30	μA	
		ADC disabled (ADC_EN = 0), charge disabled (CHG_EN = 0), EN = high, $V_{VOUT} = 3.6\text{ V}$, current into VOUT		80	120	μA	
		ADC enable (ADC_EN = 1), charge disabled (CHG_EN = 0), EN = high, $V_{VOUT} = 3.6\text{ V}$, current into VOUT		1.35	1.75	mA	
RESISTANCE AND LEAKAGE							
R_{ON}	VBUS to VOUT resistance	$V_{VBUS} = 3.6\text{ V}$, $T_A = 25\text{ }^{\circ}\text{C}$		13	16	$\text{m}\Omega$	
		$V_{VBUS} = 3.6\text{ V}$, $-40\text{ }^{\circ}\text{C} \leq T_A \leq 85\text{ }^{\circ}\text{C}$		13	22	$\text{m}\Omega$	
V_{VBUS_PD}	VBUS pull-down resistance	VBUS_PD_EN = '1'	0.5	1.0	1.35	$\text{k}\Omega$	
INTERNAL THRESHOLDS							
$V_{BUS_PRESENT}$	Rising				2.8	V	
	Falling hysteresis			120		mV	
V_{BAT_INSERT}	Rising				2.8	V	
	Falling hysteresis			120		mV	
T_{SHUT}	Internal thermal shutdown- rising			150		$^{\circ}\text{C}$	
T_{SHUT_HYS}	TSHUT falling hysteresis			30		$^{\circ}\text{C}$	
I_{RCP}	Current from VOUT to VBUS	RCP_SET = '0'	0.10	0.25	0.40	A	
		RCP_SET = '1'	2.75	3.00	3.25	A	
I_{SCP}	Short circuit current from VBUS to VOUT			10		A	
PROTECTION THRESHOLD and ACCURACY							
V_{DROP_OVP}	VDROP OVP range	VBUS – VOUT. Programmable range	0		1000	mV	
	VDROP OVP step size	$0\text{ mV} \leq \text{VDROP_OVP} \leq 640\text{ mV}$		10		mV	
		$700\text{ mV} < \text{VDROP_OVP} \leq 1000\text{ mV}$		100		mV	
	VDROP OVP comparator accuracy	VDROP_OVP = 80 mV	–8.0%		8.0%		
VDROP_OVP = 160 mV		–5.0%		5.0%			
V_{DROP_ALM}	VDROP ALM range	VBUS – VOUT. Programmable range	0		1000	mV	
	VDROP ALM step size	$0\text{ mV} \leq \text{VDROP_OVP} \leq 640\text{ mV}$		10		mV	
		$700\text{ mV} < \text{VDROOP_OVP} \leq 1000\text{ mV}$		100		mV	
	VDROP ALM comparator accuracy	VDROP_ALM = 80 mV	–8.0%		8.0%		
		VDROP_ALM = 160 mV	–5.0%		5.0%		
	VDROP ALM falling hysteresis			10		mV	

Electrical Characteristics (continued)

Unless otherwise noted, the specification in the following table applies over operating ambient temperature range $-40\text{ }^{\circ}\text{C} \leq T_A \leq 85\text{ }^{\circ}\text{C}$. Typical values are for $T_A = 25\text{ }^{\circ}\text{C}$ (unless otherwise noted)

PARAMETER		TEST CONDITIONS	MIN	TYP	MAX	UNIT	
V_{BUS_OVP}	VBUS OVP range	Programmable range	4.20		6.51	V	
	VBUS OVP step size			30		mV	
	VBUS OVP comparator accuracy	VBUS_OVP = 4.20 V		-1.25%		1.25%	
		VBUS_OVP = 4.50 V		-1.25%		1.25%	
		VBUS_OVP = 5.49 V		-1.25%		1.25%	
VBUS OVP falling hysteresis	VBUS_OVP = 4.20 V		50		mV		
I_{BUS_REG}	IBUS REG range	Programmable range	0		6.3	A	
	IBUS REG step size			100		mA	
	IBUS REG accuracy	IBUS_REG = 1.5 A, $-40\text{ }^{\circ}\text{C} \leq T_A \leq 85\text{ }^{\circ}\text{C}$		-20%		20%	
		IBUS_REG = 1.5 A, $T_A = 25\text{ }^{\circ}\text{C}$		-10%		10%	
I_{BUS_OCP}	IBUS OCP range	Programmable range	0		7.5	A	
	IBUS OCP step size			500		mA	
	IBUS OCP comparator accuracy	IBUS_OCP = 1.5 A		-20%		20%	
I_{BAT_REG}	IBAT REG range	Programmable range	0		6.35	A	
	IBAT REG step	$R_{sense} = 10\text{ m}\Omega$		50		mA	
	IBAT REG accuracy	IBAT_REG = 2 A, $R_{sense} = 10\text{ m}\Omega$		-6.5%		6.5%	
		IBAT_REG = 5 A, $R_{sense} = 10\text{ m}\Omega$		-4%		2%	
I_{BAT_OCP}	IBAT OCP rising threshold	Percentage of IBAT_REG threshold, IBAT_REG = 6 A		105%			
	IBAT OCP falling threshold	Percentage of IBAT_REG threshold, IBAT_REG = 6 A		102.5%			
V_{BAT_REG}	VBAT REG range	Programmable range	4.2		4.975	V	
	VBAT REG step size			12.5		mV	
	VBAT REG accuracy	VBAT_REG = 4.35 V		-1.5%		1.0%	
		VBAT_REG = 4.40 V		-1.5%		1.0%	
V_{BAT_OVP}	VBAT OVP rising threshold	Percentage of VBAT_REG threshold, VBAT_REG = 4.40 V		104%			
	VBAT OVP falling threshold	Percentage of VBAT_REG threshold, VBAT_REG = 4.40 V		102%			
V_{OUT_REG}	VOUT REG range	Programmable range	4.2		4.975	V	
	VOUT REG step size			25		mV	
	VOUT REG accuracy	VOUT_REG = 4.35 V		-0.5%		0.5%	
VOUT_REG = 4.40 V			-0.5%		0.5%		
V_{OUT_OVP}	VOUT OVP rising threshold	Percentage of VOUT_REG threshold, VOUT_REG = 4.40 V		104%			
	VOUT OVP falling threshold	Percentage of VOUT_REG threshold, VOUT_REG = 4.40 V		102%			
TS_{BUS_FLT}	TS_BUS pin voltage range	Programmable range	0.2		1.4	V	
	TS_BUS step size			25		mV	
	TS_BUS comparator accuracy	TS_BUS = 0.4 V		-4.0%		4.0%	
		TS_BUS = 0.7 V		-4.0%		4.0%	
TS_BUS hysteresis			1%				

Electrical Characteristics (continued)

Unless otherwise noted, the specification in the following table applies over operating ambient temperature range $-40\text{ }^{\circ}\text{C} \leq T_A \leq 85\text{ }^{\circ}\text{C}$. Typical values are for $T_A = 25\text{ }^{\circ}\text{C}$ (unless otherwise noted)

PARAMETER		TEST CONDITIONS	MIN	TYP	MAX	UNIT
TS _{BAT_FLT}	TS_BAT pin voltage range	Programmable range	0.2		1.4	V
	TS_BAT step size			25		mV
	TS_BAT comparator accuracy	TS_BAT = 0.4 V	-2.5%		2.5%	
		TS_BAT = 0.6 V	-2.5%		2.5%	
TS_BAT hysteresis			1%			

Electrical Characteristics (continued)

Unless otherwise noted, the specification in the following table applies over operating ambient temperature range $-40\text{ }^{\circ}\text{C} \leq T_A \leq 85\text{ }^{\circ}\text{C}$. Typical values are for $T_A = 25\text{ }^{\circ}\text{C}$ (unless otherwise noted)

PARAMETER		TEST CONDITIONS	MIN	TYP	MAX	UNIT
INTEGRATED ADC: temperature range: $0\text{ }^{\circ}\text{C} \leq T_A \leq 85\text{ }^{\circ}\text{C}$						
ADC _{RES}	Resolution				10	bits
t _{ADC_CONV}	ADC individual measurement and conversion time			30		μs
t _{ADC_INT}	ADC samples interval in averaging mode			300		μs
RANGE _{IBAT}	IBAT current measurement range		0		7.504	A
RES _{IBAT}	IBAT current LSB			8		mA
ACC _{IBAT}	IBAT accuracy	IBAT = 6 A	-2%		2%	
RANGE _{IBUS}	IBUS current measurement range		0		7.504	A
RES _{IBUS}	IBUS current LSB			8		mA
ACC _{IBUS}	IBUS accuracy	IBUS = 1.6 A	-5%		5%	
ACC _{IBUS}	IBUS accuracy	IBUS = 5 A	-4.5%		4.5%	
RANGE _{VBUS}	VBUS voltage measurement range		2.048		6.140	V
RES _{VBUS}	VBUS voltage LSB			4		mV
ACC _{VBUS}	VBUS accuracy	VBUS = 4.5 V	-20		20	mV
RANGE _{VBAT}	VBAT voltage measurement range		2.048		6.140	V
RES _{VBAT}	VBAT voltage LSB			4		mV
ACC _{VBAT}	VBAT accuracy	VBAT = 4.4 V	-12		12	mV
RANGE _{VOUT}	VOUT voltage measurement range		2.048		6.140	V
RES _{VOUT}	VOUT voltage LSB			4		mV
ACC _{VOUT}	VOUT accuracy	VOUT = 4.4 V	-12		12	mV
RANGE _{VDROP}	VDROP voltage measurement range		0		1000	mV
RES _{VDROP}	VDROP voltage LSB			1		mV
ACC _{VDROP}	VDROP accuracy	VDROP = 200 mV	-10		10	mV
RANGE _{TS_BUS}	TS_BUS voltage measurement range		0		2.420	V
RES _{TS_BUS}	TS_BUS voltage LSB			4		mV
ACC _{TS_BUS}	TS_BUS accuracy	TS_BUS = 400 mV	-13.4		13.4	mV
RANGE _{TS_BAT}	TS_BAT voltage measurement range		0		2.420	V
RES _{TS_BAT}	TS_BAT voltage LSB			4		mV
ACC _{TS_BAT}	TS_BAT accuracy	TS_BAT = 400 mV	-13.4		13.4	mV

Electrical Characteristics (continued)

Unless otherwise noted, the specification in the following table applies over operating ambient temperature range $-40\text{ }^{\circ}\text{C} \leq T_A \leq 85\text{ }^{\circ}\text{C}$. Typical values are for $T_A = 25\text{ }^{\circ}\text{C}$ (unless otherwise noted)

PARAMETER		TEST CONDITIONS	MIN	TYP	MAX	UNIT
LOGIC I/O THRESHOLD (EN, INT, ADDR)						
V_{IL}	Input low threshold level	$I_{SINK} = 5\text{ mA}$			0.4	V
V_{IH}	Input high threshold level	$I_{SINK} = 5\text{ mA}$	1.3			V
$I_{LEAK}(\overline{INT})$	High level leakage current	$V_{PULL-UP} = 3.3\text{ V}$			5	μA
$I_{LEAK}(\text{CHGSTAT})$	High level leakage current	$V_{PULL-UP} = 3.3\text{ V}$			5	μA
$I_{LEAK}(\text{EN})$	High level leakage current	$V_{PULL-UP} = 3.3\text{ V}$			10	μA
I²C TIMINGS						
V_{IL}	Input low threshold level	$V_{PULL-UP} = 1.8\text{ V}$, SDA and SCL			0.4	V
V_{IH}	Input high threshold level	$V_{PULL-UP} = 1.8\text{ V}$, SDA and SCL	1.3			V
V_{OL}	Output low threshold level	$I_{OL} = 20\text{ mA}$			0.4	V
I_{BIAS}	High-level leakage current	$V_{PULL-UP} = 1.8\text{ V}$, SDA and SCL			5	μA
f_{SCL}	SCL clock frequency				1	MHz

6.6 Timing Requirements

		MIN	NOM	MAX	UNIT
PROTECTION					
OSC	Oscillator frequency	1.8	2	2.4	MHz
t _{VBUS_OVP}	VBUS OVP deglitch time, VBUS_OVP_DLY = 0		8		μs
t _{VBUS_OVP}	VBUS OVP deglitch time, VBUS_OVP_DLY = 1		128		μs
t _{IBUS_OCP_BLANK}	IBUS OCP deglitch time, OCP_RES = 0		8		μs
t _{IBUS_OCP}	IBUS OCP deglitch time in hiccup mode, OCP_RES = 1		8		μs
t _{IBUS_OCP_HP}	Retry wait time for IBUS OCP in hiccup mode, OCP_RES = 1		100		ms
t _{IBUS_OCP_RST}	Hiccup count reset timer		400		ms
t _{IBAT_OCP}	IBAT OCP deglitch time		512		μs
t _{VDROP_OVP}	VDROP deglitch time		64		μs
t _{VBAT_OVP}	VBAT OVP deglitch time		64		μs
t _{VOUT_OVP}	VOUT OVP deglitch time		64		μs
t _{LDO_RES}	LDO response time for IBUS, IBAT, VBAT, VOUT		1		ms
t _{LDO_ACTIVE}	LDO active signal deglitch time		128		μs
T _{TS_OTP}	TS_BAT and TS_BUS deglitch time		100		ms
t _{REV}	Reverse current protection (RCP) deglitch time		8		μs
t _{SCP}	Short circuit protection (RCP) deglitch time		2		μs
t _{ON_VOUT}	VOUT soft-start rise time		0.5		ms
t _{OFF_FET}	Battery switch turn off time		1		μs
t _{WTDG}	Watchdog timer	WATCHDOG[3:2] = 01		0.5	s
		WATCHDOG[3:2] = 10		1	s
		WATCHDOG[3:2] = 11		2	s

7 Typical Characteristics

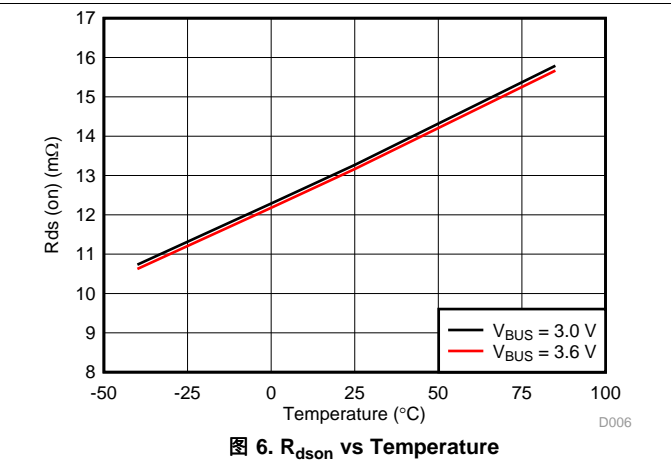
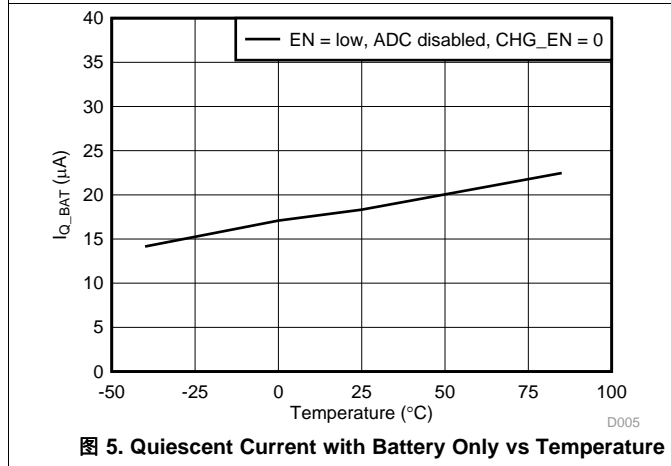
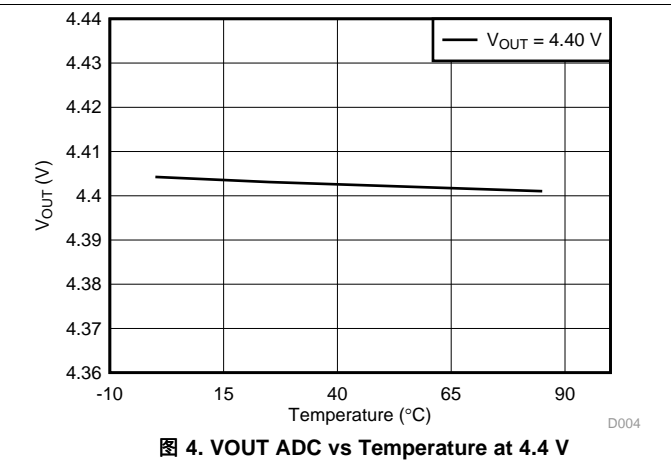
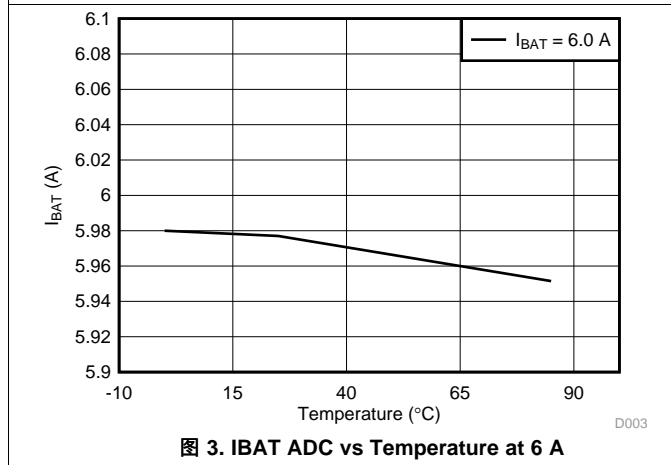
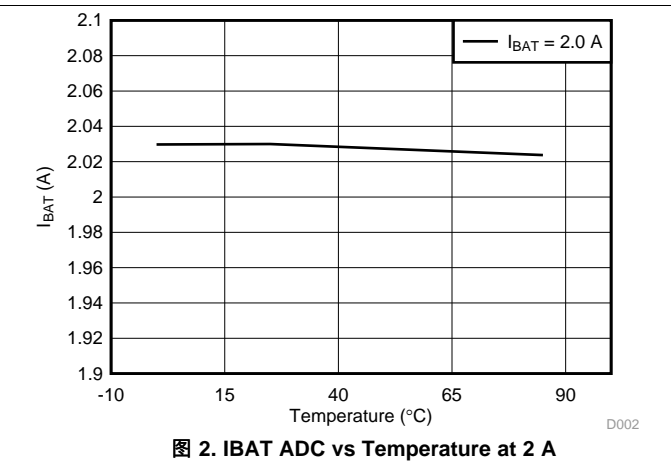
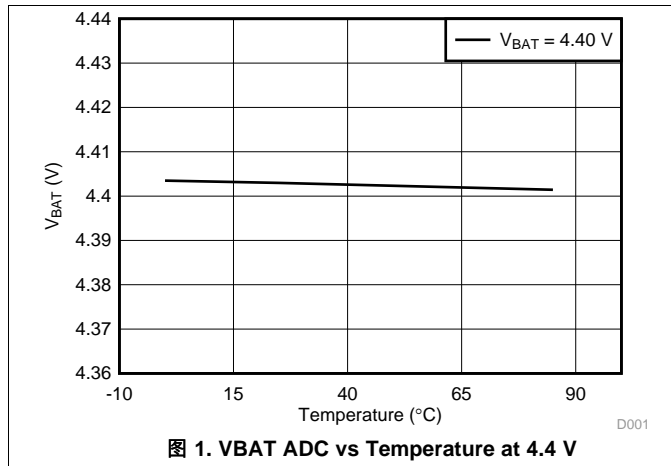

Typical Characteristics (接下页)

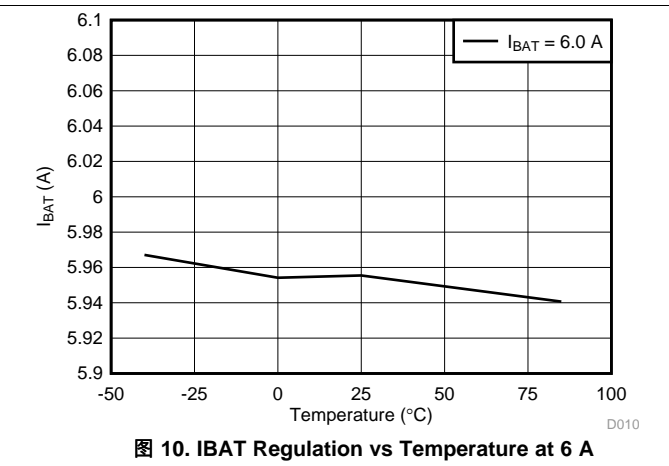
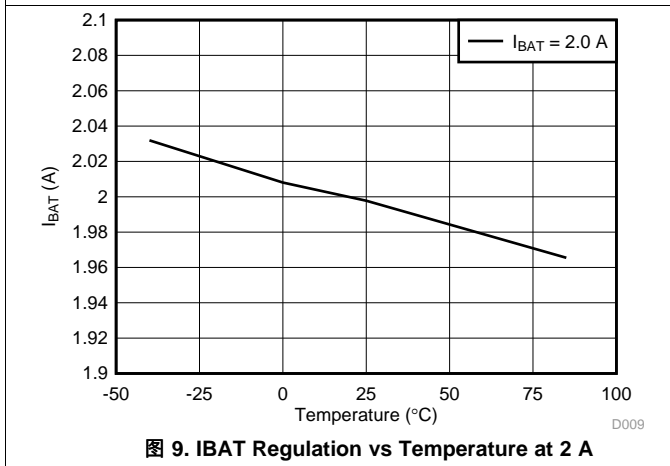
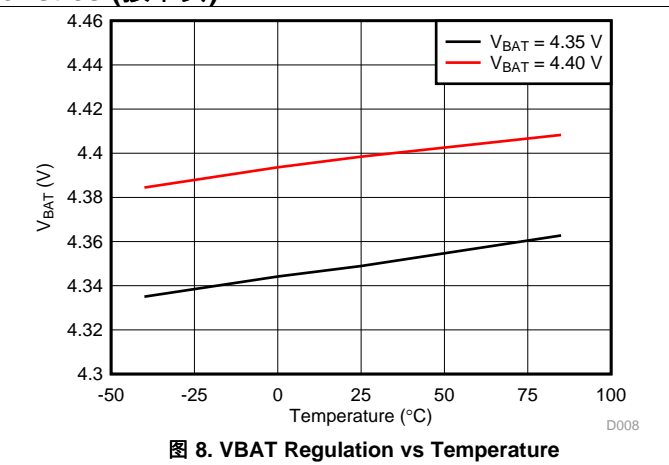
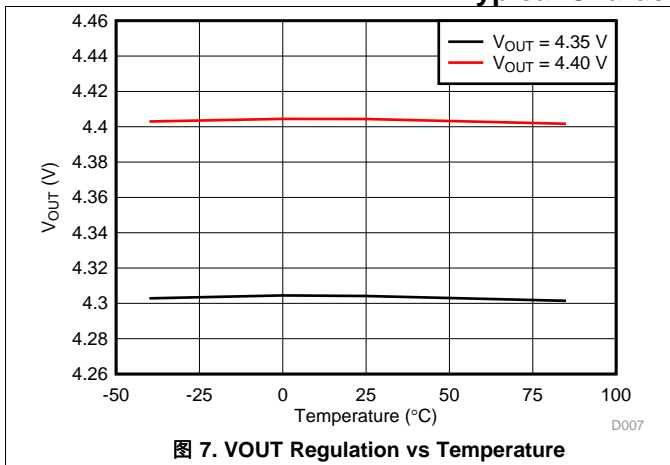

8 Detailed Description

8.1 Overview

The bq25871 is an I²C controlled device and a single cell Li-Ion battery charger. The device allows 7-A charging current with 13-mΩ MOSFETs for minimum power loss. A 10-bit ADC, four linear regulation loops and multiple OVP and OCP are integrated for host monitoring and safe operation of the device.

8.1.1 Device Protection Overview

The following table summarizes the protection features implemented in the device.

表 1. Protection Features Overview

PROTECTION NAME	DESCRIPTION	RESPOND
VBUS_OVP	Monitors VBUS voltage and compares to the threshold programmed in REG 0A	Turn off load switch after a deglitch time of t_{VBUS_OVP}
VOUT_REG	Monitors VOUT voltage and compares to the threshold programmed in REG 0B	Enable linear regulation of battery switch within a response time of t_{LDO_RES}
VOUT_OVP	Monitors VOUT voltage and compares to 1.04 times of the threshold programmed in REG 0B	Turn off load switch after a deglitch time of t_{VOUT_OVP}
VDROP_OVP	Monitors voltage difference between VBUS and VOUT (VBUS – VOUT) and compares to the threshold programmed in REG 0C	Turn off load switch after a deglitch time of t_{VDROP_OVP}
VDROP_ALM	Monitors voltage difference between VBUS and VOUT (VBUS – VOUT) and compares to the threshold programmed in REG 0D	\overline{INT} is asserted low to alert host
VBAT_REG	Monitors VBAT voltage and compares to the threshold programmed in REG 0E	Enable linear regulation of battery switch within a response time of t_{LDO_RES}
VBAT_OVP	Monitors VBAT voltage and compares to 1.04 times of the threshold programmed in REG 0E	Turn off load switch after a deglitch time of t_{VBAT_OVP}
IBAT_REG	Monitors battery current measured by sensing resistor and compares to the threshold programmed in REG 0F	Enable linear regulation of battery switch within a response time of t_{LDO_RES}
IBAT_OCP	Monitors VBAT voltage and compares to 1.05 times of the threshold programmed in REG 0E	Turn off load switch after a deglitch time of t_{VBAT_OVP}
IBUS_OCP	Monitors input current and compares to the threshold programmed in REG 09	Turn off load switch after a deglitch time of t_{IBUS_OCP}
IBUS_REG	Monitors input current and compares to the threshold programmed in REG 10	Enable linear regulation of battery switch within a response time of t_{LDO_RES}
IBUS_RCP	Monitors current flowing from battery to adaptor and compares to the threshold selected in REG 06	Turn off load switch after a deglitch time of t_{IBUS_RCP}
TS_BUS_OTP	Monitors temperature based on voltage measured by a negative temperature coefficient (NTC) resistor at VBUS and compares to the threshold programmed in REG 11	Turn off load switch after a deglitch time of t_{TS_OTP}
TS_BAT_OTP	Monitors temperature based on voltage measured by a negative temperature coefficient (NTC) resistor at battery and compares to the threshold programmed in REG 12	Turn off load switch after a deglitch time of t_{TS_OTP}

8.2 Functional Block Diagram

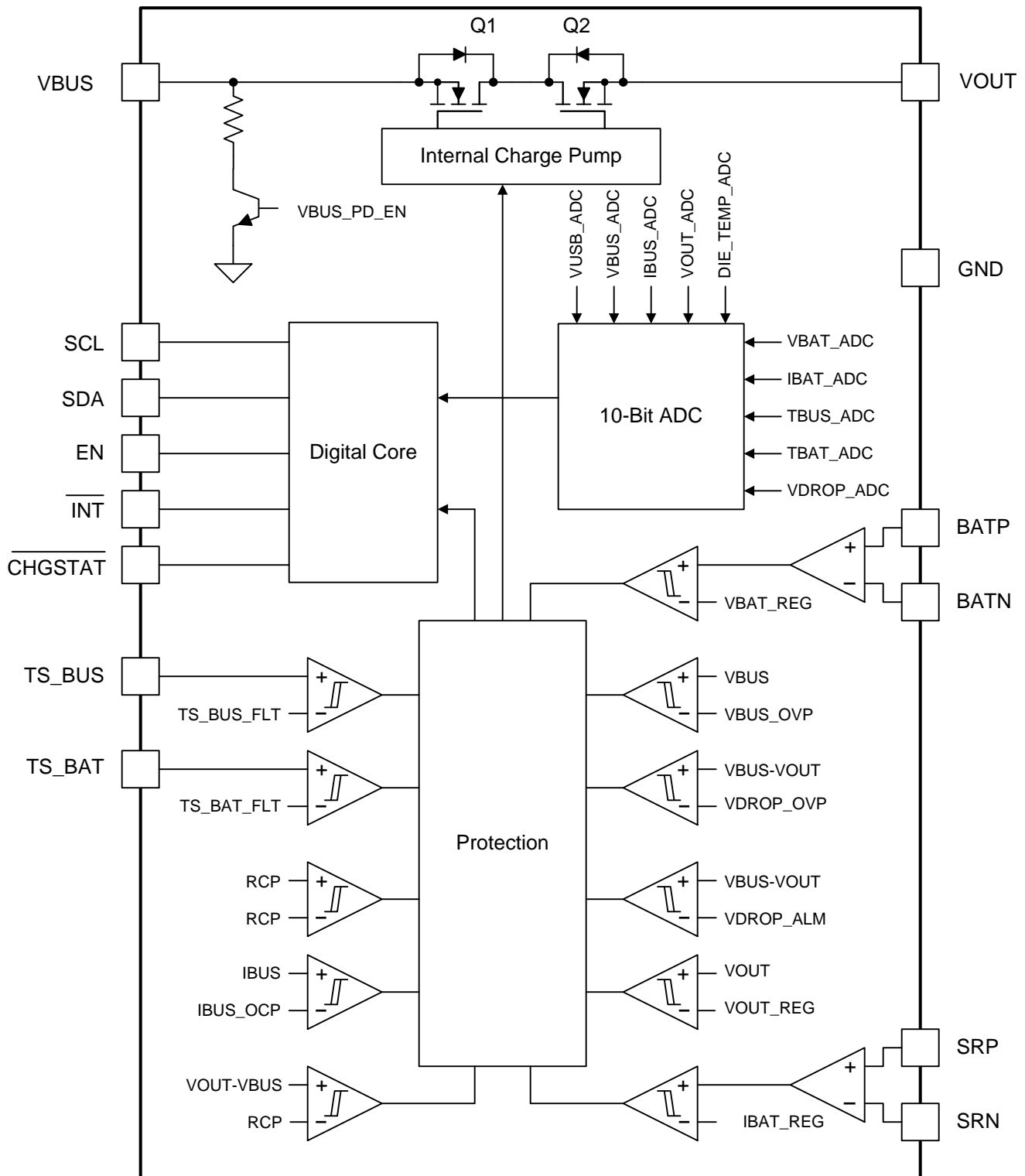

Copyright © 2016, Texas Instruments Incorporated

8.3 Feature Description

8.3.1 Device Power Up

The internal bias circuits of the device are powered from higher of the two voltages between VBUS and VOUT as long as one of the pins is above its respective PRESENT threshold ($V_{BUS_{PRESENT}}$, or $V_{OUT_{PRESENT}}$). Once either $V_{VBUS} > V_{BUS_{PRESENT}}$, or $V_{VOUT} > V_{OUT_{PRESENT}}$ is qualified, the device is considered to have a valid power supply. However, the device will begin to draw current from VBUS or VOUT (depending upon which supply is present) once either supply is above its respective UVLO threshold.

8.3.2 Battery Switch (Q1 + Q2)

The device contains an integrated 13mΩ battery switch that is capable of handling up to 7 A of current. This battery switch can be controlled by the host via CHG_EN I²C bit. The device can be disabled, including the battery switch and the I²C core, by pulling the EN pin low. To turn on the battery switch charger for conduction, the EN pin must be pulled high, CHG_EN bit must be set to '1', and no fault conditions must be present (unless they have been disabled in EVENT_1_EN register). See EVENT_1 and EVENT_2 registers for a list of faults/events. In the event of a fault/event, the battery switch will be automatically disabled, and the host will be notified via the INT for error reporting if the corresponding event bit is unmasked in the EVENT_x_MASK registers.

In order to ensure that the IBUS OCP threshold is not falsely tripped during turn-on of the battery switch, the device employs a soft-start scheme where the battery switch is slowly turned to minimize the inrush current. The rise time of VOUT is t_{ON_VOUT} .

8.3.3 Integrated 10-bit ADC for Monitoring

With the integrated 10-bit ADC of the device, the user application can monitor , the voltage and current of VBUS, voltage of VOUT , and the voltage and current of the battery. The ADC is also used for temperature reporting of the internal junction temperature, battery temperature (via external resistor divider and NTC thermistor), and VBUS connector temperature (via external resistor divider and NTC thermistor). The integrated ADC has a conversion time of t_{ADC_CONV} for each parameter (except IBAT_ADC which has conversion time of $2 \times t_{ADC_CONV}$). The total conversion time of all parameters (in 1-shot mode) is between 80 μs and 140 μs. The rate at which the ADC output registers are updated depends on the settings of ADC_AVG_EN, ADC_SAMPLES, and the parameter conversions that have been enabled in the ADC_MASK register.

To enable the ADC, the ADC_EN bit must be set to '1'. The ADC is allowed to operate if either $V_{VBUS} > V_{BUS_{PRESENT}}$ or $V_{VOUT} > V_{OUT_{PRESENT}}$ is valid. If ADC_EN is set to '1' before VBUS or VOUT reach their respective PRESENT threshold, then ADC conversion will be postponed until one of the power supplies reaches their respective PRESENT threshold. If EN pin is asserted low, then ADC conversion is not allowed.

The integrated ADC has two conversion rate options – 1-shot conversion (only one conversion) and continuous conversion (back-to-back conversions). To select the appropriate conversion rate, the ADC_RATE bit must be set accordingly ('0' for 1-shot, '1' for continuous). If ADC_AVG_EN is set to '0', the ADC will convert instantaneous measurements. If ADC_AVG_EN is set to '1', the average measurement of a parameter (in both continuous and 1-shot mode) will be determined by the setting of ADC_SAMPLES. If the user reads the output registers before the ADC averaging is complete, then the read-back value would be unchanged from the previous converted measurement. However, the value in the register will not change during the read-back of the register(s). If the measured signal is outside of the range of the ADC output register in question, the reported value in the ADC will be clamped to the min/max of the range specified. When ADC_EN is changed from 1 to 0, the ADC registers will maintain their values from the previous converted measurement.

Feature Description (接下页)

The user application has the option of selecting which parameters (voltage, current, temperature) the ADC needs to convert when the ADC is set to continuous conversion mode (ADC_RATE is set to '1') or in 1-shot mode (ADC_RATE is set to '0'). By default, all parameters (IBUS_ADC, VBUS_ADC, IBAT_ADC, VBAT_ADC, VOUT_ADC, VDROP_ADC, TBUS_ADC, TBAT_ADC, TDIE_ADC) will be converted in 1-shot and continuous conversion mode unless disabled in the ADC_MASK register. If an ADC parameter is masked (by setting the corresponding bit in the ADC_MASK_x register), then the value in that register will be from the last valid ADC conversion or the default POR value (which is all zeros if no conversions have taken place). If an ADC parameter is masked in the middle of an ADC measurement cycle, the device will finish the conversion of that parameter in the current conversion cycle and will not convert that parameter starting the next conversion cycle. Even though no conversion takes place when all ADC measurement parameters are masked off, the ADC circuitry is active and ready to begin conversion as soon as one of the bits in the ADC_MASK register is set to '0'.

The ADC_DONE bit signals when a 1-shot mode conversion is completed. During continuous conversion mode, this bit is always set to '0'.

The ADC_EN bit controls when the ADC is enabled for a conversion. Upon enabling the ADC, the ADC conversion will follow the settings in ADC_AVG_EN, ADC_SAMPLE, and ADC_RATE.

ADC conversion operates independently of the faults present in the device. ADC conversion will continue even after a fault has occurred (that causes the battery switch to be disabled), and the host must set ADC_EN = '0' to disable ADC.

ADC readings are only valid for DC states of the signals, not for transients.

8.3.4 Linear Regulation Mode (LDO)

The device employs LDO mode that helps regulate VOUT voltage, battery voltage, input current and battery current. In an event that the VOUT_REG, VBAT_REG, IBUS_REG or IBAT_REG threshold is exceeded, the battery switch will act as an LDO and will regulate VOUT, VBAT, IBUS and IBAT (depending upon which threshold is exceeded). The purpose of LDO mode is to provide temporary protection until the host is able to read the EVENT_x registers (upon $\overline{\text{INT}}$ trigger), ADC output registers, and then update the adapter voltage accordingly.

When VOUT_REG, VBAT_REG, or IBAT_REG threshold is exceeded, the response time of the LDO will be 1ms. Depending upon which LDO mode event occurs, the corresponding bit (VBAT_REG_LDO, IBAT_REG_LDO, VOUT_REG_LDO) will be set in EVENT_1 register and $\overline{\text{INT}}$ will be asserted low to alert the host (if the corresponding bit is not masked in EVENT_1_MASK register).

Feature Description (接下页)

8.3.5 Protection Features

The device contains various protection features that are active depending upon the states of various inputs:

- If $V_{VBUS} > V_{BUS_{PRESENT}}$, $V_{VOUT} > V_{OUT_{PRESENT}}$, EN asserted high, and CHG_EN = '1'
 - Active protection: VBUS_OVP, IBUS_OCP, VOUT_OVP, VBAT_OVP, IBAT_OCP, SCP, RCP, VDROPOVP
- If $V_{VBUS} > V_{BUS_{PRESENT}}$, $V_{VOUT} > V_{OUT_{PRESENT}}$, EN asserted high, and CHG_EN = '0'
 - Active protection: VBUS_OVP, IBUS_OCP, VOUT_OVP, IBAT_OCP, SCP, RCP, VDROPOVP
 - VBAT_OVP active until VBAT OVP condition is over (protection becomes inactive on falling threshold of VBAT_OVP, which is 102% of VBAT_REG setting)

Tripping any of these protection faults will cause the battery switch to be disabled (unless the protection is disabled in EVENT_1_EN and EVENT_2_EN registers) and an interrupt to be issued on the INT pin (see INT Pin, EVENT_x Registers, EVENT_x_MASK Registers section for details of when \overline{INT} is toggled).

8.3.5.1 Reverse Current Protection (RCP)

The device monitors the current flow from VBUS to VOUT to ensure there is no reverse current (current flow from VOUT to VBUS). In an event that a reverse current flow is detected, the battery switch is disabled within t_{OFF_FET} after a deglitch time of t_{IREV} and CHG_EN is set to '0'. Host intervention is required to set CHG_EN to '1' to enable the power switch again. The RCP threshold is set by the RCP_SET bit.

Reverse current protection is always active when the device has valid power. The RCP threshold is based on the RCP_SET bit setting in the CONTROL register. It has a response delay of t_{IREV} . When RCP is tripped, IBUS_IREV_FLT bit in the EVENT_1 register is set to '1', and \overline{INT} is asserted low to alert the host (unless masked by IBUS_IREV_MASK).

8.3.5.2 Internal Thermal Shutdown

The device monitors the die junction temperature and the battery switch is disabled when device junction temperature reaches TSHUT within t_{OFF_FET} and CHG_EN is set to '0'. When the internal thermal shutdown is triggered, \overline{INT} is asserted low to alert the host, and the device temperature must drop by TSHUT_HYS before the battery switch can be enabled again (host must enable battery switch). While the TSHUT condition persists (and before the junction temperature dropped by TSHUT_HYS), all other functions are unaffected.

If the DIE_TEMP_FLT threshold has been crossed, TSHUT_FLT bit in EVENT_2 register is set to '1', and \overline{INT} will assert low to alert the host (no mask bit for TSHUT_FLT). After the TSHUT_FLT is cleared by the host with a register read, it is possible the TSHUT_FLT bit is set again if the die junction temperature has not reduced by TSHUT_HYS.

DIE_TEMP_FLT allows the user to select TSHUT thresholds between different junction temperatures as the thermal shutdown point. DIE_TEMP_ADC is the die (junction) temperature of the device that is measured via the 10-bit ADC.

The ADC measurement (DIE_TEMP_ADC) is independent of the TSHUT fault that triggers TSHUT_FLT in the EVENT_x register. Therefore, it is possible to have the ADC output value be a higher value than the DIE_TEMP_FLT threshold, while the TSHUT fault has not yet been triggered.

Feature Description (接下页)

8.3.5.3 IBUS and VBUS Protection

Over-current protection on VBUS (IBUS_OCP) monitors the current flow from VBUS to VOUT pins. IBUS_OCP protection is always active when the battery switch is enabled, and the protection has a deglitch time that depends on the OCP_RES setting as described below.

If OCP_RES = '0' (blanking mode), the device will wait $t_{IBUS_OCP_BLANK}$ before disabling the battery switch within t_{OFF_FET} and setting CHG_EN to '0'. When the battery switch is disabled, IBUS_OCP_FLT is set to '1'. If during the $t_{IBUS_OCP_BLANK}$ duration a short circuit protection scenario occurs, then the device will follow the behavior as listed in short circuit protection (SCP). Once the battery switch is disabled, CHG_EN is set to '0' and host intervention is required to set CHG_EN to '1' to enable the battery switch again.



图 11. IBUS OCP and SCP

Feature Description (接下页)

If $OCP_RES = '1'$ (hiccup mode), the device will turn off the battery switch within t_{IBUS_OCP} and will attempt to turn on the battery switch every $t_{IBUS_OCP_HP}$, up to seven times before latching off the battery switch. Upon latching off after the seventh try, $IBUS_OCP_FLT$ is set to '1'. Once the battery switch is latched off, CHG_EN is set to '0' and host intervention is required to set CHG_EN to '1' to enable the battery switch again.

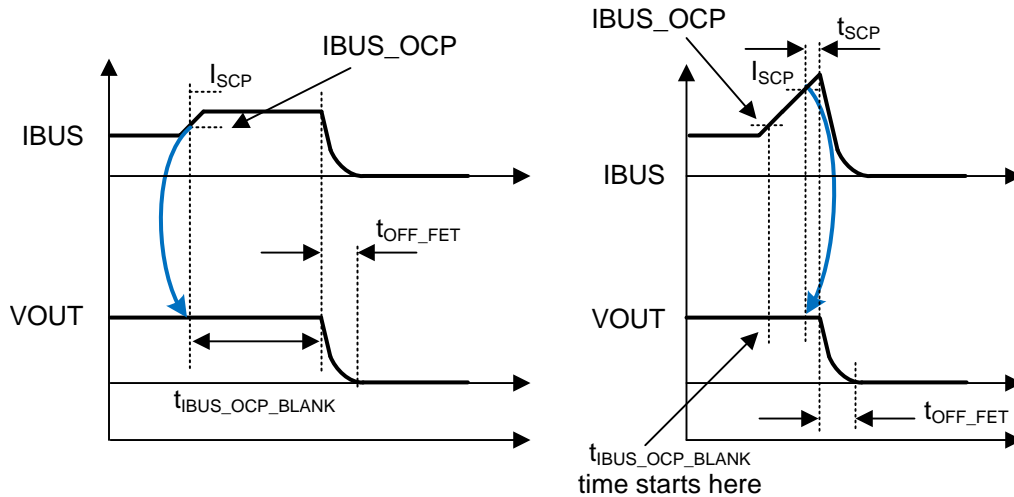

图 12. IBUS OCP in Hiccup Mode

VBUS over-voltage protection (VBUS_OVP) monitors the voltage on VBUS. VBUS_OVP protection is always active when the device voltage is above at least one PRESENT level (VBUS or VOUT), and the protection has a selectable deglitch time set by VBUS_OVP_DLY. When VBUS_OVP threshold is reached, the battery switch is turned off in t_{VBUS_OVP} and latched off. If the VBUS_OVP or IBUS_OCP value written to the register is greater than the max defined value for the register, then the corresponding register will be set to the highest defined value.

If a threshold has been crossed (IBUS_OCP or VBUS_OVP), the appropriate bit in the EVENT_1 register is updated (set to '1' if threshold is crossed, '0' if threshold is not crossed). If the EVENT_1_MASK bit is not set to '1' for the corresponding bit in the EVENT_1 register, then \overline{INT} will assert low to alert the host of a fault.

Feature Description (接下页)

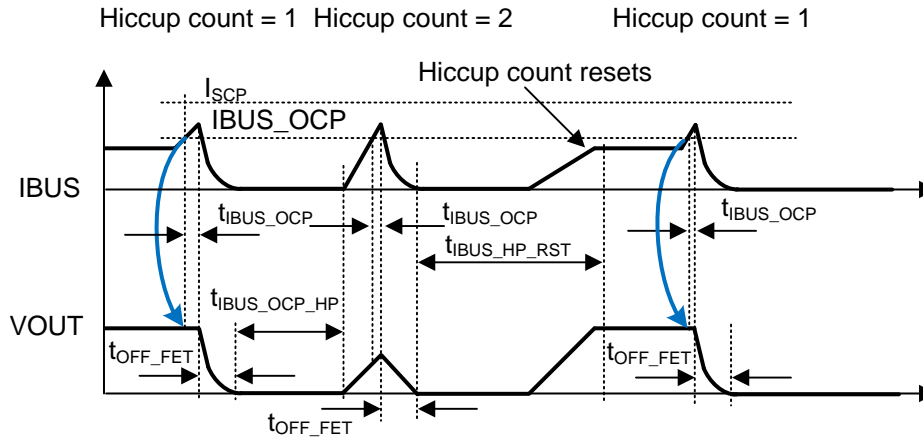
8.3.5.4 IBAT and VBAT Protection

The device monitors current through the battery by monitoring the voltage across the external, series battery sense resistor. The differential voltage of this sense resistor is measured on SRP and SRN. A 10-m Ω series resistor is recommended for battery current monitoring. A lower resistor value can be used, but it will result in lower measurement accuracy. A higher resistor value can be used, but it will result in decreased charging efficiency.

When the IBAT_REG threshold is reached, the device will go into LDO mode to regulate the battery current at the IBAT_REG threshold. See LDO mode section for more details about the device operation during LDO mode. If the IBAT_OCP threshold is reached and IBAT_OCP protection has been enabled, the battery switch will be disabled within $t_{\text{OFF_FET}}$ after a deglitch time of $t_{\text{IBAT_OCP}}$ and CHG_EN is set to '0'. Host intervention is required to set CHG_EN to '1' to enable the battery switch again.

The device monitors battery voltage by measuring the differential voltage on B ATP and B ATN pins. When the VBAT_REG threshold is reached, the device will go into LDO mode to regulate the battery voltage at the VBAT_REG threshold. See LDO mode section for more details about the device operation during LDO mode. If the VBAT_OVP threshold is reached and VBAT_OVP protection is enabled, the battery switch will be disabled within $t_{\text{OFF_FET}}$ after a deglitch time of $t_{\text{VBAT_OVP}}$ and CHG_EN is set to '0'. Host intervention is required to set CHG_EN to '1' to enable the battery switch again. If the VBAT_REG or IBAT_REG value written to the register is greater than the max defined value for the register, then the corresponding register will be set to the highest defined value.

If a threshold has been reached (IBAT_REG, VBAT_REG, IBAT_OCP or VBAT_OVP), the appropriate bit in the EVENT_x register is updated (set to '1' if threshold is crossed, '0' if threshold is not crossed). If the EVENT_x_MASK bit is not set to '1' for the corresponding bit in the EVENT_x register, then INT will assert low to alert the host of a fault.

8.3.5.5 VOUT Protection

The device monitors voltage on VOUT when the device has a valid power supply. When the VOUT_REG threshold is reached, the device will go into LDO mode to regulate the VOUT voltage at the VOUT_REG threshold. See LDO mode section for more details about the device operation during LDO mode. If the VOUT_OVP threshold is reached and VOUT_OVP protection is enabled, the battery switch will be disabled within $t_{\text{OFF_FET}}$ after a deglitch time of $t_{\text{VOUT_OVP}}$ and CHG_EN is set to '0'. Host intervention is required to set CHG_EN to '1' to enable the battery switch again. If the VOUT_REG value written to the register is greater than the max defined value for the register, then VOUT_REG will be set to the highest defined value for the register.

If a threshold has been reached (VOUT_REG or VOUT_OVP), the appropriate bit in the EVENT_1 register is updated (set to '1' if threshold is crossed, '0' if threshold is not crossed). If the EVENT_x_MASK bit is not set to '1' for the corresponding bit in the EVENT_x register, then INT will assert low to alert the host of a fault.

Feature Description (接下页)

8.3.5.6 VDROP Protection

VDROP is the voltage difference from VBUS to VOUT and can be used to monitor the health of MOSFET and power loss of the device. There are two VDROP thresholds, VDROP alarm (VDROP_ALM) and VDROP fault (VDROP_FLT). VDROP_ALM is an indicator (via I²C register bit and $\overline{\text{INT}}$) to alert the host that the voltage differential between VBUS and VOUT is higher than normal, and that the host should take action to reduce this drop. VDROP_OVP is a fault threshold that results in the battery switch being disabled within $t_{\text{OFF_FET}}$ after a deglitch time of $t_{\text{VDROP_OVP}}$ and CHG_EN set to '0' when VDROP_OVP protection is enabled. Host intervention is required to set CHG_EN to '1' to enable the battery switch again. If the VDROP_OVP or VDROP_ALM value written to the register is greater than the max defined value for the register, then the corresponding register will be set to the highest defined value.

If a threshold has been reached (VDROP_ALM or VDROP_OVP), the appropriate bit in the EVENT_1 register is updated (set to '1' if threshold is crossed, '0' if threshold is not crossed). If the EVENT_x_MASK bit is not set to '1' for the corresponding bit in the EVENT_x register, then $\overline{\text{INT}}$ will assert low to alert the host of a fault.

VDROP_ALM does not affect the state of the battery switch and only causes $\overline{\text{INT}}$ to assert low when the threshold is crossed. VDROP_OVP does turn off the battery switch and causes $\overline{\text{INT}}$ to assert low if this threshold is crossed. Therefore, if VDROP_ALM threshold is set higher than the VDROP_OVP threshold accidentally (user error), then VDROP_ALM functionality is never triggered since VDROP_OVP threshold will turn off the battery switch and assert $\overline{\text{INT}}$ low.

注

The threshold of VDROP_OVP and VDROP_ALM is around 13 mV lower than the actual setting when VDROP ADC is enabled.

8.3.5.7 VBUS Temperature (TS_BUS_FLT) and Battery Temperature (TS_BAT_FLT)

TBUS_OTP and TBAT_OTP protection is active whenever the device has a valid power supply. The purpose of VBUS temperature is to have connector temperature monitor to improve user experience. TS_BUS and TS_BAT both rely on a resistor divider that has an external pull-up voltage. Internally, the TS_BUS and TS_BAT pins are clamped to 2.42 V. Place a negative coefficient thermistor in parallel to the low-side resistor. A fault on the TS_BUS and TS_BAT pin is triggered on the falling edge of the voltage threshold (signifying a "hot" temperature).

If the TBUS_OTP or TBAT_OTP threshold is reached, the battery switch will be disabled within $t_{\text{OFF_FET}}$ after a deglitch time of $t_{\text{TS_OTP}}$ and CHG_EN is set to '0'. Host intervention is required to set CHG_EN to '1' to enable the battery switch again. If the TS_BUS_FLT or TS_BAT_FLT value written to the register is greater than the max defined value for the register, then the corresponding register will be set to the highest defined value.

For TS_BUS_FLT and TS_BAT_FLT, if a threshold has been crossed, the appropriate bit in the EVENT_x register is updated (set to '1' if threshold is crossed, '0' if threshold is not crossed). If the EVENT_x_MASK bit is not set to '1' for the corresponding bit in the EVENT_1 register, then $\overline{\text{INT}}$ will toggle to alert the host of a fault.

注

TS_BUS_FLT will not trip when TS_BUS ADC is enabled.

Feature Description (接下页)

8.3.6 I²C Serial Interface

The device uses I²C compatible interface for flexible charging parameter programming and instantaneous device status reporting. I²C communication to the device is available as long as $V_{VBUS} > V_{BUS_{UVLO}}$ or $V_{VOUT} > V_{OUT_{UVLO}}$. I²C™ is a bi-directional 2-wire serial interface developed by Philips Semiconductor (now NXP Semiconductors). Only two bus lines are required, a serial data line (SDA) and a serial clock line (SCL). Devices can be considered as masters or slaves when performing data transfers. A master is the device which initiates a data transfer on the bus and generates the clock signals to permit that transfer. At that time, any device addressed is considered a slave.

The device operates as a slave device with address set by the ADDR pin. The device receives control inputs from the master device like micro controller or a digital signal processor through REG00-REG29 and REG40. Register read between REG29 and REG39 beyond REG40 returns 0xFF. The I²C interface supports standard mode (up to 100 kbit/s), fast mode (up to 400 kbit/s), and fast mode plus (up to 1 Mbit/s). Connect the SDA and SCL pins to the positive supply voltage via a current source or pull-up resistor. When the bus is free, both lines are high. The SDA and SCL pins are open drain.

The device supports 7-bit addressing. The 8th bit will change depending upon the command (read or write) that is issued. The device's 7-bit address is defined as shown in the image below.



图 13. Slave Address

8.3.6.1 Data Validity

The data on the SDA line must be stable during the HIGH period of the clock. The HIGH or LOW state of the data line can only change when the clock signal on the SCL line is LOW. One clock pulse is generated for each data bit transferred.

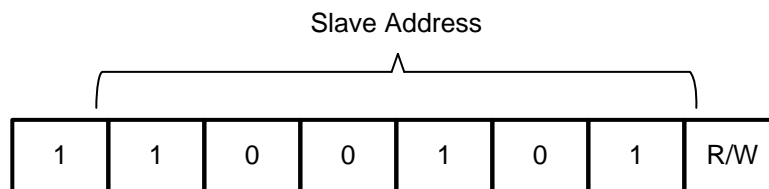

图 14. Bit Transfer on the I²C Bus

Feature Description (接下页)

8.3.6.2 START and STOP Conditions

All transactions begin with a START (S) and can be terminated by a STOP (P). A HIGH to LOW transition on the SDA line while SCL is HIGH defines a START condition. A LOW to HIGH transition on the SDA line when the SCL is HIGH defines a STOP condition.

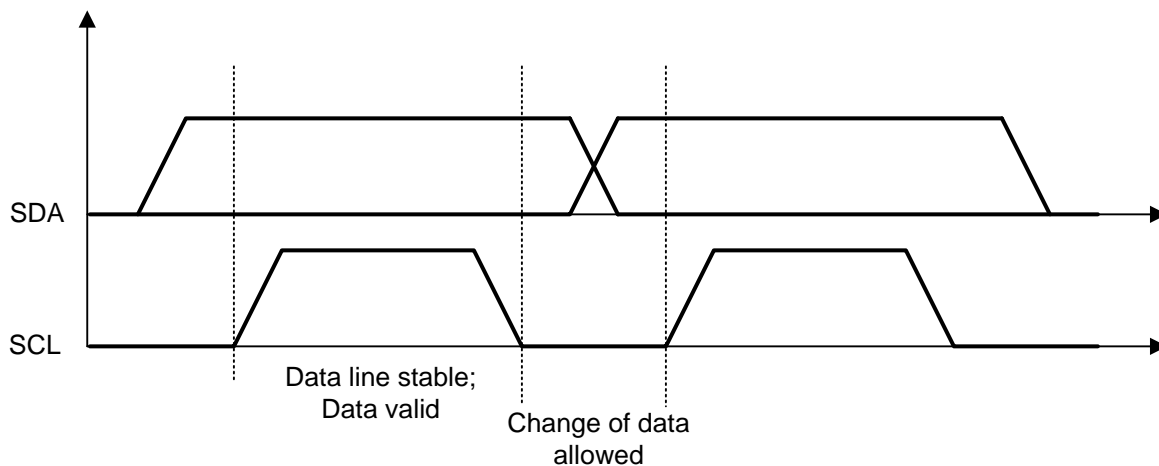
START and STOP conditions are always generated by the master. The bus is considered busy after the START condition, and free after the STOP condition.



图 15. START and STOP Conditions

8.3.6.3 Byte Format

Every byte on the SDA line must be 8 bits long. The number of bytes to be transmitted per transfer is unrestricted. Each byte has to be followed by an Acknowledge bit. Data is transferred with the Most Significant Bit (MSB) first. If a slave cannot receive or transmit another complete byte of data until it has performed some other function, it can hold the clock line SCL low to force the master into a wait state (clock stretching). Data transfer then continues when the slave is ready for another byte of data and release the clock line SCL.

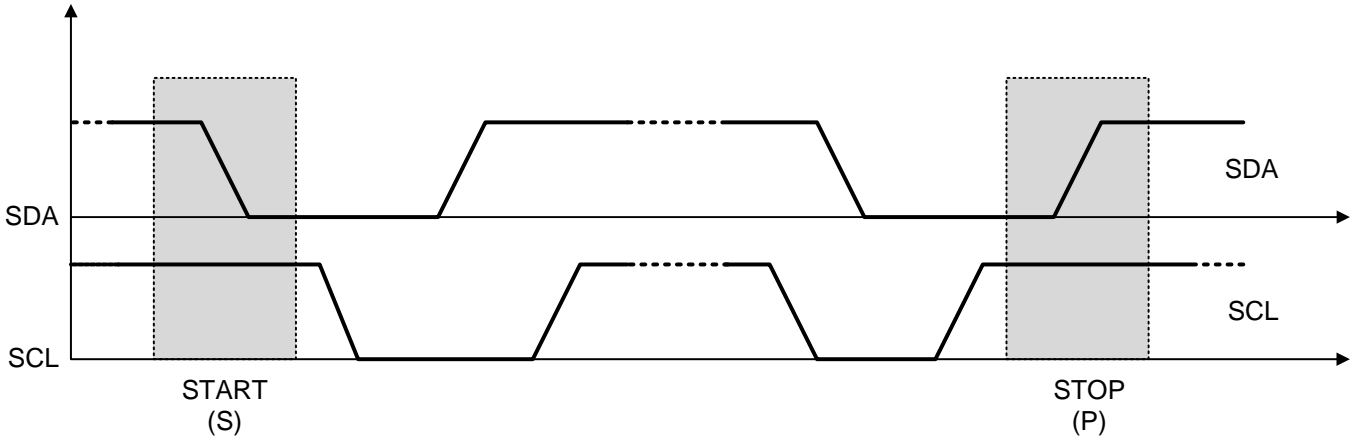

图 16. Data Transfer on the I²C Bus

8.3.6.4 Acknowledge (ACK) and Not Acknowledge (NACK)

The acknowledge takes place after every byte. The acknowledge bit allows the receiver to signal the transmitter that the byte was successfully received and another byte may be sent. All clock pulses, including the acknowledge 9th clock pulse, are generated by the master.

The transmitter releases the SDA line during the acknowledge clock pulse so the receiver can pull the SDA line LOW and it remains stable LOW during the HIGH period of this clock pulse.

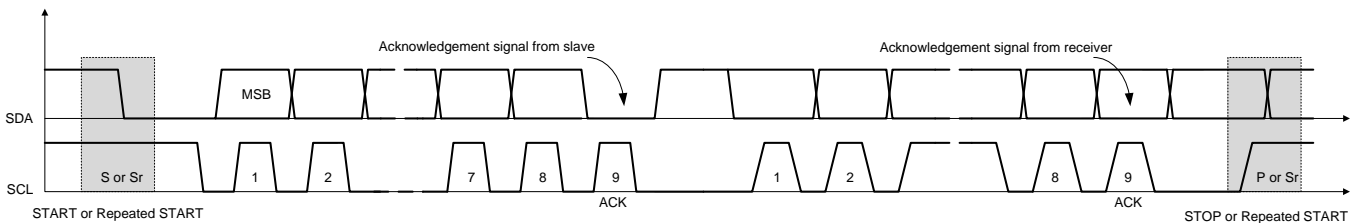
When SDA remains HIGH during the ninth clock pulse, this is the Not Acknowledge signal. The master can then generate either a STOP to abort the transfer or a repeated START to start a new transfer.

Feature Description (接下页)

8.3.6.5 Slave Address and Data Direction bit

After the START, a slave address is sent. This address is 7 bits long followed by the eighth bit as a data direction bit (bit R/W). A zero indicates a transmission (WRITE) and a one indicates a request for data (READ).



图 17. Complete Data Transfer



图 18. Single Read

If the register address is not defined, the charger device send back NACK and go back to the idle state.

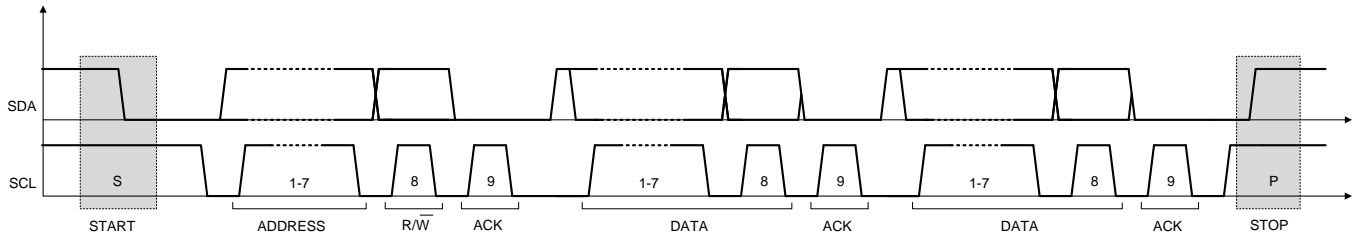
8.3.6.6 Multi-Read and Multi-Write

The charger device supports multi-read and multi-write on REG00 through REG08.

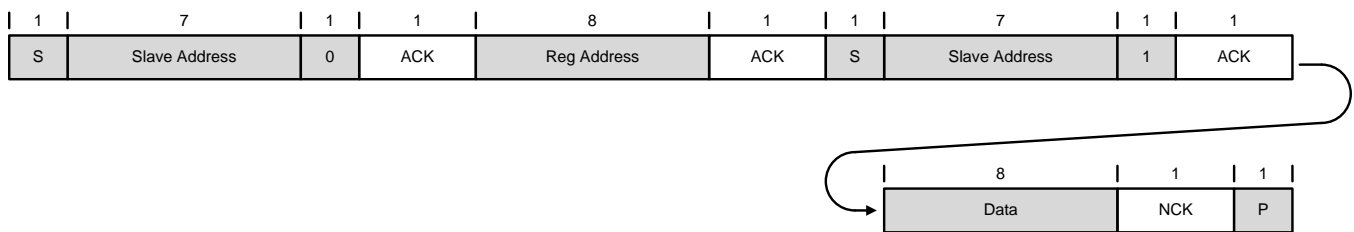

图 19. Multi-Read

EVENT_1, EVENT_2, and EVENT_3 keep all the information from last read until the host issues a new read. For example, if VBUS_OVP fault occurs but recovers later, the fault register EVENT_1 reports the fault when it is read the first time, but returns to normal when it is read the second time. In order to get the fault information at present, the host has to read EVENT_1, EVENT_2, and EVENT_3 for the second time.

8.4 Device Functional Modes

The device is a host controlled device. After power-on-reset, all the registers are in the default settings. All the device parameters can be programmed by the host. Writing 1 to REG 06 [0] will reset all registers to default setting. When watchdog timer expires, charge enable bit (REG06 [4]) and ADC enable bit (REG07 [3]) will be reset to default settings. To prevent watchdog timer expiring, the host has to read or write any register before the watchdog timer expires, or disable watchdog timer by setting REG06 [3:2] = 00.

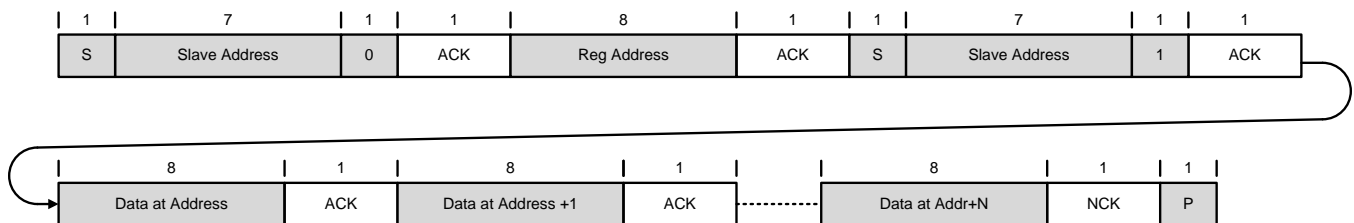

图 20. Operation Mode

8.5 I²C Register Maps

8.5.1 I²C Register Summary Table

表 2. I²C Register Summary Table

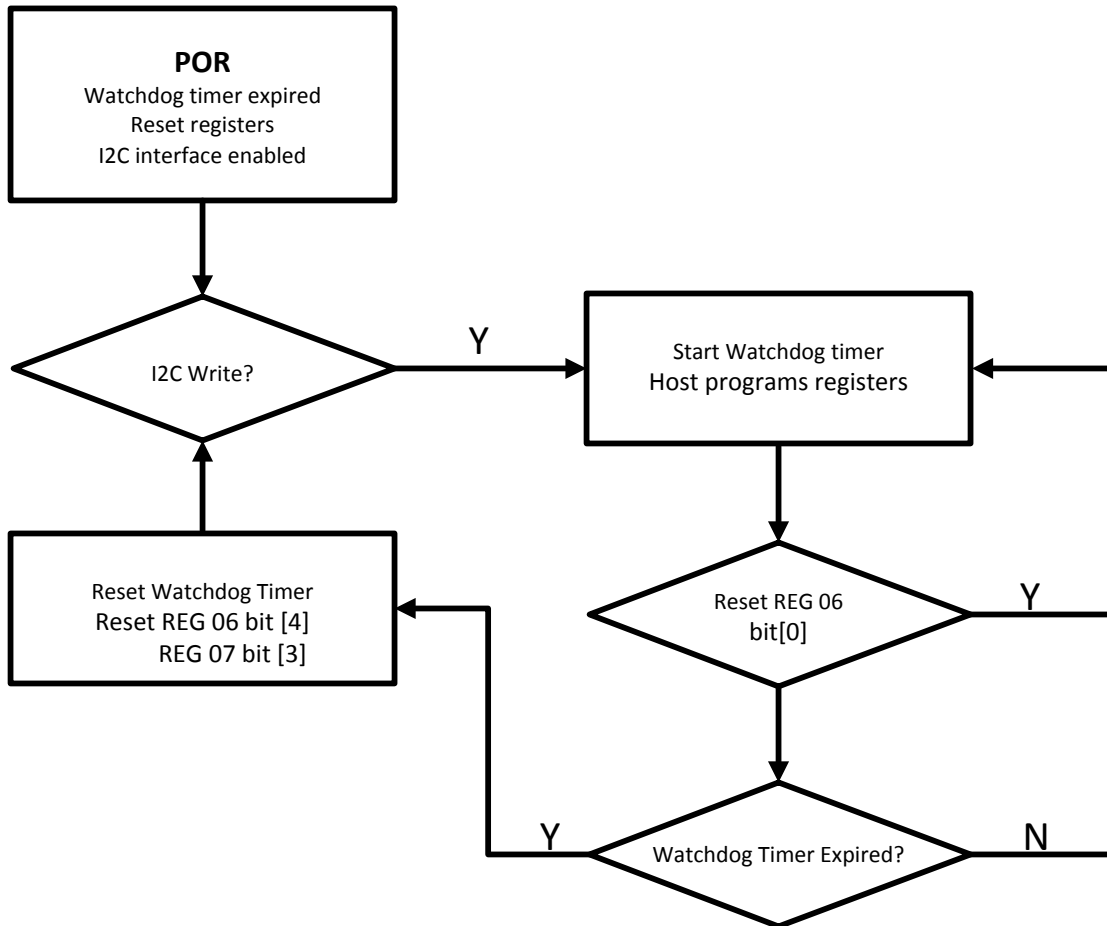
I ² C ADDRESS	R/W	REGISTER NAME	DESCRIPTION	POR STATE
0x00	R	DEVICE_INFO	Device rev and device ID	0x02
0x01	R/W	EVENT_1_MASK	Masks INT toggle of events in EVENT_1	0x00
0x02	R/W	EVENT_2_MASK	Masks INT toggle of events in EVENT_2	0x00
0x03	R	EVENT_1	First event register	0x00
0x04	R	EVENT_2	Second event register	0x00
0x05	R/W	EVENT_1_EN	Enables/disables protection in EVENT_1 register	0xFE
0x06	R/W	CONTROL	Settings for battery switch, watchdog, reset, and RCP threshold	0x2C
0x07	R/W	ADC_CTRL	Contains ADC control bits such as enable/disable, rate, and number of samples to take	0x87
0x08	R/W	ADC_MASK	Controls which parameters the ADC converts – first set	0xFF
0x09	R/W	PROTECTION	Deglintch setting and VBUS OCP threshold	0xA0
0x0A	R/W	VBUS_OVP	Sets VBUS OVP threshold	5.49 V
0x0B	R/W	VOUT_REG	Sets VOUT voltage regulation threshold	4.4 V
0x0C	R/W	VDROP_OVP	Sets the VDROP OVP threshold	300 mV
0x0D	R/W	VDROP_ALM	Sets the VDROP alarm threshold	100 mV
0x0E	R/W	VBAT_REG	Battery (BATP – BATN) regulation threshold	4.3 V
0x0F	R/W	IBAT_REG	Sets battery current regulation threshold	2 A
0x10	R/W	IBUS_REG	Sets VBUS REG threshold	5 A
0x11	R/W	TS_BUS_FLT	Sets VBUS temperature threshold	0.6 V
0x12	R/W	TS_BAT_FLT	Sets battery temperature threshold	0.7 V
0x13	R	VBUS_ADC	ADC output of VBUS voltage measurement	0x00
0x14	R			0x00
0x15	R	IBUS_ADC	ADC output of VBUS current measurement	0x00
0x16	R			0x00
0x17	R	VOUT_ADC	ADC output of VOUT voltage measurement	0x00
0x18	R			0x00
0x19	R	VDROP_ADC	ADC output of (VBUS – VOUT) voltage measurement	0x00
0x1A	R			0x00
0x1B	R	VBAT_ADC	ADC output of battery voltage measurement	0x00
0x1C	R			0x00
0x1D	R	IBAT_ADC	ADC output of battery current measurement	0x00
0x1E	R			0x00
0x1F	R	TBUS_ADC	ADC output of TS_BUS voltage	0x00
0x20	R			0x00
0x21	R	TBAT_ADC	ADC output of TS_BAT voltage	0x00
0x22	R			0x00
0x23	R	DIE_TEMP_ADC	ADC output of the die temperature	0x00
0x24	R/W	EVENT_3_EN	Enables/disables protection in EVENT_3 register	0x04
0x25	R/W	EVENT_3_MASK	Masks INT toggle of events in EVENT_3	0x00
0x26	R/W	EVNET_3	Third event register	0x00
0x29	R/W	CONTROL_2	Select location of IBAT sensing resistor	0x00
0x40	R/W	TDIE_TEMP_FLT	Setting die over temperature fault threshold	0x03

8.5.2 REG00 (DEVICE_INFO)

图 21. REG00 (DEVICE_INFO)

7	6	5	4	3	2	1	0
0	0	0	0	0	0	0	1
R	R	R	R	R	R	R	R

LEGEND: R/W = Read/Write; R = Read only; -n = value after reset

表 3. REG00 (DEVICE_INFO)

Bit	Field	Type	Reset			Description
			REG_RST	Watchdog	EN	
7	Reserved	R	N/A	N/A	N/A	Reserved bit. Always reads 0.
6	Reserved	R	N/A	N/A	N/A	Reserved bit. Always reads 0.
5	DEVICE_REV[2]	R	N/A	N/A	N/A	Device revision.
4	DEVICE_REV[1]	R	N/A	N/A	N/A	Device revision.
3	DEVICE_REV[0]	R	N/A	N/A	N/A	Device revision.
2	DEVICE_ID[2]	R	N/A	N/A	N/A	Device ID 010
1	DEVICE_ID[1]	R	N/A	N/A	N/A	
0	DEVICE_ID[0]	R	N/A	N/A	N/A	

8.5.3 REG01 (EVENT_1_MASK)
图 22. REG01 (EVENT_1_MASK)

7	6	5	4	3	2	1	0
0	0	0	0	0	0	0	0
R/W	R/W	R/W	R/W	R/W	R/W	R/W	R/W

LEGEND: R/W = Read/Write; R = Read only; -n = value after reset

表 4. REG01 (EVENT_1_MASK)

Bit	Field	Type	Reset			Description
			REG_RST	Watchdog	EN	
7	VBUS_OVP_MASK	R/W	Y	N	Y	VBUS over voltage fault mask 0 – no mask. $\overline{\text{INT}}$ will assert low when VBUS_OVP_FLT bit is set (default) 1 – VBUS_OVP_FLT is mask. $\overline{\text{INT}}$ will not assert low when VBUS_OVP_FLT is set.
6	LDO_ACTIVE_MASK	R/W	Y	N	Y	LDO active bit mask 0 – no mask. $\overline{\text{INT}}$ will assert low when LDO_ACTIVE bit is set (default) 1 – LDO_ACTIVE is mask. $\overline{\text{INT}}$ will not assert low when LDO_ACTIVE bit is set.
5	LDO_ACTIVE_MASK	R/W	Y	N	Y	LDO active bit mask 0 – no mask. $\overline{\text{INT}}$ will assert low when LDO_ACTIVE bit is set (default) 1 – LDO_ACTIVE is mask. $\overline{\text{INT}}$ will not assert low when LDO_ACTIVE is set.
4	LDO_ACTIVE_MASK	R/W	Y	N	Y	LDO active bit mask 0 – no mask. $\overline{\text{INT}}$ will assert low when LDO_ACTIVE bit is set (default) 1 – LDO_ACTIVE is mask. $\overline{\text{INT}}$ will not assert low when LDO_ACTIVE is set.
3	LDO_ACTIVE_MASK	R/W	Y	N	Y	LDO active bit mask 0 – no mask. $\overline{\text{INT}}$ will assert low when LDO_ACTIVE bit is set (default) 1 – LDO_ACTIVE is mask. $\overline{\text{INT}}$ will not assert low when LDO_ACTIVE is set.
2	TS_BUS_FLT_MASK	R/W	Y	N	Y	VBUS over temperature fault mask 0 – no mask. $\overline{\text{INT}}$ will assert low when TS_BUS_FLT bit is set (default) 1 – TS_BUS_FLT is mask. $\overline{\text{INT}}$ will not assert low when TS_BUS_FLT is set.
1	TS_BAT_FLT_MASK	R/W	Y	N	Y	VBUS over temperature fault mask 0 – no mask. $\overline{\text{INT}}$ will assert low when TS_BAT_FLT bit is set (default) 1 – TS_BAT_FLT is mask. $\overline{\text{INT}}$ will not assert low when TS_BAT_FLT is set.
0	IBUS_REV_MASK	R/W	Y	N	Y	IBUS reverse current fault mask 0 – no mask. $\overline{\text{INT}}$ will assert low when IBUS_REV bit is set (default) 1 – IBUS_REV is mask. $\overline{\text{INT}}$ will not assert low when IBUS_REV is set.

8.5.4 REG02 (EVENT_2_MASK)
图 23. REG02 (EVENT_2_MASK)

7	6	5	4	3	2	1	0
0	0	0	0	0	0	0	0
R	R/W	R/W	R/W	R/W	R/W	R	R/W

LEGEND: R/W = Read/Write; R = Read only; -n = value after reset

表 5. REG02 (EVENT_2_MASK)

Bit	Field	Type	Reset			Description
			REG_RST	Watchdog	EN	
7	Reserved	R	N/A	N/A	N/A	Reserved bit. Always reads 0.
6	ADC_DONE_MASK	R/W	Y	N	Y	ADC_DONE bit mask 0 – no mask. \overline{INT} will assert low when ADC_DONE bit is set (default) 1 – ADC_DONE is mask. \overline{INT} will not assert low when ADC_DONE bit is set.
5	VDROP_ALM_MASK	R/W	Y	N	Y	VDROP_ALM event mask 0 – no mask. \overline{INT} will assert low when VDROP_ALM bit is set (default) 1 – VDROP_ALM is mask. \overline{INT} will not assert low when VDROP_ALM bit is set.
4	VDROP_OVP_MASK	R/W	Y	N	Y	VDROP_OVP event mask 0 – no mask. \overline{INT} will assert low when VDROP_OVP bit is set (default) 1 – VDROP_OVP is mask. \overline{INT} will not assert low when VDROP_OVP is set.
3	VBUS_INSERT_MASK	R/W	Y	N	Y	VBUS_INSERT mask 0 – no mask. \overline{INT} will assert low when VBUS_INSERT bit is set (default) 1 – VBUS_INSERT is mask. \overline{INT} will not assert low when VBUS_INSERT is set.
2	BAT_INSERT_MASK	R/W	Y	N	Y	BAT_INSERT mask 0 – no mask. \overline{INT} will assert low when BAT_INSERT bit is set (default) 1 – BAT_INSERT is mask. \overline{INT} will not assert low when BAT_INSERT is set.
1	Reserved	R	N/A	N/A	N/A	Reserved bit. Always reads 0.
0	IBUS_OCP_MASK	R/W	Y	N	Y	IBUS over current fault mask 0 – no mask. \overline{INT} will assert low when IBUS_OCP bit is set (default) 1 – IBUS_OCP is mask. \overline{INT} will not assert low when IBUS_OCP is set.

8.5.5 REG03 (EVENT_1)
图 24. REG03 (EVENT_1)

7	6	5	4	3	2	1	0
0	0	0	0	0	0	0	0
R	R	R	R	R	R	R	R

LEGEND: R/W = Read/Write; R = Read only; -n = value after reset

表 6. 6.4.5 REG03 (EVENT_1)

Bit	Field	Type	Reset			Description
			REG_RST	Watchdog	EN	
7	VBUS_OVP_FLT	R	Y	N	Y	VBUS over voltage fault. This bit is set when VBUS voltage exceeds the limit set in VBUS_OVP register 0 – no fault (default) 1 – VBUS OVP fault
6	LDO_ACTIVE	R	Y	N	Y	Indicates if the device is in LDO mode 0 – not in LDO mode (default) 1 – in LDO mode
5	LDO_ACTIVE	R	Y	N	Y	Indicates if the device is in LDO mode 0 – not in LDO mode (default) 1 – in LDO mode
4	LDO_ACTIVE	R	Y	N	Y	Indicates if the device is in LDO mode 0 – not in LDO mode (default) 1 – in LDO mode
3	LDO_ACTIVE	R	Y	N	Y	Indicates if the device is in LDO mode 0 – not in LDO mode (default) 1 – in LDO mode
2	TS_BUS_FLT	R	Y	N	Y	VBUS over temperature fault. This bit is set when TS_BUS voltage falls below the limit set in TS_BUS_register. Battery switch is disabled. 0 – no fault (default) 1 – VBUS over temperature fault
1	TS_BAT_FLT	R	Y	N	Y	Battery over temperature fault. This bit is set when TS_BAT voltage falls below the limit set in TS_BAT_register. Battery switch is disabled. 0 – no fault (default) 1 – VBAT over temperature fault
0	IBUS_IREV_FLT	R	Y	N	Y	IBUS reverse current fault. This bit is set when current from VOUT to VBUS is detected. Battery switch is disabled. 0 – no fault (default) 1 – IBUS reverse current fault

8.5.6 REG04 (EVENT_2)

图 25. REG04 (EVENT_2)

7	6	5	4	3	2	1	0
0	0	0	0	0	0	0	0
R	R	R	R	R	R	R	R

LEGEND: R/W = Read/Write; R = Read only; -n = value after reset

表 7. REG04 (EVENT_2)

Bit	Field	Type	Reset			Description
			REG_RST	Watchdog	EN	
7	Reserved	R	N/A	N/A	N/A	Reserved bit. Always reads 0.
6	ADC_DONE.	R	Y	N	Y	Indicates if ADC conversion is complete for the required parameters in 1-shot mode only. This bit will change to '0' when an ADC conversion is requested in 1-shot mode, and it will change back to '1' when the conversion is complete. During continuous conversion mode, this bit will be '0'. 0 – conversion not complete (default) 1 – conversion complete
5	VDROP_ALM	R	Y	N	Y	Indicates if VDROP_ALM threshold is reached 0 – no fault (default) 1 – VDROP_ALM fault
4	VDROP_OVP_FLT	R	Y	N	Y	Indicates if VDROP_OVP threshold is reached. Battery switch is disabled. 0 – no fault (default) 1 – VDROP_OVP fault
3	VBUS_INSERT	R	Y	N	Y	Indicates if VBUS is detected. \INT toggles when VBUS is inserted but does not toggle when VBUS is removed. 0 – VBUS not inserted (default) 1 – VBUS inserted
2	BAT_INSERT	R	Y	N	Y	Indicates if battery is detected. \INT toggles when battery is inserted but does not toggle when battery is removed. 0 – Battery not inserted (default) 1 – Battery inserted
1	TSHUT_FLT	R/W	Y	N	Y	IC thermal shutdown indicator. Battery switch is disabled. 0 – no fault (default) 1 – IC thermal shutdown fault
0	IBUS_OCP_FLT	R/W	Y	N	Y	IBUS over current fault. This bit is set when IBUS exceeds IBUS_OCP register. Battery switch is disabled. 0 – no fault (default) 1 – IBUS over current fault

8.5.7 REG05 (EVENT_1_EN)
图 26. REG05 (EVENT_1_EN)

7	6	5	4	3	2	1	0
1	1	1	1	1	1	1	0
R/W	R/W	R/W	R/W	R/W	R/W	R/W	R/W

LEGEND: R/W = Read/Write; R = Read only; -n = value after reset

表 8. REG05 (EVENT_1_EN)

Bit	Field	Type	Reset			Description
			REG_RST	Watchdog	EN	
7	VBUS_OVP_EN	R/W	Y	N	Y	Enables VBUS_OVP protection 0 – disable VBUS_OVP protection 1 – enable VBUS_OVP protection (default)
6	IBUS_REG_EN	R/W	Y	N	Y	Enable IBUS regulation 0 – disable IBUS regulation 1 – enable IBUS regulation (default)
5	VBAT_REG_EN	R/W	Y	N	Y	Enable VBAT regulation 0 – disable VBAT regulation 1 – enable VBAT regulation (default)
4	IBAT_REG_EN	R/W	Y	N	Y	Enable IBAT regulation 0 – disable IBAT regulation 1 – enable IBAT regulation (default)
3	VOUT_REG_EN	R/W	Y	N	Y	Enable VOUT regulation 0 – disable VOUT regulation 1 – enable VOUT regulation (default)
2	TS_BUS_FLT_EN	R/W	Y	N	Y	Enable TS_BUS protection 0 – disable TS_BUS protection 1 – enable TS_BUS protection (default)
1	TS_BAT_FLT_EN	R/W	Y	N	Y	Enable TS_BAT protection 0 – disable TS_BAT protection 1 – enable TS_BAT protection (default)
0	VBUS_PD_EN	R/W	Y	N	Y	Enable the VBUS pull-down resistor (RVBUS_PD) 0 – disable RVBUS_PD (default) 1 – enable RVBUS_PD

8.5.8 REG06 (CONTROL)

图 27. REG06 (CONTROL)

7	6	5	4	3	2	1	0
0	0	1	0	0	1	0	0
R/W	R/W	R/W	R/W	R/W	R/W	R/W	R/W

LEGEND: R/W = Read/Write; R = Read only; -n = value after reset

表 9. REG06 (CONTROL)

Bit	Field	Type	Reset			Description
			REG_RST	Watchdog	EN	
7	VDROP_OVP_EN	R/W	Y	N	Y	Enables VDROP_OVP protection 0 – disable VDROP_OVP protection (default) 1 – enable VDROP_OVP protection
6	VDROP_ALM_EN	R/W	Y	N	Y	Enables VDROP_ALM protection 0 – disable VDROP_ALM protection (default) 1 – enable VDROP_ALM protection
5	SENSE_R	R/W	Y	N	Y	Select the sense resistor value between SRP and SRN 0 – 5 mΩ 1 – 10 mΩ (default)
4	CHG_EN	R/W	Y	Y	Y	Software bit for charge enable. This enables the battery switch. This bit will set to '0' if any fault causes the battery switch to be disabled. 0 – charge disabled (default) 1 – charge enabled
3	WATCHDOG[1]	R/W	Y	N	Y	Watchdog timer setting 00 – disable watchdog timer 01 – 0.5 s 10 – 1.0 s (default) 11 – 2 s
2	WATCHDOG[0]	R/W	Y	N	Y	
1	RCP_SET	R/W	Y	N	Y	Reverse current protection (RCP) threshold setting 0 – RCP set to 0 A (default) 1 – RCP set to -3 A
0	REG_RST	R/W	Y	N	Y	Register reset 0 – no reset (default) 1 – reset all registers to default values

8.5.9 REG07 (ADC_CONTROL)
图 28. REG07 (ADC_CONTROL)

7	6	5	4	3	2	1	0
1	0	0	0	0	1	1	1
R/W	R	R	R	R/W	R/W	R/W	R/W

LEGEND: R/W = Read/Write; R = Read only; -n = value after reset

表 10. REG07 (ADC_CONTROL)

Bit	Field	Type	Reset			Description
			REG_RST	Watchdog	EN	
7	TDIE_ADC_EN	R/W	Y	N	Y	Enable/ disable conversion of die junction temperature 0 – disable conversion 1 – enabled conversion (default)
6	Reserved	R	Y	N	Y	Reserved bit. Always read 0.
5	Reserved	R	Y	N	Y	Reserved bit. Always read 0.
4	Reserved	R	Y	N	Y	Reserved bit. Always read 0.
3	ADC_EN	R/W	Y	Y	Y	Enable/ disable ADC 0 – disable ADC (default) 1 – enable ADC
2	ADC_RATE	R/W	Y	N	Y	Set ADC conversion rate 0 – 1-shot conversion 1 – continuous conversion (default)
1	ADC_AVG_EN	R/W	Y	N	Y	Enable/disable ADC measurement averaging 0 – disable averaging, instantaneous measurement 1 – enable averaging (default)
0	ADC_SAMPLES	R/W	Y	N	Y	Set the number of samples to be taken for an ADC conversion 0 – 8 samples taken for averaging 1 – 16 samples taken for averaging (default)

8.5.10 REG08 (ADC_EN)
图 29. REG08 (ADC_EN)

7	6	5	4	3	2	1	0
1	1	1	1	1	1	1	1
R/W	R/W	R/W	R/W	R/W	R/W	R/W	R/W

LEGEND: R/W = Read/Write; R = Read only; -n = value after reset

表 11. REG08 (ADC_EN)

Bit	Field	Type	Reset			Description
			REG_RST	Watchdog	EN	
7	VBUS_ADC_EN	R/W	Y	N	Y	Enable/ disable conversion of VBUS voltage 0 – disable conversion 1 – enabled conversion (default)
6	IBUS_ADC_EN	R/W	Y	N	Y	Enable/ disable conversion of IBUS current 0 – disable conversion 1 – enabled conversion (default)
5	VOUT_ADC_EN	R/W	Y	N	Y	Enable/ disable conversion of VOOUT voltage 0 – disable conversion 1 – enabled conversion (default)
4	VDROP_ADC_EN	R/W	Y	N	Y	Enable/ disable conversion of VDROP voltage 0 – disable conversion 1 – enabled conversion (default)
3	VBAT_ADC_EN	R/W	Y	N	Y	Enable/ disable conversion of VBAT voltage 0 – disable conversion 1 – enabled conversion (default)
2	IBAT_ADC_EN	R/W	Y	N	Y	Enable/ disable conversion of IBAT current 0 – disable conversion 1 – enabled conversion (default)
1	TS_BUS_ADC_EN	R/W	Y	N	Y	Enable/ disable conversion of TS_BUS voltage 0 – disable conversion 1 – enabled conversion (default)
0	TS_BAT_ADC_EN	R/W	Y	N	Y	Enable/ disable conversion of TS_BAT voltage 0 – disable conversion 1 – enabled conversion (default)

8.5.11 REG09 (PROTECTION)

图 30. REG09 (PROTECTION)

7	6	5	4	3	2	1	0
1	0	1	0	0	0	0	0
R/W	R/W	R/W	R/W	R	R	R/W	R/W

LEGEND: R/W = Read/Write; R = Read only; -n = value after reset

表 12. REG09

Bit	Field	Type	Reset			Description
			REG_RST	Watchdog	EN	
7	IBUS_OCP[3]	R/W	Y	N	Y	4 A VBUS input overcurrent threshold Offset: none Range: 0 A to 7.5 A Default: 5 A (1010)
6	IBUS_OCP[2]	R/W	Y	N	Y	
5	IBUS_OCP[1]	R/W	Y	N	Y	
4	IBUS_OCP[0]	R/W	Y	N	Y	
3	Reserved	R	Y	N	Y	Reserved bit. Always read 0.
2	Reserved	R	Y	N	Y	Reserved bit. Always read 0.
1	OCP_RES	R/W	Y	N	Y	Controls the response of the OCP event or IBUS 0 – BLANKING mode; the device will wait 128 μ s before the battery switch is disabled and latched off (default) 1 – HICCUP mode; battery switch is disabled instantaneously, and the device will attempt to turn on the battery switch every 100 ms, up to 7 times before latching off.
0	VBUS_OVP_DLY	R/W	Y	N	Y	Set VBUS fault deglitch time 0 – 8 μ s deglitch time (default) 1 – 128 μ s deglitch time

8.5.12 REG0A (VBUS_OVP)

图 31. REG0A (VBUS_OVP)

7	6	5	4	3	2	1	0
0	0	1	0	1	0	1	1
R	R/W	R/W	R/W	R/W	R/W	R/W	R/W

LEGEND: R/W = Read/Write; R = Read only; -n = value after reset

表 13. REG0A (VBUS_OVP)

Bit	Field	Type	Reset			Description
			REG_RST	Watchdog	EN	
7	Reserved	R	Y	N	Y	Reserved bit. Always read 0.
6	VBUS_OVP[6]	R/W	Y	N	Y	1920 mV VBUS over voltage threshold Offset: 4.2 V Range: 4.2 V to 6.51 V Default: 5.49 V (00101011)
5	VBUS_OVP[5]	R/W	Y	N	Y	
4	VBUS_OVP[4]	R/W	Y	N	Y	
3	VBUS_OVP[3]	R/W	Y	N	Y	
2	VBUS_OVP[2]	R/W	Y	N	Y	
1	VBUS_OVP[1]	R/W	Y	N	Y	
0	VBUS_OVP[0]	R/W	Y	N	Y	

8.5.13 REG0B (VOUT_REG)
图 32. REG0B (VOUT_REG)

7	6	5	4	3	2	1	0
0	0	0	1	0	0	0	0
R	R/W	R/W	R/W	R/W	R/W	R/W	R/W

LEGEND: R/W = Read/Write; R = Read only; -n = value after reset

表 14. REG0B (VOUT_REG)

Bit	Field	Type	Reset			Description	
			REG_RST	Watchdog	EN		
7	Reserved	R	Y	N	Y	Reserved bit. Always read 0.	
6	VOUT_OVP[5]	R/W	Y	N	Y	VOUT regulation threshold Offset: 4.2 V Range: 4.2 V to 4.975 V Default: 4.4 V (00010000)	
5	VOUT_OVP[4]	R/W	Y	N	Y		800 mV
4	VBUS_OVP[3]	R/W	Y	N	Y		400 mV
3	VBUS_OVP[2]	R/W	Y	N	Y		200 mV
2	VBUS_OVP[1]	R/W	Y	N	Y		100 mV
1	VBUS_OVP[0]	R/W	Y	N	Y	50 mV	
0	Reserved	R/W	Y	N	Y	25 mV	
0	Reserved	R/W	Y	N	Y	Reserved bit. Always read 0.	

8.5.14 REG0C (VDROP_OVP)
图 33. REG0C (VDROP_OVP)

7	6	5	4	3	2	1	0
0	0	1	1	1	1	0	0
R/W	R/W	R/W	R/W	R/W	R/W	R/W	R

LEGEND: R/W = Read/Write; R = Read only; -n = value after reset

表 15. REG0C (VDROP_OVP)

Bit	Field	Type	Reset			Description
			REG_RST	Watchdog	EN	
7	VDROP_OVP[6]	R/W	Y	N	Y	640 mV
6	VDROP_OVP[5]	R/W	Y	N	Y	320 mV
5	VDROP_OVP[4]	R/W	Y	N	Y	160 mV
4	VDROP_OVP[3]	R/W	Y	N	Y	80 mV
3	VDROP_OVP[2]	R/W	Y	N	Y	40 mV
2	VDROP_OVP[1]	R/W	Y	N	Y	20 mV
1	VDROP_OVP[1]	R/W	Y	N	Y	10 mV
0	Reserved	R	Y	N	Y	Reserved bit. Always read 0.

8.5.15 REG0D (VDROP_ALM)
图 34. REG0D (VDROP_ALM)

7	6	5	4	3	2	1	0
0	0	0	1	0	1	0	0
R/W	R/W	R/W	R/W	R/W	R/W	R/W	R

LEGEND: R/W = Read/Write; R = Read only; -n = value after reset

表 16. REG0D (VDROP_ALM)

Bit	Field	Type	Reset			Description
			REG_RST	Watchdog	EN	
7	VDROP_ALM[6]	R/W	Y	N	Y	640 mV
6	VDROP_ALM[5]	R/W	Y	N	Y	320 mV
5	VDROP_ALM[4]	R/W	Y	N	Y	160 mV
4	VDROP_ALM[3]	R/W	Y	N	Y	80 mV
3	VDROP_ALM[2]	R/W	Y	N	Y	40 mV
2	VDROP_ALM[1]	R/W	Y	N	Y	20 mV
1	VDROP_ALM[1]	R/W	Y	N	Y	10 mV
0	Reserved	R	Y	N	Y	Reserved bit. Always read 0.

8.5.16 REG0E (VBAT_REG)

图 35. REG0E (VBAT_REG)

7	6	5	4	3	2	1	0
0	0	0	0	1	0	0	0
R	R/W	R/W	R/W	R/W	R/W	R/W	R/W

LEGEND: R/W = Read/Write; R = Read only; -n = value after reset

表 17. REG0E (VBAT_REG)

Bit	Field	Type	Reset			Description	
			REG_RST	Watchdog	EN		
7	Reserved	R	Y	N	Y	Reserved bit. Always read 0.	
6	VBAT_REG[6]	R/W	Y	N	Y	800 mV Battery voltage regulation threshold Offset: 4.2 V Range: 4.2 V to 4.975 V Default: 4.3 V (00001000)	
5	VBAT_REG[5]	R/W	Y	N	Y		400 mV
4	VBAT_REG[4]	R/W	Y	N	Y		200 mV
3	VBAT_REG[3]	R/W	Y	N	Y		100 mV
2	VBAT_REG[2]	R/W	Y	N	Y		50 mV
1	VBAT_REG[1]	R/W	Y	N	Y		25 mV
0	VBAT_REG[0]	R/W	Y	N	Y		12.5 mV

8.5.17 REG0F (IBAT_REG)

图 36. REG0F (IBAT_REG)

7	6	5	4	3	2	1	0
0	0	1	0	1	0	0	0
R	R/W	R/W	R/W	R/W	R/W	R/W	R/W

LEGEND: R/W = Read/Write; R = Read only; -n = value after reset

表 18. REG0F (IBAT_REG)

Bit	Field	Type	Reset			Description	
			REG_RST	Watchdog	EN		
7	Reserved	R	Y	N	Y	Reserved bit. Always read 0.	
6	IBAT_REG[6]	R/W	Y	N	Y	3200 mA Battery current regulation threshold Offset: 0 A Range: 0 A to 6.35 A Default: 2 A (00101000)	
5	IBAT_REG[5]	R/W	Y	N	Y		1600 mA
4	IBAT_REG[4]	R/W	Y	N	Y		800 mA
3	IBAT_REG[3]	R/W	Y	N	Y		400 mA
2	IBAT_REG[2]	R/W	Y	N	Y		200 mA
1	IBAT_REG[1]	R/W	Y	N	Y		100 mA
0	IBAT_REG[0]	R/W	Y	N	Y		50 mA

8.5.18 REG10 (IBUS_REG)

图 37. REG10 (IBUS_REG)

7	6	5	4	3	2	1	0
1	1	1	0	0	1	0	0
R	R/W	R/W	R/W	R/W	R/W	R/W	R

LEGEND: R/W = Read/Write; R = Read only; -n = value after reset

表 19. REG10 (IBUS_REG)

Bit	Field	Type	Reset			Description	
			REG_RST	Watchdog	EN		
7	Reserved	R	Y	N	Y	Reserved bit. Always read 0.	
6	IBUS_REG[5]	R/W	Y	N	Y	3200 mA Battery current regulation threshold Offset: 0 A Range: 0 A to 6.3 A Default: 5 A (01100100)	
5	IBUS_REG[4]	R/W	Y	N	Y		1600 mA
4	IBUS_REG[3]	R/W	Y	N	Y		800 mA
3	IBUS_REG[2]	R/W	Y	N	Y		400 mA
2	IBUS_REG[1]	R/W	Y	N	Y		200 mA
1	IBUS_REG[0]	R/W	Y	N	Y	100 mA	
0	Reserved	R	Y	N	Y	Reserved bit. Always read 0.	

8.5.19 REG11 (TS_BUS_FLT)

图 38. REG11 (TS_BUS_FLT)

7	6	5	4	3	2	1	0
0	0	0	1	1	0	0	0
R	R/W	R/W	R/W	R/W	R/W	R/W	R/W

LEGEND: R/W = Read/Write; R = Read only; -n = value after reset

表 20. REG11 (TS_BUS_FLT)

Bit	Field	Type	Reset			Description	
			REG_RST	Watchdog	EN		
7	Reserved	R	Y	N	Y	Reserved bit. Always read 0.	
6	TS_BUS_FLT[6]	R/W	Y	N	Y	1600 mA TS_BUS voltage threshold Offset: 0 V Range: 0 V to 1.4 V Default: 0.6 V (00011000)	
5	TS_BUS_FLT[5]	R/W	Y	N	Y		800 mA
4	TS_BUS_FLT[4]	R/W	Y	N	Y		400 mA
3	TS_BUS_FLT[3]	R/W	Y	N	Y		200 mA
2	TS_BUS_FLT[2]	R/W	Y	N	Y		100 mA
1	TS_BUS_FLT[1]	R/W	Y	N	Y		50 mA
0	TS_BUS_FLT[0]	R/W	Y	N	Y		25 mA

8.5.20 REG12 (TS_BAT_FLT)

图 39. REG12 (TS_BAT_FLT)

7	6	5	4	3	2	1	0
0	0	0	1	1	1	0	0
R	R/W	R/W	R/W	R/W	R/W	R/W	R/W

LEGEND: R/W = Read/Write; R = Read only; -n = value after reset

表 21. REG12 (TS_BAT_FLT)

Bit	Field	Type	Reset			Description
			REG_RST	Watchdog	EN	
7	Reserved	R	Y	N	Y	Reserved bit. Always read 0.
6	TS_BAT_FLT[6]	R/W	Y	N	Y	1600 mA
5	TS_BAT_FLT[5]	R/W	Y	N	Y	800 mA
4	TS_BAT_FLT[4]	R/W	Y	N	Y	400 mA
3	TS_BAT_FLT[3]	R/W	Y	N	Y	200 mA
2	TS_BAT_FLT[2]	R/W	Y	N	Y	100 mA
1	TS_BAT_FLT[1]	R/W	Y	N	Y	50 mA
0	TS_BAT_FLT[0]	R/W	Y	N	Y	25 mA

TS_BAT voltage threshold
Offset: 0 V
Range: 0 V to 1.4 V
Default: 0.7 V (00011100)

8.5.21 REG 13 and REG 14 (VBUS_ADC)

图 40. REG 13 and REG 14 (VBUS_ADC)

REG13								REG14							
7	6	5	4	3	2	1	0	7	6	5	4	3	2	1	0
0	0	0	0	0	0	0	0	0	0	0	0	0	0	0	0
R	R	R	R	R	R	R	R	R	R	R	R	R	R	R	R

LEGEND: R/W = Read/Write; R = Read only; -n = value after reset

表 22. REG 13 and REG 14 (VBUS_ADC)

Register	Bit	Field	Type	Reset			Description
				REG_RST	Watchdog	EN	
REG13	7	VBUS_POL	R	Y	N	Y	Indicates polarity of VBUS voltage. Always positive. 0 - positive voltage 1 - negative voltage
	6	VBUS_ADC[14]	R	Y	N	Y	16384 mV
	5	VBUS_ADC[13]	R	Y	N	Y	8192 mV
	4	VBUS_ADC[12]	R	Y	N	Y	4096 mV
	3	VBUS_ADC[11]	R	Y	N	Y	2048 mV
	2	VBUS_ADC[10]	R	Y	N	Y	1024 mV
	1	VBUS_ADC[9]	R	Y	N	Y	512 mV
	0	VBUS_ADC[8]	R	Y	N	Y	256 mV
REG14	7	VBUS_ADC[7]	R	Y	N	Y	128 mV
	6	VBUS_ADC[6]	R	Y	N	Y	64 mV
	5	VBUS_ADC[5]	R	Y	N	Y	32 mV
	4	VBUS_ADC[4]	R	Y	N	Y	16 mV
	3	VBUS_ADC[3]	R	Y	N	Y	8 mV
	2	VBUS_ADC[2]	R	Y	N	Y	4 mV
	1	VBUS_ADC[1]	R	Y	N	Y	2 mV
	0	VBUS_ADC[0]	R	Y	N	Y	1 mV

Voltage representation of ADC conversion of VBUS voltage.
Range: 0 V, and 2.048 V to 6.140 V
Default: 0 V (0000000000000000)
If VBUS < 0.3 V, VBUS_ADC = 0.3 V

8.5.22 REG15 and REG16 (IBUS_ADC)
图 41. REG15 and REG16 (IBUS_ADC)

REG15								REG16							
7	6	5	4	3	2	1	0	7	6	5	4	3	2	1	0
0	0	0	0	0	0	0	0	0	0	0	0	0	0	0	0
R	R	R	R	R	R	R	R	R	R	R	R	R	R	R	R

LEGEND: R/W = Read/Write; R = Read only; -n = value after reset

表 23. REG15 and REG16 (IBUS_ADC)

Register	Bit	Field	Type	Reset			Description
				REG_RST	Watchdog	EN	
REG15	7	IBUS_POL	R	Y	N	Y	Indicates polarity of IBUS current. Always positive. 0 - positive current 1 - negative current
	6	IBUS_ADC[14]	R	Y	N	Y	16384 mA
	5	IBUS_ADC[13]	R	Y	N	Y	8192 mA
	4	IBUS_ADC[12]	R	Y	N	Y	4096 mA
	3	IBUS_ADC[11]	R	Y	N	Y	2048 mA
	2	IBUS_ADC[10]	R	Y	N	Y	1024 mA
	1	IBUS_ADC[9]	R	Y	N	Y	512 mA
REG16	0	IBUS_ADC[8]	R	Y	N	Y	256 mA
	7	IBUS_ADC[7]	R	Y	N	Y	128 mA
	6	IBUS_ADC[6]	R	Y	N	Y	64 mA
	5	IBUS_ADC[5]	R	Y	N	Y	32 mA
	4	IBUS_ADC[4]	R	Y	N	Y	16 mA
	3	IBUS_ADC[3]	R	Y	N	Y	8 mA
	2	IBUS_ADC[2]	R	Y	N	Y	4 mA
	1	IBUS_ADC[1]	R	Y	N	Y	2 mA
0	IBUS_ADC[0]	R	Y	N	Y	1 mA	

8.5.23 REG17 and REG18 (VOUT_ADC)
图 42. REG17 and REG18 (VOUT_ADC)

REG17								REG18							
7	6	5	4	3	2	1	0	7	6	5	4	3	2	1	0
0	0	0	0	0	0	0	0	0	0	0	0	0	0	0	0
R	R	R	R	R	R	R	R	R	R	R	R	R	R	R	R

LEGEND: R/W = Read/Write; R = Read only; -n = value after reset

表 24. REG17 and REG18 (VOUT_ADC)

Register	Bit	Field	Type	Reset			Description
				REG_RST	Watchdog	EN	
REG17	7	VOUT_POL	R	Y	N	Y	Indicates polarity of VDROPP voltage. Always positive. 0 - positive voltage 1 - negative voltage
	6	VOUT_ADC[14]	R	Y	N	Y	16384 mV
	5	VOUT_ADC[13]	R	Y	N	Y	8192 mV
	4	VOUT_ADC[12]	R	Y	N	Y	4096 mV
	3	VOUT_ADC[11]	R	Y	N	Y	2048 mV
	2	VOUT_ADC[10]	R	Y	N	Y	1024 mV
	1	VOUT_ADC[9]	R	Y	N	Y	512 mV
	0	VOUT_ADC[8]	R	Y	N	Y	256 mV
REG18	7	VOUT_ADC[7]	R	Y	N	Y	128 mV
	6	VOUT_ADC[6]	R	Y	N	Y	64 mV
	5	VOUT_ADC[5]	R	Y	N	Y	32 mV
	4	VOUT_ADC[4]	R	Y	N	Y	16 mV
	3	VOUT_ADC[3]	R	Y	N	Y	8 mV
	2	VOUT_ADC[2]	R	Y	N	Y	4 mV
	1	VOUT_ADC[1]	R	Y	N	Y	2 mV
	0	VOUT_ADC[0]	R	Y	N	Y	1 mV

8.5.24 REG19 and REG1A (VDROP_ADC)
图 43. REG19 and REG1A (VDROP_ADC)

REG19								REG1A							
7	6	5	4	3	2	1	0	7	6	5	4	3	2	1	0
0	0	0	0	0	0	0	0	0	0	0	0	0	0	0	0
R	R	R	R	R	R	R	R	R	R	R	R	R	R	R	R

LEGEND: R/W = Read/Write; R = Read only; -n = value after reset

表 25. REG19 and REG1A (VDROP_ADC)

Register	Bit	Field	Type	Reset			Description
				REG_RST	Watchdog	EN	
REG19	7	VDROP_POL	R	Y	N	Y	Indicates polarity of VDROP voltage. Always positive. 0 - positive voltage 1 - negative voltage
	6	VDROP_ADC[14]	R	Y	N	Y	16384 mV
	5	VDROP_ADC[13]	R	Y	N	Y	8192 mV
	4	VDROP_ADC[12]	R	Y	N	Y	4096 mV
	3	VDROP_ADC[11]	R	Y	N	Y	2048 mV
	2	VDROP_ADC[10]	R	Y	N	Y	1024 mV
	1	VDROP_ADC[9]	R	Y	N	Y	512 mV
REG1A	0	VDROP_ADC[8]	R	Y	N	Y	256 mV
	7	VDROP_ADC[7]	R	Y	N	Y	128 mV
	6	VDROP_ADC[6]	R	Y	N	Y	64 mV
	5	VDROP_ADC[5]	R	Y	N	Y	32 mV
	4	VDROP_ADC[4]	R	Y	N	Y	16 mV
	3	VDROP_ADC[3]	R	Y	N	Y	8 mV
	2	VDROP_ADC[2]	R	Y	N	Y	4 mV
	1	VDROP_ADC[1]	R	Y	N	Y	2 mV
0	VDROP_ADC[0]	R	Y	N	Y	1 mV	

8.5.25 REG1B and REG1C (VBAT_ADC)
图 44. REG1B and REG1C (VBAT_ADC)

REG1B								REG1C							
7	6	5	4	3	2	1	0	7	6	5	4	3	2	1	0
0	0	0	0	0	0	0	0	0	0	0	0	0	0	0	0
R	R	R	R	R	R	R	R	R	R	R	R	R	R	R	R

LEGEND: R/W = Read/Write; R = Read only; -n = value after reset

表 26. REG1B and REG1C (VBAT_ADC)

Register	Bit	Field	Type	Reset			Description
				REG_RST	Watchdog	EN	
REG1B	7	VBAT_POL	R	Y	N	Y	Indicates polarity of VBUS voltage. Always positive. 0 - positive voltage 1 - negative voltage
	6	VBAT_ADC[14]	R	Y	N	Y	16384 mV
	5	VBAT_ADC[13]	R	Y	N	Y	8192 mV
	4	VBAT_ADC[12]	R	Y	N	Y	4096 mV
	3	VBAT_ADC[11]	R	Y	N	Y	2048 mV
	2	VBAT_ADC[10]	R	Y	N	Y	1024 mV
	1	VBAT_ADC[9]	R	Y	N	Y	512 mV
	0	VBAT_ADC[8]	R	Y	N	Y	256 mV
REG1C	7	VBAT_ADC[7]	R	Y	N	Y	128 mV
	6	VBAT_ADC[6]	R	Y	N	Y	64 mV
	5	VBAT_ADC[5]	R	Y	N	Y	32 mV
	4	VBAT_ADC[4]	R	Y	N	Y	16 mV
	3	VBAT_ADC[3]	R	Y	N	Y	8 mV
	2	VBAT_ADC[2]	R	Y	N	Y	4 mV
	1	VBAT_ADC[1]	R	Y	N	Y	2 mV
	0	VBAT_ADC[0]	R	Y	N	Y	1 mV

8.5.26 REG1D and REG1E (IBAT_ADC)
图 45. REG1D and REG1E (IBAT_ADC)

REG1D								REG1E							
7	6	5	4	3	2	1	0	7	6	5	4	3	2	1	0
0	0	0	0	0	0	0	0	0	0	0	0	0	0	0	0
R	R	R	R	R	R	R	R	R	R	R	R	R	R	R	R

LEGEND: R/W = Read/Write; R = Read only; -n = value after reset

表 27. REG1D and REG1E (IBAT_ADC)

Register	Bit	Field	Type	Reset			Description
				REG_RST	Watchdog	EN	
REG1D	7	IBAT_POL	R	Y	N	Y	Indicates polarity of battery current. 0 - positive voltage (default) 1 - negative voltage
	6	IBAT_ADC[14]	R	Y	N	Y	16384 mV
	5	IBAT_ADC[13]	R	Y	N	Y	8192 mV
	4	IBAT_ADC[12]	R	Y	N	Y	4096 mV
	3	IBAT_ADC[11]	R	Y	N	Y	2048 mV
	2	IBAT_ADC[10]	R	Y	N	Y	1024 mV
	1	IBAT_ADC[9]	R	Y	N	Y	512 mV
	0	IBAT_ADC[8]	R	Y	N	Y	256 mV
REG1E	7	IBAT_ADC[7]	R	Y	N	Y	128 mV
	6	IBAT_ADC[6]	R	Y	N	Y	64 mV
	5	IBAT_ADC[5]	R	Y	N	Y	32 mV
	4	IBAT_ADC[4]	R	Y	N	Y	16 mV
	3	IBAT_ADC[3]	R	Y	N	Y	8 mV
	2	IBAT_ADC[2]	R	Y	N	Y	4 mV
	1	IBAT_ADC[1]	R	Y	N	Y	2 mV
	0	IBAT_ADC[0]	R	Y	N	Y	1 mV

8.5.27 REG1F and REG20 (TS_BUS_ADC)
图 46. REG1F and REG20 (TS_BUS_ADC)

REG1F								REG20							
7	6	5	4	3	2	1	0	7	6	5	4	3	2	1	0
0	0	0	0	0	0	0	0	0	0	0	0	0	0	0	0
R	R	R	R	R	R	R	R	R	R	R	R	R	R	R	R

LEGEND: R/W = Read/Write; R = Read only; -n = value after reset

表 28. REG1F and REG20 (TS_BUS_ADC)

Register	Bit	Field	Type	Reset			Description
				REG_RST	Watchdog	EN	
REG1F	7	TS_BUS_POL	R	Y	N	Y	Indicates polarity of TS_BUS voltage. Always positive. 0 - positive voltage 1 - negative voltage
	6	TS_BUS_ADC [14]	R	Y	N	Y	16384 mV
	5	TS_BUS_ADC [13]	R	Y	N	Y	8192 mV
	4	TS_BUS_ADC [12]	R	Y	N	Y	4096 mV
	3	TS_BUS_ADC [11]	R	Y	N	Y	2048 mV
	2	TS_BUS_ADC [10]	R	Y	N	Y	1024 mV
	1	TS_BUS_ADC [9]	R	Y	N	Y	512 mV
REG20	0	TS_BUS_ADC [8]	R	Y	N	Y	256 mV
	7	TS_BUS_ADC [7]	R	Y	N	Y	128 mV
	6	TS_BUS_ADC [6]	R	Y	N	Y	64 mV
	5	TS_BUS_ADC [5]	R	Y	N	Y	32 mV
	4	TS_BUS_ADC [4]	R	Y	N	Y	16 mV
	3	TS_BUS_ADC [3]	R	Y	N	Y	8 mV
	2	TS_BUS_ADC [2]	R	Y	N	Y	4 mV
	1	TS_BUS_ADC [1]	R	Y	N	Y	2 mV
0	TS_BUS_ADC [0]	R	Y	N	Y	1 mV	

8.5.28 REG21 and REG22 (TS_BAT_ADC)

图 47. REG21 and REG22 (TS_BAT_ADC)

REG21								REG22							
7	6	5	4	3	2	1	0	7	6	5	4	3	2	1	0
0	0	0	0	0	0	0	0	0	0	0	0	0	0	0	0
R	R	R	R	R	R	R	R	R	R	R	R	R	R	R	R

LEGEND: R/W = Read/Write; R = Read only; -n = value after reset

表 29. REG21 and REG22 (TS_BAT_ADC)

Register	Bit	Field	Type	Reset			Description
				REG_RST	Watchdog	EN	
REG21	7	TS_BAT_POL	R	Y	N	Y	Indicates polarity of TS_BAT voltage. Always positive. 0 - positive voltage 1 - negative voltage
	6	TS_BAT_ADC [14]	R	Y	N	Y	16384 mV
	5	TS_BAT_ADC [13]	R	Y	N	Y	8192 mV
	4	TS_BAT_ADC [12]	R	Y	N	Y	4096 mV
	3	TS_BAT_ADC [11]	R	Y	N	Y	2048 mV
	2	TS_BAT_ADC [10]	R	Y	N	Y	1024 mV
	1	TS_BAT_ADC [9]	R	Y	N	Y	512 mV
REG22	0	TS_BAT_ADC [8]	R	Y	N	Y	256 mV
	7	TS_BAT_ADC [7]	R	Y	N	Y	128 mV
	6	TS_BAT_ADC [6]	R	Y	N	Y	64 mV
	5	TS_BAT_ADC [5]	R	Y	N	Y	32 mV
	4	TS_BAT_ADC [4]	R	Y	N	Y	16 mV
	3	TS_BAT_ADC [3]	R	Y	N	Y	8 mV
	2	TS_BAT_ADC [2]	R	Y	N	Y	4 mV
	1	TS_BAT_ADC [1]	R	Y	N	Y	2 mV
0	TS_BAT_ADC [0]	R	Y	N	Y	1 mV	

8.5.29 REG 23 (TDIE_ADC)

图 48. REG23 (TDIE_ADC)

7	6	5	4	3	2	1	0
0	0	0	0	0	0	0	0
R	R	R	R	R	R	R	R

LEGEND: R/W = Read/Write; R = Read only; -n = value after reset

表 30. REG23 (TDIE_ADC)

Bit	Field	Type	Reset			Description
			REG_RST	Watchdog	EN	
7	DIE_TEMP_ADC [7]	R	Y	N	Y	128°C
6	DIE_TEMP_ADC [6]	R	Y	N	Y	64°C
5	DIE_TEMP_ADC [5]	R	Y	N	Y	32°C
4	DIE_TEMP_ADC [4]	R	Y	N	Y	16°C
3	DIE_TEMP_ADC [3]	R	Y	N	Y	8°C
2	DIE_TEMP_ADC [2]	R	Y	N	Y	4°C
1	DIE_TEMP_ADC [1]	R	Y	N	Y	2°C
0	DIE_TEMP_ADC [0]	R	Y	N	Y	1°C

8.5.30 REG 24 (EVENT_2_EN)
图 49. REG24 (EVENT_2_EN)

7	6	5	4	3	2	1	0
0	0	0	0	1	0	0	0
R/W	R	R	R	R/W	R/W	R/W	R/W

LEGEND: R/W = Read/Write; R = Read only; -n = value after reset

表 31. REG24 (EVENT_2_EN) (0x24 Register)

Bit	Field	Type	Reset			Description
			REG_RST	Watchdog	EN	
7	VDROP_AMP_DIS	R/W	Y	N	Y	Turn on/ off VDROP AMP 0 – Turn on VDROP AMP (default) 1 – Turn off VDROP AMP
6	Reserved	R	N/A	N/A	N/A	Reserved bit. Always reads 0.
5	Reserved	R	N/A	N/A	N/A	Reserved bit. Always reads 0.
4	Reserved	R	N/A	N/A	N/A	Reserved bit. Always reads 0.
3	IBUS_OCP_EN	R/W	Y	N	Y	Enable/ disable IBUS over current protection 0 – disable IBUS OCP 1 – enabled IBUS OCP (default)
2	VBAT_OVP_EN	R/W	Y	N	Y	Enable/ disable VBAT over voltage protection 0 – disable VBAT OVP (default) 1 – enabled VBAT OVP
1	IBAT_OCP_EN	R/W	Y	N	Y	Enable/ disable IBAT over current protection 0 – disable IBAT OCP (default) 1 – enabled IBAT OCP
0	VOUT_OVP_EN	R/W	Y	N	Y	Enable/ disable VOUT over voltage protection 0 – disable VOUT OVP protection (default) 1 – enabled VOUT_OVP

8.5.31 REG 25 (EVENT_3_MASK)
图 50. REG25 (EVENT_3_MASK)

7	6	5	4	3	2	1	0
0	0	0	0	0	0	0	0
R	R	R	R	R	R/W	R/W	R/W

LEGEND: R/W = Read/Write; R = Read only; -n = value after reset

表 32. REG26 (EVENT_3_MASK) (0x026 Register)

Bit	Field	Type	Reset			Description
			REG_RST	Watchdog	EN	
7	Reserved	R	N/A	N/A	N/A	Reserved bit. Always reads 0.
6	Reserved	R	N/A	N/A	N/A	Reserved bit. Always reads 0.
5	Reserved	R	N/A	N/A	N/A	Reserved bit. Always reads 0.
4	Reserved	R	N/A	N/A	N/A	Reserved bit. Always reads 0.
3	Reserved	R	N/A	N/A	N/A	Reserved bit. Always reads 0.
2	VBAT_OVP_MASK	R/W	Y	N	Y	VBAT over voltage fault mask. 0 – no mask. $\overline{\text{INT}}$ will assert low when VBAT_OVP bit is set (default) 1 – VBAT_OVP is masked. $\overline{\text{INT}}$ will not assert low when VBAT_OVP bit is set.
1	IBAT_OCP_MASK	R/W	Y	N	Y	IBAT over current fault mask. 0 – no mask. $\overline{\text{INT}}$ will assert low when IBAT_OCP bit is set (default) 1 – IBAT_OCP is masked. $\overline{\text{INT}}$ will not assert low when IBAT_OCP bit is set.
0	VOUT_OVP_MASK	R/W	Y	N	Y	VOUT over voltage fault mask. 0 – no mask. $\overline{\text{INT}}$ will assert low when VOUT_OVP bit is set (default) 1 – VOUT_OVP is masked. $\overline{\text{INT}}$ will not assert low when VOUT_OVP bit is set.

8.5.32 REG 26 (EVENT_3)
图 51. REG26 (EVENT_3)

7	6	5	4	3	2	1	0
0	0	0	0	0	0	0	0
R	R	R	R	R	R	R	R

LEGEND: R/W = Read/Write; R = Read only; -n = value after reset

表 33. REG26 (EVENT_3) (0x26 Register)

Bit	Field	Type	Reset			Description
			REG_RST	Watchdog	EN	
7	SCP_FLT	R	Y	N	Y	Indicates if high current from VBUS to VOUT has hit I_{SCP} threshold. Battery switch is disabled 0 – no fault (default) 1 – short circuit fault
6	Reserved	R	N/A	N/A	N/A	Reserved bit. Always reads 0.
5	Reserved	R	N/A	N/A	N/A	Reserved bit. Always reads 0.
4	Reserved	R	N/A	N/A	N/A	Reserved bit. Always reads 0.
3	Reserved	R	N/A	N/A	N/A	Reserved bit. Always reads 0.
2	VBAT_OVP_FLT	R	Y	N	Y	Indicates if VBAT_OVP threshold is reached. Battery switch is disabled 0 – no fault (default) 1 – VBAT_OVP fault
1	IBAT_OCP_FLT	R	Y	N	Y	Indicates if IBAT_OCP threshold is reached. Battery switch is disabled 0 – no fault (default) 1 – IBAT_OCP fault
0	VOUT_OVP_FLT	R	Y	N	Y	Indicates if VOUT_OVP threshold is reached. Battery switch is disabled 0 – no fault (default) 1 – VOUT_OVP fault

8.5.33 REG 29 (CONTROL_2)
图 52. REG29 (CONTROL_2)

7	6	5	4	3	2	1	0
0	0	0	0	0	0	0	0
R	R	R	R	R	R	R	R/W

LEGEND: R/W = Read/Write; R = Read only; -n = value after reset

表 34. REG29 (RSENSE) (0x29 Register)

Bit	Field	Type	Reset			Description
			REG_RST	Watchdog	EN	
7	Reserved	R	N/A	N/A	N/A	Reserved bit. Always reads 0.
6	Reserved	R	N/A	N/A	N/A	Reserved bit. Always reads 0.
5	Reserved	R	N/A	N/A	N/A	Reserved bit. Always reads 0.
4	Reserved	R	N/A	N/A	N/A	Reserved bit. Always reads 0.
3	Reserved	R	N/A	N/A	N/A	Reserved bit. Always reads 0.
2	Reserved	R	N/A	N/A	N/A	Reserved bit. Always reads 0.
1	Reserved	R	N/A	N/A	N/A	Reserved bit. Always reads 0.
0	R_PLACE	R/W	Y	N	Y	Select location of SRP/SRN sense resistor 0 – low-side placement (default) 1 – high-side placement

8.5.34 REG 40 (DIE_TEMP_FLT)
图 53. REG 40 (DIE_TEMP_FLT)

7	6	5	4	3	2	1	0
0	0	0	0	0	0	1	1
R	R	R	R	R	R	R/W	R/W

LEGEND: R/W = Read/Write; R = Read only; -n = value after reset

表 35. REG 40 (DIE_TEMP_FLT) (0x40 Register)

Bit	Field	Type	Reset			Description	
			REG_RST	Watchdog	EN		
7	Reserved	R	N/A	N/A	N/A	Reserved bit. Always reads 0.	
6	Reserved	R	N/A	N/A	N/A	Reserved bit. Always reads 0.	
5	Reserved	R	N/A	N/A	N/A	Reserved bit. Always reads 0.	
4	Reserved	R	N/A	N/A	N/A	Reserved bit. Always reads 0.	
3	Reserved	R	N/A	N/A	N/A	Reserved bit. Always reads 0.	
2	Reserved	R	N/A	N/A	N/A	Reserved bit. Always reads 0.	
1	DIE_TEMP_FLT [1]	R/W	Y	N	Y	30 C	TSHUT temperature threshold Offset: 105°C Range: 105°C to 150°C Default: 150°C (0b11)
0	DIE_TEMP_FLT [0]	R/W	Y	N	Y	15 C	

9 Application and Implementation

注

Information in the following applications sections is not part of the TI component specification, and TI does not warrant its accuracy or completeness. TI's customers are responsible for determining suitability of components for their purposes. Customers should validate and test their design implementation to confirm system functionality.

9.1 Application Information

A typical application consists of the device configured as an I²C controlled device and another switch mode charger for Li-Ion and Li-polymer batteries used in a wide range of smart phones and other portable devices. A host controls which charger is enabled during the charging process.

9.2 Typical Application



图 54. bq25871 Typical Application

Typical Application (接下页)

9.2.1 Design Requirements

表 36. Design Requirement

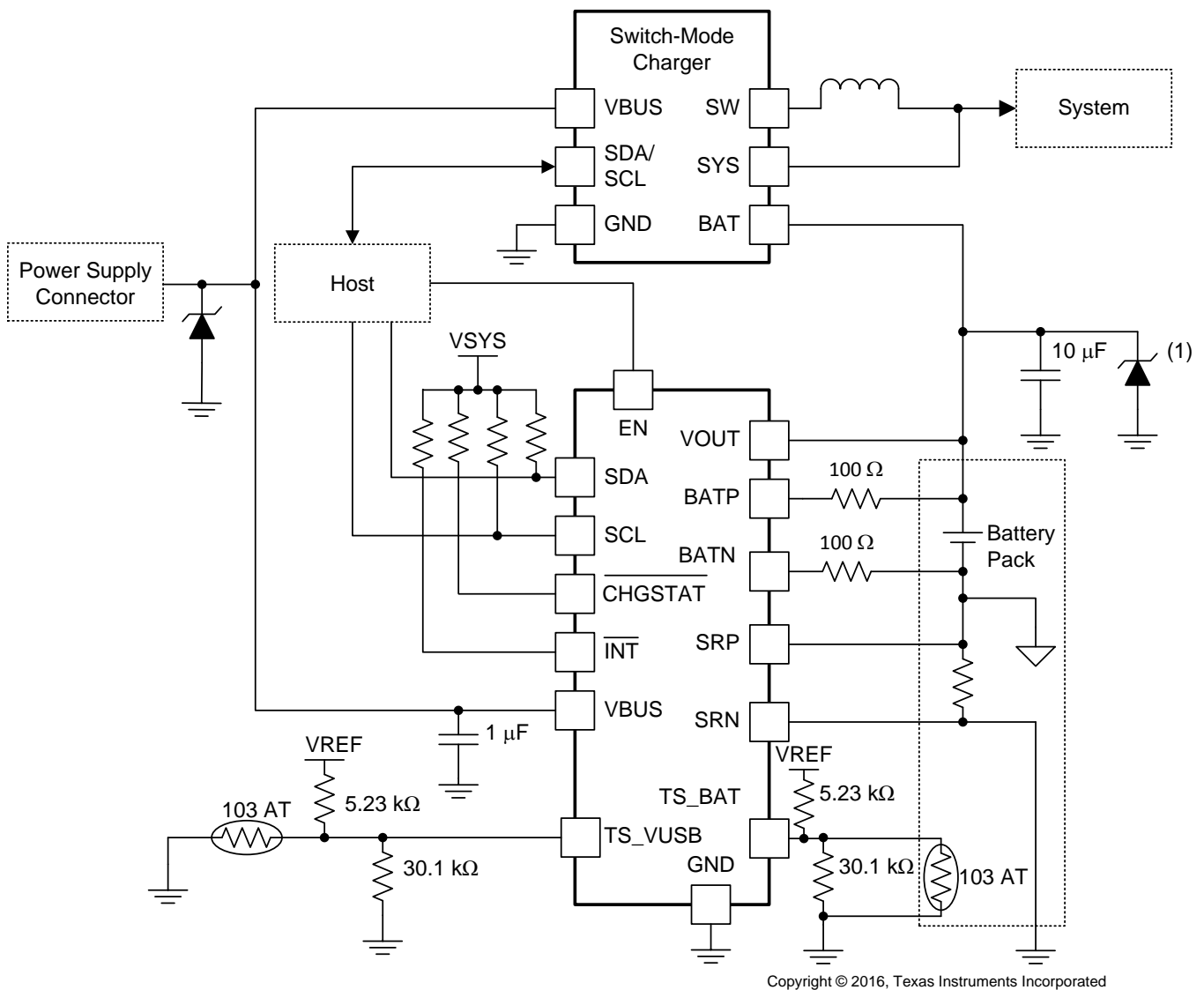
PARAMETER	VALUE
Input voltage range	3 V to 6 V
Input current limit	0.1 A to 7.5 A
Output voltage range	3 V to 4.975 V

9.2.2 Detailed Design Procedure

The bq25871 continuously monitors battery and adaptor connector temperature by measuring the voltage between TS_BAT pin and TS_BUS pins and ground, typically determined by a negative temperature coefficient thermistor and an external voltage divider. The device compares this voltage against its internal thresholds to determine if charging is allowed. To initiate a charging cycle, both battery and connector temperatures must be lower than the temperature threshold, else the device suspends charging and waits until both temperatures are below the threshold.

Assuming a 103 AT NTC thermistor is used on the battery pack, the values RT1 (connected between TS_X pin to VREF) and RT2 (connected between TS_X and ground) can be determined by using the following equations.

$$RT2 = \frac{V_{REF} \times RTH_{COLD} \times RTH_{HOT} \times \left(\frac{1}{V_{LTF}} - \frac{1}{V_{TCO}} \right)}{RTH_{HOT} \times \left(\frac{V_{REF}}{V_{TCO}} - 1 \right) - RTH_{COLD} \times \left(\frac{V_{REF}}{V_{LTF}} - 1 \right)}$$

$$RT1 = \frac{\frac{V_{REF}}{V_{LTF}} - 1}{\frac{1}{RT2} + \frac{1}{RTH_{COLD}}}$$

where

- RTH_{cold} and V_{LTF} are the resistance of NTC under the cold temperature and the corresponding TS_X pin voltage when charge is allowed, RTH_{hot} and V_{TCO} are the resistance of NTC under the hot temperature and the corresponding TS_X pin voltage when charge is allowed. (1)

9.2.3 Application Curves



图 55. Power Up with IBUS_REG = 1 A



图 56. IBAT Regulation During Load Step Down

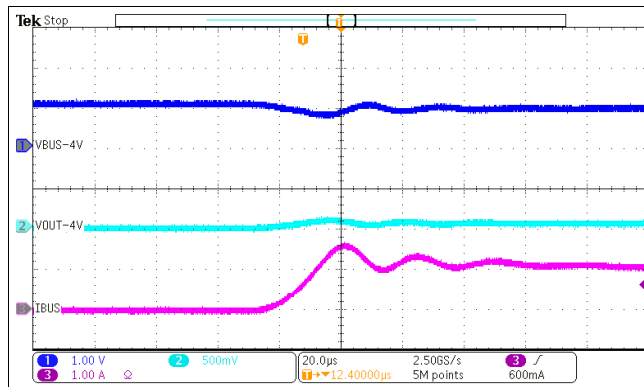

图 57. VBAT Regulation During Load Step Down

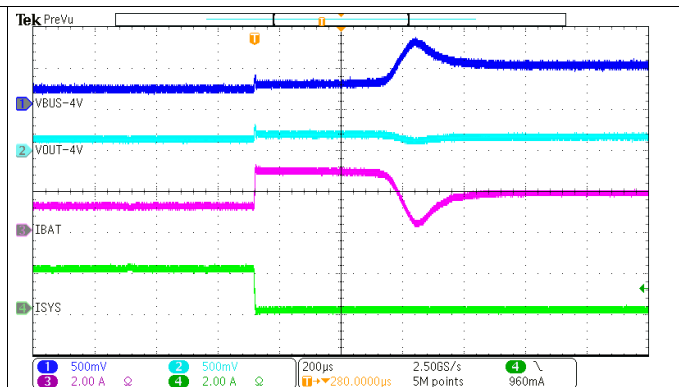

图 58. IBUS OCP During Load Transient

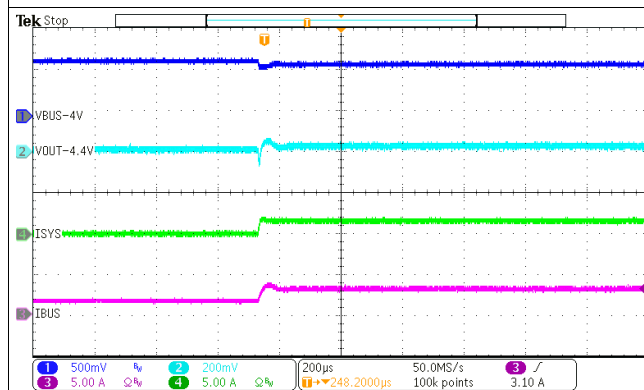

图 59. TS BUS OTP

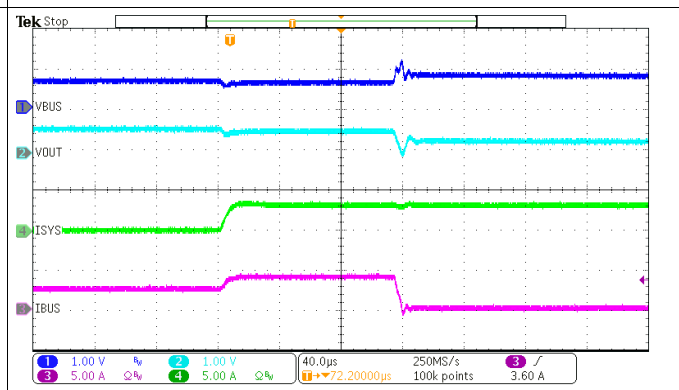

图 60. VBUS OVP with IBUS Regulation

10 Power Supply Recommendations

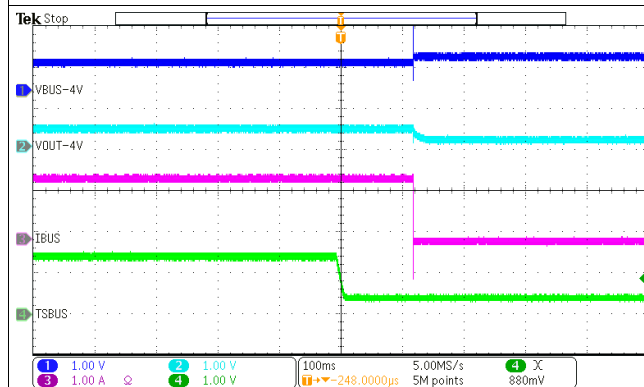
In order to provide an output voltage on SYS, the device requires a power supply between 3.9-V and 14-V input with at least 100-mA current rating connected to VBUS or a single-cell Li-Ion battery with voltage > VBATUVLO connected to BAT. The source current rating needs to be at least 7.5 A to meet the current capability of the device.

11 Layout

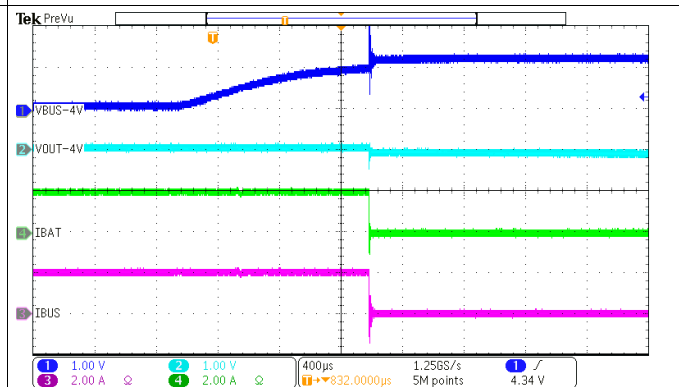
11.1 Layout Guidelines

bq25871 supports up to 7-A charge current. It is very critical to maximize Cu trace of VBUS and VOUT. Following PCB layout guideline is recommended:

- Use Cu trace of at least 110 mil (2.794 mm) wide for VBUS and VOUT respectively. This allows current flow evenly through all 7 WCSP solder balls.
- Cu trace of VBUS and VOUT should run at least 150 mil (3.81 mm) straight (perpendicular to WCSP ball array) before making turns.
- Use as large as possible Cu pour for VBUS and VOUT trace elsewhere.
- Use as large as possible Cu pour for PGND.
- Place decoupling capacitors of VBUS and VOUT as close as possible to the device.

11.2 Layout Example



图 61. bq25871 Layout Diagram (Top Layer)



图 62. bq25871 Layout Diagram (Mid Layer 2)

Layout Example (接下页)

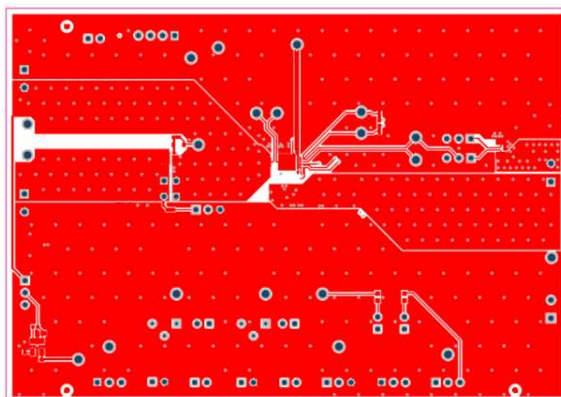

图 63. bq25871 Layout Diagram (Mid Layer 1)

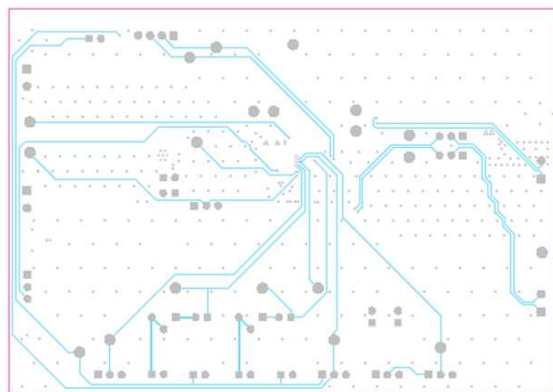

图 64. bq25871 Layout Diagram (Bottom 1)

12 器件和文档支持

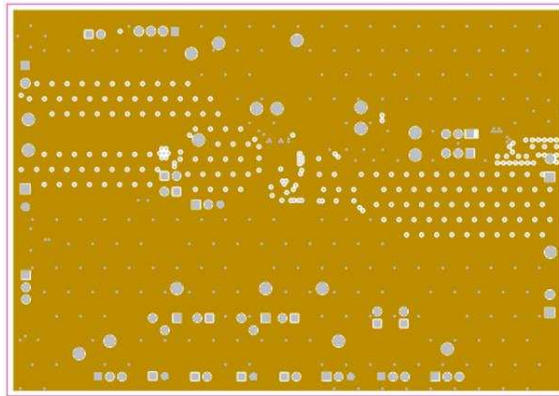
12.1 接收文档更新通知

如需接收文档更新通知，请访问 www.ti.com.cn 网站上的器件产品文件夹。点击右上角的提醒我 (Alert me) 注册后，即可每周定期收到已更改的产品信息。有关更改的详细信息，请查阅已修订文档中包含的修订历史记录。

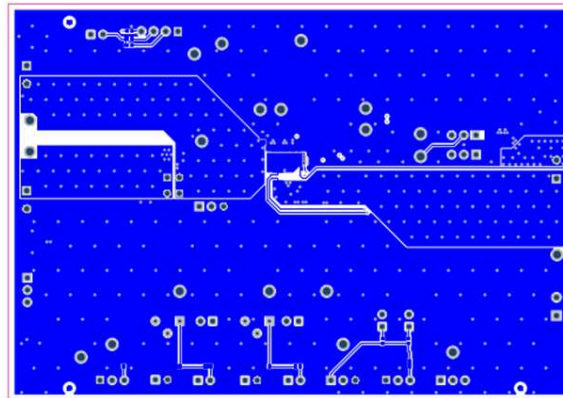
12.2 社区资源

The following links connect to TI community resources. Linked contents are provided "AS IS" by the respective contributors. They do not constitute TI specifications and do not necessarily reflect TI's views; see TI's [Terms of Use](#).

TI E2E™ Online Community *TI's Engineer-to-Engineer (E2E) Community*. Created to foster collaboration among engineers. At e2e.ti.com, you can ask questions, share knowledge, explore ideas and help solve problems with fellow engineers.

Design Support *TI's Design Support* Quickly find helpful E2E forums along with design support tools and contact information for technical support.

12.3 商标

E2E is a trademark of Texas Instruments.

I²C is a trademark of Philips Semiconductor.

All other trademarks are the property of their respective owners.

12.4 静电放电警告



ESD 可能会损坏该集成电路。德州仪器 (TI) 建议通过适当的预防措施处理所有集成电路。如果不遵守正确的处理措施和安装程序，可能会损坏集成电路。

ESD 的损坏小至导致微小的性能降级，大至整个器件故障。精密的集成电路可能更容易受到损坏，这是因为非常细微的参数更改都可能会导致器件与其发布的规格不相符。

12.5 Glossary

SLYZ022 — *TI Glossary*.

This glossary lists and explains terms, acronyms, and definitions.

13 机械、封装和可订购信息

以下页中包括机械、封装和可订购信息。这些信息是针对指定器件可提供的最新数据。这些数据会在无通知且不对本文档进行修订的情况下发生改变。欲获得该数据表的浏览器版本，请查阅左侧的导航栏。

重要声明

德州仪器(TI)及其下属子公司有权根据 JESD46 最新标准,对所提供的产品和服务进行更正、修改、增强、改进或其它更改,并有权根据 JESD48 最新标准中止提供任何产品和服务。客户在下订单前应获取最新的相关信息,并验证这些信息是否完整且是最新的。所有产品的销售都遵循在订单确认时所提供的TI 销售条款与条件。

TI 保证其所销售的组件的性能符合产品销售时 TI 半导体产品销售条件与条款的适用规范。仅在 TI 保证的范围内,且 TI 认为有必要时才会使用测试或其它质量控制技术。除非适用法律做出了硬性规定,否则没有必要对每种组件的所有参数进行测试。

TI 对应用帮助或客户产品设计不承担任何义务。客户应对其使用 TI 组件的产品和应用自行负责。为尽量减小与客户产品和应用相关的风险,客户应提供充分的设计与操作安全措施。

TI 不对任何 TI 专利权、版权、屏蔽作品权或其它与使用了 TI 组件或服务的组合设备、机器或流程相关的 TI 知识产权中授予的直接或隐含权限作出任何保证或解释。TI 所发布的与第三方产品或服务有关的信息,不能构成从 TI 获得使用这些产品或服务的许可、授权、或认可。使用此类信息可能需要获得第三方的专利权或其它知识产权方面的许可,或是 TI 的专利权或其它知识产权方面的许可。

对于 TI 的产品手册或数据表中 TI 信息的重要部分,仅在没有对内容进行任何篡改且带有相关授权、条件、限制和声明的情况下才允许进行复制。TI 对此类篡改过的文件不承担任何责任或义务。复制第三方的信息可能需要服从额外的限制条件。

在转售 TI 组件或服务时,如果对该组件或服务参数的陈述与 TI 标明的参数相比存在差异或虚假成分,则会失去相关 TI 组件或服务的所有明示或暗示授权,且这是不正当的、欺诈性商业行为。TI 对任何此类虚假陈述均不承担任何责任或义务。

客户认可并同意,尽管任何应用相关信息或支持仍可能由 TI 提供,但他们将独立负责满足与其产品及其在应用中使用的 TI 产品相关的所有法律、法规和安全相关要求。客户声明并同意,他们具备制定与实施安全措施所需的全部专业技术和知识,可预见故障的危险后果、监测故障及其后果、降低有可能造成人身伤害的故障的发生机率并采取适当的补救措施。客户将全额赔偿因在此类安全关键应用中使用任何 TI 组件而对 TI 及其代理造成的任何损失。

在某些场合中,为了推进安全相关应用有可能对 TI 组件进行特别的促销。TI 的目标是利用此类组件帮助客户设计和创立其特有的可满足适用的功能安全性标准和要求的终端产品解决方案。尽管如此,此类组件仍然服从这些条款。

TI 组件未获得用于 FDA Class III (或类似的生命攸关医疗设备)的授权许可,除非各方授权官员已经达成了专门管控此类使用的特别协议。

只有那些 TI 特别注明属于军用等级或“增强型塑料”的 TI 组件才是设计或专门用于军事/航空应用或环境的。购买者认可并同意,对并非指定面向军事或航空航天用途的 TI 组件进行军事或航空航天方面的应用,其风险由客户单独承担,并且由客户独立负责满足与此类使用相关的所有法律和法规要求。

TI 已明确指定符合 ISO/TS16949 要求的产品,这些产品主要用于汽车。在任何情况下,因使用非指定产品而无法达到 ISO/TS16949 要求, TI 不承担任何责任。

	产品		应用
数字音频	www.ti.com.cn/audio	通信与电信	www.ti.com.cn/telecom
放大器和线性器件	www.ti.com.cn/amplifiers	计算机及周边	www.ti.com.cn/computer
数据转换器	www.ti.com.cn/dataconverters	消费电子	www.ti.com.cn/consumer-apps
DLP® 产品	www.dlp.com	能源	www.ti.com.cn/energy
DSP - 数字信号处理器	www.ti.com.cn/dsp	工业应用	www.ti.com.cn/industrial
时钟和计时器	www.ti.com.cn/clockandtimers	医疗电子	www.ti.com.cn/medical
接口	www.ti.com.cn/interface	安防应用	www.ti.com.cn/security
逻辑	www.ti.com.cn/logic	汽车电子	www.ti.com.cn/automotive
电源管理	www.ti.com.cn/power	视频和影像	www.ti.com.cn/video
微控制器 (MCU)	www.ti.com.cn/microcontrollers		
RFID 系统	www.ti.com.cn/rfidsys		
OMAP应用处理器	www.ti.com/omap		
无线连通性	www.ti.com.cn/wirelessconnectivity	德州仪器在线技术支持社区	www.deyisupport.com

邮寄地址: 上海市浦东新区世纪大道1568号, 中建大厦32楼邮政编码: 200122
Copyright © 2016, 德州仪器半导体技术(上海)有限公司

PACKAGING INFORMATION

Orderable Device	Status (1)	Package Type	Package Drawing	Pins	Package Qty	Eco Plan (2)	Lead finish/ Ball material (6)	MSL Peak Temp (3)	Op Temp (°C)	Device Marking (4/5)	Samples
BQ25871YFFR	ACTIVE	DSBGA	YFF	42	3000	RoHS & Green	SNAGCU	Level-1-260C-UNLIM	-40 to 85	BQ25871	Samples
BQ25871YFFT	ACTIVE	DSBGA	YFF	42	250	RoHS & Green	SNAGCU	Level-1-260C-UNLIM	-40 to 85	BQ25871	Samples

(1) The marketing status values are defined as follows:

ACTIVE: Product device recommended for new designs.

LIFEBUY: TI has announced that the device will be discontinued, and a lifetime-buy period is in effect.

NRND: Not recommended for new designs. Device is in production to support existing customers, but TI does not recommend using this part in a new design.

PREVIEW: Device has been announced but is not in production. Samples may or may not be available.

OBSOLETE: TI has discontinued the production of the device.

(2) **RoHS:** TI defines "RoHS" to mean semiconductor products that are compliant with the current EU RoHS requirements for all 10 RoHS substances, including the requirement that RoHS substance do not exceed 0.1% by weight in homogeneous materials. Where designed to be soldered at high temperatures, "RoHS" products are suitable for use in specified lead-free processes. TI may reference these types of products as "Pb-Free".

RoHS Exempt: TI defines "RoHS Exempt" to mean products that contain lead but are compliant with EU RoHS pursuant to a specific EU RoHS exemption.

Green: TI defines "Green" to mean the content of Chlorine (Cl) and Bromine (Br) based flame retardants meet JS709B low halogen requirements of <=1000ppm threshold. Antimony trioxide based flame retardants must also meet the <=1000ppm threshold requirement.

(3) MSL, Peak Temp. - The Moisture Sensitivity Level rating according to the JEDEC industry standard classifications, and peak solder temperature.

(4) There may be additional marking, which relates to the logo, the lot trace code information, or the environmental category on the device.

(5) Multiple Device Markings will be inside parentheses. Only one Device Marking contained in parentheses and separated by a "~" will appear on a device. If a line is indented then it is a continuation of the previous line and the two combined represent the entire Device Marking for that device.

(6) Lead finish/Ball material - Orderable Devices may have multiple material finish options. Finish options are separated by a vertical ruled line. Lead finish/Ball material values may wrap to two lines if the finish value exceeds the maximum column width.

Important Information and Disclaimer:The information provided on this page represents TI's knowledge and belief as of the date that it is provided. TI bases its knowledge and belief on information provided by third parties, and makes no representation or warranty as to the accuracy of such information. Efforts are underway to better integrate information from third parties. TI has taken and continues to take reasonable steps to provide representative and accurate information but may not have conducted destructive testing or chemical analysis on incoming materials and chemicals. TI and TI suppliers consider certain information to be proprietary, and thus CAS numbers and other limited information may not be available for release.

In no event shall TI's liability arising out of such information exceed the total purchase price of the TI part(s) at issue in this document sold by TI to Customer on an annual basis.

YFF0042

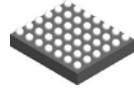

PACKAGE OUTLINE

DSBGA - 0.625 mm max height

DIE SIZE BALL GRID ARRAY

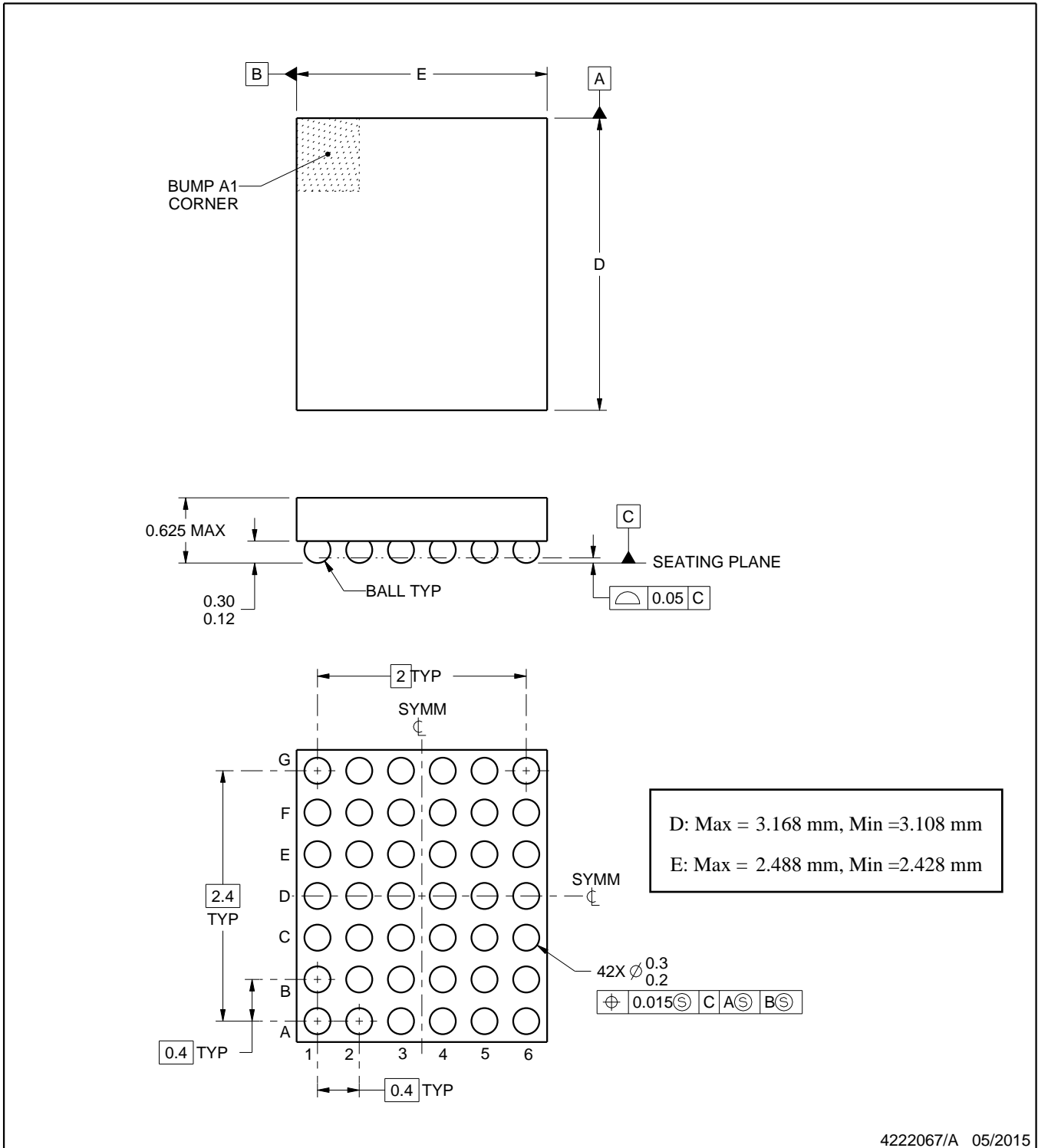

4222067/A 05/2015

NOTES:

1. All linear dimensions are in millimeters. Any dimensions in parenthesis are for reference only. Dimensioning and tolerancing per ASME Y14.5M.
2. This drawing is subject to change without notice.

EXAMPLE BOARD LAYOUT

YFF0042

DSBGA - 0.625 mm max height

DIE SIZE BALL GRID ARRAY

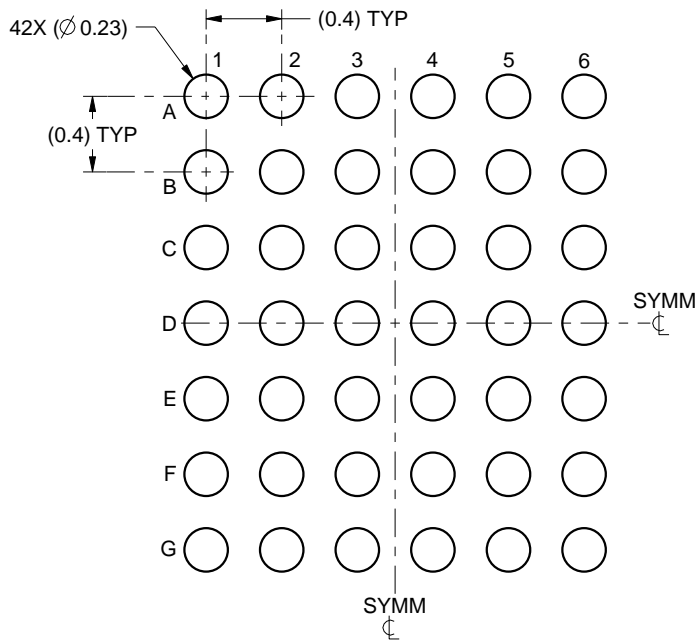

LAND PATTERN EXAMPLE
SCALE:25X

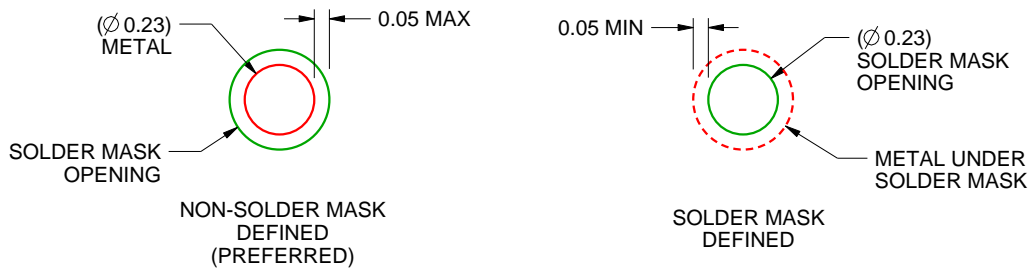

SOLDER MASK DETAILS
NOT TO SCALE

4222067/A 05/2015

NOTES: (continued)

- Final dimensions may vary due to manufacturing tolerance considerations and also routing constraints. For more information, see Texas Instruments literature number SNVA009 (www.ti.com/lit/snva009).

EXAMPLE STENCIL DESIGN

YFF0042

DSBGA - 0.625 mm max height

DIE SIZE BALL GRID ARRAY

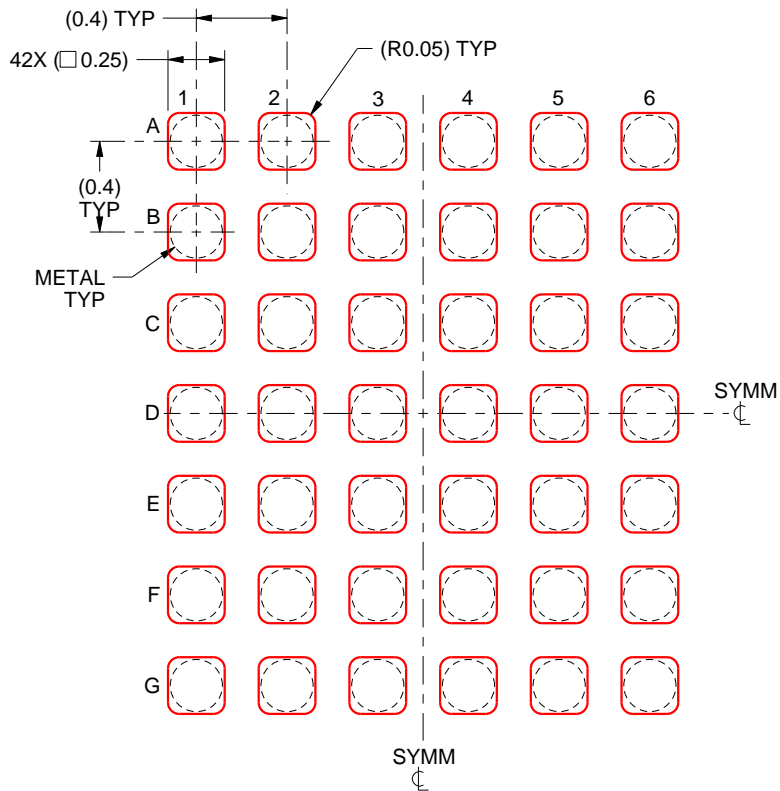

SOLDER PASTE EXAMPLE
BASED ON 0.1 mm THICK STENCIL
SCALE:30X

4222067/A 05/2015

NOTES: (continued)

4. Laser cutting apertures with trapezoidal walls and rounded corners may offer better paste release.

重要声明和免责声明

TI 均以“原样”提供技术性及其可靠性数据（包括数据表）、设计资源（包括参考设计）、应用或其他设计建议、网络工具、安全信息和其他资源，不保证其中不含任何瑕疵，且不做任何明示或暗示的担保，包括但不限于对适销性、适合某特定用途或不侵犯任何第三方知识产权的暗示担保。

所述资源可供专业开发人员应用TI 产品进行设计使用。您将对以下行为独自承担全部责任：(1) 针对您的应用选择合适的TI 产品；(2) 设计、验证并测试您的应用；(3) 确保您的应用满足相应标准以及任何其他安全、安保或其他要求。所述资源如有变更，恕不另行通知。TI 对您使用所述资源的授权仅限于开发资源所涉及TI 产品的相关应用。除此之外不得复制或展示所述资源，也不提供其它TI 或任何第三方的知识产权授权许可。如因使用所述资源而产生任何索赔、赔偿、成本、损失及债务等，TI 对此概不负责，并且您须赔偿由此对TI 及其代表造成的损害。

TI 所提供产品均受TI 的销售条款 (<http://www.ti.com.cn/zh-cn/legal/termsofsale.html>) 以及ti.com.cn上或随附TI产品提供的其他可适用条款的约束。TI提供所述资源并不扩展或以其他方式更改TI 针对TI 产品所发布的可适用的担保范围或担保免责声明。

邮寄地址：上海市浦东新区世纪大道 1568 号中建大厦 32 楼，邮政编码：200122

Copyright © 2020 德州仪器半导体技术（上海）有限公司