

## 用于铅酸电池，具有 Impedance Track™ 功能的宽范围电量计

 查询样品: [bq34z110](#)

### 特性

- 支持铅酸化学电池
  - 使用获得专利的 **Impedance Track™** 技术，用于电压范围为 **4V** 至 **64V** 的电池
    - 老化补偿
    - 自放电补偿
  - 支持的电池容量超过 **65Ahr**
  - 支持高于 **32A** 的充放电电流
  - 外部负温度系数 (**NTC**) 热敏电阻支持
  - 支持两线制 **I<sup>2</sup>C™** 和与主机系统进行通信的 **HDQ** 单线制通信接口
  - 安全哈希算法 (**SHA**)-1, 哈希消息认证码 (**HMAC**) 认证
  - 一个或者四个直接显示控制
  - 五个 **LED** 和通过端口扩展器的更多显示
- 精简的功率模式（典型电池组运行范围条件）
    - 正常运行：平均值 < **140μA**
    - 睡眠模式：平均值 < **64μA**
    - 完全睡眠模式：平均值 < **19μA**
  - 封装：**14** 引脚薄型小外形尺寸封装 (**TSSOP**)

### 应用范围

- 轻型机动车辆
- 电动工具
- 医疗仪表
- 不可中断的电源（不间断电源 (**UPS**)）
- 移动式无线电通信

### 说明

德州仪器 (TI) bq34z110 是一款独立于电池串联配置之外工作的电量计解决方案，此解决方案支持铅酸化学电池。通过一个外部电压转换电路，可支持 **4V** 至 **64V** 的电池，可对此电路进行自动控制以减少系统功耗。

bq34z110 器件提供几个接口选项，其中包括一个 **I<sup>2</sup>C** 从接口、一个 **HDQ** 从接口、一个或者四个直接 **LED** 接口、和一个警报输出引脚。此外，bq34z110 提供对于外部端口扩展器（支持多于四个 **LED**）的支持。

### ORDERING INFORMATION

T <sub>A</sub>	PART NUMBER	PACKAGE (TSSOP)	TUBE	TAPE AND REEL
-40°C to 85°C	bq34z110PW or bq34z110PWR	14-Pin	PW	PWR



Please be aware that an important notice concerning availability, standard warranty, and use in critical applications of Texas Instruments semiconductor products and disclaimers thereto appears at the end of this data sheet.

Impedance Track is a trademark of Texas Instruments.

I<sup>2</sup>C is a trademark of NXP B.V Corporation.



These devices have limited built-in ESD protection. The leads should be shorted together or the device placed in conductive foam during storage or handling to prevent electrostatic damage to the MOS gates.

## PIN DETAILS

### PINOUT DIAGRAM

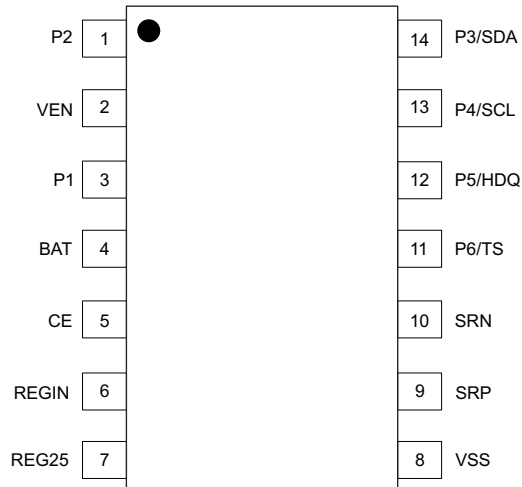

Figure 1. bq34z110 Pinout Diagram

Table 1. bq34z110 External Pin Functions

PIN NAME	PIN NUMBER	TYPE <sup>(1)</sup>	DESCRIPTION
P2	1	O	LED 2 or Not Used (connect to Vss)
VEN	2	O	Active High Voltage Translation Enable. This signal is optionally used to switch the input voltage divider on/off to reduce the power consumption (typ 45 $\mu$ A) of the divider network.
P1	3	O	LED 1 or Not Used (connect to Vss). This pin is also used to drive an LED for single-LED mode. Use a small signal N-FET (Q1) in series with the LED as shown on <a href="#">Figure 9</a> .
BAT	4	I	Translated Battery Voltage Input
CE	5	I	Chip Enable. Internal LDO is disconnected from REGIN when driven low.
REGIN	6	P	Internal integrated LDO input. Decouple with a 0.1- $\mu$ F ceramic capacitor to Vss.
REG25	7	P	2.5-V Output voltage of the internal integrated LDO. Decouple with 1- $\mu$ F ceramic capacitor to Vss.
VSS	8	P	Device ground
SRP	9	I	Analog input pin connected to the internal coulomb-counter peripheral for integrating a small voltage between SRP and SRN where SRP is nearest to the BAT- connection.
SRN	10	I	Analog input pin connected to the internal coulomb-counter peripheral for integrating a small voltage between SRP and SRN where SRN is nearest to the PACK- connection.
P6/TS	11	I	Pack thermistor voltage sense (use 103AT-type thermistor)
P5/HDQ	12	I/O	Open drain HDQ Serial communication line (slave)
P4/SCL	13	I	Slave I <sup>2</sup> C serial communication clock input. Use with a 10-K pull-up resistor (typical). Also used for LED 4 in the four-LED mode.
P3/SDA	14	I/O	Open drain slave I <sup>2</sup> C serial communication data line. Use with a 10-k $\Omega$ pull-up resistor (typical). Also used for LED 3 in the four-LED mode.

(1) I = Input, O = Output, P = Power, I/O = Digital input/output

TYPICAL IMPLEMENTATION

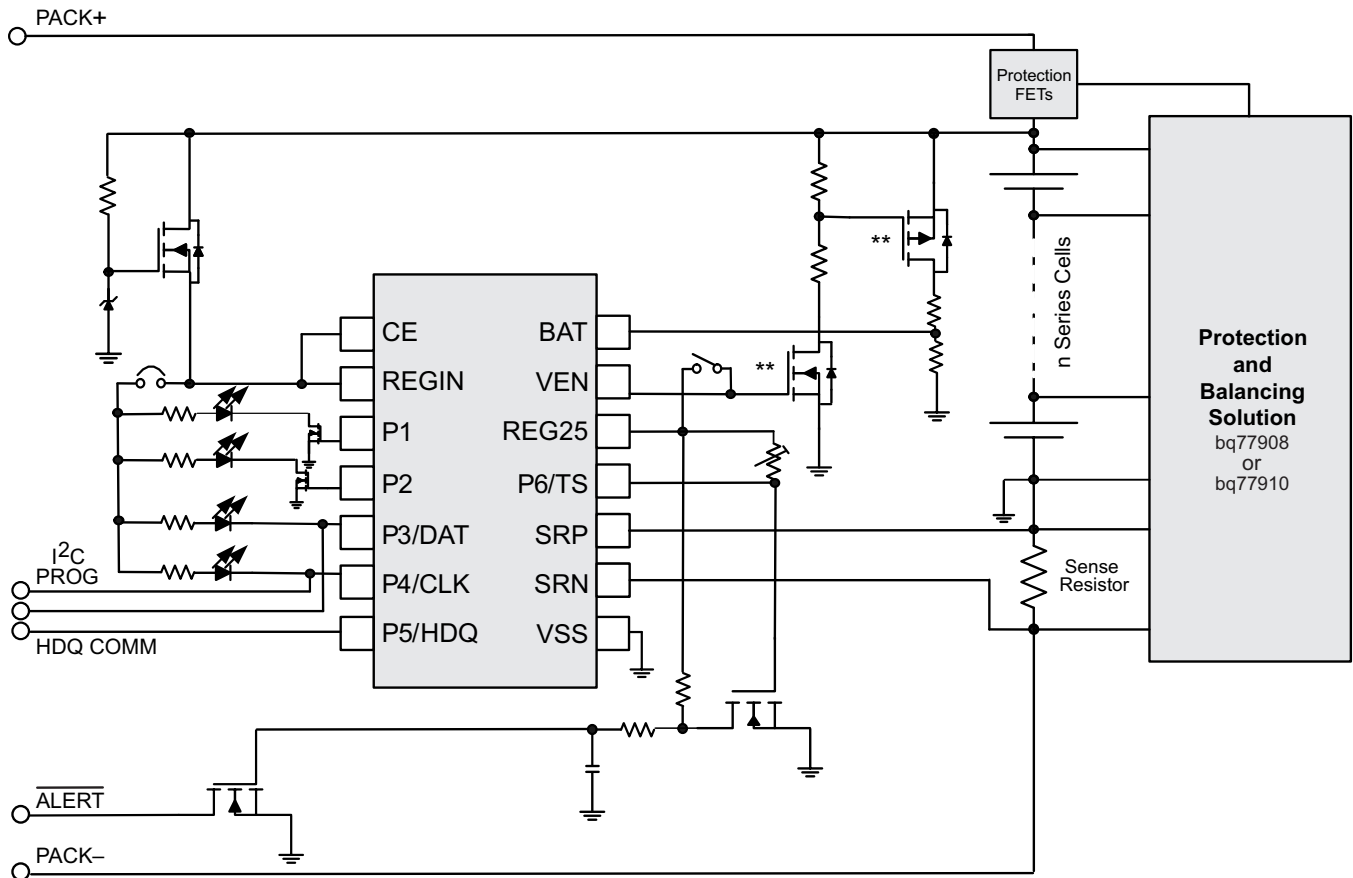

\*\* optional to reduce divider power consumption

Figure 2. bq34z110 Typical Implementation

THERMAL INFORMATION

THERMAL METRIC <sup>(1)</sup>		bq34z110	
		TSSOP (14-Pins)	
			UNITS
$\theta_{JA, High K}$	Junction-to-ambient thermal resistance	103.8	°C/W
$\theta_{JC(top)}$	Junction-to-case(top) thermal resistance	31.9	
$\theta_{JB}$	Junction-to-board thermal resistance	46.6	
$\Psi_{JT}$	Junction-to-top characterization parameter	2.0	
$\Psi_{JB}$	Junction-to-board characterization parameter	45.9	
$\theta_{JC(bottom)}$	Junction-to-case(bottom) thermal resistance	N/A	

(1) 有关传统和新的热 度量的更多信息，请参阅 IC 封装热度量应用报告，SPRA953。

## ABSOLUTE MAXIMUM RATINGS

Over operating free-air temperature range (unless otherwise noted)<sup>(1)</sup>

PARAMETER		VALUE		UNIT
		MIN	MAX	
V <sub>REGIN</sub>	Regulator Input Range	-0.3	5.5	V
V <sub>CC</sub>	Supply Voltage Range	-0.3	2.75	V
V <sub>IOD</sub>	Open-drain I/O pins (SDA, SCL, HDQ)	-0.3	5.5	V
V <sub>BAT</sub>	Bat Input pin	-0.3	5.5	V
V <sub>I</sub>	Input Voltage range to all other pins (P1, P2, SRP, SRN)	-0.3	V <sub>CC</sub> + 0.3	V
ESD	Human-body model (HBM), BAT pin		1.5	kV
	Human-body model (HBM), all other pins		2	kV
T <sub>A</sub>	Operating free-air temperature range	-40	85	°C
T <sub>F</sub>	Functional temperature range	-40	100	°C

(1) Stresses beyond those listed under *absolute maximum ratings* may cause permanent damage to the device. These are stress ratings only, and functional operation of the device at these or any other conditions beyond those indicated under *recommended operating conditions* is not implied. Exposure to absolute-maximum-rated conditions for extended periods may affect device reliability.

## RECOMMENDED OPERATING CONDITIONS

T<sub>A</sub> = 25°C, C<sub>LDO25</sub> = 1 μF, and V<sub>REGIN</sub> = 3.6 V (unless otherwise noted)

PARAMETER		CONDITIONS	MIN	TYP	MAX	UNIT
V <sub>REGIN</sub>	Supply Voltage	No operating restrictions	2.7		4.5	V
		No FLASH writes	2.45		2.7	V
C <sub>REGIN</sub>	External input capacitor for internal LDO between REGIN and VSS	Nominal capacitor values specified. Recommend a 10% ceramic X5R type capacitor located close to the device.		0.1		μF
C <sub>LDO25</sub>	External output capacitor for internal LDO between VCC and VSS		0.47	1		μF
I <sub>CC</sub>	Normal operating-mode current	Gas Gauge in NORMAL mode, I <sub>LOAD</sub> > <b>Sleep Current</b>		140		μA
I <sub>SLP</sub>	SLEEP operating-mode current	Gas Gauge in SLEEP mode, I <sub>LOAD</sub> < Sleep Current		64		μA
I <sub>SLP+</sub>	FULL SLEEP operating-mode current	Gas Gauge in FULL SLEEP mode, I <sub>LOAD</sub> < <b>Sleep Current</b>		19		μA
V <sub>OL</sub>	Output voltage, low (SCL, SDA, HDQ)	I <sub>OL</sub> = 3 mA			0.4	V
V <sub>OH(PP)</sub>	Output voltage, high	I <sub>OH</sub> = -1 mA	V <sub>CC</sub> - 0.5			V
V <sub>OH(OD)</sub>	Output voltage, high (SDA, SCL, HDQ)	External pull-up resistor connected to V <sub>CC</sub>	V <sub>CC</sub> - 0.5			V
V <sub>IL</sub>	Input voltage, low		-0.3		0.6	V
V <sub>IH(OD)</sub>	Input voltage, high (SDA, SCL, HDQ)		1.2		6	V
V <sub>A1</sub>	Input voltage range (TS)		V <sub>SS</sub> - 0.05		1	V
V <sub>A2</sub>	Input voltage range (BAT)		V <sub>SS</sub> - 0.125		5	V
V <sub>A3</sub>	Input voltage range (SRP, SRN)		V <sub>SS</sub> - 0.125		0.125	V
I <sub>LKG</sub>	Input leakage current (I/O pins)				0.3	μA
t <sub>PUCD</sub>	Power-up communication delay			250		ms

## POWER-ON RESET

 $T_A = -40^{\circ}\text{C}$  to  $85^{\circ}\text{C}$ ; Typical Values at  $T_A = 25^{\circ}\text{C}$  and  $V_{\text{REGIN}} = 3.6\text{ V}$  (unless otherwise noted)

PARAMETER		TEST CONDITIONS	MIN	TYP	MAX	UNIT
$V_{\text{IT+}}$	Positive-going battery voltage input at REG25		2.05	2.20	2.31	V
$V_{\text{HYS}}$	Power-on reset hysteresis		45	115	185	mV

## LDO REGULATOR

 $T_A = 25^{\circ}\text{C}$ ,  $C_{\text{LDO25}} = 1\ \mu\text{F}$ ,  $V_{\text{REGIN}} = 3.6\text{ V}$  (unless otherwise noted)<sup>(1)</sup>

PARAMETER		TEST CONDITION	MIN	NOM	MAX	UNIT	
$V_{\text{REG25}}$	Regulator output voltage	$2.7\text{ V} \leq V_{\text{REGIN}} \leq 4.5\text{ V}$ , $I_{\text{OUT}} \leq 16\text{ mA}$	$T_A = -40^{\circ}\text{C}$ to $85^{\circ}\text{C}$	2.3	2.5	2.7	V
		$2.45\text{ V} \leq V_{\text{REGIN}} < 2.7\text{ V}$ (low battery), $I_{\text{OUT}} \leq 3\text{ mA}$	$T_A = -40^{\circ}\text{C}$ to $85^{\circ}\text{C}$	2.3			
$I_{\text{SHORT}}^{(2)}$	Short Circuit Current Limit	$V_{\text{REG25}} = 0\text{ V}$	$T_A = -40^{\circ}\text{C}$ to $85^{\circ}\text{C}$		250	mA	

(1) LDO output current,  $I$ , is the sum of internal and external load currents.

(2) Specified by design. Not production tested.

## INTERNAL TEMPERATURE SENSOR CHARACTERISTICS

 $T_A = -40^{\circ}\text{C}$  to  $85^{\circ}\text{C}$ ,  $2.4\text{ V} < \text{REG25} < 2.6\text{ V}$ ; Typical Values at  $T_A = 25^{\circ}\text{C}$  and  $\text{REG25} = 2.5\text{ V}$  (unless otherwise noted)

PARAMETER		TEST CONDITIONS	MIN	TYP	MAX	UNIT
$G_{\text{TEMP}}$	Temperature sensor voltage gain			-2		mV/ $^{\circ}\text{C}$

## LOW-FREQUENCY OSCILLATOR

 $T_A = -40^{\circ}\text{C}$  to  $85^{\circ}\text{C}$ ,  $2.4\text{ V} < \text{REG25} < 2.6\text{ V}$ ; Typical Values at  $T_A = 25^{\circ}\text{C}$  and  $\text{REG25} = 2.5\text{ V}$  (unless otherwise noted)

PARAMETER		TEST CONDITIONS	MIN	TYP	MAX	UNIT
$f_{(\text{LOSC})}$	Operating frequency			32.768		kHz
$f_{(\text{LEIO})}$	Frequency error <sup>(1)(2)</sup>	$T_A = 0^{\circ}\text{C}$ to $60^{\circ}\text{C}$	-1.5%	0.25%	1.5%	
		$T_A = -20^{\circ}\text{C}$ to $70^{\circ}\text{C}$	-2.5%	0.25%	2.5%	
		$T_A = -40^{\circ}\text{C}$ to $85^{\circ}\text{C}$	-4%	0.25%	4%	
$t_{(\text{LSXO})}$	Start-up time <sup>(2)</sup>			500		$\mu\text{s}$

(1) The frequency drift is included and measured from the trimmed frequency at  $V_{\text{CC}} = 2.5\text{ V}$ ,  $T_A = 25^{\circ}\text{C}$ .

(2) The startup time is defined as the time it takes for the frequency error is measured from 32.768 kHz.

## HIGH-FREQUENCY OSCILLATOR

 $T_A = -40^{\circ}\text{C}$  to  $85^{\circ}\text{C}$ ,  $2.4\text{ V} < \text{REG25} < 2.6\text{ V}$ ; Typical Values at  $T_A = 25^{\circ}\text{C}$  and  $\text{REG25} = 2.5\text{ V}$  (unless otherwise noted)

PARAMETER		TEST CONDITIONS	MIN	TYP	MAX	UNIT
$f_{(\text{OSC})}$	Operating frequency			8.389		MHz
$f_{(\text{EIO})}$	Frequency error <sup>(1)</sup>	$T_A = 0^{\circ}\text{C}$ to $60^{\circ}\text{C}$	-2%	0.38%	2%	
		$T_A = -20^{\circ}\text{C}$ to $70^{\circ}\text{C}$	-3%	0.38%	3%	
		$T_A = -40^{\circ}\text{C}$ to $85^{\circ}\text{C}$	-4.5%	0.38%	4.5%	
$t_{(\text{SXO})}$	Start-up time <sup>(2)</sup>			2.5	5	ms

(1) The frequency drift is included and measured from the trimmed frequency at  $V_{\text{CC}} = 2.5\text{ V}$ ,  $T_A = 25^{\circ}\text{C}$ .

(2) The startup time is defined as the time it takes for the oscillator output frequency to be  $\pm 3\%$ .

## INTEGRATING ADC (COULOMB COUNTER) CHARACTERISTICS

 $T_A = -40^{\circ}\text{C}$  to  $85^{\circ}\text{C}$ ,  $2.4\text{ V} < \text{REG25} < 2.6\text{ V}$ ; Typical Values at  $T_A = 25^{\circ}\text{C}$  and  $\text{REG25} = 2.5\text{ V}$  (unless otherwise noted)

PARAMETER		TEST CONDITIONS	MIN	TYP	MAX	UNIT
$V_{(\text{SR})}$	Input voltage range, $V_{(\text{SRN})}$ and $V_{(\text{SRP})}$	$V_{(\text{SR})} = V_{(\text{SRN})} - V_{(\text{SRP})}$	-0.125		0.125	V
$t_{\text{SR\_CONV}}$	Conversion time	Single conversion		1		s
	Resolution		14		15	bits

## INTEGRATING ADC (COULOMB COUNTER) CHARACTERISTICS (continued)

$T_A = -40^\circ\text{C}$  to  $85^\circ\text{C}$ ,  $2.4\text{ V} < \text{REG25} < 2.6\text{ V}$ ; Typical Values at  $T_A = 25^\circ\text{C}$  and  $\text{REG25} = 2.5\text{ V}$  (unless otherwise noted)

PARAMETER		TEST CONDITIONS	MIN	TYP	MAX	UNIT
$V_{\text{OS(SR)}}$	Input offset			10		$\mu\text{V}$
$I_{\text{NL}}$	Integral nonlinearity error			$\pm 0.007$	$\pm 0.034$	% FSR
$Z_{\text{IN(SR)}}$	Effective input resistance <sup>(1)</sup>		2.5			$\text{M}\Omega$
$I_{\text{lkq(SR)}}$	Input leakage current <sup>(1)</sup>				0.3	$\mu\text{A}$

(1) Specified by design. Not tested in production.

## ADC (TEMPERATURE AND CELL MEASUREMENT) CHARACTERISTICS

$T_A = -40^\circ\text{C}$  to  $85^\circ\text{C}$ ,  $2.4\text{ V} < \text{REG25} < 2.6\text{ V}$ ; Typical Values at  $T_A = 25^\circ\text{C}$  and  $\text{REG25} = 2.5\text{ V}$  (unless otherwise noted)

PARAMETER		TEST CONDITIONS	MIN	TYP	MAX	UNIT
$V_{\text{IN(ADC)}}$	Input voltage range		0.05		1	V
$t_{\text{ADC\_CON}}$	Conversion time				125	ms
	Resolution		14		15	bits
$V_{\text{OS(ADC)}}$	Input offset			1		mV
$Z_{\text{ADC1}}$	Effective input resistance (TS) <sup>(1)</sup>		8			$\text{M}\Omega$
$Z_{\text{ADC2}}$	Effective input resistance (BAT) <sup>(1)</sup>	bq34z110 not measuring cell voltage	8			$\text{M}\Omega$
		bq34z110 measuring cell voltage		100		$\text{K}\Omega$
$I_{\text{lkq(ADC)}}$	Input leakage current <sup>(1)</sup>				0.3	$\mu\text{A}$

(1) Specified by design. Not tested in production.

## DATA FLASH MEMORY CHARACTERISTICS

$T_A = -40^\circ\text{C}$  to  $85^\circ\text{C}$ ,  $2.4\text{ V} < \text{REG25} < 2.6\text{ V}$ ; Typical Values at  $T_A = 25^\circ\text{C}$  and  $\text{REG25} = 2.5\text{ V}$  (unless otherwise noted)

PARAMETER		TEST CONDITIONS	MIN	TYP	MAX	UNIT
$t_{\text{DR}}$	Data retention <sup>(1)</sup>		10			Years
	Flash-programming write cycles <sup>(1)</sup>		20,000			Cycles
$t_{\text{WORDPROG}}$	Word programming time <sup>(1)</sup>				2	ms
$I_{\text{CCPROG}}$	Flash-write supply current <sup>(1)</sup>			5	10	mA

(1) Specified by design. Not tested in production.

## HDQ COMMUNICATION TIMING CHARACTERISTICS

$T_A = -40^\circ\text{C}$  to  $85^\circ\text{C}$ ,  $C_{\text{REG}} = 0.47\text{ }\mu\text{F}$ ,  $2.45\text{ V} < V_{\text{REGIN}} = V_{\text{BAT}} < 5.5\text{ V}$ ; typical values at  $T_A = 25^\circ\text{C}$  and  $V_{\text{REGIN}} = V_{\text{BAT}} = 3.6\text{ V}$  (unless otherwise noted)

PARAMETER		TEST CONDITIONS	MIN	TYP	MAX	UNIT
$t_{\text{(CYCH)}}$	Cycle time, host to bq34z110		190			$\mu\text{s}$
$t_{\text{(CYCD)}}$	Cycle time, bq34z110 to host		190	205	250	$\mu\text{s}$
$t_{\text{(HW1)}}$	Host sends 1 to bq34z110		0.5		50	$\mu\text{s}$
$t_{\text{(DW1)}}$	bq34z110 sends 1 to host		32		50	$\mu\text{s}$
$t_{\text{(HW0)}}$	Host sends 0 to bq34z110		86		145	$\mu\text{s}$
$t_{\text{(DW0)}}$	bq34z110 sends 0 to host		80		145	$\mu\text{s}$
$t_{\text{(RSPS)}}$	Response time, bq34z110 to host		190		950	$\mu\text{s}$
$t_{\text{(B)}}$	Break time		190			$\mu\text{s}$
$t_{\text{(BR)}}$	Break recovery time		40			$\mu\text{s}$
$t_{\text{(RISE)}}$	HDQ line rising time to logic 1 (1.2 V)				950	ns
$t_{\text{(RST)}}$	HDQ Reset		1.8		2.2	s

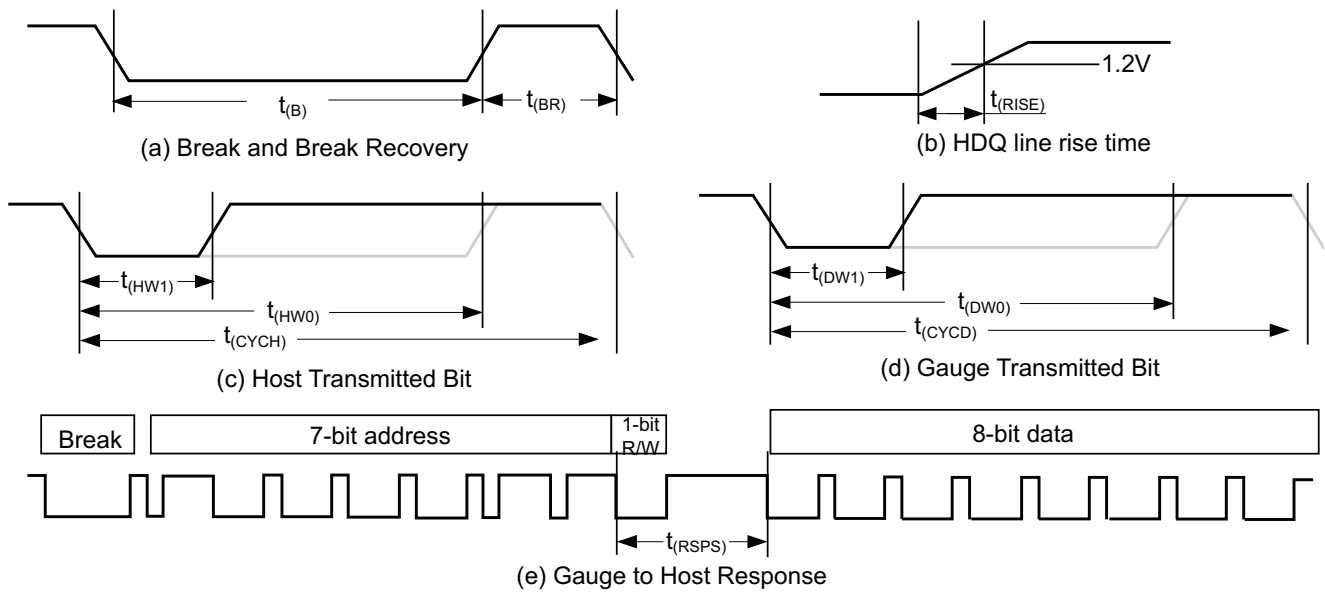

Figure 3. Timing Diagrams

### I<sup>2</sup>C-COMPATIBLE INTERFACE TIMING CHARACTERISTICS

T<sub>A</sub> = -40°C to 85°C, C<sub>REG</sub> = 0.47 μF, 2.45 V < V<sub>REGIN</sub> = V<sub>BAT</sub> < 5.5 V; typical values at T<sub>A</sub> = 25°C and V<sub>REGIN</sub> = V<sub>BAT</sub> = 3.6 V (unless otherwise noted)

PARAMETER	TEST CONDITIONS	MIN	TYP	MAX	UNIT
t <sub>r</sub>	SCL/SDA rise time			300	ns
t <sub>f</sub>	SCL/SDA fall time			300	ns
t <sub>w(H)</sub>	SCL pulse width (high)	600			ns
t <sub>w(L)</sub>	SCL pulse width (low)	1.3			μs
t <sub>su(STA)</sub>	Setup for repeated start	600			ns
t <sub>d(STA)</sub>	Start to first falling edge of SCL	600			ns
t <sub>su(DAT)</sub>	Data setup time	100			ns
t <sub>h(DAT)</sub>	Data hold time	0			ns
t <sub>su(STOP)</sub>	Setup time for stop	600			ns
t <sub>BUF</sub>	Bus free time between stop and start	66			μs
f <sub>SCL</sub>	Clock frequency			400	kHz

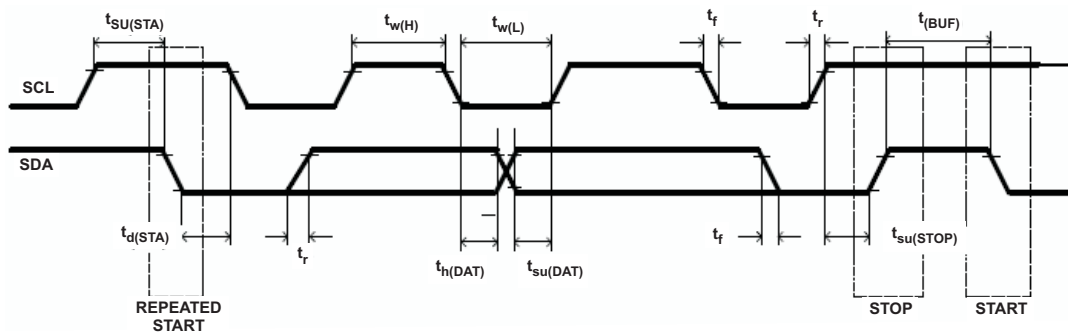

Figure 4. I<sup>2</sup>C-Compatible Interface Timing Diagrams

## GENERAL DESCRIPTION

The bq34z110 accurately predicts the battery capacity and other operational characteristics of multiple rechargeable cells blocks, which are voltage balanced when resting. It supports lead-acid chemistries. It can be interrogated by a host processor to provide cell information, such as Remaining Capacity, Full Charge Capacity, and Average Current.

Information is accessed through a series of commands, called Standard Commands. Further capabilities are provided by the additional Extended Commands set. Both sets of commands, indicated by the general format *Command()*, are used to read and write information contained within the bq34z110 device's control and status registers, as well as its data flash locations. Commands are sent from host to gauge using the bq34z110 serial communications engines, HDQ, and I<sup>2</sup>C, and can be executed during application development, pack manufacture, or end-equipment operation.

Cell information is stored in the bq34z110 in non-volatile flash memory. Many of these data flash locations are accessible during application development and pack manufacture. They cannot, generally, be accessed directly during end-equipment operation. Access to these locations is achieved by either use of the bq34z110 device's companion evaluation software, through individual commands, or through a sequence of data-flash-access commands. To access a desired data flash location, the correct data flash subclass and offset must be known.

The bq34z110 provides 32 bytes of user-programmable data flash memory. This data space is accessed through a data flash interface. For specifics on accessing the data flash, refer to [DATA FLASH INTERFACE](#).

The key to the bq34z110 device's high-accuracy gas gauging prediction is Texas Instrument's proprietary Impedance Track algorithm. This algorithm uses voltage measurements, characteristics, and properties to create state-of-charge predictions that can achieve accuracy with as little as 1% error across a wide variety of operating conditions.

The bq34z110 measures charge and discharge activity by monitoring the voltage across a small-value series sense resistor connected in the low side of the battery circuit. When an application's load is applied, cell impedance is measured by comparing its Open Circuit Voltage (OCV) with its measured voltage under loading conditions.

The bq34z110 can use an NTC thermistor (default is Semitec 103AT or Mitsubishi BN35-3H103FB-50) for temperature measurement, or can also be configured to use its internal temperature sensor. The bq34z110 uses temperature to monitor the battery-pack environment, which is used for fuel gauging and cell protection functionality.

To minimize power consumption, the bq34z110 has three power modes: NORMAL, SLEEP, and FULL SLEEP. The bq34z110 passes automatically between these modes, depending upon the occurrence of specific events.

Multiple modes are available for configuring from one to 16 LEDs as an indicator of remaining state of charge. More than four LEDs require the use of one or two inexpensive SN74HC164 shift register expanders.

A SHA-1 or HMAC-based battery pack authentication feature is also implemented on the bq34z110. When the IC is in UNSEALED mode, authentication keys can be (re)assigned. Alternatively, keys can also be programmed permanently in secure memory by Texas Instruments. A scratch pad area is used to receive challenge information from a host and to export SHA-1/HMAC encrypted responses. See the [AUTHENTICATION](#) section for further details.

---

### NOTE

Formatting conventions in this document:

Commands: *italic* with parentheses and no breaking spaces, e.g. *RemainingCapacity()*.

Data Flash: *italic*, **bold**, and breaking spaces, e.g. **Design Capacity**.

Register Bits and Flags: brackets only, e.g. [TDA] Data

Flash Bits: *italic* and **bold**, e.g. [**LED1**]

Modes and states: ALL CAPITALS, e.g. UNSEALED mode.

---

## DATA COMMANDS

### STANDARD DATA COMMANDS

The bq34z110 uses a series of 2-byte standard commands to enable host reading and writing of battery information. Each standard command has an associated command-code pair, as indicated in [Table 2](#). Because each command consists of two bytes of data, two consecutive HDQ or I<sup>2</sup>C transmissions must be executed both to initiate the command function and to read or write the corresponding two bytes of data. Standard commands are accessible in NORMAL operation. Also, two block commands are available to read Manufacturer Name and Device Chemistry. Read and Write permissions depend on the active access mode.

**Table 2. Standard Commands**

NAME		COMMAND CODE	UNITS	SEALED ACCESS	UNSEALED ACCESS
<i>Control()</i>	CNTL	0x00/0x01	N/A	R/W	R/W
<i>StateOfCharge()</i>	SOC	0x02/0x03	%	R	R
<i>RemainingCapacity()</i>	RM	0x04/0x05	mAh	R	R
<i>FullChargeCapacity()</i>	FCC	0x06/0x07	mAh	R	R
<i>Voltage()</i>	VOLT	0x08/0x09	mV	R	R
<i>AverageCurrent()</i>	AI	0x0a/0x0b	mA	R	R
<i>Temperature()</i>	TEMP	0x0c/0x0d	0.1°K	R	R
<i>Flags()</i>	FLAGS	0x0e/0x0f	N/A	R	R
<i>Mfr Date</i>	DATE	0x6B/0x6c	N/A	R	R
<i>Mfr Name Length</i>	NAMEL	0x6d	N/A	R	R
<i>Mfr Name</i>	NAME	0x6e–0x78	N/A	R	R
<i>Device Chemistry Length</i>	CHEML	0x79	N/A	R	R
<i>Device Chemistry</i>	CHEM	0x7a–0x7d	N/A	R	R
<i>Serial Number</i>	SERNUM	0x7e/0x7f	N/A	R	R

### Control(): 0x00/0x01

Issuing a *Control()* command requires a subsequent two-byte sub-command. These additional bytes specify the particular control function desired. The *Control()* command allows the host to control specific features of the bq34z110 during normal operation, and additional features when the bq34z110 is in different access modes, as described in [Table 3](#).

**Table 3. Control() Subcommands**

CNTL FUNCTION	CNTL DATA	SEALED ACCESS	DESCRIPTION
CONTROL_STATUS	0x0000	Yes	Reports the status of DF Checksum, IT, for example.
DEVICE_TYPE	0x0001	Yes	Reports the device type of 0x0541 (indicating bq34z110)
FW_VERSION	0x0002	Yes	Reports the firmware version on the device type
HW_VERSION	0x0003	Yes	Reports the hardware version of the device type
RESET_DATA	0x0005	No	Returns reset data
PREV_MACWRITE	0x0007	No	Returns previous MAC command code
CHEM_ID	0x0008	Yes	Reports the chemical identifier of the Impedance Track configuration
BOARD_OFFSET	0x0009	No	Forces the device to measure and store the board offset
CC_OFFSET	0x000A	No	Forces the device to measure the internal CC offset
CC_OFFSET_SAVE	0x000B	No	Forces the device to store the internal CC offset
DF_VERSION	0x000C	Yes	Reports the data flash version on the device
SET_FULLSLEEP	0x0010	No	Sets the [FULLSLEEP] bit in the control register to 1
STATIC_CHEM_CHKSUM	0x0017	Yes	Calculates chemistry checksum

**Table 3. Control() Subcommands (continued)**

CNTL FUNCTION	CNTL DATA	SEALED ACCESS	DESCRIPTION
CURRENT	0x0018	Yes	Returns the instantaneous current measured by the gauge
SEALED	0x0020	No	Places the device in SEALED access mode
IT_ENABLE	0x0021	No	Enables the Impedance Track algorithm
CAL_ENABLE	0x002D	No	Toggles calibration mode
RESET	0x0041	No	Forces a full reset of the bq34z110
EXIT_CAL	0x0080	No	Exits calibration mode
ENTER_CAL	0x0081	No	Enters calibration mode
OFFSET_CAL	0x0082	No	Reports internal CC offset in calibration mode

**CONTROL\_STATUS: 0x0000**

Instructs the fuel gauge to return status information to Control addresses 0x00/0x01. The status word includes the following information.

**Table 4. CONTROL\_STATUS Flags**

	Bit 7	Bit 6	Bit 5	Bit 4	Bit 3	Bit 2	Bit 1	Bit 0
High Byte	—	FAS	SS	CALMODE	CCA	BCA	CSV	—
Low Byte	—	—	FULLSLEEP	SLEEP	LDMD	RUP_DIS	VOK	QEN

**FAS:** Status bit that indicates the bq34z110 is in FULL ACCESS SEALED state. Active when set.

**SS:** Status bit that indicates the bq34z110 is in the SEALED State. Active when set.

**CSV:** Status bit that indicates a valid data flash checksum has been generated. Active when set.

**CALMODE:** Status bit that indicates the bq34z110 calibration function is active. True when set. Default is 0.

**CCA:** Status bit that indicates the bq34z110 Coulomb Counter Calibration routine is active. Active when set.

**BCA:** Status bit that indicates the bq34z110 Board Calibration routine is active. Active when set.

**FULLSLEEP:** Status bit that indicates the bq34z110 is in FULLSLEEP mode. True when set. The state can only be detected by monitoring the power used by the bq34z110 because any communication will automatically clear it.

**SLEEP:** Status bit that indicates the bq34z110 is in SLEEP mode. True when set.

**LDMD:** Status bit that indicates the bq34z110 Impedance Track algorithm using constant-power mode. True when set. Default is 0 (constant-current mode).

**RUP\_DIS:** Status bit that indicates the bq34z110 Ra table updates are disabled. True when set.

**VOK:** Status bit that indicates cell voltages are OK for Qmax updates. True when set.

**QEN:** Status bit that indicates the bq34z110 Qmax updates are enabled. True when set.

**DEVICE TYPE: 0x0001**

Instructs the fuel gauge to return the device type to addresses 0x00/0x01.

**FW\_VERSION: 0x0002**

Instructs the fuel gauge to return the firmware version to addresses 0x00/0x01.

**HW\_VERSION: 0x0003**

Instructs the fuel gauge to return the hardware version to addresses 0x00/0x01.

**RESET\_DATA: 0x0005**

Instructs the fuel gauge to return the number of resets performed to addresses 0x00/0x01.

**PREV\_MACWRITE: 0x0007**

Instructs the fuel gauge to return the previous command written to addresses 0x00/0x01. The value returned is limited to less than 0x0020.

**CHEM ID: 0x0008**

Instructs the fuel gauge to return the chemical identifier for the Impedance Track configuration to addresses 0x00/0x01.

**BOARD\_OFFSET: 0x0009**

Instructs the fuel gauge to calibrate board offset. During board offset calibration the [BCA] bit is set.

**CC\_OFFSET: 0x000A**

Instructs the fuel gauge to calibrate the coulomb counter offset. During calibration the [CCA] bit is set.

**CC\_OFFSET\_SAVE: 0x000B**

Instructs the fuel gauge to save calibrate the coulomb counter offset after calibration.

**DF\_VERSION: 0x000C**

Instructs the fuel gauge to return the data flash version to addresses 0x00/0x01.

**SET\_FULLSLEEP: 0x0010**

Instructs the fuel gauge to set the FULLSLEEP bit in Control Status register to 1. This allows the gauge to enter the FULLSLEEP power mode after the transition to SLEEP power state is detected. In FULLSLEEP mode less power is consumed by disabling an oscillator circuit used by the communication engines. For HDQ communication one host message will be dropped. For I<sup>2</sup>C communications, the first I<sup>2</sup>C message will incur a 6 ms–8 ms clock stretch while the oscillator is started and stabilized. A communication to the device in FULLSLEEP will force the part back to the SLEEP mode.

**STATIC\_CHEM\_DF\_CHKSUM: 0x0017**

Instructs the fuel gauge to calculate chemistry checksum as a 16-bit unsigned integer sum of all static chemistry data. The most significant bit (MSB) of the checksum is masked yielding a 15-bit checksum. This checksum is compared with the value stored in the data flash Static Chem DF Checksum. If the value matches, the MSB is cleared to indicate pass. If it does not match, the MSB is set to indicate failure.

**SEALED: 0x0020**

Instructs the fuel gauge to transition from UNSEALED state to SEALED state. The fuel gauge should always be set to SEALED state for use in customer's end equipment.

**IT\_ENABLE: 0x0021**

Forces the fuel gauge to begin the Impedance Track algorithm, sets bit 2 of UpdateStatus and causes the [VOK] and [QEN] flags to be set in the CONTROL STATUS register. [VOK] is cleared if the voltages are not suitable for a Qmax update. Once set, [QEN] cannot be cleared. This command is only available when the fuel gauge is UNSEALED and is typically enabled at the last step of production after system test is completed.

**RESET: 0x0041**

Instructs the fuel gauge to perform a full reset. This command is only available when the fuel gauge is UNSEALED.

**EXIT\_CAL: 0x0080**

Instructs the fuel gauge to exit calibration mode.

**ENTER\_CAL: 0x0081**

Instructs the fuel gauge to enter calibration mode.

**OFFSET\_CAL: 0x0082**

Instructs the fuel gauge to perform offset calibration.

**StateOfCharge(): 0x02 and 0x03**

This read-only function returns an unsigned integer value of the predicted remaining battery capacity expressed as a percentage of *FullChargeCapacity()*, with a range of 0 to 100%.

**RemainingCapacity(): 0x04 and 0x05**

This read-only command pair returns the compensated battery capacity remaining. Units are 1 mAh per bit.

**FullChargeCapacity(): 0x06 and 07**

This read-only command pair returns the compensated capacity of the battery when fully charged. Units are 1 mAh per bit except if X10 mode is selected. In X10 mode, units are 10 mAh per bit. *FullChargeCapacity()* is updated at regular intervals, as specified by the Impedance Track algorithm.

**Voltage(): 0x08 and 0x09**

This read-word function returns an unsigned integer value of the measured cell-pack voltage in mV with a range of 0 V to 65535 mV.

**AverageCurrent(): 0x0a and 0x0b**

This read-only command pair returns a signed integer value that is the average current flow through the sense resistor. It is updated every 1 second. Units are 1 mA per bit except if X10 mode is selected. In X10 mode, units are 10 mA per bit.

**Temperature(): 0x0c and 0x0d**

This read-word function returns an unsigned integer value of the temperature in units of 0.1°K measured by the gas gauge and has a range of 0 to 6553.5 °K. The source of the measured temperature is configured by the *[TEMPS]* bit in the Pack Configuration register (see [EXTENDED DATA COMMANDS](#)).

**Table 5. Temperature Sensor Selection**

TEMPS	Temperature() Source
0	Internal Temperature Sensor
1	TS Input (default)

**Flags(): 0x0e/0x0f**

This read-word function returns the contents of the gas-gauge status register, depicting current operation status.

**Table 6. Flags Bit Definitions**

	Bit 7	Bit 6	Bit 5	Bit 4	Bit 3	Bit 2	Bit 1	Bit 0
High Byte	OTC	OTD	BATHIGH	BATLOW	CHG_INH	RSVD	FC	CHG
Low Byte	OCVTAKEN	ISD	TDD	RSVD	RSVD	SOC1	SOCF	DSG

- OTC:** Over-Temperature in Charge condition is detected. True when set. OTD = Over-Temperature in Discharge condition is detected. True when set.
- BATHIGH:** Battery High bit that indicates a high battery voltage condition. Refer to the data flash **BATTERY HIGH** parameters for threshold settings.
- BATLOW:** Battery Low bit that indicates a low battery voltage condition. Refer to the data flash **BATTERY LOW** parameters for threshold settings.
- CHG\_INH:** Charge Inhibit: unable to begin charging [**Charge Inhibit Temp Low, Charge Inhibit Temp High**]. True when set.
- RSVD:** Reserved.
- FC:** Full-charge is detected. FC is set when charge termination is reached and FC Set% = -1 (see [CHARGING AND CHARGE TERMINATION INDICATION](#) for details) or State of Charge is larger than **FC SET%** and **FC Set%** is not -1. True when set.
- CHG:** (Fast) charging allowed. True when set.
- OCVTAKEN:** Cleared on entry to relax mode and set to 1 when OCV measurement is performed in relax mode.
- ISD:** Internal Short is detected. True when set. TDD = Tab Disconnect is detected. True when set.
- SOC1:** State-of-Charge Threshold 1 reached. True when set.
- SOCF:** State-of-Charge Threshold Final reached. True when set.
- DSG:** Discharging detected. True when set.

## DATA FLASH INTERFACE

### ACCESSING DATA FLASH

The bq34z110 data flash is a non-volatile memory that contains bq34z110 initialization, default, cell status, calibration, configuration, and user information. The data flash can be accessed in several different ways, depending on what mode the bq34z110 is operating in and what data is being accessed.

Commonly accessed data flash memory locations, frequently read by a host, are conveniently accessed through specific instructions (described in [DATA COMMANDS](#)). These commands are available when the bq34z110 is either in UNSEALED or SEALED modes.

Most data flash locations, however, can only be accessible in UNSEALED mode by use of the bq34z110 evaluation software or by data flash block transfers. These locations should be optimized and/or fixed during the development and manufacture processes. They become part of a Golden Image File and can then be written to multiple battery packs. Once established, the values generally remain unchanged during end-equipment operation.

To access data flash locations individually, the block containing the desired data flash location(s) must be transferred to the command register locations, where they can be read to the host or changed directly. This is accomplished by sending the set-up command *BlockDataControl()* (code 0x61) with data 0x00. Up to 32 bytes of data can be read directly from the *BlockData()* command locations 0x40...0x5f, externally altered, then re-written to the *BlockData()* command space. Alternatively, specific locations can be read, altered, and re-written if their corresponding offsets are used to index into the *BlockData()* command space. Finally, the data residing in the command space is transferred to data flash, once the correct checksum for the whole block is written to *BlockDataChecksum()* (command number 0x60).

Occasionally, a data flash CLASS will be larger than the 32-byte block size. In this case, the *DataFlashBlock()* command is used to designate which 32-byte block the desired locations reside in. The correct command address is then given by  $0x40 + \text{offset modulo } 32$ . For example, to access **Terminate Voltage** in the Gas Gauging class, *DataFlashClass()* is issued 80 (0x50) to set the class. Because the offset is 48, it must reside in the second 32-byte block. Hence, *DataFlashBlock()* is issued 0x01 to set the block offset, and the offset used to index into the *BlockData()* memory area is  $0x40 + 48 \text{ modulo } 32 = 0x40 + 16 = 0x40 + 0x10 = 0x50$ .

Reading and writing subclass data are block operations 32 bytes in length. Data can be written in shorter block sizes, however. Blocks can be shorter than 32 bytes in length. Writing these blocks back to data flash does not overwrite data that extend beyond the actual block length.

None of the data written to memory are bounded by the bq34z110—the values are not rejected by the gas gauge. Writing an incorrect value may result in hardware failure due to firmware program interpretation of the invalid data. The data written is persistent, so a Power-On Reset does resolve the fault.

### MANUFACTURER INFORMATION BLOCK

The bq34z110 contains 32 bytes of user programmable data flash storage: **Manufacturer Info Block**. The method for accessing these memory locations is slightly different, depending on whether the device is in UNSEALED or SEALED modes.

When in UNSEALED mode and when 0x00 has been written to *BlockDataControl()*, accessing the Manufacturer Info Block is identical to accessing general data flash locations. First, a *DataFlashClass()* command is used to set the subclass, then a *DataFlashBlock()* command sets the offset for the first data flash address within the subclass. The *BlockData()* command codes contain the referenced data flash data. When writing the data flash, a checksum is expected to be received by *BlockDataChecksum()*. Only when the checksum is received and verified is the data actually written to data flash.

As an example, the data flash location for **Manufacturer Info Block** is defined as having a Subclass = 58 and an Offset = 0 through 31 (32 byte block). The specification of Class = System Data is not needed to address Manufacturer Info Block, but is used instead for grouping purposes when viewing data flash info in the bq34z110 evaluation software.

When in SEALED mode or when 0x01 *BlockDataControl()* does not contain 0x00, data flash is no longer available in the manner used in UNSEALED mode. Rather than issuing subclass information, a designated **Manufacturer Information Block** is selected with the *DataFlashBlock()* command. Issuing a 0x01, 0x02, or 0x03 with this command causes the corresponding information block (A, B, or C, respectively) to be transferred to the command space 0x40...0x5f for editing or reading by the host. Upon successful writing of checksum information to *BlockDataChecksum()*, the modified block is returned to data flash.

---

#### NOTE

Manufacturer Info Block A is “read only” when in SEALED mode.

---

### ACCESS MODES

The bq34z110 provides three security modes which control data flash access permissions according to [Table 7](#). Public Access refers to those data flash locations, specified in [Table 20](#) that are accessible to the user. Private Access refers to reserved data flash locations used by the bq34z110 system. Care should be taken to avoid writing to Private data flash locations when performing block writes in Full Access mode by following the method outlined in [ACCESSING DATA FLASH](#).

**Table 7. Data Flash Access**

Security Mode	DF: Public Access	DF: Private Access
BOOTROM	N/A	N/A
FULL ACCESS	R/W	R/W
UNSEALED	R/W	R/W
SEALED	R	N/A

Although FULL ACCESS and UNSEALED modes appear identical, FULL ACCESS mode allows the bq34z110 to directly transition to BOOTROM mode and also write access keys. The UNSEALED mode lacks these abilities.

### SEALING AND UNSEALING DATA FLASH ACCESS

The bq34z110 implements a key-access scheme to transition between SEALED, UNSEALED, and FULL-ACCESS modes. Each transition requires that a unique set of two keys be sent to the bq34z110 via the *Control()* command (these keys are unrelated to the keys used for SHA-1/HMAC authentication). The keys must be sent consecutively, with no other data being written to the *Control()* register in between. Note that to avoid conflict, the keys must be different from the codes presented in the CNTL DATA column of [Table 3](#) subcommands.

When in SEALED mode the [SS] bit of *Control Status()* is set, but when the UNSEAL keys are correctly received by the bq34z110, the [SS] bit is cleared. When the full access keys are correctly received then the *Flags()* [FAS] bit is cleared.

Both the sets of keys for each level are 2 bytes each in length and are stored in data flash. The UNSEAL key (stored at **Unseal Key 0** and **Unseal Key 1**) and the FULL-ACCESS key (stored at **Full Access Key 0** and **Full Access Key 1**) can only be updated when in FULL-ACCESS mode. The order of the bytes entered through the *Control()* command is the reverse of what is read from the part. For example, if the 1st and 2nd word of the UnSeal Key 0 returns 0x1234 and 0x5678, then *Control()* should supply 0x3412 and 0x7856 to unseal the part.

## FUNCTIONAL DESCRIPTION

### FUEL GAUGING

The bq34z110 measures the cell voltage, temperature, and current to determine the battery SOC based in the Impedance Track algorithm (refer to the *Theory and Implementation of Impedance Track Battery Fuel-Gauging Algorithm* application report [SLUA450] for more information). The bq34z110 monitors charge and discharge activity by sensing the voltage across a small-value resistor (5 mΩ to 20 mΩ typ.) between the SRP and SRN pins and in-series with the cell. By integrating charge passing through the battery, the cell's SOC is adjusted during battery charge or discharge.

The total battery capacity is found by comparing states of charge before and after applying the load with the amount of charge passed. When an application load is applied, the impedance of the cell is measured by comparing the OCV obtained from a predefined function for present SOC with the measured voltage under load. Measurements of OCV and charge integration determine chemical state of charge and Chemical Capacity (Qmax). The initial Qmax value is taken from a cell manufacturers' data sheet multiplied by the number of parallel cells. The parallel value is also used for the value programmed in **Design Capacity**. The bq34z110 acquires and updates the battery-impedance profile during normal battery usage. It uses this profile, along with SOC and the Qmax value, to determine *FullChargeCapacity()* and *StateOfCharge()*, specifically for the present load and temperature. *FullChargeCapacity()* is reported as capacity available from a fully charged battery under the present load and temperature until *Voltage()* reaches the **Terminate Voltage**. *NominalAvailableCapacity()* and *FullAvailableCapacity()* are the uncompensated (no or light load) versions of *RemainingCapacity()* and *FullChargeCapacity()*, respectively.

The bq34z110 has two flags accessed by the *Flags()* function that warns when the battery's SOC has fallen to critical levels. When *RemainingCapacity()* falls below the first capacity threshold, specified in **SOC1 Set Threshold**, the [SOC1] (State of Charge Initial) flag is set. The flag is cleared once *RemainingCapacity()* rises above **SOC1 Clear Threshold**. All units are in mAh.

When *RemainingCapacity()* falls below the second capacity threshold, **SOCF Set Threshold**, the [SOCF] (*State of Charge Final*) flag is set, serving as a final discharge warning. If **SOCF Set Threshold** = -1, the flag is inoperative during discharge. Similarly, when *RemainingCapacity()* rises above **SOCF Clear Threshold** and the [SOCF] flag has already been set, the [SOCF] flag is cleared. All units are in mAh.

The bq34z110 has two additional flags accessed by the *Flags()* function that warn of internal battery conditions. The fuel gauge monitors the cell voltage during relaxed conditions to determine if an internal short has been detected. When this condition occurs, [ISD] will be set. The bq34z110 also has the capability of detecting when a tab has been disconnected in a 2-cell parallel system by actively monitoring the state of health. When this condition occurs, [TDD] is set.

Lead-Acid gauging in the charge direction makes use of four *Charge Efficiency* factors to correct for energy lost due to heat. Lead-Acid charge efficiency is not linear throughout the charging process, as it drops with increasing state of charge.

### IMPEDANCE TRACK VARIABLES

The bq34z110 has several data flash variables that permit the user to customize the Impedance Track algorithm for optimized performance. These variables are dependent upon the power characteristics of the application as well as the cell itself.

#### Load Mode

**Load Mode** is used to select either the constant current or constant power model for the Impedance Track algorithm as used in **Load Select**. See the [Load Select](#) section. When **Load Mode** is 0, the *Constant Current Model* is used (default). When Load Mode is 1, the *Constant Power Model* is used. The [LDMD] bit of CONTROL\_STATUS reflects the status of Load Mode.

#### Load Select

**Load Select** defines the type of power or current model to be used to compute load-compensated capacity in the Impedance Track algorithm. If **Load Mode** = 0 (Constant Current) then the options presented in [Table 8](#) are available.

**Table 8. Current Model Used when Load Mode = 0**

Load Select Value	Current Model Used
0	Average discharge current from previous cycle: There is an internal register that records the average discharge current through each entire discharge cycle. The previous average is stored in this register.
1 (default)	Present average discharge current: This is the average discharge current from the beginning of this discharge cycle until present time.
2	Average Current: based on the <i>AverageCurrent()</i>
3	Current: based on a low-pass-filtered version of <i>AverageCurrent()</i> ( $\tau=14s$ )
4	Design Capacity / 5: C Rate based off of Design Capacity /5 or a C / 5 rate in mA.
5	Use the value specified by <i>AtRate()</i>
6	Use the value in <b>User_Rate-mA</b> : This gives a completely user configurable method.

If **Load Mode = 1 (Constant Power)** then the following options are available:

**Table 9. Constant-Power Model Used when Load Mode = 1**

Load Select Value	Power Model Used
0 (default)	Average discharge power from previous cycle: There is an internal register that records the average discharge power through each entire discharge cycle. The previous average is stored in this register.
1	Present average discharge power: This is the average discharge power from the beginning of this discharge cycle until present time.
2	Average Current x Voltage: based off the <i>AverageCurrent()</i> and <i>Voltage()</i> .
3	Current x Voltage: based on a low-pass-filtered version of <i>AverageCurrent()</i> ( $\tau=14s$ ) and <i>Voltage()</i>
4	Design Energy / 5: C Rate based off of Design Energy /5 or a C / 5 rate in mA .
5	Use whatever value specified by <i>AtRate()</i> .
6	Use the value in <b>User_Rate-mW/cW</b> . This gives a completely user-configurable method.

### Reserve Cap-mAh

**Reserve Cap-mAh** determines how much actual remaining capacity exists after reaching 0 *RemainingCapacity()*, before **Terminate Voltage** is reached. A loaded rate or no-load rate of compensation can be selected for Reserve Cap by setting the [RESCAP] bit in the Pack Configuration register.

### Reserve Cap-mWh/cWh

**Reserve Cap-mWh** determines how much actual remaining capacity exists after reaching 0 *AvailableEnergy()*, before **Terminate Voltage** is reached. A loaded rate or no-load rate of compensation can be selected for Reserve Cap by setting the [RESCAP] bit in the Pack Configuration register.

### Design Energy Scale

**Design Energy Scale** is used to select the scale/unit of a set of data flash parameters. The value of **Design Energy Scale** can be either 1 or 10 only.

When using Design Energy Scale = 10, the value for each of the parameters in [Table 10](#) must be adjusted to reflect the new units. See [X10 MODE](#).

**Table 10. Data Flash Parameter Scale/Unit-Based on Design Energy Scale**

Data Flash Parameter	Design Energy Scale = 1 (default)	Design Energy Scale = 10
Design Energy	mWh	cWh
Reserve Energy-mWh/cWh	mWh	cWh
Avg Power Last Run	mW	cW
User Rate-mW/cW	mWh	cWh
T Rise	No Scale	Scaled by X10

### Dsg Current Threshold

This register is used as a threshold by many functions in the bq34z110 to determine if actual discharge current is flowing into or out of the cell. The default for this register should be sufficient for most applications. This threshold should be set low enough to be below any normal application load current but high enough to prevent noise or drift from affecting the measurement.

### Chg Current Threshold

This register is used as a threshold by many functions in the bq34z110 to determine if actual charge current is flowing into or out of the cell. The default for this register should be sufficient for most applications. This threshold should be set low enough to be below any normal charge current but high enough to prevent noise or drift from affecting the measurement.

### Quit Current, Dsg Relax Time, Chg Relax Time, and Quit Relax Time

The **Quit Current** is used as part of the Impedance Track algorithm to determine when the bq34z110 enters relaxation mode from a current flowing mode in either the charge direction or the discharge direction. The value of Quit Current is set to a default value that should be above the standby current of the host system.

Either of the following criteria must be met to enter relaxation mode:

1.  $|AverageCurrent()| < |Quit Current|$  for Dsg Relax Time.
2.  $|AverageCurrent()| > |Quit Current|$  for Chg Relax Time.

After about 6 minutes in relaxation mode, the bq34z110 attempts to take accurate OCV readings. An additional requirement of  $dV/dt < 4 \mu V/s$  is required for the bq34z110 to perform Qmax updates. These updates are used in the Impedance Track algorithms. It is critical that the battery voltage be relaxed during OCV readings to and that the current is not higher than C/20 when attempting to go into relaxation mode.

**Quit Relax Time** specifies the minimum time required for *AverageCurrent()* to remain above the QuitCurrent threshold before exiting relaxation mode.

### Qmax

**Qmax Cell 0** contains the maximum chemical capacity of the cell and is determined by comparing states of charge before and after applying the load with the amount of charge passed. It also corresponds to capacity at low rate of discharge such as C/20 rate. For high accuracy, this value is periodically updated by the bq34z110 during operation.

Based on the battery cell capacity information, the initial value of chemical capacity should be entered in the **Qmax Cell 0** data flash parameter. The Impedance Track algorithm will update this value and maintain it internally in the gauge.

### Update Status

The Update Status register indicates the status of the Impedance Track algorithm.

**Table 11. Update Status Definitions**

Update Status	Status
0x02	Qmax and Ra data are learned, but Impedance Track is not enabled. This should be the standard setting for a Golden Image File.
0x04	Impedance Track is enabled but Qmax and Ra data are not yet learned.
0x05	Impedance Track is enabled and only Qmax has been updated during a learning cycle.
0x06	Impedance Track is enabled. Qmax and Ra data are learned after a successful learning cycle. This should be the operation setting for end equipment.

This register should only be updated by the bq34z110 during a learning cycle or when *IT\_ENABLE()* subcommand is received. Refer to [STEP 8: Run an Optimization Cycle](#).

### **Avg I Last Run**

The bq34z110 logs the current averaged from the beginning to the end of each discharge cycle. It stores this average current from the previous discharge cycle in this register. This register should never need to be modified. It is only updated by the bq34z110 when required.

### **Avg P Last Run**

The bq34z110 logs the power averaged from the beginning to the end of each discharge cycle. It stores this average power from the previous discharge cycle in this register. To get a correct average power reading the bq34z110 continuously multiplies instantaneous current times *Voltage()* to get power. It then logs this data to derive the average power. This register should never need to be modified. It is only updated by the bq34z110 when the required.

### **Delta Voltage**

The bq34z110 stores the maximum difference of *Voltage()* during short load spikes and normal load, so the Impedance Track algorithm can calculate remaining capacity for pulsed loads. It is not recommended to change this value.

### **The Ra Tables**

This data is automatically updated during device operation. No user changes should be made except for reading the values from another pre-learned pack for creating Golden Image Files. Profiles have format *Cell0 R\_a M*, where M is the number that indicates the state of charge to which the value corresponds.

## **CHARGE EFFICIENCY**

Tracking State of Charge during the charge phase is relatively easy with modern chemistries such as Lithium-Ion, where essentially none of the applied energy from the charger is lost to heat. However, lead-acid chemistries may demonstrate significant losses to heat during charging. Therefore, to more accurately track state of charge and Time-to-Full during the charge phase, the bq34z110 uses four charge-efficiency factors to compensate for charge acceptance. These factors are **Charge Efficiency**, **Charge Efficiency Reduction Rate**, **Charge Efficiency Drop Off**, and **Charge Efficiency Temperature Compensation**.

The bq34z110 applies the **Charge Efficiency**, when *RelativeStateOfCharge()* is less than the value coded in **Charge Efficiency Drop Off**. When *RelativeStateOfCharge()* is greater than or equal to the value coded in **Charge Efficiency Drop Off**, **Charge Efficiency** and **Charge Efficiency Reduction Rate** determine the charge efficiency rate. **Charge Efficiency Reduction Rate** defines the percent efficiency reduction per percentage point of *RelativeStateOfCharge()* over **Charge Efficiency Drop Off**. Note that the **Charge Efficiency Reduction Rate** has units of 0.1%.

The bq34z110 also adjusts the efficiency factors for temperature. **Charge Efficiency Temperature Compensation** defines the percent efficiency reduction per degree C over 25°C. Note that **Charge Efficiency Temperature Compensation** has units of 0.01%.

Applying the four factors:

Effective Charge Efficiency % = **Charge Efficiency** – **Charge Efficiency Reduction Rate** [*RSOC()* – **Charge Efficiency Drop Off**] – **Charge Efficiency Temperature Compensation** [Temperature – 25°C]

Where:

$RSOC() \geq \text{Charge Efficiency}$  and  $\text{Temperature} \geq 25^\circ\text{C}$

## **PACK CONFIGURATION REGISTER**

Some bq34z110 pins are configured via the **Pack Configuration** data flash register, as indicated in [Table 12](#). This register is programmed/read via the methods described in [ACCESSING DATA FLASH](#). The register is located at subclass = 64, offset = 0.

**Table 12. Pack Configuration Register Bits**

	Bit 7	Bit 6	Bit 5	Bit 4	Bit 3	Bit 2	Bit 1	Bit 0
High Byte	RESCAP	CALEN	RSVD	RSVD	VOLTSEL	IWAKE	RSNS1	RSNS0
Low Byte	X10	RESFACTSTEP	SLEEP	RMFCC	RSVD	RSVD	RSVD	TEMPS

**RESCAP:** No-load rate of compensation is applied to the reserve capacity calculation. True when set. Default is 0.

**CALEN:** When enabled, entering calibration mode is permitted. For special use only. Default = 0.

**RSVD:** Reserved. Default = 0.

**VOLTSEL:** This bit selects between use of internal or external battery voltage divider. The internal divider is for single cell use only. 1 = external. 0 = internal. Default is 0.

**IWAKE/RSNS1/RSNS0:** These bits configure the current wake function (see [Table 16](#)). Default is 0/0/1.

**X10:** X10 Capacity and/or Current bit. The mA, mAh, and cWh settings and reports will take on a value of ten times normal. This setting has no actual effect within the gauge. It is the responsibility of the host to reinterpret the reported values. X10 current measurement is achieved by calibrating the current measurement to a value X10 lower than actual.

**RESFACTSTEP:** Enables Ra step up/down to Max/Min Res Factor before disabling Ra updates. Default is 1.

**SLEEP:** The fuel gauge can enter sleep, if operating conditions allow. True when set. Default is 1.

**RMFCC:** RM is updated with the value from FCC, on valid charge termination. True when set. Default is 1.

**RSVD:** Reserved. Do not use.

**TEMPS:** Selects external thermistor for *Temperature()* measurements. True when set. Uses internal temp when clear. Default is 1

## TEMPERATURE MEASUREMENT

The bq34z110 can measure temperature via the on-chip temperature sensor or via the TS input depending on the setting of the [TEMPS] bit *PackConfiguration()*. The bit is set by using the *PackConfiguration()* function, described in [EXTENDED DATA COMMANDS](#).

Temperature measurements are made by calling the *Temperature()* function (see [STANDARD DATA COMMANDS](#) for specific information).

When an external thermistor is used, REG25 (pin 7) is used to bias the thermistor and TS (pin 11) is used to measure the thermistor voltage (a pull-down circuit is implemented inside the bq34z110). The bq34z110 then correlates the voltage to temperature, assuming the thermistor is a Semitec 103AT or similar device.

## OVERTEMPERATURE INDICATION

### Overtemperature: Charge

If during charging, *Temperature()* reaches the threshold of *DF:OT Chg* for a period of **OT Chg Time** and *AverageCurrent()* > **Chg Current Threshold**, then the [OTC] bit of *Flags()* is set. Note: if *OT Chg Time* = 0 then feature is completely disabled.

When *Temperature()* falls to **OT Chg Recovery**, the [OTC] of *Flags()* is reset.

### Overtemperature: Discharge

If, during discharging, *Temperature()* reaches the threshold of *OT Dsg* for a period of *OT Dsg Time*, and *AverageCurrent()* ≤ -Dsg Current Threshold, then the [OTD] bit of *Flags()* is set.

### NOTE

If *OT Dsg Time* = 0, then the feature is completely disabled.

When *Temperature()* falls to OT Dsg Recovery, the [*OTD*] bit of *Flags()* is reset.

### CHARGING AND CHARGE TERMINATION INDICATION

For proper bq34z110 operation, the battery charging voltage must be specified by the user. The default value for this variable is **Charging Voltage** = 4200 mV. This parameter should be set to the recommended charging voltage for the entire battery stack.

The bq34z110 detects charge termination when (1) during two consecutive periods of *Current Taper Window*, the *AverageCurrent()* is < **Taper Current** and (2) during the same periods, the accumulated change in capacity > 0.25 mAh / **Taper Current Window** and (3) *Voltage()* > **Charging Voltage - Charging Taper Voltage**. When this occurs, the [CHG] bit of *Flags()* is cleared. Also, if the [*RMFCC*] bit of Pack Configuration is set, and *RemainingCapacity()* is set equal to *FullChargeCapacity()*.

### X10 MODE

The bq34z110 supports high current and high capacity batteries above 32.76 Amperes and 32.76 Ampere-Hours by switching to a times-ten mode where currents and capacities are internally handled correctly, but various reported units and configuration quantities are rescaled to tens of milliamps and tens of milliamp-hours. The need for this is due to the standardization of a two byte data command having a maximum representation of ±32767. When the X10 bit (Bit 7) is set in the Pack Configuration register, all of the mAh, cWh, and mWh settings will take on a value of ten times normal. When this bit is set, the actual units for all capacity and energy parameters will be 10 mAh or Wh. This includes reporting of Remaining Capacity. This bit will also be used to rescale the current reporting to 10 times normal, up to ±327 A. The actual resolution then becomes 10 mA.

It is important to know that setting the X10 flag does not actually change anything in the operation of the gauge. It serves as a notice to the host that the various reported values should be reinterpreted ten times higher. X10 Current measurement is achieved by calibrating the current gain to a value X10 lower than actually applied. Because the flag has no actual effect, it can be used to represent other scaling values. See [Design Energy Scale](#).

### REMAINING STATE OF CHARGE LED INDICATION

The bq34z110 supports multiple options for using one to sixteen LEDs as an output device to display the remaining state of charge. The LED/Comm Configuration register determines the behavior.

**Table 13. LED/COMM Configuration Bits**

Bit 7	Bit 6	Bit 5	Bit 4	Bit 3	Bit 2	Bit 1	Bit 0
XLED3	XLED2	XLED1	XLED0	LEDON	Mode2	Mode1	Mode0

Bits 0, 1, 2 are a code for one of five modes. 0 = No LED, 1 = Single LED, 2 = Four LEDs, 3 = External LEDs with I<sup>2</sup>C comm, 4 = External LEDs with HDQ comm.

Setting Bit 3, LEDON, will cause the LED display to be always on, except in Single LED mode. When clear (default), the LED pattern will only be displayed after holding an LED display button for one to two seconds. The button applies 2.5 V from REG25 pin 7 to VEN pin 2 (refer to ). The **LED Hold Time** parameter may be used to configure how long the LED display remains on if LEDON is clear. **LED Hold Time** configures the update interval for the LED display if LEDON is set.

Bits 4, 5, 6, and 7 are a binary code for number of external LEDs. Code 0 is reserved. Codes 1 through 15 represents 2~16 external LEDs. So, number of External LEDs is 1 + Value of the 4-bit binary code. Display of Remaining Capacity is evenly divided among the selected number of LEDs.

Upon detecting A/D value representing 2.5 V on VEN pin, Single LED mode toggles the LED as duty cycle on within a period of one second. So, for example 10% RSOC will have the LED on for 100 ms and off for 900 ms. 90% RSOC has the LED on for 900 ms and off for 100 ms. Any value >90% displays as 90%.

Upon detecting A/D value representing 2.5 V on VEN pin, Four-LED mode will display the RSOC by driving pins RC2(LED1), RC0(LED2), RA1(LED3), RA2(LED4) in a proportional manner where each LED represents 25% of the remaining state of charge. For example, if RSOC = 67%, three LEDs will be illuminated.

Upon detecting A/D value representing 2.5 V on the VEN pin, External LED mode will transmit the RSOC into an SN74HC164 (for 2~8 LEDs) or two SN74HC164 devices (for 9 to approximately 16 LEDs) using a bit-banged approach with RC2 as Clock and RC0 as Data (see [Figure 9](#)). LEDs are lit for number of seconds as defined in a data flash parameter. See the *SN54HC164, SN74HC164 8-Bit Parallel-Out Serial Shift Registers Data Sheet (SCLS115E)* for detail on these devices.

Extended commands are available to turn the LEDs on and off for test purposes.

## ALERT SIGNAL

Based on the selected LED mode, various options are available for the hardware implementation of an Alert signal. Software configuration of the Alert Configuration register determines which alert conditions will assert the Alert pin.

**Table 14. Alert Signal Pins**

Mode	Description	Alert Pin	Alert Pin Name	Config Register Hex Code	Comment
0	No LED	1	P2	0	
1	Single LED	1	P2	1	
2	4 LED	11	P6	2	Filter and FETs are required to eliminate temperature sense pulses (see <a href="#">Figure 9</a> ).
3	5-LED Expander with I <sup>2</sup> C Host Comm	12	P5	43	
3	10-LED Expander with I <sup>2</sup> C Host Comm	12	P5	93	
4	5-LED Expander with HDQ Host Comm	13	P4	44	
4	10-LED Expander with HDQ Host Comm	13	P4	94	

The port used for the Alert output depends on the mode setting in **LED/Comm Configuration** as defined in [Table 14](#). The default mode is 0. The Alert pin will be asserted by driving LOW. However, note that in LED/COM mode 2, pin TS/P6, which has a dual purpose as temperature sense pin will be driven low except when temperature measurements are made each second. Refer to the reference schematic for filter implementation details if host alert sensing requires a continuous signal.

The Alert pin will be a logical OR of the selected bits in the new configuration register when asserted in the Flags register. Default value for Alert Configuration register is 0.

**Table 15. Alert Configuration Register Bit Definitions**

	Bit 7	Bit 6	Bit 5	Bit 4	Bit 3	Bit 2	Bit 1	Bit 0
High Byte	OTC	OTD	BATHIGH	BATLOW	CHG_INH	RSVD	FC	CHG
Low Byte	RSVD	ISD	TDD	RSVD	RSVD	SOC1	SOCF	DSG

**OTC:** Overtemperature in Charge condition is detected. Alert enabled when set.

**OTD:** Overtemperature in Discharge condition is detected. Alert enabled when set.

**BATHIGH:** Battery High bit that indicates a high battery voltage condition. Refer to the data flash **BATTERY HIGH** parameters for threshold settings. Alert enabled when set.

**BATLOW:** Battery Low bit that indicates a low battery voltage condition. Refer to the data flash **BATTERY LOW** parameters for threshold settings. Alert enabled when set.

**CHG\_INH:** Charge Inhibit: unable to begin charging [**Charge Inhibit Temp Low, Charge Inhibit Temp High**]. Alert enabled when set.

**RSVD:** Reserved. Do not use.

**FC:** Full-charge is detected. FC is set when charge termination is reached and **FC Set%** = -1 (see [CHARGING AND CHARGE TERMINATION INDICATION](#) for details) or State of Charge is larger than **FC Set%** and **FC Set%** is not -1. Alert enabled when set.

**CHG:** (Fast) charging allowed. Alert enabled when set.

**RSVD:** Reserved. Do not use.

**ISD:** Internal Short is detected. Alert enabled when set.

**TDD:** Tab Disconnect is detected. Alert enabled when set.

**SOC1:** State-of-Charge Threshold 1 reached. Alert enabled when set.

**SOCF:** State-of-Charge Threshold Final reached. Alert enabled when set.

**DSG:** Discharging detected. Alert enabled when set.

## POWER MODES

The bq34z110 has three power modes: NORMAL mode, SLEEP mode, and FULLSLEEP mode.

- In NORMAL mode, the bq34z110 is fully powered and can execute any allowable task.
- In SLEEP mode, the gas gauge exists in a reduced-power state, periodically taking measurements and performing calculations.
- In FULLSLEEP mode, the high frequency oscillator is turned off, and power consumption is further reduced compared to SLEEP mode.

### NORMAL Mode

The gas gauge is in NORMAL mode when not in any other power mode. During this mode, *AverageCurrent()*, *Voltage()* and *Temperature()* measurements are taken, and the interface data set is updated. Decisions to change states are also made. This mode is exited by activating a different power mode.

### SLEEP Mode

SLEEP mode is entered automatically if the feature is enabled (**Pack Configuration [SLEEP]** = 1) and *Average Current()* is below the programmable level *Sleep Current*. Once entry to sleep has been qualified but prior to entry to SLEEP mode, the bq34z110 performs an ADC autocalibration to minimize offset. Entry to SLEEP mode can be disabled by the *[SLEEP]* bit of *Pack Configuration()*, where 0 = disabled and 1 = enabled. During SLEEP mode, the bq34z110 periodically wakes to take data measurements and updates the data set, after which it then returns directly to SLEEP. The bq34z110 exits SLEEP if any entry condition is broken, a change in protection status occurs, or a current in excess of  $I_{WAKE}$  through  $R_{SENSE}$  is detected.

### FULLSLEEP Mode

FULLSLEEP mode is entered automatically when the bq34z110 is in SLEEP mode and the timer counts down to 0 (*Full Sleep Wait Time* > 0). FULLSLEEP mode is disabled when *Full Sleep Wait Time* is set to 0.

During FULLSLEEP mode, the bq34z110 periodically takes data measurements and updates its data set. However, a majority of its time is spent in an idle condition.

The gauge exits the FULLSLEEP mode when there is any communication activity. Therefore, the execution of *SET\_FULLSLEEP* sets *[FULLSLEEP]* bit, but the EVSW might still display the bit clear. The FULLSLEEP mode can be verified by measuring the current consumption of the gauge. In this mode, the high frequency oscillator is turned off. The power consumption is further reduced compared to the SLEEP mode.

While in FULLSLEEP mode, the fuel gauge can suspend serial communications as much as 4 ms by holding the communication line(s) low. This delay is necessary to correctly process host communication since the fuel gauge processor is mostly halted. For HDQ communication one host message will be dropped.

## POWER CONTROL

### RESET FUNCTIONS

When the bq34z110 detects either a hardware or software reset (/MRST pin driven low or the [RESET] bit of *Control()* initiated, respectively), it determines the type of reset and increments the corresponding counter. This information is accessible by issuing the command *Control()* function with the RESET\_DATA subcommand.

As shown in [Figure 5](#), if a partial reset was detected, a RAM checksum is generated and compared against the previously stored checksum. If the checksum values do not match, the RAM is reinitialized (a “Full Reset”). The stored checksum is updated every time RAM is altered.

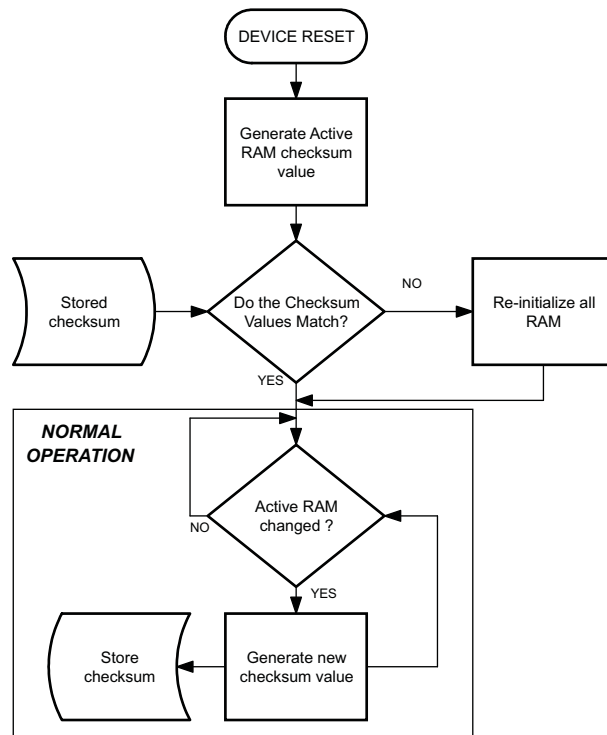

Figure 5. Partial Reset Flow Diagram

## WAKE-UP COMPARATOR

The wake up comparator is used to indicate a change in cell current while the bq34z110 is in SLEEP mode. *PackConfiguration()* uses bits [RSNS1–RSNS0] to set the sense resistor selection. *PackConfiguration()* uses the [IWAKE] bit to select one of two possible voltage threshold ranges for the given sense resistor selection. An internal interrupt is generated when the threshold is breached in either charge or discharge directions. A setting of 0x00 of RSNS1..0 disables this feature.

**Table 16. I<sub>WAKE</sub> t = Threshold Settings<sup>(1)</sup>**

RSNS1	RSNS0	I <sub>WAKE</sub>	V <sub>th</sub> (SRP–SRN)
0	0	0	Disabled
0	0	1	Disabled
0	1	0	+1.25 mV or –1.25 mV
0	1	1	+2.5 mV or –2.5 mV
1	0	0	+2.5 mV or –2.5 mV
1	0	1	+5 mV or –5 mV
1	1	0	+5 mV or –5 mV
1	1	1	+10 mV or –10 mV

(1) The actual resistance value vs. the setting of the sense resistor is not important just the actual voltage threshold when calculating the configuration.

## FLASH UPDATES

Data flash can only be updated if *Voltage()* ≥ *Flash Update OK Voltage*. Flash programming current can cause an increase in LDO dropout. The value of *Flash Update OK Voltage* should be selected such that the bq34z110 Vcc voltage does not fall below its minimum of 2.4 V during Flash write operations. The default value of 2800 mV is appropriate.

## VOLTAGE DIVISION AND CALIBRATION

The bq34z110 is shipped with factory configuration for the default case of 2-series lead-acid cell. This can be changed by setting the number of series cells in the data flash configuration section.

Multi-cell applications, with voltages up to 65535 mV may be gauged by using the appropriate input scaling resistors such that the maximum battery voltage, under all conditions, appears at the BAT input as approximately 900 mV. The actual gain function is determined by a calibration process and the resulting voltage calibration factor is stored in the data flash location **Voltage Divider**.

For two-cell applications, an external divider network is not required. Inside the IC, behind the BAT pin is a nominal 5:1 voltage divider with 88 K $\Omega$  in the top leg and 22 K $\Omega$  in the bottom leg. This internal divider network is enabled by clearing the VOLTSEL bit in the Pack Configuration register. This ratio is optimum for directly measuring a dual cell lead-acid cell where charge voltage is limited to 5 V max.

For higher voltage applications, an external resistor divider network should be implemented as per the reference designs in this document. The quality of the divider resistors is very important to avoid gauging errors over time and temperature. It is recommended to use 0.1% resistors with 25 ppm temperature coefficient. Alternately, a matched network could be used that tracks its dividing ratio with temperature and age due to the similar geometry of each element. Calculation of the series resistor can be made per the equation below. Note that exceeding **V<sub>IN max mV</sub>** results in a measurement with degraded linearity.

The bottom leg of the divider resistor should be in the range of 15 K $\Omega$  to 25 K $\Omega$ . Assuming the use of 16.5 K $\Omega$ :

$$R_{series} = 16500 \Omega (V_{IN \text{ max mV}} - 900 \text{ mV}) / 900 \text{ mV}$$

For all applications, the **Voltage Divider** value in data flash is used by the firmware to calibrate the total divider ratio. The nominal value for this parameter is the maximum expected value for the stack voltage. The calibration routine adjusts the value to force the reported voltage to equal the actual applied voltage.

### 2S EXAMPLE

For stack voltages under 5 V max, it is not necessary to provide an external voltage divider network. The internal 5:1 divider should be selected by clearing the VOLTSEL bit in the Pack Configuration register. The default value for **Voltage Divider** is 5000 (representing the internal 5000:1000 mV divider) when no external divider resistor is used, and the default number of series cells = 2. In the 2S case, there is usually no requirement to calibrate the voltage measurement, since the internal divider is calibrated during factory test to within 2 mV.

### 6S EXAMPLE

In the multi-cell case, the hardware configuration is different. An external voltage divider network is calculated using the Rseries formula above. The bottom leg of the divider should be in the range of 15 K $\Omega$  to 25 K $\Omega$ . For more details on configuration, see [DESIGN STEPS](#).

### AUTOCALIBRATION

The bq34z110 provides an autocalibration feature that will measure the voltage offset error across SRP and SRN from time-to-time as operating conditions change. It subtracts the resulting offset error from normal sense resistor voltage, V<sub>SR</sub>, for maximum measurement accuracy.

The gas gauge performs a single offset calibration when (1) the interface lines stay low for a minimum of **Bus Low Time** and (2) V<sub>sr</sub> > **Deadband**.

The gas gauge also performs a single offset when (1) the condition of  $AverageCurrent() \leq \text{Autocal Min Current}$  and (2) {voltage change since last offset calibration  $\geq \text{Delta Voltage}$ } or {temperature change since last offset calibration is greater than **Delta Temperature** for  $\geq \text{Autocal Time}$ }.

Capacity and current measurements should continue at the last measured rate during the offset calibration when these measurements cannot be performed. If the battery voltage drops more than **Cal Abort** during the offset calibration, the load current has likely increased considerably; hence, the offset calibration is aborted.

## COMMUNICATIONS

### AUTHENTICATION

The bq34z110 can act as a SHA-1 and HMAC authentication slave by using its internal engine. Sending a 160-bit SHA-1 challenge message to the bq34z110 causes the IC to return a 160-bit digest, based upon the challenge message and hidden plain-text authentication keys. When this digest matches an identical one, generated by a host or dedicated authentication master (operating on the same challenge message and using the same plain text keys), the authentication process is successful.

The bq34z110 contains a default plain-text authentication key of 0x0123456789ABCDEFEDCBA987654321. If using the bq34z110 device's internal authentication engine, the default key can be used for development purposes, but should be changed to a secret key and the part immediately sealed, before putting a pack into operation.

### KEY PROGRAMMING

When the bq34z110 device's SHA-1 and HMAC internal engine is used, authentication keys are stored as plain-text in memory. A plain-text authentication key can only be written to the bq34z110 while the IC is in UNSEALED mode. Once the IC is UNSEALED, a 0x00 is written to *BlockDataControl()* to enable the authentication data commands. Next, subclass ID and offset are specified by writing 0x70 and 0x00 to *DataFlashClass()* and *DataFlashBlock()*, respectively. The bq34z110 is now prepared to receive the 16-byte plain-text key, which must begin at command location 0x4C. The key is accepted once a successful checksum has been written to *BlockDataChecksum()*, for the entire 32-byte block (0x40 through 0x5f), not just the 16-byte key.

### EXECUTING AN AUTHENTICATION QUERY

To execute an authentication query in UNSEALED mode, a host must first write 0x01 to the *BlockDataControl()* command, to enable the authentication data commands. If in SEALED mode, 0x00 must be written to *DataFlashBlock()*, instead.

Next, the host writes a 20-byte authentication challenge to the *AuthenticateData()* address locations (0x40 through 0x53). After a valid checksum for the challenge is written to *AuthenticateChecksum()*, the bq34z110 uses the challenge to perform its own the SHA-1/HMAC computation, in conjunction with its programmed keys. The resulting digest is written to *AuthenticateData()*, overwriting the pre-existing challenge. The host may then read this response and compare it against the result created by its own parallel computation.

### HDQ SINGLE-PIN SERIAL INTERFACE

The HDQ interface is an asynchronous return-to-one protocol where a processor sends the command code to the bq34z110. With HDQ, the least significant bit (LSB) of a data byte (command) or word (data) is transmitted first. Note that the DATA signal on pin 12 is open-drain and requires an external pull-up resistor. The 8-bit command code consists of two fields: the 7-bit HDQ command code (bits 0–6) and the 1-bit R/W field (MSB Bit 7). The R/W field directs the bq34z110 either to

- Store the next 8 or 16 bits of data to a specified register or
- Output 8 or 16 bits of data from the specified register

The HDQ peripheral can transmit and receive data as either an HDQ master or slave.

The return-to-one data bit frame of HDQ consists of three distinct sections. The first section is used to start the transmission by either the host or by the bq34z110 taking the DATA pin to a logic-low state for a time  $t_{STRH,B}$ . The next section is for data transmission, where the data are valid for a time  $t_{DSU}$ , after the negative edge used to start communication. The data are held until a time  $t_{DV}$ , allowing the host or bq34z110 time to sample the data bit. The final section is used to stop the transmission by returning the DATA pin to a logic-high state by at least a time  $t_{SSU}$ , after the negative edge used to start communication. The final logic-high state is held until the end of  $t_{CYCH,B}$ , allowing time to ensure the transmission was stopped correctly. The timing for data and break communication is shown in [HDQ COMMUNICATION TIMING CHARACTERISTICS](#).

HDQ serial communication is normally initiated by the host processor sending a break command to the bq34z110. A break is detected when the DATA pin is driven to a logic-low state for a time  $t_b$  or greater. The DATA pin should then be returned to its normal ready high logic state for a time  $t_{BR}$ . The bq34z110 is now ready to receive information from the host processor.

The bq34z110 is shipped in the I<sup>2</sup>C mode. TI provides tools to enable the HDQ peripheral.

### I<sup>2</sup>C INTERFACE

The gas gauge supports the standard I<sup>2</sup>C read, incremental read, one-byte write quick read, and functions. The 7-bit device address (ADDR) is the most significant 7 bits of the hex address and is fixed as 1010101. The 8-bit device address is therefore 0xAA or 0xAB for write or read, respectively.

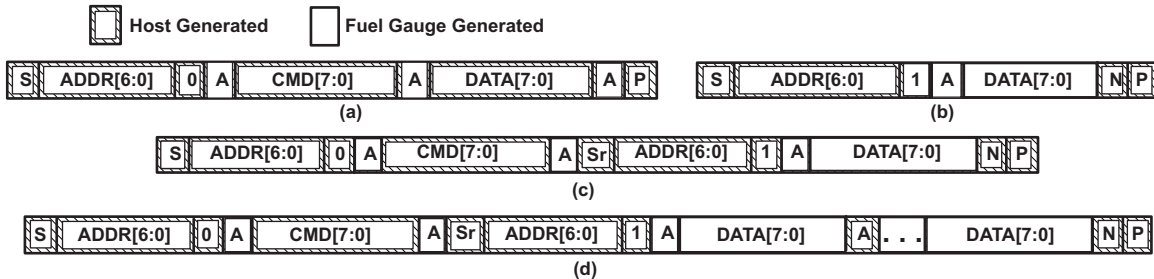

**Figure 6. Supported I<sup>2</sup>C formats: (a) 1-byte write, (b) quick read, (c) 1 byte-read, and (d) incremental read (S = Start, Sr = Repeated Start, A = Acknowledge, N = No Acknowledge, and P = Stop).**

The “quick read” returns data at the address indicated by the address pointer. The address pointer, a register internal to the I<sup>2</sup>C communication engine, increments whenever data is acknowledged by the bq34z110 or the I<sup>2</sup>C master. “Quick writes” function in the same manner and are a convenient means of sending multiple bytes to consecutive command locations (such as two-byte commands that require two bytes of data).

Attempt to write a read-only address (NACK after data sent by master):



Attempt to read an address above 0x7F (NACK command):



Attempt at incremental writes (NACK all extra data bytes sent):



Incremental read at the maximum allowed read address:

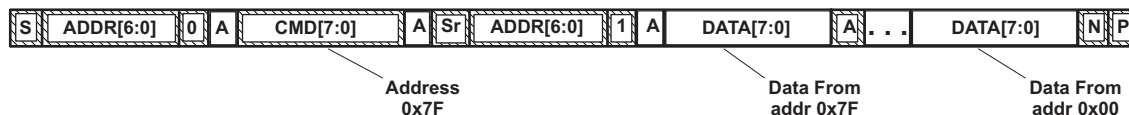

The I<sup>2</sup>C engine releases both SDA and SCL if the I<sup>2</sup>C bus is held low for t<sub>BUSERR</sub>. If the gas gauge was holding the lines, releasing them frees the master to drive the lines. If an external condition is holding either of the lines low, the I<sup>2</sup>C engine enters the low-power SLEEP mode.

## DESIGN STEPS

For additional design guidelines, see the *bq34z110EVM Wide Range Impedance Track Enabled Battery Fuel Gauge User's Guide* (SLUU904).

### STEP 1: Review and modify the Data Flash Configuration Data.

While many of the default parameters in the data flash will be suitable for most applications, the following should first be reviewed and modified to match the intended application.

- *Design Capacity*: Enter the value in mAh for the battery, even if you plan to treat your application from the “design energy” point of view.
- *Design Energy*: Enter the value in mWh.
- *Cell Charge Voltage Tx-Ty*: Enter the desired cell charge voltage for each JEITA temperature range.

### STEP 2: Review and modify the Data Flash Configuration Registers.

- *LED\_Comm Configuration*: See [Table 13](#) and [Table 14](#) to aid in selection of an LED mode. Note that the pin used for the optional Alert signal is dependent upon the LED mode selected.
- *Alert Configuration*: See [Table 15](#) to aid in selection of which faults will trigger the Alert pin.
- *Number of Series Cells*
- *Pack Configuration*: Ensure that the VOLSEL bit is set for multi-cell applications and cleared for single-cell applications.

### STEP 3: Design and Configure the Voltage Divider.

If the battery contains more than two series cells, a voltage divider network will be required. Design the divider network, based on the formula below. The voltage division required is from the highest expected battery voltage, down to approximately 900 mV. For example, using a lower leg resistor of 16.5 K $\Omega$  where the highest expected voltage is 32000 mV:

$$R_{series} = 16.5 \text{ K}\Omega (32000 \text{ mV} - 900 \text{ mV}) / 900 \text{ mV} = 570.2 \text{ K}\Omega$$

Based on price and availability, a 600 K resistor or pair of 300 K resistors could be used in the top leg along with a 16.5-K resistor in the bottom leg.

Set the *Voltage Divider* in the Data Flash Calibration section of the Evaluation Software to 32000 mV.

Use the Evaluation Software to calibrate to the applied nominal voltage, e.g.: 24000 mV. After calibration, a slightly different value will appear in the *Voltage Divider* parameter, which can be used as a default value for the project.

### STEP 4: Determine the Sense Resistor Value.

To ensure accurate current measurement, the input voltage generated across the current sense resistor should not exceed  $\pm 125$  mV. For applications having high dynamic range, it is allowable to extend this range to absolute maximum of  $\pm 300$  mV for overload conditions where a protector device will be taking independent protective action. In such an overloaded state, current reporting and gauging accuracy does not function correctly.

The value of the current sense resistor should be entered into both *CC Gain* and *CC Delta* parameters in the Data Flash Calibration section of the Evaluation Software.

### STEP 5: Review and Modify the Data Flash Gas Gauging Configuration, Data, and State.

- *Load Select*: See [Table 8](#) and [Table 9](#).
- *Load Mode*: See [Table 8](#) and [Table 9](#).
- *Cell Terminate Voltage*: This is the theoretical voltage where the system will begin to fail. It is defined as zero state of charge. Generally a more conservative level is used in order to have some reserve capacity. Note the value is for a single cell only.
- *Quit Current*: Generally should be set to a value slightly above the expected idle current of the system.
- *Qmax Cell 0*: Start with the C-rate value of your battery.

**STEP 6: Determine and Program the Chemical ID.**

Use the bqChem feature in the Evaluation Software to select and program the chemical ID matching your cell. If no match is found, use the procedure defined in TI's *Mathcad Chemistry Selection Tool (SLUC138)*.

**STEP 7: Calibrate.**

Follow the steps on the Calibration screen in the Evaluation Software. Achieving the best possible calibration is important before moving on to [STEP 8: Run an Optimization Cycle](#). For mass production, calibration is not required for single-cell applications. For multi-cell applications, only voltage calibration is required. Current and temperature may be calibrated to improve gauging accuracy if needed.

**STEP 8: Run an Optimization Cycle.**

1. Start with a fully charged and relaxed battery.
2. Temporarily Adjust the **Cell BL Set Volt Threshold** so as not to affect a full discharge.
3. Send the IT Enable command 0x21. The VOK and QEN flags should be set.
4. Discharge the battery at C/10 until the battery is empty.

**CAUTION**

It may be necessary to stop the load, check the rebound, then apply the load again to ensure that the rebounded voltage will not be significantly higher than the Cell Termination Voltage. For example, a Cell Termination Voltage of 1800 mV will be 10800 mV for a 12 V/six-cell battery. After stopping the load at 10500 mV, it can bounce all the way up to 11500 mV, which is too high for this procedure. However, if the load is continued until the battery voltage is 10000 mV, the resulting bounce back will be close to the intended termination voltage.

5. Allow the battery to relax. Wait for The OCV reading to be taken and the VOK flag to clear. The update status should now be set to 5.
6. Charge the battery until full. The VOK and QEN flags should be set during the charging operation.
7. Allow the battery to relax. The VOK flag will remain set.
8. Discharge the battery at C/10 until the battery is empty.
9. Allow the battery to relax. Wait for The OCV reading to be taken and the VOK flag to clear. The update status should now be set to 6.
10. Restore the **Cell BL Set Volt Threshold** to the desired value.

APPLICATION SCHEMATICS

2-Cell Lead-Acid and 5-LED Display

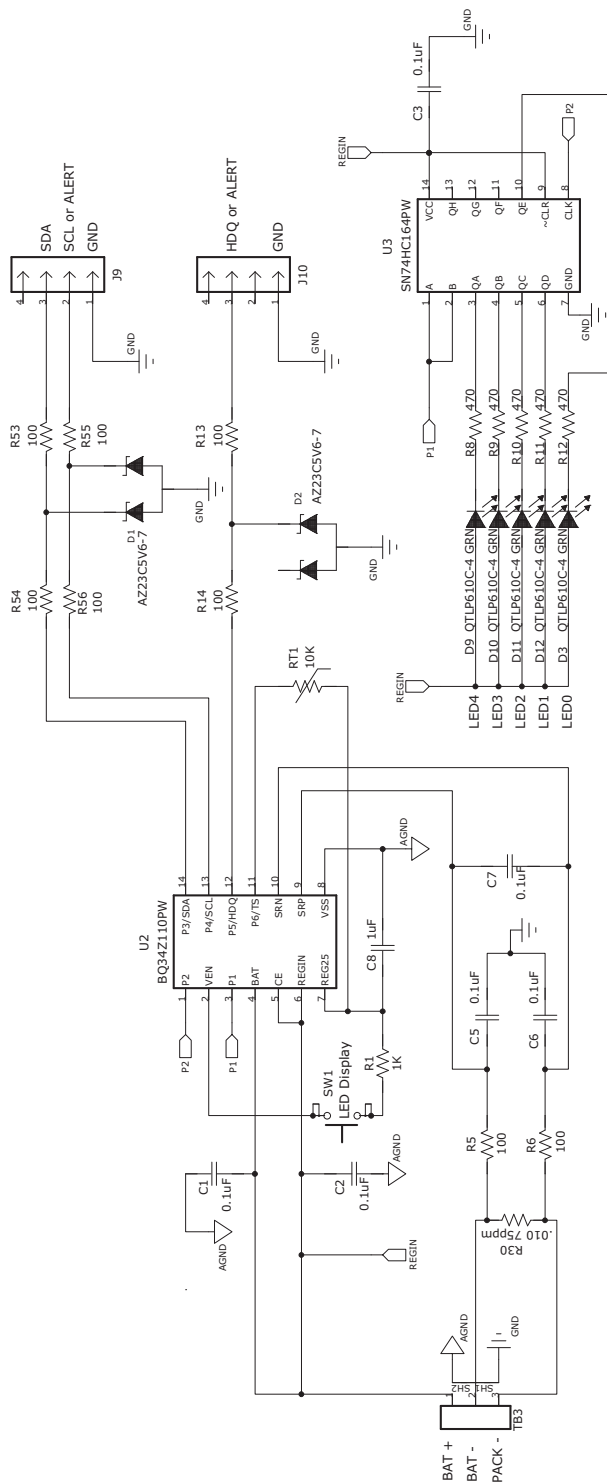
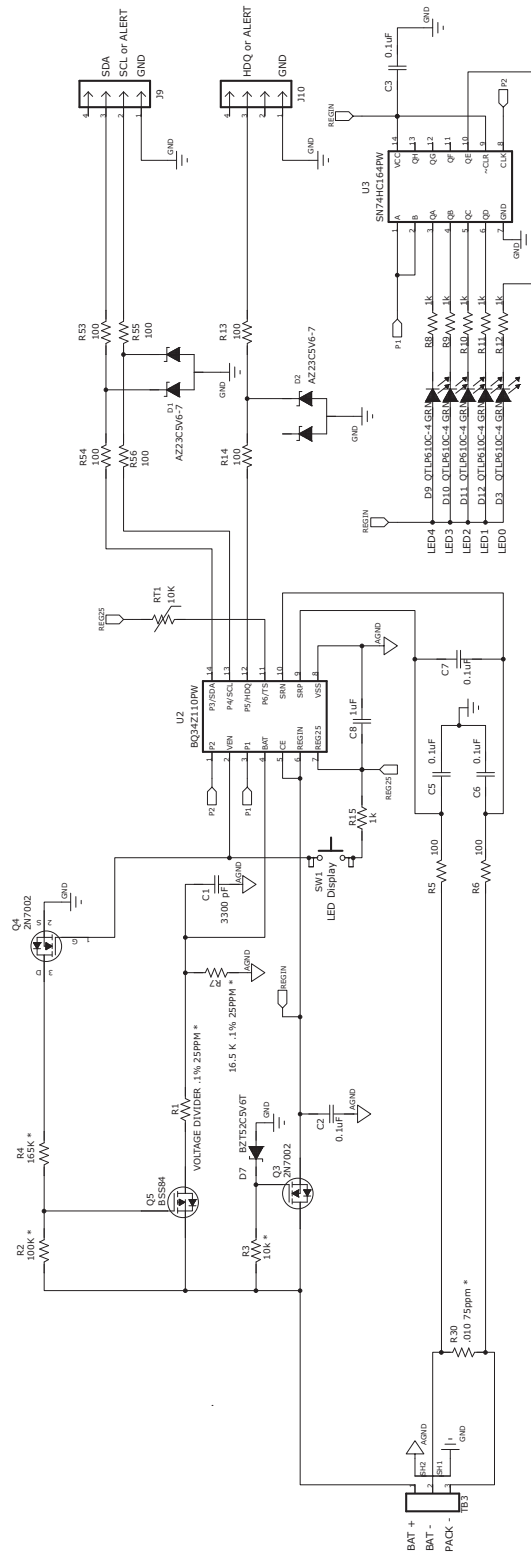

Figure 7. 2-Cell Lead-Acid and 5-LED Display

Multi-Cell and 5-LED Display



\* Optimize for required voltage and current

Figure 8. Multi-Cell and 5-LED Display

Full-Featured Evaluation Module EVM

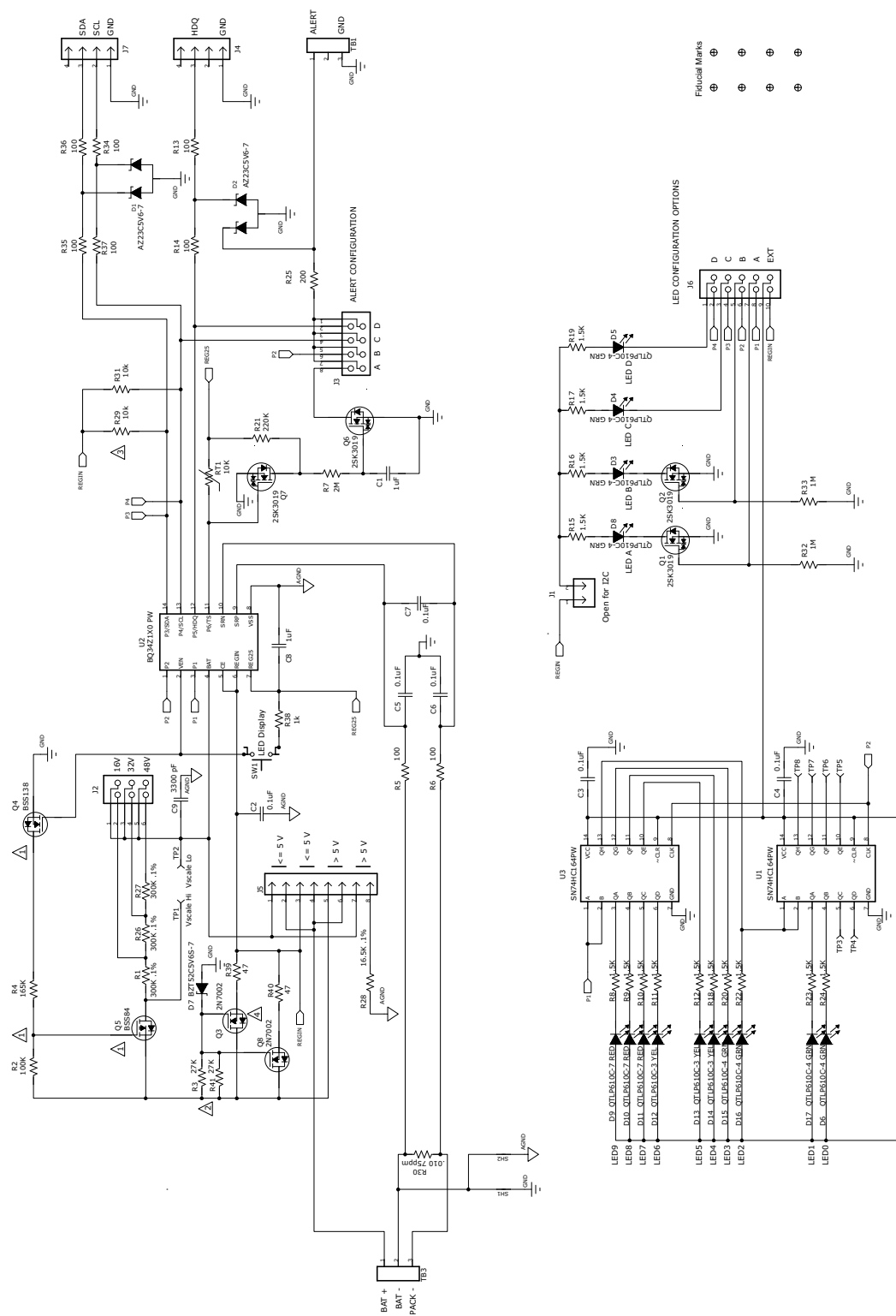

Figure 9. Full-Featured Evaluation Module EVM

- △ Optional for additional power saving
- △ Adjust for minimum current consumption in the application
- △ I2C pullups normally implemented in the host. Duplicated here since EV2300 does not provide
- △ Optimize for required LED power dissipation

## REFERENCE

### OPERATION CONFIGURATION B REGISTER

Some bq34z110 advanced features are rarely used. Operation Configuration registers B and C are available for configuring special applications. Default settings are recommended.

**Table 17. Operation Configuration B Bit Definition**

Bit 7	Bit 6	Bit 5	Bit 4	Bit 3	Bit 2	Bit 1	Bit 0
ChgDoDEoC	SE_TDD	VconsEN	SE_ISD	JEITA	LFPRelax	DoDWT	FConvEn

**ChgDoDEoC:** Enable DoD at EoC during charging only. True when set. Default is 1. Default setting is recommended.

**SE\_TDD:** Enable Tab Disconnection Detection. True when set. Default is 1.

**VconsEN:** Enable voltage consistency check. True when set. Default is 1. Default setting is recommended.

**SE\_ISD:** Enable Internal Short Detection. True when set. Default is 1.

**JEITA:** Enable JEITA charge current and voltage settings based on temperature. True when set. Default is 1. When not set, values in T2–T3 ranges for charge current and voltage are used regardless of temperature.

**LFPRelax:** Enable LiFePO4 long RELAXATION mode when chemical ID 400 series is selected. True when set. Default is 1.

**DoDWT:** Enable Dod weighting for LiFePO4 support when chemical ID 400 series is selected. True when set. Default is 1.

**FConvEn:** Enable fast convergence algorithm. Default is 1. Default setting is recommended.

### OPERATION CONFIGURATION C REGISTER

**Table 18. Operation Configuration C Bit Definition**

Bit 7	Bit 6	Bit 5	Bit 4	Bit 3	Bit 2	Bit 1	Bit 0
FastQmax	RsvdSBS	FF_Near_End	SleepWakeChg	RSVD	RSVD	RSVD	RSVD

**FastQmax:** Enable Fast Qmax Update mode. True when set. Default is 0. Default setting is recommended.

**RsvdSBS:** Enable to activate debug information in command space 0x6d ~ 0x76. For special use only. Default setting is recommended.

**FF\_Near\_End:** Enable to use a fast voltage filter near the end of discharge only. Default setting is recommended.

**SleepWakeChg:** Enable for faster sampling in SLEEP mode. Default setting is recommended.

**RSVD:** Reserved. Default is 0.

### EXTENDED DATA COMMANDS

Extended commands offer additional functionality beyond the standard set of commands. They are used in the same manner; however unlike standard commands, extended commands are not limited to 2-byte words. The number of command bytes for a given extended command ranges in size from single to multiple bytes, as specified in [Table 19](#). For details on the SEALED and UNSEALED states, refer to [ACCESS MODES](#).

**Table 19. Extended Commands**

NAME	COMMAND CODE	UNITS	SEALED ACCESS <sup>(1), (2)</sup>	UNSEALED ACCESS <sup>(1), (2)</sup>	
<i>AtRate()</i>	AR	0X10, 0x11	mA	R/W	R/W
<i>AtRateTimeToEmpty()</i>	ARTTE	0x12, 0x13	Minutes	R	R
<i>NominalAvailableCapacity()</i>	NAC	0x14, 0x15	mAh	R	R
<i>FullAvailableCapacity()</i>	FAC	0x16, 0x17	mAh	R	R
<i>TimeToEmpty()</i>	TTE	0x18, 0x19	Minutes	R	R
<i>TimeToFull()</i>	TTF	0x1a, 0x1b	Minutes	R	R
<i>StandbyCurrent()</i>	SI	0x1c, 0x1d	mA	R	R
<i>StandbyTimeToEmpty()</i>	STTE	0x1e, 0x1f	Minutes	R	R
<i>MaxLoadCurrent()</i>	MLI	0x20, 0x21	mA	R	R
<i>MaxLoadTimeToEmpty()</i>	MLTTE	0x22,0x23	Minutes	R	R
<i>AvailableEnergy()</i>	AE	0x24, 0x25	10 mWhr	R	R
<i>AveragePower()</i>	AP	0x26, 0x27	10 mW	R	R
<i>TTEatConstantPower()</i>	TTECP	0x28, 0x29	Minutes	R	R
<i>Internal_Temp()</i>	INTTEMP	0x2a, 0x2b	0.1°K	R	R
<i>CycleCount()</i>	CC	0x2c, 0x2d	Counts	R	R
<i>StateOfHealth()</i>	SOH	0x2e, 0x2f	% / num	R	R
<i>ChargeVoltage()</i>	CHGV	0x30, 0x31	mV	R	R
<i>ChargeCurrent()</i>	CHGI	0x32, 0x33	mA	R	R
<i>PassedCharge()</i>	PCHG	0x34, 0x35	mAh	R	R
<i>DOD0()</i>	DOD0	0x36, 0x37	HEX#	R	R
<i>SelfDischargeCurrent</i>	SDSG	0x38, 0x39	mA	R	R
<i>PackConfiguration()</i>	PKCFG	0x3a, 0x3b	N/A	R	R
<i>DesignCapacity()</i>	DCAP	0x3c, 0x3d	mAh	R	R
<i>DataFlashClass()</i> (2)	DFCLS	0x3e	N/A	N/A	R/W
<i>DataFlashBlock()</i> (2)	DFBLK	0x3f	N/A	R/W	R/W
<i>Authenticate()/BlockData()</i>	A/DF	0x40...0x53	N/A	R/W	R/W
<i>AuthenticateChecksum()/BlockData()</i>	ACKS/DFD	0x54	N/A	R/W	R/W
<i>BlockData()</i>	DFD	0x55...0x5f	N/A	R	R/W
<i>BlockDataChecksum()</i>	DFDCKS	0x60	N/A	R/W	R/W
<i>BlockDataControl()</i>	DFDCNTL	0x61	N/A	N/A	R/W
<i>DeviceNameLength()</i>	DNAMELEN	0x62	N/A	R	R
<i>DeviceName()</i>	DNAME	0x63...0x69	N/A	R	R
Reserved	RSVD	0x6a...0x7f	N/A	R	R

(1) SEALED and UNSEALED states are entered via commands to CNTL 0x00 and 0x01

(2) In SEALED mode, data flash *cannot* be accessed through commands 0x3e and 0x3f.

***AtRate()*: 0X10, 0x11**

The *AtRate()* read-/write-word function is the first half of a two-function call-set used to set the *AtRate* value used in calculations made by the *AtRateTimeToEmpty()* function. The *AtRate()* units are in mA.

The *AtRate()* value is a signed integer and both positive and negative values will be interpreted as a discharge current value. The *AtRateTimeToEmpty()* function returns the predicted operating time at the *AtRate* value of discharge. The default value for *AtRate()* is zero and will force *AtRate()* to return 65535.

***AtRateTimeToEmpty()*: 0x12, 0x13**

This read-word function returns an unsigned integer value of the predicted remaining operating time if the battery is discharged at the *AtRate()* value in minutes with a range of 0 to 65534. A value of 65535 indicates *AtRate()* = 0.

The gas gauge updates *AtRateTimeToEmpty()* within 1s after the host sets the *AtRate()* value. The gas gauge automatically updates *AtRateTimeToEmpty()* based on the *AtRate()* value every 1 s.

#### **NominalAvailableCapacity(): 0x14, 0x15**

This read-only command pair returns the uncompensated (no or light load) battery capacity remaining. Units are 1 mAh per bit.

#### **FullAvailableCapacity(): 0x16, 0x17**

This read-only command pair returns the uncompensated (no or light load) capacity of the battery when fully charged. Units are 1 mAh per bit. *FullAvailableCapacity()* is updated at regular intervals, as specified by the Impedance Track algorithm.

#### **TimeToEmpty(): 0x18, 0x19**

This read-only function returns an unsigned integer value of the predicted remaining battery life at the present rate of discharge, in minutes. A value of 65535 indicates battery is not being discharged.

#### **TimeToFull(): 0x1a, 0x1b**

This read-only function returns an unsigned integer value of predicted remaining time until the battery reaches full charge, in minutes, based upon *AverageCurrent()*. The computation should account for the taper current time extension from the linear TTF computation based on a fixed *AverageCurrent()* rate of charge accumulation. A value of 65535 indicates the battery is not being charged.

#### **StandbyCurrent(): 0x1c, 0x1d**

This read-only function returns a signed integer value of the measured standby current through the sense resistor. The *StandbyCurrent()* is an adaptive measurement. Initially it reports the standby current programmed in Initial Standby, and after spending some time in standby, reports the measured standby current.

The register value is updated every 1 second when the measured current is above the Deadband (3 mA default) and is less than or equal to 2 x Initial Standby. The first and last values that meet this criterion should not be averaged in, since they may not be stable values. To approximate a 1 minute time constant, each new *StandbyCurrent()* value is computed as follows:

$$StandbyCurrent()_{NEW} = (239/256) \times StandbyCurrent()_{OLD} + (17/256) \times AverageCurrent()$$

#### **StandbyTimeToEmpty(): 0x1e, 0x1f**

This read-only function returns an unsigned integer value of the predicted remaining battery life at the standby rate of discharge, in minutes. The computation should use Nominal Available Capacity (NAC), the uncompensated remaining capacity, for this computation. A value of 65535 indicates battery is not being discharged.

#### **MaxLoadCurrent(): 0x20, 0x21**

This read-only function returns a signed integer value, in units of mA, of the maximum load conditions. The *MaxLoadCurrent()* is an adaptive measurement which is initially it reports the maximum load current programmed in Initial Max Load Current. If the measured current is ever greater than Initial Max Load Current, then *MaxLoadCurrent()* updates to the new current. *MaxLoadCurrent()* is reduced to the average of the previous value and Initial Max Load Current whenever the battery is charged to full after a previous discharge to an SOC less than 50%. This prevents the reported value from maintaining an unusually high value.

#### **MaxLoadTimeToEmpty(): 0x22, 0x23**

This read-only function returns an unsigned integer value of the predicted remaining battery life at the maximum load current discharge rate, in minutes. A value of 65535 indicates that the battery is not being discharged.

#### **AvailableEnergy(): 0x24, 0x25**

This read-only function returns an unsigned integer value of the predicted charge or energy remaining in the battery. The value is reported in units of mWh.

**AveragePower(): 0x26, 0x27**

This read-word function returns an unsigned integer value of the average power of the current discharge. A value of 0 indicates that the battery is not being discharged. The value is reported in units of mW.

**TimeToEmptyAtConstantPower(): 0x28, 0x29**

This read-only function returns an unsigned integer value of the predicted remaining operating time if the battery is discharged at the *AveragePower()* value in minutes. A value of 65535 indicates *AveragePower()* = 0. The gas gauge automatically updates *TimeToEmptyatContantPower()* based on the *AveragePower()* value every 1 s.

**InternalTemp(): 0x2a, 0x2b**

This read-only function returns an unsigned integer value of the measured internal temperature of the device in units of 0.1°K measured by the fuel gauge.

**CycleCount(): 0x2c, 0x2d**

This read-only function returns an unsigned integer value of the number of cycles the battery has experienced with a range of 0 to 65535. One cycle occurs when accumulated discharge  $\geq$  *CC Threshold*.

**StateOfHealth(): 0x2e, 0x2f**

This read-only function returns an unsigned integer value, expressed as a percentage of the ratio of predicted FCC(25°C, SOH current rate) over the *DesignCapacity()*. The FCC(25°C, SOH current rate) is the calculated full charge capacity at 25°C and the SOH current rate which is specified in the data flash (State of Health Load). The range of the returned SOH percentage is 0x00 to 0x64, indicating 0% to 100% correspondingly.

**ChargeVoltage(): 0x30, 0x31**

This unsigned integer indicates the recommended charging voltage.

**ChargeCurrent(): 0x32, 0x33**

This signed integer indicates the recommended charging current.

**PassedCharge(): 0x34, 0x35**

This signed integer indicates the amount of charge passed through the sense resistor since the last IT simulation in mAh.

**DOD0(): 0x36, 0x37**

This unsigned integer indicates the depth of discharge during the most recent OCV reading.

**SelfDischargeCurrent(): 0x38, 0x39**

This read-only command pair returns a signed integer value that estimates the battery self discharge current.

**PackConfiguration(): 0x3a, 0x3b**

This Read-Word function allows the host to read the configuration of selected features of the bq34z110 pertaining to various features. Refer to [PACK CONFIGURATION REGISTER](#).

**DesignCapacity(): 0x3c, 0x3d**

SEALED and UNSEALED Access: This command returns theoretical or nominal capacity of a new pack. The value is stored in *Design Capacity* and is expressed in mAh.

**DataFlashClass(): 0x3e**

UNSEALED Access: This command sets the data flash class to be accessed. The class to be accessed should be entered in hexadecimal.

SEALED Access: This command is not available in SEALED mode.

**DataFlashBlock(): 0x3f**

UNSEALED Access: If BlockDataControl has been set to 0x00, this command directs which data flash block will be accessed by the *BlockData()* command. Writing a 0x00 to *DataFlashBlock()* specifies the *BlockData()* command transfers authentication data. Issuing a 0x01 instructs the *BlockData()* command to transfer Manufacturer Data.

SEALED Access: This command directs which data flash block will be accessed by the *BlockData()* command. Writing a 0x00 to *DataFlashBlock()* specifies the *BlockData()* command transfers authentication data. Issuing a 0x01 instructs the *BlockData()* command to transfer **Manufacturer Data**.

**AuthenticateData/BlockData(): 0x40...0x53**

UNSEALED Access: This data block has a dual function. It is used for the authentication challenge and response and is part of the 32-byte data block when accessing data flash.

SEALED Access: This data block is used for authentication challenge and response and is part of the 32-byte data block when accessing the **Manufacturer Data**.

**AuthenticateChecksum/BlockData(): 0x54**

UNSEALED Access: This byte holds the authenticate checksum when writing the authentication challenge to the bq34z110 and is part of the 32-byte data block when accessing data flash.

SEALED Access: This byte holds the authentication checksum when writing the authentication challenge to the bq34z110 and is part of the 32-byte data block when accessing **Manufacturer Data**.

**BlockData(): 0x55...0x5f**

UNSEALED Access: This data block is the remainder of the 32-byte data block when accessing data flash.

SEALED Access: This data block is the remainder of the 32-byte data block when accessing **Manufacturer Data**.

**BlockDataChecksum(): 0x60**

UNSEALED Access: This byte contains the checksum on the 32 bytes of block data read or written to data flash.

SEALED Access: This byte contains the checksum for the 32 bytes of block data written to **Manufacturer Data**.

**BlockDataControl(): 0x61**

UNSEALED Access: This command is used to control data flash access mode. Writing 0x00 to this command enables *BlockData()* to access general data flash. Writing a 0x01 to this command enables SEALED mode operation of *DataFlashBlock()*.

**DeviceNameLength(): 0x62**

UNSEALED and SEALED Access: This byte contains the length of the **Device Name**.

**DeviceName(): 0x63...0x6A**

UNSEALED and SEALED Access: This block contains the device name that is programmed in **Device Name**.

## DATA FLASH SUMMARY

Table 20 summarizes the data flash locations available to the user, including their default, minimum, and maximum values.

**Table 20. Data Flash Summary**

Class	Subclass ID	Subclass	Offset	Name	Data Type	Min Value	Max Value	Default Value	Units
Configuration	2	Safety	0	OT Chg	I2	0	1200	550	0.1°C
Configuration	2	Safety	2	OT Chg Time	U1	0	60	2	s
Configuration	2	Safety	3	OT Chg Recovery	I2	0	1200	500	0.1°C
Configuration	2	Safety	5	OT Dsg	I2	0	1200	600	0.1°C
Configuration	2	Safety	7	OT Dsg Time	U1	0	60	2	s
Configuration	2	Safety	8	OT Dsg Recovery	I2	0	1200	550	0.1°C
Configuration	32	Charge Inhibit Cfg	0	Chg Inhibit Temp Low	I2	-400	1200	0	0.1°C
Configuration	32	Charge Inhibit Cfg	2	Chg Inhibit Temp High	I2	-400	1200	450	0.1°C
Configuration	32	Charge Inhibit Cfg	4	Temp Hys	I2	0	100	50	0.1°C
Configuration	34	Charge	0	Suspend Low Temp	I2	-400	1200	-50	0.1°C
Configuration	34	Charge	2	Suspend High Temp	I2	-400	1200	550	0.1°C
Configuration	34	Charge	4	Chg Eff	U1	0	100	100	%
Configuration	34	Charge	5	Chg Eff Temp Comp	U1	0	255	25	%/100
Configuration	34	Charge	6	Chg Eff Drop Off	U1	0	100	96	%
Configuration	34	Charge	7	Chg Eff Reduction rate	U1	0	100	10	%/10
Configuration	34	Charge	8	Maintenance Current	U1	0	100	0	%
Configuration	36	Charge Termination	0	Taper Current	I2	0	1000	100	mA
Configuration	36	Charge Termination	2	Min Taper Capacity	I2	0	1000	25	0.01 mAh
Configuration	36	Charge Termination	4	Cell Taper Voltage	I2	0	1000	100	mV
Configuration	36	Charge Termination	6	Current Taper Window	U1	0	60	40	s
Configuration	36	Charge Termination	7	TCA Set %	I1	-1	100	99	%
Configuration	36	Charge Termination	8	TCA Clear %	I1	-1	100	95	%
Configuration	36	Charge Termination	9	FC Set %	I1	-1	100	100	%
Configuration	36	Charge Termination	10	FC Clear %	I1	-1	100	98	%
Configuration	36	Charge Termination	11	DODatEOC Delta T	I2	0	1000	100	0.1°C
Configuration	48	Data	0	Rem Cap Alarm	I2	0	700	100	mAh
Configuration	48	Data	6	Cell Design Voltage	I2	2000	5000	2000	mV
Configuration	48	Data	8	Initial Standby	I1	-256	0	-10	mA
Configuration	48	Data	9	Initial MaxLoad	I2	-32767	0	-500	mA
Configuration	48	Data	13	Manufacture Date	U2	0	65535	0	Date code
Configuration	48	Data	15	Serial Number	H2	0000	ffff	1	num
Configuration	48	Data	17	Cycle Count	U2	0	65535	0	Count
Configuration	48	Data	19	CC Threshold	I2	100	32767	900	mAh
Configuration	48	Data	21	Design Capacity	I2	0	32767	4000	mAh
Configuration	48	Data	23	Design Energy	I2	0	32767	8000	mWh/cWh
Configuration	48	Data	25	SOH Load Current	I2	-32767	0	-400	mA
Configuration	48	Data	27	TDD SOH Percent	I1	0	100	90	%
Configuration	48	Data	28	Cell Charge Voltage T1-T2	U2	0	4600	2200	mV
Configuration	48	Data	30	Cell Charge Voltage T2-T3	U2	0	4600	2450	mV
Configuration	48	Data	32	Cell Charge Voltage T3-T4	U2	0	4600	2350	mV
Configuration	48	Data	34	Charge Current T1-T2	U1	0	100	10	% of des cap
Configuration	48	Data	35	Charge Current T2-T3	U1	0	100	50	% of des cap
Configuration	48	Data	36	Charge Current T3-T4	U1	0	100	30	% of des cap

**Table 20. Data Flash Summary (continued)**

Class	Subclass ID	Subclass	Offset	Name	Data Type	Min Value	Max Value	Default Value	Units
Configuration	48	Data	37	JEITA T1	I1	-128	127	0	°C
Configuration	48	Data	38	JEITA T2	I1	-128	127	10	°C
Configuration	48	Data	39	JEITA T3	I1	-128	127	45	°C
Configuration	48	Data	40	JEITA T4	I1	-128	127	55	°C
Configuration	48	Data	41	ISD Current	I2	0	32767	10	HourRate
Configuration	48	Data	43	ISD Current Filter	U1	0	255	127	—
Configuration	48	Data	44	Min ISD Time	U1	0	255	7	Hour
Configuration	48	Data	45	Design Energy Scale	U1	1	10	1	1 or 10 only
Configuration	48	Data	46	Device Name	S9	x	x	bq34z110	—
Configuration	48	Data	55	Manufacturer Name	S12	x	x	Texas Inst.	—
Configuration	48	Data	67	Device Chemistry	S5	x	x	PbA	—
Configuration	49	Discharge	0	SOC1 Set Threshold	U2	0	65535	150	mAh
Configuration	49	Discharge	2	SOC1 Clear Threshold	U2	0	65535	175	mAh
Configuration	49	Discharge	4	SOCF Set Threshold	U2	0	65535	75	mAh
Configuration	49	Discharge	6	SOCF Clear Threshold	U2	0	65535	100	mAh
Configuration	49	Discharge	9	Cell BL Set Volt Threshold	I2	0	5000	1850	mV
Configuration	49	Discharge	11	Cell BL Set Volt Time	U1	0	60	2	s
Configuration	49	Discharge	12	Cell BL Clear Volt Threshold	I2	0	5000	1950	mV
Configuration	49	Discharge	14	Cell BH Set Volt Threshold	I2	0	5000	2450	mV
Configuration	49	Discharge	16	Cell BH Set Volt Time	U1	0	60	2	s
Configuration	49	Discharge	17	Cell BH Clear Volt Threshold	I2	0	5000	2400	mV
Configuration	56	Manufacturer Data	0	Pack Lot Code	H2	0	0xFFFF	0000	—
Configuration	56	Manufacturer Data	2	PCB Lot Code	H2	0	0xFFFF	0000	—
Configuration	56	Manufacturer Data	4	Firmware Version	H2	0	0xFFFF	0000	—
Configuration	56	Manufacturer Data	6	Hardware Revision	H2	0	0xFFFF	0	—
Configuration	56	Manufacturer Data	8	Cell Revision	H2	0	0xFFFF	0	—
Configuration	56	Manufacturer Data	10	DF Config Version	H2	0	0xFFFF	0	—
Configuration	57	Integrity Data	6	Static Chem DF Checksum	H2	00x7fff	0x75F2	0	—
Configuration	59	Lifetime Data	0	Lifetime Max Temp	I2	0	1400	300	0.1°C
Configuration	59	Lifetime Data	2	Lifetime Min Temp	I2	-600	1400	200	0.1°C
Configuration	59	Lifetime Data	4	Lifetime Max Chg Current	I2	-32767	32767	0	mA
Configuration	59	Lifetime Data	6	Lifetime Max Dsg Current	I2	-32767	32767	0	mA
Configuration	59	Lifetime Data	8	Lifetime Max Pack Voltage	I2	0	32767	1500	mV
Configuration	59	Lifetime Data	10	Lifetime Min Pack Voltage	I2	0	32767	2500	mV
Configuration	60	Lifetime Temp Samples	0	Lifetime Flash Count	U2	0	65535	0	—
Configuration	64	Registers	0	Pack Configuration	H2	0	0xFFFF	0x0961	—
Configuration	64	Registers	2	Pack Configuration B	H1	0	0xFF	0xFF	Flgs
Configuration	64	Registers	3	Pack Configuration C	H1	0	0xFF	0x30	Flgs
Configuration	64	Registers	4	LED_Comm Configuration	H1	0	0xFF	0x00	Flgs
Configuration	64	Registers	5	Alert Configuration	H2	0	0xFFFF	0x0000	Flgs
Configuration	64	Registers	7	Number of Series Cells	U1	1	100	6	—
Configuration	66	Lifetime Resolution	3	LT Update Time	U2	0	65535	60	s
Configuration	67	LED Display	0	LED Hold Time	U1	0	255	4	s
Configuration	68	Power	0	Flash Update OK Voltage Cell Volt	I2	0	4200	2800	mV
Configuration	68	Power	2	Sleep Current	I2	0	100	10	mA
Configuration	68	Power	11	Full Sleep Wait Time	U1	0	255	0	s
System Data	58	Manufacturer Info	0-31	Manufacturer Info Block 0-31	H1	0	FF	00	—

**Table 20. Data Flash Summary (continued)**

Class	Subclass ID	Subclass	Offset	Name	Data Type	Min Value	Max Value	Default Value	Units
Gas Gauging	80	IT Cfg	0	Load Select	U1	0	255	1	—
Gas Gauging	80	IT Cfg	1	Load Mode	U1	0	255	0	—
Gas Gauging	80	IT Cfg	21	Max Res Factor	U1	0	255	15	num
Gas Gauging	80	IT Cfg	22	Min Res Factor	U1	0	255	3	num
Gas Gauging	80	IT Cfg	25	Ra Filter	U2	0	1000	500	—
Gas Gauging	80	IT Cfg	42	Fast Qmax Start DOD %	U1	0	255	92	%
Gas Gauging	80	IT Cfg	43	Fast Qmax End DOD %	U1	0	255	96	%
Gas Gauging	80	IT Cfg	44	Fast Qmax Start Volt Delta	I2	0	4200	100	mV
Gas Gauging	80	IT Cfg	67	Cell Termination Voltage	I2	2500	3700	1800	mV
Gas Gauging	80	IT Cfg	69	Cell Termination Voltage Delta	I2	0	4200	25	mV
Gas Gauging	80	IT Cfg	72	Simulation Res Relax Time	U2	0	65534	200	s
Gas Gauging	80	IT Cfg	76	User Rate-mA	I2	-32767	32767	0	mA
Gas Gauging	80	IT Cfg	78	User Rate-mW/cW	I2	-32767	32767	0	mW/cW
Gas Gauging	80	IT Cfg	80	Reserve Cap-mAh	I2	0	9000	0	mAh
Gas Gauging	80	IT Cfg	82	Reserve Energy	I2	0	14000	0	mWh/cWh
Gas Gauging	80	IT Cfg	86	Max Scale Back Grid	U1	0	15	4	—
Gas Gauging	80	IT Cfg	87	Cell Max Delta V	U2	0	65535	100	mV
Gas Gauging	80	IT Cfg	89	Cell Min Delta V	U2	0	65535	0	mV
Gas Gauging	80	IT Cfg	91	Max Sim Rate	U1	0	255	2	C/rate
Gas Gauging	80	IT Cfg	92	Min Sim Rate	U1	0	255	20	C/rate
Gas Gauging	80	IT Cfg	93	Ra Max Delta	U2	0	32767	44	mΩ
Gas Gauging	80	IT Cfg	95	Qmax Max Delta %	U1	0	100	5	mAh
Gas Gauging	80	IT Cfg	96	Cell DeltaV Max Delta	U2	0	65535	10	mV
Gas Gauging	80	IT Cfg	102	Fast Scale Start SOC	U1	0	100	10	%
Gas Gauging	80	IT Cfg	107	Charge Hys Voltage Shift	I2	0	2000	40	mV
Gas Gauging	81	Current Thresholds	0	Dsg Current Threshold	I2	0	2000	60	mA
Gas Gauging	81	Current Thresholds	2	Chg Current Threshold	I2	0	2000	75	mA
Gas Gauging	81	Current Thresholds	4	Quit Current	I2	0	1000	40	mA
Gas Gauging	81	Current Thresholds	6	Dsg Relax Time	U2	0	8191	60	s
Gas Gauging	81	Current Thresholds	8	Chg Relax Time	U1	0	255	60	s
Gas Gauging	81	Current Thresholds	9	Quit Relax Time	U1	0	63	1	s
Gas Gauging	81	Current Thresholds	10	Max IR Correct	U2	0	1000	400	mV
Gas Gauging	82	State	0	Qmax Cell 0	I2	0	32767	4000	mAh
Gas Gauging	82	State	2	Cycle Count	U2	0	65535	0	—
Gas Gauging	82	State	4	Update Status	H1	0x00	0x06	0x00	—
Gas Gauging	82	State	5	Cell V at Chg Term	I2	0	5000	2400	mV
Gas Gauging	82	State	7	Avg I Last Run	I2	-32768	32767	-299	mA
Gas Gauging	82	State	9	Avg P Last Run	I2	-32768	32767	-1131	mW/cW
Gas Gauging	82	State	11	Cell Delta Voltage	I2	-32768	32767	2	mV
Gas Gauging	82	State	15	T Rise	I2	0	32767	0	—
Gas Gauging	82	State	17	T Time Constant	I2	0	32767	32767	—
OCV Table	83	OCV Table	0	Chem ID	H2	0	0xFFFF	0107	—
Ra Tables	88	Data	0-31	Cell0 R_a Table	See Note 1				
Ra Tables	89	Data	0-31	xCell0 R_a Table	See Note 1				
Calibration	104	Data	0	CC Gain (Note 4)	F4	1.00E-01	4.00E+01	0.47095	num
Calibration	104	Data	4	CC Delta (Note 4)	F4	2.98E+04	1.19E+06	5.595e5	num
Calibration	104	Data	8	CC Offset (Note 4)	I2	-32768	32767	-1200	num
Calibration	104	Data	10	Board Offset (Note 4)	I1	-128	127	0	num

**Table 20. Data Flash Summary (continued)**

Class	Subclass ID	Subclass	Offset	Name	Data Type	Min Value	Max Value	Default Value	Units
Calibration	104	Data	11	Int Temp Offset	I1	-128	127	0	0.1°C
Calibration	104	Data	12	Ext Temp Offset	I1	-128	127	0	0.1°C
Calibration	104	Data	13	Pack V Offset	I1	-128	127	0	mV
Calibration	104	Data	14	Voltage Divider	U2	0	65535	20000	mV
Calibration	107	Current	1	Deadband	U1	0	255	5	mA
Security	112	Codes	0	Sealed to Unsealed	H4	0	ffffff	36720414	—
Security	112	Codes	4	Unsealed to Full	H4	0	ffffff	ffffff	—
Security	112	Codes	8	Authen Key3	H4	0	ffffff	01234567	—
Security	112	Codes	12	Authen Key2	H4	0	ffffff	89ABCDEF	—
Security	112	Codes	16	Authen Key1	H4	0	ffffff	FEDCBA98	—
Security	112	Codes	20	Authen Key0	H4	0	ffffff	76543210	—
1. Encoded battery profile information created by bqEasy software.									
2. Part number and/or part specific									
3. Not IEEE floating point									
4. Display as data flash value; value displayed in EVSW is different. See Table 21 for the conversion table.									

**Table 21. Data Flash (DF) to EVSW Conversion**

Class	Subclass ID	Subclass	Offset	Name	Data Type	Data Flash Default	Data Flash Unit	EVSW Default	EVSW Unit	DF to EVSW Conversion
Data	48	Data	13	Manufacture Date	U2	0	code	1-Jan-1980		Day+Mo*32+(Yr-1980)*256
Gas Gauging	80	IT Cfg	59	User Rate mW	I2	0	cW	0	mW	DF x 10
Gas Gauging	80	IT Cfg	63	Reserve Cap mWh	I2	0	cWh	0	mWh	DF x 10
Calibration	104	Data	0	CC Gain	F4	0.47095	Num	10.124	mΩ	4.768/DF
Calibration	104	Data	4	CC Delta	F4	5.595e5	Num	10.147	mΩ	5677445/DF
Calibration	104	Data	8	CC Offset	I2	-1200	Num	-0.576	mV	DF x 0.00048
Calibration	104	Data	10	Board Offset	I1	0	Num	0	μV	DF x 16/0.48

## REVISION HISTORY

Changes from Original (June 2012) to Revision A	Page
• 在总说明部分添加了额外信息 .....	1
• Changed 一个字 ( 编辑 ) .....	1
• Changed 文档至生产数据 .....	1
• Changed the Typical Implementation graphic .....	3
• Changed SLEEP Mode section .....	23
• Changed FULLSLEEP Mode section .....	23
• Changed figure .....	33
• Changed Data Flash Summary .....	39

**PACKAGING INFORMATION**

Orderable Device	Status (1)	Package Type	Package Drawing	Pins	Package Qty	Eco Plan (2)	Lead finish/ Ball material (6)	MSL Peak Temp (3)	Op Temp (°C)	Device Marking (4/5)	Samples
BQ34Z110PW	ACTIVE	TSSOP	PW	14	90	RoHS & Green	NIPDAU	Level-2-260C-1 YEAR	-40 to 85	34Z110	<a href="#">Samples</a>
BQ34Z110PWR	ACTIVE	TSSOP	PW	14	2000	RoHS & Green	NIPDAU	Level-2-260C-1 YEAR	-40 to 85	34Z110	<a href="#">Samples</a>

(1) The marketing status values are defined as follows:

**ACTIVE:** Product device recommended for new designs.

**LIFEBUY:** TI has announced that the device will be discontinued, and a lifetime-buy period is in effect.

**NRND:** Not recommended for new designs. Device is in production to support existing customers, but TI does not recommend using this part in a new design.

**PREVIEW:** Device has been announced but is not in production. Samples may or may not be available.

**OBSOLETE:** TI has discontinued the production of the device.

(2) **RoHS:** TI defines "RoHS" to mean semiconductor products that are compliant with the current EU RoHS requirements for all 10 RoHS substances, including the requirement that RoHS substance do not exceed 0.1% by weight in homogeneous materials. Where designed to be soldered at high temperatures, "RoHS" products are suitable for use in specified lead-free processes. TI may reference these types of products as "Pb-Free".

**RoHS Exempt:** TI defines "RoHS Exempt" to mean products that contain lead but are compliant with EU RoHS pursuant to a specific EU RoHS exemption.

**Green:** TI defines "Green" to mean the content of Chlorine (Cl) and Bromine (Br) based flame retardants meet JS709B low halogen requirements of <=1000ppm threshold. Antimony trioxide based flame retardants must also meet the <=1000ppm threshold requirement.

(3) MSL, Peak Temp. - The Moisture Sensitivity Level rating according to the JEDEC industry standard classifications, and peak solder temperature.

(4) There may be additional marking, which relates to the logo, the lot trace code information, or the environmental category on the device.

(5) Multiple Device Markings will be inside parentheses. Only one Device Marking contained in parentheses and separated by a "~" will appear on a device. If a line is indented then it is a continuation of the previous line and the two combined represent the entire Device Marking for that device.

(6) Lead finish/Ball material - Orderable Devices may have multiple material finish options. Finish options are separated by a vertical ruled line. Lead finish/Ball material values may wrap to two lines if the finish value exceeds the maximum column width.

**Important Information and Disclaimer:**The information provided on this page represents TI's knowledge and belief as of the date that it is provided. TI bases its knowledge and belief on information provided by third parties, and makes no representation or warranty as to the accuracy of such information. Efforts are underway to better integrate information from third parties. TI has taken and continues to take reasonable steps to provide representative and accurate information but may not have conducted destructive testing or chemical analysis on incoming materials and chemicals. TI and TI suppliers consider certain information to be proprietary, and thus CAS numbers and other limited information may not be available for release.

In no event shall TI's liability arising out of such information exceed the total purchase price of the TI part(s) at issue in this document sold by TI to Customer on an annual basis.

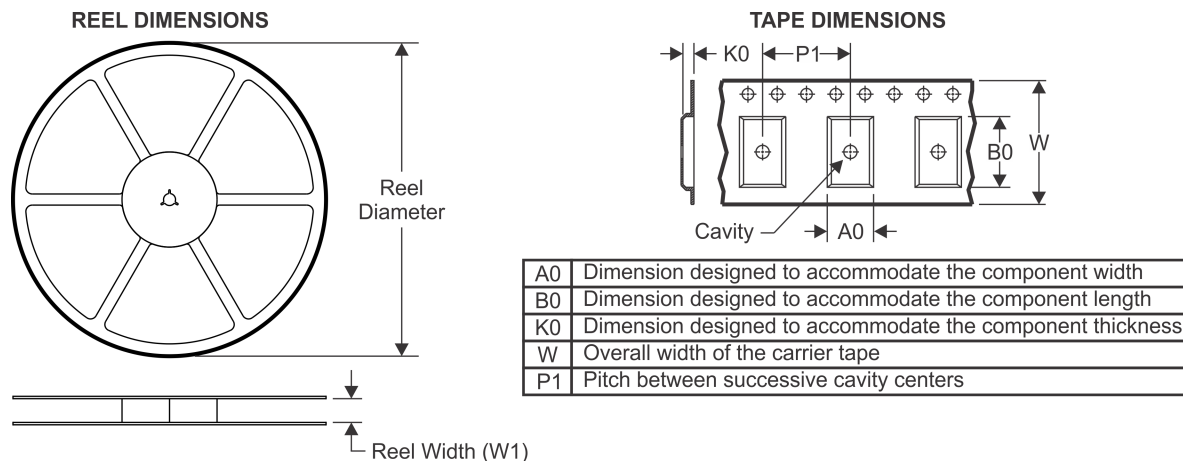
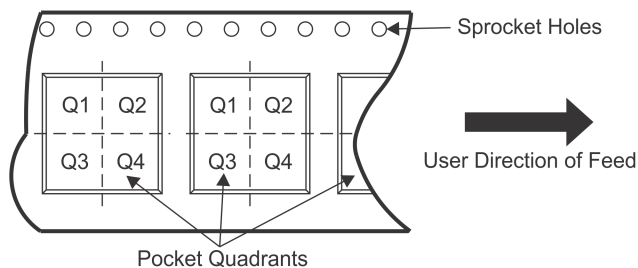

**TAPE AND REEL INFORMATION**

**QUADRANT ASSIGNMENTS FOR PIN 1 ORIENTATION IN TAPE**

\*All dimensions are nominal

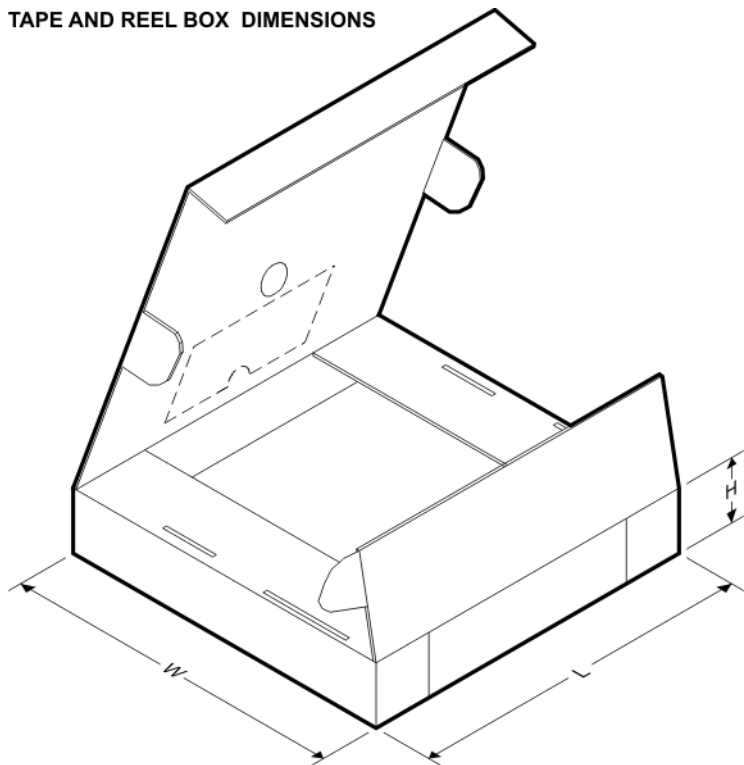
Device	Package Type	Package Drawing	Pins	SPQ	Reel Diameter (mm)	Reel Width W1 (mm)	A0 (mm)	B0 (mm)	K0 (mm)	P1 (mm)	W (mm)	Pin1 Quadrant
BQ34Z110PWR	TSSOP	PW	14	2000	330.0	12.4	6.9	5.6	1.6	8.0	12.0	Q1

**TAPE AND REEL BOX DIMENSIONS**

\*All dimensions are nominal

Device	Package Type	Package Drawing	Pins	SPQ	Length (mm)	Width (mm)	Height (mm)
BQ34Z110PWR	TSSOP	PW	14	2000	367.0	367.0	38.0

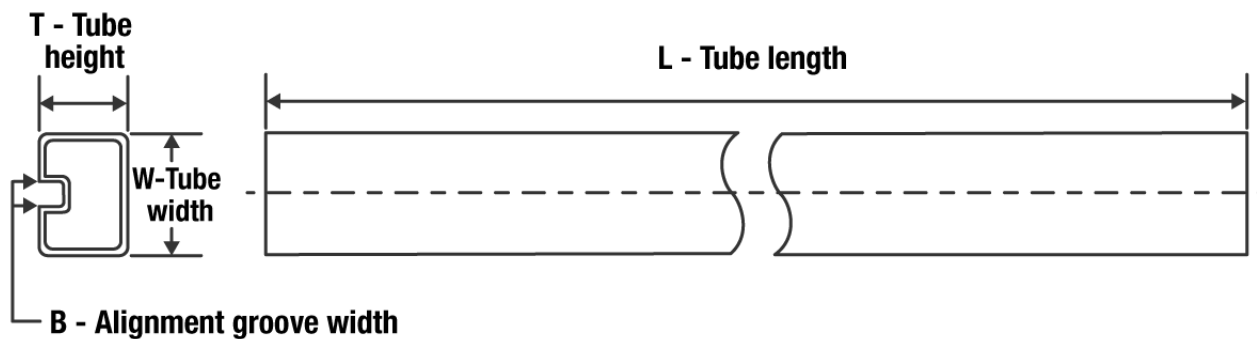
**TUBE**

\*All dimensions are nominal

Device	Package Name	Package Type	Pins	SPQ	L (mm)	W (mm)	T (μm)	B (mm)
BQ34Z110PW	PW	TSSOP	14	90	530	10.2	3600	3.5

PW (R-PDSO-G14)

PLASTIC SMALL OUTLINE

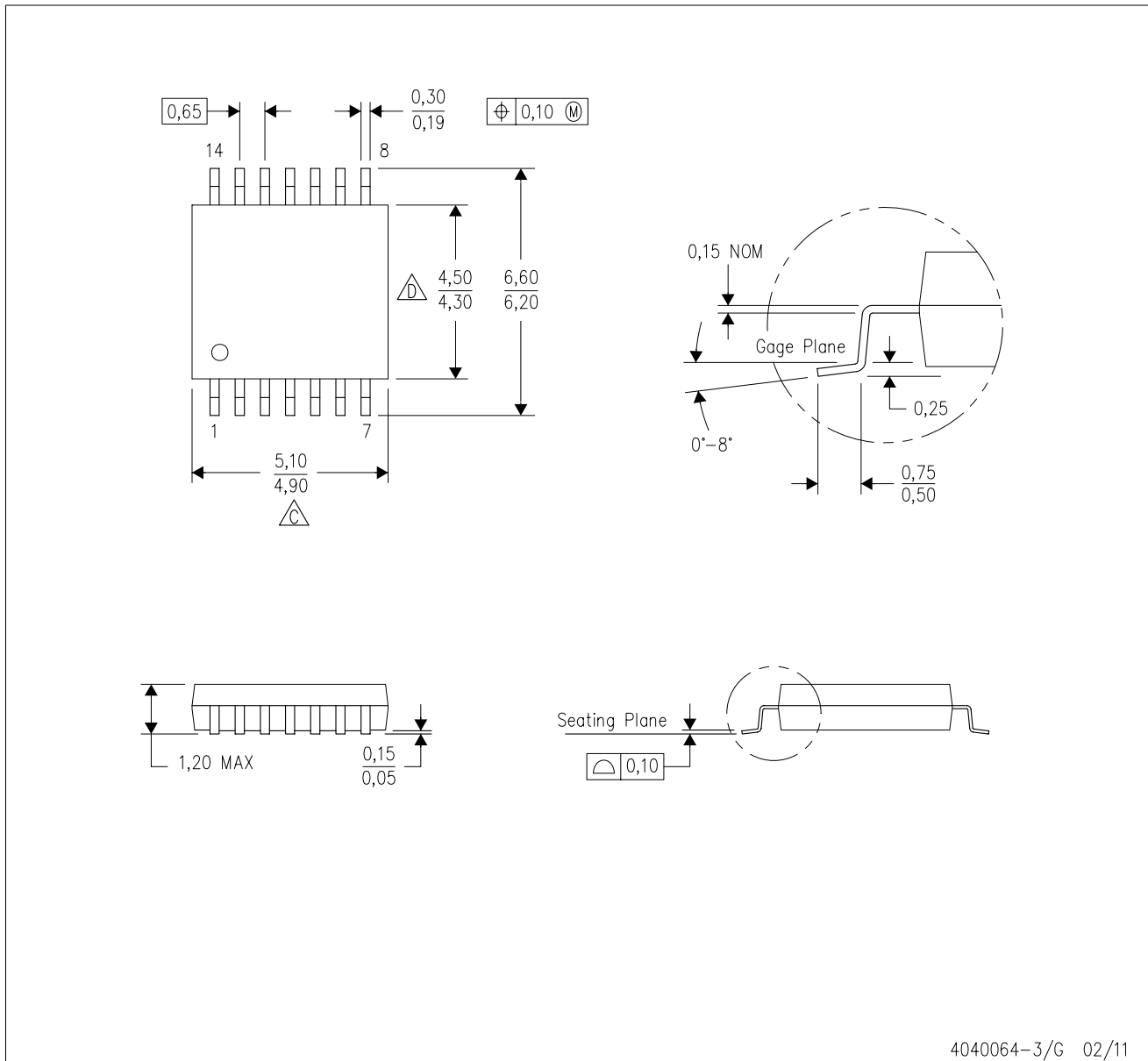

4040064-3/G 02/11

- NOTES:
- A. All linear dimensions are in millimeters. Dimensioning and tolerancing per ASME Y14.5M-1994.
  - B. This drawing is subject to change without notice.
  - C. Body length does not include mold flash, protrusions, or gate burrs. Mold flash, protrusions, or gate burrs shall not exceed 0,15 each side.
  - D. Body width does not include interlead flash. Interlead flash shall not exceed 0,25 each side.
  - E. Falls within JEDEC MO-153

PW (R-PDSO-G14)

PLASTIC SMALL OUTLINE

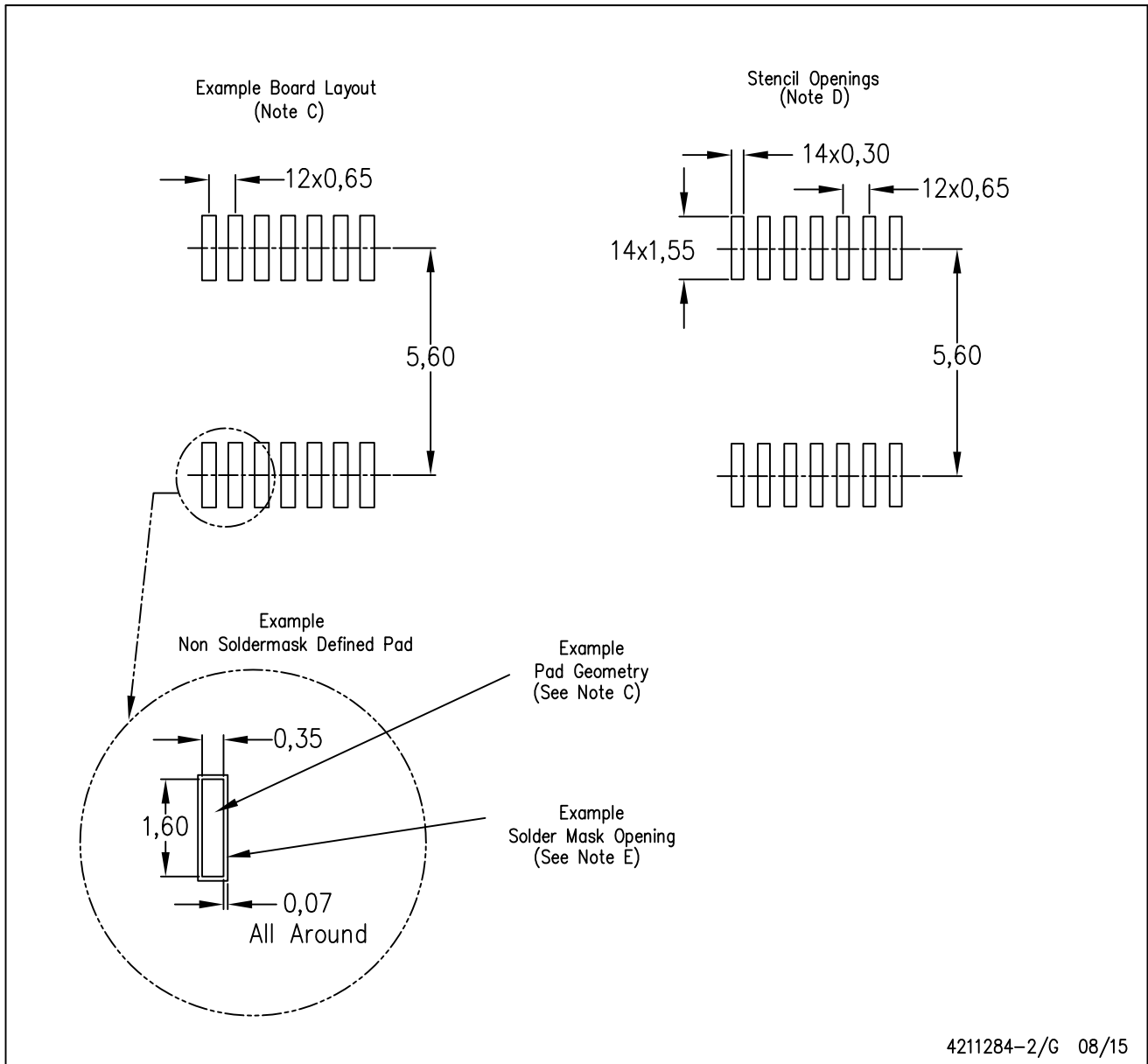

4211284-2/G 08/15

- NOTES:
- A. All linear dimensions are in millimeters.
  - B. This drawing is subject to change without notice.
  - C. Publication IPC-7351 is recommended for alternate designs.
  - D. Laser cutting apertures with trapezoidal walls and also rounding corners will offer better paste release. Customers should contact their board assembly site for stencil design recommendations. Refer to IPC-7525 for other stencil recommendations.
  - E. Customers should contact their board fabrication site for solder mask tolerances between and around signal pads.

## 重要声明和免责声明

TI“按原样”提供技术和可靠性数据（包括数据表）、设计资源（包括参考设计）、应用或其他设计建议、网络工具、安全信息和其他资源，不保证没有瑕疵且不做任何明示或暗示的担保，包括但不限于对适销性、某特定用途方面的适用性或不侵犯任何第三方知识产权的暗示担保。

这些资源可供使用 TI 产品进行设计的熟练开发人员使用。您将自行承担以下全部责任：(1) 针对您的应用选择合适的 TI 产品，(2) 设计、验证并测试您的应用，(3) 确保您的应用满足相应标准以及任何其他功能安全、信息安全、监管或其他要求。

这些资源如有变更，恕不另行通知。TI 授权您仅可将这些资源用于研发本资源所述的 TI 产品的应用。严禁对这些资源进行其他复制或展示。您无权使用任何其他 TI 知识产权或任何第三方知识产权。您应全额赔偿因在这些资源的使用中对 TI 及其代表造成的任何索赔、损害、成本、损失和债务，TI 对此概不负责。

TI 提供的产品受 [TI 的销售条款](#) 或 [ti.com](#) 上其他适用条款/TI 产品随附的其他适用条款的约束。TI 提供这些资源并不会扩展或以其他方式更改 TI 针对 TI 产品发布的适用的担保或担保免责声明。

TI 反对并拒绝您可能提出的任何其他或不同的条款。

邮寄地址：Texas Instruments, Post Office Box 655303, Dallas, Texas 75265

Copyright © 2022，德州仪器 (TI) 公司