

CD405xB CMOS Single 8-Channel Analog Multiplexer/Demultiplexer with Logic-Level Conversion

1 Features

- Wide Range of Digital and Analog Signal Levels
 - Digital: 3 V to 20 V
 - Analog: $\leq 20 V_{P-P}$
- Low ON Resistance, 125 Ω (Typical) Over 15 V_{P-P} Signal Input Range for $V_{DD} - V_{EE} = 18 V$
- High OFF Resistance, Channel Leakage of $\pm 100 \mu A$ (Typical) at $V_{DD} - V_{EE} = 18 V$
- Logic-Level Conversion for Digital Addressing Signals of 3 V to 20 V ($V_{DD} - V_{SS} = 3 V$ to 20 V) to Switch Analog Signals to 20 V_{P-P} ($V_{DD} - V_{EE} = 20 V$) Matched Switch Characteristics, $r_{ON} = 5 \Omega$ (Typical) for $V_{DD} - V_{EE} = 15 V$ Very Low Quiescent Power Dissipation Under All Digital-Control Input and Supply Conditions, 0.2 μW (Typical) at $V_{DD} - V_{SS} = V_{DD} - V_{EE} = 10 V$
- Binary Address Decoding on Chip
- 5 V, 10 V, and 15 V Parametric Ratings
- 100% Tested for Quiescent Current at 20 V
- Maximum Input Current of 1 μA at 18 V Over Full Package Temperature Range, 100 nA at 18 V and 25°C
- Break-Before-Make Switching Eliminates Channel Overlap

2 Applications

- Analog and Digital Multiplexing and Demultiplexing
- A/D and D/A Conversion
- Signal Gating
- Factory Automation
- Televisions
- Appliances
- Consumer Audio
- Programmable Logic Circuits
- Sensors

3 Description

The CD405xB analog multiplexers and demultiplexers are digitally-controlled analog switches having low ON impedance and very low OFF leakage current. These multiplexer circuits dissipate extremely low quiescent power over the full $V_{DD} - V_{SS}$ and $V_{DD} - V_{EE}$ supply-voltage ranges, independent of the logic state of the control signals.

Device Information⁽¹⁾

PART NUMBER	PACKAGE	BODY SIZE (NOM)
CD405xB	CDIP (16)	19.50 mm x 6.92 mm
	PDIP (16)	19.30 mm x 6.35 mm
	SOIC (16)	9.90 mm x 3.91 mm
	SOP (16)	10.30 mm x 5.30 mm
	TSSOP (16)	5.00 mm x 4.40 mm

(1) For all available packages, see the orderable addendum at the end of the data sheet.

Functional Diagrams of CD405xB

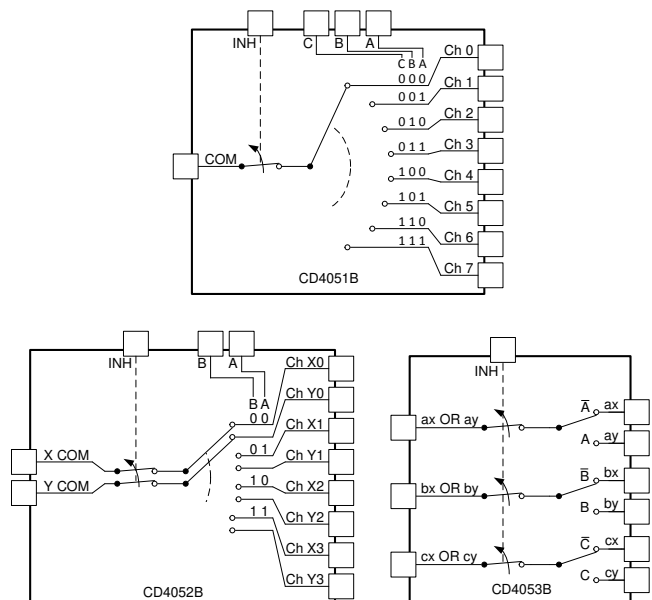

Table of Contents

1 Features	1	8.4 Device Functional Modes.....	18
2 Applications	1	9 Application and Implementation	19
3 Description	1	9.1 Application Information.....	19
4 Revision History	2	9.2 Typical Application	19
5 Pin Configuration and Functions	3	10 Power Supply Recommendations	20
6 Specifications	5	11 Layout	21
6.1 Absolute Maximum Ratings	5	11.1 Layout Guidelines	21
6.2 ESD Ratings.....	5	11.2 Layout Example	21
6.3 Recommended Operating Conditions.....	5	12 Device and Documentation Support	22
6.4 Thermal Information	5	12.1 Documentation Support	22
6.5 Electrical Characteristics.....	6	12.2 Related Links	22
6.6 AC Performance Characteristics.....	8	12.3 Receiving Notification of Documentation Updates	22
6.7 Typical Characteristics	9	12.4 Community Resources.....	22
7 Parameter Measurement Information	10	12.5 Trademarks	22
8 Detailed Description	15	12.6 Electrostatic Discharge Caution.....	22
8.1 Overview	15	12.7 Glossary	22
8.2 Functional Block Diagrams	15	13 Mechanical, Packaging, and Orderable	
8.3 Feature Description.....	17	Information	22

4 Revision History

Changes from Revision H (April 2015) to Revision I	Page
• Added: ON Channel Leakage Current to the <i>Electrical Characteristics</i> table	6
• Added Note 3 to the <i>Electrical Characteristics</i> table	6
• Added Figure 13	11

Changes from Revision G (October 2003) to Revision H	Page
• Added <i>Pin Configuration and Functions</i> section, <i>ESD Ratings</i> table, <i>Feature Description</i> section, <i>Device Functional Modes</i> , <i>Application and Implementation</i> section, <i>Power Supply Recommendations</i> section, <i>Layout</i> section, <i>Device and Documentation Support</i> section, and <i>Mechanical, Packaging, and Orderable Information</i> section	1
• Added <i>Device Information</i> table.	1

5 Pin Configuration and Functions

CD4051B E, M, NS, and PW Package
16-Pin PDIP, CDIP, SOIC, SOP, and TSSOP
(Top View)

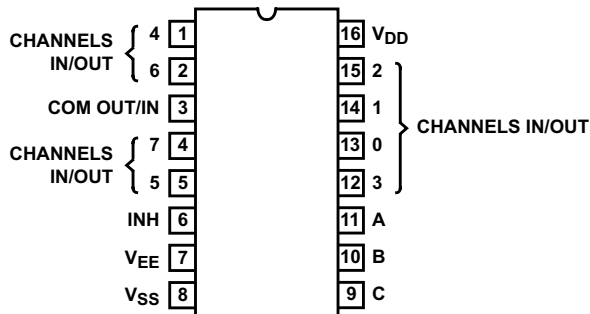

CD4052B E, M, NS, and PW Package
16-Pin PDIP, CDIP, SOP, and TSSOP
(Top View)

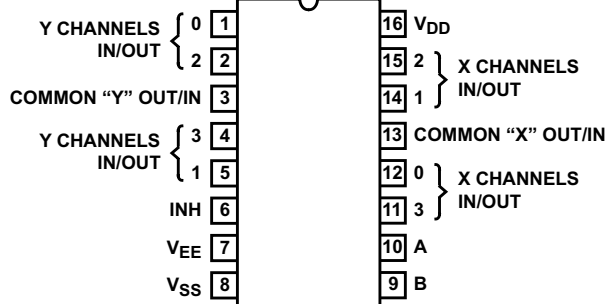

CD4053B E, M, NS, and PW Package
16-Pin PDIP, CDIP, SOP, and TSSOP
(Top View)

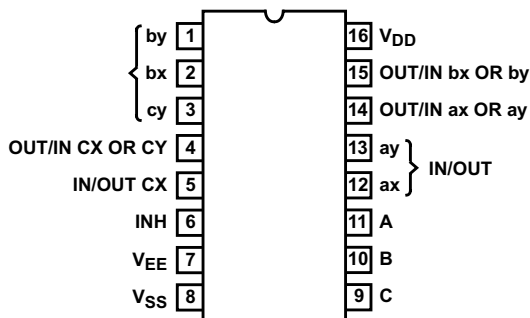

Pin Functions CD4051B

PIN		I/O	DESCRIPTION
NO.	NAME		
1	CH 4 IN/OUT	I/O	Channel 4 in/out
2	CH 6 IN/OUT	I/O	Channel 6 in/out
3	COM OUT/IN	I/O	Common out/in
4	CH 7 IN/OUT	I/O	Channel 7 in/out
5	CH 5 IN/OUT	I/O	Channel 5 in/out
6	INH	I	Disables all channels. See Table 1 .
7	V _{EE}	—	Negative power input
8	V _{SS}	—	Ground
9	C	I	Channel select C. See Table 1 .
10	B	I	Channel select B. See Table 1 .
11	A	I	Channel select A. See Table 1 .
12	CH 3 IN/OUT	I/O	Channel 3 in/out
13	CH 0 IN/OUT	I/O	Channel 0 in/out
14	CH 1 IN/OUT	I/O	Channel 1 in/out
15	CH 2 IN/OUT	I/O	Channel 2 in/out
16	V _{DD}	—	Positive power input

Pin Functions CD4052B

PIN		I/O	DESCRIPTION
NO.	NAME		
1	Y CH 0 IN/OUT	I/O	Channel Y0 in/out
2	Y CH 2 IN/OUT	I/O	Channel Y2 in/out
3	Y COM OUT/IN	I/O	Y common out/in
4	Y CH 3 IN/OUT	I/O	Channel Y3 in/out
5	Y CH 1 IN/OUT	I/O	Channel Y1 in/out
6	INH	I	Disables all channels. See Table 1 .
7	V _{EE}	—	Negative power input
8	V _{SS}	—	Ground
9	B	I	Channel select B. See Table 1 .
10	A	I	Channel select A. See Table 1 .
11	X CH 3 IN/OUT	I/O	Channel X3 in/out
12	X CH 0 IN/OUT	I/O	Channel X0 in/out
13	X COM IN/OUT	I/O	X common out/in
14	X CH 1 IN/OUT	I/O	Channel in/out
15	X CH 2 IN/OUT	I/O	Channel in/out
16	V _{DD}	—	Positive power input

Pin Functions CD4053B

PIN		I/O	DESCRIPTION
NO.	NAME		
1	BY IN/OUT	I/O	B channel Y in/out
2	BX IN/OUT	I/O	B channel X in/out
3	CY IN/OUT	I/O	C channel Y in/out
4	CX OR CY OUT/IN	I/O	C common out/in
5	CX IN/OUT	I/O	C channel X in/out
6	INH	I	Disables all channels. See Table 1 .
7	V _{EE}	—	Negative power input
8	V _{SS}	—	Ground
9	C	I	Channel select C. See Table 1 .
10	B	I	Channel select B. See Table 1 .
11	A	I	Channel select A. See Table 1 .
12	AX IN/OUT	I/O	A channel X in/out
13	AY IN/OUT	I/O	A channel Y in/out
14	AX OR AY OUT/IN	I/O	A common out/in
15	BX OR BY OUT/IN	I/O	B common out/in
16	V _{DD}	—	Positive power input

6 Specifications

6.1 Absolute Maximum Ratings

Over operating free-air temperature range (unless otherwise noted)⁽¹⁾.

		MIN	MAX	UNIT
Supply Voltage	V+ to V-, Voltages Referenced to V _{SS} Terminal	-0.5	20	V
DC Input Voltage		-0.5	V _{DD} + 0.5	V
DC Input Current	Any One Input	-10	10	mA
T _{JMAX1}	Maximum junction temperature, ceramic package		175	°C
T _{JMAX2}	Maximum junction temperature, plastic package		150	°C
T _{stg}	Storage temperature	-65	150	°C

- (1) Stresses beyond those listed under *Absolute Maximum Ratings* may cause permanent damage to the device. These are stress ratings only, which do not imply functional operation of the device at these or any other conditions beyond those indicated under *Recommended Operating Conditions*. Exposure to absolute-maximum-rated conditions for extended periods may affect device reliability.

6.2 ESD Ratings

		VALUE	UNIT
CD4051B in PDIP, CDIP, SOIC, SOP, TSSOP Packages			
V _(ESD)	Electrostatic discharge	Human-body model (HBM), per ANSI/ESDA/JEDEC JS-001 ⁽¹⁾	+3000
		Charged-device model (CDM), per JEDEC specification JESD22-C101 ⁽²⁾	+2000
CD4053B in PDIP, CDIP, SOP and TSSOP Packages			
V _(ESD)	Electrostatic discharge	Human-body model (HBM), per ANSI/ESDA/JEDEC JS-001 ⁽¹⁾	+2500
		Charged-device model (CDM), per JEDEC specification JESD22-C101 ⁽²⁾	+1500

- (1) JEDEC document JEP155 states that 500-V HBM allows safe manufacturing with a standard ESD control process.

- (2) JEDEC document JEP157 states that 250-V CDM allows safe manufacturing with a standard ESD control process.

6.3 Recommended Operating Conditions

Over operating free-air temperature range (unless otherwise noted).

	MIN	MAX	UNIT
Temperature Range	-55	125	°C

6.4 Thermal Information

THERMAL METRIC ⁽¹⁾	CD405xB				UNIT	
	E (PDIP)	M (SOIC)	NS (SOP)	PW (TSSOP)		
	16 PINS	16 PINS	16 PINS	16 PINS		
R _{θJA}	Junction-to-ambient thermal resistance	67	73	64	108	°C/W

- (1) For more information about traditional and new thermal metrics, see the [Semiconductor and IC Package Thermal Metrics](#) application report.

6.5 Electrical Characteristics

 Over operating free-air temperature range, $V_{\text{SUPPLY}} = \pm 5 \text{ V}$, and $R_L = 100 \Omega$, (unless otherwise noted)⁽¹⁾.

PARAMETER	TEST CONDITIONS					MIN	TYP	MAX	UNIT	
	V_{IS} (V)	V_{EE} (V)	V_{SS} (V)	V_{DD} (V)	TEMP					
SIGNAL INPUTS (V_{IS}) AND OUTPUTS (V_{OS})										
Quiescent Device Current, I_{DD} Max	5				-55°C			5	μA	
					-40°C			5		
					25°C	0.04		5		
					85°C			150		
					125°C			150		
	10					-55°C				10
						-40°C				10
						25°C	0.04			10
						85°C				300
						125°C				300
	15					-55°C				20
						-40°C				20
						25°C	0.04			20
						85°C				600
						125°C				600
	20					-55°C				100
						-40°C				100
						25°C	0.08			100
						85°C				3000
						125°C				3000
Drain to Source ON Resistance r_{ON} Max $0 \leq V_{\text{IS}} \leq V_{\text{DD}}$	5	0	0		-55°C			800	Ω	
					-40°C			850		
					25°C	470		1050		
					85°C			1200		
					125°C			1300		
	10	0	0			-55°C				310
						-40°C				300
						25°C	180			400
						85°C				520
	15	0	0			-55°C				200
						-40°C				210
						25°C	125			240
85°C								300		
Change in ON Resistance (Between Any Two Channels), Δr_{ON}	5	0	0		25°C			15	Ω	
								10		10
								15		5
OFF Channel Leakage Current: Any Channel OFF (Max) or ALL Channels OFF (Common OUT/IN) (Max)	18	0	0		-55°C			± 100	nA	
					-40°C					
					25°C	± 0.01		$\pm 100^{(2)}$		
					85°C			$\pm 1000^{(2)}$		
					125°C					
ON Channel Leakage Current: Any Channel ON (Max) or ALL Channels ON (Common OUT/IN) (Max)	5 or 0	-5	0	10.5	85°C			$\pm 300^{(3)}$	nA	
	5	0	0	18	85°C			$\pm 300^{(3)}$		
Capacitance	Input, C_{IS}	-5	-5	-5	25°C			5	pF	
	Output, C_{OS}				25°C			30		
								CD4052		18
								CD4053		9
Feed through, C_{IOS}							0.2			

 (1) Peak-to-Peak voltage symmetrical about $(V_{\text{DD}} - V_{\text{EE}}) / 2$.

(2) Determined by minimum feasible leakage measurement for automatic testing.

(3) Does not apply to Hi-Rel CD4051BF and CD4051BFA3 devices.

Electrical Characteristics (continued)

Over operating free-air temperature range, $V_{\text{SUPPLY}} = \pm 5 \text{ V}$, and $R_L = 100 \Omega$, (unless otherwise noted)⁽¹⁾.

PARAMETER		TEST CONDITIONS					MIN	TYP	MAX	UNIT	
		V_{IS} (V)	V_{EE} (V)	V_{SS} (V)	V_{DD} (V)	TEMP					
Propagation Delay Time (Signal Input to Output)		V_{DD}	$R_L = 200 \text{ k}\Omega$,		5	25°C	30	60	ns		
			$C_L = 50 \text{ pF}$,		10		15	30			
		$t_r, t_f = 20 \text{ ns}$		15	10		20				
CONTROL (ADDRESS OR INHIBIT), V_C											
Input Low Voltage, V_{IL} , Max		$V_{\text{IL}} = V_{\text{DD}}$ through 1 k Ω ; $V_{\text{IH}} = V_{\text{DD}}$ through 1 k Ω	$V_{\text{EE}} = V_{\text{SS}}$, $R_L = 1 \text{ k}\Omega$ to V_{SS} , $I_{\text{IS}} < 2 \mu\text{A}$ on All OFF Channels				5	-55°C	1.5	V	
							5	-40°C	1.5		
							5	25°C	1.5		
							5	85°C	1.5		
							5	125°C	1.5		
							10	-55°C	3		
							10	-40°C	3		
							10	25°C	3		
							10	85°C	3		
							10	125°C	3		
							15	-55°C	4		
							15	-40°C	4		
							15	25°C	4		
							15	85°C	4		
							Input High Voltage, V_{IH} , Min		$V_{\text{IL}} = V_{\text{DD}}$ through 1 k Ω ; $V_{\text{IH}} = V_{\text{DD}}$ through 1 k Ω		$V_{\text{EE}} = V_{\text{SS}}$, $R_L = 1 \text{ k}\Omega$ to V_{SS} , $I_{\text{IS}} < 2 \mu\text{A}$ on All OFF Channels
5	-40°C	3.5									
5	25°C	3.5									
5	85°C	3.5									
5	125°C	3.5									
10	-55°C	7									
10	-40°C	7									
10	25°C	7									
10	85°C	7									
10	125°C	7									
15	-55°C	11									
15	-40°C	11									
15	25°C	11									
15	85°C	11									
Input Current, I_{IN} (Max)			$V_{\text{IN}} = 0, 18$							18	
							18	-40°C	± 0.1		
							18	25°C	$\pm 10^{-5}$	± 0.1	
							18	85°C	± 1		
							18	125°C	± 1		
Propagation Delay Time	Address-to-Signal OUT (Channels ON or OFF) (See Figure 10, Figure 11, and Figure 15)	$t_r, t_f = 20 \text{ ns}$, $C_L = 50 \text{ pF}$, $R_L = 10 \text{ k}\Omega$	0	0	5		450	720	ns		
			0	0	10		160	320			
			0	0	15		120	240			
			-5	0	5		225	450			
Propagation Delay Time	Inhibit-to-Signal OUT (Channel Turning ON) (See Figure 11)	$t_r, t_f = 20 \text{ ns}$, $C_L = 50 \text{ pF}$, $R_L = 1 \text{ k}\Omega$	0	0	5		400	720	ns		
			0	0	10		160	320			
			0	0	15		120	240			
			-10	0	5		200	400			
Propagation Delay Time	Inhibit-to-Signal OUT (Channel Turning OFF) (See Figure 17)	$t_r, t_f = 20 \text{ ns}$, $C_L = 50 \text{ pF}$, $R_L = 10 \text{ k}\Omega$	0	0	5		200	450	ns		
			0	0	10		90	210			
			0	0	15		70	160			
			-10	0	5		130	300			
Input Capacitance, C_{IN} (Any Address or Inhibit Input)							5	7.5	pF		

6.6 AC Performance Characteristics

PARAMETER	TEST CONDITIONS				TYP	UNIT		
	V _{IS} (V)	V _{DD} (V)	R _L (kΩ)					
Cutoff (–3dB) Frequency Channel ON (Sine Wave Input)	5 ⁽¹⁾	10	1	V _{OS} at Common OUT/IN	CD4053	30	MHz	
					CD4052	25		
				V _{OS} at Any Channel		60		
	$V_{EE} = V_{SS},$ $20 \text{Log} \frac{V_{OS}}{V_{IS}} = -3 \text{ dB}$							
Total Harmonic Distortion, THD	2 ⁽¹⁾	5	10			0.3%		
	3 ⁽¹⁾	10				0.2%		
	5 ⁽¹⁾	15				0.12%		
	$V_{EE} = V_{SS}, f_{IS} = 1 \text{ kHz Sine Wave}$							
–40dB Feedthrough Frequency (All Channels OFF)	5 ⁽¹⁾	10	1	V _{OS} at Common OUT/IN	CD4053	8	MHz	
					CD4052	10		
					V _{OS} at Any Channel		8	
	$V_{EE} = V_{SS},$ $20 \text{Log} \frac{V_{OS}}{V_{IS}} = -40 \text{ dB}$							
–40dB Signal Crosstalk Frequency	5 ⁽¹⁾	10	1	Between Any two Channels		3	MHz	
				Between Sections, CD4052 Only	Measured on Common	6		
					Measured on Any Channel	10		
				Between Any Two Sections, CD4053 Only	In Pin 2, Out Pin 14	2.5		
					In Pin 15, Out Pin 14	6		
Address-or-Inhibit-to- Signal Crosstalk		10	10 ⁽²⁾			65	mV _{PEAK}	
	$V_{EE} = 0, V_{SS} = 0, t_r, t_f = 20 \text{ ns},$ $V_{CC} = V_{DD} - V_{SS} \text{ (Square Wave)}$					65		

- (1) Peak-to-Peak voltage symmetrical about $(V_{DD} - V_{EE}) / 2$.
 (2) Both ends of channel.

6.7 Typical Characteristics

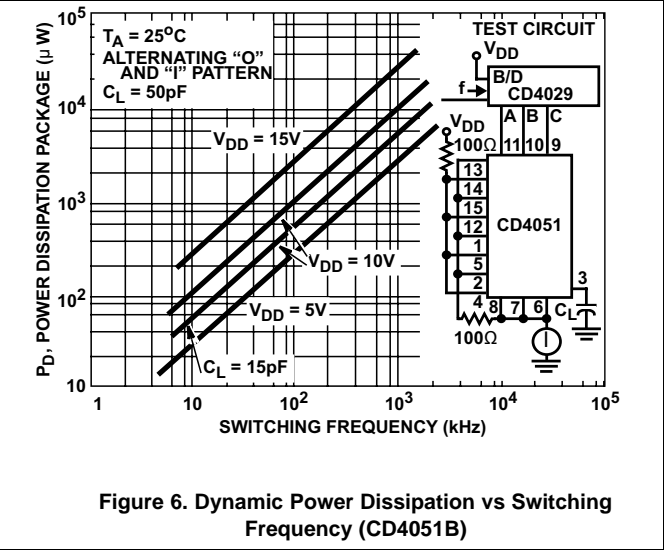
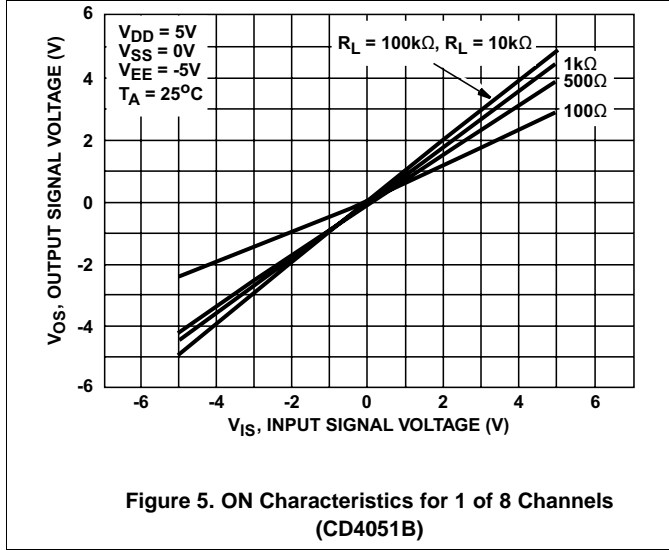
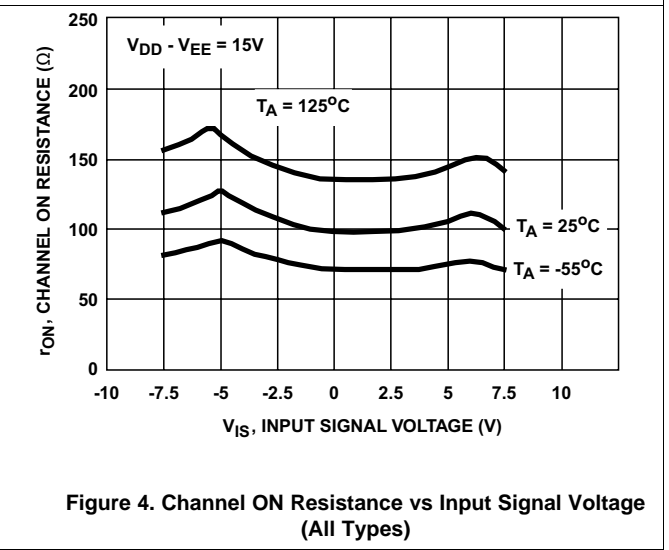
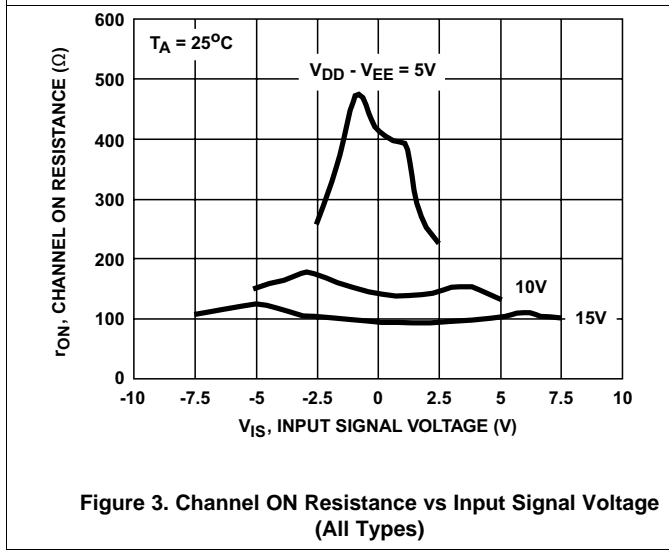
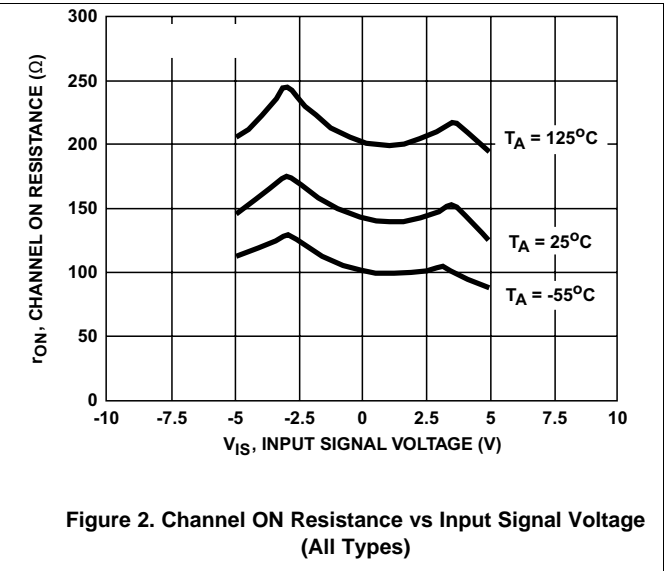
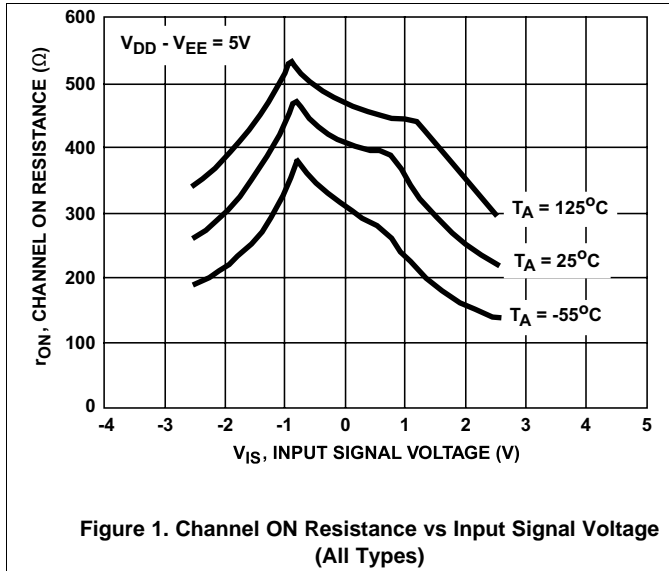

Typical Characteristics (continued)

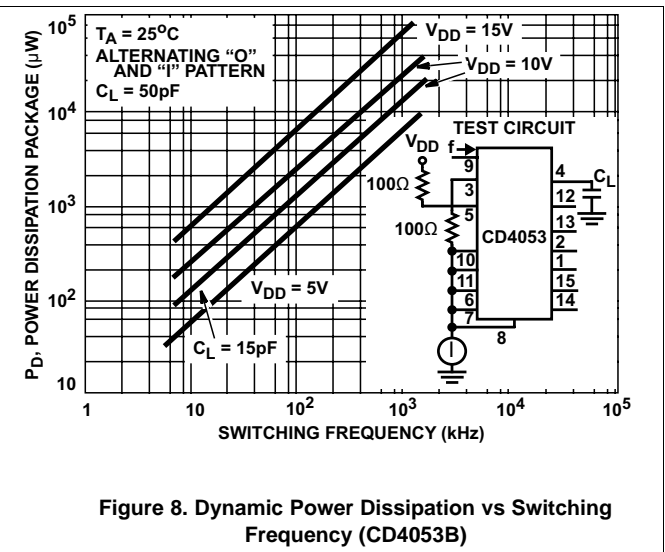
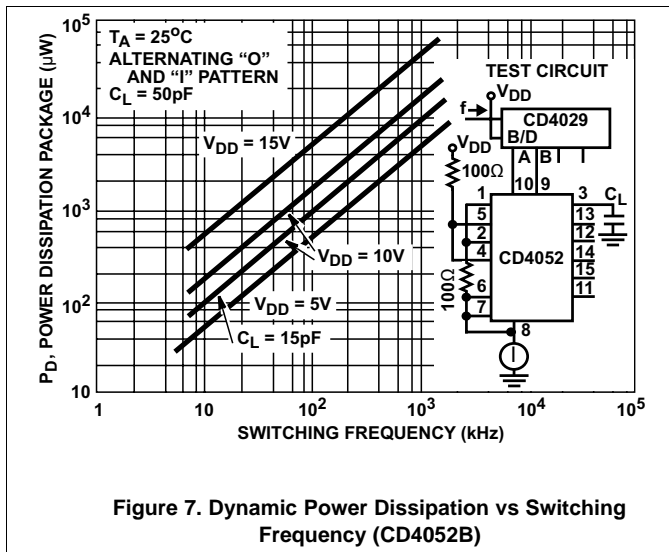

7 Parameter Measurement Information

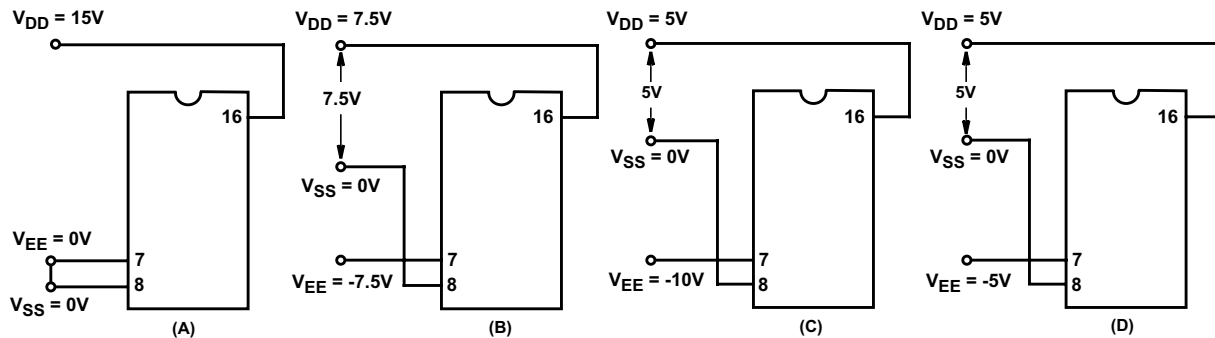

Figure 9. Typical Bias Voltages

NOTE

The ADDRESS (digital-control inputs) and INHIBIT logic levels are: 0 = V_{SS} and 1 = V_{DD} . The analog signal (through the TG) may swing from V_{EE} to V_{DD} .

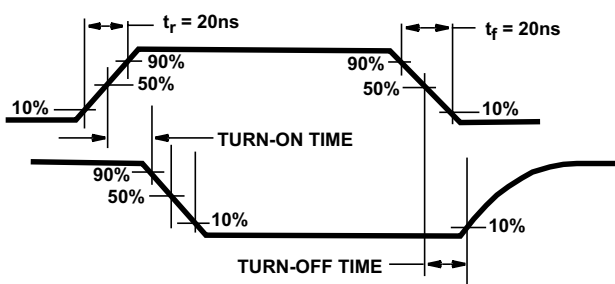

Figure 10. Waveforms, Channel Being Turned ON ($R_L = 1\text{ k}\Omega$)

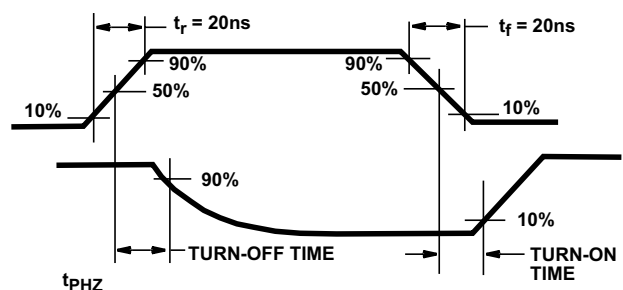

Figure 11. Waveforms, Channel Being Turned OFF ($R_L = 1\text{ k}\Omega$)

Parameter Measurement Information (continued)

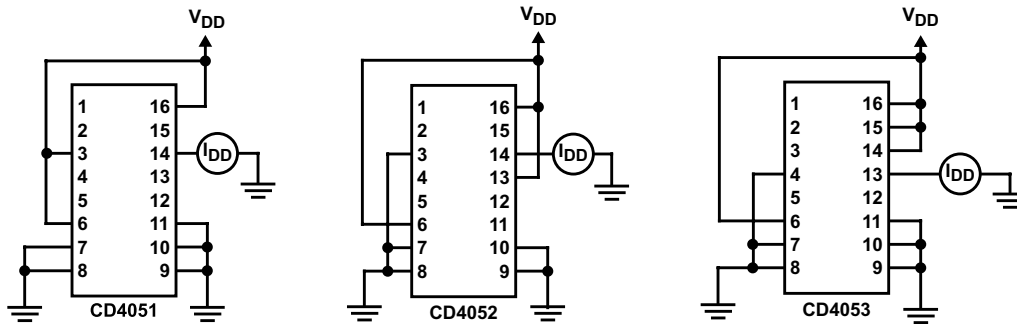
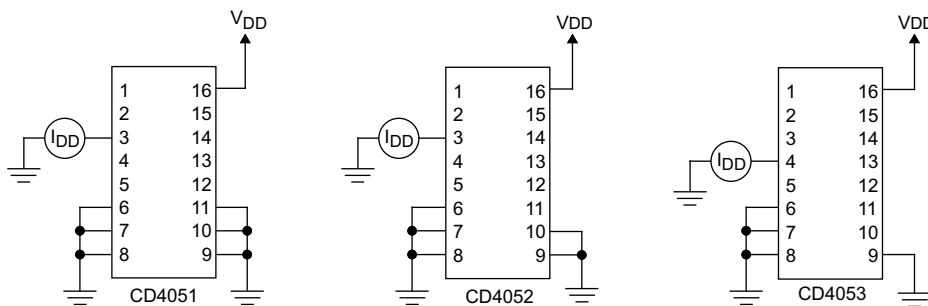

Figure 12. OFF Channel Leakage Current - Any Channel OFF



Copyright © 2017, Texas Instruments Incorporated

Figure 13. On Channel Leakage Current - Any Channel On

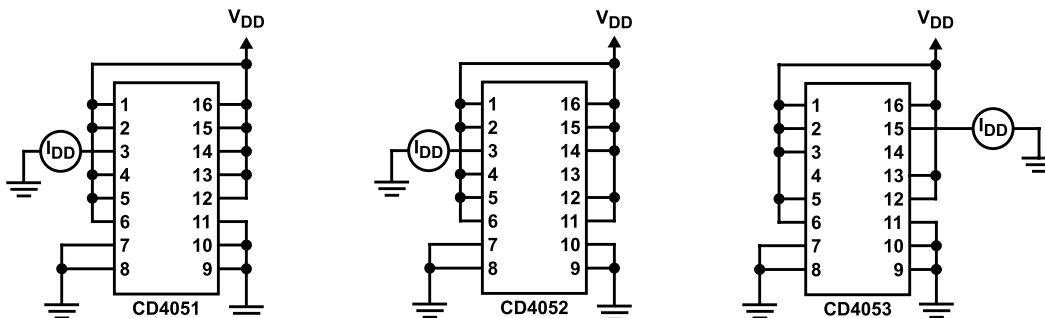

Figure 14. OFF Channel Leakage Current - All Channels OFF

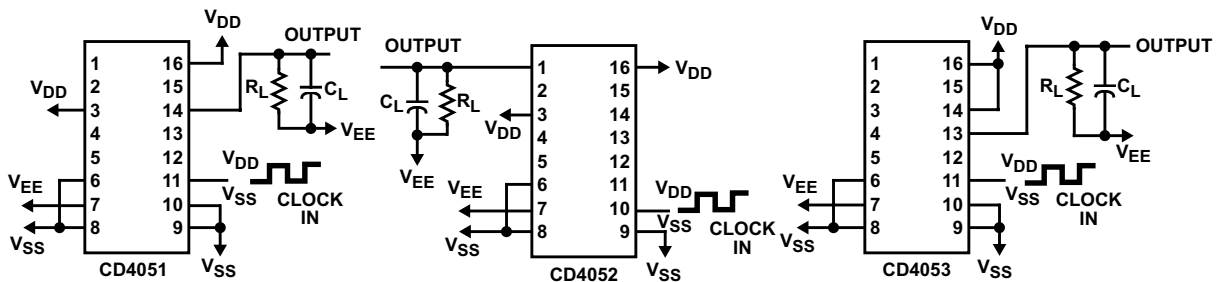

Figure 15. Propagation Delay - Address Input to Signal Output

Parameter Measurement Information (continued)

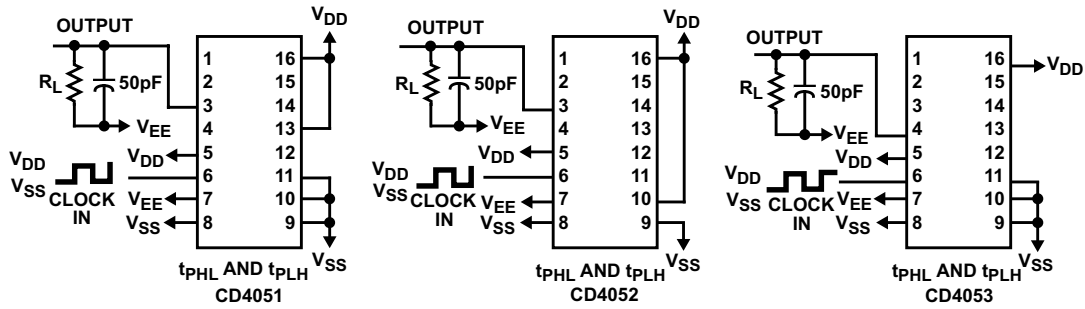

Figure 16. Propagation Delay - Inhibit Input to Signal Output

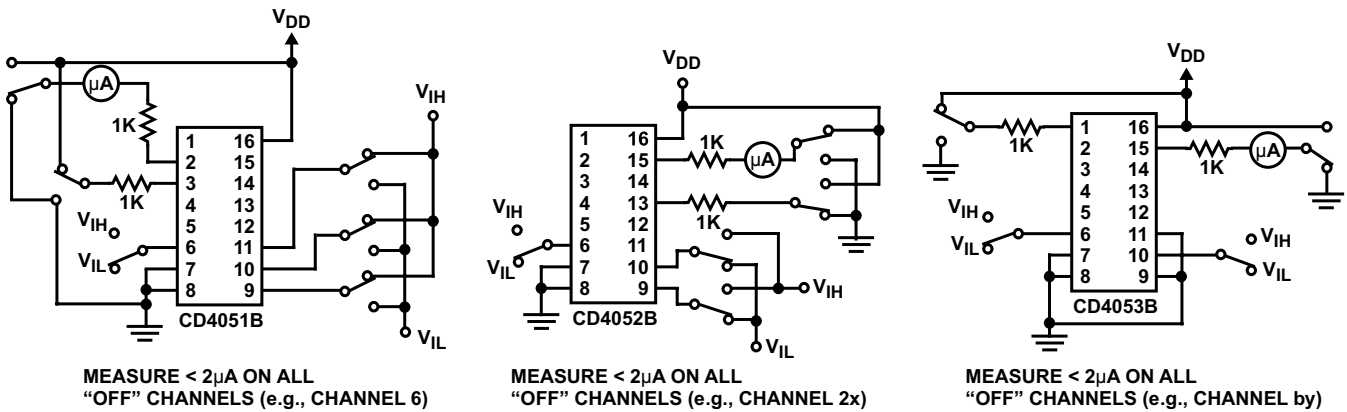

Figure 17. Input Voltage Test Circuits (Noise Immunity)

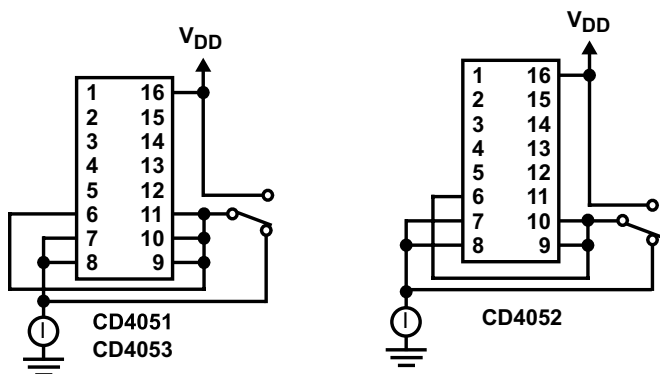

Figure 18. Quiescent Device Current

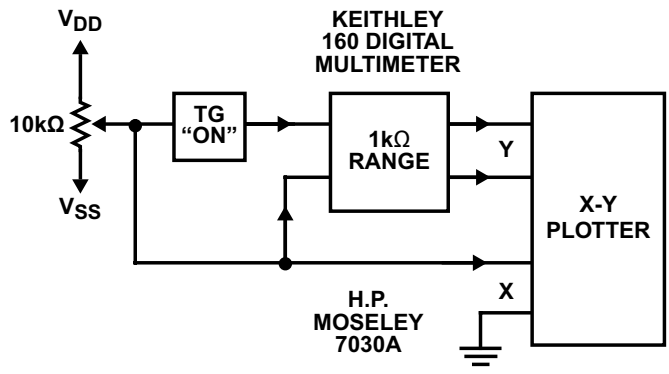

Figure 19. Channel ON Resistance Measurement Circuit

Parameter Measurement Information (continued)

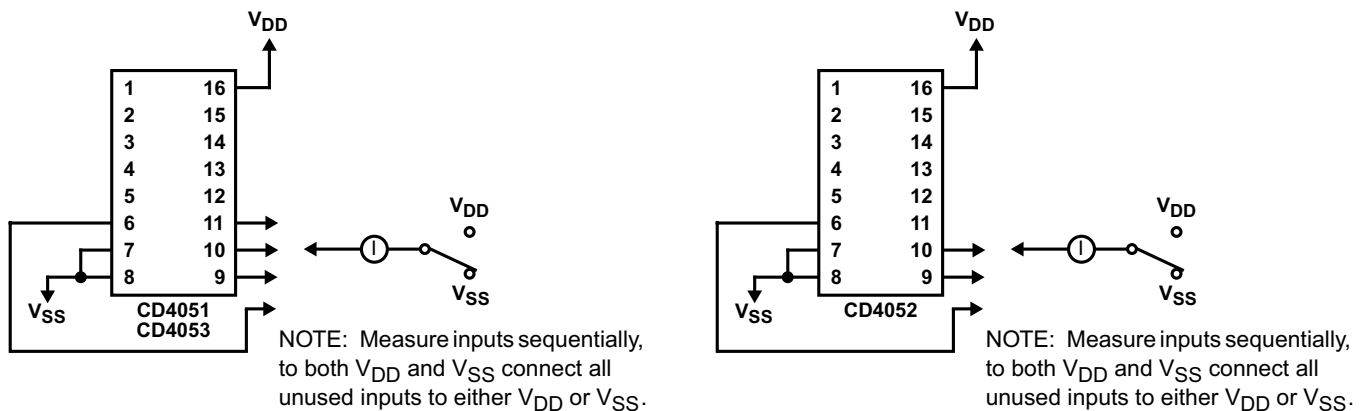

Figure 20. Input Current

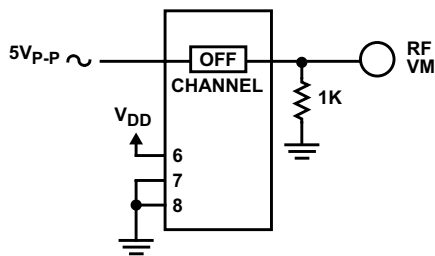

Figure 21. Feedthrough (All Types)

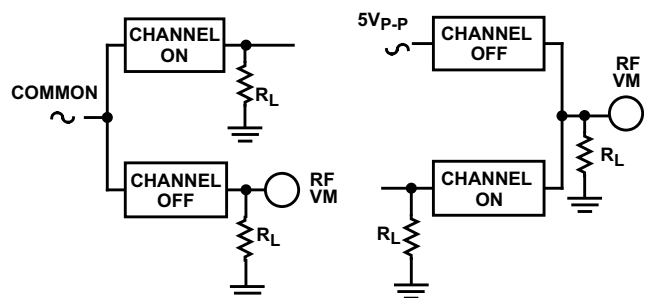

Figure 22. Crosstalk Between Any Two Channels (All Types)

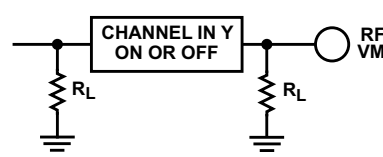
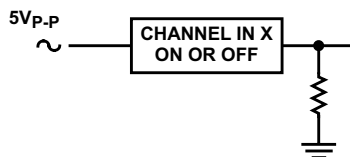
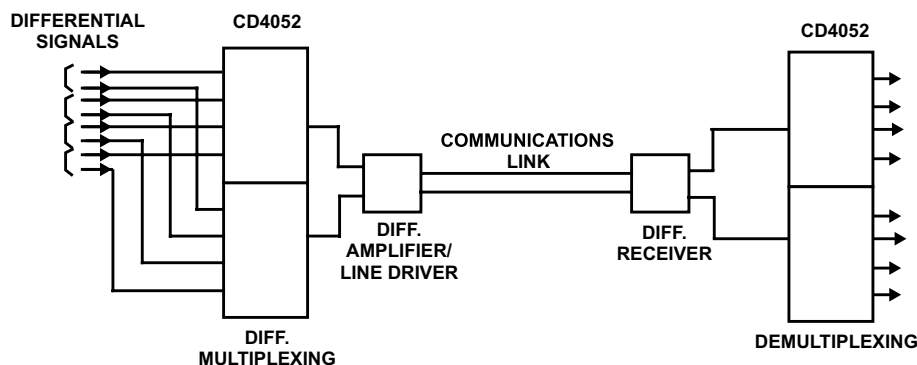

Figure 23. Crosstalk Between Duals or Triplets (CD4052B, CD4053B)



Special Considerations: In applications where separate power sources are used to drive V_{DD} and the signal inputs, the V_{DD} current capability should exceed V_{DD}/R_L (R_L = effective external load). This provision avoids permanent current flow or clamp action on the V_{DD} supply when power is applied or removed from the CD4051B, CD4052B or CD4053B.

Figure 24. Typical Time-Division Application of the CD4052B

Parameter Measurement Information (continued)

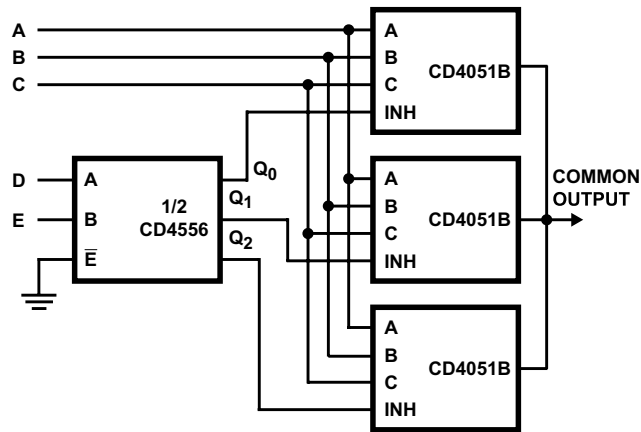

Figure 25. 24-to-1 MUX Addressing

8 Detailed Description

8.1 Overview

The CD4051B, CD4052B, and CD4053B analog multiplexers are digitally-controlled analog switches having low ON impedance and very low OFF leakage current. Control of analog signals up to 20 V_{P-P} can be achieved by digital signal amplitudes of 4.5 V to 20 V (if $V_{DD} - V_{SS} = 3$ V, a $V_{DD} - V_{EE}$ of up to 13 V can be controlled; for $V_{DD} - V_{EE}$ level differences above 13 V, a $V_{DD} - V_{SS}$ of at least 4.5 V is required). For example, if $V_{DD} = +4.5$ V, $V_{SS} = 0$ V, and $V_{EE} = -13.5$ V, analog signals from -13.5 V to $+4.5$ V can be controlled by digital inputs of 0 V to 5 V. These multiplexer circuits dissipate extremely low quiescent power over the full $V_{DD} - V_{SS}$ and $V_{DD} - V_{EE}$ supply-voltage ranges, independent of the logic state of the control signals. When a logic 1 is present at the inhibit input terminal, all channels are off.

The CD4051B device is a single 8-channel multiplexer having three binary control inputs, A, B, and C, and an inhibit input. The three binary signals select 1 of 8 channels to be turned on, and connect one of the 8 inputs to the output.

The CD4052B device is a differential 4-channel multiplexer having two binary control inputs, A and B, and an inhibit input. The two binary input signals select 1 of 4 pairs of channels to be turned on and connect the analog inputs to the outputs.

The CD4053B device is a triple 2-channel multiplexer having three separate digital control inputs, A, B, and C, and an inhibit input. Each control input selects one of a pair of channels which are connected in a single-pole, double-throw configuration.

When these devices are used as demultiplexers, the CHANNEL IN/OUT terminals are the outputs and the COMMON OUT/IN terminals are the inputs.

8.2 Functional Block Diagrams

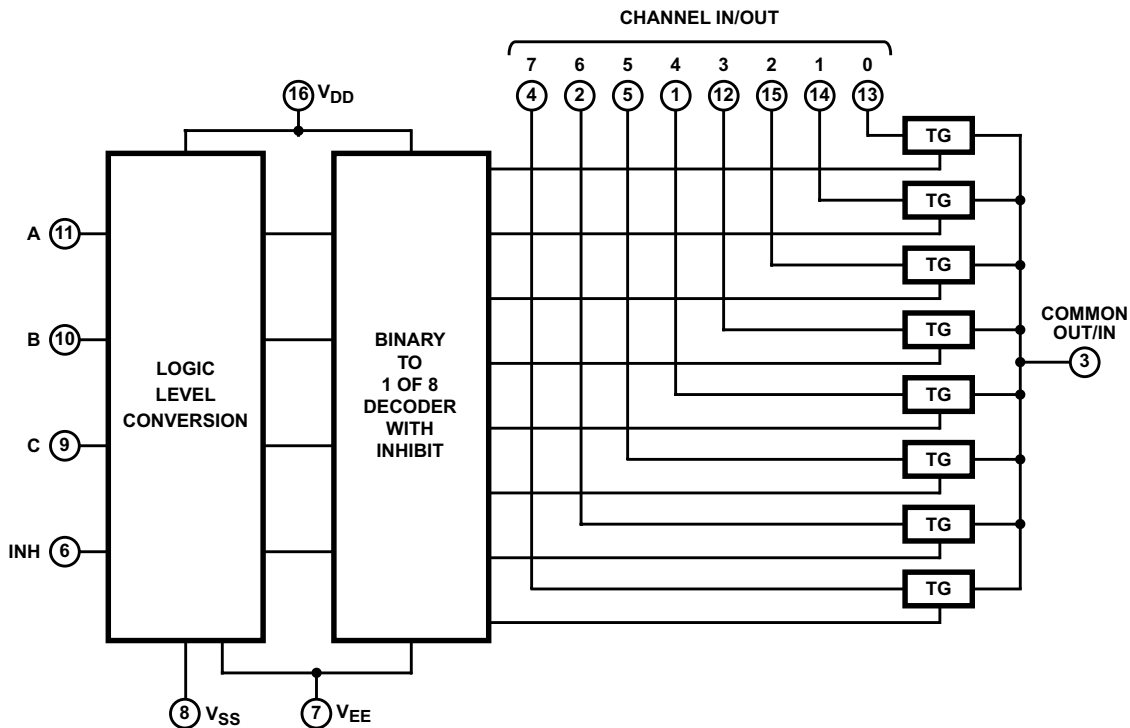

All inputs are protected by standard CMOS protection network.

Figure 26. Functional Block Diagram, CD4051B

Functional Block Diagrams (continued)

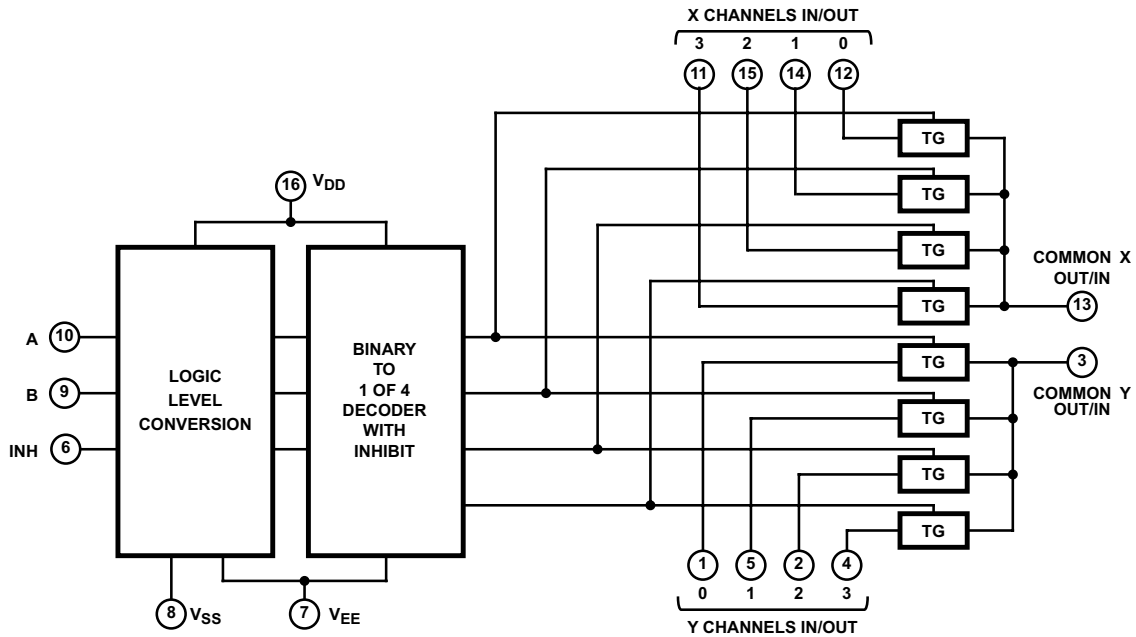

All inputs are protected by standard CMOS protection network.

Figure 27. Functional Block Diagram, CD4052B

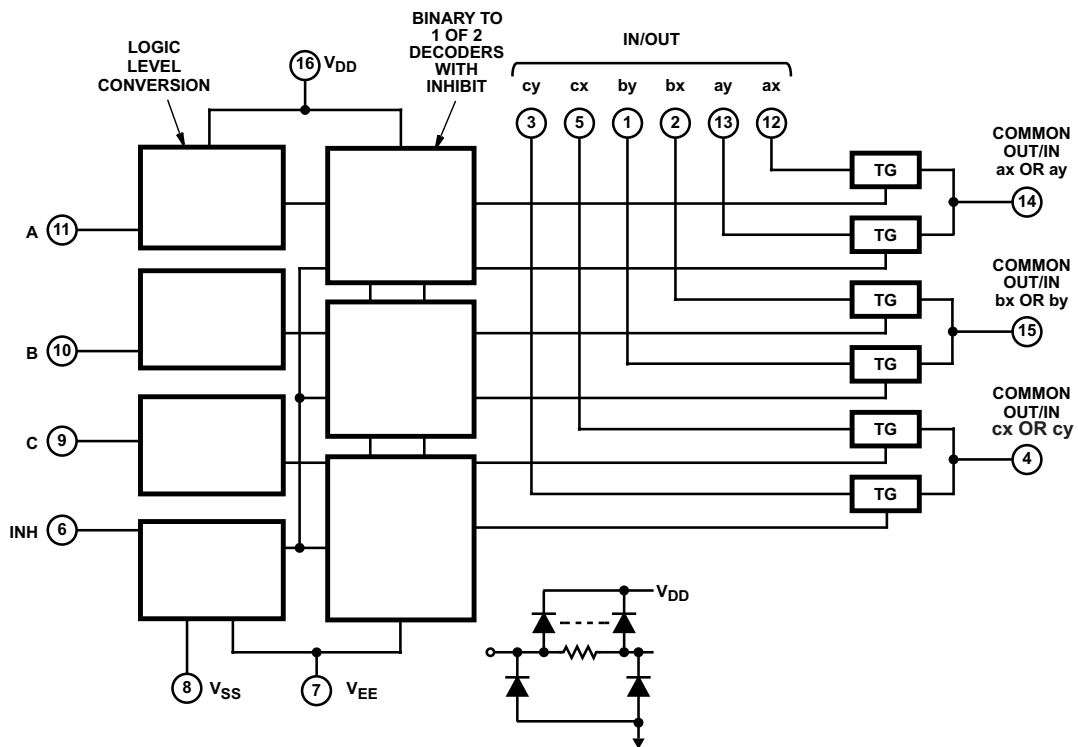

All inputs are protected by standard CMOS protection network.

Figure 28. Functional Block Diagram, CD4053B

8.3 Feature Description

The CD405xB line of multiplexers and demultiplexers can accept a wide range of digital and analog signal levels. Digital signals range from 3 V to 20 V, and analog signals are accepted at levels ≤ 20 V. They have low ON resistance, typically 125Ω over $15 V_{P-P}$ signal input range for $V_{DD} - V_{EE} = 18$ V. This allows for very little signal loss through the switch. Matched switch characteristics are typically $r_{ON} = 5 \Omega$ for $V_{DD} - V_{EE} = 15$ V.

The CD405xB devices also have high OFF resistance, which keeps from wasting power when the switch is in the OFF position, with typical channel leakage of ± 100 pA at $V_{DD} - V_{EE} = 18$ V. Very low quiescent power dissipation under all digital-control input and supply conditions, typically $0.2 \mu W$ at $V_{DD} - V_{SS} = V_{DD} - V_{EE} = 10$ V keeps power consumption total very low. All devices have been 100% tested for quiescent current at 20 V with maximum input current of $1 \mu A$ at 18 V over the full package temperature range, and only 100 nA at 18 V and $25^\circ C$.

Logic-level conversion for digital addressing signals of 3 V to 20 V ($V_{DD} - V_{SS} = 3$ V to 20 V) to switch analog signals to $20 V_{P-P}$ ($V_{DD} - V_{EE} = 20$ V). Binary address decoding on chip makes channel selection easy. When channels are changed, a break-before-make system eliminates channel overlap.

8.4 Device Functional Modes

Table 1. Truth Table⁽¹⁾

INPUT STATES				ON CHANNEL(S)
INHIBIT	C	B	A	
CD4051B				
0	0	0	0	0
0	0	0	1	1
0	0	1	0	2
0	0	1	1	3
0	1	0	0	4
0	1	0	1	5
0	1	1	0	6
0	1	1	1	7
1	X	X	X	None
CD4052B				
0		0	0	0x, 0y
0		0	1	1x, 1y
0		1	0	2x, 2y
0		1	1	3x, 3y
1		X	X	None
CD4053B				
0	X	X	0	ax
0	X	X	1	ay
0	X	0	X	bx
0	X	1	X	by
0	0	X	X	cx
0	1	X	X	cy
1	X	X	X	None

(1) X = Don't Care

9 Application and Implementation

NOTE

Information in the following applications sections is not part of the TI component specification, and TI does not warrant its accuracy or completeness. TI's customers are responsible for determining suitability of components for their purposes. Customers should validate and test their design implementation to confirm system functionality.

9.1 Application Information

The CD405xB multiplexers and demultiplexers can be used for a wide variety of applications.

9.2 Typical Application

One application of the CD4051B is to use it in conjunction with a microcontroller to poll a keypad. Figure 29 shows the basic schematic for such a polling system. The microcontroller uses the channel select pins to cycle through the different channels while reading the input to see if a user is pressing any of the keys. This is a very robust setup, allowing for multiple simultaneous key-presses with very little power consumption. It also uses very few pins on the microcontroller. The down side of polling is that the microcontroller must continually scan the keys for a press and can do little else during this process.

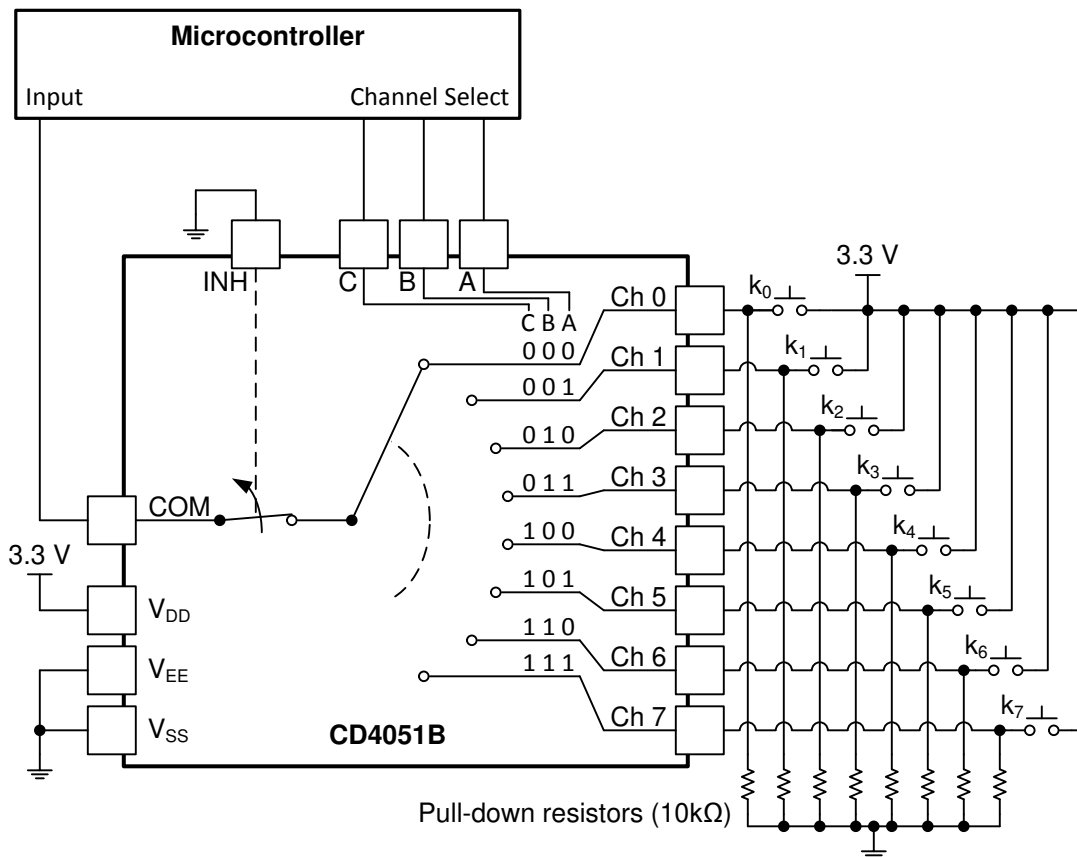

Figure 29. The CD4051B Being Used to Help Read Button Presses on a Keypad.

9.2.1 Design Requirements

These devices use CMOS technology and have balanced output drive. Take care to avoid bus contention because it can drive currents that would exceed maximum limits. The high drive will also create fast edges into light loads, so routing and load conditions should be considered to prevent ringing.

Typical Application (continued)

9.2.2 Detailed Design Procedure

1. Recommended Input Conditions
 - For switch time specifications, see propagation delay times in [Electrical Characteristics](#).
 - Inputs should not be pushed more than 0.5 V above V_{DD} or below V_{EE} .
 - For input voltage level specifications for control inputs, see V_{IH} and V_{IL} in [Electrical Characteristics](#).
2. Recommended Output Conditions
 - Outputs should not be pulled above V_{DD} or below V_{EE} .
3. Input/output current consideration: The CD405xB series of parts do not have internal current drive circuitry and thus cannot sink or source current. Any current will be passed through the device.

9.2.3 Application Curve

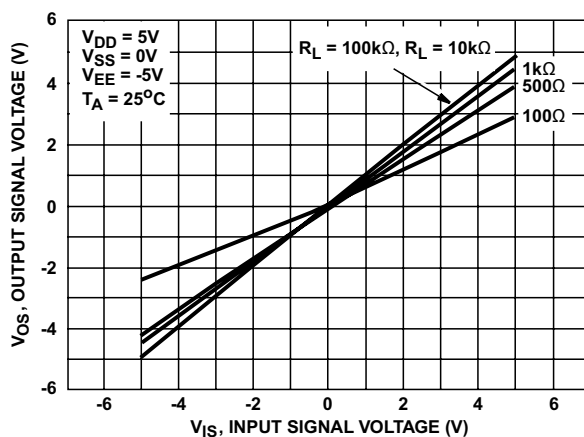

Figure 30. ON Characteristics for 1 of 8 Channels (CD4051B)

10 Power Supply Recommendations

The power supply can be any voltage between the minimum and maximum supply voltage rating located in the [Electrical Characteristics](#).

Each V_{CC} terminal should have a good bypass capacitor to prevent power disturbance. For devices with a single supply, a 0.1- μ F bypass capacitor is recommended. If there are multiple pins labeled V_{CC} , then a 0.01- μ F or 0.022- μ F capacitor is recommended for each V_{CC} because the V_{CC} pins will be tied together internally. For devices with dual supply pins operating at different voltages, for example V_{CC} and V_{DD} , a 0.1- μ F bypass capacitor is recommended for each supply pin. It is acceptable to parallel multiple bypass capacitors to reject different frequencies of noise. 0.1- μ F and 1- μ F capacitors are commonly used in parallel. The bypass capacitor should be installed as close to the power terminal as possible for best results.

11 Layout

11.1 Layout Guidelines

Reflections and matching are closely related to loop antenna theory, but different enough to warrant their own discussion. When a PCB trace turns a corner at a 90° angle, a reflection can occur. This is primarily due to the change of width of the trace. At the apex of the turn, the trace width is increased to 1.414 times its width. This upsets the transmission line characteristics, especially the distributed capacitance and self-inductance of the trace — resulting in the reflection. It is a given that not all PCB traces can be straight, and so they will have to turn corners. [Figure 31](#) shows progressively better techniques of rounding corners. Only the last example maintains constant trace width and minimizes reflections.

11.2 Layout Example

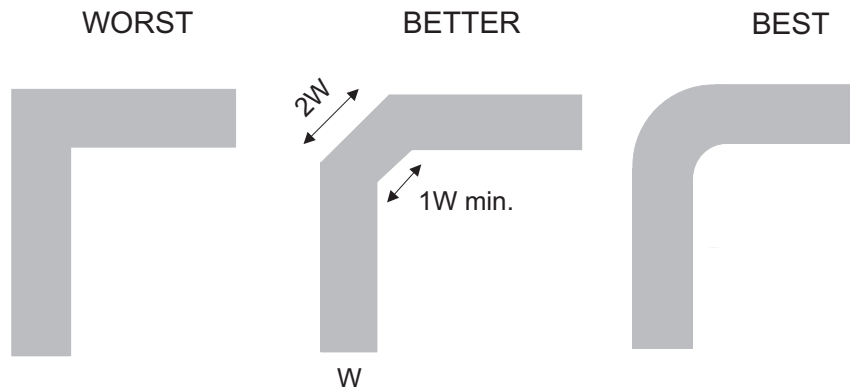

Figure 31. Trace Example

12 Device and Documentation Support

12.1 Documentation Support

12.1.1 Related Documentation

- *Implications of Slow or Floating CMOS Inputs*, [SCBA004](#)

12.2 Related Links

The table below lists quick access links. Categories include technical documents, support and community resources, tools and software, and quick access to order now.

Table 2. Related Links

PARTS	PRODUCT FOLDER	ORDER NOW	TECHNICAL DOCUMENTS	TOOLS & SOFTWARE	SUPPORT & COMMUNITY
CD4051B	Click here	Click here	Click here	Click here	Click here
CD4052B	Click here	Click here	Click here	Click here	Click here
CD4053B	Click here	Click here	Click here	Click here	Click here

12.3 Receiving Notification of Documentation Updates

To receive notification of documentation updates, navigate to the device product folder on ti.com. In the upper right corner, click on *Alert me* to register and receive a weekly digest of any product information that has changed. For change details, review the revision history included in any revised document.

12.4 Community Resources

[TI E2E™ support forums](#) are an engineer's go-to source for fast, verified answers and design help — straight from the experts. Search existing answers or ask your own question to get the quick design help you need.

Linked content is provided "AS IS" by the respective contributors. They do not constitute TI specifications and do not necessarily reflect TI's views; see TI's [Terms of Use](#).

12.5 Trademarks

E2E is a trademark of Texas Instruments.

All other trademarks are the property of their respective owners.

12.6 Electrostatic Discharge Caution



These devices have limited built-in ESD protection. The leads should be shorted together or the device placed in conductive foam during storage or handling to prevent electrostatic damage to the MOS gates.

12.7 Glossary

[SLYZ022](#) — *TI Glossary*.

This glossary lists and explains terms, acronyms, and definitions.

13 Mechanical, Packaging, and Orderable Information

The following pages include mechanical, packaging, and orderable information. This information is the most current data available for the designated devices. This data is subject to change without notice and revision of this document. For browser-based versions of this data sheet, refer to the left-hand navigation.

PACKAGING INFORMATION

Orderable Device	Status (1)	Package Type	Package Drawing	Pins	Package Qty	Eco Plan (2)	Lead finish/ Ball material (6)	MSL Peak Temp (3)	Op Temp (°C)	Device Marking (4/5)	Samples
7901502EA	ACTIVE	CDIP	J	16	1	Non-RoHS & Green	SNPB	N / A for Pkg Type	-55 to 125	7901502EA CD4052BF3A	Samples
8101801EA	ACTIVE	CDIP	J	16	1	Non-RoHS & Green	SNPB	N / A for Pkg Type	-55 to 125	8101801EA CD4053BF3A	Samples
CD4051BE	ACTIVE	PDIP	N	16	25	RoHS & Green	NIPDAU SN	N / A for Pkg Type	-55 to 125	CD4051BE	Samples
CD4051BEE4	ACTIVE	PDIP	N	16	25	RoHS & Green	NIPDAU	N / A for Pkg Type	-55 to 125	CD4051BE	Samples
CD4051BF	ACTIVE	CDIP	J	16	1	Non-RoHS & Green	SNPB	N / A for Pkg Type	-55 to 125	CD4051BF	Samples
CD4051BF3A	ACTIVE	CDIP	J	16	1	Non-RoHS & Green	SNPB	N / A for Pkg Type	-55 to 125	CD4051BF3A	Samples
CD4051BM	ACTIVE	SOIC	D	16	40	RoHS & Green	NIPDAU	Level-1-260C-UNLIM	-55 to 125	CD4051BM	Samples
CD4051BM96	ACTIVE	SOIC	D	16	2500	RoHS & Green	NIPDAU SN	Level-1-260C-UNLIM	-55 to 125	CD4051BM	Samples
CD4051BM96G3	ACTIVE	SOIC	D	16	2500	RoHS & Green	SN	Level-1-260C-UNLIM	-55 to 125	CD4051BM	Samples
CD4051BM96G4	ACTIVE	SOIC	D	16	2500	RoHS & Green	NIPDAU	Level-1-260C-UNLIM	-55 to 125	CD4051BM	Samples
CD4051BMG4	ACTIVE	SOIC	D	16	40	RoHS & Green	NIPDAU	Level-1-260C-UNLIM	-55 to 125	CD4051BM	Samples
CD4051BMT	ACTIVE	SOIC	D	16	250	RoHS & Green	NIPDAU	Level-1-260C-UNLIM	-55 to 125	CD4051BM	Samples
CD4051BNSR	ACTIVE	SO	NS	16	2000	RoHS & Green	NIPDAU	Level-1-260C-UNLIM	-55 to 125	CD4051B	Samples
CD4051BNSRE4	ACTIVE	SO	NS	16	2000	TBD	Call TI	Call TI	-55 to 125		Samples
CD4051BPW	ACTIVE	TSSOP	PW	16	90	RoHS & Green	NIPDAU	Level-1-260C-UNLIM	-55 to 125	CM051B	Samples
CD4051BPWE4	ACTIVE	TSSOP	PW	16	90	RoHS & Green	NIPDAU	Level-1-260C-UNLIM	-55 to 125	CM051B	Samples
CD4051BPWR	ACTIVE	TSSOP	PW	16	2000	RoHS & Green	NIPDAU SN	Level-1-260C-UNLIM	-55 to 125	CM051B	Samples
CD4051BPWRG4	ACTIVE	TSSOP	PW	16	2000	RoHS & Green	NIPDAU	Level-1-260C-UNLIM	-55 to 125	CM051B	Samples
CD4052BE	ACTIVE	PDIP	N	16	25	RoHS & Green	NIPDAU SN	N / A for Pkg Type	-55 to 125	CD4052BE	Samples

Orderable Device	Status (1)	Package Type	Package Drawing	Pins	Package Qty	Eco Plan (2)	Lead finish/ Ball material (6)	MSL Peak Temp (3)	Op Temp (°C)	Device Marking (4/5)	Samples
CD4052BEE4	ACTIVE	PDIP	N	16	25	RoHS & Non-Green	NIPDAU	N / A for Pkg Type	-55 to 125	CD4052BE	Samples
CD4052BF	ACTIVE	CDIP	J	16	1	Non-RoHS & Green	SNPB	N / A for Pkg Type	-55 to 125	CD4052BF	Samples
CD4052BF3A	ACTIVE	CDIP	J	16	1	Non-RoHS & Green	SNPB	N / A for Pkg Type	-55 to 125	7901502EA CD4052BF3A	Samples
CD4052BM	ACTIVE	SOIC	D	16	40	RoHS & Green	NIPDAU	Level-1-260C-UNLIM	-55 to 125	CD4052BM	Samples
CD4052BM96	ACTIVE	SOIC	D	16	2500	RoHS & Green	NIPDAU SN	Level-1-260C-UNLIM	-55 to 125	CD4052BM	Samples
CD4052BM96G3	ACTIVE	SOIC	D	16	2500	RoHS & Green	SN	Level-1-260C-UNLIM	-55 to 125	CD4052BM	Samples
CD4052BM96G4	ACTIVE	SOIC	D	16	2500	RoHS & Green	NIPDAU	Level-1-260C-UNLIM	-55 to 125	CD4052BM	Samples
CD4052BMG4	ACTIVE	SOIC	D	16	40	RoHS & Green	NIPDAU	Level-1-260C-UNLIM	-55 to 125	CD4052BM	Samples
CD4052BMT	ACTIVE	SOIC	D	16	250	RoHS & Green	NIPDAU	Level-1-260C-UNLIM	-55 to 125	CD4052BM	Samples
CD4052BNSR	ACTIVE	SO	NS	16	2000	RoHS & Green	NIPDAU	Level-1-260C-UNLIM	-55 to 125	CD4052B	Samples
CD4052BPW	ACTIVE	TSSOP	PW	16	90	RoHS & Green	NIPDAU	Level-1-260C-UNLIM	-55 to 125	CM052B	Samples
CD4052BPWR	ACTIVE	TSSOP	PW	16	2000	RoHS & Green	NIPDAU SN	Level-1-260C-UNLIM	-55 to 125	CM052B	Samples
CD4052BPWRG3	ACTIVE	TSSOP	PW	16	2000	RoHS & Green	SN	Level-1-260C-UNLIM	-55 to 125	CM052B	Samples
CD4052BPWRG4	ACTIVE	TSSOP	PW	16	2000	RoHS & Green	NIPDAU	Level-1-260C-UNLIM	-55 to 125	CM052B	Samples
CD4053BE	ACTIVE	PDIP	N	16	25	RoHS & Green	NIPDAU	N / A for Pkg Type	-55 to 125	CD4053BE	Samples
CD4053BEE4	ACTIVE	PDIP	N	16	25	RoHS & Green	NIPDAU	N / A for Pkg Type	-55 to 125	CD4053BE	Samples
CD4053BF	ACTIVE	CDIP	J	16	1	Non-RoHS & Green	SNPB	N / A for Pkg Type	-55 to 125	CD4053BF	Samples
CD4053BF3A	ACTIVE	CDIP	J	16	1	Non-RoHS & Green	SNPB	N / A for Pkg Type	-55 to 125	8101801EA CD4053BF3A	Samples
CD4053BM	ACTIVE	SOIC	D	16	40	RoHS & Green	NIPDAU	Level-1-260C-UNLIM	-55 to 125	CD4053M	Samples
CD4053BM96	ACTIVE	SOIC	D	16	2500	RoHS & Green	NIPDAU SN	Level-1-260C-UNLIM	-55 to 125	CD4053M	Samples

Orderable Device	Status (1)	Package Type	Package Drawing	Pins	Package Qty	Eco Plan (2)	Lead finish/ Ball material (6)	MSL Peak Temp (3)	Op Temp (°C)	Device Marking (4/5)	Samples
CD4053BM96E4	ACTIVE	SOIC	D	16	2500	RoHS & Green	NIPDAU	Level-1-260C-UNLIM	-55 to 125	CD4053M	Samples
CD4053BM96G3	ACTIVE	SOIC	D	16	2500	RoHS & Green	SN	Level-1-260C-UNLIM	-55 to 125	CD4053M	Samples
CD4053BM96G4	ACTIVE	SOIC	D	16	2500	RoHS & Green	NIPDAU	Level-1-260C-UNLIM	-55 to 125	CD4053M	Samples
CD4053BMG4	ACTIVE	SOIC	D	16	40	RoHS & Green	NIPDAU	Level-1-260C-UNLIM	-55 to 125	CD4053M	Samples
CD4053BMT	ACTIVE	SOIC	D	16	250	RoHS & Green	NIPDAU	Level-1-260C-UNLIM	-55 to 125	CD4053M	Samples
CD4053BNSR	ACTIVE	SO	NS	16	2000	RoHS & Green	NIPDAU	Level-1-260C-UNLIM	-55 to 125	CD4053B	Samples
CD4053BPW	ACTIVE	TSSOP	PW	16	90	RoHS & Green	NIPDAU	Level-1-260C-UNLIM	-55 to 125	CM053B	Samples
CD4053BPWR	ACTIVE	TSSOP	PW	16	2000	RoHS & Green	NIPDAU SN	Level-1-260C-UNLIM	-55 to 125	CM053B	Samples
CD4053BPWRG3	ACTIVE	TSSOP	PW	16	2000	RoHS & Green	SN	Level-1-260C-UNLIM	-55 to 125	CM053B	Samples
CD4053BPWRG4	ACTIVE	TSSOP	PW	16	2000	RoHS & Green	NIPDAU	Level-1-260C-UNLIM	-55 to 125	CM053B	Samples

(1) The marketing status values are defined as follows:

ACTIVE: Product device recommended for new designs.

LIFEBUY: TI has announced that the device will be discontinued, and a lifetime-buy period is in effect.

NRND: Not recommended for new designs. Device is in production to support existing customers, but TI does not recommend using this part in a new design.

PREVIEW: Device has been announced but is not in production. Samples may or may not be available.

OBSOLETE: TI has discontinued the production of the device.

(2) **RoHS:** TI defines "RoHS" to mean semiconductor products that are compliant with the current EU RoHS requirements for all 10 RoHS substances, including the requirement that RoHS substance do not exceed 0.1% by weight in homogeneous materials. Where designed to be soldered at high temperatures, "RoHS" products are suitable for use in specified lead-free processes. TI may reference these types of products as "Pb-Free".

RoHS Exempt: TI defines "RoHS Exempt" to mean products that contain lead but are compliant with EU RoHS pursuant to a specific EU RoHS exemption.

Green: TI defines "Green" to mean the content of Chlorine (Cl) and Bromine (Br) based flame retardants meet JS709B low halogen requirements of <=1000ppm threshold. Antimony trioxide based flame retardants must also meet the <=1000ppm threshold requirement.

(3) MSL, Peak Temp. - The Moisture Sensitivity Level rating according to the JEDEC industry standard classifications, and peak solder temperature.

(4) There may be additional marking, which relates to the logo, the lot trace code information, or the environmental category on the device.

(5) Multiple Device Markings will be inside parentheses. Only one Device Marking contained in parentheses and separated by a "~" will appear on a device. If a line is indented then it is a continuation of the previous line and the two combined represent the entire Device Marking for that device.

(6) Lead finish/Ball material - Orderable Devices may have multiple material finish options. Finish options are separated by a vertical ruled line. Lead finish/Ball material values may wrap to two lines if the finish value exceeds the maximum column width.

Important Information and Disclaimer:The information provided on this page represents TI's knowledge and belief as of the date that it is provided. TI bases its knowledge and belief on information provided by third parties, and makes no representation or warranty as to the accuracy of such information. Efforts are underway to better integrate information from third parties. TI has taken and continues to take reasonable steps to provide representative and accurate information but may not have conducted destructive testing or chemical analysis on incoming materials and chemicals. TI and TI suppliers consider certain information to be proprietary, and thus CAS numbers and other limited information may not be available for release.

In no event shall TI's liability arising out of such information exceed the total purchase price of the TI part(s) at issue in this document sold by TI to Customer on an annual basis.

OTHER QUALIFIED VERSIONS OF CD4051B, CD4051B-MIL, CD4052B, CD4052B-MIL, CD4053B, CD4053B-MIL :

- Catalog : [CD4051B](#), [CD4052B](#), [CD4053B](#)

- Automotive : [CD4051B-Q1](#), [CD4051B-Q1](#), [CD4053B-Q1](#), [CD4053B-Q1](#)

- Military : [CD4051B-MIL](#), [CD4052B-MIL](#), [CD4053B-MIL](#)

NOTE: Qualified Version Definitions:

- Catalog - TI's standard catalog product

- Automotive - Q100 devices qualified for high-reliability automotive applications targeting zero defects

- Military - QML certified for Military and Defense Applications

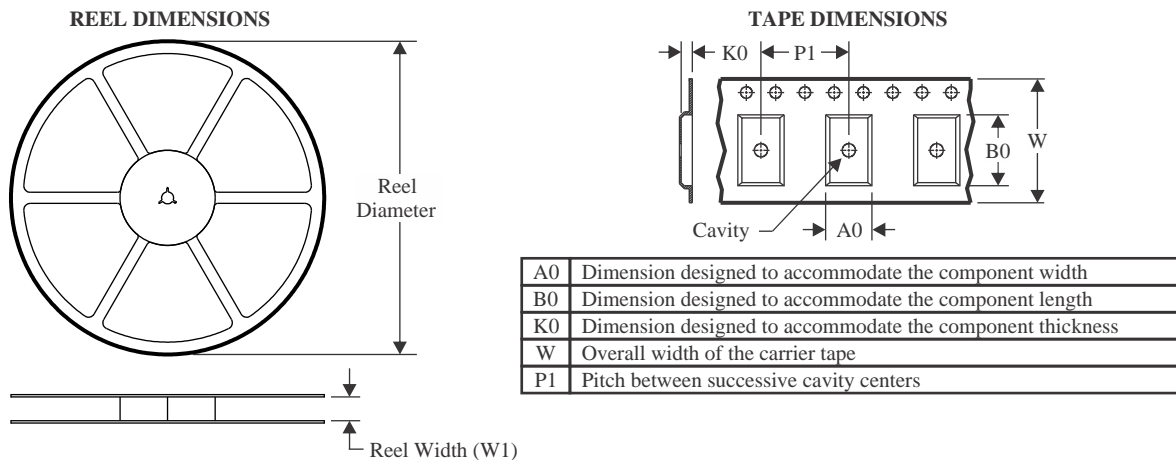
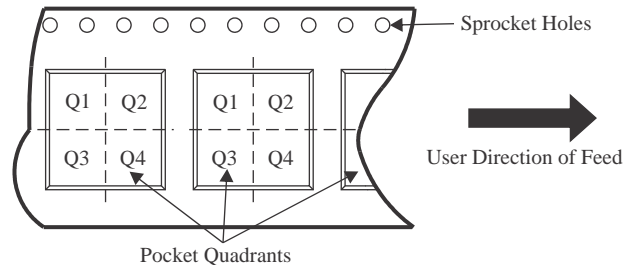
TAPE AND REEL INFORMATION

QUADRANT ASSIGNMENTS FOR PIN 1 ORIENTATION IN TAPE

*All dimensions are nominal

Device	Package Type	Package Drawing	Pins	SPQ	Reel Diameter (mm)	Reel Width W1 (mm)	A0 (mm)	B0 (mm)	K0 (mm)	P1 (mm)	W (mm)	Pin1 Quadrant
CD4051BM96	SOIC	D	16	2500	330.0	16.4	6.5	10.3	2.1	8.0	16.0	Q1
CD4051BM96	SOIC	D	16	2500	330.0	16.4	6.5	10.3	2.1	8.0	16.0	Q1
CD4051BM96	SOIC	D	16	2500	330.0	16.8	6.5	10.3	2.1	8.0	16.0	Q1
CD4051BM96G3	SOIC	D	16	2500	330.0	16.8	6.5	10.3	2.1	8.0	16.0	Q1
CD4051BM96G4	SOIC	D	16	2500	330.0	16.4	6.5	10.3	2.1	8.0	16.0	Q1
CD4051BM96G4	SOIC	D	16	2500	330.0	16.4	6.5	10.3	2.1	8.0	16.0	Q1
CD4051BNSR	SO	NS	16	2000	330.0	16.4	8.2	10.5	2.5	12.0	16.0	Q1
CD4051BPWR	TSSOP	PW	16	2000	330.0	12.4	6.9	5.6	1.6	8.0	12.0	Q1
CD4051BPWR	TSSOP	PW	16	2000	330.0	12.4	6.9	5.6	1.6	8.0	12.0	Q1
CD4051BPWRG4	TSSOP	PW	16	2000	330.0	12.4	6.9	5.6	1.6	8.0	12.0	Q1
CD4052BM96	SOIC	D	16	2500	330.0	16.4	6.5	10.3	2.1	8.0	16.0	Q1
CD4052BM96	SOIC	D	16	2500	330.0	16.8	6.5	10.3	2.1	8.0	16.0	Q1
CD4052BM96G3	SOIC	D	16	2500	330.0	16.8	6.5	10.3	2.1	8.0	16.0	Q1
CD4052BM96G4	SOIC	D	16	2500	330.0	16.4	6.5	10.3	2.1	8.0	16.0	Q1
CD4052BNSR	SO	NS	16	2000	330.0	16.4	8.2	10.5	2.5	12.0	16.0	Q1
CD4052BPWR	TSSOP	PW	16	2000	330.0	12.4	6.9	5.6	1.6	8.0	12.0	Q1

Device	Package Type	Package Drawing	Pins	SPQ	Reel Diameter (mm)	Reel Width W1 (mm)	A0 (mm)	B0 (mm)	K0 (mm)	P1 (mm)	W (mm)	Pin1 Quadrant
CD4052BPWR	TSSOP	PW	16	2000	330.0	12.4	6.9	5.6	1.6	8.0	12.0	Q1
CD4052BPWRG3	TSSOP	PW	16	2000	330.0	12.4	6.9	5.6	1.6	8.0	12.0	Q1
CD4052BPWRG4	TSSOP	PW	16	2000	330.0	12.4	6.9	5.6	1.6	8.0	12.0	Q1
CD4053BM96	SOIC	D	16	2500	330.0	16.8	6.5	10.3	2.1	8.0	16.0	Q1
CD4053BM96	SOIC	D	16	2500	330.0	16.4	6.5	10.3	2.1	8.0	16.0	Q1
CD4053BM96G3	SOIC	D	16	2500	330.0	16.8	6.5	10.3	2.1	8.0	16.0	Q1
CD4053BM96G4	SOIC	D	16	2500	330.0	16.4	6.5	10.3	2.1	8.0	16.0	Q1
CD4053BNSR	SO	NS	16	2000	330.0	16.4	8.2	10.5	2.5	12.0	16.0	Q1
CD4053BPWR	TSSOP	PW	16	2000	330.0	12.4	6.9	5.6	1.6	8.0	12.0	Q1
CD4053BPWR	TSSOP	PW	16	2000	330.0	12.4	6.9	5.6	1.6	8.0	12.0	Q1
CD4053BPWRG3	TSSOP	PW	16	2000	330.0	12.4	6.9	5.6	1.6	8.0	12.0	Q1
CD4053BPWRG4	TSSOP	PW	16	2000	330.0	12.4	6.9	5.6	1.6	8.0	12.0	Q1

TAPE AND REEL BOX DIMENSIONS

*All dimensions are nominal

Device	Package Type	Package Drawing	Pins	SPQ	Length (mm)	Width (mm)	Height (mm)
CD4051BM96	SOIC	D	16	2500	356.0	356.0	35.0
CD4051BM96	SOIC	D	16	2500	340.5	336.1	32.0
CD4051BM96	SOIC	D	16	2500	364.0	364.0	27.0
CD4051BM96G3	SOIC	D	16	2500	364.0	364.0	27.0
CD4051BM96G4	SOIC	D	16	2500	356.0	356.0	35.0
CD4051BM96G4	SOIC	D	16	2500	340.5	336.1	32.0
CD4051BNSR	SO	NS	16	2000	356.0	356.0	35.0
CD4051BPWR	TSSOP	PW	16	2000	367.0	367.0	35.0
CD4051BPWR	TSSOP	PW	16	2000	364.0	364.0	27.0
CD4051BPWRG4	TSSOP	PW	16	2000	367.0	367.0	35.0
CD4052BM96	SOIC	D	16	2500	340.5	336.1	32.0
CD4052BM96	SOIC	D	16	2500	364.0	364.0	27.0
CD4052BM96G3	SOIC	D	16	2500	364.0	364.0	27.0
CD4052BM96G4	SOIC	D	16	2500	340.5	336.1	32.0
CD4052BNSR	SO	NS	16	2000	356.0	356.0	35.0
CD4052BPWR	TSSOP	PW	16	2000	367.0	367.0	35.0
CD4052BPWR	TSSOP	PW	16	2000	364.0	364.0	27.0
CD4052BPWRG3	TSSOP	PW	16	2000	364.0	364.0	27.0

Device	Package Type	Package Drawing	Pins	SPQ	Length (mm)	Width (mm)	Height (mm)
CD4052BPWRG4	TSSOP	PW	16	2000	367.0	367.0	35.0
CD4053BM96	SOIC	D	16	2500	364.0	364.0	27.0
CD4053BM96	SOIC	D	16	2500	340.5	336.1	32.0
CD4053BM96G3	SOIC	D	16	2500	364.0	364.0	27.0
CD4053BM96G4	SOIC	D	16	2500	340.5	336.1	32.0
CD4053BNSR	SO	NS	16	2000	356.0	356.0	35.0
CD4053BPWR	TSSOP	PW	16	2000	367.0	367.0	35.0
CD4053BPWR	TSSOP	PW	16	2000	364.0	364.0	27.0
CD4053BPWRG3	TSSOP	PW	16	2000	364.0	364.0	27.0
CD4053BPWRG4	TSSOP	PW	16	2000	367.0	367.0	35.0

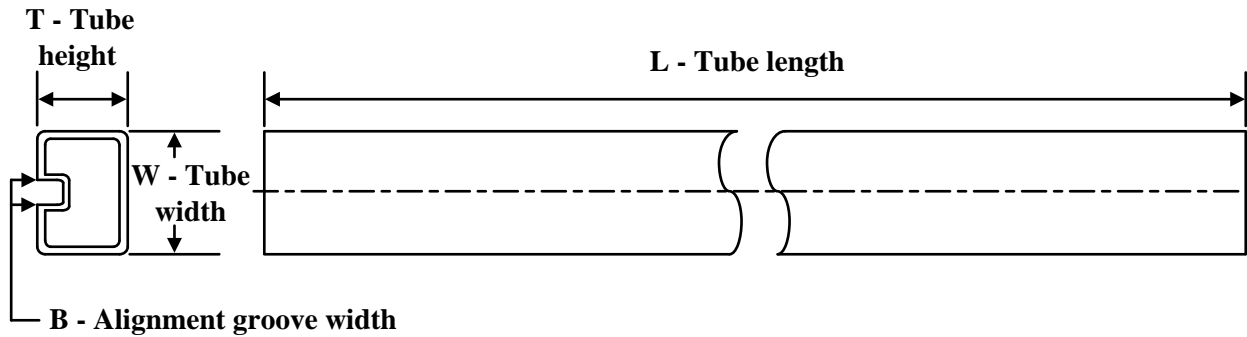
TUBE

*All dimensions are nominal



Device	Package Name	Package Type	Pins	SPQ	L (mm)	W (mm)	T (µm)	B (mm)
CD4051BE	N	PDIP	16	25	506	13.97	11230	4.32
CD4051BE	N	PDIP	16	25	506.1	9	600	5.4
CD4051BE	N	PDIP	16	25	506	13.97	11230	4.32
CD4051BEE4	N	PDIP	16	25	506	13.97	11230	4.32
CD4051BEE4	N	PDIP	16	25	506	13.97	11230	4.32
CD4051BM	D	SOIC	16	40	506.6	8	3940	4.32
CD4051BM	D	SOIC	16	40	507	8	3940	4.32
CD4051BMG4	D	SOIC	16	40	507	8	3940	4.32
CD4051BMG4	D	SOIC	16	40	506.6	8	3940	4.32
CD4051BPW	PW	TSSOP	16	90	530	10.2	3600	3.5
CD4051BPWE4	PW	TSSOP	16	90	530	10.2	3600	3.5
CD4052BE	N	PDIP	16	25	506	13.97	11230	4.32
CD4052BE	N	PDIP	16	25	506	13.97	11230	4.32
CD4052BE	N	PDIP	16	25	506.1	9	600	5.4
CD4052BEE4	N	PDIP	16	25	506.1	9	600	5.4
CD4052BEE4	N	PDIP	16	25	506	13.97	11230	4.32
CD4052BEE4	N	PDIP	16	25	506	13.97	11230	4.32
CD4052BM	D	SOIC	16	40	507	8	3940	4.32
CD4052BMG4	D	SOIC	16	40	507	8	3940	4.32
CD4052BPW	PW	TSSOP	16	90	530	10.2	3600	3.5
CD4053BE	N	PDIP	16	25	506	13.97	11230	4.32
CD4053BE	N	PDIP	16	25	506	13.97	11230	4.32
CD4053BEE4	N	PDIP	16	25	506	13.97	11230	4.32
CD4053BEE4	N	PDIP	16	25	506	13.97	11230	4.32
CD4053BM	D	SOIC	16	40	507	8	3940	4.32
CD4053BMG4	D	SOIC	16	40	507	8	3940	4.32
CD4053BPW	PW	TSSOP	16	90	530	10.2	3600	3.5

D (R-PDSO-G16)

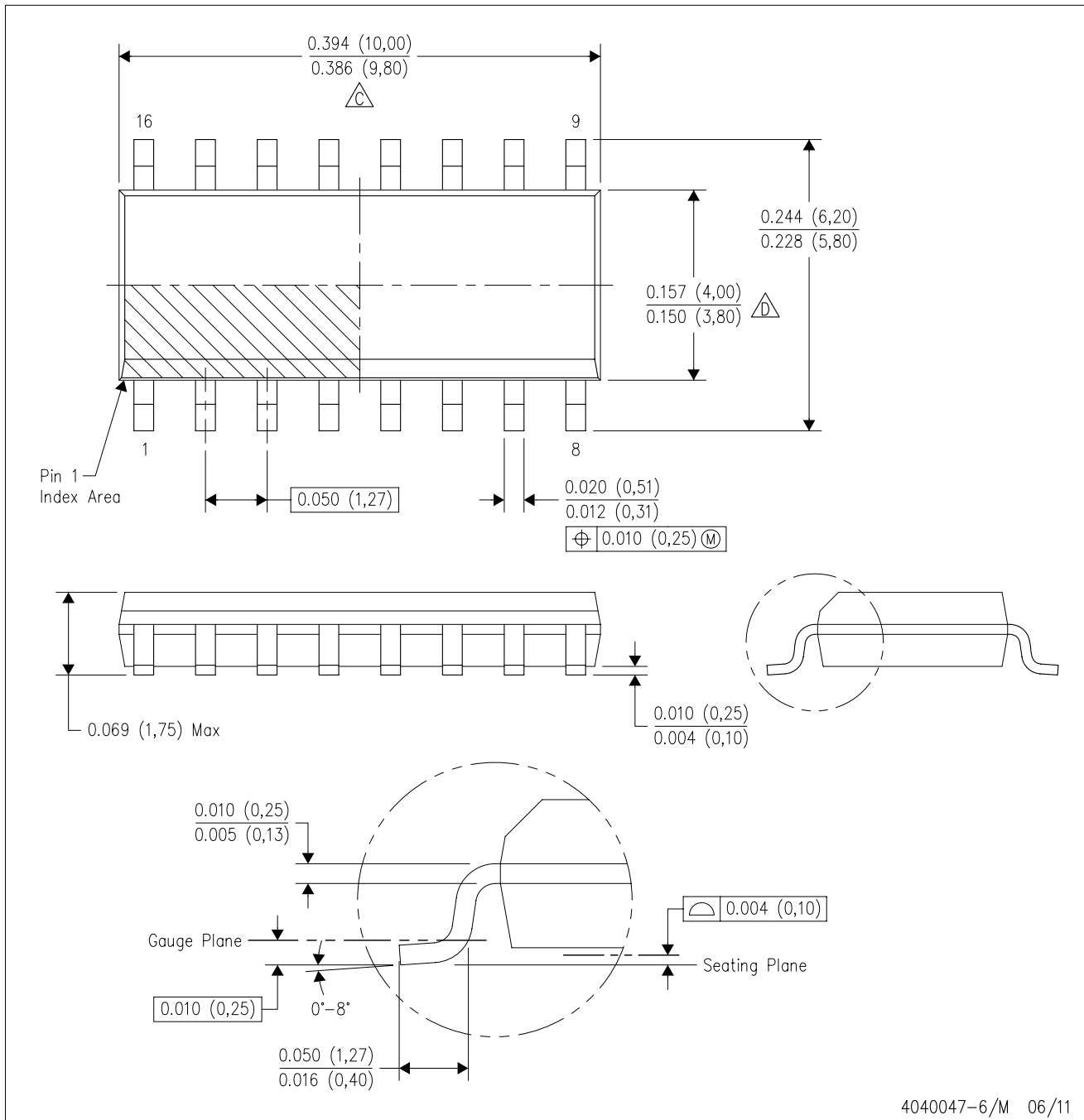
PLASTIC SMALL OUTLINE



4040047-6/M 06/11

- NOTES:
- A. All linear dimensions are in inches (millimeters).
 - B. This drawing is subject to change without notice.
 -  C. Body length does not include mold flash, protrusions, or gate burrs. Mold flash, protrusions, or gate burrs shall not exceed 0.006 (0,15) each side.
 -  D. Body width does not include interlead flash. Interlead flash shall not exceed 0.017 (0,43) each side.
 - E. Reference JEDEC MS-012 variation AC.

D (R-PDSO-G16)

PLASTIC SMALL OUTLINE

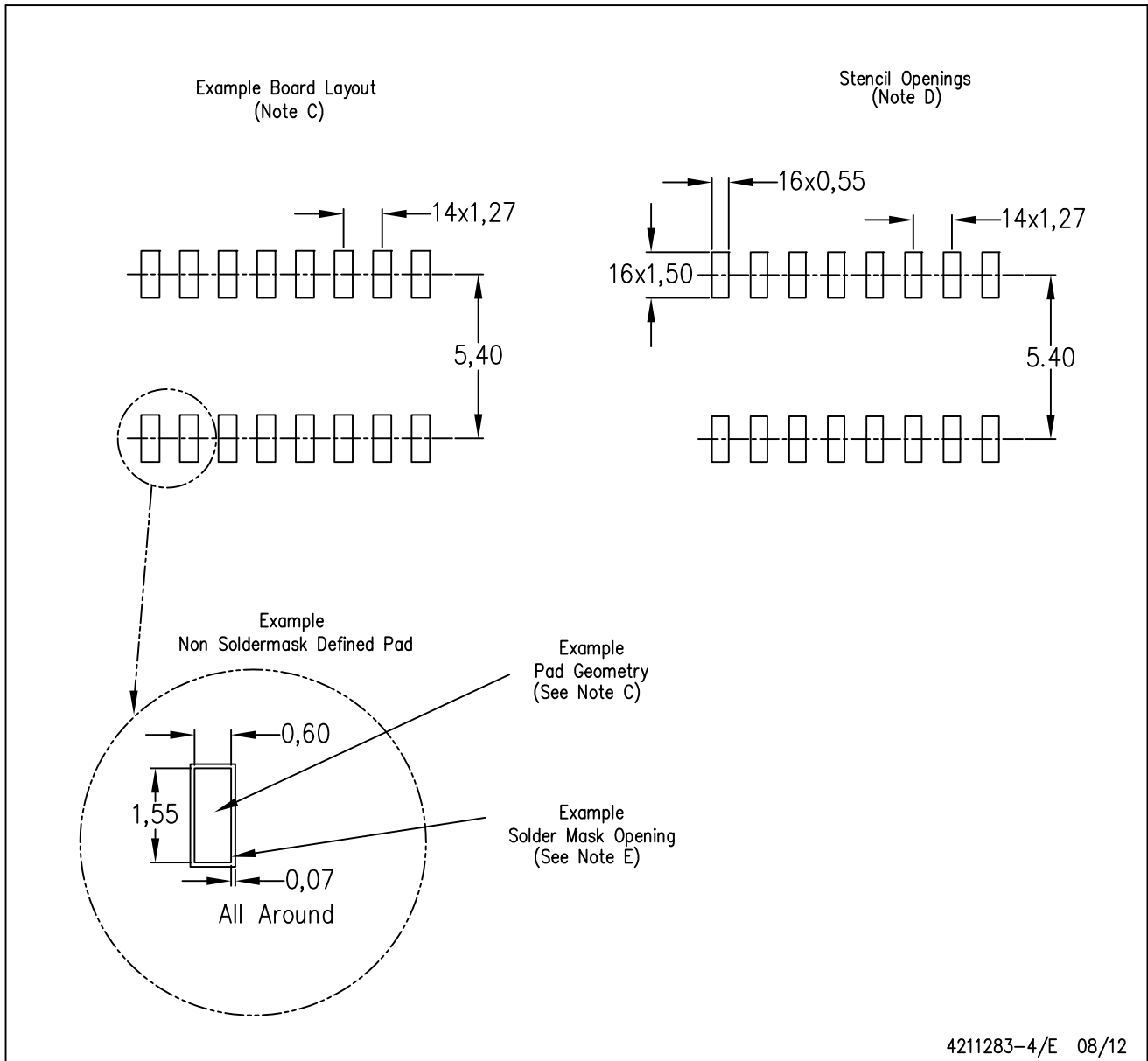

4211283-4/E 08/12

- NOTES:
- All linear dimensions are in millimeters.
 - This drawing is subject to change without notice.
 - Publication IPC-7351 is recommended for alternate designs.
 - Laser cutting apertures with trapezoidal walls and also rounding corners will offer better paste release. Customers should contact their board assembly site for stencil design recommendations. Refer to IPC-7525 for other stencil recommendations.
 - Customers should contact their board fabrication site for solder mask tolerances between and around signal pads.



4220204/A 02/2017

NOTES:

1. All linear dimensions are in millimeters. Any dimensions in parenthesis are for reference only. Dimensioning and tolerancing per ASME Y14.5M.
2. This drawing is subject to change without notice.
3. This dimension does not include mold flash, protrusions, or gate burrs. Mold flash, protrusions, or gate burrs shall not exceed 0.15 mm per side.
4. This dimension does not include interlead flash. Interlead flash shall not exceed 0.25 mm per side.
5. Reference JEDEC registration MO-153.

EXAMPLE BOARD LAYOUT

PW0016A

TSSOP - 1.2 mm max height

SMALL OUTLINE PACKAGE



LAND PATTERN EXAMPLE
EXPOSED METAL SHOWN
SCALE: 10X



4220204/A 02/2017

NOTES: (continued)

- 6. Publication IPC-7351 may have alternate designs.
- 7. Solder mask tolerances between and around signal pads can vary based on board fabrication site.

EXAMPLE STENCIL DESIGN

PW0016A

TSSOP - 1.2 mm max height

SMALL OUTLINE PACKAGE



SOLDER PASTE EXAMPLE
BASED ON 0.125 mm THICK STENCIL
SCALE: 10X

4220204/A 02/2017

NOTES: (continued)

8. Laser cutting apertures with trapezoidal walls and rounded corners may offer better paste release. IPC-7525 may have alternate design recommendations.
9. Board assembly site may have different recommendations for stencil design.

MECHANICAL DATA

NS (R-PDSO-G**)

PLASTIC SMALL-OUTLINE PACKAGE

14-PINS SHOWN



- NOTES:
- A. All linear dimensions are in millimeters.
 - B. This drawing is subject to change without notice.
 - C. Body dimensions do not include mold flash or protrusion, not to exceed 0,15.

J (R-GDIP-T**)

14 LEADS SHOWN

CERAMIC DUAL IN-LINE PACKAGE

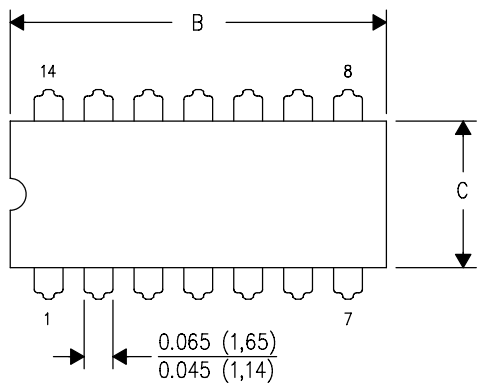

DIM \ PINS **	14	16	18	20
A	0.300 (7,62) BSC	0.300 (7,62) BSC	0.300 (7,62) BSC	0.300 (7,62) BSC
B MAX	0.785 (19,94)	.840 (21,34)	0.960 (24,38)	1.060 (26,92)
B MIN	—	—	—	—
C MAX	0.300 (7,62)	0.300 (7,62)	0.310 (7,87)	0.300 (7,62)
C MIN	0.245 (6,22)	0.245 (6,22)	0.220 (5,59)	0.245 (6,22)

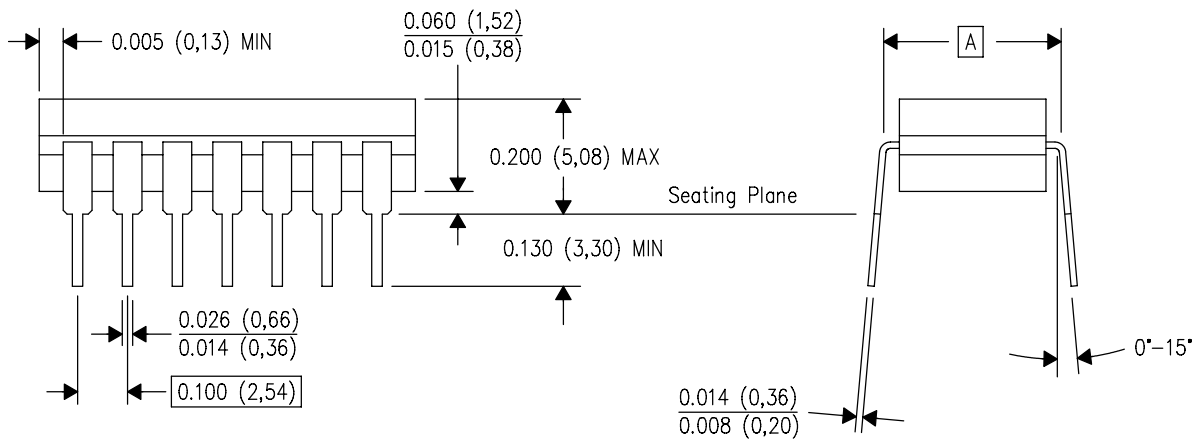

4040083/F 03/03

- NOTES:
- All linear dimensions are in inches (millimeters).
 - This drawing is subject to change without notice.
 - This package is hermetically sealed with a ceramic lid using glass frit.
 - Index point is provided on cap for terminal identification only on press ceramic glass frit seal only.
 - Falls within MIL STD 1835 GDIP1-T14, GDIP1-T16, GDIP1-T18 and GDIP1-T20.

N (R-PDIP-T**)

PLASTIC DUAL-IN-LINE PACKAGE

16 PINS SHOWN



- NOTES:
- A. All linear dimensions are in inches (millimeters).
 - B. This drawing is subject to change without notice.
 - Falls within JEDEC MS-001, except 18 and 20 pin minimum body length (Dim A).
 - The 20 pin end lead shoulder width is a vendor option, either half or full width.

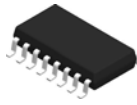

PACKAGE OUTLINE

NS0016A

SOP - 2.00 mm max height

SOP

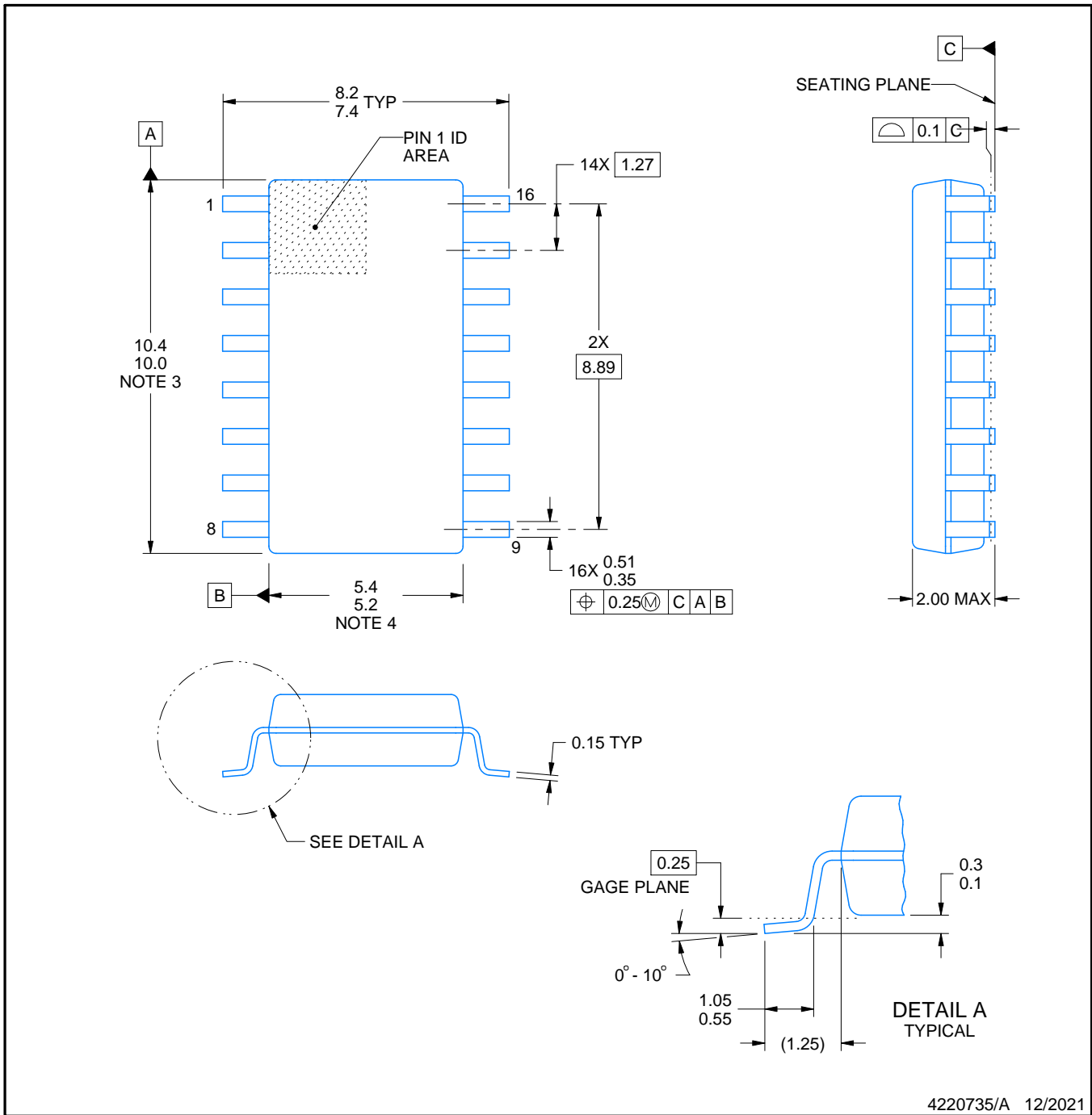

NOTES:

1. All linear dimensions are in millimeters. Dimensions in parenthesis are for reference only. Dimensioning and tolerancing per ASME Y14.5M.
2. This drawing is subject to change without notice.
3. This dimension does not include mold flash, protrusions, or gate burrs. Mold flash, protrusions, or gate burrs shall not exceed 0.15 mm, per side.
4. This dimension does not include interlead flash. Interlead flash shall not exceed 0.25 mm, per side.

EXAMPLE BOARD LAYOUT

NS0016A

SOP - 2.00 mm max height

SOP

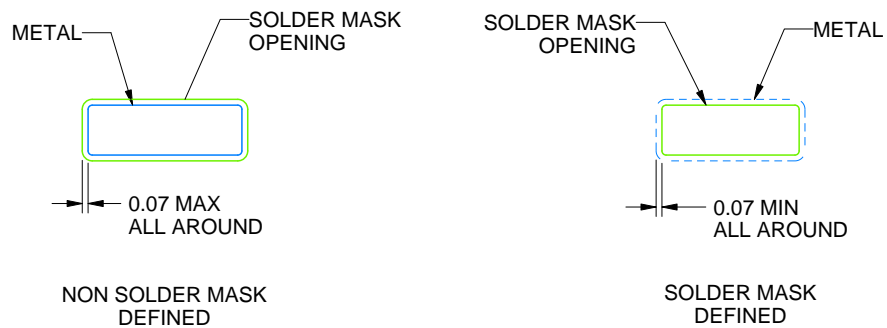
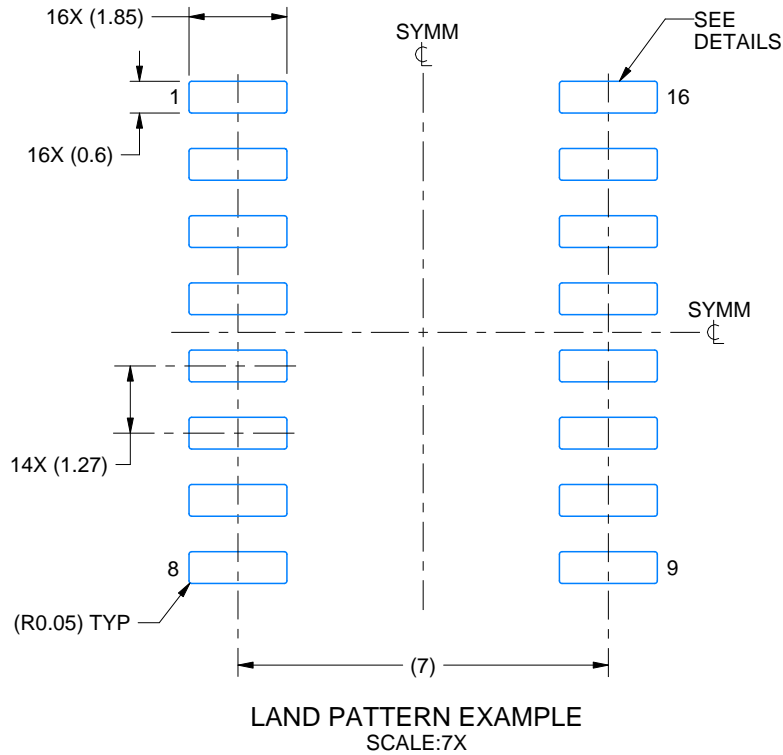

SOLDER MASK DETAILS

4220735/A 12/2021

NOTES: (continued)

5. Publication IPC-7351 may have alternate designs.

6. Solder mask tolerances between and around signal pads can vary based on board fabrication site.

EXAMPLE STENCIL DESIGN

NS0016A

SOP - 2.00 mm max height

SOP

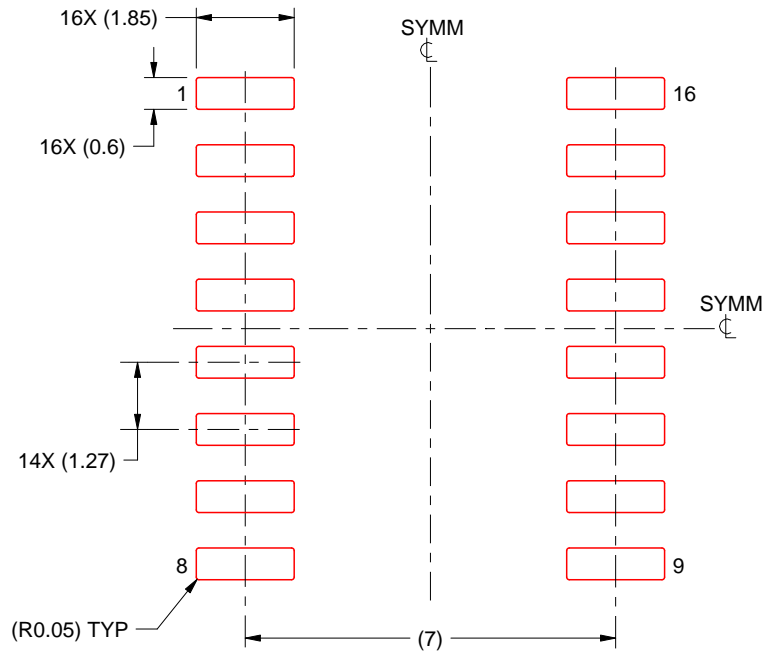

SOLDER PASTE EXAMPLE
BASED ON 0.125 mm THICK STENCIL
SCALE:7X

4220735/A 12/2021

NOTES: (continued)

7. Laser cutting apertures with trapezoidal walls and rounded corners may offer better paste release. IPC-7525 may have alternate design recommendations.
8. Board assembly site may have different recommendations for stencil design.

IMPORTANT NOTICE AND DISCLAIMER

TI PROVIDES TECHNICAL AND RELIABILITY DATA (INCLUDING DATA SHEETS), DESIGN RESOURCES (INCLUDING REFERENCE DESIGNS), APPLICATION OR OTHER DESIGN ADVICE, WEB TOOLS, SAFETY INFORMATION, AND OTHER RESOURCES "AS IS" AND WITH ALL FAULTS, AND DISCLAIMS ALL WARRANTIES, EXPRESS AND IMPLIED, INCLUDING WITHOUT LIMITATION ANY IMPLIED WARRANTIES OF MERCHANTABILITY, FITNESS FOR A PARTICULAR PURPOSE OR NON-INFRINGEMENT OF THIRD PARTY INTELLECTUAL PROPERTY RIGHTS.

These resources are intended for skilled developers designing with TI products. You are solely responsible for (1) selecting the appropriate TI products for your application, (2) designing, validating and testing your application, and (3) ensuring your application meets applicable standards, and any other safety, security, regulatory or other requirements.

These resources are subject to change without notice. TI grants you permission to use these resources only for development of an application that uses the TI products described in the resource. Other reproduction and display of these resources is prohibited. No license is granted to any other TI intellectual property right or to any third party intellectual property right. TI disclaims responsibility for, and you will fully indemnify TI and its representatives against, any claims, damages, costs, losses, and liabilities arising out of your use of these resources.

TI's products are provided subject to [TI's Terms of Sale](#) or other applicable terms available either on ti.com or provided in conjunction with such TI products. TI's provision of these resources does not expand or otherwise alter TI's applicable warranties or warranty disclaimers for TI products.

TI objects to and rejects any additional or different terms you may have proposed.

Mailing Address: Texas Instruments, Post Office Box 655303, Dallas, Texas 75265
Copyright © 2022, Texas Instruments Incorporated