

## CDx4HC4002 High-Speed CMOS Logic Dual 4-Input NOR Gate

### 1 Features

- Typical propagation delay = 8 ns at  $V_{CC} = 5\text{ V}$ ,  $C_L = 15\text{ pF}$ ,  $T_A = 25^\circ\text{C}$
- Fanout (over temperature range)
  - Standard outputs: 10 LSTTL loads
  - Bus driver outputs: 15 LSTTL loads
- Wide operating temperature range:  $-55^\circ\text{C}$  to  $125^\circ\text{C}$
- Balanced propagation delay and transition times
- Significant power reduction compared to LSTTL Logic ICs
- HC Types
  - 2 V to 6 V operation
  - High noise immunity:  $N_{IL} = 30\%$ ,  $N_{IH} = 30\%$  of  $V_{CC}$  at  $V_{CC} = 5\text{ V}$

### 2 Description

The 'HC4002 logic gate utilizes silicon gate CMOS technology to achieve operating speeds similar to LSTTL gates with the low power consumption of standard CMOS integrated circuits. All devices have the ability to drive 10 LSTTL loads. The 'HC4002 logic family is functional as well as pin compatible with the standard LS logic family.

#### Device Information

PART NUMBER	PACKAGE <sup>(1)</sup>	BODY SIZE (NOM)
CD74HC4002M	SOIC (14)	8.65 mm × 3.9 mm
CD54HC4002F3A	CDIP (14)	19.55 mm × 6.71 mm
CD74HC4002E	PDIP (14)	19.31 mm × 6.35 mm
CD74HC4002PW	TSSOP (14)	5.0 mm × 4.4 mm

(1) For all available packages, see the orderable addendum at the end of the data sheet.

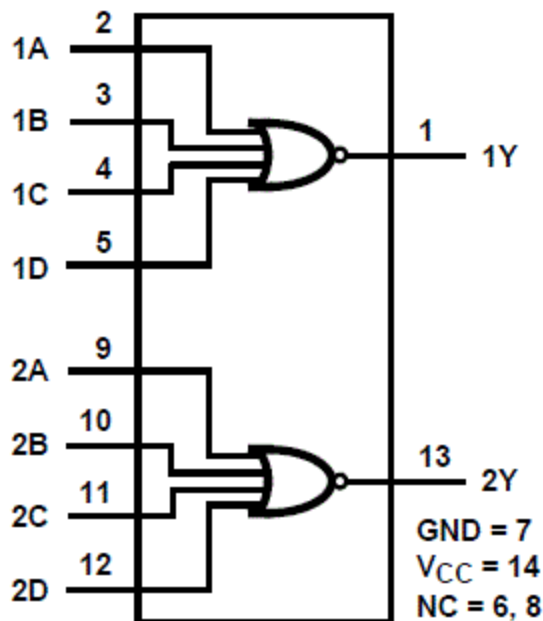

Functional Block Diagram



## Table of Contents

<b>1 Features</b> .....	1	7.2 Functional Block Diagram.....	7
<b>2 Description</b> .....	1	7.3 Device Functional Modes.....	7
<b>3 Revision History</b> .....	2	<b>8 Power Supply Recommendations</b> .....	8
<b>4 Pin Configuration and Functions</b> .....	3	<b>9 Layout</b> .....	8
<b>5 Specifications</b> .....	4	9.1 Layout Guidelines.....	8
5.1 Absolute Maximum Ratings.....	4	<b>10 Device and Documentation Support</b> .....	9
5.2 Recommended Operating Conditions.....	4	10.1 Receiving Notification of Documentation Updates....	9
5.3 Thermal Information.....	4	10.2 Support Resources.....	9
5.4 Electrical Characteristics.....	5	10.3 Trademarks.....	9
5.5 Switching Characteristics.....	5	10.4 Electrostatic Discharge Caution.....	9
<b>6 Parameter Measurement Information</b> .....	6	10.5 Glossary.....	9
<b>7 Detailed Description</b> .....	7	<b>11 Mechanical, Packaging, and Orderable Information</b> .....	9
7.1 Overview.....	7		

### 3 Revision History

NOTE: Page numbers for previous revisions may differ from page numbers in the current version.

<b>Changes from Revision E (October 2003) to Revision F (February 2022)</b>	<b>Page</b>
• Updated the numbering, formatting, tables, figures, and cross-references throughout the document to reflect modern data sheet standards.....	1

## 4 Pin Configuration and Functions

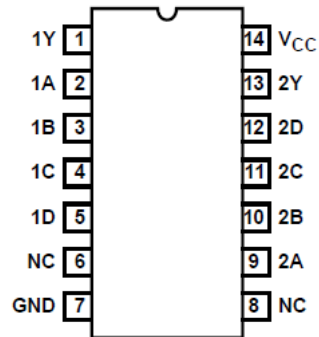

J, N, D, or PW package  
14-Pin CDIP, PDIP, SOIC, or TSSOP  
Top View

## 5 Specifications

### 5.1 Absolute Maximum Ratings

over operating free-air temperature range (unless otherwise noted)<sup>(1)</sup>

		MIN	MAX	UNIT
V <sub>CC</sub>	Supply voltage	-0.5	7	V
I <sub>IK</sub>	Input diode current	For V <sub>I</sub> < -0.5 V or V <sub>I</sub> > V <sub>CC</sub> + 0.5 V		± 20 mA
I <sub>OK</sub>	Output diode current	For V <sub>O</sub> < -0.5 V or V <sub>O</sub> > V <sub>CC</sub> + 0.5 V		± 20 mA
I <sub>O</sub>	Output source or sink current per output pin	For V <sub>O</sub> > -0.5 V or V <sub>O</sub> < V <sub>CC</sub> + 0.5 V		± 25 mA
	Continuous current V <sub>CC</sub> or ground current		± 50	mA
T <sub>J</sub>	Junction temperature		150	
T <sub>stg</sub>	Storage temperature range	- 65	150	
	Lead temperature (Soldering 10s) (SOIC - lead tips only)		300	

- (1) Stresses beyond those listed under *absolute maximum ratings* may cause permanent damage to the device. These are stress ratings only and functional operation of the device at these or any other conditions beyond those indicated under *recommended operating conditions* is not implied. Exposure to absolute-maximum-rated conditions for extended periods may affect device reliability.

### 5.2 Recommended Operating Conditions

		MIN	MAX	UNIT	
V <sub>CC</sub>	Supply voltage range	HC Types	2	6	V
		HCT Types	4.5	5.5	V
V <sub>I</sub> , V <sub>O</sub>	Input or output voltage	0	V <sub>CC</sub>	V	
t <sub>t</sub>	Input rise and fall time	2 V	1000	ns	
		4.5 V	500	ns	
		6 V	400	ns	
T <sub>A</sub>	Temperature range	-55	125	°C	

### 5.3 Thermal Information

THERMAL METRIC		D (SOIC)	N (PDIP)	NS (SO)	PW (TSSOP)	UNIT
		14 PINS	14 PINS	14 PINS	14 PINS	
R <sub>θJA</sub>	Junction-to-ambient thermal resistance <sup>(1)</sup>	86	80	76	113	°C/W

- (1) For more information about traditional and new thermal metrics, see the [Semiconductor and IC package thermal metrics](#) application report.

## 5.4 Electrical Characteristics

PARAMETER	TEST CONDITIONS <sup>(1)</sup>	V <sub>CC</sub> (V)	25 °C			-40°C to 85°C		-55°C to 125°C		UNIT
			MIN	TYP	MAX	MIN	MAX	MIN	MAX	
V <sub>IH</sub>	High level input voltage	2	1.5			1.5		1.5		V
		4.5	3.15			3.15		3.15		V
		6	4.2			4.2		4.2		V
V <sub>IL</sub>	Low level input voltage	2			0.5		0.5		0.5	V
		4.5			1.35		1.35		1.35	V
		6			1.8		1.8		1.8	V
V <sub>OH</sub>	High level output voltage	I <sub>OH</sub> = -20 µA	2	1.9		1.9		1.9		V
		I <sub>OH</sub> = -20 µA	4.5	4.4		4.4		4.4		V
		I <sub>OH</sub> = -20 µA	6	5.9		5.9		5.9		V
	High level output voltage	I <sub>OH</sub> = -4 mA	4.5	3.98		3.84		3.7		V
		I <sub>OH</sub> = -5.2 mA	6	5.48		5.34		5.2		V
V <sub>OL</sub>	Low level output voltage	I <sub>OL</sub> = 20 µA	2		0.1		0.1		0.1	V
		I <sub>OL</sub> = 20 µA	4.5		0.1		0.1		0.1	V
		I <sub>OL</sub> = 20 µA	6		0.1		0.1		0.1	V
	Low level output voltage	I <sub>OL</sub> = 4 mA	4.5		0.26		0.33		0.4	V
		I <sub>OL</sub> = 5.2 mA	6		0.26		0.33		0.4	V
I <sub>I</sub>	Input leakage current	V <sub>I</sub> = V <sub>CC</sub> or GND	6		±0.1		±1		±1	µA
I <sub>CC</sub>	Supply current	V <sub>I</sub> = V <sub>CC</sub> or GND	6		2		20		40	µA

(1) V<sub>I</sub> = V<sub>IH</sub> or V<sub>IL</sub>, unless otherwise noted.

## 5.5 Switching Characteristics

Input t<sub>r</sub>, t<sub>f</sub> = 6 ns

PARAMETER	TEST CONDITIONS	V <sub>CC</sub> (V)	25°C		-40°C to 85°C	-55°C to 125°C	UNIT	
			TYP	MAX	MAX	MAX		
<b>HC TYPES</b>								
t <sub>PLH</sub> , t <sub>PHL</sub>	Propagation delay, nA, nB, nC, nD to nY	C <sub>L</sub> = 50 pF	2		100	125	150	ns
			4.5		20	25	30	ns
			6		17	21	26	ns
		C <sub>L</sub> = 15 pF	5	8				ns
t <sub>TLH</sub> , t <sub>THL</sub>	Output transition times (see Figure 1)	C <sub>L</sub> = 50 pF	2		75	95	110	ns
			4.5		15	19	22	ns
			6		13	16	19	ns
C <sub>IN</sub>	Input capacitance			10	10	10	pF	
C <sub>PD</sub>	Power dissipation capacitance <sup>(1) (2)</sup>	C <sub>L</sub> = 15 pF	5	22			pF	

(1) C<sub>PD</sub> is used to determine the dynamic power consumption, per gate.

(2) P<sub>D</sub> = V<sub>CC</sub><sup>2</sup> f<sub>i</sub> (C<sub>PD</sub> + C<sub>L</sub>) where f<sub>i</sub> = input frequency, C<sub>L</sub> = output load capacitance, V<sub>CC</sub> = supply voltage.

## 6 Parameter Measurement Information

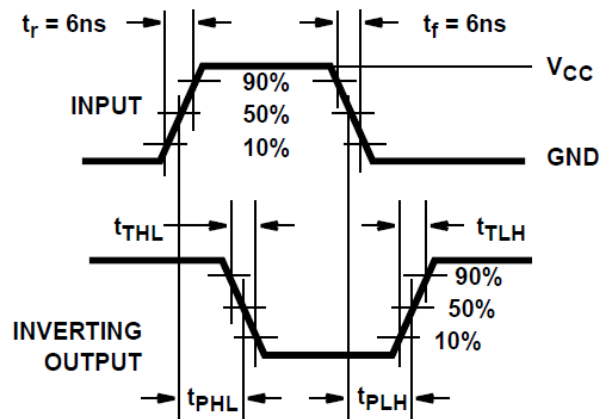

Figure 6-1. HC and HCU Transition Times and Propagation Delay Times, Combination Logic

## 7 Detailed Description

### 7.1 Overview

The 'HC4002 logic gate utilizes silicon gate CMOS technology to achieve operating speeds similar to LSTTL gates with the low power consumption of standard CMOS integrated circuits. All devices have the ability to drive 10 LSTTL loads. The 'HC4002 logic family is functional as well as pin compatible with the standard LS logic family.

### 7.2 Functional Block Diagram

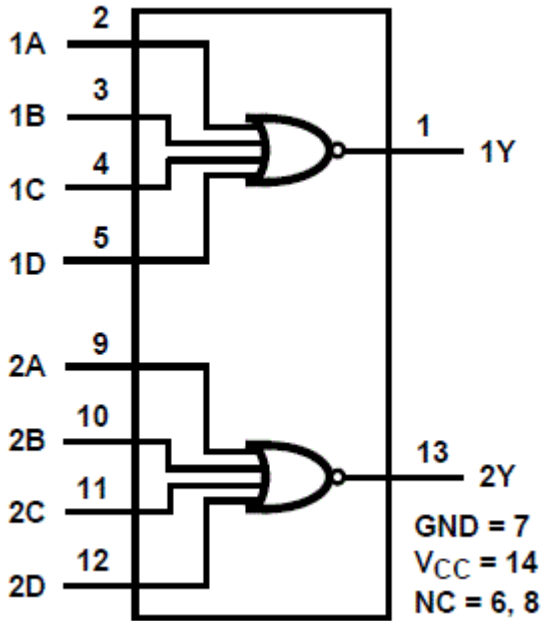

Figure 7-1. Functional Diagram

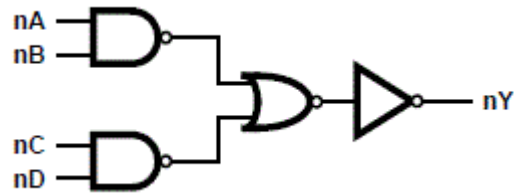

Figure 7-2. Logic Symbol

### 7.3 Device Functional Modes

Table 7-1. Truth Table<sup>(1)</sup>

INPUTS				OUTPUT
nA	nB	nC	nD	nY
L	L	L	L	H
H	X	X	X	L
X	H	X	X	L
X	X	H	X	L
X	X	X	H	L

(1) H = High Voltage Level, L = Low Voltage Level, X = Irrelevant

## 8 Power Supply Recommendations

The power supply can be any voltage between the minimum and maximum supply voltage rating located in the *Recommended Operating Conditions*. Each  $V_{CC}$  terminal should have a good bypass capacitor to prevent power disturbance. A 0.1- $\mu\text{F}$  capacitor is recommended for this device. It is acceptable to parallel multiple bypass caps to reject different frequencies of noise. The 0.1- $\mu\text{F}$  and 1- $\mu\text{F}$  capacitors are commonly used in parallel. The bypass capacitor should be installed as close to the power terminal as possible for best results.

## 9 Layout

### 9.1 Layout Guidelines

When using multiple-input and multiple-channel logic devices inputs must not ever be left floating. In many cases, functions or parts of functions of digital logic devices are unused; for example, when only two inputs of a triple-input AND gate are used or only 3 of the 4 buffer gates are used. Such unused input pins must not be left unconnected because the undefined voltages at the outside connections result in undefined operational states. All unused inputs of digital logic devices must be connected to a logic high or logic low voltage, as defined by the input voltage specifications, to prevent them from floating. The logic level that must be applied to any particular unused input depends on the function of the device. Generally, the inputs are tied to GND or  $V_{CC}$ , whichever makes more sense for the logic function or is more convenient.

## 10 Device and Documentation Support

TI offers an extensive line of development tools. Tools and software to evaluate the performance of the device, generate code, and develop solutions are listed below.

### 10.1 Receiving Notification of Documentation Updates

To receive notification of documentation updates, navigate to the device product folder on [ti.com](http://ti.com). Click on *Subscribe to updates* to register and receive a weekly digest of any product information that has changed. For change details, review the revision history included in any revised document.

### 10.2 Support Resources

[TI E2E™ support forums](#) are an engineer's go-to source for fast, verified answers and design help — straight from the experts. Search existing answers or ask your own question to get the quick design help you need.

Linked content is provided "AS IS" by the respective contributors. They do not constitute TI specifications and do not necessarily reflect TI's views; see TI's [Terms of Use](#).

### 10.3 Trademarks

TI E2E™ is a trademark of Texas Instruments.  
All trademarks are the property of their respective owners.

### 10.4 Electrostatic Discharge Caution



This integrated circuit can be damaged by ESD. Texas Instruments recommends that all integrated circuits be handled with appropriate precautions. Failure to observe proper handling and installation procedures can cause damage.

ESD damage can range from subtle performance degradation to complete device failure. Precision integrated circuits may be more susceptible to damage because very small parametric changes could cause the device not to meet its published specifications.

### 10.5 Glossary

[TI Glossary](#) This glossary lists and explains terms, acronyms, and definitions.

## 11 Mechanical, Packaging, and Orderable Information

The following pages include mechanical, packaging, and orderable information. This information is the most current data available for the designated devices. This data is subject to change without notice and revision of this document. For browser-based versions of this data sheet, refer to the left-hand navigation.

## PACKAGING INFORMATION

Orderable Device	Status (1)	Package Type	Package Drawing	Pins	Package Qty	Eco Plan (2)	Lead finish/ Ball material (6)	MSL Peak Temp (3)	Op Temp (°C)	Device Marking (4/5)	Samples
CD54HC4002F3A	ACTIVE	CDIP	J	14	1	Non-RoHS & Green	SNPB	N / A for Pkg Type	-55 to 125	8404401CA CD54HC4002F3A	<a href="#">Samples</a>
CD74HC4002E	ACTIVE	PDIP	N	14	25	RoHS & Green	NIPDAU	N / A for Pkg Type	-55 to 125	CD74HC4002E	<a href="#">Samples</a>
CD74HC4002M	ACTIVE	SOIC	D	14	50	RoHS & Green	NIPDAU	Level-1-260C-UNLIM	-55 to 125	HC4002M	<a href="#">Samples</a>
CD74HC4002M96	ACTIVE	SOIC	D	14	2500	RoHS & Green	NIPDAU	Level-1-260C-UNLIM	-55 to 125	HC4002M	<a href="#">Samples</a>
CD74HC4002MT	ACTIVE	SOIC	D	14	250	RoHS & Green	NIPDAU	Level-1-260C-UNLIM	-55 to 125	HC4002M	<a href="#">Samples</a>
CD74HC4002PW	ACTIVE	TSSOP	PW	14	90	RoHS & Green	NIPDAU	Level-1-260C-UNLIM	-55 to 125	HJ4002	<a href="#">Samples</a>
CD74HC4002PWR	ACTIVE	TSSOP	PW	14	2000	RoHS & Green	NIPDAU	Level-1-260C-UNLIM	-55 to 125	HJ4002	<a href="#">Samples</a>

(1) The marketing status values are defined as follows:

**ACTIVE:** Product device recommended for new designs.

**LIFEBUY:** TI has announced that the device will be discontinued, and a lifetime-buy period is in effect.

**NRND:** Not recommended for new designs. Device is in production to support existing customers, but TI does not recommend using this part in a new design.

**PREVIEW:** Device has been announced but is not in production. Samples may or may not be available.

**OBSELETE:** TI has discontinued the production of the device.

(2) **RoHS:** TI defines "RoHS" to mean semiconductor products that are compliant with the current EU RoHS requirements for all 10 RoHS substances, including the requirement that RoHS substance do not exceed 0.1% by weight in homogeneous materials. Where designed to be soldered at high temperatures, "RoHS" products are suitable for use in specified lead-free processes. TI may reference these types of products as "Pb-Free".

**RoHS Exempt:** TI defines "RoHS Exempt" to mean products that contain lead but are compliant with EU RoHS pursuant to a specific EU RoHS exemption.

**Green:** TI defines "Green" to mean the content of Chlorine (Cl) and Bromine (Br) based flame retardants meet JS709B low halogen requirements of <=1000ppm threshold. Antimony trioxide based flame retardants must also meet the <=1000ppm threshold requirement.

(3) MSL, Peak Temp. - The Moisture Sensitivity Level rating according to the JEDEC industry standard classifications, and peak solder temperature.

(4) There may be additional marking, which relates to the logo, the lot trace code information, or the environmental category on the device.

(5) Multiple Device Markings will be inside parentheses. Only one Device Marking contained in parentheses and separated by a "-" will appear on a device. If a line is indented then it is a continuation of the previous line and the two combined represent the entire Device Marking for that device.

(6) Lead finish/Ball material - Orderable Devices may have multiple material finish options. Finish options are separated by a vertical ruled line. Lead finish/Ball material values may wrap to two lines if the finish value exceeds the maximum column width.

**Important Information and Disclaimer:**The information provided on this page represents TI's knowledge and belief as of the date that it is provided. TI bases its knowledge and belief on information provided by third parties, and makes no representation or warranty as to the accuracy of such information. Efforts are underway to better integrate information from third parties. TI has taken and continues to take reasonable steps to provide representative and accurate information but may not have conducted destructive testing or chemical analysis on incoming materials and chemicals. TI and TI suppliers consider certain information to be proprietary, and thus CAS numbers and other limited information may not be available for release.

In no event shall TI's liability arising out of such information exceed the total purchase price of the TI part(s) at issue in this document sold by TI to Customer on an annual basis.

**OTHER QUALIFIED VERSIONS OF CD54HC4002, CD74HC4002 :**

- Catalog : [CD74HC4002](#)
- Military : [CD54HC4002](#)

NOTE: Qualified Version Definitions:

- Catalog - TI's standard catalog product
- Military - QML certified for Military and Defense Applications

**TAPE AND REEL INFORMATION**

**QUADRANT ASSIGNMENTS FOR PIN 1 ORIENTATION IN TAPE**

\*All dimensions are nominal

Device	Package Type	Package Drawing	Pins	SPQ	Reel Diameter (mm)	Reel Width W1 (mm)	A0 (mm)	B0 (mm)	K0 (mm)	P1 (mm)	W (mm)	Pin1 Quadrant
CD74HC4002M96	SOIC	D	14	2500	330.0	16.4	6.5	9.0	2.1	8.0	16.0	Q1
CD74HC4002MT	SOIC	D	14	250	330.0	16.4	6.5	9.0	2.1	8.0	16.0	Q1
CD74HC4002PWR	TSSOP	PW	14	2000	330.0	12.4	6.9	5.6	1.6	8.0	12.0	Q1
CD74HC4002PWR	TSSOP	PW	14	2000	330.0	12.4	6.9	5.6	1.6	8.0	12.0	Q1

**TAPE AND REEL BOX DIMENSIONS**

\*All dimensions are nominal

Device	Package Type	Package Drawing	Pins	SPQ	Length (mm)	Width (mm)	Height (mm)
CD74HC4002M96	SOIC	D	14	2500	853.0	449.0	35.0
CD74HC4002MT	SOIC	D	14	250	210.0	185.0	35.0
CD74HC4002PWR	TSSOP	PW	14	2000	853.0	449.0	35.0
CD74HC4002PWR	TSSOP	PW	14	2000	853.0	449.0	35.0

**TUBE**

\*All dimensions are nominal

Device	Package Name	Package Type	Pins	SPQ	L (mm)	W (mm)	T (μm)	B (mm)
CD74HC4002E	N	PDIP	14	25	506	13.97	11230	4.32
CD74HC4002E	N	PDIP	14	25	506	13.97	11230	4.32
CD74HC4002M	D	SOIC	14	50	506.6	8	3940	4.32
CD74HC4002PW	PW	TSSOP	14	90	530	10.2	3600	3.5

J 14

**GENERIC PACKAGE VIEW**  
**CDIP - 5.08 mm max height**  
CERAMIC DUAL IN LINE PACKAGE



Images above are just a representation of the package family, actual package may vary.  
Refer to the product data sheet for package details.

4040083-5/G



# J0014A

# PACKAGE OUTLINE

## CDIP - 5.08 mm max height

CERAMIC DUAL IN LINE PACKAGE



4214771/A 05/2017

### NOTES:

1. All controlling linear dimensions are in inches. Dimensions in brackets are in millimeters. Any dimension in brackets or parenthesis are for reference only. Dimensioning and tolerancing per ASME Y14.5M.
2. This drawing is subject to change without notice.
3. This package is hermetically sealed with a ceramic lid using glass frit.
4. Index point is provided on cap for terminal identification only and on press ceramic glass frit seal only.
5. Falls within MIL-STD-1835 and GDIP1-T14.

# EXAMPLE BOARD LAYOUT

J0014A

CDIP - 5.08 mm max height

CERAMIC DUAL IN LINE PACKAGE



LAND PATTERN EXAMPLE  
NON-SOLDER MASK DEFINED  
SCALE: 5X



4214771/A 05/2017

D (R-PDSO-G14)

PLASTIC SMALL OUTLINE

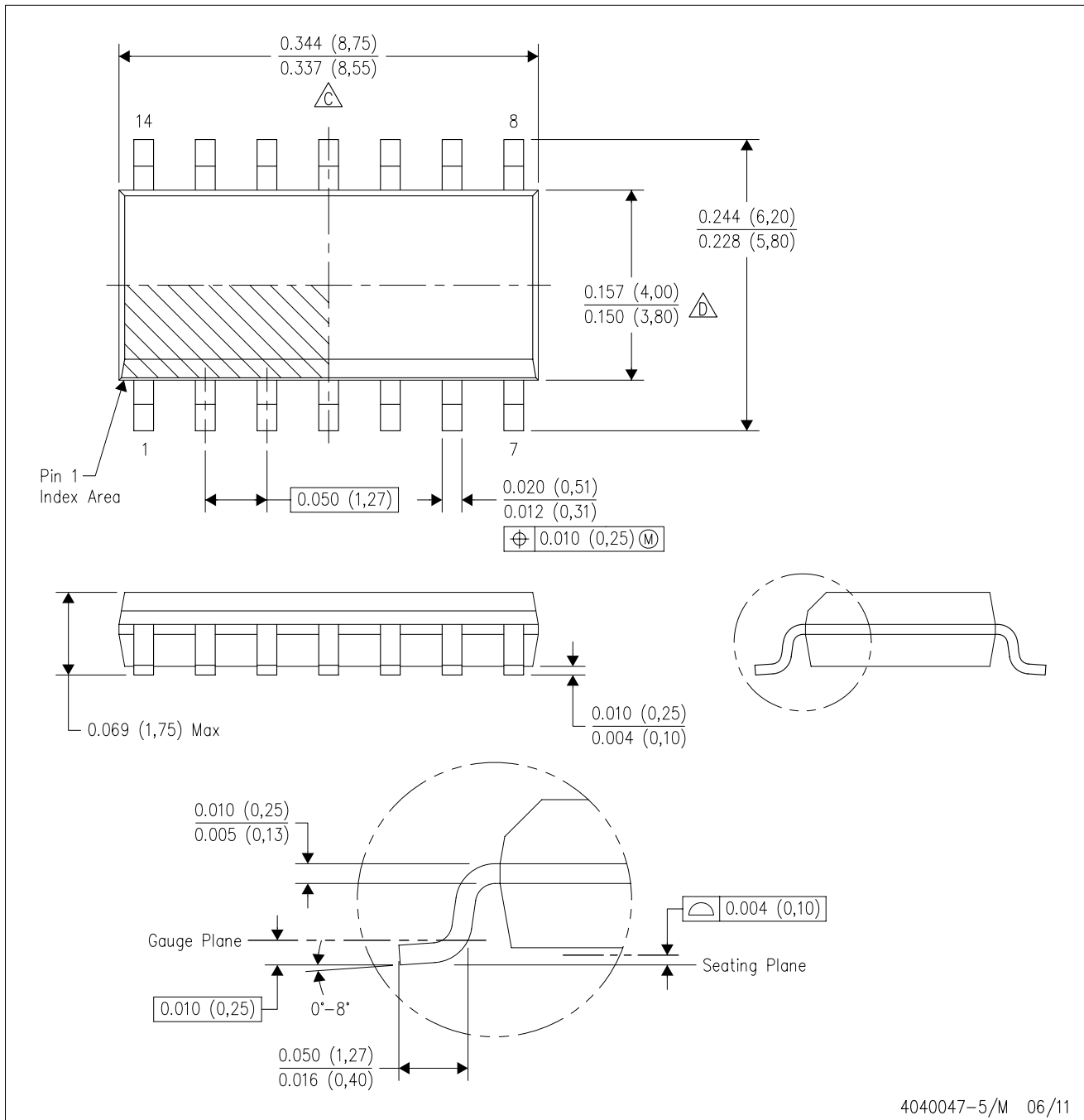

- NOTES:
- A. All linear dimensions are in inches (millimeters).
  - B. This drawing is subject to change without notice.
  - Body length does not include mold flash, protrusions, or gate burrs. Mold flash, protrusions, or gate burrs shall not exceed 0.006 (0,15) each side.
  - Body width does not include interlead flash. Interlead flash shall not exceed 0.017 (0,43) each side.
  - E. Reference JEDEC MS-012 variation AB.

D (R-PDSO-G14)

PLASTIC SMALL OUTLINE



- NOTES:
- A. All linear dimensions are in millimeters.
  - B. This drawing is subject to change without notice.
  - C. Publication IPC-7351 is recommended for alternate designs.
  - D. Laser cutting apertures with trapezoidal walls and also rounding corners will offer better paste release. Customers should contact their board assembly site for stencil design recommendations. Refer to IPC-7525 for other stencil recommendations.
  - E. Customers should contact their board fabrication site for solder mask tolerances between and around signal pads.

PW (R-PDSO-G14)

PLASTIC SMALL OUTLINE

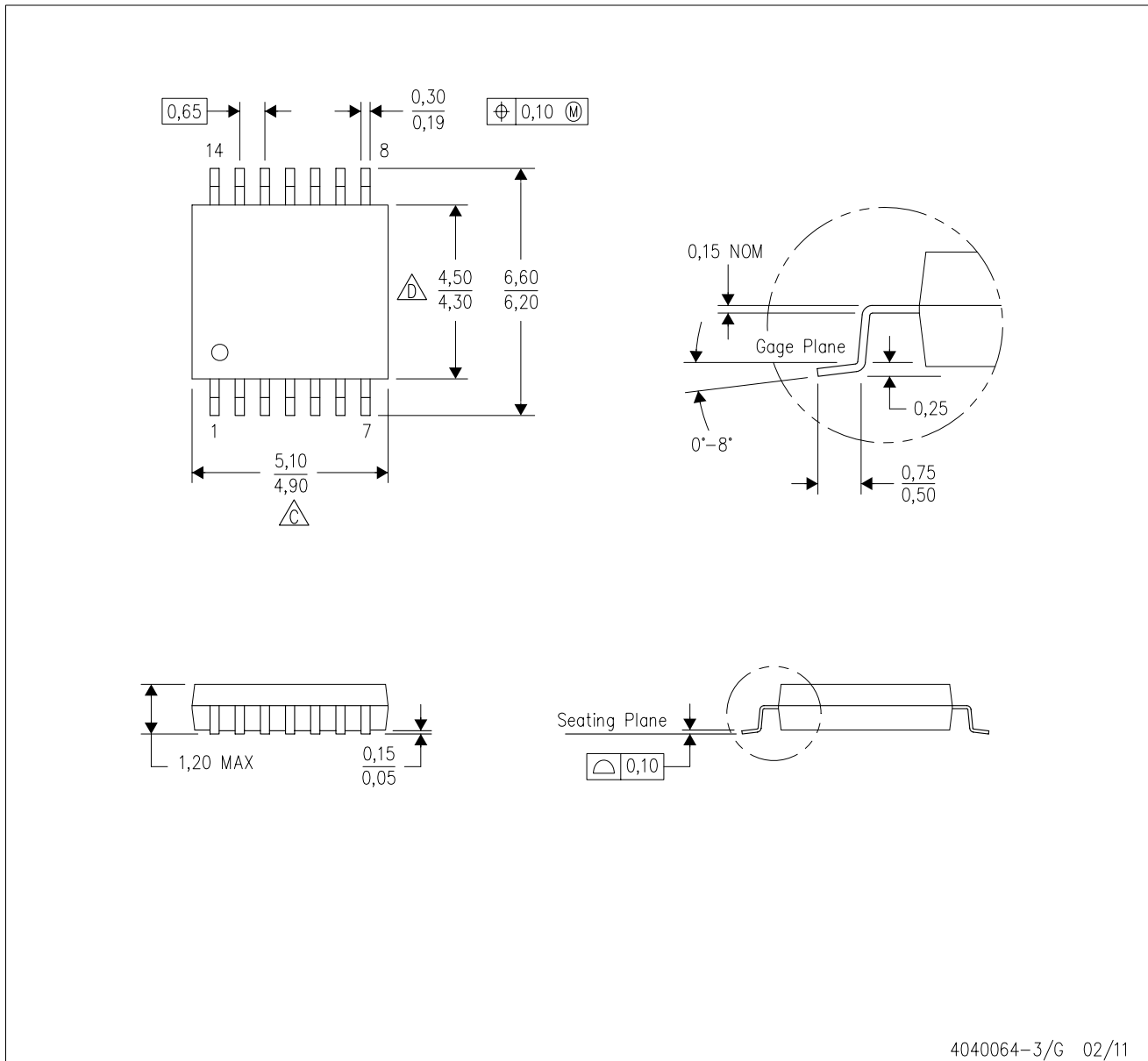

4040064-3/G 02/11

- NOTES:
- A. All linear dimensions are in millimeters. Dimensioning and tolerancing per ASME Y14.5M-1994.
  - B. This drawing is subject to change without notice.
  - C. Body length does not include mold flash, protrusions, or gate burrs. Mold flash, protrusions, or gate burrs shall not exceed 0,15 each side.
  - D. Body width does not include interlead flash. Interlead flash shall not exceed 0,25 each side.
  - E. Falls within JEDEC MO-153

PW (R-PDSO-G14)

PLASTIC SMALL OUTLINE



- NOTES:
- All linear dimensions are in millimeters.
  - This drawing is subject to change without notice.
  - Publication IPC-7351 is recommended for alternate designs.
  - Laser cutting apertures with trapezoidal walls and also rounding corners will offer better paste release. Customers should contact their board assembly site for stencil design recommendations. Refer to IPC-7525 for other stencil recommendations.
  - Customers should contact their board fabrication site for solder mask tolerances between and around signal pads.

N (R-PDIP-T\*\*)

PLASTIC DUAL-IN-LINE PACKAGE

16 PINS SHOWN



- NOTES:
- A. All linear dimensions are in inches (millimeters).
  - B. This drawing is subject to change without notice.
  - C Falls within JEDEC MS-001, except 18 and 20 pin minimum body length (Dim A).
  - D The 20 pin end lead shoulder width is a vendor option, either half or full width.

4040049/E 12/2002

## IMPORTANT NOTICE AND DISCLAIMER

TI PROVIDES TECHNICAL AND RELIABILITY DATA (INCLUDING DATA SHEETS), DESIGN RESOURCES (INCLUDING REFERENCE DESIGNS), APPLICATION OR OTHER DESIGN ADVICE, WEB TOOLS, SAFETY INFORMATION, AND OTHER RESOURCES "AS IS" AND WITH ALL FAULTS, AND DISCLAIMS ALL WARRANTIES, EXPRESS AND IMPLIED, INCLUDING WITHOUT LIMITATION ANY IMPLIED WARRANTIES OF MERCHANTABILITY, FITNESS FOR A PARTICULAR PURPOSE OR NON-INFRINGEMENT OF THIRD PARTY INTELLECTUAL PROPERTY RIGHTS.

These resources are intended for skilled developers designing with TI products. You are solely responsible for (1) selecting the appropriate TI products for your application, (2) designing, validating and testing your application, and (3) ensuring your application meets applicable standards, and any other safety, security, regulatory or other requirements.

These resources are subject to change without notice. TI grants you permission to use these resources only for development of an application that uses the TI products described in the resource. Other reproduction and display of these resources is prohibited. No license is granted to any other TI intellectual property right or to any third party intellectual property right. TI disclaims responsibility for, and you will fully indemnify TI and its representatives against, any claims, damages, costs, losses, and liabilities arising out of your use of these resources.

TI's products are provided subject to [TI's Terms of Sale](#) or other applicable terms available either on [ti.com](http://ti.com) or provided in conjunction with such TI products. TI's provision of these resources does not expand or otherwise alter TI's applicable warranties or warranty disclaimers for TI products.

TI objects to and rejects any additional or different terms you may have proposed.

Mailing Address: Texas Instruments, Post Office Box 655303, Dallas, Texas 75265  
Copyright © 2022, Texas Instruments Incorporated