

具有快速进位的高速 CMOS 逻辑 4 位二进制全加器

1 特性

- 添加两个二进制数
- 全面的内部前瞻
- 用于经济型扩展的快速纹波进位
- 在正负逻辑下运行
- 扇出 (在温度范围内)
 - 标准输出 10 个 LSTTL 负载
 - 总线驱动器输出 15 个 LSTTL 负载
- 宽工作温度范围: -55°C 至 125°C
- 平衡的传播延迟及转换时间
- 与 LSTTL 逻辑 IC 相比, 功耗显著降低
- HC 类型
 - 工作电压为 2V 至 6V
 - 高抗噪性: 当 $V_{CC} = 5V$ 时, $N_{IL} = 30%$, $N_{IH} = V_{CC}$ 的 30%
- HCT 类型
 - 工作电压为 4.5V 至 5.5V
 - 直接 LSTTL 输入逻辑兼容性, $V_{IL} = 0.8V$ (最大值), $V_{IH} = 2V$ (最小值)
 - CMOS 输入兼容性, 在 V_{OL} 、 V_{OH} 下 $I_I \leq 1\mu A$

2 说明

CDx4HC283 和 CDx4HCT283 包含 4 位二进制加法器。HCT 器件具有 TTL 电压兼容输入。

器件信息

器件型号	封装 ⁽¹⁾	封装尺寸 (标称值)
CD54HC283	J (CDIP、16)	24.38mm × 6.92mm
CD74HC283CD74HC283	D (SOIC、16)	9.90mm × 3.90mm
	N (PDIP、16)	19.31mm × 6.35mm
CD74HCT283CD74HCT283	D (SOIC、16)	9.90mm × 3.90mm
	N (PDIP、16)	19.31mm × 6.35mm

(1) 如需了解所有封装, 请参阅数据表末尾的可订购产品附录。

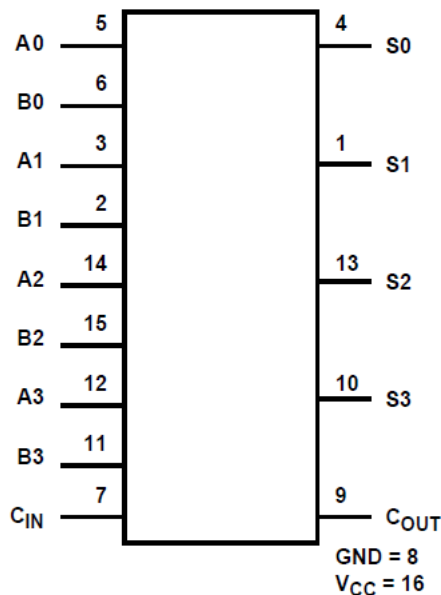

Table of Contents

1 特性	1	7.2 Functional Block Diagram.....	9
2 说明	1	7.3 Feature Description.....	9
3 Revision History	2	8 Power Supply Recommendations	10
4 Pin Configuration and Functions	3	9 Layout	10
5 Specifications	4	9.1 Layout Guidelines.....	10
5.1 Absolute Maximum Ratings ⁽¹⁾	4	10 Device and Documentation Support	11
5.2 Recommended Operating Conditions.....	4	10.1 接收文档更新通知.....	11
5.3 Thermal Information.....	4	10.2 支持资源.....	11
5.4 Electrical Characteristics.....	5	10.3 Trademarks.....	11
5.5 Switching Characteristics.....	6	10.4 Electrostatic Discharge Caution.....	11
6 Parameter Measurement Information	8	10.5 术语表.....	11
7 Detailed Description	9	11 Mechanical, Packaging, and Orderable Information	11
7.1 Overview.....	9		

3 Revision History

注：以前版本的页码可能与当前版本的页码不同

Changes from Revision D (October 2003) to Revision E (July 2022)	Page
• 更新了整个文档中的编号、格式、表格、图和交叉参考，以反映现代数据表标准.....	1

4 Pin Configuration and Functions

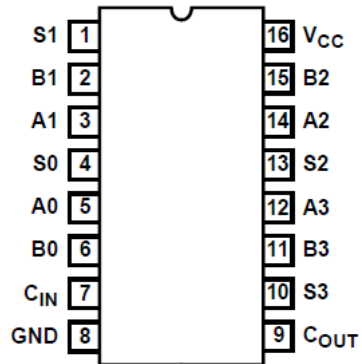

J, N, or D package
16-Pin CDIP, PDIP, or SOIC
Top View

5 Specifications

5.1 Absolute Maximum Ratings⁽¹⁾

			MIN	MAX	UNIT
V _{CC}	Supply voltage		- 0.5	7	V
I _{IK}	Input diode current	For V _I < - 0.5 V or V _I > V _{CC} + 0.5 V		±20	mA
I _{OK}	Output diode current	For V _O < - 0.5 V or V _O > V _{CC} + 0.5 V		±20	mA
I _O	Drain current, per output	For - 0.5 V < V _O < V _{CC} + 0.5 V		±25	mA
I _O	Output source or sink current per output pin	For V _O > - 0.5 V or V _O < V _{CC} + 0.5 V		±25	mA
	Continuous current through V _{CC} or GND			±50	mA
T _J	Junction temperature			150	°C
T _{stg}	Storage temperature range		- 65	150	°C
	Lead temperature (Soldering 10s)(SOIC - lead tips only)			300	°C

- (1) Stresses above those listed in “Absolute Maximum Ratings” may cause permanent damage to the device. This is a stress only rating and operation of the device at these or any other conditions above those indicated in the operational sections of this specification is not implied.

5.2 Recommended Operating Conditions

			MIN	MAX	UNIT
V _{CC}	Supply voltage range	HC types	2	6	V
V _I , V _O	DC input or output voltage		0	V _{CC}	V
	Input rise and fall time	2 V		1000	ns
		4.5 V		500	
		6 V		400	
T _A	Temperature range		- 55	125	V

5.3 Thermal Information

THERMAL METRIC		D (SOIC)	N (PDIP)	UNIT
		16 PINS	16 PINS	
R _{θJA}	Junction-to-ambient thermal resistance ⁽¹⁾	73	67	°C/W

- (1) For more information about traditional and new thermal metrics, see the [Semiconductor and IC Package Thermal Metrics](#) application report.

5.4 Electrical Characteristics

PARAMETER		TEST CONDITIONS ⁽²⁾	V _{CC} (V)	25°C			- 40°C to 85°C		- 55°C to 125°C		UNIT
				MIN	TYP	MAX	MIN	MAX	MIN	MAX	
HC TYPES											
V _{IH}	High level input voltage		2	1.5		1.5		1.5		V	
			4.5	3.15		3.15		3.15			
			6	4.2		4.2		4.2			
V _{IL}	Low level input voltage		2			0.5		0.5		V	
			4.5			1.35		1.35			
			6			1.8		1.8			
V _{OH}	High level output voltage	I _{OH} = - 20 μA	2	1.9		1.9		1.9		V	
		I _{OH} = - 20 μA	4.5	4.4		4.4		4.4			
		I _{OH} = - 20 μA	6	5.9		5.9		5.9			
		I _{OH} = - 4 mA	4.5	3.98		3.84		3.7		V	
		I _{OH} = - 5.2 mA	6	6		5.34		5.2			
V _{OL}	Low level output voltage	I _{OL} = 20 μA	2			0.1		0.1		V	
		I _{OL} = 20 μA	4.5			0.1		0.1			
		I _{OL} = 20 μA	6			0.1		0.1			
		I _{OL} = 4 mA	4.5			0.26		0.33		V	
		I _{OL} = 5.2 mA	6			0.26		0.33			
I _I	Input leakage current	V _{CC} or GND	6			±0.1		±1		μA	
I _{CC}	Supply current	V _{CC} or GND	6			8		80		160	μA
HCT Types											
V _{IH}	High level input voltage		4.5 to 5.5	2		2		2		V	
V _{IL}	Low level input voltage		4.5 to 5.5			0.8		0.8		V	
V _{OH}	High level output voltage	I _{OH} = - 20 μA	4.5	4.4		4.4		4.4		V	
V _{OH}		I _{OH} = - 4 mA	4.5	3.98		3.84		3.7		V	
V _{OL}	Low level output voltage	I _{OL} = 20 μA	4.5			0.1		0.1		V	
V _{OL}		I _{OL} = 4 mA	4.5			0.26		0.33		V	
I _I	Input leakage current	V _{CC} to GND	5.5			±0.1		±1		μA	
I _{CC}	Supply current	V _{CC} or GND	5.5			8		80		160	μA
Δ I _{CC} ⁽¹⁾	Additional supply current per input pin	C _{IN} input held at V _{CC} - 2.1	4.5 to 5.5	100		540		675		735	μA
		B1, A1, A0 inputs held at V _{CC} - 2.1	4.5 to 5.5	100		360		450		490	μA
		B0 input held at V _{CC} - 2.1	4.5 to 5.5	100		144		180		196	μA
		B3, A3, A2, B2 inputs held at V _{CC} - 2.1	4.5 to 5.5	100		180		225		245	μA

(1) For dual-supply systems theoretical worst case (V_I = 2.4 V, V_{CC} = 5.5 V) specification is 1.8 mA.

(2) V_I = V_{IH} or V_{IL}, unless otherwise noted.

5.5 Switching Characteristics

PARAMETER		TEST CONDITIONS	V _{CC} (V)	25°C			- 40 to 85°C		- 55°C to 125°C		UNIT
				MIN	TYP	MAX	MIN	MAX	MIN	MAX	
HC TYPES											
t _{PLH} , t _{PHL}	Propagation delay C _{IN} to S0	C _L = 50 pF	2		160		200		240	ns	
			4.5		32		40		45		
		C _L = 15 pF	5		13						
		C _L = 50 pF	6		27		34		41		
t _{PLH} , t _{PHL}	C _{IN} to S1	C _L = 50 pF	2		180		225		270	ns	
			4.5		36		45		54		
		C _L = 15 pF	5		15						
t _{PLH} , t _{PHL}	C _{IN} to S2, C _{IN} to C _{OUT}	C _L = 50 pF	2		195		245		295	ns	
			4.5		39		49		59		
		C _L = 15 pF	5		16						
t _{PLH} , t _{PHL}	C _{IN} to S3	C _L = 50 pF	2		230		290		345	ns	
			4.5		46		58		69		
		C _L = 15 pF	5		19						
t _{PLH} , t _{PHL}	An, Bn to C _{OUT}	C _L = 50 pF	2		195		245		295	ns	
			4.5		39		49		59		
		C _L = 15 pF	5		16						
t _{PLH} , t _{PHL}	An, Bn to Sn	C _L = 50 pF	2		210		265		315	ns	
			4.5		42		53		63		
		C _L = 15 pF	5		18						
t _{PLH} , t _{PHL}	An, Bn to Sn	C _L = 50 pF	2		210		265		315	ns	
			4.5		42		53		63		
		C _L = 15 pF	5		18						
t _{TLH} , t _{THL}	Output transition time	C _L = 50 pF	2		75		95		110	ns	
			4.5		15		19		22		
			6		13		16		19		
C _{IN}	Input capacitance	C _L = 50 pF	-		10		10		10	pF	
C _{PD}	Power dissipation capacitance ^{(1) (2)}		5		70					pF	
HCT TYPES											
t _{PLH} , t _{PHL}	Propagation delay C _{IN} to S0	C _L = 15 pF	5		13					ns	
		C _L = 50 pF	4.5		31		39		47		
t _{PLH} , t _{PHL}	C _{IN} to S1	C _L = 15 pF	5		18					ns	
		C _L = 50 pF	4.5		43		54		65		
t _{PLH} , t _{PHL}	C _{IN} to S2, C _{IN} to C _{OUT}	C _L = 15 pF	5		19					ns	
		C _L = 50 pF	4.5		46		58		69		
t _{PLH} , t _{PHL}	C _{IN} to S3	C _L = 15 pF	5		22					ns	
		C _L = 50 pF	4.5		53		66		80		
t _{PLH} , t _{PHL}	An, Bn to C _{OUT}	C _L = 15 pF	5		20					ns	
		C _L = 50 pF	4.5		48		60		72		
t _{PLH} , t _{PHL}	An, Bn to Sn	C _L = 15 pF	5		21					ns	
		C _L = 50 pF	4.5		49		61		74		

5.5 Switching Characteristics (continued)

PARAMETER		TEST CONDITIONS	V _{CC} (V)	25°C			- 40 to 85°C		- 55°C to 125°C		UNIT
				MIN	TYP	MAX	MIN	MAX	MIN	MAX	
t _{TLH} , t _{THL}	Output transition time	C _L = 50 pF	4.5			15		19		22	ns
C _{IN}	Input capacitance					10		10		10	pF
C _{PD}	Power dissipation capacitance ^{(1) (2)}		5		82						pF

- (1) C_{PD} is used to determine the dynamic power consumption, per package.
 (2) $P_D = V_{CC}^2 f_i (C_{PD} + C_L)$ where: f_i = Input Frequency, C_L = Output Load Capacitance, V_{CC} = Supply Voltage.

6 Parameter Measurement Information

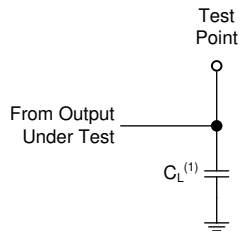

1. Includes probe and test-fixture capacitance.

图 6-1. Load Circuit for Push-Pull Output



图 6-2. HC and HCT Transition Times and Propagation Delay Times, Combination Logic



图 6-3. HCT Transition Times and Propagation Delay Times, Combination Logic

1. The greater between t_r and t_f is the same as t_t .
2. The greater between t_{plh} and t_{phi} is the same as t_{pd} .

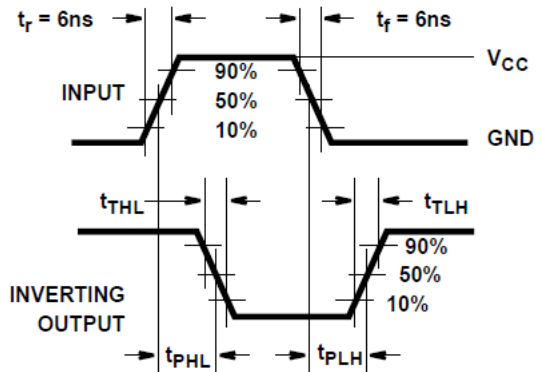
7 Detailed Description

7.1 Overview

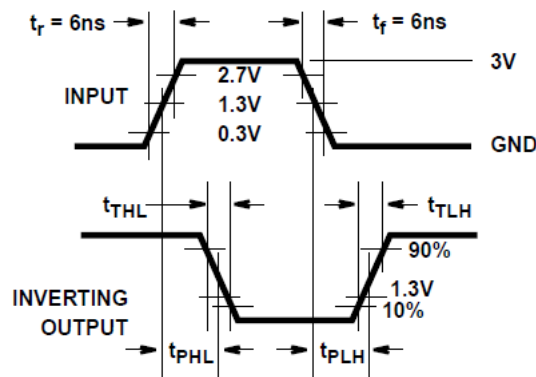
The ' HC283 and ' HCT283 binary full adders add two 4-bit binary numbers and generate a carry-out bit if the sum exceeds 15.

Because of the symmetry of the add function, this device can be used with either all active-high operands (positive logic) or with all active-low operands (negative logic). When using positive logic the carry-in input must be tied low if there is no carry-in.

7.2 Functional Block Diagram

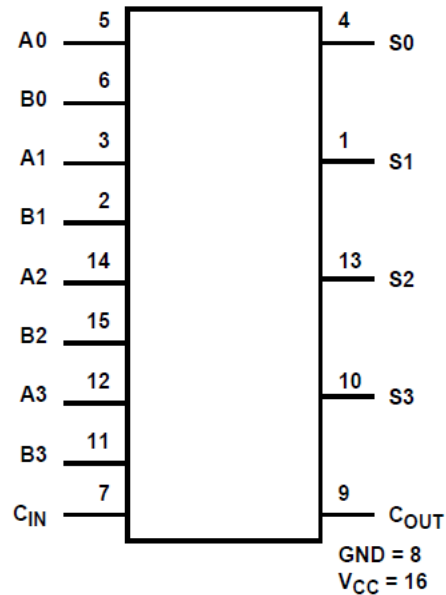

7.3 Feature Description

- Balanced CMOS Push-Pull Outputs
- Clamp Diode Structure

8 Power Supply Recommendations

The power supply can be any voltage between the minimum and maximum supply voltage rating located in the *Recommended Operating Conditions*. Each V_{CC} terminal should have a good bypass capacitor to prevent power disturbance. A 0.1- μ F capacitor is recommended for this device. It is acceptable to parallel multiple bypass caps to reject different frequencies of noise. The 0.1- μ F and 1- μ F capacitors are commonly used in parallel. The bypass capacitor should be installed as close to the power terminal as possible for best results.

9 Layout

9.1 Layout Guidelines

When using multiple-input and multiple-channel logic devices inputs must not ever be left floating. In many cases, functions or parts of functions of digital logic devices are unused; for example, when only two inputs of a triple-input AND gate are used or only 3 of the 4 buffer gates are used. Such unused input pins must not be left unconnected because the undefined voltages at the outside connections result in undefined operational states. All unused inputs of digital logic devices must be connected to a logic high or logic low voltage, as defined by the input voltage specifications, to prevent them from floating. The logic level that must be applied to any particular unused input depends on the function of the device. Generally, the inputs are tied to GND or V_{CC} , whichever makes more sense for the logic function or is more convenient.

10 Device and Documentation Support

TI offers an extensive line of development tools. Tools and software to evaluate the performance of the device, generate code, and develop solutions are listed below.

10.1 接收文档更新通知

要接收文档更新通知，请导航至 ti.com 上的器件产品文件夹。点击 [订阅更新](#) 进行注册，即可每周接收产品信息更改摘要。有关更改的详细信息，请查看任何已修订文档中包含的修订历史记录。

10.2 支持资源

[TI E2E™ 支持论坛](#) 是工程师的重要参考资料，可直接从专家获得快速、经过验证的解答和设计帮助。搜索现有解答或提出自己的问题可获得所需的快速设计帮助。

链接的内容由各个贡献者“按原样”提供。这些内容并不构成 TI 技术规范，并且不一定反映 TI 的观点；请参阅 TI 的 [《使用条款》](#)。

10.3 Trademarks

TI E2E™ is a trademark of Texas Instruments.

所有商标均为其各自所有者的财产。

10.4 Electrostatic Discharge Caution



This integrated circuit can be damaged by ESD. Texas Instruments recommends that all integrated circuits be handled with appropriate precautions. Failure to observe proper handling and installation procedures can cause damage.

ESD damage can range from subtle performance degradation to complete device failure. Precision integrated circuits may be more susceptible to damage because very small parametric changes could cause the device not to meet its published specifications.

10.5 术语表

[TI 术语表](#) 本术语表列出并解释了术语、首字母缩略词和定义。

11 Mechanical, Packaging, and Orderable Information

The following pages include mechanical, packaging, and orderable information. This information is the most current data available for the designated devices. This data is subject to change without notice and revision of this document. For browser-based versions of this data sheet, refer to the left-hand navigation.

PACKAGING INFORMATION

Orderable Device	Status (1)	Package Type	Package Drawing	Pins	Package Qty	Eco Plan (2)	Lead finish/ Ball material (6)	MSL Peak Temp (3)	Op Temp (°C)	Device Marking (4/5)	Samples
5962-8976501EA	ACTIVE	CDIP	J	16	1	Non-RoHS & Green	SNPB	N / A for Pkg Type	-55 to 125	5962-8976501EA CD54HC283F3A	Samples
CD54HC283F3A	ACTIVE	CDIP	J	16	1	Non-RoHS & Green	SNPB	N / A for Pkg Type	-55 to 125	5962-8976501EA CD54HC283F3A	Samples
CD54HCT283F3A	ACTIVE	CDIP	J	16	1	Non-RoHS & Green	SNPB	N / A for Pkg Type	-55 to 125	CD54HCT283F3A	Samples
CD74HC283E	ACTIVE	PDIP	N	16	25	RoHS & Green	NIPDAU	N / A for Pkg Type	-55 to 125	CD74HC283E	Samples
CD74HC283M	ACTIVE	SOIC	D	16	40	RoHS & Green	NIPDAU	Level-1-260C-UNLIM	-55 to 125	HC283M	Samples
CD74HC283M96	ACTIVE	SOIC	D	16	2500	RoHS & Green	NIPDAU	Level-1-260C-UNLIM	-55 to 125	HC283M	Samples
CD74HC283ME4	ACTIVE	SOIC	D	16	40	RoHS & Green	NIPDAU	Level-1-260C-UNLIM	-55 to 125	HC283M	Samples
CD74HC283MT	ACTIVE	SOIC	D	16	250	RoHS & Green	NIPDAU	Level-1-260C-UNLIM	-55 to 125	HC283M	Samples
CD74HCT283E	ACTIVE	PDIP	N	16	25	RoHS & Green	NIPDAU	N / A for Pkg Type	-55 to 125	CD74HCT283E	Samples
CD74HCT283M	ACTIVE	SOIC	D	16	40	RoHS & Green	NIPDAU	Level-1-260C-UNLIM	-55 to 125	HCT283M	Samples
CD74HCT283M96	ACTIVE	SOIC	D	16	2500	RoHS & Green	NIPDAU	Level-1-260C-UNLIM	-55 to 125	HCT283M	Samples
CD74HCT283M96G4	ACTIVE	SOIC	D	16	2500	TBD	Call TI	Call TI	-55 to 125		Samples
CD74HCT283MG4	ACTIVE	SOIC	D	16	40	TBD	Call TI	Call TI	-55 to 125		Samples
CD74HCT283MT	ACTIVE	SOIC	D	16	250	RoHS & Green	NIPDAU	Level-1-260C-UNLIM	-55 to 125	HCT283M	Samples

(1) The marketing status values are defined as follows:

ACTIVE: Product device recommended for new designs.

LIFEBUY: TI has announced that the device will be discontinued, and a lifetime-buy period is in effect.

NRND: Not recommended for new designs. Device is in production to support existing customers, but TI does not recommend using this part in a new design.

PREVIEW: Device has been announced but is not in production. Samples may or may not be available.

OBSOLETE: TI has discontinued the production of the device.

(2) **RoHS:** TI defines "RoHS" to mean semiconductor products that are compliant with the current EU RoHS requirements for all 10 RoHS substances, including the requirement that RoHS substance do not exceed 0.1% by weight in homogeneous materials. Where designed to be soldered at high temperatures, "RoHS" products are suitable for use in specified lead-free processes. TI may reference these types of products as "Pb-Free".

RoHS Exempt: TI defines "RoHS Exempt" to mean products that contain lead but are compliant with EU RoHS pursuant to a specific EU RoHS exemption.

Green: TI defines "Green" to mean the content of Chlorine (Cl) and Bromine (Br) based flame retardants meet JS709B low halogen requirements of ≤ 1000 ppm threshold. Antimony trioxide based flame retardants must also meet the ≤ 1000 ppm threshold requirement.

(3) MSL, Peak Temp. - The Moisture Sensitivity Level rating according to the JEDEC industry standard classifications, and peak solder temperature.

(4) There may be additional marking, which relates to the logo, the lot trace code information, or the environmental category on the device.

(5) Multiple Device Markings will be inside parentheses. Only one Device Marking contained in parentheses and separated by a "~" will appear on a device. If a line is indented then it is a continuation of the previous line and the two combined represent the entire Device Marking for that device.

(6) Lead finish/Ball material - Orderable Devices may have multiple material finish options. Finish options are separated by a vertical ruled line. Lead finish/Ball material values may wrap to two lines if the finish value exceeds the maximum column width.

Important Information and Disclaimer: The information provided on this page represents TI's knowledge and belief as of the date that it is provided. TI bases its knowledge and belief on information provided by third parties, and makes no representation or warranty as to the accuracy of such information. Efforts are underway to better integrate information from third parties. TI has taken and continues to take reasonable steps to provide representative and accurate information but may not have conducted destructive testing or chemical analysis on incoming materials and chemicals. TI and TI suppliers consider certain information to be proprietary, and thus CAS numbers and other limited information may not be available for release.

In no event shall TI's liability arising out of such information exceed the total purchase price of the TI part(s) at issue in this document sold by TI to Customer on an annual basis.

OTHER QUALIFIED VERSIONS OF CD54HC283, CD54HCT283, CD74HC283, CD74HCT283 :

● Catalog : [CD74HC283](#), [CD74HCT283](#)

● Military : [CD54HC283](#), [CD54HCT283](#)

NOTE: Qualified Version Definitions:

● Catalog - TI's standard catalog product

● Military - QML certified for Military and Defense Applications

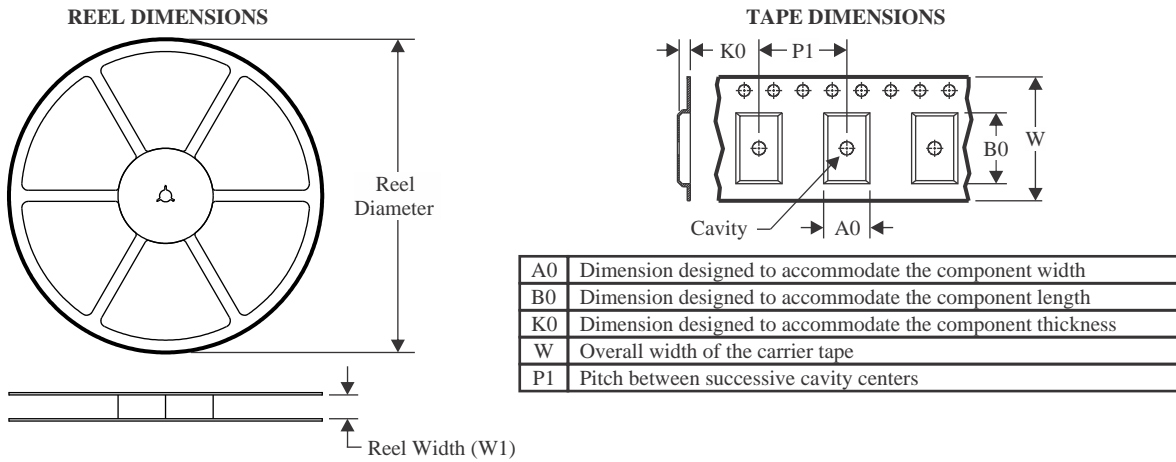
TAPE AND REEL INFORMATION

QUADRANT ASSIGNMENTS FOR PIN 1 ORIENTATION IN TAPE

*All dimensions are nominal

Device	Package Type	Package Drawing	Pins	SPQ	Reel Diameter (mm)	Reel Width W1 (mm)	A0 (mm)	B0 (mm)	K0 (mm)	P1 (mm)	W (mm)	Pin1 Quadrant
CD74HC283M96	SOIC	D	16	2500	330.0	16.4	6.5	10.3	2.1	8.0	16.0	Q1
CD74HCT283M96	SOIC	D	16	2500	330.0	16.4	6.5	10.3	2.1	8.0	16.0	Q1

TAPE AND REEL BOX DIMENSIONS

*All dimensions are nominal

Device	Package Type	Package Drawing	Pins	SPQ	Length (mm)	Width (mm)	Height (mm)
CD74HC283M96	SOIC	D	16	2500	340.5	336.1	32.0
CD74HCT283M96	SOIC	D	16	2500	340.5	336.1	32.0

TUBE

*All dimensions are nominal

Device	Package Name	Package Type	Pins	SPQ	L (mm)	W (mm)	T (μm)	B (mm)
CD74HC283E	N	PDIP	16	25	506	13.97	11230	4.32
CD74HC283E	N	PDIP	16	25	506	13.97	11230	4.32
CD74HC283M	D	SOIC	16	40	507	8	3940	4.32
CD74HC283ME4	D	SOIC	16	40	507	8	3940	4.32
CD74HCT283E	N	PDIP	16	25	506	13.97	11230	4.32
CD74HCT283E	N	PDIP	16	25	506	13.97	11230	4.32
CD74HCT283M	D	SOIC	16	40	507	8	3940	4.32

J (R-GDIP-T**)

14 LEADS SHOWN

CERAMIC DUAL IN-LINE PACKAGE



DIM \ PINS **	14	16	18	20
A	0.300 (7,62) BSC	0.300 (7,62) BSC	0.300 (7,62) BSC	0.300 (7,62) BSC
B MAX	0.785 (19,94)	.840 (21,34)	0.960 (24,38)	1.060 (26,92)
B MIN	—	—	—	—
C MAX	0.300 (7,62)	0.300 (7,62)	0.310 (7,87)	0.300 (7,62)
C MIN	0.245 (6,22)	0.245 (6,22)	0.220 (5,59)	0.245 (6,22)



4040083/F 03/03

- NOTES:
- All linear dimensions are in inches (millimeters).
 - This drawing is subject to change without notice.
 - This package is hermetically sealed with a ceramic lid using glass frit.
 - Index point is provided on cap for terminal identification only on press ceramic glass frit seal only.
 - Falls within MIL STD 1835 GDIP1-T14, GDIP1-T16, GDIP1-T18 and GDIP1-T20.

N (R-PDIP-T**)

PLASTIC DUAL-IN-LINE PACKAGE

16 PINS SHOWN



4040049/E 12/2002

- NOTES:
- A. All linear dimensions are in inches (millimeters).
 - B. This drawing is subject to change without notice.
 - △ Falls within JEDEC MS-001, except 18 and 20 pin minimum body length (Dim A).
 - ⊕ The 20 pin end lead shoulder width is a vendor option, either half or full width.

D (R-PDSO-G16)

PLASTIC SMALL OUTLINE



4040047-6/M 06/11

- NOTES:
- A. All linear dimensions are in inches (millimeters).
 - B. This drawing is subject to change without notice.
 -  C. Body length does not include mold flash, protrusions, or gate burrs. Mold flash, protrusions, or gate burrs shall not exceed 0.006 (0,15) each side.
 -  D. Body width does not include interlead flash. Interlead flash shall not exceed 0.017 (0,43) each side.
 - E. Reference JEDEC MS-012 variation AC.

D (R-PDSO-G16)

PLASTIC SMALL OUTLINE



- NOTES:
- All linear dimensions are in millimeters.
 - This drawing is subject to change without notice.
 - Publication IPC-7351 is recommended for alternate designs.
 - Laser cutting apertures with trapezoidal walls and also rounding corners will offer better paste release. Customers should contact their board assembly site for stencil design recommendations. Refer to IPC-7525 for other stencil recommendations.
 - Customers should contact their board fabrication site for solder mask tolerances between and around signal pads.

重要声明和免责声明

TI“按原样”提供技术和可靠性数据（包括数据表）、设计资源（包括参考设计）、应用或其他设计建议、网络工具、安全信息和其他资源，不保证没有瑕疵且不做任何明示或暗示的担保，包括但不限于对适销性、某特定用途方面的适用性或不侵犯任何第三方知识产权的暗示担保。

这些资源可供使用 TI 产品进行设计的熟练开发人员使用。您将自行承担以下全部责任：(1) 针对您的应用选择合适的 TI 产品，(2) 设计、验证并测试您的应用，(3) 确保您的应用满足相应标准以及任何其他功能安全、信息安全、监管或其他要求。

这些资源如有变更，恕不另行通知。TI 授权您仅可将这些资源用于研发本资源所述的 TI 产品的应用。严禁对这些资源进行其他复制或展示。您无权使用任何其他 TI 知识产权或任何第三方知识产权。您应全额赔偿因在这些资源的使用中对 TI 及其代表造成的任何索赔、损害、成本、损失和债务，TI 对此概不负责。

TI 提供的产品受 [TI 的销售条款](#) 或 [ti.com](#) 上其他适用条款/TI 产品随附的其他适用条款的约束。TI 提供这些资源并不会扩展或以其他方式更改 TI 针对 TI 产品发布的适用的担保或担保免责声明。

TI 反对并拒绝您可能提出的任何其他或不同的条款。

邮寄地址：Texas Instruments, Post Office Box 655303, Dallas, Texas 75265

Copyright © 2022，德州仪器 (TI) 公司