

CD74HCT4543 BCD-TO-7 SEGMENT LATCH/DECODER/DRIVER

SCHS281A – REVISED MAY 2003

- 4.5-V to 5.5-V V_{CC} Operation
- Input Latches for BCD Code Storage
- Blanking Capability
- Phase Input for Complementing Outputs
- Fanout (Over Temperature Range)
 - Standard Outputs – 10 LSTTL Loads
- Balanced Propagation Delay and Transition Times
- Significant Power Reduction, Compared to LSTTL Logic ICs
- Direct LSTTL Input Logic Compatibility, $V_{IL} = 0.8\text{ V}$ Maximum, $V_{IH} = 2\text{ V}$ Minimum
- CMOS Input Compatibility, $I_I \leq 1\ \mu\text{A}$ at V_{OL} , V_{OH}

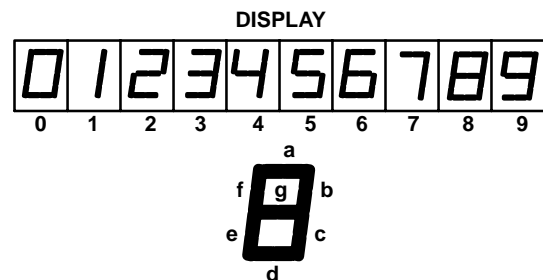
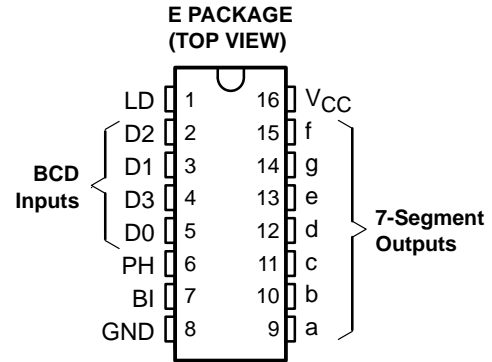

description/ordering information

The CD74HCT4543 high-speed silicon-gate is a BCD-to-7 segment latch/decoder/driver designed primarily for directly driving liquid-crystal displays. While the latch enable (LD) is low, the latches are enabled to store the BCD inputs. When the latch enable is high, the latches are disabled, making the outputs transparent to the BCD inputs. The device has an active-high blanking input (BI) and a phase input (PH) to which a square wave is applied for liquid-crystal applications. This square wave also is applied to the backplane of the liquid-crystal display.

ORDERING INFORMATION

T_A	PACKAGE†	ORDERABLE PART NUMBER	TOP-SIDE MARKING
-55°C to 125°C	PDIP – E Tube	CD74HCT4543E	CD74HCT4543E

† Package drawings, standard packing quantities, thermal data, symbolization, and PCB design guidelines are available at www.ti.com/sc/package.



Please be aware that an important notice concerning availability, standard warranty, and use in critical applications of Texas Instruments semiconductor products and disclaimers thereto appears at the end of this data sheet.

PRODUCTION DATA information is current as of publication date. Products conform to specifications per the terms of Texas Instruments standard warranty. Production processing does not necessarily include testing of all parameters.

 **TEXAS
INSTRUMENTS**

POST OFFICE BOX 655303 • DALLAS, TEXAS 75265

Copyright © 2003, Texas Instruments Incorporated

CD74HCT4543 BCD-TO-7 SEGMENT LATCH/DECODER/DRIVER

SCHS281A – REVISED MAY 2003

FUNCTION TABLE

LD	BI	PH	D ₃	D ₂	D ₁	D ₀	a	b	c	d	e	f	g	Display
X	H	L	X	X	X	X	L	L	L	L	L	L	L	Blank
H	L	L	L	L	L	L	H	H	H	H	H	H	L	0
H	L	L	L	L	L	H	L	H	L	L	L	L	L	1
H	L	L	L	L	H	L	H	H	L	H	H	L	H	2
H	L	L	L	L	H	H	H	H	H	L	L	L	H	3
H	L	L	L	H	L	L	L	H	H	L	L	H	H	4
H	L	L	L	H	L	H	H	L	H	H	L	H	H	5
H	L	L	L	H	H	L	H	L	H	H	H	H	H	6
H	L	L	L	H	H	H	H	H	L	L	L	L	L	7
H	L	L	H	L	L	L	H	H	H	H	H	H	H	8
H	L	L	H	L	L	H	H	H	L	H	L	H	H	9
H	L	L	H	L	H	L	L	L	L	L	L	L	L	Blank
H	L	L	H	L	H	H	L	L	L	L	L	L	L	Blank
H	L	L	H	H	L	L	L	L	L	L	L	L	L	Blank
H	L	L	H	H	L	H	L	L	L	L	L	L	L	Blank
H	L	L	H	H	H	L	L	L	L	L	L	L	L	Blank
H	L	L	H	H	H	H	L	L	L	L	L	L	L	Blank
L	L	L	X	X	X	X	†							†
As above	H		As above				Inverse of above							As above

† Depends on BCD code previously applied when LD = high.

functional diagram

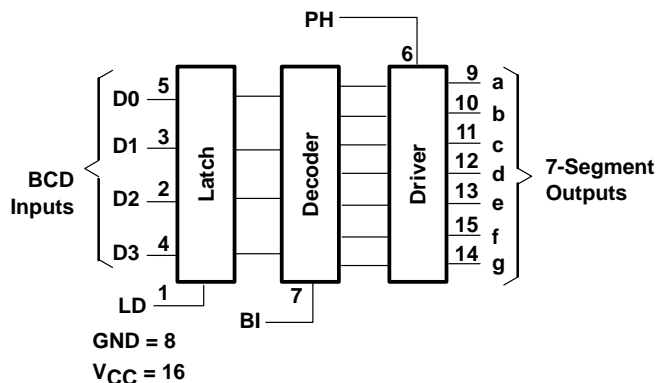

CD74HCT4543 BCD-TO-7 SEGMENT LATCH/DECODER/DRIVER

SCHS281A – REVISED MAY 2003

logic diagram

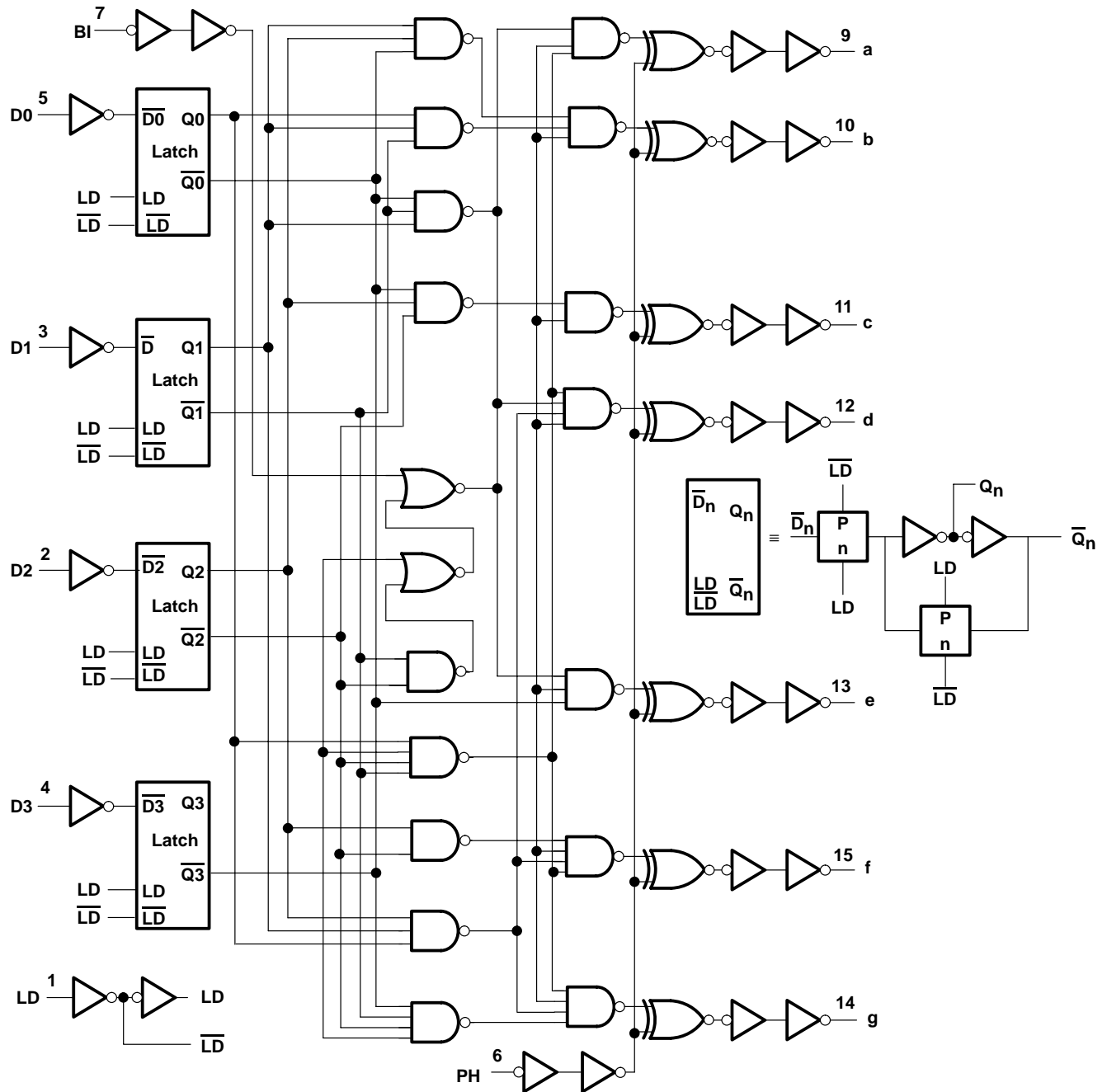

CD74HCT4543

BCD-TO-7 SEGMENT LATCH/DECODER/DRIVER

SCHS281A – REVISED MAY 2003

absolute maximum ratings over operating free-air temperature (unless otherwise noted)†

Supply voltage range, V_{CC}	-0.5 V to 7 V
Input diode current, I_{IK} ($V_I < -0.5$ V or $V_I > V_{CC} + 0.5$ V) (see Note 1)	± 20 mA
Output diode current, I_{OK} ($V_O < -0.5$ V or $V_O > V_{CC} + 0.5$ V) (see Note 1)	± 20 mA
Continuous output source or sink current per output, I_O ($V_O = 0$ to V_{CC})	± 25 mA
Continuous current through V_{CC} or GND	± 50 mA
Package thermal impedance, θ_{JA} (see Note 2)	67°C/W
At distance $1/16 \pm 1/32$ in. (1.59 ± 0.79 mm) from case for 10 s maximum	265°C
Unit inserted into a PC board (min. thickness $1/16$ in., 1.59 mm) with solder contacting lead tips only	300°C
Storage temperature, T_{stg}	-65 to 150°C

† Stresses beyond those listed under “absolute maximum ratings” may cause permanent damage to the device. These are stress ratings only, and functional operation of the device at these or any other conditions beyond those indicated under “recommended operating conditions” is not implied. Exposure to absolute-maximum-rated conditions for extended periods may affect device reliability.

- NOTES: 1. The input and output voltage ratings may be exceeded if the input and output current ratings are observed.
2. The package thermal impedance is calculated in accordance with JESD 51-7.

recommended operating conditions (see Note 3)

		$T_A = 25^\circ\text{C}$		$T_A = -55^\circ\text{C}$ TO 125°C		$T_A = -40^\circ\text{C}$ TO 85°C		UNIT
		MIN	MAX	MIN	MAX	MIN	MAX	
V_{CC}	Supply voltage	4.5	5.5	4.5	5.5	4.5	5.5	V
V_{IH}	High-level input voltage	2		2		2		V
V_{IL}	Low-level input voltage	0.8		0.8		0.8		V
V_I	Input voltage	V_{CC}		V_{CC}		V_{CC}		V
V_O	Output voltage	V_{CC}		V_{CC}		V_{CC}		V
t_t	Input transition (rise and fall) time	500		500		500		ns

NOTE 3: All unused inputs of the device must be held at V_{CC} or GND to ensure proper device operation. Refer to the TI application report, *Implications of Slow or Floating CMOS Inputs*, literature number SCBA004.

electrical characteristics over recommended operating free-air temperature range (unless otherwise noted)

PARAMETER	TEST CONDITIONS	V_{CC}	$T_A = 25^\circ\text{C}$			$T_A = -55^\circ\text{C}$ TO 125°C		$T_A = -40^\circ\text{C}$ TO 85°C		UNIT
			MIN	TYP	MAX	MIN	MAX	MIN	MAX	
V_{OH}	$V_I = V_{IH}$ or V_{IL}	4.5 V	$I_{OH} = -20 \mu\text{A}$		4.4		4.4		V	
			$I_{OH} = -4 \text{ mA}$		3.98		3.7			
V_{OL}	$V_I = V_{IH}$ or V_{IL}	4.5 V	$I_{OL} = 20 \mu\text{A}$		0.1		0.1		V	
			$I_{OL} = 4 \text{ mA}$		0.26		0.4			
I_I	$V_I = V_{CC}$ to GND	5.5 V	± 0.1			± 1		± 1		μA
I_{CC}	$V_I = V_{CC}$ or 0, $I_O = 0$	5.5 V	8			160		80		μA
ΔI_{CC}^\ddagger	One input at $V_{CC} - 2.1$ V, Other inputs at 0 or V_{CC}	4.5 V to 5.5 V	100 360			490		450		μA
C_i			10			10		10		pF

‡ Additional quiescent supply current per input pin, TTL inputs high, 1 unit load. For dual-supply systems, theoretical worst-case ($V_I = 2.4$ V, $V_{CC} = 5.5$ V) specification is 1.8 mA.



HCT INPUT LOADING TABLE

INPUT	UNIT LOADS†
D0, D1, D2	1
D3, BI	0.5
PH	1.25
LD	1.5

† Unit Load is ΔI_{CC} limit specified in electrical characteristics table, e.g., 360 μ A maximum at 25°C.

timing requirements over recommended operating free-air temperature range $V_{CC} = 4.5$ V (unless otherwise noted) (see Figure 1)

		$T_A = 25^\circ\text{C}$		$T_A = -55^\circ\text{C}$ TO 125°C		$T_A = -40^\circ\text{C}$ TO 85°C		UNIT
		MIN	MAX	MIN	MAX	MIN	MAX	
t_w	Pulse duration, LD high	10		15		13		ns
t_{su}	Setup time, BCD inputs before LD↓	12		18		15		ns
t_h	Hold time, BCD inputs before LD↓	8		12		10		ns

switching characteristics over recommended operating free-air temperature range (unless otherwise noted) (see Figure 2)

PARAMETER	FROM (INPUT)	TO (OUTPUT)	LOAD CAPACITANCE	V_{CC}	$T_A = 25^\circ\text{C}$			$T_A = -55^\circ\text{C}$ TO 125°C		$T_A = -40^\circ\text{C}$ TO 85°C		UNIT
					MIN	TYP	MAX	MIN	MAX	MIN	MAX	
t_{pd}	D_n	Output	$C_L = 50$ pF	4.5 V			80		120		100	ns
			$C_L = 15$ pF	5 V			33					
	LD	Output	$C_L = 50$ pF	4.5 V			77		116		96	
			$C_L = 15$ pF	5 V			32					
	BI	Output	$C_L = 50$ pF	4.5 V			66		99		83	
			$C_L = 15$ pF	5 V			27					
	PH	Output	$C_L = 50$ pF	4.5 V			66		99		83	
			$C_L = 15$ pF	5 V			27					
t_t		Any	$C_L = 50$ pF	4.5 V			50		75		63	ns

operating characteristics, $V_{CC} = 5$ V, $T_A = 25^\circ\text{C}$

PARAMETER	TYP	UNIT
C_{pd}^\ddagger Power dissipation capacitance	54	pF

‡ C_{pd} is used to determine the dynamic power consumption, per package.

$$P_D = C_{pd} V_{CC}^2 f_i + \sum C_L V_{CC}^2 f_o$$

where: f_i = input frequency

f_o = output frequency

C_L = output load capacitance

V_{CC} = supply voltage

CD74HCT4543 BCD-TO-7 SEGMENT LATCH/DECODER/DRIVER

SCHS281A – REVISED MAY 2003

PARAMETER MEASUREMENT INFORMATION

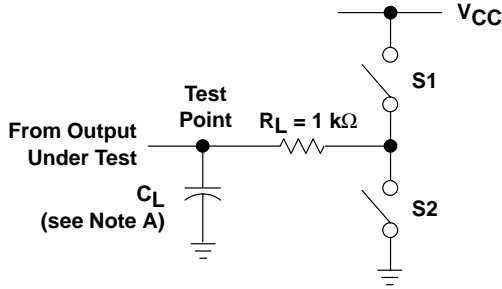

LOAD CIRCUIT

PARAMETER	S1	S2	
t_{en}	t_{PZH}	Open	Closed
	t_{PZL}	Closed	Open
t_{dis}	t_{PHZ}	Open	Closed
	t_{PLZ}	Closed	Open
t_{pd} or t_t	Open	Open	

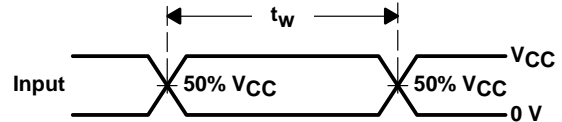

VOLTAGE WAVEFORMS
PULSE DURATION

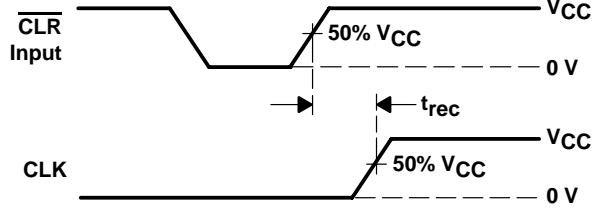

VOLTAGE WAVEFORMS
RECOVERY TIME

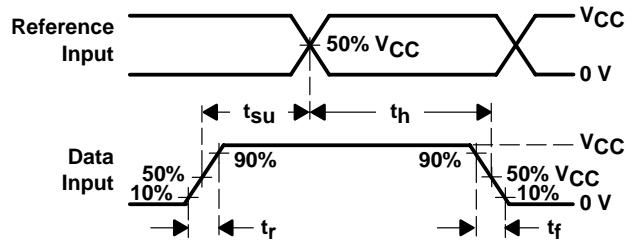

VOLTAGE WAVEFORMS
SETUP AND HOLD AND INPUT RISE AND FALL TIMES

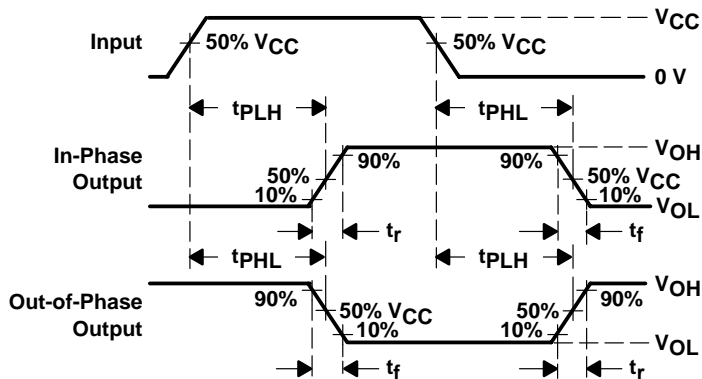

VOLTAGE WAVEFORMS
PROPAGATION DELAY AND OUTPUT TRANSITION TIMES

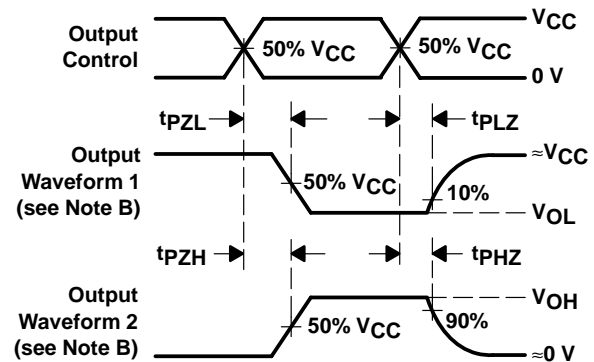

VOLTAGE WAVEFORMS
OUTPUT ENABLE AND DISABLE TIMES

- NOTES:
- C_L includes probe and test-fixture capacitance.
 - Waveform 1 is for an output with internal conditions such that the output is low except when disabled by the output control. Waveform 2 is for an output with internal conditions such that the output is high except when disabled by the output control.
 - Phase relationships between waveforms were chosen arbitrarily. All input pulses are supplied by generators having the following characteristics: $PRR \leq 1$ MHz, $Z_O = 50 \Omega$, $t_r = 6$ ns, $t_f = 6$ ns.
 - For clock inputs, f_{max} is measured with the input duty cycle at 50%.
 - The outputs are measured one at a time with one input transition per measurement.
 - t_{PLZ} and t_{PHZ} are the same as t_{dis} .
 - t_{PZL} and t_{PZH} are the same as t_{en} .
 - t_{PLH} and t_{PHL} are the same as t_{pd} .

Figure 1. Load Circuit and Voltage Waveforms



APPLICATION CIRCUITS

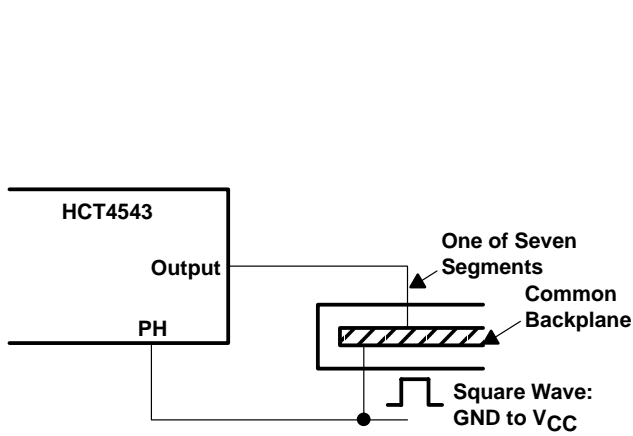

Figure 2. Connection to Liquid-Crystal Display (LCD)

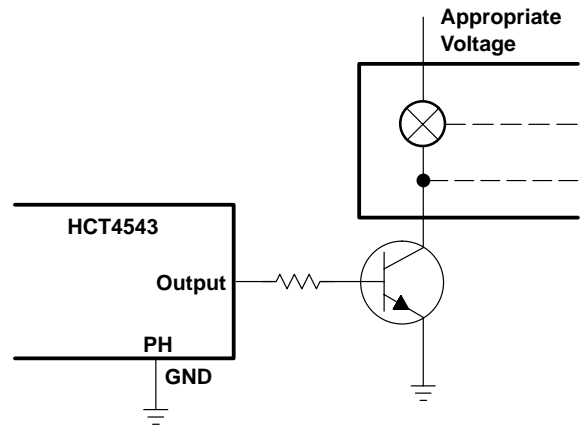

Figure 3. Connection to Incandescent Display

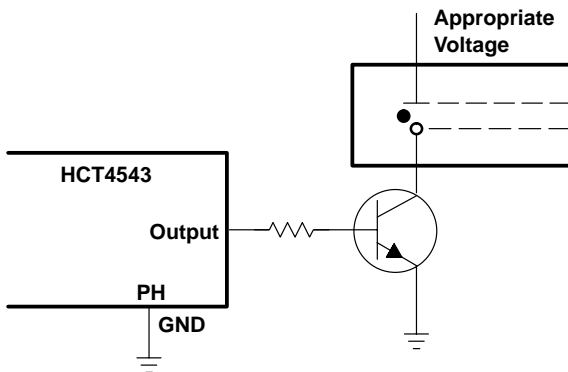

Figure 4. Connection to Gas-Discharge Display

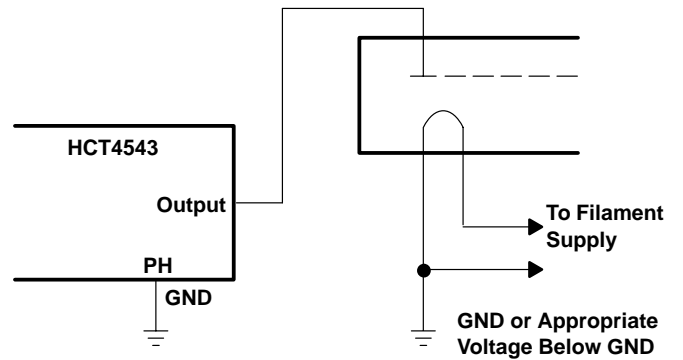

Figure 5. Connection to Fluorescent Display

PACKAGING INFORMATION

Orderable Device	Status (1)	Package Type	Package Drawing	Pins	Package Qty	Eco Plan (2)	Lead finish/ Ball material (6)	MSL Peak Temp (3)	Op Temp (°C)	Device Marking (4/5)	Samples
CD74HCT4543E	ACTIVE	PDIP	N	16	25	RoHS & Green	NIPDAU	N / A for Pkg Type	-55 to 125	CD74HCT4543E	Samples
CD74HCT4543EE4	ACTIVE	PDIP	N	16	25	RoHS & Green	NIPDAU	N / A for Pkg Type	-55 to 125	CD74HCT4543E	Samples

(1) The marketing status values are defined as follows:

ACTIVE: Product device recommended for new designs.

LIFEBUY: TI has announced that the device will be discontinued, and a lifetime-buy period is in effect.

NRND: Not recommended for new designs. Device is in production to support existing customers, but TI does not recommend using this part in a new design.

PREVIEW: Device has been announced but is not in production. Samples may or may not be available.

OBSOLETE: TI has discontinued the production of the device.

(2) **RoHS:** TI defines "RoHS" to mean semiconductor products that are compliant with the current EU RoHS requirements for all 10 RoHS substances, including the requirement that RoHS substance do not exceed 0.1% by weight in homogeneous materials. Where designed to be soldered at high temperatures, "RoHS" products are suitable for use in specified lead-free processes. TI may reference these types of products as "Pb-Free".

RoHS Exempt: TI defines "RoHS Exempt" to mean products that contain lead but are compliant with EU RoHS pursuant to a specific EU RoHS exemption.

Green: TI defines "Green" to mean the content of Chlorine (Cl) and Bromine (Br) based flame retardants meet JS709B low halogen requirements of <=1000ppm threshold. Antimony trioxide based flame retardants must also meet the <=1000ppm threshold requirement.

(3) MSL, Peak Temp. - The Moisture Sensitivity Level rating according to the JEDEC industry standard classifications, and peak solder temperature.

(4) There may be additional marking, which relates to the logo, the lot trace code information, or the environmental category on the device.

(5) Multiple Device Markings will be inside parentheses. Only one Device Marking contained in parentheses and separated by a "~" will appear on a device. If a line is indented then it is a continuation of the previous line and the two combined represent the entire Device Marking for that device.

(6) Lead finish/Ball material - Orderable Devices may have multiple material finish options. Finish options are separated by a vertical ruled line. Lead finish/Ball material values may wrap to two lines if the finish value exceeds the maximum column width.

Important Information and Disclaimer:The information provided on this page represents TI's knowledge and belief as of the date that it is provided. TI bases its knowledge and belief on information provided by third parties, and makes no representation or warranty as to the accuracy of such information. Efforts are underway to better integrate information from third parties. TI has taken and continues to take reasonable steps to provide representative and accurate information but may not have conducted destructive testing or chemical analysis on incoming materials and chemicals. TI and TI suppliers consider certain information to be proprietary, and thus CAS numbers and other limited information may not be available for release.

In no event shall TI's liability arising out of such information exceed the total purchase price of the TI part(s) at issue in this document sold by TI to Customer on an annual basis.

TUBE

*All dimensions are nominal

Device	Package Name	Package Type	Pins	SPQ	L (mm)	W (mm)	T (μm)	B (mm)
CD74HCT4543E	N	PDIP	16	25	506	13.97	11230	4.32
CD74HCT4543E	N	PDIP	16	25	506	13.97	11230	4.32
CD74HCT4543EE4	N	PDIP	16	25	506	13.97	11230	4.32
CD74HCT4543EE4	N	PDIP	16	25	506	13.97	11230	4.32

N (R-PDIP-T**)

PLASTIC DUAL-IN-LINE PACKAGE

16 PINS SHOWN



- NOTES:
- A. All linear dimensions are in inches (millimeters).
 - B. This drawing is subject to change without notice.
 - Falls within JEDEC MS-001, except 18 and 20 pin minimum body length (Dim A).
 - The 20 pin end lead shoulder width is a vendor option, either half or full width.

IMPORTANT NOTICE AND DISCLAIMER

TI PROVIDES TECHNICAL AND RELIABILITY DATA (INCLUDING DATA SHEETS), DESIGN RESOURCES (INCLUDING REFERENCE DESIGNS), APPLICATION OR OTHER DESIGN ADVICE, WEB TOOLS, SAFETY INFORMATION, AND OTHER RESOURCES "AS IS" AND WITH ALL FAULTS, AND DISCLAIMS ALL WARRANTIES, EXPRESS AND IMPLIED, INCLUDING WITHOUT LIMITATION ANY IMPLIED WARRANTIES OF MERCHANTABILITY, FITNESS FOR A PARTICULAR PURPOSE OR NON-INFRINGEMENT OF THIRD PARTY INTELLECTUAL PROPERTY RIGHTS.

These resources are intended for skilled developers designing with TI products. You are solely responsible for (1) selecting the appropriate TI products for your application, (2) designing, validating and testing your application, and (3) ensuring your application meets applicable standards, and any other safety, security, regulatory or other requirements.

These resources are subject to change without notice. TI grants you permission to use these resources only for development of an application that uses the TI products described in the resource. Other reproduction and display of these resources is prohibited. No license is granted to any other TI intellectual property right or to any third party intellectual property right. TI disclaims responsibility for, and you will fully indemnify TI and its representatives against, any claims, damages, costs, losses, and liabilities arising out of your use of these resources.

TI's products are provided subject to [TI's Terms of Sale](#) or other applicable terms available either on ti.com or provided in conjunction with such TI products. TI's provision of these resources does not expand or otherwise alter TI's applicable warranties or warranty disclaimers for TI products.

TI objects to and rejects any additional or different terms you may have proposed.

Mailing Address: Texas Instruments, Post Office Box 655303, Dallas, Texas 75265
Copyright © 2022, Texas Instruments Incorporated