

## 3.3-V PHASE-LOCK LOOP CLOCK DRIVER

Check for Samples: [CDCVF2509](#)

### FEATURES

- Use CDCVF2509A ([SCAS765](#)) as a Replacement for This Device
- Designed to Meet and Exceed PC133 SDRAM Registered DIMM Specification Rev. 1.1
- Spread Spectrum Clock Compatible
- Operating Frequency 50 MHz to 175 MHz
- Static Phase Error Distribution at 66 MHz to 166 MHz Is  $\pm 125$  ps
- Jitter (cyc - cyc) at 66 MHz to 166 MHz Is Typ = 70 ps
- Advanced Deep Submicron Process Results in More Than 40% Lower Power Consumption Versus Current Generation PC133 Devices
- Available in Plastic 24-Pin TSSOP
- Phase-Lock Loop Clock Distribution for Synchronous DRAM Applications
- Distributes One Clock Input to One Bank of Five and One Bank of Four Outputs
- Separate Output Enable for Each Output Bank
- External Feedback (FBIN) Terminal Is Used to Synchronize the Outputs to the Clock Input

- 25- $\Omega$  On-Chip Series Damping Resistors
- No External RC Network Required
- Operates at 3.3 V

### APPLICATIONS

- DRAM Applications
- PLL Based Clock Distributors
- Non-PLL Clock Buffer

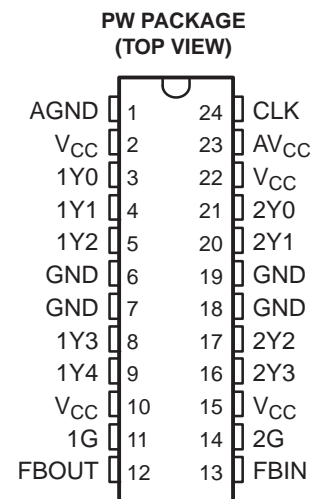

### DESCRIPTION

The CDCVF2509 is a high-performance, low-skew, low-jitter, phase-lock loop (PLL) clock driver. It uses a PLL to precisely align, in both frequency and phase, the feedback (FBOUT) output to the clock (CLK) input signal. It is specifically designed for use with synchronous DRAMs. The CDCVF2509 operates at a 3.3-V  $V_{CC}$ . It also provides integrated series-damping resistors that make it ideal for driving point-to-point loads.

One bank of five outputs and one bank of four outputs provide nine low-skew, low-jitter copies of CLK. Output signal duty cycles are adjusted to 50%, independent of the duty cycle at CLK. Each bank of outputs is enabled or disabled separately via the control (1G and 2G) inputs. When the G inputs are high, the outputs switch in phase and frequency with CLK; when the G inputs are low, the outputs are disabled to the logic-low state.

Unlike many products containing PLLs, the CDCVF2509 does not require external RC networks. The loop filter for the PLL is included on-chip, minimizing component count, board space, and cost.



Please be aware that an important notice concerning availability, standard warranty, and use in critical applications of Texas Instruments semiconductor products and disclaimers thereto appears at the end of this data sheet.



These devices have limited built-in ESD protection. The leads should be shorted together or the device placed in conductive foam during storage or handling to prevent electrostatic damage to the MOS gates.

## DESCRIPTION CONTINUED

Because it is based on PLL circuitry, the CDCVF2509 requires a stabilization time to achieve phase lock of the feedback signal to the reference signal. This stabilization time is required following power up and application of a fixed-frequency, fixed-phase signal at CLK, and following any changes to the PLL reference or feedback signals. The PLL can be bypassed by strapping  $AV_{CC}$  to ground.

The CDCVF2509A is characterized for operation from 0°C to 85°C.

For application information, see application reports *High Speed Distribution Design Techniques for CDC509/516/2509/2510/2516 (SLMA003)* and *Using CDC2509A/2510A PLL with Spread Spectrum Clocking (SSC) (SCAA039)*.

### FUNCTION TABLE

INPUTS			OUTPUTS		
1G	2G	CLK	1Y (0:4)	2Y (0:3)	FBOUT
X	X	L	L	L	L
L	L	H	L	L	H
L	H	H	L	H	H
H	L	H	H	L	H
H	H	H	H	H	H

### FUNCTIONAL BLOCK DIAGRAM

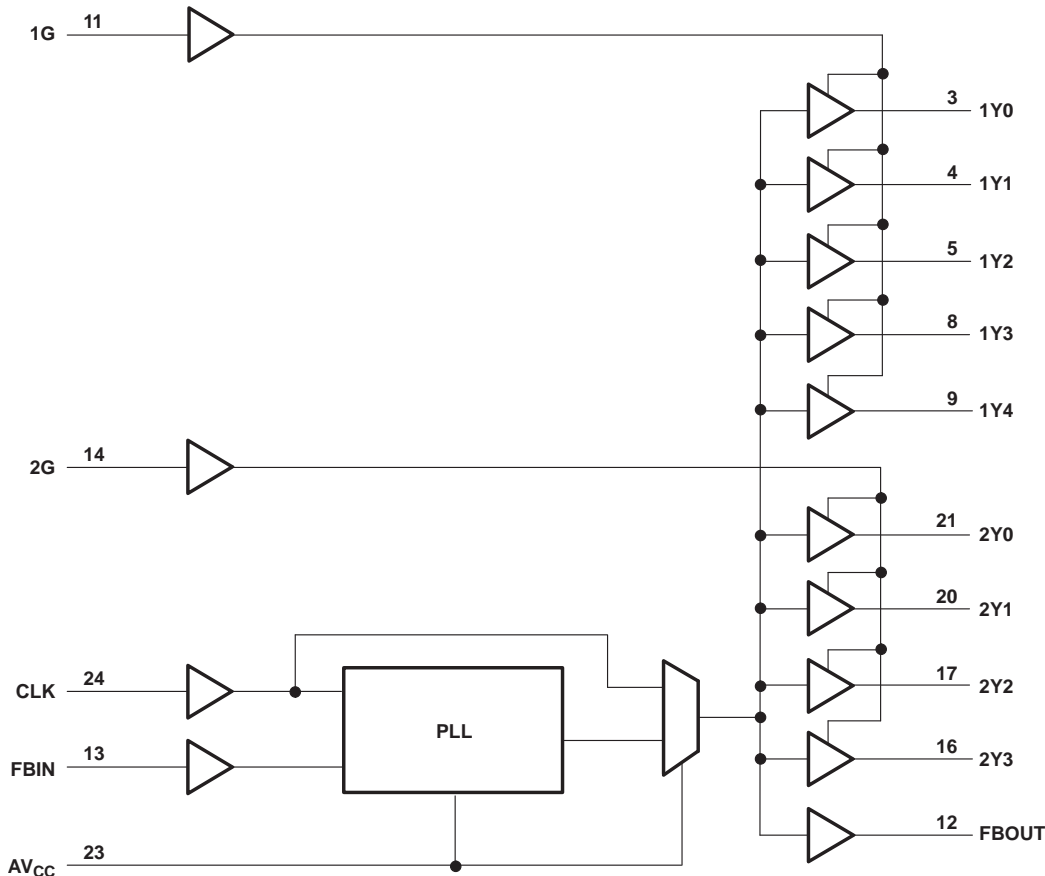

**AVAILABLE OPTIONS**

$T_A$	PACKAGE
	SMALL OUTLINE (PW)
0°C to 85°C	CDCVF2509PWR
	CDCVF2509PW

**PACKAGE THERMAL RESISTANCE<sup>(1)</sup>**

CDCVF2509APW 24-PIN TSSOP			THERMAL AIRFLOW (CFM)				UNIT
			0	150	250	500	
$R_{\theta JA}$	High K		88	83	81	77	°C/W
$R_{\theta JC}$	High K	26.5					

(1) The package thermal impedance is calculated in accordance with JESD 51 and JEDEC2S2P (high-k board).

**Pin Functions**

NAME	PIN NO.	TYPE	DESCRIPTION
CLK	24	I	Clock input. CLK provides the clock signal to be distributed by the CDCVF2509A clock driver. CLK is used to provide the reference signal to the integrated PLL that generates the clock output signals. CLK must have a fixed frequency and fixed phase for the PLL to obtain phase lock. Once the circuit is powered up and a valid CLK signal is applied, a stabilization time is required for the PLL to phase lock the feedback signal to its reference signal.
FBIN	13	I	Feedback input. FBIN provides the feedback signal to the internal PLL. FBIN must be hard-wired to FBOUT to complete the PLL. The integrated PLL synchronizes CLK and FBIN so that there is nominally zero phase error between CLK and FBIN.
1G	11	I	Output bank enable. 1G is the output enable for outputs 1Y(0:4). When 1G is low, outputs 1Y(0:4) are disabled to a logic-low state. When 1G is high, all outputs 1Y(0:4) are enabled and switch at the same frequency as CLK.
2G	14	I	Output bank enable. 2G is the output enable for outputs 2Y(0:3). When 2G is low, outputs 2Y(0:3) are disabled to a logic low state. When 2G is high, all outputs 2Y(0:3) are enabled and switch at the same frequency as CLK.
FBOUT	12	O	Feedback output. FBOUT is dedicated for external feedback. It switches at the same frequency as CLK. When externally wired to FBIN, FBOUT completes the feedback loop of the PLL. FBOUT has an integrated 25- $\Omega$ series-damping resistor.
1Y (0:4)	3, 4, 5, 8, 9	O	Clock outputs. These outputs provide low-skew copies of CLK. Output bank 1Y(0:4) is enabled via the 1G input. These outputs can be disabled to a logic-low state by deasserting the 1G control input. Each output has an integrated 25- $\Omega$ series-damping resistor.
2Y (0:3)	16, 17, 21, 20	O	Clock outputs. These outputs provide low-skew copies of CLK. Output bank 2Y(0:3) is enabled via the 2G input. These outputs can be disabled to a logic-low state by deasserting the 2G control input. Each output has an integrated 25- $\Omega$ series-damping resistor.
$AV_{CC}$	23	Power	Analog power supply. $AV_{CC}$ provides the power reference for the analog circuitry. In addition, $AV_{CC}$ can be used to bypass the PLL. When $AV_{CC}$ is strapped to ground, PLL is bypassed and CLK is buffered directly to the device outputs.
AGND	1	Ground	Analog ground. AGND provides the ground reference for the analog circuitry.
$V_{CC}$	2, 10, 15, 22	Power	Power supply
GND	6, 7, 18, 19	Ground	Ground

## ABSOLUTE MAXIMUM RATINGS

over operating free-air temperature range (unless otherwise noted)<sup>(1)</sup>

	UNIT
$AV_{CC}$ Supply voltage range <sup>(2)</sup>	$AV_{CC} < V_{CC} + 0.7\text{ V}$
$V_{CC}$ Supply voltage range	–0.5 V to 4.3 V
$V_I$ Input voltage range <sup>(3)</sup>	–0.5 V to 4.6 V
$V_O$ Voltage range applied to any output in the high or low state <sup>(3) (4)</sup>	–0.5 V to $V_{CC} + 0.5\text{ V}$
$I_{IK}$ Input clamp current ( $V_I < 0$ )	–50 mA
$I_{OK}$ Output clamp current ( $V_O < 0$ or $V_O > V_{CC}$ )	±50 mA
$I_O$ Continuous output current ( $V_O = 0$ to $V_{CC}$ )	±50 mA
Continuous current through each $V_{CC}$ or GND	±100 mA
Maximum power dissipation at $T_A = 55^\circ\text{C}$ (in still air) <sup>(5)</sup>	0.7 W
$T_{stg}$ Storage temperature range	–65°C to 150°C

- (1) Stresses beyond those listed under "absolute maximum ratings" may cause permanent damage to the device. These are stress ratings only, and functional operation of the device at these or any other conditions beyond those indicated under "recommended operating conditions" is not implied. Exposure to absolute-maximum-rated conditions for extended periods may affect device reliability.
- (2)  $AV_{CC}$  **must not** exceed  $V_{CC} + 0.7\text{ V}$
- (3) The input and output negative-voltage ratings may be exceeded if the input and output clamp-current ratings are observed.
- (4) This value is limited to 4.6 V maximum.
- (5) The maximum package power dissipation is calculated using a junction temperature of 150°C and a board trace length of 750 mils. For more information, see the *Package Thermal Considerations* application note in the *ABT Advanced BiCMOS Technology Data Book (SCBD002)*.

## DISSIPATION RATINGS

PACKAGE	BOARD TYPE	$R_{\theta JA}$	$T_A \leq 25^\circ\text{C}$ POWER RATING	DERATING FACTORS ABOVE $T_A \leq 25^\circ\text{C}$	$T_A = 70^\circ\text{C}$ POWER RATING	$T_A = 85^\circ\text{C}$ POWER RATING
PW	JEDEC low-K	114.5°C/W	920 mW	8.7 mW/°C	520 mW	390 mW
	JEDEC high-K	62.1°C/W	1690 mW	16.1 mW/°C	960 mW	720 mW

## RECOMMENDED OPERATING CONDITIONS<sup>(1)</sup>

	MIN	MAX	UNIT
$V_{CC}, AV_{CC}$ Supply voltage	3	3.6	V
$V_{IH}$ High-level input voltage	2		V
$V_{IL}$ Low-level input voltage		0.8	V
$V_I$ Input voltage	0	$V_{CC}$	V
$I_{OH}$ High-level output current		–12	mA
$I_{OL}$ Low-level output current		12	mA
$T_A$ Operating free-air temperature	0	85	°C

- (1) Unused inputs must be held high or low to prevent them from floating.

## TIMING REQUIREMENTS

over recommended ranges of supply voltage and operating free-air temperature

	MIN	MAX	UNIT
$f_{clk}$ Clock frequency	50	175	MHz
Input clock duty cycle	40%	60%	
Stabilization time <sup>(1)</sup>		1	ms

- (1) The time required for the integrated PLL circuit to obtain phase lock of its feedback signal to its reference signal. For phase lock to be obtained, a fixed-frequency, fixed-phase reference signal must be present at CLK. Until phase lock is obtained, the specifications for propagation delay, skew and jitter parameters given in the *switching characteristics* table are not applicable. This parameter does not apply for input modulation under SSC application.

## ELECTRICAL CHARACTERISTICS

over recommended operating free-air temperature range (unless otherwise noted)

PARAMETER		TEST CONDITIONS	V <sub>CC</sub> , AV <sub>CC</sub>	MIN	TYP <sup>(1)</sup>	MAX	UNIT
V <sub>IK</sub>	Input clamp voltage	I <sub>I</sub> = -18 mA	3 V			-1.2	V
V <sub>OH</sub>	High-level output voltage	I <sub>OH</sub> = -100 μA	MIN to MAX	V <sub>CC</sub> -0.2			V
		I <sub>OH</sub> = -12 mA	3 V	2.1			
		I <sub>OH</sub> = -6 mA	3 V	2.4			
V <sub>OL</sub>	Low-level output voltage	I <sub>OL</sub> = 100 μA	MIN to MAX			0.2	V
		I <sub>OL</sub> = 12 mA	3 V			0.8	
		I <sub>OL</sub> = 6 mA	3 V			0.55	
I <sub>OH</sub>	High-level output current	V <sub>O</sub> = 1 V	3 V	-28			mA
		V <sub>O</sub> = 1.65 V	3.3 V	-36			
		V <sub>O</sub> = 3.135 V	3.6 V	-8			
I <sub>OL</sub>	Low-level output current	V <sub>O</sub> = 1.95 V	3 V	30			mA
		V <sub>O</sub> = 1.65 V	3.3 V	40			
		V <sub>O</sub> = 0.4 V	3.6 V	10			
I <sub>I</sub>	Input current	V <sub>I</sub> = V <sub>CC</sub> or GND	3.6 V			±5	μA
I <sub>CC</sub> <sup>(2)</sup>	Supply current (static, output not switching)	V <sub>I</sub> = V <sub>CC</sub> or GND, I <sub>O</sub> = 0, Outputs: low or high	3.6 V, 0 V			40	μA
ΔI <sub>CC</sub>	Change in supply current	One input at V <sub>CC</sub> - 0.6 V, Other inputs at V <sub>CC</sub> or GND	3.3 V to 3.6 V			500	μA
C <sub>i</sub>	Input capacitance	V <sub>I</sub> = V <sub>CC</sub> or GND	3.3 V		2.5		pF
C <sub>o</sub>	Output capacitance	V <sub>O</sub> = V <sub>CC</sub> or GND	3.3 V		2.8		pF

(1) For conditions shown as MIN or MAX, use the appropriate value specified under the *recommended operating conditions* section.

(2) For dynamic I<sub>CC</sub> vs Frequency, see [Figure 8](#) and [Figure 9](#).

## SWITCHING CHARACTERISTICS

over recommended ranges of supply voltage and operating free-air temperature, C<sub>L</sub> = 25 pF (see [Figure 1](#) and [Figure 2](#))<sup>(1) (2)</sup>

PARAMETER	FROM (INPUT)	TO (OUTPUT)	V <sub>CC</sub> , AV <sub>CC</sub> = 3.3 V ± 0.3 V			UNIT
			MIN	TYP	MAX	
t <sub>(φ)</sub>	Phase error time- static (normalized) (see <a href="#">Figure 3</a> through <a href="#">Figure 6</a> )	CLK↑ = 66 MHz to 166 MHz	FBIN↑	-125	125	ps
t <sub>sk(o)</sub>	Output skew time <sup>(3)</sup>	Any Y	Any Y		100	ps
	Phase error time-jitter <sup>(4)</sup>	CLK = 66 MHz to 100 MHz	Any Y or FBOUT	-50	50	ps
	Jitter <sub>(cycle-cycle)</sub> (see <a href="#">Figure 7</a> )	CLK = 66 MHz to 100 MHz	Any Y or FBOUT	-70		ps
		CLK = 100 MHz to 166 MHz		-65		
	Duty cycle	f <sub>(CLK)</sub> > 60 MHz	Any Y or FBOUT	45%	55%	
t <sub>r</sub>	Rise time	V <sub>O</sub> = 0.4 V to 2 V	Any Y or FBOUT	0.3	1.1	ns/V
t <sub>f</sub>	Fall time	V <sub>O</sub> = 2 V to 0.4 V	Any Y or FBOUT	0.3	1.1	ns/V
t <sub>PLH</sub>	Low-to-high propagation delay time, bypass mode	CLK	Any Y or FBOUT	1.8	3.9	ns
t <sub>PHL</sub>	High-to-low propagation delay time, bypass mode	CLK	Any Y or FBOUT	1.8	3.9	ns

(1) The specifications for parameters in this table are applicable only after any appropriate stabilization time has elapsed.

(2) These parameters are not production tested.

(3) The t<sub>sk(o)</sub> specification is only valid for equal loading of all outputs.

(4) Calculated per PC DRAM SPEC (t<sub>phase error</sub>, static-jitter<sub>(cycle-to-cycle)</sub>).

**PARAMETER MEASUREMENT INFORMATION**

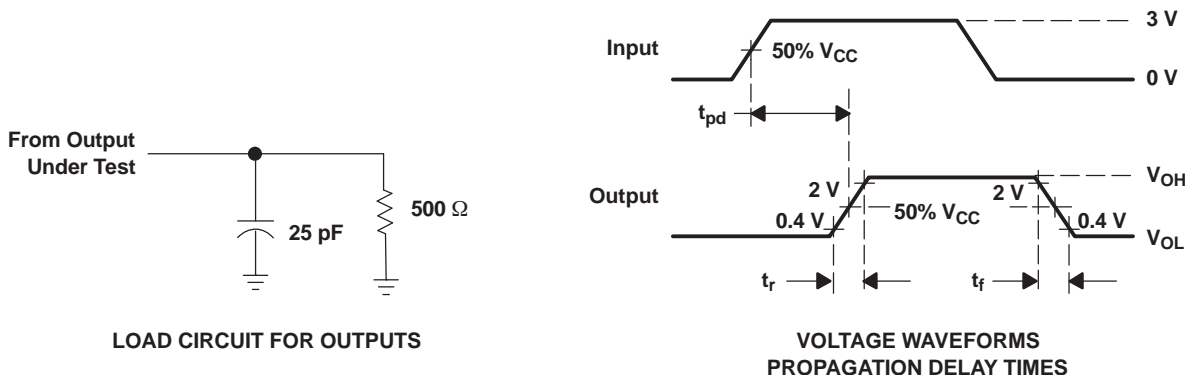

- NOTES: A.  $C_L$  includes probe and jig capacitance.  
 B. All input pulses are supplied by generators having the following characteristics: PRR  $\leq$  133 MHz,  $Z_O = 50 \Omega$ ,  $t_r \leq 1.2$  ns,  $t_f \leq 1.2$  ns.  
 C. The outputs are measured one at a time with one transition per measurement.

**Figure 1. Load Circuit and Voltage Waveforms**

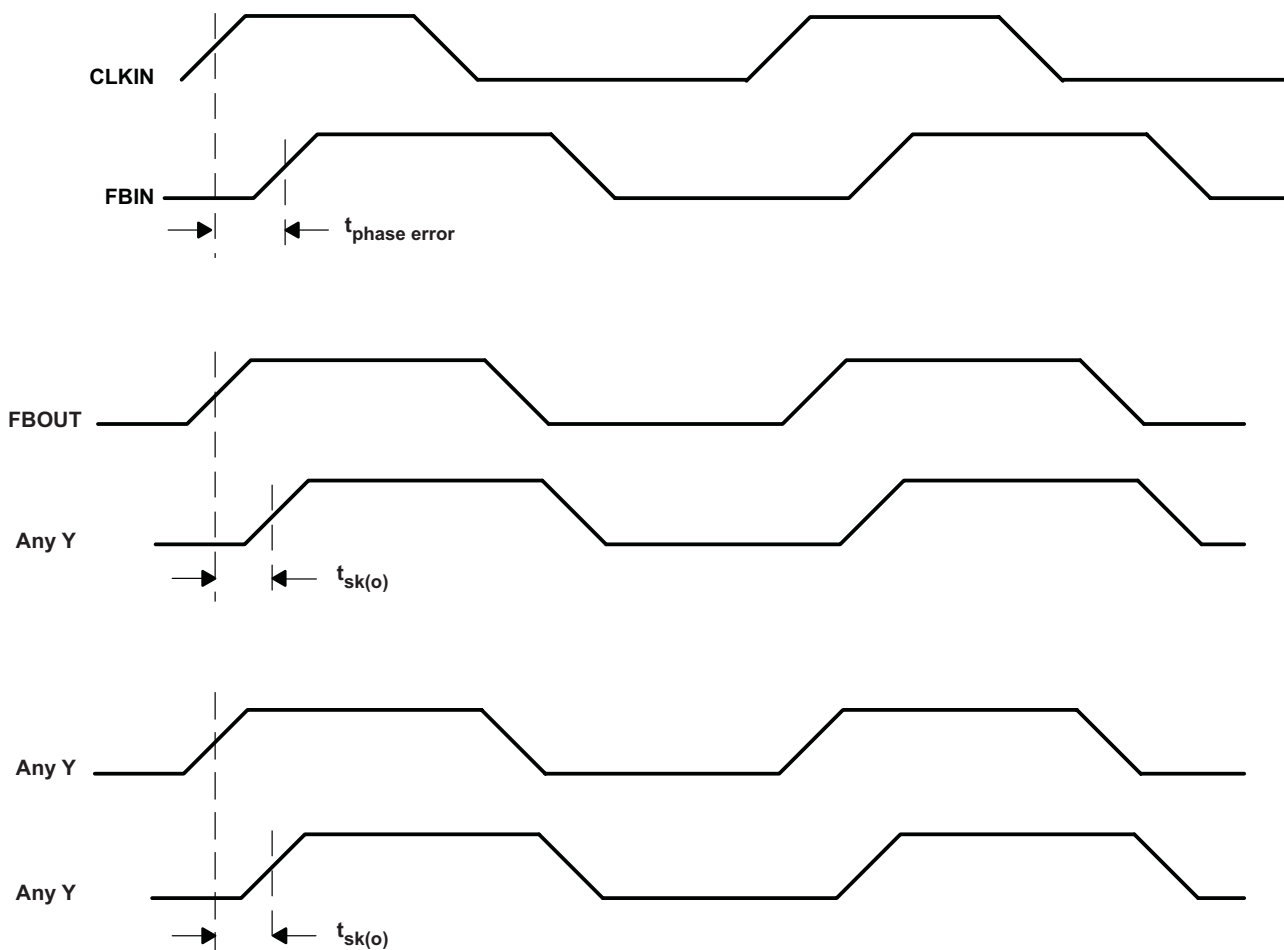

**Figure 2. Skew Calculations**

**TYPICAL CHARACTERISTICS**

**STATIC PHASE ERROR  
vs  
LOAD CAPACITANCE**

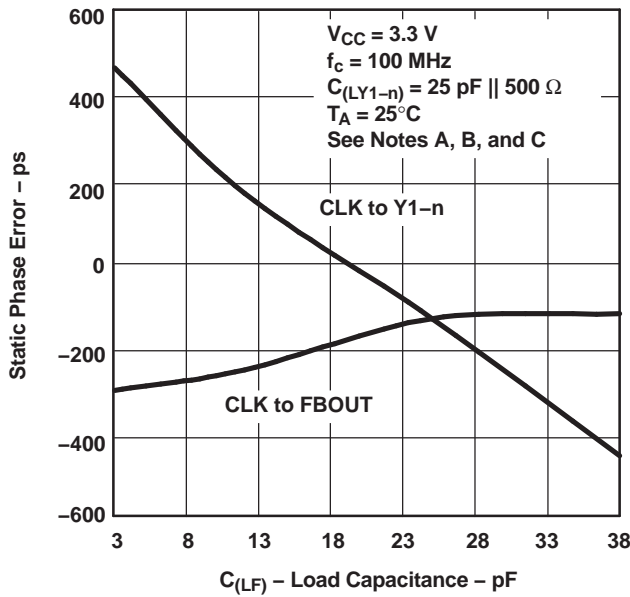

Figure 3.

**STATIC PHASE ERROR  
vs  
LOAD CAPACITANCE**

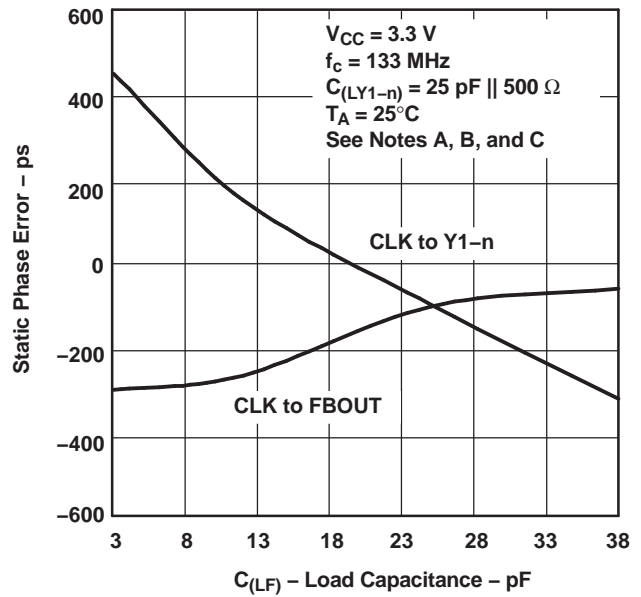

Figure 4.

**STATIC PHASE ERROR  
vs  
SUPPLY VOLTAGE AT FBOUT**

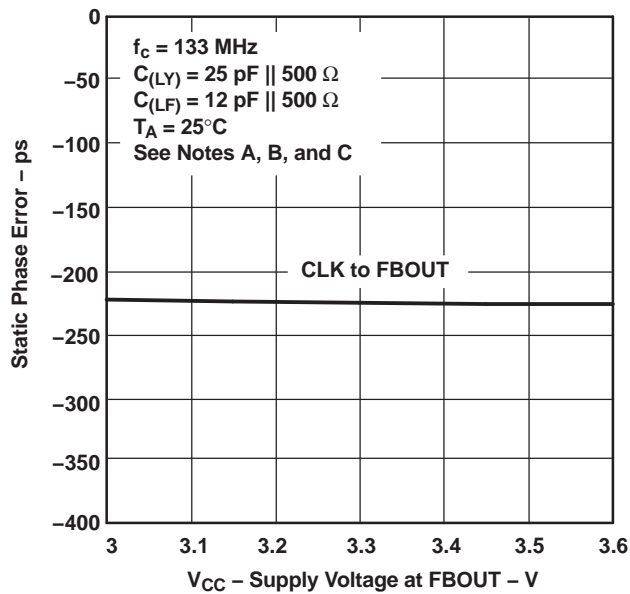

Figure 5.

**STATIC PHASE ERROR  
vs  
CLOCK FREQUENCY**

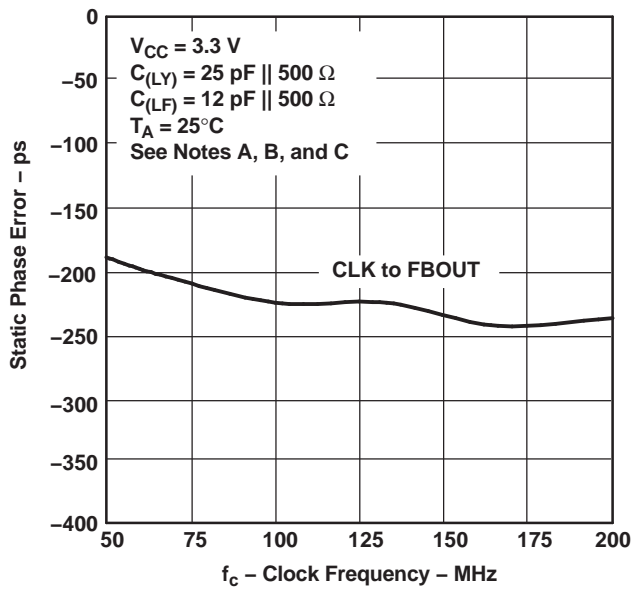

Figure 6.

- a. Trace length FBOUT to FBIN = 5 mm,  $Z_0 = 50\ \Omega$
- b.  $C_{(LY)}$  = Lumped capacitive load  $Y_{1-n}$
- c.  $C_{(LFx)}$  = Lumped feedback capacitance at FBOUT = FBIN

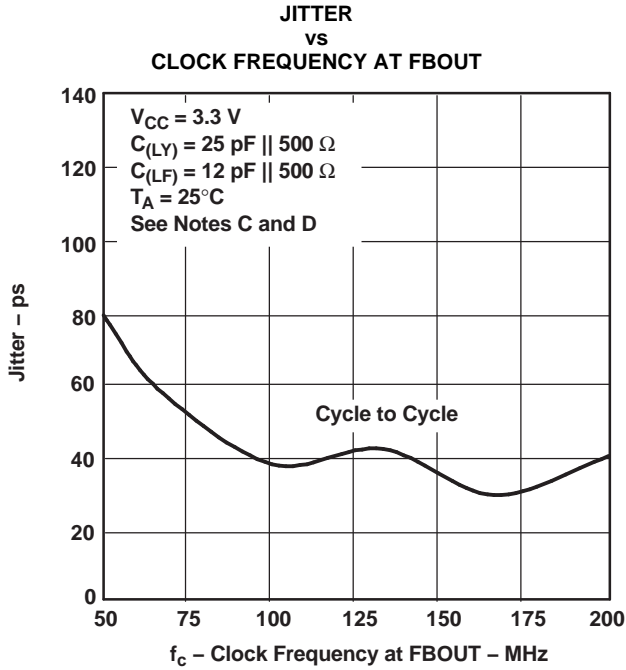

Figure 7.

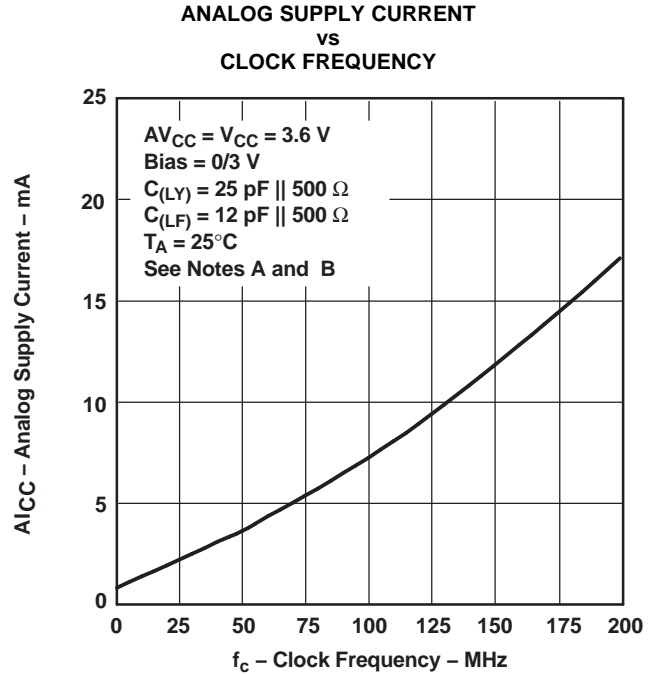

Figure 8.

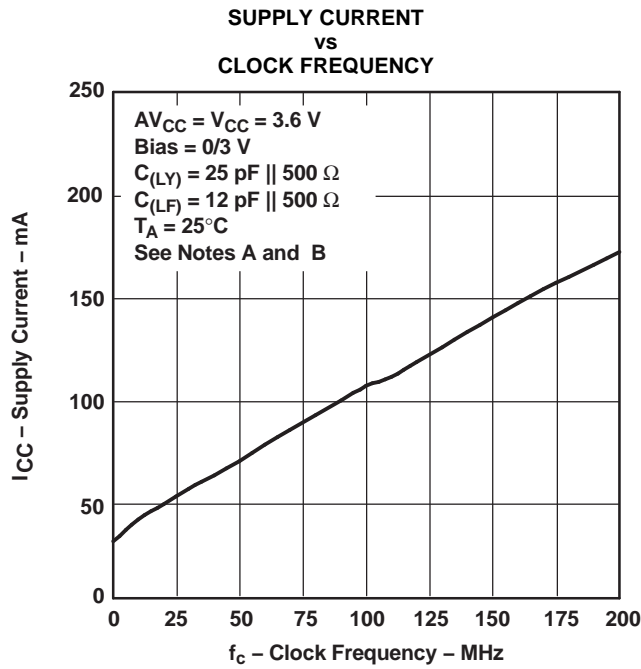

Figure 9.

- a. Trace length FBOUT to FBIN = 5 mm,  $Z_0 = 50\ \Omega$
- b.  $C_{(LY)}$  = Lumped capacitive load  $Y_{1-n}$
- c.  $C_{(LFx)}$  = Lumped feedback capacitance at FBOUT = FBIN
- d.  $C_{(LFx)}$  = Lumped feedback capacitance at FBOUT = FBIN.

**REVISION HISTORY****Changes from Original (April 2004) to Revision A** **Page**

- Added CDCVF2509PW package number to the AVAILABLE OPTIONS table ..... **3**

**Changes from Revision A (July 2004) to Revision B** **Page**

- Changed Rise time values in the Switching Characteristics table From: Min = 0.5 Max = 2.5 To: Min = 0.3 Max = 1.1 ..... **5**
- Changed Fall time values in the Switching Characteristics table From: Min = 0.5 Max = 2.5 To: Min = 0.3 Max = 1.1 ..... **5**
- Changed Low-to-high propagation delay time values in the Switching Characteristics table From: Min = 0.4 Max = 2.3 To: Min = 1.8 Max = 3.9 ..... **5**
- Changed High-to-low propagation delay time values in the Switching Characteristics table From: Min = 0.4 Max = 2.3 To: Min = 1.8 Max = 3.9 ..... **5**

**Changes from Revision B (June 2005) to Revision C** **Page**

- Added NOT RECOMMENDED FOR NEW DESIGNS ..... **1**

**Changes from Revision C (January 2009) to Revision D** **Page**

- Added the PACKAGE THERMAL RESISTANCE table ..... **3**

**PACKAGING INFORMATION**

Orderable Device	Status (1)	Package Type	Package Drawing	Pins	Package Qty	Eco Plan (2)	Lead finish/ Ball material (6)	MSL Peak Temp (3)	Op Temp (°C)	Device Marking (4/5)	Samples
CDCVF2509PW	ACTIVE	TSSOP	PW	24	60	RoHS & Green	NIPDAU	Level-1-260C-UNLIM	0 to 85	CKV2509	Samples
CDCVF2509PWG4	ACTIVE	TSSOP	PW	24	60	TBD	Call TI	Call TI	0 to 85		Samples
CDCVF2509PWR	ACTIVE	TSSOP	PW	24	2000	RoHS & Green	NIPDAU	Level-1-260C-UNLIM	0 to 85	CKV2509	Samples
CDCVF2509PWRG4	ACTIVE	TSSOP	PW	24	2000	TBD	Call TI	Call TI	0 to 85		Samples

(1) The marketing status values are defined as follows:

**ACTIVE:** Product device recommended for new designs.

**LIFEBUY:** TI has announced that the device will be discontinued, and a lifetime-buy period is in effect.

**NRND:** Not recommended for new designs. Device is in production to support existing customers, but TI does not recommend using this part in a new design.

**PREVIEW:** Device has been announced but is not in production. Samples may or may not be available.

**OBSELETE:** TI has discontinued the production of the device.

(2) **RoHS:** TI defines "RoHS" to mean semiconductor products that are compliant with the current EU RoHS requirements for all 10 RoHS substances, including the requirement that RoHS substance do not exceed 0.1% by weight in homogeneous materials. Where designed to be soldered at high temperatures, "RoHS" products are suitable for use in specified lead-free processes. TI may reference these types of products as "Pb-Free".

**RoHS Exempt:** TI defines "RoHS Exempt" to mean products that contain lead but are compliant with EU RoHS pursuant to a specific EU RoHS exemption.

**Green:** TI defines "Green" to mean the content of Chlorine (Cl) and Bromine (Br) based flame retardants meet JS709B low halogen requirements of <=1000ppm threshold. Antimony trioxide based flame retardants must also meet the <=1000ppm threshold requirement.

(3) MSL, Peak Temp. - The Moisture Sensitivity Level rating according to the JEDEC industry standard classifications, and peak solder temperature.

(4) There may be additional marking, which relates to the logo, the lot trace code information, or the environmental category on the device.

(5) Multiple Device Markings will be inside parentheses. Only one Device Marking contained in parentheses and separated by a "-" will appear on a device. If a line is indented then it is a continuation of the previous line and the two combined represent the entire Device Marking for that device.

(6) Lead finish/Ball material - Orderable Devices may have multiple material finish options. Finish options are separated by a vertical ruled line. Lead finish/Ball material values may wrap to two lines if the finish value exceeds the maximum column width.

**Important Information and Disclaimer:**The information provided on this page represents TI's knowledge and belief as of the date that it is provided. TI bases its knowledge and belief on information provided by third parties, and makes no representation or warranty as to the accuracy of such information. Efforts are underway to better integrate information from third parties. TI has taken and

continues to take reasonable steps to provide representative and accurate information but may not have conducted destructive testing or chemical analysis on incoming materials and chemicals. TI and TI suppliers consider certain information to be proprietary, and thus CAS numbers and other limited information may not be available for release.

In no event shall TI's liability arising out of such information exceed the total purchase price of the TI part(s) at issue in this document sold by TI to Customer on an annual basis.

**TAPE AND REEL INFORMATION**

**QUADRANT ASSIGNMENTS FOR PIN 1 ORIENTATION IN TAPE**



\*All dimensions are nominal

Device	Package Type	Package Drawing	Pins	SPQ	Reel Diameter (mm)	Reel Width W1 (mm)	A0 (mm)	B0 (mm)	K0 (mm)	P1 (mm)	W (mm)	Pin1 Quadrant
CDCVF2509PWR	TSSOP	PW	24	2000	330.0	16.4	6.95	8.3	1.6	8.0	16.0	Q1

**TAPE AND REEL BOX DIMENSIONS**

\*All dimensions are nominal

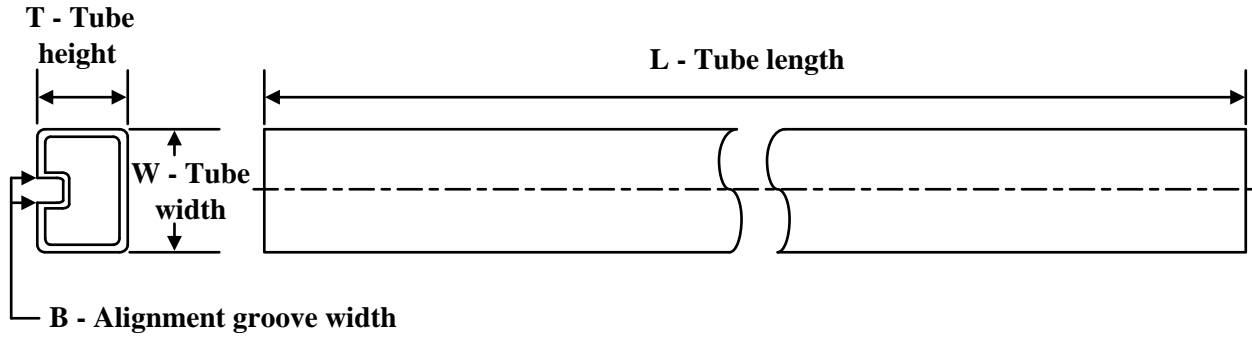
Device	Package Type	Package Drawing	Pins	SPQ	Length (mm)	Width (mm)	Height (mm)
CDCVF2509PWR	TSSOP	PW	24	2000	356.0	356.0	35.0

**TUBE**

\*All dimensions are nominal

Device	Package Name	Package Type	Pins	SPQ	L (mm)	W (mm)	T (μm)	B (mm)
CDCVF2509PW	PW	TSSOP	24	60	530	10.2	3600	3.5

PW0024A



# PACKAGE OUTLINE

## TSSOP - 1.2 mm max height

SMALL OUTLINE PACKAGE



4220208/A 02/2017

NOTES:

1. All linear dimensions are in millimeters. Any dimensions in parenthesis are for reference only. Dimensioning and tolerancing per ASME Y14.5M.
2. This drawing is subject to change without notice.
3. This dimension does not include mold flash, protrusions, or gate burrs. Mold flash, protrusions, or gate burrs shall not exceed 0.15 mm per side.
4. This dimension does not include interlead flash. Interlead flash shall not exceed 0.25 mm per side.
5. Reference JEDEC registration MO-153.

# EXAMPLE BOARD LAYOUT

PW0024A

TSSOP - 1.2 mm max height

SMALL OUTLINE PACKAGE

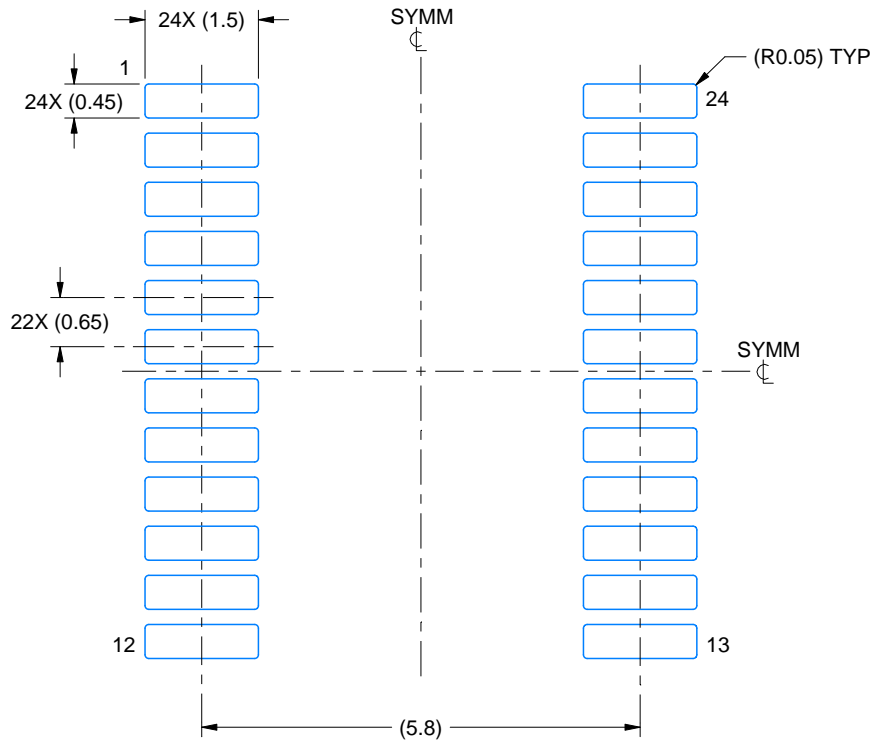

LAND PATTERN EXAMPLE  
EXPOSED METAL SHOWN  
SCALE: 10X



SOLDER MASK DETAILS

4220208/A 02/2017

NOTES: (continued)

- 6. Publication IPC-7351 may have alternate designs.
- 7. Solder mask tolerances between and around signal pads can vary based on board fabrication site.

# EXAMPLE STENCIL DESIGN

PW0024A

TSSOP - 1.2 mm max height

SMALL OUTLINE PACKAGE



NOTES: (continued)

8. Laser cutting apertures with trapezoidal walls and rounded corners may offer better paste release. IPC-7525 may have alternate design recommendations.
9. Board assembly site may have different recommendations for stencil design.

## IMPORTANT NOTICE AND DISCLAIMER

TI PROVIDES TECHNICAL AND RELIABILITY DATA (INCLUDING DATA SHEETS), DESIGN RESOURCES (INCLUDING REFERENCE DESIGNS), APPLICATION OR OTHER DESIGN ADVICE, WEB TOOLS, SAFETY INFORMATION, AND OTHER RESOURCES "AS IS" AND WITH ALL FAULTS, AND DISCLAIMS ALL WARRANTIES, EXPRESS AND IMPLIED, INCLUDING WITHOUT LIMITATION ANY IMPLIED WARRANTIES OF MERCHANTABILITY, FITNESS FOR A PARTICULAR PURPOSE OR NON-INFRINGEMENT OF THIRD PARTY INTELLECTUAL PROPERTY RIGHTS.

These resources are intended for skilled developers designing with TI products. You are solely responsible for (1) selecting the appropriate TI products for your application, (2) designing, validating and testing your application, and (3) ensuring your application meets applicable standards, and any other safety, security, regulatory or other requirements.

These resources are subject to change without notice. TI grants you permission to use these resources only for development of an application that uses the TI products described in the resource. Other reproduction and display of these resources is prohibited. No license is granted to any other TI intellectual property right or to any third party intellectual property right. TI disclaims responsibility for, and you will fully indemnify TI and its representatives against, any claims, damages, costs, losses, and liabilities arising out of your use of these resources.

TI's products are provided subject to [TI's Terms of Sale](#) or other applicable terms available either on [ti.com](http://ti.com) or provided in conjunction with such TI products. TI's provision of these resources does not expand or otherwise alter TI's applicable warranties or warranty disclaimers for TI products.

TI objects to and rejects any additional or different terms you may have proposed.

Mailing Address: Texas Instruments, Post Office Box 655303, Dallas, Texas 75265  
Copyright © 2022, Texas Instruments Incorporated