

16-Bit Registered Transceivers

Features

- I_{off} supports partial-power-down mode operation
- Edge-rate control circuitry for significantly improved noise characteristics
- Typical output skew < 250 ps
- ESD > 2000V
- TSSOP (19.6-mil pitch) and SSOP (25-mil pitch) packages
- Industrial temperature range of -40°C to $+85^{\circ}\text{C}$
- $V_{CC} = 5\text{V} \pm 10\%$

CY74FCT16646T Features:

- 64 mA sink current, 32 mA source current
- Typical V_{OLP} (ground bounce) < 1.0V at $V_{CC} = 5\text{V}$, $T_A = 25^{\circ}\text{C}$

CY74FCT162646T Features:

- Balanced 24 mA output drivers
- Reduced system switching noise
- Typical V_{OLP} (ground bounce) < 0.6V at $V_{CC} = 5\text{V}$, $T_A = 25^{\circ}\text{C}$

Functional Description

The CY74FCT16646T and CY74FCT162646T 16-bit transceivers are three-state, D-type registers, and control circuitry arranged for multiplexed transmission of data directly from the input bus or from the internal registers. Data on the A or B bus will be clocked into the registers as the appropriate clock pin goes to a HIGH logic level. Output Enable ($\overline{\text{OE}}$) and direction pins (DIR) are provided to control the transceiver function. In the transceiver mode, data present at the high impedance port may be stored in either the A or B register, or in both. The select controls can multiplex stored and real-time (transparent mode) data. The direction control determines which bus will receive data when the Output Enable ($\overline{\text{OE}}$) is Active LOW. In the isolation mode (Output Enable ($\overline{\text{OE}}$) HIGH), A data may be stored in the B register and/or B data may be stored in the A register.

This device is fully specified for partial-power-down applications using I_{off} . The I_{off} circuitry disables the outputs, preventing damaging current backflow through the device when it is powered down.

The CY74FCT16646T is ideally suited for driving high-capacitance loads and low-impedance backplanes.

The CY74FCT162646T has 24-mA balanced output drivers with current limiting resistors in the outputs. This reduces the need for external terminating resistors and provides for minimal undershoot and reduced ground bounce. The CY74FCT162646T is ideal for driving transmission lines.

Logic Block Diagrams

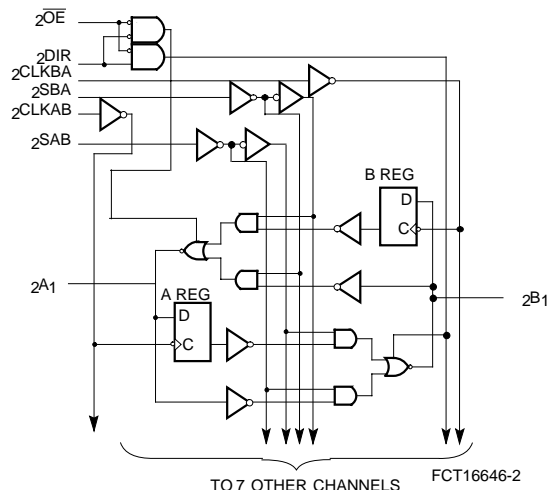
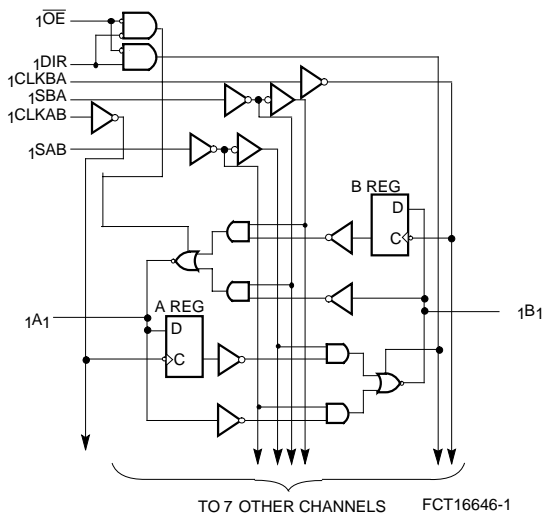

Pin Configuration

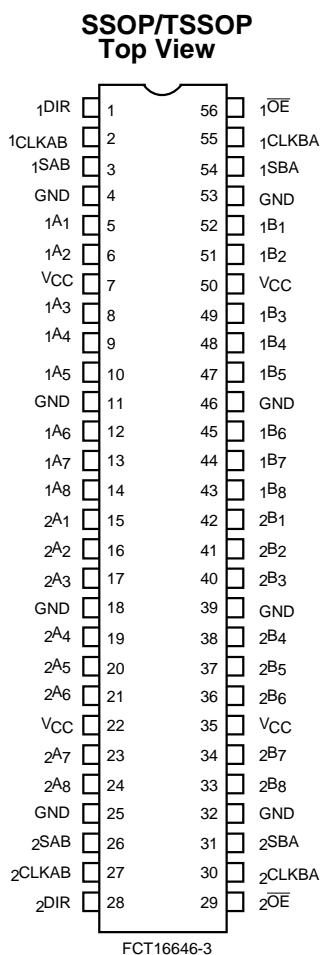

Pin Description

Pin Names	Description
A	Data Register A Inputs Data Register B Outputs
B	Data Register B Inputs Data Register A Outputs
CLKAB, CLKBA	Clock Pulse Inputs
SAB, SBA	Output Data Source Select Inputs
DIR	Direction
\overline{OE}	Output Enable (Active LOW)

Function Table^[1]

Inputs						Data I/O ^[2]		Function
\overline{OE}	DIR	CLKAB	CLKBA	SAB	SBA	A	B	
H	X	H or L	H or L	X	X	Input	Input	Isolation
H	X	┐	┐	X	X			Store A and B Data
L	L	X	X	X	L	Output	Input	Real Time B Data to A Bus
L	L	X	H or L	X	H			Stored B Data to A Bus
L	H	X	X	L	X	Input	Output	Real Time A Data to Bus
L	H	H or L	X	H	X			Stored A Data to B Bus

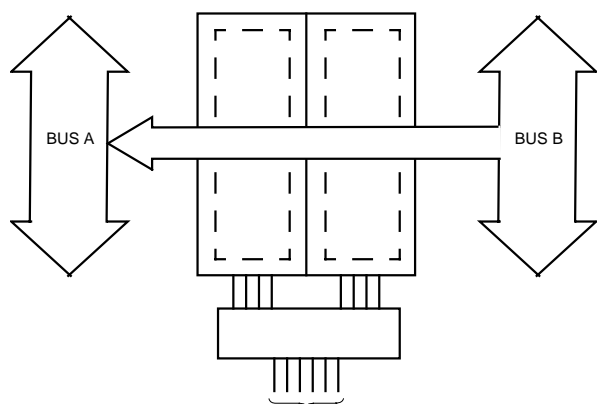

DIR L \overline{OE} L CLKAB X CLKBA X SAB X SBA L

Real-Time Transfer
Bus B to Bus A

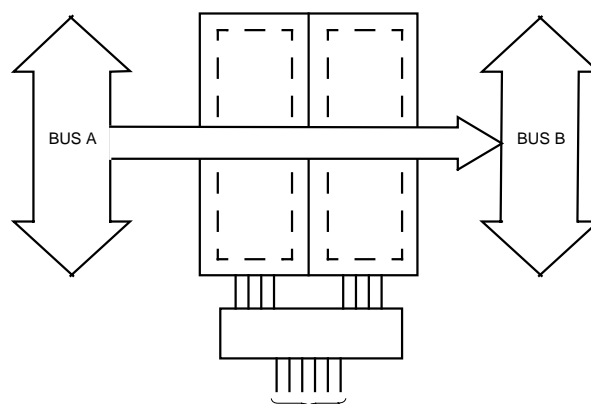

DIR H \overline{OE} L CLKAB X CLKBA X SAB L SBA X

Real-Time Transfer
Bus A to Bus B

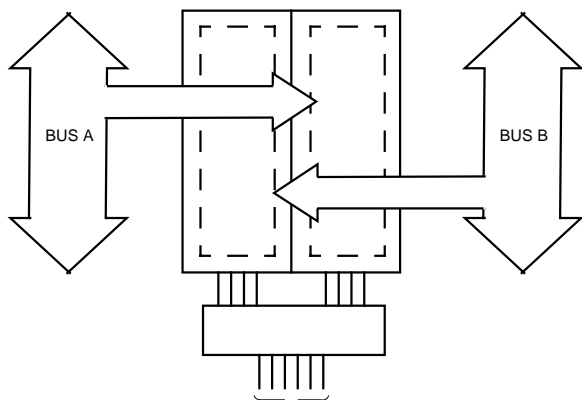

DIR H L X \overline{OE} L L H CLKAB ┐ X ┐ CLKBA X ┐ SAB X X X SBA X X X

Storage from
A and/or B

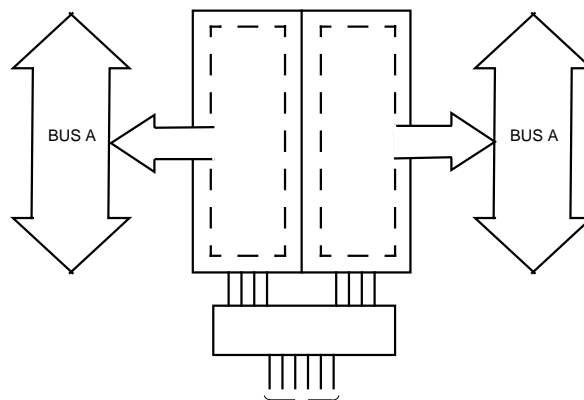

DIR^[3] L H \overline{OE} L L CLKAB X H or L CLKBA H or L X SAB X H SBA H X

Transfer Stored Data
to A and/or B

Notes:

1. H = HIGH Voltage Level. L = LOW Voltage Level. X = Don't Care ┐ = LOW-to-HIGH Transition
2. The data output functions may be enabled or disabled by various signals at the \overline{OE} or DIR inputs. Data input functions are always enabled, i.e., data at the bus pins will be stored on every LOW-to-HIGH transition on the clock inputs.
3. Cannot transfer data to A-bus and B-bus simultaneously.

Maximum Ratings^[4]

(Above which the useful life may be impaired. For user guidelines, not tested.)

Storage TemperatureCom'l -55°C to +125°C

Ambient Temperature with
Power AppliedCom'l -55°C to +125°C

DC Input Voltage-0.5V to +7.0V

DC Output Voltage-0.5V to +7.0V

DC Output Current
(Maximum Sink Current/Pin)-60 to +120 mA

Power Dissipation 1.0W

Static Discharge Voltage.....>2001V
(per MIL-STD-883, Method 3015)

Operating Range

Range	Ambient Temperature	V _{CC}
Industrial	-40°C to +85°C	5V ± 10%

Electrical Characteristics Over the Operating Range

Parameter	Description	Test Conditions	Min.	Typ. ^[5]	Max.	Unit
V _{IH}	Input HIGH Voltage		2.0			V
V _{IL}	Input LOW Voltage				0.8	V
V _H	Input Hysteresis ^[6]			100		mV
V _{IK}	Input Clamp Diode Voltage	V _{CC} =Min., I _{IN} =-18 mA		-0.7	-1.2	V
I _{IH}	Input HIGH Current	V _{CC} =Max., V _I =V _{CC}			±1	μA
I _{IL}	Input LOW Current	V _{CC} =Max., V _I =GND			±1	μA
I _{OZH}	High Impedance Output Current (Three-State Output pins)	V _{CC} =Max., V _{OUT} =2.7V			±1	μA
I _{OZL}	High Impedance Output Current (Three-State Output pins)	V _{CC} =Max., V _{OUT} =0.5V			±1	μA
I _{OS}	Short Circuit Current ^[7]	V _{CC} =Max., V _{OUT} =GND	-80	-140	-200	mA
I _O	Output Drive Current ^[7]	V _{CC} =Max., V _{OUT} =2.5V	-50		-180	mA
I _{OFF}	Power-Off Disable	V _{CC} =0V, V _{OUT} ≤4.5V ^[9]			±1	μA

Output Drive Characteristics for CY74FCT16646T

Parameter	Description	Test Conditions	Min.	Typ. ^[5]	Max.	Unit
V _{OH}	Output HIGH Voltage	V _{CC} =Min., I _{OH} =-3 mA	2.5	3.5		V
		V _{CC} =Min., I _{OH} =-15 mA	2.4	3.5		V
		V _{CC} =Min., I _{OH} =-32 mA	2.0	3.0		V
V _{OL}	Output LOW Voltage	V _{CC} =Min., I _{OL} =64 mA		0.2	0.55	V

Output Drive Characteristics for CY74FCT162646T

Parameter	Description	Test Conditions	Min.	Typ. ^[5]	Max.	Unit
I _{ODL}	Output LOW Current ^[7]	V _{CC} =5V, V _{IN} =V _{IH} or V _{IL} , V _{OUT} =1.5V	60	115	150	mA
I _{ODH}	Output HIGH Current ^[7]	V _{CC} =5V, V _{IN} =V _{IH} or V _{IL} , V _{OUT} =1.5V	-60	-115	-150	mA
V _{OH}	Output HIGH Voltage	V _{CC} =Min., I _{OH} =-24 mA	2.4	3.3		V
V _{OL}	Output LOW Voltage	V _{CC} =Min., I _{OL} =24 mA		0.3	0.55	V

Notes:

- Stresses greater than those listed under Maximum Ratings may cause permanent damage to the device. This is a stress rating only and functional operation of the device at these or any other conditions above those indicated in the operational sections of this specification is not implied. Exposure to absolute maximum rating conditions for extended periods may affect reliability.
- Typical values are at V_{CC}= 5.0V, T_A= +25°C ambient.
- This parameter is specified but not tested.
- Not more than one output should be shorted at a time. Duration of short should not exceed one second. The use of high-speed test apparatus and/or sample and hold techniques are preferable in order to minimize internal chip heating and more accurately reflect operational values. Otherwise prolonged shorting of a high output may raise the chip temperature well above normal and thereby cause invalid readings in other parametrics tests. In any sequence of parameter tests, I_{OS} tests should be performed last.
- This parameter is measured at characterization but not tested.
- Tested at +25°C.

Capacitance ($T_A = +25^\circ\text{C}$, $f = 1.0\text{ MHz}$)

Symbol	Description ^[8]	Conditions	Typ.	Max.	Unit
C_{IN}	Input Capacitance	$V_{IN} = 0V$	4.5	6.0	pF
C_{OUT}	Output Capacitance	$V_{OUT} = 0V$	5.5	8.0	pF

Power Supply Characteristics

Parameter	Description	Test Conditions ^[10]	Min.	Typ. ^[5]	Max.	Unit	
I_{CC}	Quiescent Power Supply Current	$V_{CC} = \text{Max.}$	$V_{IN} \leq 0.2V$ $V_{IN} \geq V_{CC} - 0.2V$	—	5	500 μA	
ΔI_{CC}	Quiescent Power Supply Current TTL Inputs HIGH	$V_{CC} = \text{Max.}$ $V_{IN} = 3.4V$ ^[11]	—	0.5	1.5	mA	
I_{CCD}	Dynamic Power Supply Current ^[12]	$V_{CC} = \text{Max.}$ Outputs Open DIR=OE=GND One-Bit Toggling 50% Duty Cycle	$V_{IN} = V_{CC}$ or $V_{IN} = \text{GND}$	—	75	120 $\mu\text{A}/\text{MHz}$	
I_C	Total Power Supply Current ^[13]	$V_{CC} = \text{Max.}$ Outputs Open $f_0 = 10\text{ MHz}$ (CLKBA) 50% Duty Cycle DIR=OE=GND One-Bit Toggling $f_1 = 5\text{ MHz}$ 50% Duty Cycle	$V_{IN} = V_{CC}$ or $V_{IN} = \text{GND}$	—	0.8	1.7	mA
			$V_{IN} = 3.4V$ or $V_{IN} = \text{GND}$	—	1.3	3.2	
		$V_{CC} = \text{Max.}$ Outputs Open $f_0 = 10\text{ MHz}$ (CLKBA) 50% Duty Cycle DIR=OE=GND Sixteen-Bits Toggling $f_1 = 2.5\text{ MHz}$ 50% Duty Cycle	$V_{IN} = V_{CC}$ or $V_{IN} = \text{GND}$	—	3.8	6.5 ^[14]	
			$V_{IN} = 3.4V$ or $V_{IN} = \text{GND}$	—	8.3	20.0 ^[14]	

Notes:

10. For conditions shown as Max. or Min., use appropriate value specified under Electrical Characteristics for the applicable device type.
11. Per TTL driven input ($V_{IN} = 3.4V$); all other inputs at V_{CC} or GND.
12. This parameter is not directly testable, but is derived for use in Total Power Supply calculations.
13. $I_C = I_{QUIESCENT} + I_{INPUTS} + I_{DYNAMIC}$
 $I_C = I_{CC} + \Delta I_{CC} D_H N_T + I_{CCD} (f_0/2 + f_1 N_1)$
 I_{CC} = Quiescent Current with CMOS input levels
 ΔI_{CC} = Power Supply Current for a TTL HIGH input ($V_{IN} = 3.4V$)
 D_H = Duty Cycle for TTL inputs HIGH
 N_T = Number of TTL inputs at D_H
 I_{CCD} = Dynamic Current caused by an input transition pair (HLH or LHL)
 f_0 = Clock frequency for registered devices, otherwise zero
 f_1 = Input signal frequency
 N_1 = Number of inputs changing at f_1
 All currents are in milliamps and all frequencies are in megahertz.
14. Values for these conditions are examples of the I_{CC} formula. These limits are specified but not tested.

Switching Characteristics Over the Operating Range^[15]

Parameter	Description	CY74FCT16646T		CY74FCT16646AT CY74FCT162646AT		Unit	Fig. No. ^[16]
		Min.	Max.	Min.	Max.		
t _{PLH} t _{PHL}	Propagation Delay Bus to Bus	1.5	9.0	1.5	6.3	ns	1, 2
t _{PZH} t _{PZL}	Output Enable Time DIR or OE to Bus	1.5	14.0	1.5	9.8	ns	1, 7, 8
t _{PHZ} t _{PLZ}	Output Disable Time DIR or OE to Bus	1.5	9.0	1.5	6.3	ns	1, 7, 8
t _{PLH} t _{PHL}	Propagation Delay Clock to Bus	1.5	9.0	1.5	6.3	ns	1, 5
t _{PLH} t _{PHL}	Propagation Delay SBA or SAB to Bus	1.5	11.0	1.5	7.7	ns	1,5
t _{SU}	Set-Up Time HIGH or LOW Bus to Clock	2.0	—	2.0	—	ns	4
t _H	Hold Time HIGH or LOW Bus to Clock	1.5	—	1.5	—	ns	4
t _W	Clock Pulse Width HIGH or LOW	5.0	—	5.0	—	ns	6
t _{SK(O)}	Output Skew ^[17]	—	0.5	—	0.5	ns	—

Parameter	Description	CY74FCT16646CT CY74FCT162646CT		Unit	Fig. No. ^[16]
		Min.	Max.		
t _{PLH} t _{PHL}	Propagation Delay Bus to Bus	1.5	5.4	ns	1, 2
t _{PZH} t _{PZL}	Output Enable Time DIR or OE to Bus	1.5	7.8	ns	1, 7, 8
t _{PHZ} t _{PLZ}	Output Disable Time DIR or OE to Bus	1.5	6.3	ns	1, 7, 8
t _{PLH} t _{PHL}	Propagation Delay Clock to Bus	1.5	5.7	ns	1, 5
t _{PLH} t _{PHL}	Propagation Delay SBA or SAB to Bus	1.5	6.2	ns	1,5
t _{SU}	Set-Up Time HIGH or LOW Bus to Clock	2.0	—	ns	4
t _H	Hold Time HIGH or LOW Bus to Clock	1.5	—	ns	4
t _W	Clock Pulse Width HIGH or LOW	5.0	—	ns	6
t _{SK(O)}	Output Skew ^[17]	—	0.5	ns	—

Notes:

15. Minimum limits are specified but not tested on Propagation Delays.

16. See "Parameter Measurement Information" in the General Information section.

17. Skew any two outputs of the same package switching in the same direction. This parameter is ensured by design.

Ordering Information CY74FCT16646

Speed (ns)	Ordering Code	Package Name	Package Type	Operating Range
5.4	CY74FCT16646CTPVC/PVCT	O56	56-Lead (300-Mil) SSOP	Industrial
6.3	CY74FCT16646ATPVC/PVCT	O56	56-Lead (300-Mil) SSOP	Industrial
9.0	CY74FCT16646TPVC/PVCT	O56	56-Lead (300-Mil) SSOP	Industrial

Ordering Information CY74FCT162646

Speed (ns)	Ordering Code	Package Name	Package Type	Operating Range
5.4	74FCT162646CTPACT	Z56	56-Lead (240-Mil) TSSOP	Industrial
	CY74FCT162646CTPVC	O56	56-Lead (300-Mil) SSOP	
	74FCT162646CTPVCT	O56	56-Lead (300-Mil) SSOP	
6.3	74FCT162646ATPACT	Z56	56-Lead (240-Mil) TSSOP	Industrial
	CY74FCT162646ATPVC	O56	56-Lead (300-Mil) SSOP	
	74FCT162646ATPVCT	O56	56-Lead (300-Mil) SSOP	

Package Diagrams

56-Lead Shrunk Small Outline Package O56

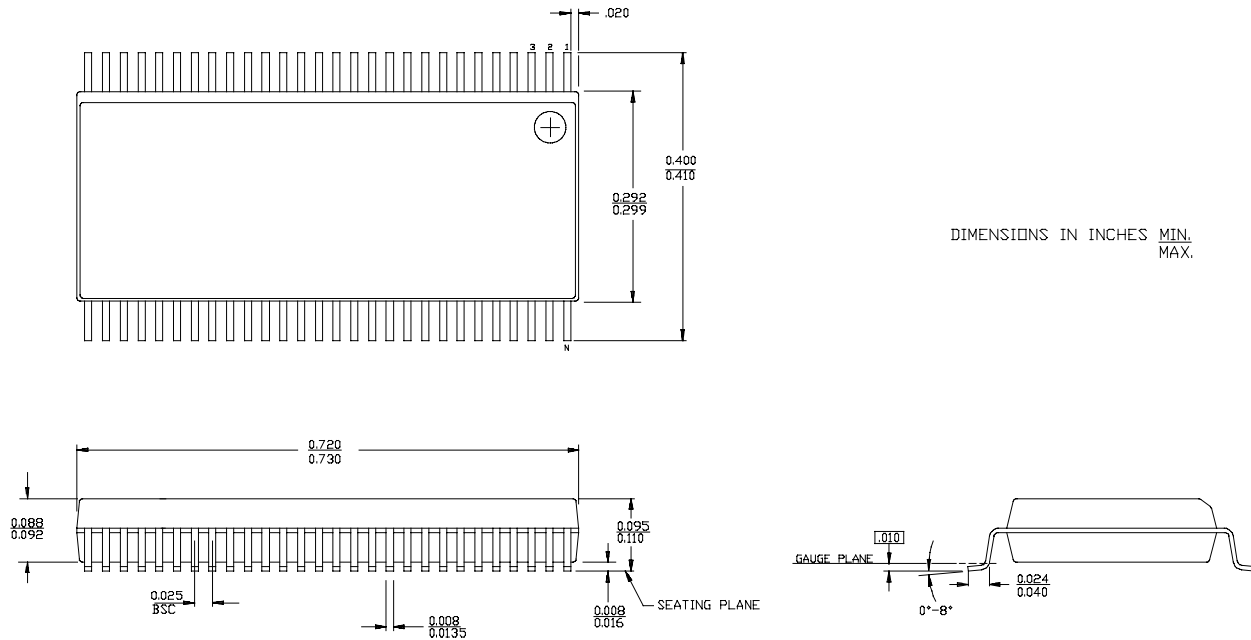

56-Lead Thin Shrunk Small Outline Package Z56

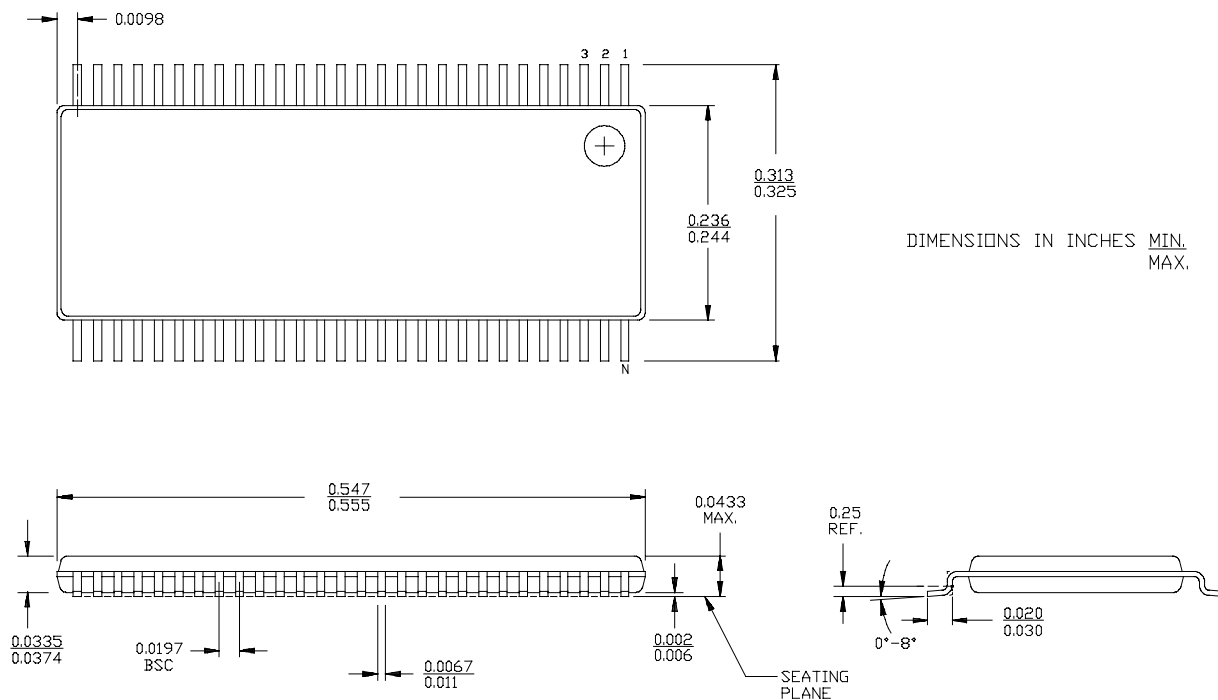

PACKAGING INFORMATION

Orderable Device	Status ⁽¹⁾	Package Type	Package Drawing	Pins	Package Qty	Eco Plan ⁽²⁾	Lead/Ball Finish	MSL Peak Temp ⁽³⁾
74FCT162646ATPACT	ACTIVE	TSSOP	DGG	56	2000	Green (RoHS & no Sb/Br)	CU NIPDAU	Level-1-260C-UNLIM
74FCT162646ATPVCG4	ACTIVE	SSOP	DL	56	20	Green (RoHS & no Sb/Br)	CU NIPDAU	Level-1-260C-UNLIM
74FCT162646ATPVCT	ACTIVE	SSOP	DL	56	1000	Green (RoHS & no Sb/Br)	CU NIPDAU	Level-1-260C-UNLIM
74FCT162646CTPACT	ACTIVE	TSSOP	DGG	56	2000	Green (RoHS & no Sb/Br)	CU NIPDAU	Level-1-260C-UNLIM
74FCT162646CTPVCG4	ACTIVE	SSOP	DL	56	20	Green (RoHS & no Sb/Br)	CU NIPDAU	Level-1-260C-UNLIM
74FCT162646CTPVCT	ACTIVE	SSOP	DL	56	1000	Green (RoHS & no Sb/Br)	CU NIPDAU	Level-1-260C-UNLIM
74FCT16646ATPVCG4	ACTIVE	SSOP	DL	56	20	Green (RoHS & no Sb/Br)	CU NIPDAU	Level-1-260C-UNLIM
74FCT16646ATPVCTG4	ACTIVE	SSOP	DL	56	1000	Green (RoHS & no Sb/Br)	CU NIPDAU	Level-1-260C-UNLIM
74FCT16646CTPVCG4	ACTIVE	SSOP	DL	56	20	Green (RoHS & no Sb/Br)	CU NIPDAU	Level-1-260C-UNLIM
74FCT16646CTPVCTG4	ACTIVE	SSOP	DL	56	1000	Green (RoHS & no Sb/Br)	CU NIPDAU	Level-1-260C-UNLIM
74FCT16646TPVCTG4	ACTIVE	SSOP	DL	56	1000	Green (RoHS & no Sb/Br)	CU NIPDAU	Level-1-260C-UNLIM
CY74FCT162646ATPVC	ACTIVE	SSOP	DL	56	20	Green (RoHS & no Sb/Br)	CU NIPDAU	Level-1-260C-UNLIM
CY74FCT162646CTPVC	ACTIVE	SSOP	DL	56	20	Green (RoHS & no Sb/Br)	CU NIPDAU	Level-1-260C-UNLIM
CY74FCT16646ATPVC	ACTIVE	SSOP	DL	56	20	Green (RoHS & no Sb/Br)	CU NIPDAU	Level-1-260C-UNLIM
CY74FCT16646ATPVCT	ACTIVE	SSOP	DL	56	1000	Green (RoHS & no Sb/Br)	CU NIPDAU	Level-1-260C-UNLIM
CY74FCT16646CTPVC	ACTIVE	SSOP	DL	56	20	Green (RoHS & no Sb/Br)	CU NIPDAU	Level-1-260C-UNLIM
CY74FCT16646CTPVCT	ACTIVE	SSOP	DL	56	1000	Green (RoHS & no Sb/Br)	CU NIPDAU	Level-1-260C-UNLIM
CY74FCT16646ETPVC	OBSOLETE	SSOP	DL	56		TBD	Call TI	Call TI
CY74FCT16646ETPVCT	OBSOLETE	SSOP	DL	56		TBD	Call TI	Call TI
CY74FCT16646TPVCT	ACTIVE	SSOP	DL	56	1000	Green (RoHS & no Sb/Br)	CU NIPDAU	Level-1-260C-UNLIM
FCT162646ATPACTE4	ACTIVE	TSSOP	DGG	56	2000	Green (RoHS & no Sb/Br)	CU NIPDAU	Level-1-260C-UNLIM
FCT162646ATPACTG4	ACTIVE	TSSOP	DGG	56	2000	Green (RoHS & no Sb/Br)	CU NIPDAU	Level-1-260C-UNLIM
FCT162646ATPVCTG4	ACTIVE	SSOP	DL	56	1000	Green (RoHS & no Sb/Br)	CU NIPDAU	Level-1-260C-UNLIM
FCT162646CTPACTE4	ACTIVE	TSSOP	DGG	56	2000	Green (RoHS & no Sb/Br)	CU NIPDAU	Level-1-260C-UNLIM
FCT162646CTPACTG4	ACTIVE	TSSOP	DGG	56	2000	Green (RoHS & no Sb/Br)	CU NIPDAU	Level-1-260C-UNLIM
FCT162646CTPVCTG4	ACTIVE	SSOP	DL	56	1000	Green (RoHS & no Sb/Br)	CU NIPDAU	Level-1-260C-UNLIM

Orderable Device	Status ⁽¹⁾	Package Type	Package Drawing	Pins	Package Qty	Eco Plan ⁽²⁾	Lead/Ball Finish	MSL Peak Temp ⁽³⁾
no Sb/Br)								

⁽¹⁾ The marketing status values are defined as follows:

ACTIVE: Product device recommended for new designs.

LIFEBUY: TI has announced that the device will be discontinued, and a lifetime-buy period is in effect.

NRND: Not recommended for new designs. Device is in production to support existing customers, but TI does not recommend using this part in a new design.

PREVIEW: Device has been announced but is not in production. Samples may or may not be available.

OBSOLETE: TI has discontinued the production of the device.

⁽²⁾ Eco Plan - The planned eco-friendly classification: Pb-Free (RoHS), Pb-Free (RoHS Exempt), or Green (RoHS & no Sb/Br) - please check <http://www.ti.com/productcontent> for the latest availability information and additional product content details.

TBD: The Pb-Free/Green conversion plan has not been defined.

Pb-Free (RoHS): TI's terms "Lead-Free" or "Pb-Free" mean semiconductor products that are compatible with the current RoHS requirements for all 6 substances, including the requirement that lead not exceed 0.1% by weight in homogeneous materials. Where designed to be soldered at high temperatures, TI Pb-Free products are suitable for use in specified lead-free processes.

Pb-Free (RoHS Exempt): This component has a RoHS exemption for either 1) lead-based flip-chip solder bumps used between the die and package, or 2) lead-based die adhesive used between the die and leadframe. The component is otherwise considered Pb-Free (RoHS compatible) as defined above.

Green (RoHS & no Sb/Br): TI defines "Green" to mean Pb-Free (RoHS compatible), and free of Bromine (Br) and Antimony (Sb) based flame retardants (Br or Sb do not exceed 0.1% by weight in homogeneous material)

⁽³⁾ MSL, Peak Temp. -- The Moisture Sensitivity Level rating according to the JEDEC industry standard classifications, and peak solder temperature.

Important Information and Disclaimer:The information provided on this page represents TI's knowledge and belief as of the date that it is provided. TI bases its knowledge and belief on information provided by third parties, and makes no representation or warranty as to the accuracy of such information. Efforts are underway to better integrate information from third parties. TI has taken and continues to take reasonable steps to provide representative and accurate information but may not have conducted destructive testing or chemical analysis on incoming materials and chemicals. TI and TI suppliers consider certain information to be proprietary, and thus CAS numbers and other limited information may not be available for release.

In no event shall TI's liability arising out of such information exceed the total purchase price of the TI part(s) at issue in this document sold by TI to Customer on an annual basis.

TAPE AND REEL INFORMATION



QUADRANT ASSIGNMENTS FOR PIN 1 ORIENTATION IN TAPE

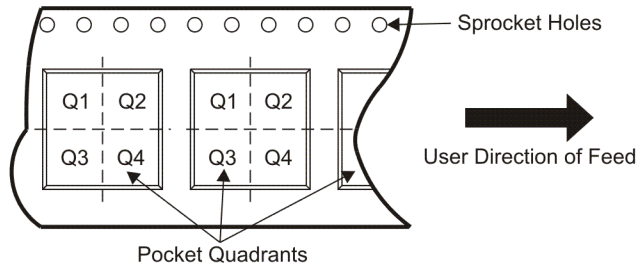

*All dimensions are nominal

Device	Package Type	Package Drawing	Pins	SPQ	Reel Diameter (mm)	Reel Width W1 (mm)	A0 (mm)	B0 (mm)	K0 (mm)	P1 (mm)	W (mm)	Pin1 Quadrant
74FCT162646ATPACT	TSSOP	DGG	56	2000	330.0	24.4	8.6	15.6	1.8	12.0	24.0	Q1
74FCT162646ATPVCT	SSOP	DL	56	1000	330.0	32.4	11.35	18.67	3.1	16.0	32.0	Q1
74FCT162646CTPACT	TSSOP	DGG	56	2000	330.0	24.4	8.6	15.6	1.8	12.0	24.0	Q1
74FCT162646CTPVCT	SSOP	DL	56	1000	330.0	32.4	11.35	18.67	3.1	16.0	32.0	Q1
CY74FCT16646ATPVCT	SSOP	DL	56	1000	330.0	32.4	11.35	18.67	3.1	16.0	32.0	Q1
CY74FCT16646CTPVCT	SSOP	DL	56	1000	330.0	32.4	11.35	18.67	3.1	16.0	32.0	Q1
CY74FCT16646TPVCT	SSOP	DL	56	1000	330.0	32.4	11.35	18.67	3.1	16.0	32.0	Q1

TAPE AND REEL BOX DIMENSIONS



*All dimensions are nominal

Device	Package Type	Package Drawing	Pins	SPQ	Length (mm)	Width (mm)	Height (mm)
74FCT162646ATPACT	TSSOP	DGG	56	2000	346.0	346.0	41.0
74FCT162646ATPVCT	SSOP	DL	56	1000	346.0	346.0	49.0
74FCT162646CTPACT	TSSOP	DGG	56	2000	346.0	346.0	41.0
74FCT162646CTPVCT	SSOP	DL	56	1000	346.0	346.0	49.0
CY74FCT16646ATPVCT	SSOP	DL	56	1000	346.0	346.0	49.0
CY74FCT16646CTPVCT	SSOP	DL	56	1000	346.0	346.0	49.0
CY74FCT16646TPVCT	SSOP	DL	56	1000	346.0	346.0	49.0

DGG (R-PDSO-G**)

PLASTIC SMALL-OUTLINE PACKAGE

48 PINS SHOWN



- NOTES: A. All linear dimensions are in millimeters.
 B. This drawing is subject to change without notice.
 C. Body dimensions do not include mold protrusion not to exceed 0,15.
 D. Falls within JEDEC MO-153

DL (R-PDSO-G**)

PLASTIC SMALL-OUTLINE PACKAGE

48 PINS SHOWN

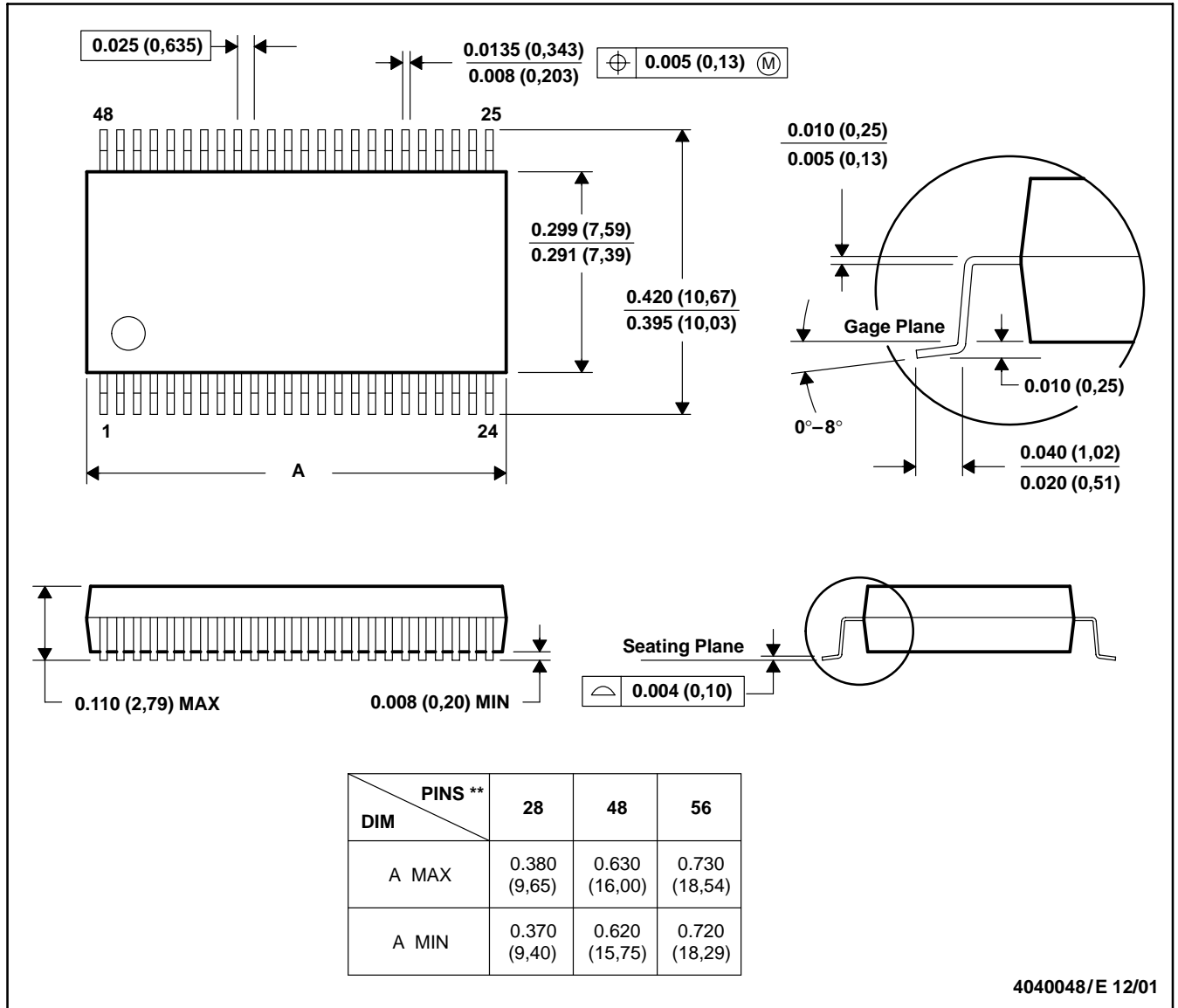

- NOTES: A. All linear dimensions are in inches (millimeters).
 B. This drawing is subject to change without notice.
 C. Body dimensions do not include mold flash or protrusion not to exceed 0.006 (0,15).
 D. Falls within JEDEC MO-118

PACKAGING INFORMATION

Orderable Device	Status (1)	Package Type	Package Drawing	Pins	Package Qty	Eco Plan (2)	Lead finish/ Ball material (6)	MSL Peak Temp (3)	Op Temp (°C)	Device Marking (4/5)	Samples
74FCT162646ATPVCG4	ACTIVE	SSOP	DL	56	20	RoHS & Green	NIPDAU	Level-1-260C-UNLIM	-40 to 85	FCT162646A	Samples
74FCT162646ATPVCT	ACTIVE	SSOP	DL	56	1000	RoHS & Green	NIPDAU	Level-1-260C-UNLIM	-40 to 85	FCT162646A	Samples
74FCT162646CTPACT	ACTIVE	TSSOP	DGG	56	2000	RoHS & Green	NIPDAU	Level-1-260C-UNLIM	-40 to 85	FCT162646C	Samples
74FCT162646CTPVCG4	ACTIVE	SSOP	DL	56	20	RoHS & Green	NIPDAU	Level-1-260C-UNLIM	-40 to 85	FCT162646C	Samples
74FCT162646CTPVCT	ACTIVE	SSOP	DL	56	1000	RoHS & Green	NIPDAU	Level-1-260C-UNLIM	-40 to 85	FCT162646C	Samples
74FCT16646ATPVCG4	ACTIVE	SSOP	DL	56	20	RoHS & Green	NIPDAU	Level-1-260C-UNLIM	-40 to 85	FCT16646A	Samples
CY74FCT162646ATPVC	ACTIVE	SSOP	DL	56	20	RoHS & Green	NIPDAU	Level-1-260C-UNLIM	-40 to 85	FCT162646A	Samples
CY74FCT162646CTPVC	ACTIVE	SSOP	DL	56	20	RoHS & Green	NIPDAU	Level-1-260C-UNLIM	-40 to 85	FCT162646C	Samples
CY74FCT16646ATPVC	ACTIVE	SSOP	DL	56	20	RoHS & Green	NIPDAU	Level-1-260C-UNLIM	-40 to 85	FCT16646A	Samples
CY74FCT16646ATPVCT	ACTIVE	SSOP	DL	56	1000	RoHS & Green	NIPDAU	Level-1-260C-UNLIM	-40 to 85	FCT16646A	Samples
CY74FCT16646CTPVC	ACTIVE	SSOP	DL	56	20	RoHS & Green	NIPDAU	Level-1-260C-UNLIM	-40 to 85	FCT16646C	Samples
CY74FCT16646CTPVCT	ACTIVE	SSOP	DL	56	1000	RoHS & Green	NIPDAU	Level-1-260C-UNLIM	-40 to 85	FCT16646C	Samples

(1) The marketing status values are defined as follows:

ACTIVE: Product device recommended for new designs.

LIFEBUY: TI has announced that the device will be discontinued, and a lifetime-buy period is in effect.

NRND: Not recommended for new designs. Device is in production to support existing customers, but TI does not recommend using this part in a new design.

PREVIEW: Device has been announced but is not in production. Samples may or may not be available.

OBSOLETE: TI has discontinued the production of the device.

(2) **RoHS:** TI defines "RoHS" to mean semiconductor products that are compliant with the current EU RoHS requirements for all 10 RoHS substances, including the requirement that RoHS substance do not exceed 0.1% by weight in homogeneous materials. Where designed to be soldered at high temperatures, "RoHS" products are suitable for use in specified lead-free processes. TI may reference these types of products as "Pb-Free".

RoHS Exempt: TI defines "RoHS Exempt" to mean products that contain lead but are compliant with EU RoHS pursuant to a specific EU RoHS exemption.

Green: TI defines "Green" to mean the content of Chlorine (Cl) and Bromine (Br) based flame retardants meet JS709B low halogen requirements of <=1000ppm threshold. Antimony trioxide based flame retardants must also meet the <=1000ppm threshold requirement.

- (3) MSL, Peak Temp. - The Moisture Sensitivity Level rating according to the JEDEC industry standard classifications, and peak solder temperature.
- (4) There may be additional marking, which relates to the logo, the lot trace code information, or the environmental category on the device.
- (5) Multiple Device Markings will be inside parentheses. Only one Device Marking contained in parentheses and separated by a "~" will appear on a device. If a line is indented then it is a continuation of the previous line and the two combined represent the entire Device Marking for that device.
- (6) Lead finish/Ball material - Orderable Devices may have multiple material finish options. Finish options are separated by a vertical ruled line. Lead finish/Ball material values may wrap to two lines if the finish value exceeds the maximum column width.

Important Information and Disclaimer:The information provided on this page represents TI's knowledge and belief as of the date that it is provided. TI bases its knowledge and belief on information provided by third parties, and makes no representation or warranty as to the accuracy of such information. Efforts are underway to better integrate information from third parties. TI has taken and continues to take reasonable steps to provide representative and accurate information but may not have conducted destructive testing or chemical analysis on incoming materials and chemicals. TI and TI suppliers consider certain information to be proprietary, and thus CAS numbers and other limited information may not be available for release.

In no event shall TI's liability arising out of such information exceed the total purchase price of the TI part(s) at issue in this document sold by TI to Customer on an annual basis.

TAPE AND REEL INFORMATION

QUADRANT ASSIGNMENTS FOR PIN 1 ORIENTATION IN TAPE



*All dimensions are nominal

Device	Package Type	Package Drawing	Pins	SPQ	Reel Diameter (mm)	Reel Width W1 (mm)	A0 (mm)	B0 (mm)	K0 (mm)	P1 (mm)	W (mm)	Pin1 Quadrant
74FCT162646ATPVCT	SSOP	DL	56	1000	330.0	32.4	11.35	18.67	3.1	16.0	32.0	Q1
74FCT162646CTPACT	TSSOP	DGG	56	2000	330.0	24.4	8.6	15.6	1.8	12.0	24.0	Q1
74FCT162646CTPVCT	SSOP	DL	56	1000	330.0	32.4	11.35	18.67	3.1	16.0	32.0	Q1
CY74FCT16646ATPVCT	SSOP	DL	56	1000	330.0	32.4	11.35	18.67	3.1	16.0	32.0	Q1
CY74FCT16646CTPVCT	SSOP	DL	56	1000	330.0	32.4	11.35	18.67	3.1	16.0	32.0	Q1

TAPE AND REEL BOX DIMENSIONS

*All dimensions are nominal

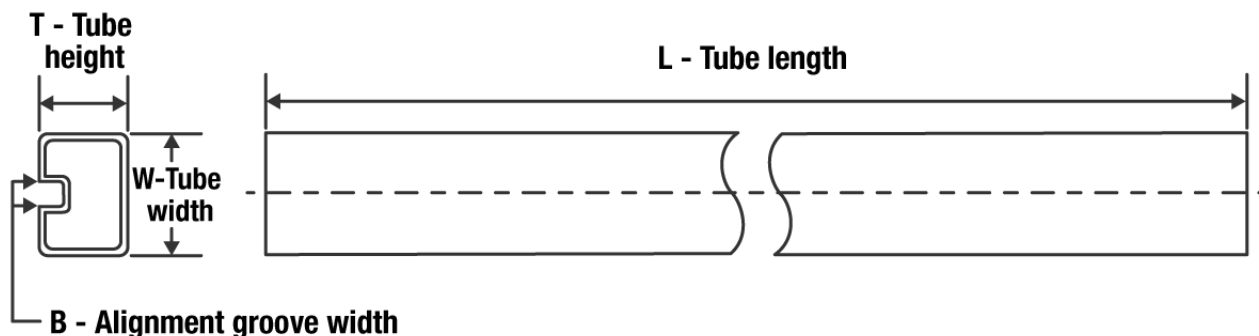
Device	Package Type	Package Drawing	Pins	SPQ	Length (mm)	Width (mm)	Height (mm)
74FCT162646ATPVCT	SSOP	DL	56	1000	367.0	367.0	55.0
74FCT162646CTPACT	TSSOP	DGG	56	2000	367.0	367.0	45.0
74FCT162646CTPVCT	SSOP	DL	56	1000	367.0	367.0	55.0
CY74FCT16646ATPVCT	SSOP	DL	56	1000	367.0	367.0	55.0
CY74FCT16646CTPVCT	SSOP	DL	56	1000	367.0	367.0	55.0

TUBE

*All dimensions are nominal

Device	Package Name	Package Type	Pins	SPQ	L (mm)	W (mm)	T (μm)	B (mm)
74FCT162646ATPVCG4	DL	SSOP	56	20	473.7	14.24	5110	7.87
74FCT162646CTPVCG4	DL	SSOP	56	20	473.7	14.24	5110	7.87
74FCT16646ATPVCG4	DL	SSOP	56	20	473.7	14.24	5110	7.87
CY74FCT162646ATPVC	DL	SSOP	56	20	473.7	14.24	5110	7.87
CY74FCT162646CTPVC	DL	SSOP	56	20	473.7	14.24	5110	7.87
CY74FCT16646ATPVC	DL	SSOP	56	20	473.7	14.24	5110	7.87
CY74FCT16646CTPVC	DL	SSOP	56	20	473.7	14.24	5110	7.87

MECHANICAL DATA

DL (R-PDSO-G56)

PLASTIC SMALL-OUTLINE PACKAGE

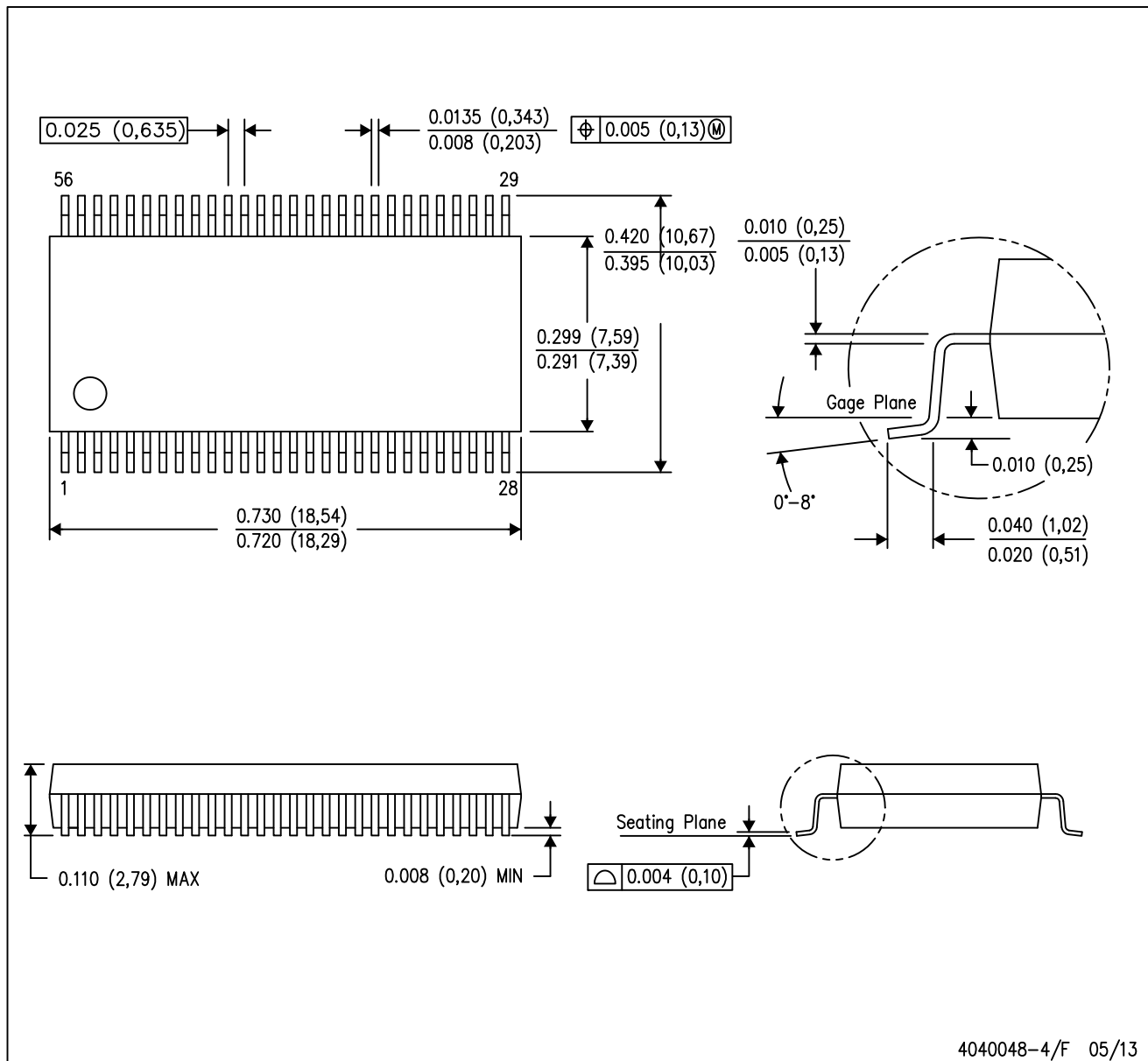

- NOTES:
- A. All linear dimensions are in inches (millimeters).
 - B. This drawing is subject to change without notice.
 - C. Body dimensions do not include mold flash or protrusion not to exceed 0.006 (0,15).
 - D. Falls within JEDEC MO-118

PowerPAD is a trademark of Texas Instruments.

DGG0056A



PACKAGE OUTLINE

TSSOP - 1.2 mm max height

SMALL OUTLINE PACKAGE

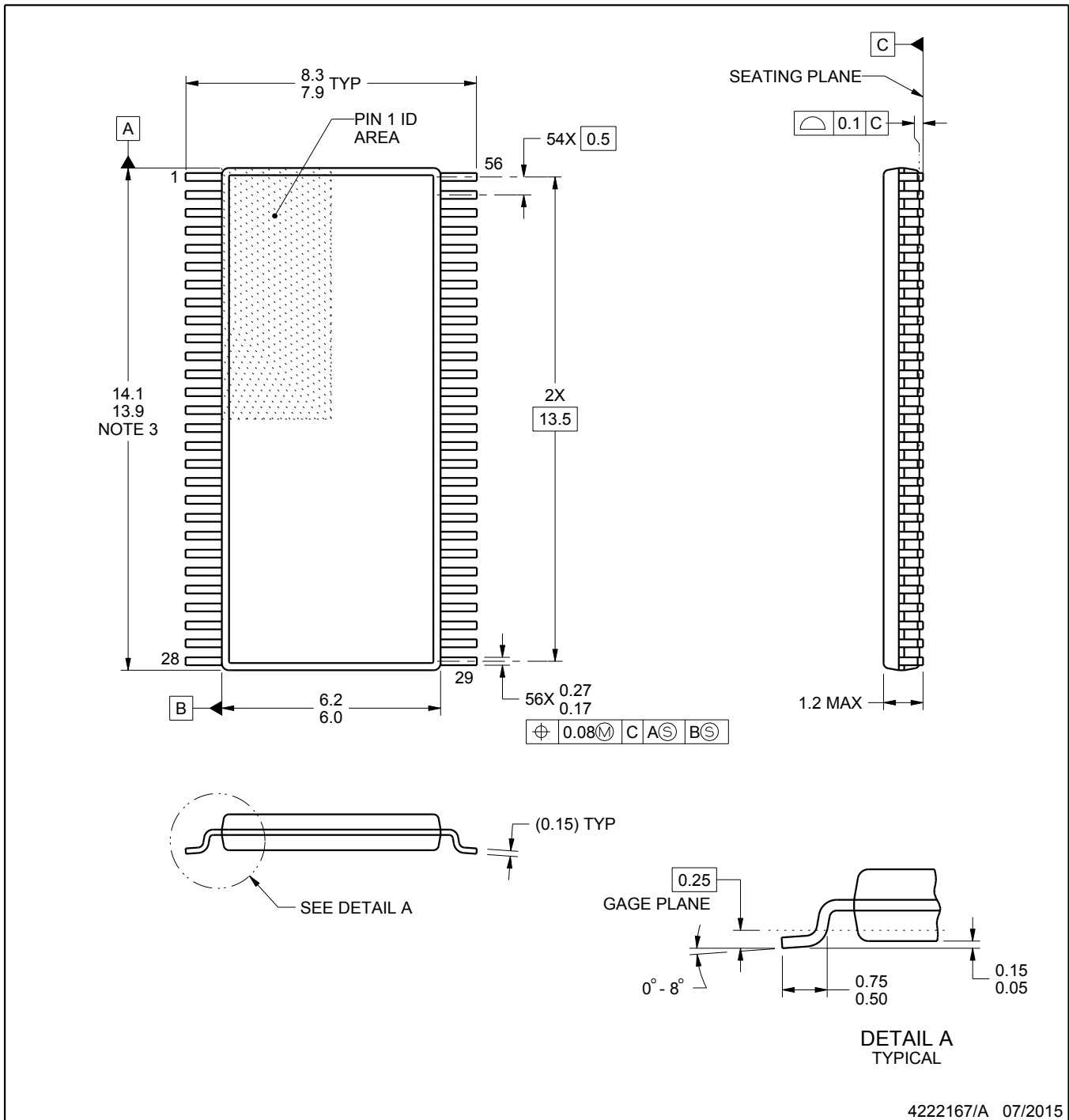

4222167/A 07/2015

NOTES:

- All linear dimensions are in millimeters. Any dimensions in parenthesis are for reference only. Dimensioning and tolerancing per ASME Y14.5M.
- This drawing is subject to change without notice.
- This dimension does not include mold flash, protrusions, or gate burrs. Mold flash, protrusions, or gate burrs shall not exceed 0.15 mm per side.
- Reference JEDEC registration MO-153.

EXAMPLE BOARD LAYOUT

DGG0056A

TSSOP - 1.2 mm max height

SMALL OUTLINE PACKAGE

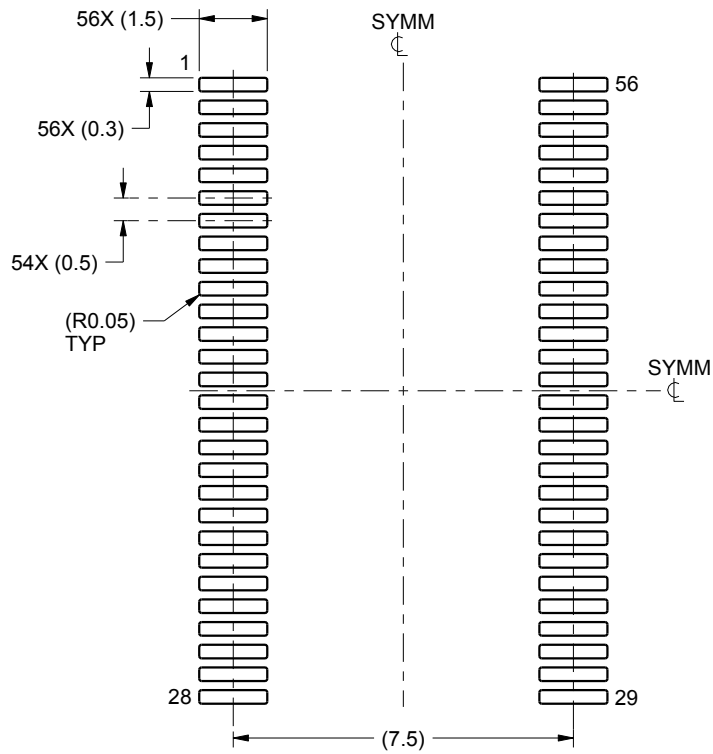

LAND PATTERN EXAMPLE
SCALE:6X

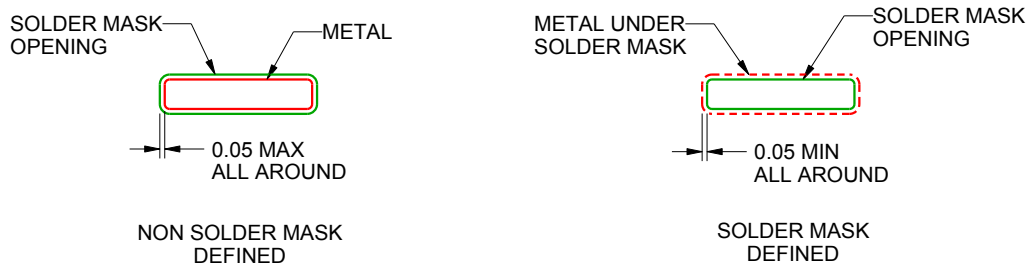

SOLDER MASK DETAILS

4222167/A 07/2015

NOTES: (continued)

- 5. Publication IPC-7351 may have alternate designs.
- 6. Solder mask tolerances between and around signal pads can vary based on board fabrication site.

EXAMPLE STENCIL DESIGN

DGG0056A

TSSOP - 1.2 mm max height

SMALL OUTLINE PACKAGE

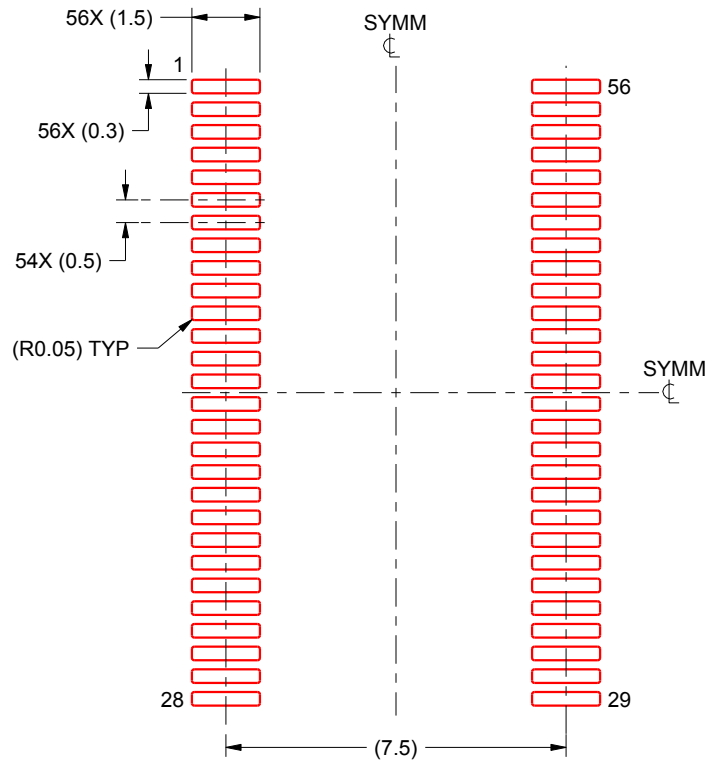

SOLDER PASTE EXAMPLE
BASED ON 0.125 mm THICK STENCIL
SCALE:6X

4222167/A 07/2015

NOTES: (continued)

7. Laser cutting apertures with trapezoidal walls and rounded corners may offer better paste release. IPC-7525 may have alternate design recommendations.
8. Board assembly site may have different recommendations for stencil design.

IMPORTANT NOTICE AND DISCLAIMER

TI PROVIDES TECHNICAL AND RELIABILITY DATA (INCLUDING DATA SHEETS), DESIGN RESOURCES (INCLUDING REFERENCE DESIGNS), APPLICATION OR OTHER DESIGN ADVICE, WEB TOOLS, SAFETY INFORMATION, AND OTHER RESOURCES "AS IS" AND WITH ALL FAULTS, AND DISCLAIMS ALL WARRANTIES, EXPRESS AND IMPLIED, INCLUDING WITHOUT LIMITATION ANY IMPLIED WARRANTIES OF MERCHANTABILITY, FITNESS FOR A PARTICULAR PURPOSE OR NON-INFRINGEMENT OF THIRD PARTY INTELLECTUAL PROPERTY RIGHTS.

These resources are intended for skilled developers designing with TI products. You are solely responsible for (1) selecting the appropriate TI products for your application, (2) designing, validating and testing your application, and (3) ensuring your application meets applicable standards, and any other safety, security, regulatory or other requirements.

These resources are subject to change without notice. TI grants you permission to use these resources only for development of an application that uses the TI products described in the resource. Other reproduction and display of these resources is prohibited. No license is granted to any other TI intellectual property right or to any third party intellectual property right. TI disclaims responsibility for, and you will fully indemnify TI and its representatives against, any claims, damages, costs, losses, and liabilities arising out of your use of these resources.

TI's products are provided subject to [TI's Terms of Sale](#) or other applicable terms available either on [ti.com](#) or provided in conjunction with such TI products. TI's provision of these resources does not expand or otherwise alter TI's applicable warranties or warranty disclaimers for TI products.

TI objects to and rejects any additional or different terms you may have proposed.

Mailing Address: Texas Instruments, Post Office Box 655303, Dallas, Texas 75265
Copyright © 2022, Texas Instruments Incorporated