

DS160PR410 四通道 PCI-Express 第 4 代线性转接驱动器

1 特性

- 四通道线性均衡器，可支持第 1/2/3/4 代 PCIe 传输速率高达 16Gbps 的接口
- 提供均衡功能，以处理高达 45dB 的 PCIe 通道
- 8GHz 下高达 18dB 的 CTLE 升压有助于扩展通道长度
- 针对 PCIe 用例的自动接收器检测
- 与协议无关的线性转接驱动器可无缝支持 PCIe 链接训练
- 支持高达 25Gbps 的数据速率，包括超级路径互联 (UPI)
- 100ps 的超低延迟
- 160fs 的低附加随机抖动
- 3.3V 单电源
- 130mW/通道的低有功率支持在无散热器的情况下运行
- 引脚搭接、SMBus 或 EEPROM 编程
- 通过一个或多个 DS160PR410 支持 x2、x4、x8、x16 PCIe 总线宽度
- -40°C 至 85°C 的工业温度范围
- 4mm × 6mm 40 引脚 WQFN 封装

2 应用

- 机架式服务器
- 高性能计算
- 微服务器和塔式服务器
- 网络附加存储、存储附加网络
- 硬件加速器
- 主机总线适配器、网络接口卡
- 台式计算机/主板

3 说明

DS160PR410 器件是一款低功耗高性能线性中继器/转接驱动器，专为支持第 1、2、3 和 4 代 PCIe 而设计。接收器的连续时间线性均衡器 (CTLE) 提供可编程高频增强功能，后接一个线性输出驱动器。CTLE 接收器能够打开一个因码间串扰 (ISI) (由 PC 电路板引线或铜质同轴电缆等互连介质引起) 而完全关闭的输入眼型状态。可编程的均衡能够在互连通道内的实体布局方面实现最大限度的灵活性并提高通道的总体性能。

DS160PR410 保留了发射预设信号的特性，因此允许主机控制器和终点协商发射均衡器系数。这种链路协商协议的透明管理有助于实现系统级互操作性并最大程度地减小延迟。

可通过软件 (SMBus 或 I2C)、直接从外部 EEPROM 加载或使用引脚控制来轻松应用可编程设置。在 EEPROM 模式下，配置信息在加电时自动加载，这样就免除了对于外部微控制器或软件驱动程序的需要。

器件信息⁽¹⁾

器件型号	封装	封装尺寸 (标称值)
DS160PR410	WQFN (40)	4.00mm × 6.00mm

(1) 如需了解所有可用封装，请参阅数据表末尾的可订购产品附录。

典型应用

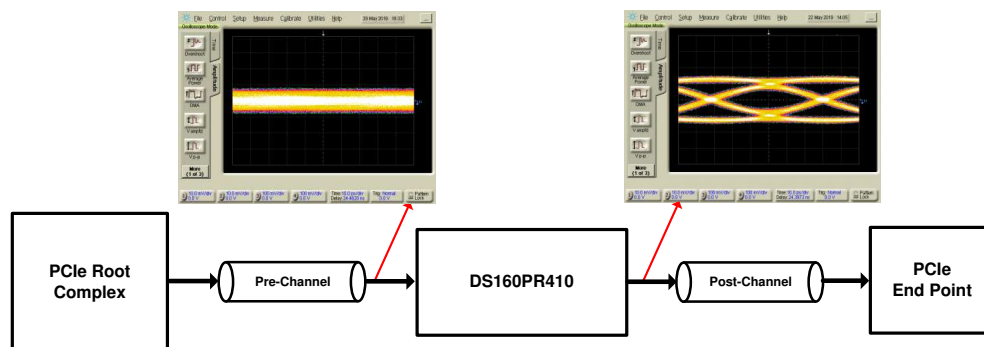

目录

1	特性	1	7.4	Device Functional Modes	12
2	应用	1	7.5	Programming	12
3	说明	1	8	Application and Implementation	15
4	修订历史记录	2	8.1	Application Information	15
5	Pin Configuration and Functions	3	8.2	Typical Applications	15
6	Specifications	5	9	Power Supply Recommendations	22
6.1	Absolute Maximum Ratings	5	10	Layout	22
6.2	ESD Ratings	5	10.1	Layout Guidelines	22
6.3	Recommended Operating Conditions	5	10.2	Layout Example	23
6.4	Thermal Information	6	11	器件和文档支持	24
6.5	DC Electrical Characteristics	6	11.1	文档支持	24
6.6	High Speed Electrical Characteristics	7	11.2	接收文档更新通知	24
6.7	SMBUS/I2C Timing Characteristics	8	11.3	社区资源	24
7	Detailed Description	10	11.4	商标	24
7.1	Overview	10	11.5	静电放电警告	24
7.2	Functional Block Diagram	10	11.6	Glossary	24
7.3	Feature Description	10	12	机械、封装和可订购信息	24

4 修订历史记录

注：之前版本的页码可能与当前版本有所不同。

日期	修订版本	说明
8月2019年	*	初始发行版。

5 Pin Configuration and Functions

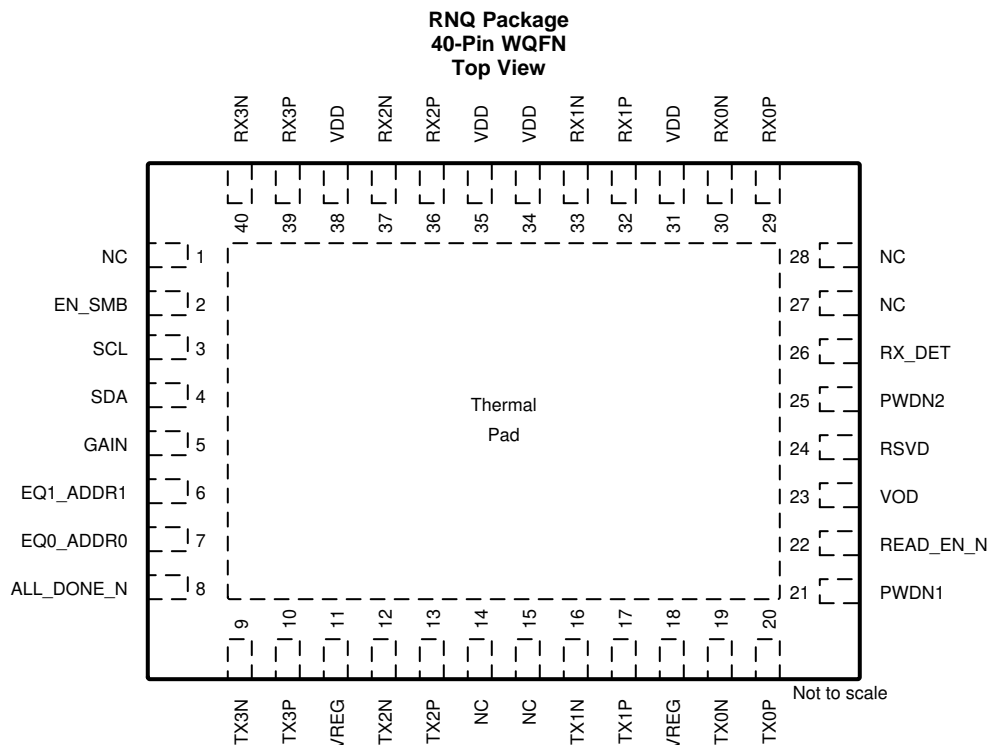

Pin Functions

PIN		I/O, TYPE	DESCRIPTION
NAME	NO.		
ALL_DONE_N	8	O, 3.3-V open drain	Indicates the completion of a valid EEPROM register load operation when in SMBus/I2C Master Mode (EN_SMB = L1): High: External EEPROM load failed or incomplete Low: External EEPROM load successful and complete When in SMBus/I2C slave mode (EN_SMB = L3), this output will be High-Z until READ_EN_N is driven low, at which point ALL_DONE_N will be driven low. External pullup required for operation. TI recommends a 4.7k value.
EN_SMB	2	I, 4-level	Four-level control input used to select SMBus / I2C or Pin control. The four defined levels are: L0: Pin mode L1: I2C or SMBus Master Mode L2: RESERVED L3: I2C or SMBus Slave Mode
EQ0_ADDR0	7	I, 4-level	The 4-Level Control Input pins of DS160PR410 is defined according to 表 3. If EN_SMB = L1 or L3, the pins are used to set the I2C or SMBus address of the device. The pin state is read on power up and decoded according to 表 4. If EN_SMB = L0, the pins are decoded at power up to control the CTLE boost setting according to 表 1.
EQ1_ADDR1	6	I, 4-level	
GAIN	5	I, 4-level	Sets DC gain of CTLE at power up. L0: Reserved L1: Reserved L2: 0 dB L3: 3.5 dB
GND	EP	P	EP is the Exposed Pad at the bottom of the WQFN package. It is used as the GND return for the device. The EP should be connected to ground plane(s) through low resistance path. A via array provides a low impedance path to GND, and also improves thermal dissipation.
NC	1, 14, 15, 27, 28	—	No connect

ADVANCE INFORMATION

Pin Functions (continued)

PIN		I/O, TYPE	DESCRIPTION
NAME	NO.		
PWDN1	21	I, 3.3-V LVCMOS	Two-level logic controlling the operating state of the redriver. High: Power down for channels 0 and 1 Low: Power up, normal operation for channels 0 and 1.
PWDN2	25	I, 3.3-V LVCMOS	Two-level logic controlling the operating state of the redriver. High: Power down for channels 2 and 3 Low: Power up, normal operation for channels 2 and 3.
READ_EN_N	22	I, 3.3-V LVCMOS	SMBus / I2C Master Mode (with EN_SMB = L1): When asserted low, initiates the SMBus / I2C master mode EEPROM read function. When the EEPROM read is complete (indicated by assertion of ALL_DONE_N low), this pin can be held low for normal device operation. SMBus / I2C Slave Mode (with EN_SMB = L3): When asserted low, this causes the device to be held in reset (I2C state machine reset and register reset). This pin should be pulled high to 3.3 V with a external 4.7-kΩ pullup for normal operation in SMBus / I2C Slave Mode or in pin control mode.
RSVD	24	—	Reserved use for TI. The pin must be left floating (NC).
RX_DET	26	I, 4-level	The RX_DET pin controls the receiver detect function. Depending on the input level, a 50-Ω or >50-kΩ termination to the power rail is enabled. See 表 2 for details.
RX0N	30	I	Inverting differential inputs to the equalizer. An on-chip, 100-Ω termination resistor connects RXP to RXN. Channel 0.
RX0P	29	I	Noninverting differential inputs to the equalizer. An on-chip, 100-Ω termination resistor connects RXP to RXN. Channel 0.
RX1N	33	I	Inverting differential inputs to the equalizer. An on-chip, 100-Ω termination resistor connects RXP to RXN. Channel 1.
RX1P	32	I	Noninverting differential inputs to the equalizer. An on-chip, 100-Ω termination resistor connects RXP to RXN. Channel 1.
RX2N	37	I	Inverting differential inputs to the equalizer. An on-chip, 100-Ω termination resistor connects RXP to RXN. Channel 2.
RX2P	36	I	Noninverting differential inputs to the equalizer. An on-chip, 100-Ω termination resistor connects RXP to RXN. Channel 2.
RX3N	40	I	Inverting differential inputs to the equalizer. An on-chip, 100-Ω termination resistor connects RXP to RXN. Channel 3.
RX3P	39	I	Noninverting differential inputs to the equalizer. An on-chip, 100-Ω termination resistor connects RXP to RXN. Channel 3.
SCL	3	I/O, 3.3-V LVCMOS, open drain	SMBus / I2C clock input / open-drain output. External 1-kΩ to 5-kΩ pullup resistor is required as per SMBus / I2C interface standard. This pin is 3.3-V tolerant.
SDA	4	I/O, 3.3-V LVCMOS, open drain	SMBus / I2C data input / open-drain clock output. External 1-kΩ to 5-kΩ pullup resistor is required as per SMBus interface standard. This pin is 3.3-V tolerant.
TX0N	19	O	Inverting 50-Ω driver outputs. Compatible with AC-coupled differential inputs. Also used for RX detection at power up. Channel 0.
TX0P	20	O	Noninverting 50-Ω driver outputs. Compatible with AC-coupled differential inputs. Also used for RX detection at power up. Channel 0.
TX1N	16	O	Inverting 50-Ω driver outputs. Compatible with AC-coupled differential inputs. Also used for RX detection at power up. Channel 1.
TX1P	17	O	Noninverting 50-Ω driver outputs. Compatible with AC-coupled differential inputs. Also used for RX detection at power up. Channel 1.
TX2N	12	O	Inverting 50-Ω driver outputs. Compatible with AC-coupled differential inputs. Also used for RX detection at power up. Channel 2.
TX2P	13	O	Noninverting 50-Ω driver outputs. Compatible with AC-coupled differential inputs. Also used for RX detection at power up. Channel 2.
TX3N	9	O	Inverting 50-Ω driver outputs. Compatible with AC-coupled differential inputs. Also used for RX detection at power up. Channel 3.
TX3P	10	O	Noninverting 50-Ω driver outputs. Compatible with AC-coupled differential inputs. Also used for RX detection at power up. Channel 3.
VDD	31, 34, 35, 38	P	Power supply pins. $V_{DD} = 3.3\text{ V} \pm 10\%$. The VDD pins on this device should be connected through a low-resistance path to the board VDD plane.

Pin Functions (continued)

PIN		I/O, TYPE	DESCRIPTION
NAME	NO.		
VOD	23	I, 4-level	Sets TX VOD setting at power up. L0: –6 dB L1: –3.5 dB L2: 0 dB L3: –1.6 dB
VREG	11, 18	P	Internal voltage regulator output. Must add decoupling caps of 0.1 μ F near each pins. The regulator is only for internal use. Do not use to power any external components.

6 Specifications

6.1 Absolute Maximum Ratings

over operating free-air temperature range (unless otherwise noted)⁽¹⁾

		MIN	MAX	UNIT
VDD _{ABSMAX}	Supply Voltage (VDD)	–0.5	4.0	V
VIO _{CMOS,ABSMAX}	3.3 V LVCMOS and Open Drain I/O voltage	–0.5	4.0	V
VIO _{4LVL,ABSMAX}	4-level Input I/O voltage	–0.5	2.75	V
VIO _{HS,ABSMAX}	High-speed I/O voltage (RXnP, RXnN, TXnP, TXnN)	–0.5	2.75	V
T _{J,ABSMAX}	Junction temperature		150	°C
T _{stg}	Storage temperature range	–65	150	°C

- (1) Stresses beyond those listed under Absolute Maximum Ratings may cause permanent damage to the device. These are stress ratings only, which do not imply functional operation of the device at these or any other conditions beyond those indicated under Recommended Operating Conditions. Exposure to absolute-maximum-rated conditions for extended periods may affect device reliability.

6.2 ESD Ratings

			VALUE	UNIT
V _(ESD)	Electrostatic discharge	Human body model (HBM), per ANSI/ESDA/JEDEC JS-001 ⁽¹⁾	±2000	V
		Charged device model (CDM), per JEDEC specification JESD22-C101 ⁽²⁾	±500	

- (1) JEDEC document JEP155 states that 500-V HBM allows safe manufacturing with a standard ESD control process. Pins listed as ± 2 kV may actually have higher performance.
(2) JEDEC document JEP157 states that 250-V CDM allows safe manufacturing with a standard ESD control process.

6.3 Recommended Operating Conditions

over operating free-air temperature range (unless otherwise noted)

			MIN	NOM	MAX	UNIT
VDD	Supply voltage, VDD to GND	DC plus AC power should not exceed these limits	3.0	3.3	3.6	V
N _{VDD}	Supply noise tolerance	Supply noise, DC to <50 Hz, sinusoidal ¹			250	mVpp
		Supply noise, 50 Hz to 10 MHz, sinusoidal ¹			20	mVpp
		Supply noise, >10 MHz, sinusoidal ¹			10	mVpp
T _{RampVDD}	VDD supply ramp time	From 0 V to 3.0 V	0.150		100	ms
T _J	Operating junction temperature		–40		125	C
T _A	Operating ambient temperature		–40		85	C
PW _{LVC MOS}	Minimum pulse width required for the device to detect a valid signal on LVC MOS inputs	PWDN1/2, READ_EN_N	100			μ S
VDD _{SMBUS}	SMBus SDA and SCL Open Drain Termination Voltage	Supply voltage for open drain pull-up resistor			3.6	V
F _{SMBus}	SMBus clock (SCL) frequency in SMBus slave mode		10		400	kHz

Recommended Operating Conditions (continued)

over operating free-air temperature range (unless otherwise noted)

		MIN	NOM	MAX	UNIT
VID _{LAUNCH}	Source differential launch amplitude	800		1200	mVpp
DR	Data rate	1		25	Gbps

6.4 Thermal Information

THERMAL METRIC ⁽¹⁾		DS160PR410	UNIT
		RNQ, 40 Pins	
R _{θJA} -High K	Junction-to-ambient thermal resistance	31.1	°C/W
R _{θJC} (top)	Junction-to-case (top) thermal resistance	21.4	°C/W
R _{θJB}	Junction-to-board thermal resistance	12.1	°C/W
ψ _{JT}	Junction-to-top characterization parameter	0.3	°C/W
ψ _{JB}	Junction-to-board characterization parameter	12.1	°C/W
R _{θJC} (bot)	Junction-to-case (bottom) thermal resistance	4.1	°C/W

 (1) For more information about traditional and new thermal metrics, see the [IC Package Thermal Metrics application report](#).

6.5 DC Electrical Characteristics

over operating free-air temperature and voltage range (unless otherwise noted)

PARAMETER		TEST CONDITIONS	MIN	TYP	MAX	UNIT
Power						
I _{ACTIVE}	Device current consumption when all four channels are active	All four channels enabled with VOD = L2		150	200	mA
I _{ACTIVE-HALF}	Device current consumption when two channels are active	Two channels enabled with VOD = L2, PWDN1 or PWDN2=L		85	110	mA
I _{STBY}	Device current consumption in standby power mode	All four channels disabled (PWDN1,2 = H)		26	33	mA
V _{REG}	Internal regulator output			2.5		V
Control IO						
V _{IH}	High level input voltage	SDA, SCL, PWDN1, PWDN2, READ_EN_N pins	2.1			V
V _{IL}	Low level input voltage	SDA, SCL, PWDN1, PWDN2, READ_EN_N pins			1.08	V
V _{OH}	High level output voltage	R _{pull-up} = 100K (SDA, SCL, ALL_DONE_N pins)	2			V
V _{OL}	Low level output voltage	I _{OL} = -4 mA (SDA, SCL, ALL_DONE_N pins)			0.4	V
I _{IH}	Input high leakage current	V _{input} = VDD, (SCL, SDA, PWDN1, PWDN2, READ_EN_N pins)			10	μA
I _{IL}	Input low leakage current	V _{input} = 0 V, (SCL, SDA, PWDN1, PWDN2, READ_EN_N pins)	-10			μA
C _{IN-CTRL}	Input capacitance			1.5		pF
4 Level IOs (EQ0_ADDR0, EQ1_ADDR1, EN_SMB, RX_DET, VOD, GAIN pins)						
I _{IH_4L}	Input high leakage current, 4 level IOs	VIN=2.5V			10	μA
I _{IL_4L}	Input low leakage current, , 4 level IOs	VIN=GND	-150			μA
Receiver						
Z _{RX-DC}	Rx DC Single-Ended Impedance			50		Ω
Z _{RX-DIFF-DC}	Rx DC Differential Impedance			100		Ω
Transmitter						
Z _{TX-DIFF-DC}	DC Differential Tx Impedance	Impedance of Tx during active signaling, VID,diff=1Vpp		100		Ω

DC Electrical Characteristics (continued)

over operating free-air temperature and voltage range (unless otherwise noted)

PARAMETER		TEST CONDITIONS	MIN	TYP	MAX	UNIT
$I_{TX-SHORT}$	Tx Short Circuit Current	Total current the Tx can supply when shorted to GND			90	mA

6.6 High Speed Electrical Characteristics

over operating free-air temperature and voltage range (unless otherwise noted)

PARAMETER		TEST CONDITIONS	MIN	TYP	MAX	UNIT
Receiver						
X_{TRX}	Receive-side pair-to-pair isolation	Minimum pair-to-pair isolation (SDD21) between two adjacent receiver pairs from 10 MHz to 8 GHz.		-45		dB
Transmitter						
$V_{TX-AC-CM-PP}$	Tx AC Peak-to-Peak Common Mode Voltage	Measured with lowest EQ, VOD = L2; PRBS-7, 16 Gbps, over at least 10^6 bits using a bandpass-Pass Filter from 30KHz-500Mhz			50	mVpp
$V_{TX-CM-DC-ACTIVE-IDLE-DELTA}$	Absolute Delta of DC Common Mode Voltage during L0 and Electrical Idle	$V_{TX-CM-DC} = V_{OUTn+} + V_{OUTn-} /2$, Measured by taking the absolute difference of $V_{TX-CM-DC}$ during PCIe state L0 and Electrical Idle	0		100	mV
$V_{TX-CM-DC-LINE-DELTA}$	Absolute Delta of DC Common Mode Voltage between V_{OUTn+} and V_{OUTn-} during L0	Measured by taking the absolute difference of V_{OUTn+} and V_{OUTn-} during PCIe state L0	0		10	mV
$V_{TX-IDLE-DIFF-AC-p}$	AC Electrical Idle Differential Output Voltage	Measured by taking the absolute difference of V_{OUTn+} and V_{OUTn-} during Electrical Idle, Measured with a band-pass filter consisting of two first-order filters. The High-Pass and Low-Pass -3-dB bandwidths are 10 kHz and 1.25 GHz, respectively - zero at input	0		10	mV
$V_{TX-IDLE-DIFF-DC}$	DC Electrical Idle Differential Output Voltage	Measured by taking the absolute difference of V_{OUTn+} and V_{OUTn-} during Electrical Idle, Measured with a first-order Low-Pass Filter with -3-dB bandwidth of 10 kHz	0		5	mV
$V_{TX-RCV-DETECT}$	Amount of Voltage change allowed during Receiver Detection	Measured while Tx is sensing whether a low-impedance Receiver is present. No load is connected to the driver output	0		600	mV
X_{TTX}	Transmit-side pair-to-pair isolation	Minimum pair-to-pair isolation (SDD21) between two adjacent transmitter pairs from 10 MHz to 8 GHz.		-45		dB
Device Datapath						
$T_{PLHD/PHLD}$	Input-to-output latency (propagation delay) through a channel	Measured by observing propagation delay during either Low-to-High or High-to-Low transition		100	130	ps
$L_{TX-SKEW}$	Lane-to-Lane Output Skew	Measured between any two lanes within a single transmitter		14	20	ps
$T_{TX-DJ-ADD}$	Added Deterministic Jitter	Difference between measurement through redriver and baseline setup with 16Gbps PRBS15 with minimum input and output channels with minimum EQ setting.		2.5	5	ps

High Speed Electrical Characteristics (continued)

over operating free-air temperature and voltage range (unless otherwise noted)

PARAMETER		TEST CONDITIONS	MIN	TYP	MAX	UNIT
$T_{TX-RJ-ADD}$	Additive Random Jitter	Difference between measurement through redriver and baseline setup with 16Gbps PRBS15 with minimum input and output channels with minimum EQ setting.		160	200	fs RMS
$DCGAIN_{VAR,max}$	Maximum DC gain variation	VOD=L2, GAIN=L2, min EQ setting	-1.5		1.5	dB
$ACGAIN_{VAR,max}$	Maximum EQ boost variation	VOD=L2, GAIN=L2, max EQ setting, at 8Ghz	-3.0		3.0	dB
$LINEARITY_{DC}$	Input amplitude linear range. The maximum VID for which the repeater remains linear, defined as ≤ 1 dB compression of V_{out}/V_{in} .	Measured with the highest wide-band gain setting (VOD = L2,). Measured with minimal input channel and minimum EQ using 128T pattern at 2.5 Gbps.		800		mVpp
$LINEARITY_{AC}$	Input amplitude linear range. The maximum VID for which the repeater remains linear, defined as ≤ 1 dB compression of V_{out}/V_{in} .	Measured with the highest wide-band gain setting (VOD = L2,). Measured with minimal input channel and minimum EQ using 1T pattern at 16 Gbps		750		mVpp
$JITTER_{INTRIN SIC-RJ}$	Redriver intrinsic additive Random Jitter (RMS)	Difference between measurement through redriver and baseline setup with 8Ghz clock signals, lowest EQ		160	190	fs
$JITTER_{INTRIN SIC-DJ}$	Redriver intrinsic additive Deterministic Jitter	Difference between measurement through redriver and baseline setup with 8Ghz clock signals, lowest EQ		0.4	1.2	ps
$JITTER_{INTRIN SIC-TOTAL}$	Redriver intrinsic additive Total Jitter	Difference between measurement through redriver and baseline setup with 8Ghz clock signals, lowest EQ		2.5	3.5	ps

6.7 SMBUS/I2C Timing Characteristics

over operating free-air temperature range (unless otherwise noted)

PARAMETER		TEST CONDITIONS	MIN	TYP	MAX	UNIT
Slave Mode						
T_{SDA-HD}	Data hold time			0.75		ns
T_{SDA-SU}	Data setup time			100		ns
T_{SDA-R}	SDA rise time, read operation	Pull-up resistor = 1 k Ω , Cb = 50pF		150		ns
T_{SDA-F}	SDA fall time, read operation	Pull-up resistor = 1 k Ω , Cb = 50pF		4.5		ns
Master Mode						
f_{SCL}	SCL clock frequency	EN_SMB = L3 (Master Mode)	260	303	346	kHz
$T_{SCL-LOW}$	SCL low period		1.66	1.90	2.21	μ s
$T_{SCL-HIGH}$	SCL high period		1.22	1.40	1.63	μ s
$T_{HD-START}$	Hold time start operation			0.6		μ s
$T_{SU-START}$	Setup time start operation			0.6		μ s
T_{SDA-HD}	Data hold time			0.9		μ s
T_{SDA-SU}	Data setup time			0.1		μ s
$T_{SU-STOP}$	Stop condition setup time			0.6		μ s
T_{BUF}	Bus free time between Stop-Start			1.3		μ s
T_{SDC-R}	SCL rise time	Pull-up resistor = 1 k Ω		300		ns
T_{SDC-F}	SCL fall time	Pull-up resistor = 1 k Ω		300		ns
EEPROM Timing						

SMBUS/I2C Timing Characteristics (continued)

over operating free-air temperature range (unless otherwise noted)

PARAMETER		TEST CONDITIONS	MIN	TYP	MAX	UNIT
T _{EEPROM}	EEPROM configuration load time	Time to assert ALL_DONE_N after READ_EN_N has been asserted. Single device reading its configuration from an EEPROM with common channel configuration. This time scales with the number of devices reading from the same EEPROM. Does not include power-on reset time.		4		ms
T _{EEPROM}	EEPROM configuration load time	Time to assert ALL_DONE_N after READ_EN_N has been asserted. Single device reading its configuration from an EEPROM. Non-common channel configuration. This time scales with the number of devices reading from the same EEPROM. Does not include power-on reset time.		7		ms
T _{POR}	Power-on reset assertion time	Internal power-on reset (PoR) stretch between stable power supply and de-assertion of internal PoR. The SMBus address is latched on the completion of the PoR stretch, and SMBus accesses are permitted once PoR completes.		30		ms

7 Detailed Description

7.1 Overview

The DS160PR410 is a four-channel multi-rate linear repeater with integrated signal conditioning. The four channels operate independently from one another. Each channel includes a continuous-time linear equalizer (CTLE) and a linear output driver, which together compensate for a lossy transmission channel between the source transmitter and the final receiver. The linearity of the data path is specifically designed to preserve any transmit equalization while keeping receiver equalization effective.

The DS160PR410 can be configured three different ways: through control pins (pin mode), SMBus/I²C, or EEPROM. The device is configurable through a single SMBus or I²C port. The DS160PR410 can also act as a SMBus master to configure itself from an EEPROM. Pin-only control can also be used for most applications.

7.2 Functional Block Diagram

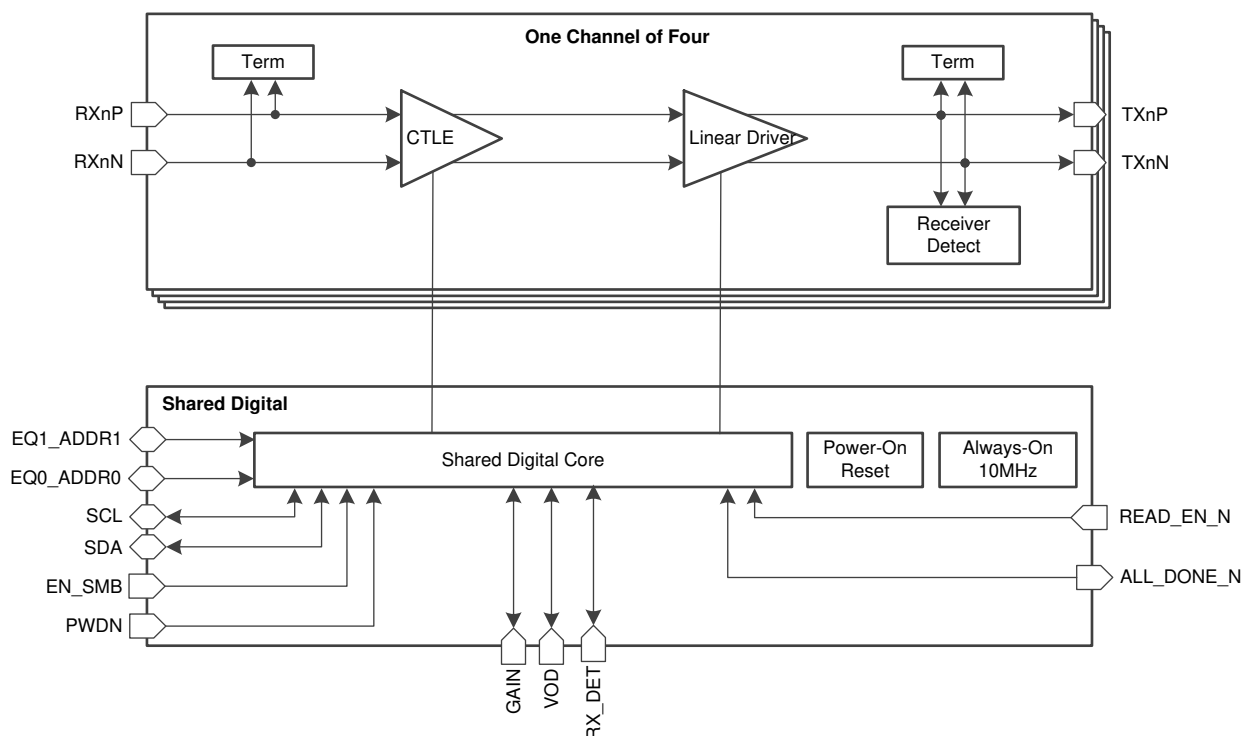

7.3 Feature Description

7.3.1 Linear Equalization

The DS160PR410 receivers feature a continuous-time linear equalizer (CTLE) that applies high-frequency boost and low-frequency attenuation to help equalize the frequency-dependent insertion loss effects of the passive channel. 表 1 shows available equalization boost through EQ0_ADDR0 and EQ1_ADDR1 control pins, when in Pin Control mode (EN_SMB=L0).

表 1. Equalization Control Settings

EQUALIZATION SETTING			TYPICAL EQ BOOST	
INDEX	EQ1_ADDR1	EQ0_ADDR0	@ 4 GHz	@ 8 GHz
0	L0	L0	-0.3	-0.8
1	L0	L1	0.4	1.3
2	L0	L2	3.3	5.7
3	L0	L3	3.8	7.1

Feature Description (接下页)
表 1. Equalization Control Settings (接下页)

EQUALIZATION SETTING			TYPICAL EQ BOOST	
INDEX	EQ1_ADDR1	EQ0_ADDR0	@ 4 GHz	@ 8 GHz
4	L1	L0	4.9	8.4
5	L1	L1	5.2	9.1
6	L1	L2	5.4	9.8
7	L1	L3	6.5	10.7
8	L2	L0	6.7	11.3
9	L2	L1	7.7	12.6
10	L2	L2	8.7	13.6
11	L2	L3	9.1	14.4
12	L3	L0	9.4	15.0
13	L3	L1	10.3	15.9
14	L3	L2	10.6	16.5
15	L3	L3	11.8	17.8

The equalization of the device can also be set by writing to SMBus/I²C registers in slave or master mode. Refer to the [DS160PR410 Programming Guide](#) (SNLU255) for details.

7.3.2 DC Gain

The VOD or GAIN pins can be used to set the overall datapath DC (low frequency) gain of the DS160PR410 as outlined in the [Pin Configuration and Functions](#) section.

It is advised that the DC gain and equalization of the DS160PR410 are set such that the signal swing at DC and high frequency does not exceed the DC and AC linearity ranges of the devices, respectively.

7.3.3 Receiver Detect State Machine

The DS160PR410 deploys an RX detect state machine that governs the RX detection cycle as defined in the PCI express specifications. At power up, after a manually triggered event through PWDN1 and PWDN2 pins (in pin mode), or writing to the relevant I²C / SMBus register, the redriver determines whether or not a valid PCI express termination is present at the far end of the link. The RX_DET pin of DS160PR410 provides additional flexibility for system designers to appropriately set the device in desired mode according to [表 2](#).

If all four channels of DS160PR410 is used for same PCI express link, the PRWDN1 and PWDN2 pin can be shorted and driven together.

表 2. Receiver Detect State Machine Settings

PWDN1 and PWDN2	RXDET	COMMENTS
L	L0	PCI Express RX detection state machine is enabled. RX detection is asserted after 2x valid detections. Pre Detect: Hi-Z, Post Detect: 50 Ω.
L	L1	PCI Express RX detection state machine is enabled. RX detection is asserted after 3x valid detections. Pre Detect: Hi-Z, Post Detect: 50 Ω.
L	L2 (Float)	PCI Express RX detection state machine is enabled. RX detection is asserted after 1x valid detection. Pre Detect: Hi-Z, Post Detect: 50 Ω.

表 2. Receiver Detect State Machine Settings (接下页)

PWDN1 and PWDN2	RXDET	COMMENTS
L	L3	PCI Express RX detection state machine is disabled. Recommended for non PCI Express interface use case where the DS160PR410 is used as buffer with equalization. Always 50 Ω.
H	X	Manual reset, input is high impedance.

7.4 Device Functional Modes

7.4.1 Active PCIe Mode

The device is in normal operation with PCIe state machine enabled by RX_DET=L0/L1/L2. In this mode PWDN1/PWDN2 pins are driven low in a system (for example by PCIE connector "PRSNT" signal). In this mode, the DS160PR410 redrives and equalizes PCIe RX or TX signals to provide better signal integrity.

7.4.2 Active Buffer Mode

The device is in normal operation with PCIe state machine disabled by RX_DET=L3. This mode is recommended for non-PCIe use cases. In this mode the device is working as a buffer to provide linear equalization to improve signal integrity.

7.4.3 Standby Mode

The device is in standby mode invoked by PWDN1/PWDN2=H. In this mode, the device is in standby mode conserving power.

7.5 Programming

7.5.1 Control and Configuration Interface

7.5.1.1 Pin Mode

The DS160PR410 can be fully configured through GPIO/Pin-strap pins. In this mode the device uses 2-level and 4-level pins for device control and signal integrity optimum settings. The [Pin Configuration and Functions](#) section defines the control pins.

7.5.1.1.1 Four-Level Control Inputs

The DS160PR410 has six (GAIN, VOD, EQ1_ADDR1, EQ0_ADDR0, EN_SMB, and RX_DET) 4-level inputs pins that are used to control the configuration of the device. These 4-level inputs use a resistor divider to help set the 4 valid levels and provide a wider range of control settings. External resistors must be of 10% tolerance or better.

表 3. 4-Level Control Pin Settings

LEVEL	SETTING
L0	1 kΩ to GND
L1	13 kΩ to GND
L2	F (Float)
L3	59 kΩ to GND

7.5.1.2 SMBUS/I²C Register Control Interface

If EN_SMB=L3 (SMBus / I²C control mode), the DS160PR410 is configured through a standard I²C or SMBus interface that may operate up to 400 kHz. The slave address of the DS160PR410 is determined by the pin strap settings on the EQ1_ADDR1 and EQ0_ADDR0 pins. The device can be configured for best signal integrity and power settings in the system using the I²C or SMBus interface. The sixteen possible slave addresses (8-bit) for the DS160PR410 are shown in [表 4](#).

表 4. SMBUS/I2C Slave Address Settings

EQ1_ADDR1	EQ0_ADDR0	ADDRESS (DEC)	ADDRESS (HEX)
L0	L0	48	30
L0	L1	50	32
L0	L2	52	34
L0	L3	54	36
L1	L0	56	38
L1	L1	58	3A
L1	L2	60	3C
L1	L3	62	3E
L2	L0	64	40
L2	L1	66	42
L2	L2	68	44
L2	L3	70	46
L3	L0	72	48
L3	L1	74	4A
L3	L2	76	4C
L3	L3	78	4E

The DS160PR410 can also be configured by reading from EEPROM. To enter into this mode SMB_EN must be set to L1. Refer to the [Understanding EEPROM Programming for DS160PR410 PCI-Express Gen-4 Redriver](#) application report (SNLA320) for details.

7.5.1.3 SMBus/I2C Master Mode Configuration (EEPROM Self Load)

To configure the DS160PR410 for SMBus master mode, set the EN_SMB pin to L1. If the DS160PR410 is configured for SMBus master mode, it will remain in the SMBus IDLE state until the READ_EN_N pin is asserted to LOW. After the READ_EN_N pin is driven LOW, the DS160PR410 becomes an SMBus master and attempts to self-configure by reading device settings stored in an external EEPROM (SMBus 8-bit address 0xA0). When the DS160PR410 has finished reading from the EEPROM successfully, it will drive the ALL_DONE_N pin LOW and then change from a SMBus master to a SMBus slave. Not all bits in the register map can be configured through an EEPROM load. Refer to the [Understanding EEPROM Programming for DS160PR410 PCI-Express Gen-4 Redriver](#) application report (SNLA320) for more information.

When designing a system for using the external EEPROM, the user must follow these specific guidelines:

- EEPROM size of 2 kb (256 × 8-bit) is recommended.
- Set EN_SMB = L1, configure for SMBus master mode
- The external EEPROM device address byte must be 0xA0 and capable of 400-kHz operation at 3.3-V supply

图 1 outlines how multiple devices can be configured through single external EEPROM device. 图 1 shows a use case with four DS160PR410, but the user can cascade and number of DS160PR410 devices in a similar way, for brevity pullup resistors (for open-drain outputs) are not shown in the block diagram. Tie the first device's READ_EN_N pin low to automatically initiate EEPROM read at power up. Alternately the READ_EN_N pin of the first device can also be controlled by a microcontroller to initiate the EEPROM read manually. Leave the final device's ALL_DONE_N pin floating, or connect the pin to a microcontroller input to monitor the completion of the final EEPROM read.



图 1. Example Daisy Chain for Multiple Device Single EEPROM Configuration

8 Application and Implementation

注

Information in the following applications sections is not part of the TI component specification, and TI does not warrant its accuracy or completeness. TI's customers are responsible for determining suitability of components for their purposes. Customers should validate and test their design implementation to confirm system functionality.

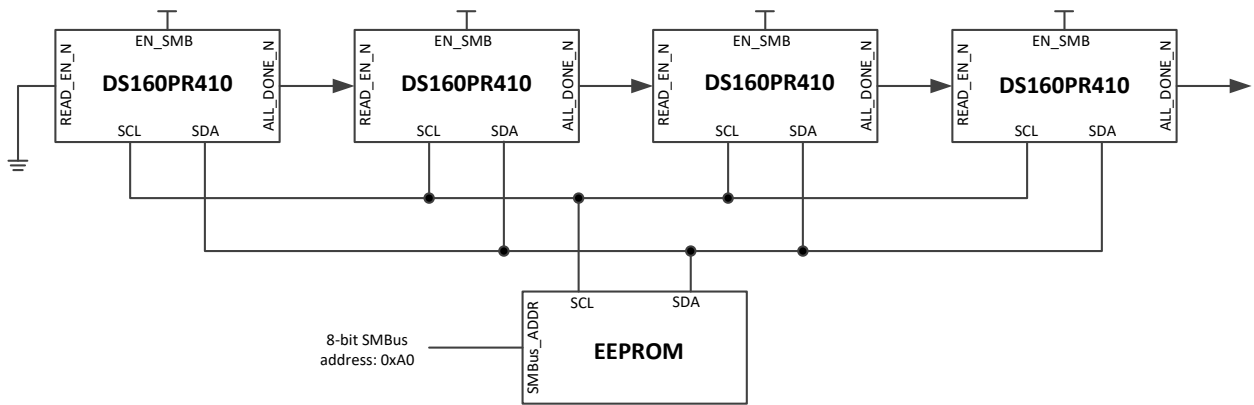
8.1 Application Information

The DS160PR410 is a high-speed linear repeater which extends the reach of differential channels impaired by loss from transmission media like PCBs and cables. It can be deployed in a variety of different systems. The following sections outline typical applications and their associated design considerations.

8.2 Typical Applications

The DS160PR410 is a PCI Express linear redriver that can also be configured as interface agnostic redriver by disabling its RX detect feature. The device can be used in wide range of interfaces including:

- PCI Express
- Ultra Path Interconnect (UPI)
- SATA
- SAS
- Display Port

Typical Applications (接下页)

The DS160PR410 is a protocol agnostic 4-channel linear redriver with PCI Express receiver-detect capability. Its protocol agnostic nature allows it to be used in PCI Express x2, x4, x8, and x16 applications. 图 2 shows how a number of DS160PR410 devices can be used to obtain signal conditioning for PCI Express buses of varying widths. Note all four channels of the DS160PR410 flow in same direction. Therefore, if the device is used for x2 configuration, careful layout consideration is needed. In x2 configuration, the two-channel grouping can be used for PCIe receiver detect. PWDN1 pin puts channels 1 and 2, and PWDN2 pin puts channels 3 and 4 into standby.



图 2. PCI Express x2, x4, x8, and x16 Use Cases Using DS160PR410

ADVANCE INFORMATION

Typical Applications (接下页)

8.2.1 PCIe x4 Lane Configuration

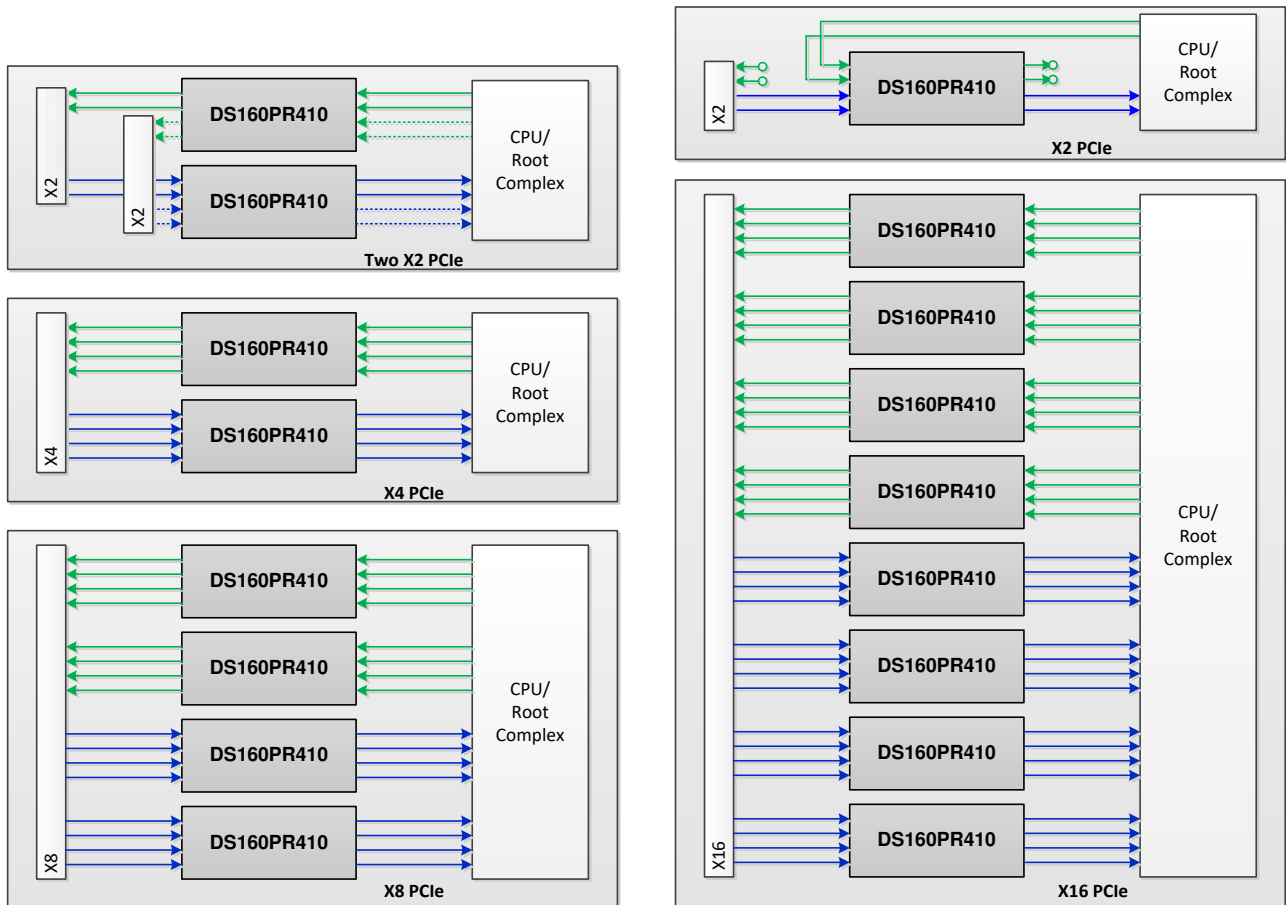
The DS160PR410 can be used in server or motherboard applications to boost transmit and receive signals to increase the reach of the host or root complex processor to PCI Express slots/connectors. The following design recommendations can be used in any lane configuration. 图 3 shows a simplified schematic for x4 configuration.



图 3. Simplified Schematic for PCIe x4 Lane Configuration

ADVANCE INFORMATION

Typical Applications (接下页)

8.2.1.1 Design Requirements

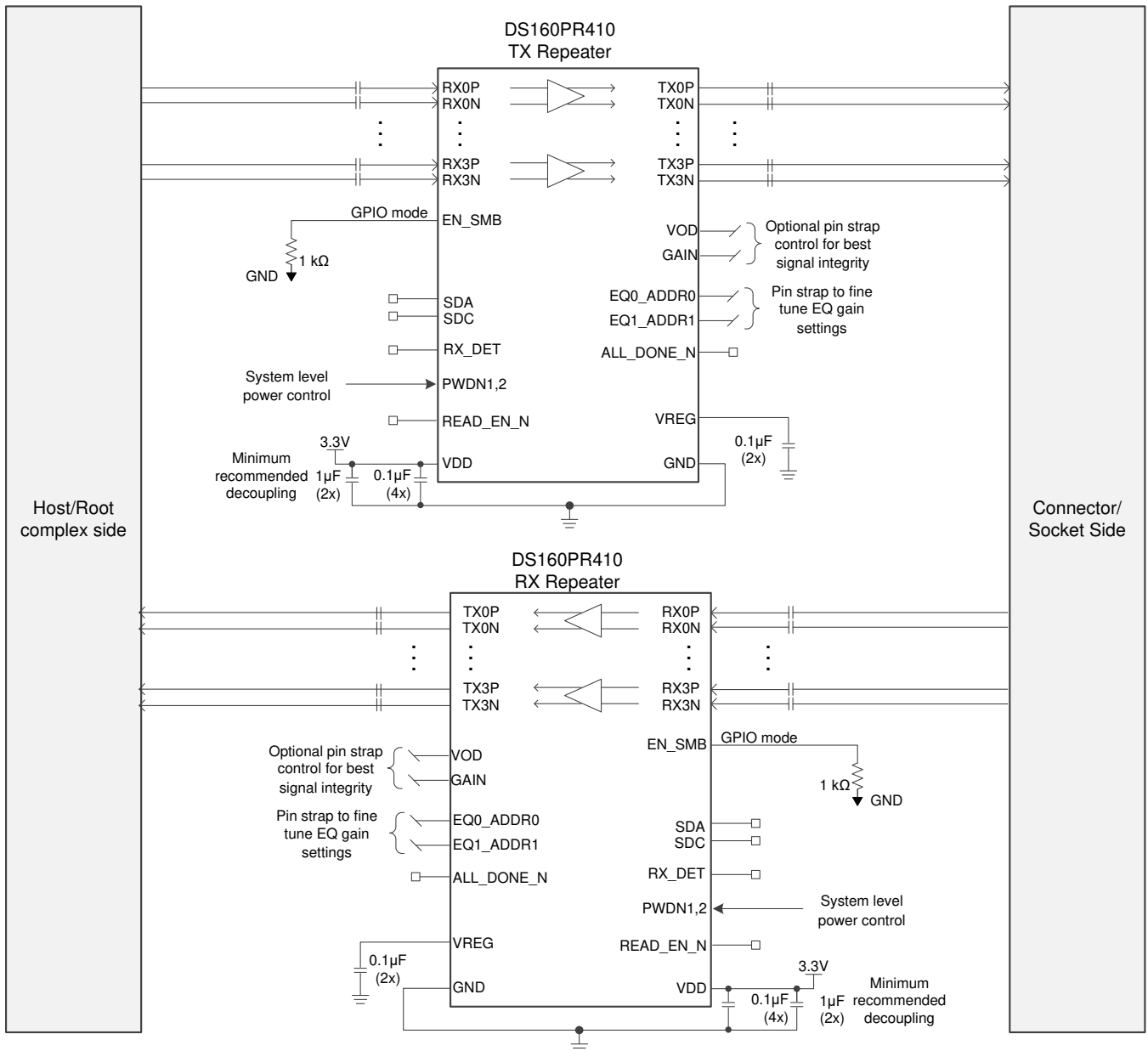
As with any high-speed design, there are many factors which influence the overall performance. The following list indicates critical areas for consideration during design.

- Use 85-Ω impedance traces when interfacing with PCIe CEM connectors. Length matching on the P and N traces should be done on the single-end segments of the differential pair.
- Use a uniform trace width and trace spacing for differential pairs.
- Place AC-coupling capacitors near to the receiver end of each channel segment to minimize reflections.
- For Gen-3 and Gen-4, AC-coupling capacitors of 220 nF are recommended, set the maximum body size to 0402, and add a cutout void on the GND plane below the landing pad of the capacitor to reduce parasitic capacitance to GND.
- Back-drill connector vias and signal vias to minimize stub length.
- Use reference plane vias to ensure a low inductance path for the return current.

8.2.1.2 Detailed Design Procedure

In PCIe Gen-4 and Gen-3 applications, the specification requires Rx-Tx link training to establish and optimize signal conditioning settings at 16 Gbps and 8 Gbps, respectively. In link training, the Rx partner requests a series of FIR – preshoot and deemphasis coefficients (10 Presets) from the Tx partner. The Rx partner includes 7-levels (6 dB to 12 dB) of CTLE followed by a single tap DFE. The link training would pre-condition the signal, with an equalized link between the root-complex and endpoint.

Note that there is no link training in PCIe Gen-1 (2.5 Gbps) or PCIe Gen-2 (5.0 Gbps) applications. The DS160PR410 is placed in between the Tx and Rx. It helps extend the PCB trace reach distance by boosting the attenuated signals with its equalization, which allows the user to recover the signal by the downstream Rx more easily.

For operation in Gen-4 and Gen-3 links, the DS160PR410 transmit outputs are designed to pass the Tx Preset signaling onto the Rx for the PCIe Gen-4 or Gen-3 link to train and optimize the equalization settings. The suggested setting for the DS160PR410 are VOD = 0 dB and DC GAIN = 3.5 dB. Adjustments to the EQ setting should be performed based on the channel loss to optimize the eye opening in the Rx partner. The available EQ gain settings are provided in [表 1](#).

The Tx equalization presets or CTLE and DFE coefficients in the Rx can also be adjusted to further improve the eye opening.

Typical Applications (接下页)

图 4 shows as an example for DS160PR410 Typical Connection Schematic.

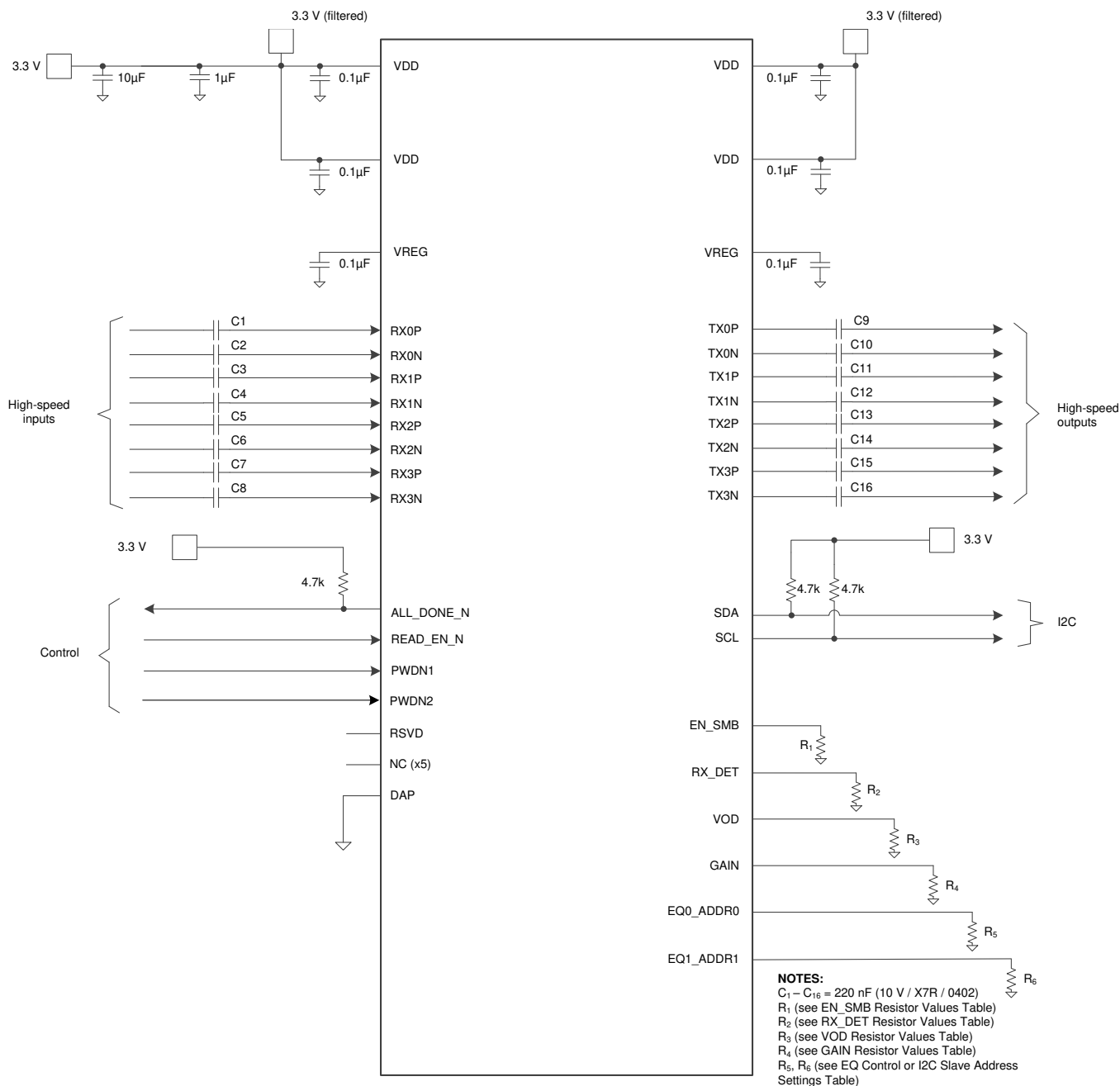

DS160PR410

图 4. DS160PR410 Typical Connection Schematic

ADVANCE INFORMATION

Typical Applications (接下页)

8.2.1.3 Application Curves

The DS160PR410 is a linear redriver that can be used to extend channel reach of a PCIe link. Normally, PCIe-compliant TX and RX are equip with signal-conditioning functions and can handle channel losses of up to 28 dB at 8 GHz. With the DS160PR410, the total channel loss between a PCIe root complex and an end point can be up to 45 dB at 8 GHz.

图 5 shows an electric link that models a single channel of a PCIe link and eye diagrams measured at different locations along the link. The source that models a PCIe TX sends a 16-Gbps PRBS-15 signal with P7 presets. After a transmission channel with -30 dB at 8-GHz insertion loss, the eye diagram is fully closed. The DS160PR410 with its CTLE set to the maximum (18-dB boost) together with the source TX equalization compensates for the losses of the pre-channel (TL1) and opens the eye at the output of the DS160PR410.

The post-channel (TL2) losses mandate the use of PCIe RX equalization functions such as CTLE and DFE that are normally available in PCIe-compliant receivers.



图 5. PCIe Gen-4 Link Reach Extension Using DS160PR410

ADVANCE INFORMATION

Typical Applications (接下页)

8.2.2 DisplayPort Application

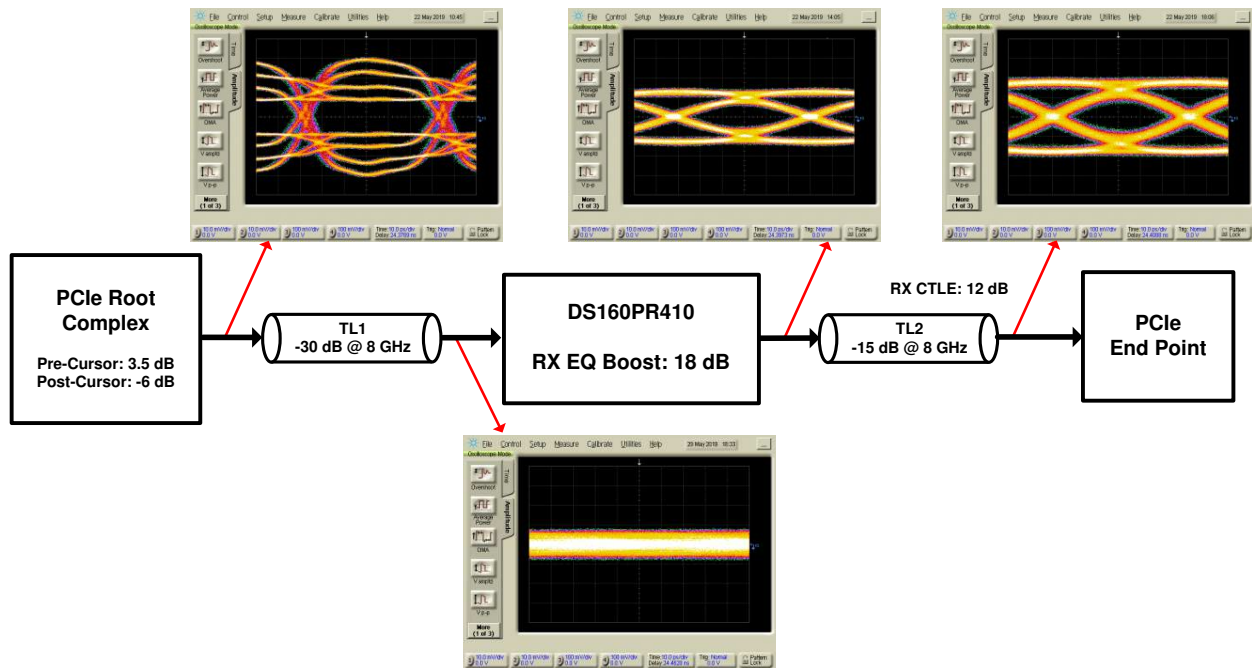
The DS160PR410 can be used as a 4 channel DisplayPort (DP) redriver for data rates up to 20 Gbps. To use the device in a non-PCIe application, the RX_DET pin must be pin-strapped to VDD with 59-kΩ resistor (L3).

The DS160PR410 is a linear redriver which is agnostic to DP link training. The DP link training negotiation between a display source and sink stays effective through the DS160PR410. The redriver becomes part of the electrical channel along with passive traces, cables, and so forth, resulting into optimum source and sink parameters for best electrical link.

图 6 shows a simplified schematic for DisplayPort application. Auxiliary and Hot plug detect (HPD) are bypassed outside of DS160PR410. If system use case requires implementing DP power states, the device must be controlled by the I2C or the pin-strap pins.



图 6. Simplified Schematic for DisplayPort Application

ADVANCE INFORMATION

9 Power Supply Recommendations

Follow these general guidelines when designing the power supply:

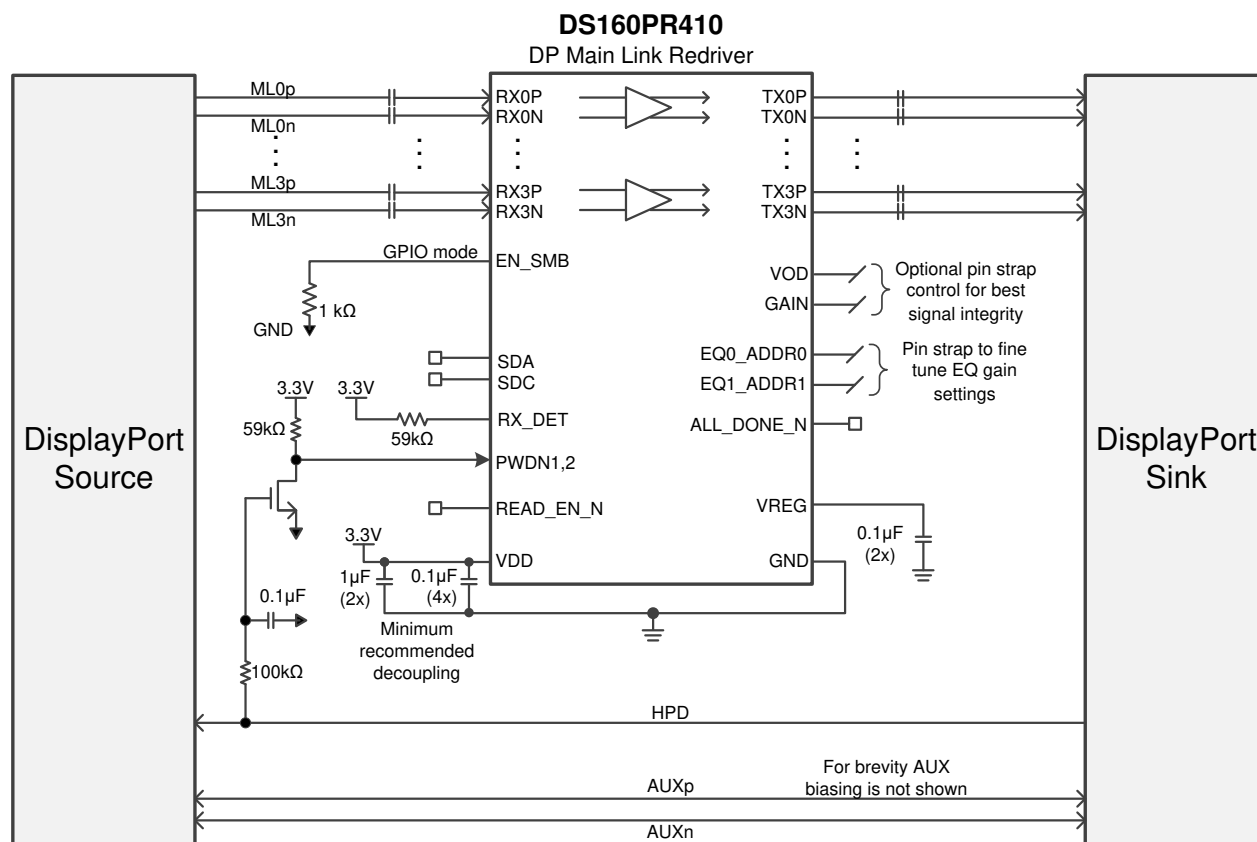
1. The power supply should be designed to provide the operating conditions outlined in the [Recommended Operating Conditions](#) table in terms of DC voltage, AC noise, and start-up ramp time.
2. The DS160PR410 does not require any special power supply filtering, such as ferrite beads, provided that the recommended operating conditions are met. Only standard supply decoupling is required. Typical supply decoupling consists of a 0.1- μ F capacitor per VDD pin, one 1.0- μ F bulk capacitor per device, and one 10- μ F bulk capacitor per power bus that delivers power to one or more DS160PR410 devices. The local decoupling (0.1 μ F) capacitors must be connected as close to the VDD pins as possible and with minimal path to the DS160PR410 ground pad.

10 Layout

10.1 Layout Guidelines

The following guidelines should be followed when designing the layout:

1. Decoupling capacitors should be placed as close to the VDD pins as possible. Placing the decoupling capacitors directly underneath the device is recommended if the board design permits.
2. High-speed differential signals TXnP/TXnN and RXnP/RXnN should be tightly coupled, skew matched, and impedance controlled.
3. Vias should be avoided when possible on the high-speed differential signals. When vias must be used, take care to minimize the via stub, either by transitioning through most/all layers or by back drilling.
4. GND relief can be used (but is not required) beneath the high-speed differential signal pads to improve signal integrity by counteracting the pad capacitance.
5. GND vias should be placed directly beneath the device connecting the GND plane attached to the device to the GND planes on other layers. This has the added benefit of improving thermal conductivity from the device to the board.

10.2 Layout Example

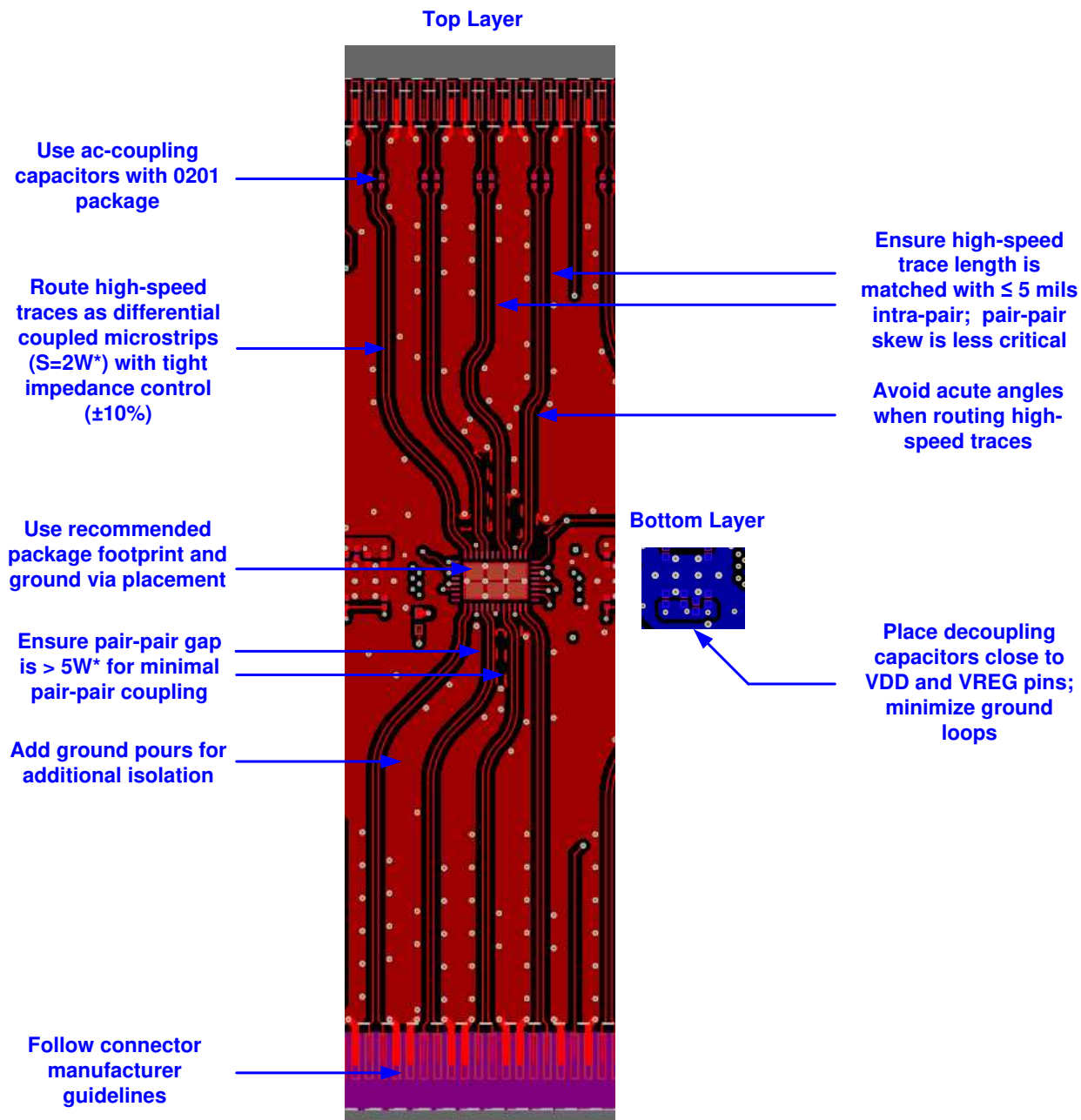

*W is a trace width. S is a gap between adjacent traces.

图 7. DS160PR410 Layout Example - Sub-Section of a PCIe Riser Card With CEM Connectors

ADVANCE INFORMATION

11 器件和文档支持

11.1 文档支持

11.1.1 相关文档

请参阅如下相关文档:

- 德州仪器 (TI), 《DS160PR410 编程指南》(SNLU255)
- 德州仪器 (TI), 《了解 DS160PR410 第 4 代 PCI-Express 转接驱动器的 EEPROM 编程》(SNLA320)

11.2 接收文档更新通知

要接收文档更新通知, 请导航至 ti.com 上的器件产品文件夹。单击右上角的通知我进行注册, 即可每周接收产品信息更改摘要。有关更改的详细信息, 请查看任何已修订文档中包含的修订历史记录。

11.3 社区资源

The following links connect to TI community resources. Linked contents are provided "AS IS" by the respective contributors. They do not constitute TI specifications and do not necessarily reflect TI's views; see TI's [Terms of Use](#).

TI E2E™ Online Community *TI's Engineer-to-Engineer (E2E) Community*. Created to foster collaboration among engineers. At e2e.ti.com, you can ask questions, share knowledge, explore ideas and help solve problems with fellow engineers.

Design Support *TI's Design Support* Quickly find helpful E2E forums along with design support tools and contact information for technical support.

11.4 商标

E2E is a trademark of Texas Instruments.

All other trademarks are the property of their respective owners.

11.5 静电放电警告



ESD 可能会损坏该集成电路。德州仪器 (TI) 建议通过适当的预防措施处理所有集成电路。如果不遵守正确的处理措施和安装程序, 可能会损坏集成电路。

ESD 的损坏小至导致微小的性能降级, 大至整个器件故障。精密的集成电路可能更容易受到损坏, 这是因为非常细微的参数更改都可能会导致器件与其发布的规格不相符。

11.6 Glossary

SLYZ022 — *TI Glossary*.

This glossary lists and explains terms, acronyms, and definitions.

12 机械、封装和可订购信息

以下页面包含机械、封装和可订购信息。这些信息是指定器件的最新可用数据。数据如有变更, 恕不另行通知, 且不会对此文档进行修订。如需获取此数据表的浏览器版本, 请查阅左侧的导航栏。

PACKAGING INFORMATION

Orderable Device	Status (1)	Package Type	Package Drawing	Pins	Package Qty	Eco Plan (2)	Lead finish/ Ball material (6)	MSL Peak Temp (3)	Op Temp (°C)	Device Marking (4/5)	Samples
DS160PR410RNQR	ACTIVE	WQFN	RNQ	40	3000	RoHS & Green	NIPDAU	Level-2-260C-1 YEAR	-40 to 85	PX410	Samples
DS160PR410RNQT	ACTIVE	WQFN	RNQ	40	250	RoHS & Green	NIPDAU	Level-2-260C-1 YEAR	-40 to 85	PX410	Samples

(1) The marketing status values are defined as follows:

ACTIVE: Product device recommended for new designs.

LIFEBUY: TI has announced that the device will be discontinued, and a lifetime-buy period is in effect.

NRND: Not recommended for new designs. Device is in production to support existing customers, but TI does not recommend using this part in a new design.

PREVIEW: Device has been announced but is not in production. Samples may or may not be available.

OBSOLETE: TI has discontinued the production of the device.

(2) **RoHS:** TI defines "RoHS" to mean semiconductor products that are compliant with the current EU RoHS requirements for all 10 RoHS substances, including the requirement that RoHS substance do not exceed 0.1% by weight in homogeneous materials. Where designed to be soldered at high temperatures, "RoHS" products are suitable for use in specified lead-free processes. TI may reference these types of products as "Pb-Free".

RoHS Exempt: TI defines "RoHS Exempt" to mean products that contain lead but are compliant with EU RoHS pursuant to a specific EU RoHS exemption.

Green: TI defines "Green" to mean the content of Chlorine (Cl) and Bromine (Br) based flame retardants meet JS709B low halogen requirements of <=1000ppm threshold. Antimony trioxide based flame retardants must also meet the <=1000ppm threshold requirement.

(3) MSL, Peak Temp. - The Moisture Sensitivity Level rating according to the JEDEC industry standard classifications, and peak solder temperature.

(4) There may be additional marking, which relates to the logo, the lot trace code information, or the environmental category on the device.

(5) Multiple Device Markings will be inside parentheses. Only one Device Marking contained in parentheses and separated by a "~" will appear on a device. If a line is indented then it is a continuation of the previous line and the two combined represent the entire Device Marking for that device.

(6) Lead finish/Ball material - Orderable Devices may have multiple material finish options. Finish options are separated by a vertical ruled line. Lead finish/Ball material values may wrap to two lines if the finish value exceeds the maximum column width.

Important Information and Disclaimer:The information provided on this page represents TI's knowledge and belief as of the date that it is provided. TI bases its knowledge and belief on information provided by third parties, and makes no representation or warranty as to the accuracy of such information. Efforts are underway to better integrate information from third parties. TI has taken and continues to take reasonable steps to provide representative and accurate information but may not have conducted destructive testing or chemical analysis on incoming materials and chemicals. TI and TI suppliers consider certain information to be proprietary, and thus CAS numbers and other limited information may not be available for release.

In no event shall TI's liability arising out of such information exceed the total purchase price of the TI part(s) at issue in this document sold by TI to Customer on an annual basis.

TAPE AND REEL INFORMATION

QUADRANT ASSIGNMENTS FOR PIN 1 ORIENTATION IN TAPE

*All dimensions are nominal

Device	Package Type	Package Drawing	Pins	SPQ	Reel Diameter (mm)	Reel Width W1 (mm)	A0 (mm)	B0 (mm)	K0 (mm)	P1 (mm)	W (mm)	Pin1 Quadrant
DS160PR410RNQR	WQFN	RNQ	40	3000	330.0	12.4	4.3	6.3	1.1	8.0	12.0	Q2
DS160PR410RNQT	WQFN	RNQ	40	250	180.0	12.4	4.3	6.3	1.1	8.0	12.0	Q2

TAPE AND REEL BOX DIMENSIONS

*All dimensions are nominal

Device	Package Type	Package Drawing	Pins	SPQ	Length (mm)	Width (mm)	Height (mm)
DS160PR410RNQR	WQFN	RNQ	40	3000	367.0	367.0	35.0
DS160PR410RNQT	WQFN	RNQ	40	250	210.0	185.0	35.0

RNQ0040A

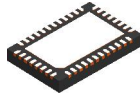

PACKAGE OUTLINE

WQFN - 0.8 mm max height

PLASTIC QUAD FLATPACK - NO LEAD

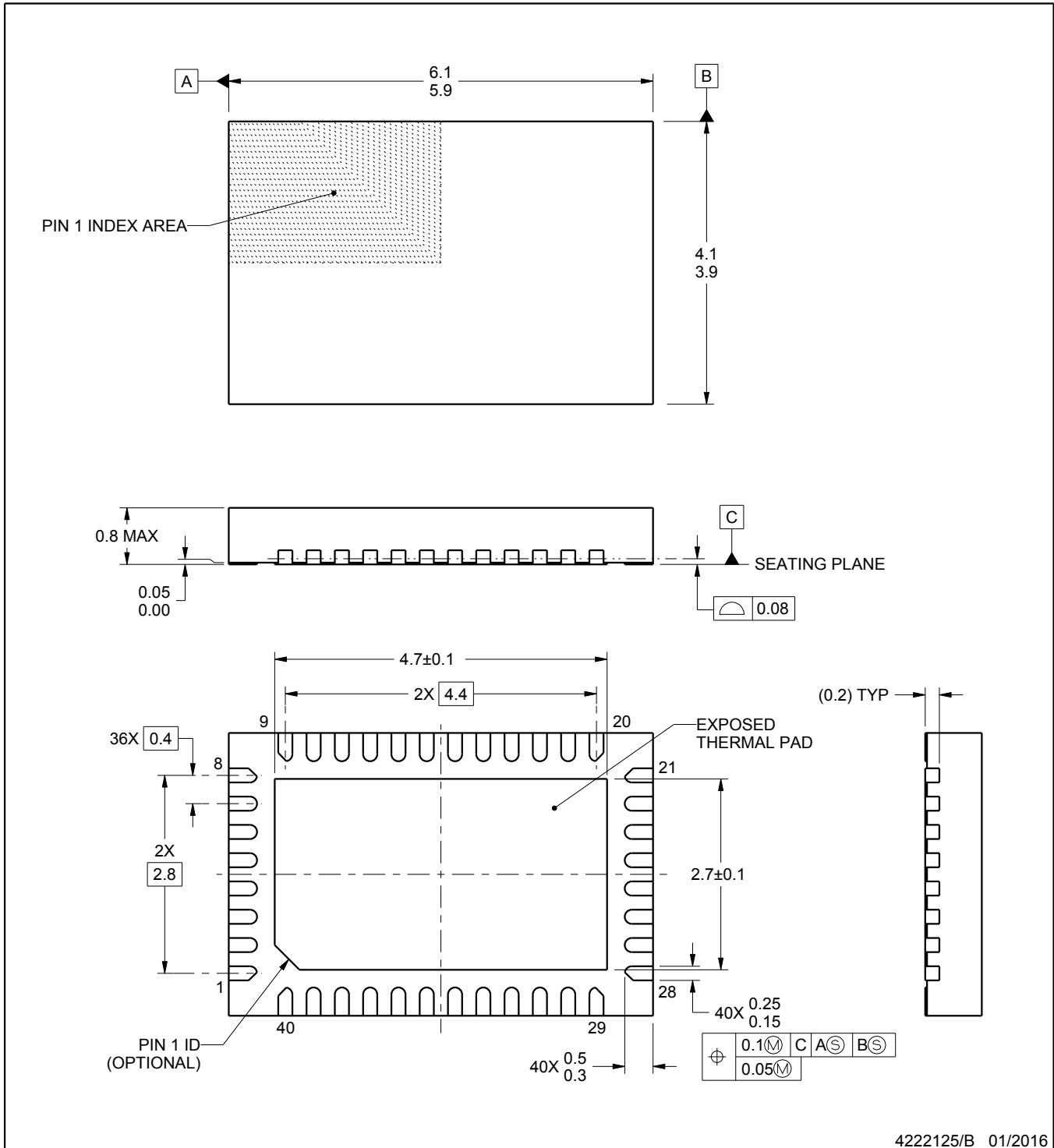

4222125/B 01/2016

NOTES:

1. All linear dimensions are in millimeters. Any dimensions in parenthesis are for reference only. Dimensioning and tolerancing per ASME Y14.5M.
2. This drawing is subject to change without notice.
3. The package thermal pad must be soldered to the printed circuit board for thermal and mechanical performance.

EXAMPLE BOARD LAYOUT

RNQ0040A

WQFN - 0.8 mm max height

PLASTIC QUAD FLATPACK - NO LEAD

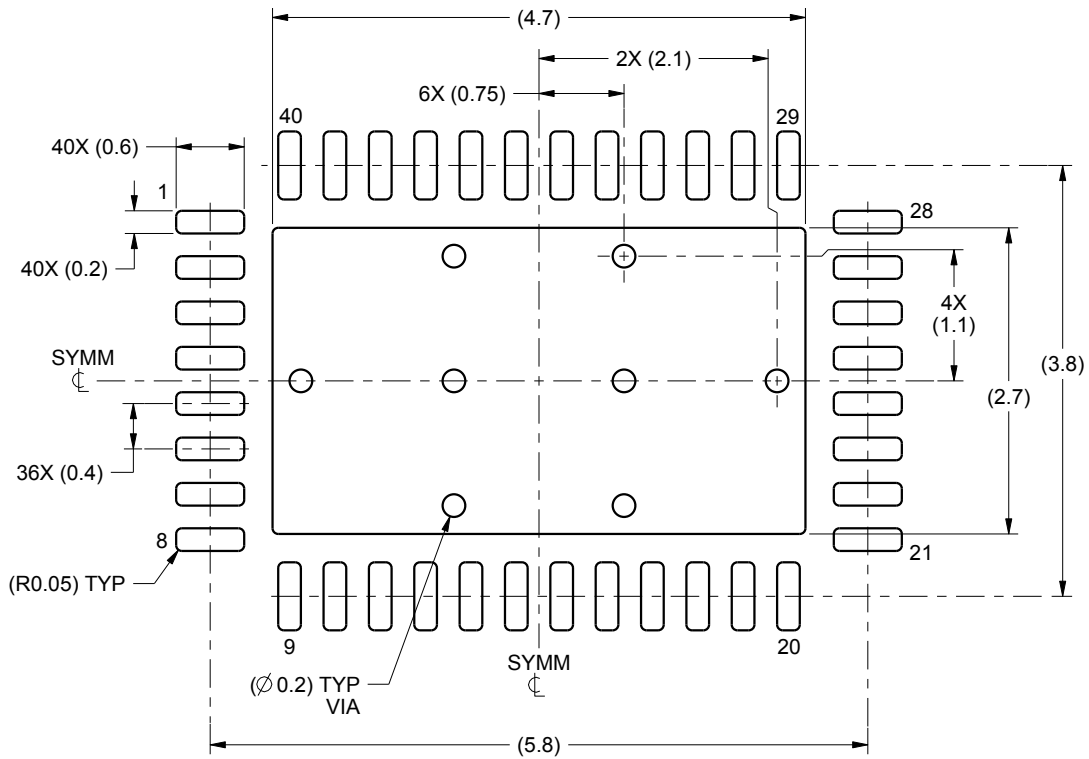

LAND PATTERN EXAMPLE
SCALE:15X

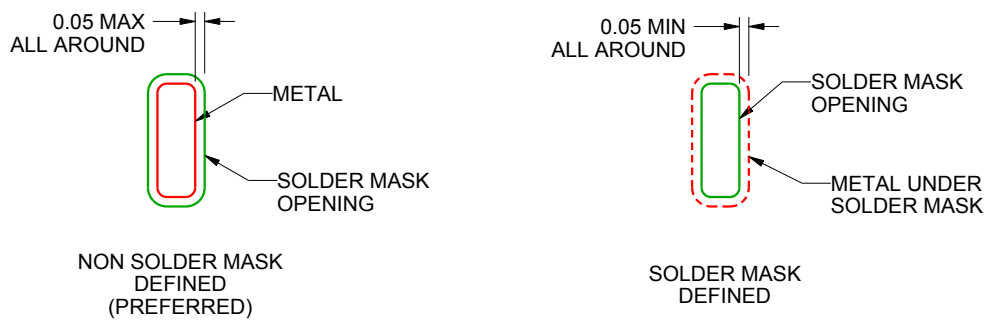

SOLDER MASK DETAILS

4222125/B 01/2016

NOTES: (continued)

4. This package is designed to be soldered to a thermal pad on the board. For more information, see Texas Instruments literature number SLUA271 (www.ti.com/lit/slua271).

EXAMPLE STENCIL DESIGN

RNQ0040A

WQFN - 0.8 mm max height

PLASTIC QUAD FLATPACK - NO LEAD

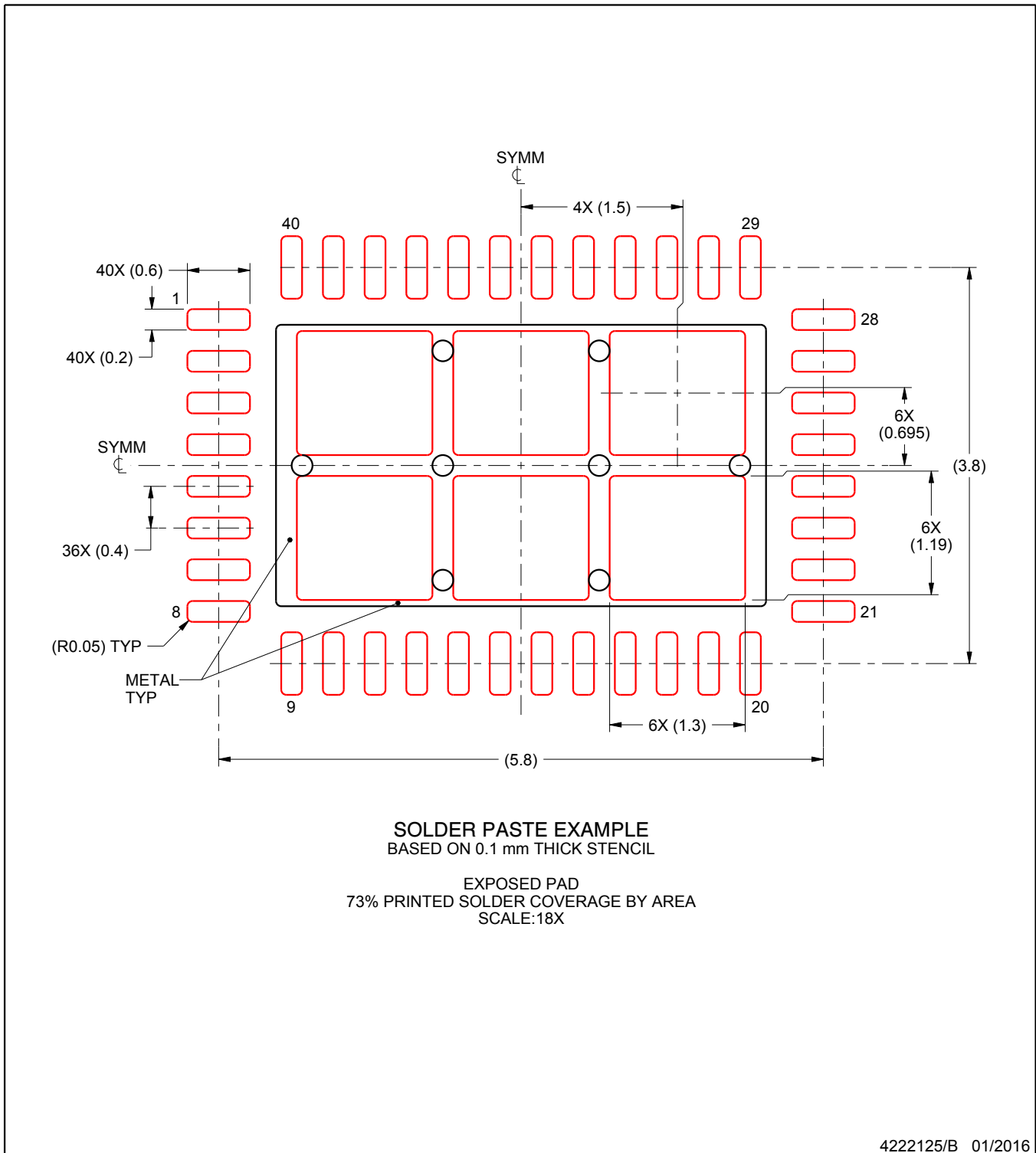

NOTES: (continued)

5. Laser cutting apertures with trapezoidal walls and rounded corners may offer better paste release. IPC-7525 may have alternate design recommendations.

重要声明和免责声明

TI“按原样”提供技术和可靠性数据（包括数据表）、设计资源（包括参考设计）、应用或其他设计建议、网络工具、安全信息和其他资源，不保证没有瑕疵且不做任何明示或暗示的担保，包括但不限于对适销性、某特定用途方面的适用性或不侵犯任何第三方知识产权的暗示担保。

这些资源可供使用 TI 产品进行设计的熟练开发人员使用。您将自行承担以下全部责任：(1) 针对您的应用选择合适的 TI 产品，(2) 设计、验证并测试您的应用，(3) 确保您的应用满足相应标准以及任何其他功能安全、信息安全、监管或其他要求。

这些资源如有变更，恕不另行通知。TI 授权您仅可将这些资源用于研发本资源所述的 TI 产品的应用。严禁对这些资源进行其他复制或展示。您无权使用任何其他 TI 知识产权或任何第三方知识产权。您应全额赔偿因在这些资源的使用中对 TI 及其代表造成的任何索赔、损害、成本、损失和债务，TI 对此概不负责。

TI 提供的产品受 [TI 的销售条款](#) 或 [ti.com](#) 上其他适用条款/TI 产品随附的其他适用条款的约束。TI 提供这些资源并不会扩展或以其他方式更改 TI 针对 TI 产品发布的适用的担保或担保免责声明。

TI 反对并拒绝您可能提出的任何其他或不同的条款。

邮寄地址：Texas Instruments, Post Office Box 655303, Dallas, Texas 75265
Copyright © 2021，德州仪器 (TI) 公司