

DS30EA101 0.15 至 3.125Gbps 自适应电缆均衡器

 查询样品: [DS30EA101](#)

特性

- 同轴电缆和双绞线电缆的自动均衡
- **150Mbps 至 3.125Gbps** 的数据速率
- 支持标清 (SD) 和高清 (HD) 视频分辨率
- 功耗: 典型值为 **115mW**
- 工业温度范围: **-40°C 至 +85°C**

应用范围

- 电缆延长
- 数据恢复均衡
- 安全和监控

说明

DS30EA101 是一款自适应电缆均衡器, 此均衡器针对铜电缆上的均衡数据传输进行了优化。此均衡器运行在 150Mbps 至 3.125Gbps 的数据速率范围内, 并且自动适应以均衡任一长度电缆上 (从零米至 1.5GHz 时信号衰减为 50dB 的电缆长度) 发送的信号。

DS30EA101 可实现单端或差分输入。这样可实现同轴电缆以及双绞线电缆上的信号均衡。

额外特性包括信号丢失 (LOS) 检测和输出使能, 当二者连接在一起时, 在没有输入信号出现的时候, 禁用输出。

DS30EA101 由一个单个 2.5V 电源供电, 功耗 115mW (典型值)。它运行在 -40°C 至 +85°C 的全工业温度范围内, 并且采用 4mm x 4mm 16 引脚超薄型四方扁平无引线 (WQFN) 封装。

典型应用

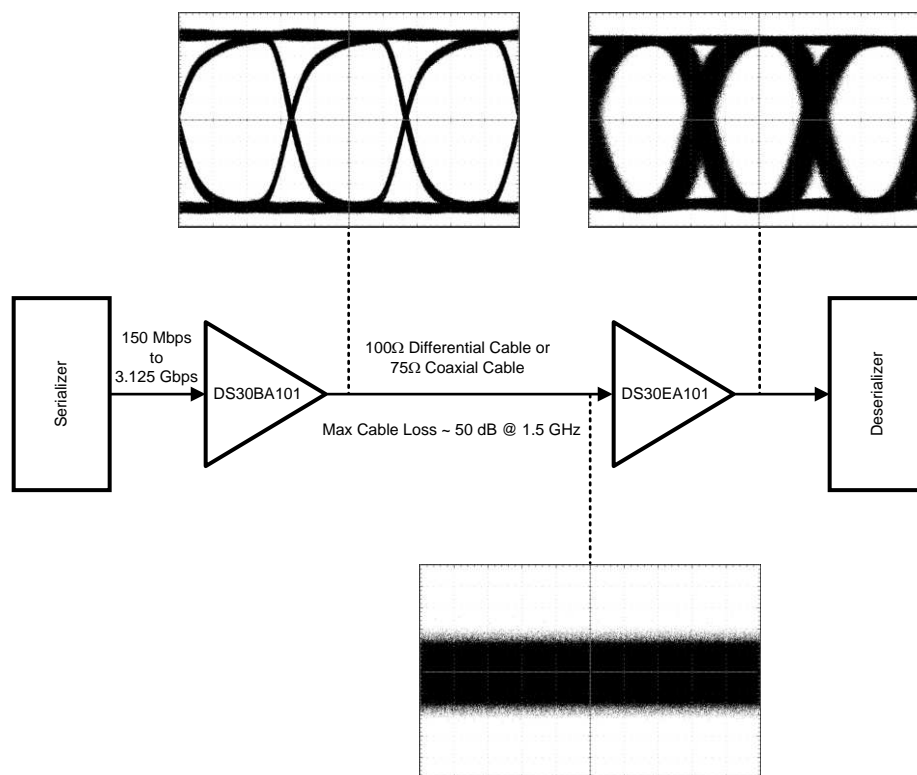

Please be aware that an important notice concerning availability, standard warranty, and use in critical applications of Texas Instruments semiconductor products and disclaimers thereto appears at the end of this data sheet.

All trademarks are the property of their respective owners.

连接图

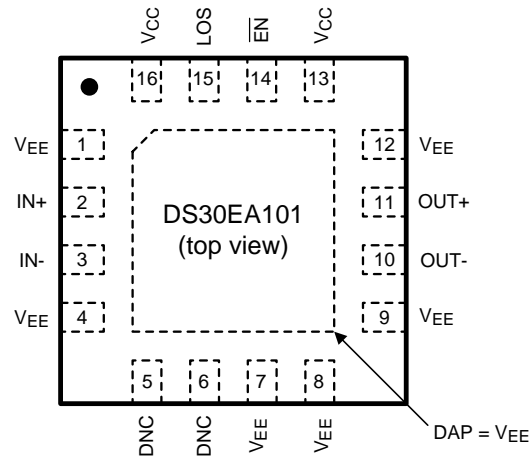

外露裸片连接垫是用于这个器件的一个负电端子。它应该被连接至负电源电压。

**图 1. 16 引脚 WQFN 封装
请见封装编号 RUM0016A**

引脚说明

引脚	名称	I/O, 类型	说明
1	V _{EE}	接地	负电源（接地）。
2	IN+	I, 数据	非反相输入。
3	IN-	I, 数据	反相输入。
4	V _{EE}	接地	负电源（接地）。
5	DNC	不可用	不要连接 - 保持打开。
6	DNC	不可用	不要连接 - 保持打开。
7	V _{EE}	接地	负电源（接地）。
8	V _{EE}	接地	负电源（接地）。
9	V _{EE}	接地	负电源（接地）。
10	OUT-	O, 低压差分信号 (LVDS)	反相输出。
11	OUT+	O, LVDS	非反相输出。
12	V _{EE}	接地	负电源（接地）。
13	V _{CC}	功率	正电源 (+2.5V)。
14	\overline{EN}	I, LVCMOS	输出使能。LOS 可被接至这个引脚, 在没有输入信号出现时禁止输出。这个引脚有一个内部下拉。 H = 输出被禁用。 L = 输出被启用。
15	LOS	O, LVCMOS	信号丢失。 H = 没有检测到输入信号。 L = 检测到输入信号。
16	V _{CC}	电源	正电源 (+2.5V)。
DAP	V _{EE}	接地	将外露 DAP 连接至负电源（接地）。



These devices have limited built-in ESD protection. The leads should be shorted together or the device placed in conductive foam during storage or handling to prevent electrostatic damage to the MOS gates.

Absolute Maximum Ratings⁽¹⁾

Supply Voltage	3.1V
Input Voltage (all inputs)	-0.3V to $V_{CC}+0.3V$
Storage Temperature Range	-65°C to +150°C
Junction Temperature	+125°C
Package Thermal Resistance θ_{JA} 16-pin WQFN θ_{JC} 16-pin WQFN	+40°C/W +6°C/W
ESD Rating (HBM)	$\geq \pm 6$ kV
ESD Rating (MM)	$\geq \pm 300V$
ESD Rating (CDM)	$\geq \pm 2$ kV

- (1) "Absolute Maximum Ratings" indicate limits beyond which damage to the device may occur, including inoperability and degradation of device reliability and/or performance. Functional operation of the device and/or non-degradation at the Absolute Maximum Ratings or other conditions beyond those indicated in the Recommended Operating Conditions is not implied. The Recommended Operating Conditions indicate conditions at which the device is functional and the device should not be operated beyond such conditions.

Recommended Operating Conditions

Supply Voltage (V_{CC})	2.5V $\pm 5\%$
Input Coupling Capacitance	1.0 μF
Operating Free Air Temperature (T_A)	-40°C to +85°C

DC Electrical Characteristics

Over recommended supply voltage and operating temperature ranges, unless otherwise specified.⁽¹⁾⁽²⁾

Parameter		Test Conditions	Reference	Min	Typ	Max	Units
V_{IN}	Input Voltage	0m cable length	IN+, IN-	720	800	880	mV _{P-P}
V_{SS}	Steady State Differential Output Voltage	100 Ω load, Figure 2	OUT+, OUT-	500	700	900	mV _{P-P}
V_{OD}	Differential Output Voltage			250	350	450	mV
ΔV_{OD}	Change in Magnitude of V_{OD} for Complimentary Output States					50	mV
V_{OS}	Offset Voltage			1.1	1.2	1.35	V
ΔV_{OS}	Change in Magnitude of V_{OS} for Complimentary Output States					50	mV
I_{OS}	Output Short Circuit Current						
V_{IH}	Input Voltage High Level		\overline{EN}	1.7		V_{CC}	V
V_{IL}	Input Voltage Low Level			V_{EE}		0.7	V
V_{OH}	Output Voltage High Level	$I_{OH} = -2$ mA	LOS	2.0			V
V_{OL}	Output Voltage Low Level	$I_{OL} = +2$ mA				0.2	V
I_{CC}	Supply Current				45	65	mA

- (1) The Electrical Characteristics tables list ensured specifications under the listed Recommended Operating Conditions except as otherwise modified or specified by the Electrical Characteristics Conditions and/or Notes. Typical specifications are estimations only and are not ensured.
- (2) Typical values represent most likely parametric norms at $V_{CC} = +2.5V$, $T_A = +25^\circ C$, and at the Recommended Operating Conditions at the time of product characterization and are not ensured.

AC Electrical Characteristics

Over recommended supply voltage and operating temperature ranges, unless otherwise specified.⁽¹⁾⁽²⁾

Parameter		Test Conditions	Reference	Min	Typ	Max	Units
DR _{IN}	Input Data Rate		IN+, IN-	150		3125	Mbps
t _{JIT}	Total Jitter at BER 10 ⁻¹² ⁽³⁾	3.125 Gbps, 0-10 meters CAT6			0.35		UI
		2.5 Gbps, 0-25 meters CAT6			0.35		UI
		1.5 Gbps, 0-50 meters CAT6			0.35		UI
		3.125 Gbps, 0-100 meters RG59			0.3		UI
		2.5 Gbps, 0-110 meters RG59			0.35		UI
		1.5 Gbps, 0-120 meters RG59			0.2		UI
t _{TLH}	Transition Time Low to High	20% - 80%, 100Ω load, ⁽⁴⁾ , Figure 2	OUT+, OUT-		90	130	ps
t _{THL}	Transition Time High to Low				90	130	ps

- (1) The Electrical Characteristics tables list ensured specifications under the listed Recommended Operating Conditions except as otherwise modified or specified by the Electrical Characteristics Conditions and/or Notes. Typical specifications are estimations only and are not ensured.
- (2) Typical values represent most likely parametric norms at V_{CC} = +2.5V, T_A = +25°C, and at the Recommended Operating Conditions at the time of product characterization and are not ensured.
- (3) The total jitter at BER 10⁻¹² is calculated as DJ + (14 x RJ), where DJ is deterministic jitter and RJ is random jitter. The jitter is expressed as a portion of the unit interval (UI). The UI is the reciprocal of the data rate.
- (4) Specification is ensured by characterization and is not tested in production.

TIMING DIAGRAMS

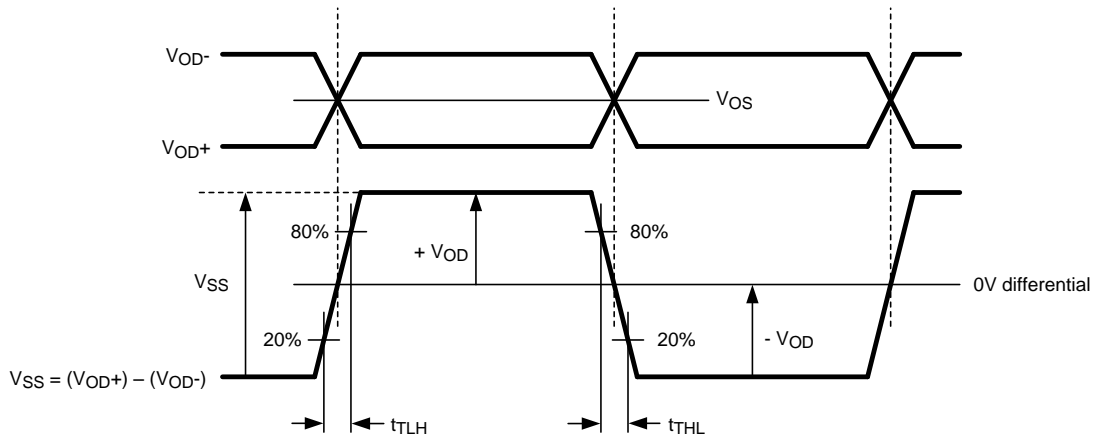

Figure 2. LVDS Output Voltage, Offset, and Timing Parameters

DEVICE OPERATION

The DS30EA101 equalizes data transmitted over copper cables. It automatically adjusts its gain to reverse the effects of the cable loss and restore the original signal. For proper operation, the launch amplitude of the signal going into the cable (the signal amplitude prior to the cable attenuation) must be set appropriately. If the signal is single-ended, its single-ended amplitude must be 800 mV_{P-P} ±10%. If the signal is differential, its differential amplitude must be 800 mV_{P-P} ±10% (400 mV_{P-P} single-ended).

INPUT INTERFACING

The DS30EA101 accepts either differential or single-ended input. The input must be AC coupled. Figure 3 and Figure 4 show the typical configurations for differential input and single-ended input, respectively. For single-ended input, the unused input must be properly terminated as shown.

OUTPUT INTERFACING

The DS30EA101 output signals (OUT+ and OUT-) are internally terminated 100Ω LVDS outputs. These outputs can be DC coupled to most common differential receivers.

LOS AND $\overline{\text{EN}}$

LOS indicates the loss of signal at the DS30EA101 input. LOS is high when no input signal is present and low when a valid input signal is detected.

$\overline{\text{EN}}$ can be used to manually disable or enable the OUT+ and OUT- output signals. Applying a high input to $\overline{\text{EN}}$ will disable the DS30EA101 outputs by forcing the output to a logic 1, and applying a low input to $\overline{\text{EN}}$ will force the outputs to be active. $\overline{\text{EN}}$ has an internal pulldown to enable the outputs by default.

LOS and $\overline{\text{EN}}$ may be tied together to automatically disable the DS30EA101 outputs when no input signal is present.

APPLICATION INFORMATION

CABLE EXTENDER APPLICATION

The DS30EA101 together with the DS30BA101 form a cable extender chipset optimized for extending serial data streams from serializer/deserializer (SerDes) pairs and FPGAs over 100Ω differential cables and 75Ω coaxial cables. Setting the correct DS30BA101 output amplitude and proper cable termination are essential for optimal operation. Figure 3 shows the recommended chipset configuration for 100Ω differential cable and Figure 4 shows the recommended chipset configuration for 75Ω coaxial cable.

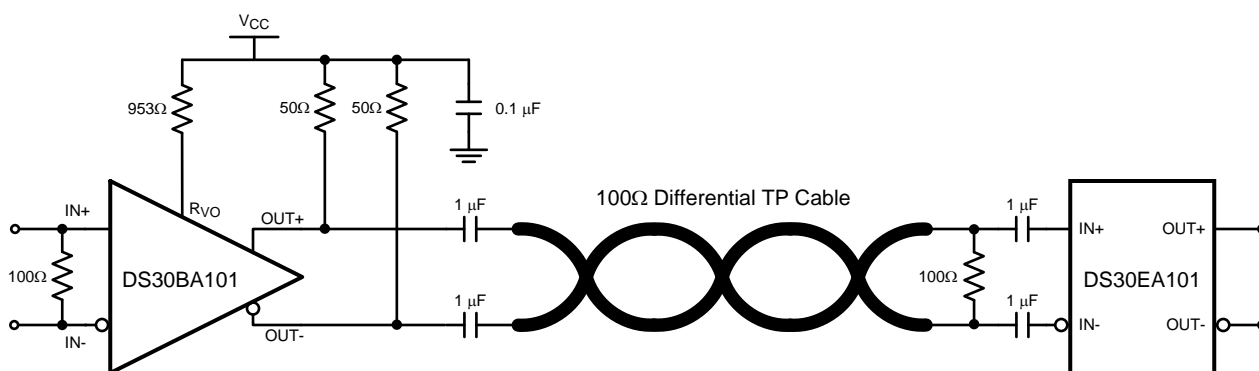

Figure 3. Cable Extender Chipset Application Circuit for 100Ω Differential Cable

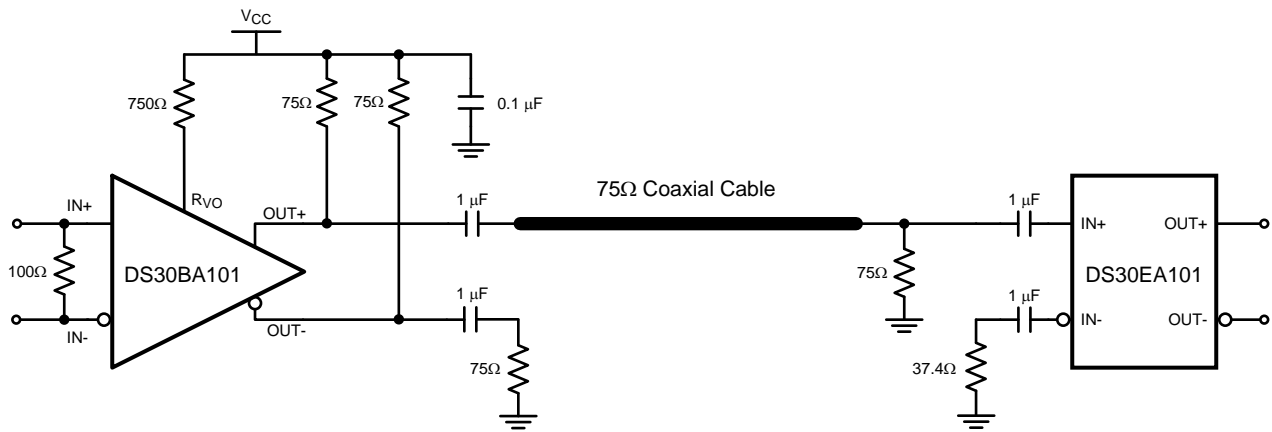

Figure 4. Cable Extender Chipset Application Circuit for 75Ω Coaxial Cable

REVISION HISTORY

Changes from Original (April 2013) to Revision A	Page
• Changed layout of National Data Sheet to TI format	6

PACKAGING INFORMATION

Orderable Device	Status (1)	Package Type	Package Drawing	Pins	Package Qty	Eco Plan (2)	Lead finish/ Ball material (6)	MSL Peak Temp (3)	Op Temp (°C)	Device Marking (4/5)	Samples
DS30EA101SQ/NOPB	ACTIVE	WQFN	RUM	16	1000	RoHS & Green	SN	Level-3-260C-168 HR	-40 to 85	30EA101	Samples
DS30EA101SQE/NOPB	ACTIVE	WQFN	RUM	16	250	RoHS & Green	SN	Level-3-260C-168 HR	-40 to 85	30EA101	Samples
DS30EA101SQX/NOPB	ACTIVE	WQFN	RUM	16	4500	RoHS & Green	SN	Level-3-260C-168 HR	-40 to 85	30EA101	Samples

(1) The marketing status values are defined as follows:

ACTIVE: Product device recommended for new designs.

LIFEBUY: TI has announced that the device will be discontinued, and a lifetime-buy period is in effect.

NRND: Not recommended for new designs. Device is in production to support existing customers, but TI does not recommend using this part in a new design.

PREVIEW: Device has been announced but is not in production. Samples may or may not be available.

OBSELETE: TI has discontinued the production of the device.

(2) **RoHS:** TI defines "RoHS" to mean semiconductor products that are compliant with the current EU RoHS requirements for all 10 RoHS substances, including the requirement that RoHS substance do not exceed 0.1% by weight in homogeneous materials. Where designed to be soldered at high temperatures, "RoHS" products are suitable for use in specified lead-free processes. TI may reference these types of products as "Pb-Free".

RoHS Exempt: TI defines "RoHS Exempt" to mean products that contain lead but are compliant with EU RoHS pursuant to a specific EU RoHS exemption.

Green: TI defines "Green" to mean the content of Chlorine (Cl) and Bromine (Br) based flame retardants meet JS709B low halogen requirements of <=1000ppm threshold. Antimony trioxide based flame retardants must also meet the <=1000ppm threshold requirement.

(3) MSL, Peak Temp. - The Moisture Sensitivity Level rating according to the JEDEC industry standard classifications, and peak solder temperature.

(4) There may be additional marking, which relates to the logo, the lot trace code information, or the environmental category on the device.

(5) Multiple Device Markings will be inside parentheses. Only one Device Marking contained in parentheses and separated by a "~" will appear on a device. If a line is indented then it is a continuation of the previous line and the two combined represent the entire Device Marking for that device.

(6) Lead finish/Ball material - Orderable Devices may have multiple material finish options. Finish options are separated by a vertical ruled line. Lead finish/Ball material values may wrap to two lines if the finish value exceeds the maximum column width.

Important Information and Disclaimer:The information provided on this page represents TI's knowledge and belief as of the date that it is provided. TI bases its knowledge and belief on information provided by third parties, and makes no representation or warranty as to the accuracy of such information. Efforts are underway to better integrate information from third parties. TI has taken and continues to take reasonable steps to provide representative and accurate information but may not have conducted destructive testing or chemical analysis on incoming materials and chemicals. TI and TI suppliers consider certain information to be proprietary, and thus CAS numbers and other limited information may not be available for release.

In no event shall TI's liability arising out of such information exceed the total purchase price of the TI part(s) at issue in this document sold by TI to Customer on an annual basis.

TAPE AND REEL INFORMATION

QUADRANT ASSIGNMENTS FOR PIN 1 ORIENTATION IN TAPE



*All dimensions are nominal

Device	Package Type	Package Drawing	Pins	SPQ	Reel Diameter (mm)	Reel Width W1 (mm)	A0 (mm)	B0 (mm)	K0 (mm)	P1 (mm)	W (mm)	Pin1 Quadrant
DS30EA101SQ/NOPB	WQFN	RUM	16	1000	178.0	12.4	4.3	4.3	1.3	8.0	12.0	Q1
DS30EA101SQE/NOPB	WQFN	RUM	16	250	178.0	12.4	4.3	4.3	1.3	8.0	12.0	Q1
DS30EA101SQX/NOPB	WQFN	RUM	16	4500	330.0	12.4	4.3	4.3	1.3	8.0	12.0	Q1

TAPE AND REEL BOX DIMENSIONS

*All dimensions are nominal

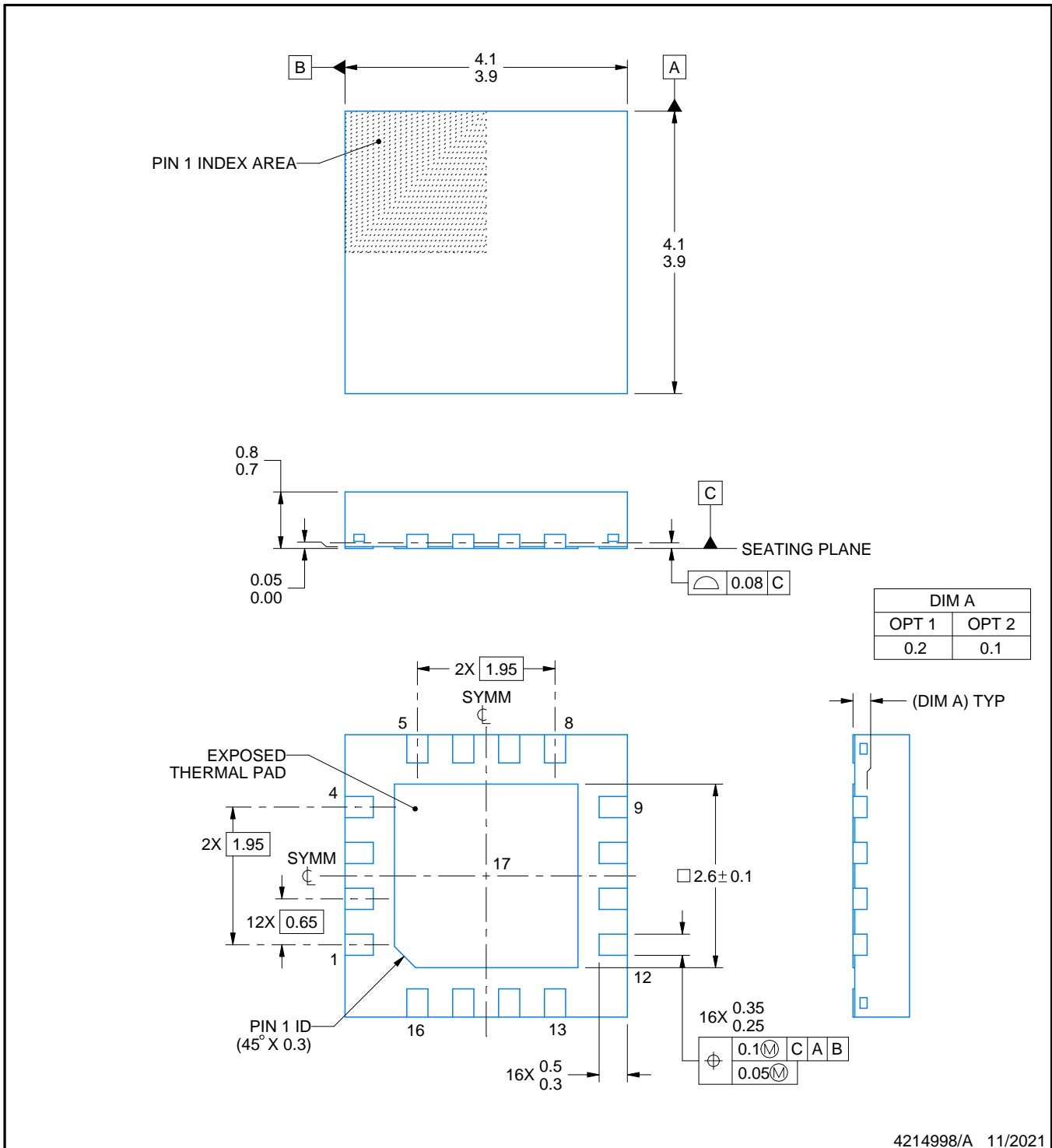
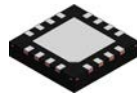
Device	Package Type	Package Drawing	Pins	SPQ	Length (mm)	Width (mm)	Height (mm)
DS30EA101SQ/NOPB	WQFN	RUM	16	1000	208.0	191.0	35.0
DS30EA101SQE/NOPB	WQFN	RUM	16	250	208.0	191.0	35.0
DS30EA101SQX/NOPB	WQFN	RUM	16	4500	853.0	449.0	35.0



4214998/A 11/2021

NOTES:

1. All linear dimensions are in millimeters. Any dimensions in parenthesis are for reference only. Dimensioning and tolerancing per ASME Y14.5M.
2. This drawing is subject to change without notice.
3. The package thermal pad must be soldered to the printed circuit board for thermal and mechanical performance.

EXAMPLE STENCIL DESIGN

RUM0016A

WQFN - 0.8 mm max height

PLASTIC QUAD FLATPACK - NO LEAD

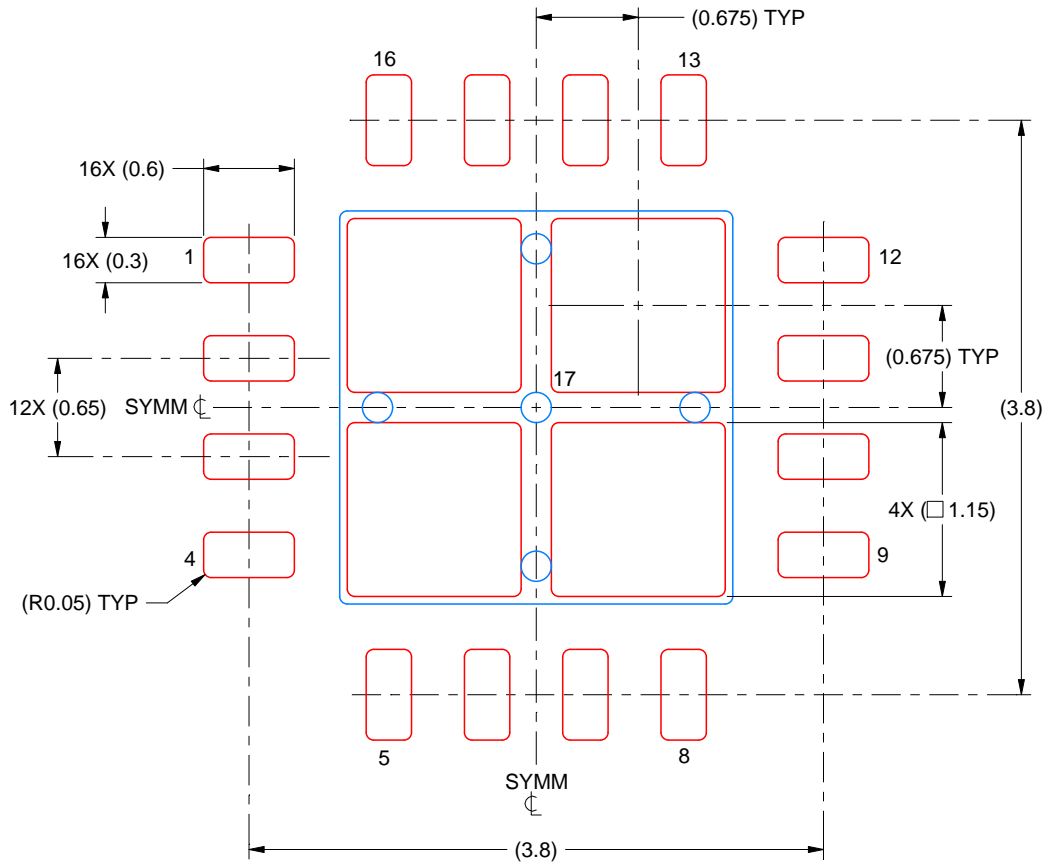

SOLDER PASTE EXAMPLE
BASED ON 0.125 MM THICK STENCIL
SCALE: 20X

EXPOSED PAD 17
78% PRINTED SOLDER COVERAGE BY AREA UNDER PACKAGE

4214998/A 11/2021

NOTES: (continued)

6. Laser cutting apertures with trapezoidal walls and rounded corners may offer better paste release. IPC-7525 may have alternate design recommendations.

重要声明和免责声明

TI“按原样”提供技术和可靠性数据（包括数据表）、设计资源（包括参考设计）、应用或其他设计建议、网络工具、安全信息和其他资源，不保证没有瑕疵且不做任何明示或暗示的担保，包括但不限于对适销性、某特定用途方面的适用性或不侵犯任何第三方知识产权的暗示担保。

这些资源可供使用 TI 产品进行设计的熟练开发人员使用。您将自行承担以下全部责任：(1) 针对您的应用选择合适的 TI 产品，(2) 设计、验证并测试您的应用，(3) 确保您的应用满足相应标准以及任何其他功能安全、信息安全、监管或其他要求。

这些资源如有变更，恕不另行通知。TI 授权您仅可将这些资源用于研发本资源所述的 TI 产品的应用。严禁对这些资源进行其他复制或展示。您无权使用任何其他 TI 知识产权或任何第三方知识产权。您应全额赔偿因在这些资源的使用中对 TI 及其代表造成的任何索赔、损害、成本、损失和债务，TI 对此概不负责。

TI 提供的产品受 [TI 的销售条款](#) 或 [ti.com](#) 上其他适用条款/TI 产品随附的其他适用条款的约束。TI 提供这些资源并不会扩展或以其他方式更改 TI 针对 TI 产品发布的适用的担保或担保免责声明。

TI 反对并拒绝您可能提出的任何其他或不同的条款。

邮寄地址：Texas Instruments, Post Office Box 655303, Dallas, Texas 75265
Copyright © 2021，德州仪器 (TI) 公司