

DS26LV32AT 3V Enhanced CMOS Quad Differential Line Receiver

 Check for Samples: [DS26LV32AT](#)

FEATURES

- Low Power CMOS Design (30 mW typical)
- Interoperable with Existing 5V RS-422 Networks
- Industrial and Military Temperature Range
- Conforms to TIA/EIA-422-B (RS-422) and ITU-T V.11 Recommendation
- 3.3V Operation
- $\pm 7V$ Common Mode Range @ $V_{ID} = 3V$
- $\pm 10V$ Common Mode Range @ $V_{ID} = 0.2V$
- Receiver OPEN Input Failsafe Feature
- Guaranteed AC Parameter:
 - Maximum Receiver Skew: 4 ns
 - Maximum Transition Time: 10 ns
- Pin Compatible with DS26C32AT
- 32 MHz Toggle Frequency
- > 6.5k ESD Tolerance (HBM)

- Available in SOIC and CLGA Packaging
- Standard Microcircuit Drawing (SMD) 5962-98585

DESCRIPTION

The DS26LV32A is a high speed quad differential CMOS receiver that meets the requirements of both TIA/EIA-422-B and ITU-T V.11. The CMOS DS26LV32AT features typical low static I_{CC} of 9 mA which makes it ideal for battery powered and power conscious applications. The TRI-STATE enables, EN and EN*, allow the device to be active High or active Low. The enables are common to all four receivers.

The receiver output (RO) is guaranteed to be High when the inputs are left open. The receiver can detect signals as low as ± 200 mV over the common mode range of $\pm 10V$. The receiver outputs (RO) are compatible with TTL and LVCMOS levels.

Connection Diagram

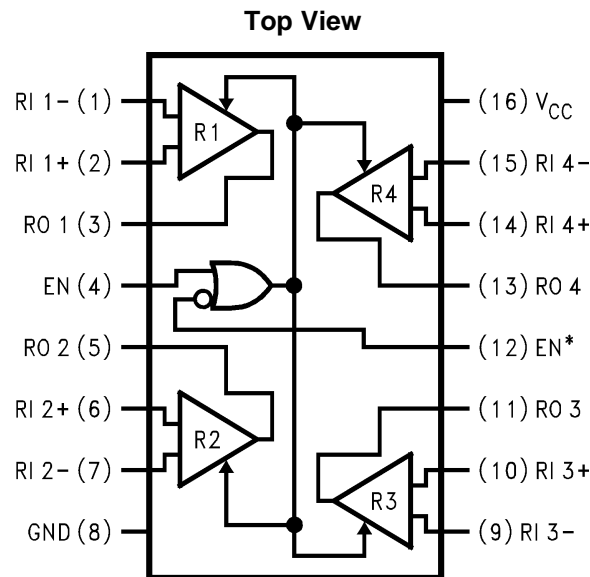

Figure 1.
SOIC Package
See Package Numbers D0016A or NAD0016A



Please be aware that an important notice concerning availability, standard warranty, and use in critical applications of Texas Instruments semiconductor products and disclaimers thereto appears at the end of this data sheet.

All trademarks are the property of their respective owners.

Truth Table⁽¹⁾

Enables		Inputs	Output
EN	EN*	RI+–RI–	RO
L	H	X	Z
All other combinations of enable inputs		$V_{ID} \geq +0.2V$	H
		$V_{ID} \leq -0.2V$	L
		Open ⁽²⁾	H

- (1) L = Logic Low
H = Logic High
X = Irrelevant
Z = TRI-STATE
- (2) Open, not terminated



These devices have limited built-in ESD protection. The leads should be shorted together or the device placed in conductive foam during storage or handling to prevent electrostatic damage to the MOS gates.

Absolute Maximum Ratings⁽¹⁾⁽²⁾

Supply Voltage (V_{CC})	–0.5V to +7V
Enable Input Voltage (EN, EN*)	–0.5V to $V_{CC} + 0.5V$
Receiver Input Voltage (V_{ID} : RI+, RI–)	$\pm 14V$
Receiver Input Voltage (VCM: RI+, RI–)	$\pm 14V$
Receiver Output Voltage (RO)	–0.5V to $V_{CC} + 0.5V$
Receiver Output Current (RO)	± 25 mA Maximum
Maximum Package Power Dissipation @ +25°C	
D0016A Package	1190 mW
NAD0016A Package	1087 mW
Derate D0016A Package 9.8 mW/°C above +25°C	
Derate NAD0016A Package 7.3 mW/°C above +25°C	
Storage Temperature Range	–65°C to +150°C
Lead Temperature Range Soldering (4 Sec.)	+260°C
ESD Ratings (HBM, 1.5 k Ω , 100 pF)	
Receiver Inputs and Enables	≥ 6.5 kV
Other Pins	≥ 2 kV

- (1) “Absolute Maximum ratings” are those values beyond which the safety of the device cannot be guaranteed. They are not meant to imply that the devices should be operated at these limits. The [Electrical Characteristics](#) specifies conditions of device operation.
- (2) If Military/Aerospace specified devices are required, please contact the TI Sales Office/Distributors for availability and specifications.

Recommended Operating Conditions

	Min	Typ	Max	Units
Supply Voltage (V_{CC})	3.0	3.3	3.6	V
Operating Free Air Temperature Range (T_A)				
DS26LV32AT	–40	+25	+85	°C
DS26LV32AW	–55	+25	+125	°C

Electrical Characteristics (1) (2)

Over Supply Voltage and Operating Temperature ranges, unless otherwise specified.

Parameter	Test Conditions	Pin	Min	Typ	Max	Units				
V _{TH}	Differential Input Threshold V _{OUT} = V _{OH} or V _{OL}	RI+, RI-	-200	±17.5	+200	mV				
						mV				
V _{HY}	Hysteresis V _{CM} = 1.5V			35		mV				
V _{IH}	Minimum High Level Input Voltage	EN, EN*	2.0			V				
V _{IL}	Maximum Low Level Input Voltage				0.8	V				
R _{IN}	Input Resistance V _{IN} = -7V, +7V, T _A = -40°C to +85°C (Other Input = GND)		5.0	8.5		kΩ				
			5.0			kΩ				
I _{IN}	Input Current (Other Input = 0V, Power On, or V _{CC} = 0V)	RI+, RI-				T _A = -40°C to +85°C				
						V _{IN} = +10V	0	1.1	1.8	mA
						V _{IN} = +3V	0	0.27		mA
						V _{IN} = 0.5V		-0.02		mA
						V _{IN} = -3V	0	-0.43		mA
						V _{IN} = -10V	0	-1.26	-2.2	mA
						T _A = -55°C to +125°C (3)	0		-1.8	mA
V _{IN} = -0.5V	0		1.8	mA						
V _{IN} = 5.5V										
I _{EN}	Input Current V _{IN} = 0V to V _{CC}	EN, EN*			±1	μA				
V _{OH}	High Level Output Voltage I _{OH} = -6 mA, V _{ID} = +1V		2.4	3		V				
							I _{OH} = -6 mA, V _{ID} = OPEN			
V _{OH}	High Level Output Voltage I _{OH} = -100 μA, V _{ID} = +1V				V _{CC} - 0.1	V				
							I _{OH} = -100 μA, V _{ID} = OPEN			
V _{OL}	Low Level Output Voltage I _{OL} = +6 mA, V _{ID} = -1V				0.13	0.5	V			
I _{OZ}	Output TRI-STATE Leakage Current V _{OUT} = V _{CC} or GND					±50	μA			
								EN = V _{IL} , EN* = V _{IH}		
I _{SC}	Output Short Circuit Current V _O = 0V, V _{ID} ≥ 200 mV (4)		-10	-35	-70	mA				
I _{CC}	Power Supply Current No Load, All RI+, R1- = OPEN, EN, EN* = V _{CC} or GND	V _{CC}				T _A = -40°C to +85°C	9	15	mA	
						T _A = -55°C to +125°C			20	mA

 (1) Current into device pins is defined as positive. Current out of device pins is defined as negative. All voltages are referenced to ground except V_{ID}.

 (2) All typicals are given for: V_{CC} = +3.3V, T_A = +25°C.

(3) This parameter does not meet the TIA/EIA-422-B specification.

(4) Short one output at a time to ground. Do not exceed package.

Switching Characteristics - Industrial ^{(1) (2)}

Over Supply Voltage and -40°C to +85°C Operating Temperature range, unless otherwise specified.

Parameter		Test Conditions	Min	Typ	Max	Units
t_{PHL}	Propagation Delay High to Low	$C_L = 15 \text{ pF}$, $V_{CM} = 1.5\text{V}$ (Figure 2 and Figure 3)	6	17.5	35	ns
t_{PLH}	Propagation Delay Low to High		6	17.8	35	ns
t_r	Rise Time (20% to 80%)			4.1	10	ns
t_f	Fall Time (80% to 20%)			3.3	10	ns
t_{PHZ}	Disable Time	$C_L = 50 \text{ pF}$, $V_{CM} = 1.5\text{V}$ (Figure 4 and Figure 5)			40	ns
t_{PLZ}	Disable Time				40	ns
t_{PZH}	Enable Time				40	ns
t_{PZL}	Enable Time				40	ns
t_{SK1}	Skew, $ t_{PHL} - t_{PLH} $ ⁽³⁾	$C_L = 15 \text{ pF}$, $V_{CM} = 1.5\text{V}$		0.3	4	ns
t_{SK2}	Skew, Pin to Pin ⁽⁴⁾			0.6	4	ns
t_{SK3}	Skew, Part to Part ⁽²⁾			7	17	ns
f_{MAX}	Maximum Operating Frequency ⁽⁵⁾	$C_L = 15 \text{ pF}$, $V_{CM} = 1.5\text{V}$	32			MHz

(1) All typicals are given for: $V_{CC} = +3.3\text{V}$, $T_A = +25^\circ\text{C}$.

(2) t_{SK3} is the difference in propagation delay times between any channels of any devices. This specification (maximum limit) applies to devices within $V_{CC} \pm 0.1\text{V}$ of one another, and a Delta $T_A = \pm 5^\circ\text{C}$ (between devices) within the operating temperature range. This parameter is guaranteed by design and characterization.

(3) t_{SK1} is the $|t_{PHL} - t_{PLH}|$ of a channel.

(4) t_{SK2} is the maximum skew between any two channels within a device, either edge.

(5) All channels switching, Output Duty Cycle criteria is 40%/60% measured at 50%. Input = 1V to 2V, 50% Duty Cycle, $t_r/t_f \leq 5 \text{ ns}$. This parameter is guaranteed by design and characterization.

Switching Characteristics - Military

Over Supply Voltage and -55°C to +125°C Operating Temperature range, unless otherwise specified.

Parameter		Test Conditions	Min	Max	Units
t_{PHL}	Propagation Delay High to Low	$C_L = 50 \text{ pF}$, $V_{CM} = 1.5\text{V}$ (Figure 2 and Figure 3)	6	45	ns
t_{PLH}	Propagation Delay Low to High		6	45	ns
t_{PHZ}	Disable Time	$C_L = 50 \text{ pF}$, $V_{CM} = 1.5\text{V}$ (Figure 4 and Figure 5)		50	ns
t_{PLZ}	Disable Time			50	ns
t_{PZH}	Enable Time			50	ns
t_{PZL}	Enable Time			50	ns
t_{SK1}	Skew, $ t_{PHL} - t_{PLH} $ ⁽¹⁾	$C_L = 50 \text{ pF}$, $V_{CM} = 1.5\text{V}$		6	ns
t_{SK2}	Skew, Pin to Pin ⁽²⁾			6	ns

(1) t_{SK1} is the $|t_{PHL} - t_{PLH}|$ of a channel.

(2) t_{SK2} is the maximum skew between any two channels within a device, either edge.

PARAMETER MEASUREMENT INFORMATION

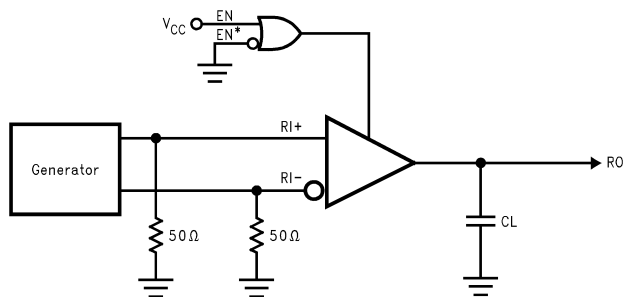

- A. Generator waveform for all tests unless otherwise specified: $f = 1 \text{ MHz}$, Duty Cycle = 50%, $Z_O = 50\Omega$, $t_r \leq 10 \text{ ns}$, $t_f \leq 10 \text{ ns}$.
- B. C_L includes probe and jig capacitance.

Figure 2. Receiver Propagation Delay and Transition Time Test Circuit

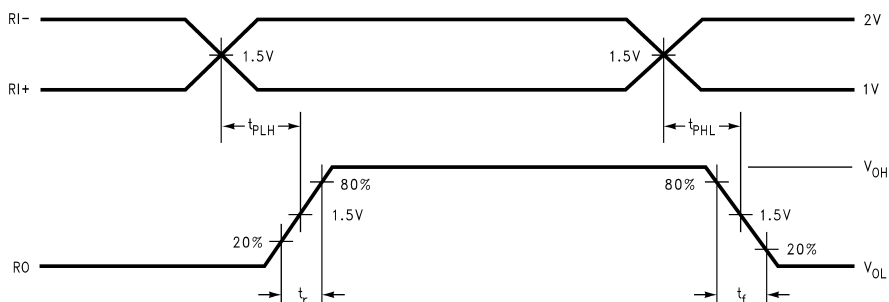

- A. Generator waveform for all tests unless otherwise specified: $f = 1 \text{ MHz}$, Duty Cycle = 50%, $Z_O = 50\Omega$, $t_r \leq 10 \text{ ns}$, $t_f \leq 10 \text{ ns}$.
- B. C_L includes probe and jig capacitance.
- C. For military grade product, $t_r \leq 6\text{ns}$ and $t_f \leq 6\text{ns}$.
- D. For military grade product the measure point is $1/2 V_{CC}$ for t_{PLH} , t_{PHL} , t_{PZL} , and t_{PZH} .

Figure 3. Receiver Propagation Delay and Transition Time Waveform

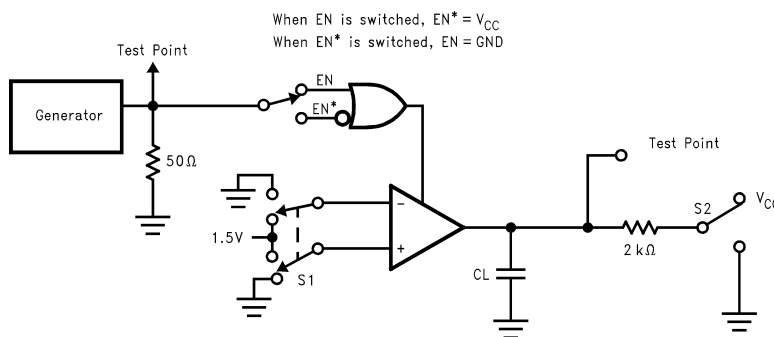
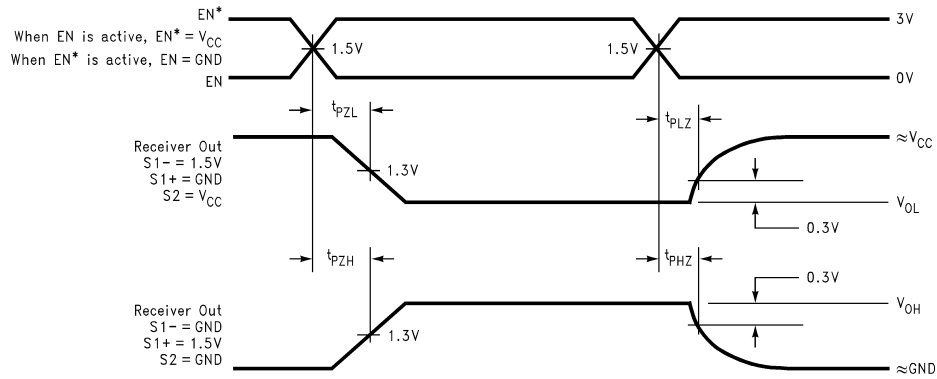

Figure 4. Receiver TRI-STATE Test Circuit



- Generator waveform for all tests unless otherwise specified: $f = 1 \text{ MHz}$, Duty Cycle = 50%, $Z_O = 50\Omega$, $t_r \leq 10 \text{ ns}$, $t_f \leq 10 \text{ ns}$.
- C_L includes probe and jig capacitance.
- For military grade product, $t_r \leq 6\text{ns}$ and $t_f \leq 6\text{ns}$.
- For military grade product the measure point is $1/2 V_{CC}$ for t_{PLH} , t_{PHL} , t_{PZL} , and t_{PZH} .

Figure 5. Receiver TRI-STATE Output Enable and Disable Waveforms

TYPICAL APPLICATION INFORMATION

General application guidelines and hints for differential drivers and receivers may be found in the following application notes:

- AN-214
- AN-457
- AN-805
- AN-847
- AN-903
- AN-912
- AN-916

Power Decoupling Recommendations:

Bypass caps must be used on power pins. High frequency ceramic (surface mount is recommended) 0.1 μF in parallel with 0.01 μF at the power supply pin. A 10 μF or greater solid tantalum or electrolytic should be connected at the power entry point on the printed circuit board.

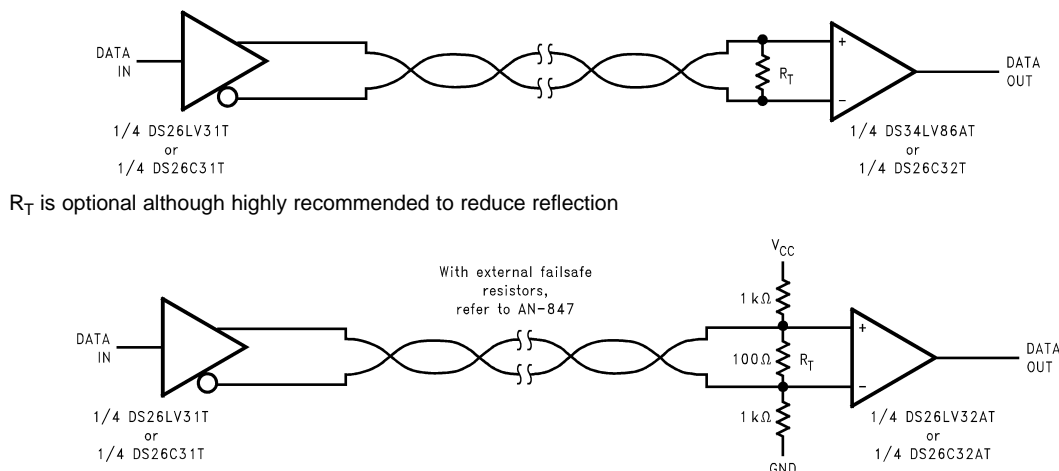

Figure 6. Typical Receiver Connections

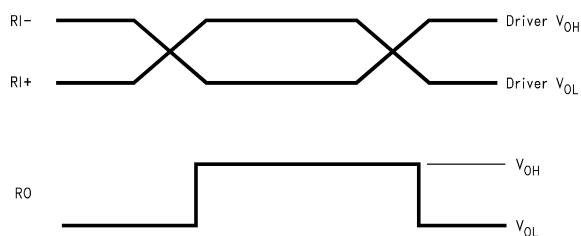

Figure 7. Typical Receiver Output Waveforms

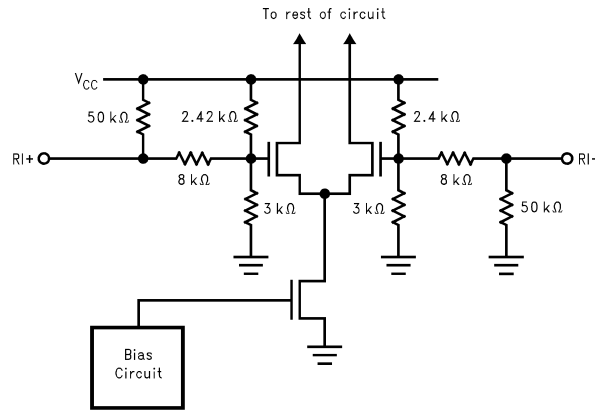

Figure 8. Typical Receiver Input Circuit

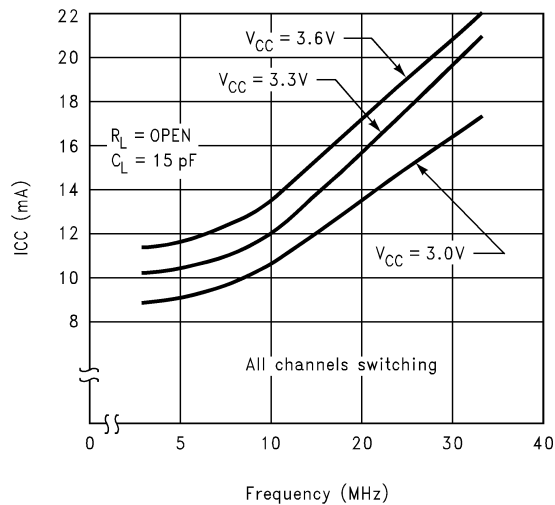

Figure 9. Typical I_{CC} vs Frequency

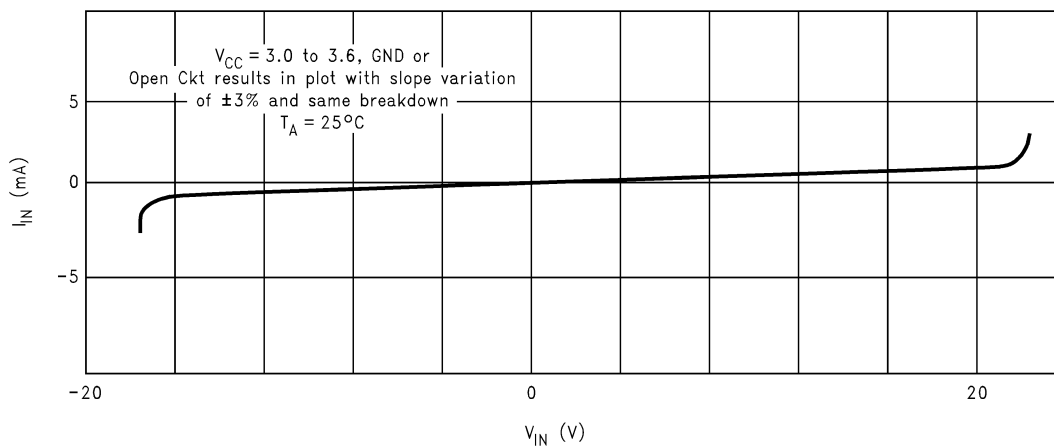

Figure 10. Receiver I_{IN} vs V_{IN} (Power On or Power Off)

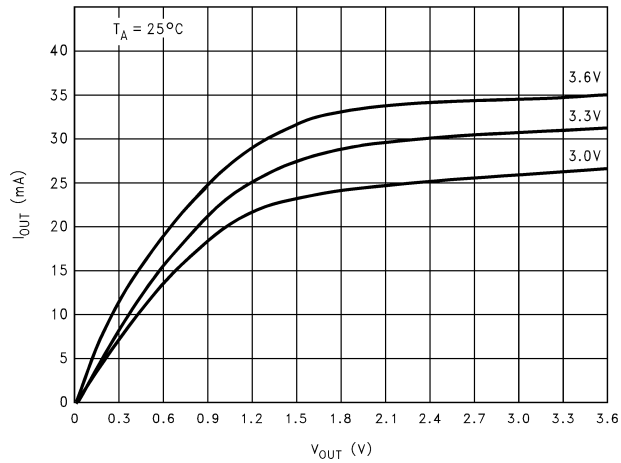

Figure 11. I_{OL} vs V_{OL}

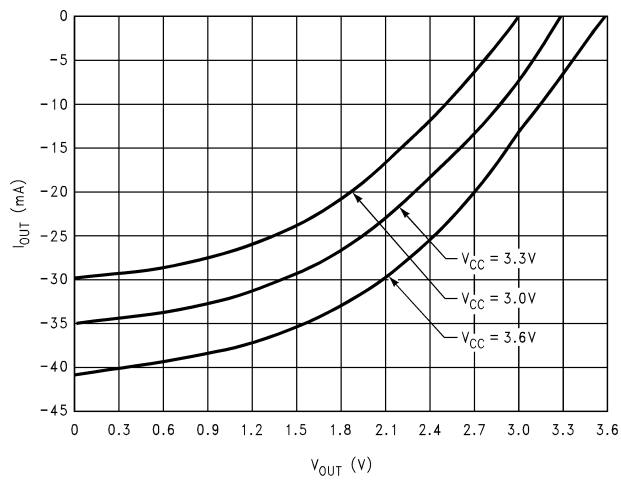



Figure 12. I_{OH} vs V_{OH}

REVISION HISTORY

Changes from Revision B (February 2013) to Revision C	Page
• Changed layout of National Data Sheet to TI format	9

PACKAGING INFORMATION

Orderable Device	Status (1)	Package Type	Package Drawing	Pins	Package Qty	Eco Plan (2)	Lead finish/ Ball material (6)	MSL Peak Temp (3)	Op Temp (°C)	Device Marking (4/5)	Samples
DS26LV32ATM/NOPB	ACTIVE	SOIC	D	16	48	RoHS & Green	SN	Level-1-260C-UNLIM	-40 to 85	DS26LV32A TM	
DS26LV32ATMX/NOPB	ACTIVE	SOIC	D	16	2500	RoHS & Green	SN	Level-1-260C-UNLIM	-40 to 85	DS26LV32A TM	

(1) The marketing status values are defined as follows:

ACTIVE: Product device recommended for new designs.

LIFEBUY: TI has announced that the device will be discontinued, and a lifetime-buy period is in effect.

NRND: Not recommended for new designs. Device is in production to support existing customers, but TI does not recommend using this part in a new design.

PREVIEW: Device has been announced but is not in production. Samples may or may not be available.

OBSOLETE: TI has discontinued the production of the device.

(2) **RoHS:** TI defines "RoHS" to mean semiconductor products that are compliant with the current EU RoHS requirements for all 10 RoHS substances, including the requirement that RoHS substance do not exceed 0.1% by weight in homogeneous materials. Where designed to be soldered at high temperatures, "RoHS" products are suitable for use in specified lead-free processes. TI may reference these types of products as "Pb-Free".

RoHS Exempt: TI defines "RoHS Exempt" to mean products that contain lead but are compliant with EU RoHS pursuant to a specific EU RoHS exemption.

Green: TI defines "Green" to mean the content of Chlorine (Cl) and Bromine (Br) based flame retardants meet JS709B low halogen requirements of <=1000ppm threshold. Antimony trioxide based flame retardants must also meet the <=1000ppm threshold requirement.

(3) MSL, Peak Temp. - The Moisture Sensitivity Level rating according to the JEDEC industry standard classifications, and peak solder temperature.

(4) There may be additional marking, which relates to the logo, the lot trace code information, or the environmental category on the device.

(5) Multiple Device Markings will be inside parentheses. Only one Device Marking contained in parentheses and separated by a "~" will appear on a device. If a line is indented then it is a continuation of the previous line and the two combined represent the entire Device Marking for that device.

(6) Lead finish/Ball material - Orderable Devices may have multiple material finish options. Finish options are separated by a vertical ruled line. Lead finish/Ball material values may wrap to two lines if the finish value exceeds the maximum column width.

Important Information and Disclaimer:The information provided on this page represents TI's knowledge and belief as of the date that it is provided. TI bases its knowledge and belief on information provided by third parties, and makes no representation or warranty as to the accuracy of such information. Efforts are underway to better integrate information from third parties. TI has taken and continues to take reasonable steps to provide representative and accurate information but may not have conducted destructive testing or chemical analysis on incoming materials and chemicals. TI and TI suppliers consider certain information to be proprietary, and thus CAS numbers and other limited information may not be available for release.

In no event shall TI's liability arising out of such information exceed the total purchase price of the TI part(s) at issue in this document sold by TI to Customer on an annual basis.

TAPE AND REEL INFORMATION

QUADRANT ASSIGNMENTS FOR PIN 1 ORIENTATION IN TAPE



*All dimensions are nominal

Device	Package Type	Package Drawing	Pins	SPQ	Reel Diameter (mm)	Reel Width W1 (mm)	A0 (mm)	B0 (mm)	K0 (mm)	P1 (mm)	W (mm)	Pin1 Quadrant
DS26LV32ATMX/NOPB	SOIC	D	16	2500	330.0	16.4	6.5	10.3	2.3	8.0	16.0	Q1

TAPE AND REEL BOX DIMENSIONS

*All dimensions are nominal

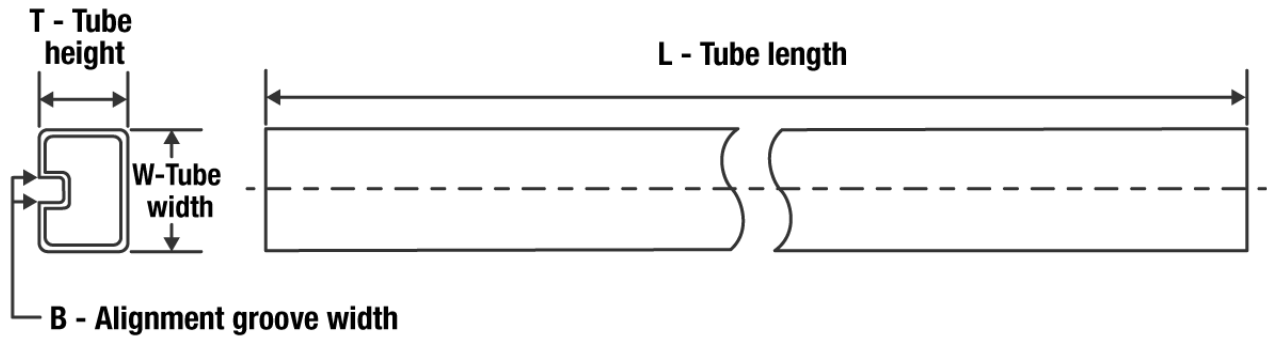
Device	Package Type	Package Drawing	Pins	SPQ	Length (mm)	Width (mm)	Height (mm)
DS26LV32ATMX/NOPB	SOIC	D	16	2500	853.0	449.0	35.0

TUBE

*All dimensions are nominal

Device	Package Name	Package Type	Pins	SPQ	L (mm)	W (mm)	T (μm)	B (mm)
DS26LV32ATM/NOPB	D	SOIC	16	48	495	8	4064	3.05

D (R-PDSO-G16)

PLASTIC SMALL OUTLINE



- NOTES:
- A. All linear dimensions are in inches (millimeters).
 - B. This drawing is subject to change without notice.
 - C. Body length does not include mold flash, protrusions, or gate burrs. Mold flash, protrusions, or gate burrs shall not exceed 0.006 (0,15) each side.
 - D. Body width does not include interlead flash. Interlead flash shall not exceed 0.017 (0,43) each side.
 - E. Reference JEDEC MS-012 variation AC.

IMPORTANT NOTICE AND DISCLAIMER

TI PROVIDES TECHNICAL AND RELIABILITY DATA (INCLUDING DATA SHEETS), DESIGN RESOURCES (INCLUDING REFERENCE DESIGNS), APPLICATION OR OTHER DESIGN ADVICE, WEB TOOLS, SAFETY INFORMATION, AND OTHER RESOURCES "AS IS" AND WITH ALL FAULTS, AND DISCLAIMS ALL WARRANTIES, EXPRESS AND IMPLIED, INCLUDING WITHOUT LIMITATION ANY IMPLIED WARRANTIES OF MERCHANTABILITY, FITNESS FOR A PARTICULAR PURPOSE OR NON-INFRINGEMENT OF THIRD PARTY INTELLECTUAL PROPERTY RIGHTS.

These resources are intended for skilled developers designing with TI products. You are solely responsible for (1) selecting the appropriate TI products for your application, (2) designing, validating and testing your application, and (3) ensuring your application meets applicable standards, and any other safety, security, regulatory or other requirements.

These resources are subject to change without notice. TI grants you permission to use these resources only for development of an application that uses the TI products described in the resource. Other reproduction and display of these resources is prohibited. No license is granted to any other TI intellectual property right or to any third party intellectual property right. TI disclaims responsibility for, and you will fully indemnify TI and its representatives against, any claims, damages, costs, losses, and liabilities arising out of your use of these resources.

TI's products are provided subject to [TI's Terms of Sale](#) or other applicable terms available either on ti.com or provided in conjunction with such TI products. TI's provision of these resources does not expand or otherwise alter TI's applicable warranties or warranty disclaimers for TI products.

TI objects to and rejects any additional or different terms you may have proposed.

Mailing Address: Texas Instruments, Post Office Box 655303, Dallas, Texas 75265
Copyright © 2022, Texas Instruments Incorporated