

## DRV8880 具有 AutoTune™ 功能的 2A 步进电机驱动器

### 1 特性

- 微步进电机驱动器
  - STEP/DIR 接口
  - 最高 1/16 的微步进分度器
  - 非循环和标准 1/2 步进模式
- 6.5V 至 45V 的工作电源电压范围
- 多种衰减模式，可为任何电机提供支持
  - AutoTune™
  - 混合衰减
  - 慢速衰减
  - 快速衰减
- 平滑步进的自适应消隐时间
- 可配置关断时间脉宽调制 (PWM) 斩波
  - 10、20 或 30μs 关断时间
- 3.3V, 10mA 低压降 (LDO) 稳压器
- 低电流休眠模式 (28μA)
- 小型封装尺寸
  - 28 HTSSOP (PowerPAD™)
  - 28 WQFN
- 保护 特性
  - VM 欠压锁定 (UVLO2)
  - 逻辑欠压 (UVLO1)
  - 电荷泵电压 (CPUV)
  - 过流保护 (OCP)
    - 锁存过流保护 (OCP) 模式
    - 重试过流保护 (OCP) 模式
  - 热关断 (TSD)
  - 故障条件指示引脚 (nFAULT)

### 2 应用

- 自动取款机和验钞机
- 视频安保摄像机
- 多功能打印机和文档扫描仪
- 3D 打印机
- 办公自动化设备
- 工厂自动化和机器人

### 3 说明

DRV8880 是一款适用于工业应用的双极步进电机驱动器。该器件具有两个 N 沟道功率金属氧化物半导体场效应晶体管 (MOSFET) H 桥驱动器和一个微步进分度器。DRV8880 能够驱动高达 2.0A 的满量程电流或 1.4A 均方根 (rms) 电流 (采用适当的印刷电路板 (PCB) 接地层进行散热, 电压为 24V,  $T_A = 25^\circ\text{C}$ )。

AutoTune™ 可自动调整步进电机以实现最佳电流调节性能, 并且能够对电机变化和老化问题进行补偿。此外, 该器件还提供慢速、快速和混合三种衰减模式。

STEP/DIR 引脚提供简单的控制接口。器件可配置为多种步进模式, 从全步进模式到 1/16 步进模式。凭借专用的 nSLEEP 引脚, 该器件可提供一种低功耗的休眠模式, 从而实现超低静态电流待机。

该器件内置以下保护功能: 欠压、电荷泵故障、过流、短路以及过热保护。故障条件通过 nFAULT 引脚指示。

#### 器件信息<sup>(1)</sup>

器件型号	封装	封装尺寸 (标称值)
DRV8880	HTSSOP (28)	9.70mm x 4.40mm
	WQFN (28)	5.50mm x 3.50mm

(1) 如需了解所有可用封装, 请参阅数据表末尾的可订购产品附录。

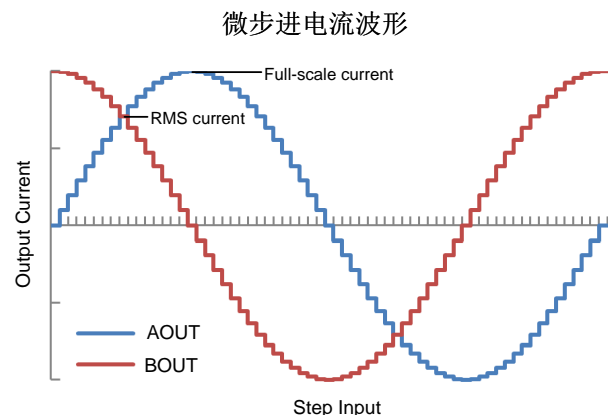
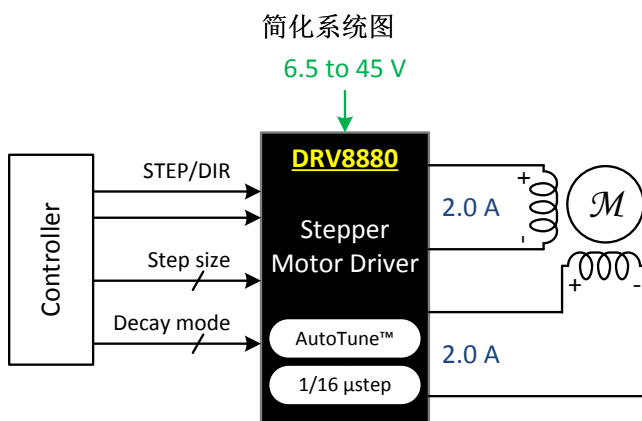

## 目录

<b>1</b>	特性 .....	<b>1</b>	7.4	Device Functional Modes .....	<b>30</b>
<b>2</b>	应用 .....	<b>1</b>	<b>8</b>	<b>Application and Implementation</b> .....	<b>31</b>
<b>3</b>	说明 .....	<b>1</b>	8.1	Application Information .....	<b>31</b>
<b>4</b>	修订历史记录 .....	<b>2</b>	8.2	Typical Application .....	<b>31</b>
<b>5</b>	<b>Pin Configuration and Functions</b> .....	<b>3</b>	<b>9</b>	<b>Power Supply Recommendations</b> .....	<b>35</b>
<b>6</b>	<b>Specifications</b> .....	<b>5</b>	9.1	Bulk Capacitance Sizing .....	<b>35</b>
6.1	Absolute Maximum Ratings .....	<b>5</b>	<b>10</b>	<b>Layout</b> .....	<b>36</b>
6.2	ESD Ratings .....	<b>5</b>	10.1	Layout Guidelines .....	<b>36</b>
6.3	Recommended Operating Conditions .....	<b>5</b>	10.2	Layout Example .....	<b>36</b>
6.4	Thermal Information .....	<b>6</b>	<b>11</b>	<b>器件和文档支持</b> .....	<b>37</b>
6.5	Electrical Characteristics .....	<b>6</b>	11.1	文档支持 .....	<b>37</b>
6.6	Indexer Timing Requirements .....	<b>8</b>	11.2	接收文档更新通知 .....	<b>37</b>
6.7	Typical Characteristics .....	<b>9</b>	11.3	社区资源 .....	<b>37</b>
<b>7</b>	<b>Detailed Description</b> .....	<b>11</b>	11.4	商标 .....	<b>37</b>
7.1	Overview .....	<b>11</b>	11.5	静电放电警告 .....	<b>37</b>
7.2	Functional Block Diagram .....	<b>12</b>	11.6	Glossary .....	<b>37</b>
7.3	Feature Description .....	<b>13</b>	<b>12</b>	<b>机械、封装和可订购信息</b> .....	<b>37</b>

## 4 修订历史记录

注：之前版本的页码可能与当前版本有所不同。

<b>Changes from Revision B (August 2017) to Revision C</b>	<b>Page</b>
• Changed the maximum value for VREF from V3P3 + 0.5 V to 4.1 V in the <i>Absolute Maximum Ratings</i> table .....	<b>5</b>

  

<b>Changes from Revision A (July 2015) to Revision B</b>	<b>Page</b>
• Added the <i>Power Supplies and Input Pins</i> section .....	<b>27</b>
• 已添加 接收文档更新通知部分 .....	<b>37</b>

<b>Changes from Original (June 2015) to Revision A</b>	<b>Page</b>
• 已将器件状态更新为量产数据 .....	<b>1</b>
• Updated from "PowerPAD" to "thermal pad" .....	<b>4</b>

## 5 Pin Configuration and Functions

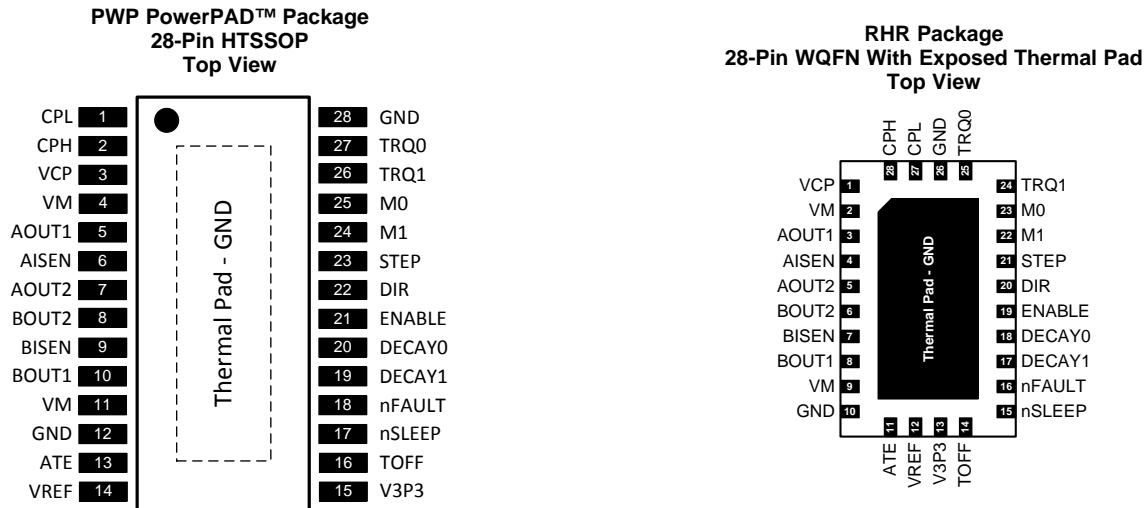

### Pin Functions

PIN			TYPE	DESCRIPTION	
NAME	PWP	RHR			
CPL	1	27	PWR	Charge pump switching pins	Connect a VM rated, 0.1- $\mu$ F ceramic capacitor between CPH and CPL
CPH	2	28			
VCP	3	1	O	Charge pump output	Connect a 16 V, 0.47 $\mu$ F ceramic capacitor to VM
VM	4, 11	2, 9	PWR	Power supply	Connect to motor supply voltage; bypass to GND with two 0.1 $\mu$ F (for each pin) plus one bulk capacitor rated for VM
AOUT1	5	3	O	Winding A output	H-bridge outputs, drives one winding of a stepper motor
AOUT2	7	5			
AISEN	6	4	O	Winding A sense	Requires sense resistor to GND; value sets peak current in winding A
BOUT2	8	6	O	Winding B output	H-bridge outputs, drives one winding of a stepper motor
BOUT1	10	8			
BISEN	9	7	O	Winding B sense	Requires sense resistor to GND; value sets peak current in winding B
GND	12, 28	10, 26	PWR	Device ground	Must be connected to ground
ATE	13	11	I	AutoTune enable pin	Logic high enables AutoTune operation; when logic low, the decay mode is set through the DECAy pins; AutoTune must be pulled high prior to power-up or coming out of sleep, or else tied to V3P3 in order to enable AutoTune; internal pulldown; see <a href="#">AutoTune</a>
VREF	14	12	I	Full scale current reference input	Voltage on this pin sets the full scale chopping current.
V3P3	15	13	PWR	Internal regulator	Internal supply voltage; bypass to GND with a 6.3 V, 0.47 $\mu$ F ceramic capacitor; up to 10 mA external load
TOFF	16	14	I	Decay mode off time set	Sets the off-time during current chopping; tri-level pin
nSLEEP	17	15	I	Sleep mode input	Logic high to enable device; logic low to enter low-power sleep mode; internal pulldown
nFAULT	18	16	O	Fault indication pin	Pulled logic low with fault condition; open-drain output requires an external pullup
DECAy1	19	17	I	Decay mode setting pins	Sets the decay mode; see description section; tri-level pin
DECAy0	20	18			
ENABLE	21	19	I	Enable driver input	Logic high to enable device outputs and internal indexer; logic low to disable; internal pulldown
DIR	22	20	I	Direction input	Logic level sets the direction of stepping; internal pulldown

**Pin Functions (continued)**

PIN			TYPE	DESCRIPTION	
NAME	PWP	RHR			
STEP	23	21	I	Step input	A rising edge causes the indexer to advance one step; internal pulldown
M1	24	22	I	Microstepping mode setting pins	Sets the step mode; full, 1/2, 1/4, 1/8, 1/16; tri-level pin
M0	25	23			
TRQ1	26	24	I	Torque DAC current scalar	Scales the current by 100%, 75%, 50%, or 25%; internal pulldown
TRQ0	27	25			
PAD	PAD	PAD	PWR	Thermal pad	Must be connected to ground

## 6 Specifications

### 6.1 Absolute Maximum Ratings

over operating free-air temperature range referenced with respect to GND (unless otherwise noted) <sup>(1)</sup>

	MIN	MAX	UNIT
Power supply voltage (VM)	-0.3	50	V
Power supply voltage ramp rate (VM)	0	2	V/μs
Charge pump voltage (VCP, CPH)	-0.3	VM + 12	V
Charge pump negative switching pin (CPL)	-0.3	VM	V
Internal regulator voltage (V3P3)	-0.3	3.8	V
Internal regulator current output (V3P3)	0	10	mA
Control pin voltage (STEP, DIR, ENABLE, nSLEEP, nFAULT, M0, M1, DECAY0, DECAY1, TRQ0, TRQ1, ATE)	-0.3	7.0	V
Open drain output current (nFAULT)	0	10	mA
Reference input pin voltage (VREF)	-0.3	4.1	V
Continuous phase node pin voltage (AOUT1, AOUT2, BOUT1, BOUT2)	-0.7	VM + 0.7	V
Continuous shunt amplifier input pin voltage (AISEN, BISEN) <sup>(2)</sup>	-0.55	0.55	V
Peak drive current (AOUT1, AOUT2, BOUT1, BOUT2, AISEN, BISEN)	Internally limited		A
Operating junction temperature, T <sub>J</sub>	-40	150	°C
Storage temperature, T <sub>stg</sub>	-65	150	°C

(1) Stresses beyond those listed under *Absolute Maximum Ratings* may cause permanent damage to the device. These are stress ratings only, which do not imply functional operation of the device at these or any other conditions beyond those indicated under *Recommended Operating Conditions*. Exposure to absolute-maximum-rated conditions for extended periods may affect device reliability.

(2) Transients of ±1 V for less than 25 ns are acceptable

### 6.2 ESD Ratings

		VALUE	UNIT
V <sub>(ESD)</sub>	Electrostatic discharge	Human-body model (HBM), per ANSI/ESDA/JEDEC JS-001 <sup>(1)</sup>	±4000
		Charged-device model (CDM), per JEDEC specification JESD22-C101 <sup>(2)</sup>	±1000

(1) JEDEC document JEP155 states that 500-V HBM allows safe manufacturing with a standard ESD control process.

(2) JEDEC document JEP157 states that 250-V CDM allows safe manufacturing with a standard ESD control process.

### 6.3 Recommended Operating Conditions

		MIN	MAX	UNIT
VM	Power supply voltage range	6.5 <sup>(1)</sup>	45	V
V <sub>IN</sub>	Digital pin voltage range	0	5.3	V
VREF	Reference rms voltage range	0.3 <sup>(2)</sup>	V3P3	V
f <sub>PWM</sub>	Applied STEP signal	0	100 <sup>(3)</sup>	kHz
I <sub>V3P3</sub>	V3P3 external load current	0	10 <sup>(4)</sup>	mA
I <sub>FS</sub>	Motor full scale current	0	2.0	A
I <sub>rms</sub>	Motor rms current	0	1.4	A
T <sub>A</sub>	Operating ambient temperature	-40	125	°C

(1) Internal logic and indexer remain active down to V<sub>UVLO2</sub> (4.9 V maximum) even though the output H-bridges are disabled

(2) Operational at VREF ≈ 0 to 0.3 V, but accuracy is degraded

(3) STEP input can operate up to 1 MHz, but system bandwidth is limited by the motor load

(4) Power dissipation and thermal limits must be observed

## 6.4 Thermal Information

THERMAL METRIC <sup>(1)</sup>		DRV8880		UNIT
		PWP (HTSSOP)	RHR (WQFN)	
		28 PINS	28 PINS	
R <sub>θJA</sub>	Junction-to-ambient thermal resistance	33.1	37.5	°C/W
R <sub>θJC(top)</sub>	Junction-to-case (top) thermal resistance	16.6	23.0	°C/W
R <sub>θJB</sub>	Junction-to-board thermal resistance	14.4	8.0	°C/W
ψ <sub>JT</sub>	Junction-to-top characterization parameter	0.4	0.2	°C/W
ψ <sub>JB</sub>	Junction-to-board characterization parameter	14.2	7.8	°C/W
R <sub>θJC(bot)</sub>	Junction-to-case (bottom) thermal resistance	1.3	1.7	°C/W

(1) For more information about traditional and new thermal metrics, see the [Semiconductor and IC Package Thermal Metrics application report](#).

## 6.5 Electrical Characteristics

over operating free-air temperature range (unless otherwise noted)

PARAMETER		TEST CONDITIONS	MIN	TYP	MAX	UNIT
<b>POWER SUPPLIES (VM, V3P3)</b>						
VM	VM operating voltage		6.5		45	V
I <sub>VM</sub>	VM operating supply current	nSLEEP high; ENABLE high; no motor load; VM = 24 V		8	18	mA
I <sub>VMQ</sub>	VM sleep mode supply current	nSLEEP low; VM = 24 V; T <sub>A</sub> = 25°C		28		μA
		nSLEEP low; VM = 24 V; T <sub>A</sub> = 125°C <sup>(1)</sup>			77	
t <sub>SLEEP</sub>	Sleep time	nSLEEP low to sleep mode			100	μs
t <sub>WAKE</sub>	Wake-up time	nSLEEP high to output transition			1.5	ms
t <sub>ON</sub>	Turn-on time	VM > V <sub>UVLO2</sub> to output transition			1.5	ms
V3P3	LDO regulator voltage	External load 0 to 10 mA	2.9	3.3	3.6	V
<b>CHARGE PUMP (VCP, CPH, CPL)</b>						
V <sub>CP</sub>	VCP operating voltage	VM > 12 V		VM + 11.5		V
		V <sub>UVLO2</sub> < VM < 12 V		2xVM – 1.5		
f <sub>VCP</sub> <sup>(1)</sup>	Charge pump switching frequency	VM > V <sub>UVLO2</sub>	175		715	kHz
<b>LOGIC-LEVEL INPUTS (STEP, DIR, ENABLE, nSLEEP, TRQ0, TRQ1, ATE)</b>						
V <sub>IL</sub>	Input logic low voltage		0		0.6	V
V <sub>IH</sub>	Input logic high voltage		1.6		5.3	V
V <sub>HYS</sub>	Input logic hysteresis		100			mV
I <sub>IL</sub>	Input logic low current	V <sub>IN</sub> = 0 V	-1		1	μA
I <sub>IH</sub>	Input logic high current	V <sub>IN</sub> = 5.0 V		50	100	μA
R <sub>PD</sub>	Pulldown resistance	Measured between the pin and GND		100		kΩ
t <sub>PD</sub>	Propagation delay	STEP input to current change		450		ns
<b>TRI-LEVEL INPUTS (M0, M1, DECAY0, DECAY1, TOFF)</b>						
V <sub>IL</sub>	Tri-level input logic low voltage		0		0.6	V
V <sub>IZ</sub>	Tri-level input Hi-Z voltage			1.1		V
V <sub>IH</sub>	Tri-level input logic high voltage		1.6		5.3	V
V <sub>HYS</sub>	Tri-level input hysteresis		100			mV
I <sub>IL</sub>	Tri-level input logic low current	V <sub>IN</sub> = 0 V	-55		-35	μA
I <sub>IZ</sub>	Tri-level input Hi-Z current	V <sub>IN</sub> = 1.3 V		15		μA
I <sub>IH</sub>	Tri-level input logic high current	V <sub>IN</sub> = 3.3 V		85		μA
R <sub>PD</sub>	Tri-level pulldown resistance	Measured between the pin and GND		40		kΩ
R <sub>PU</sub>	Tri-level pullup resistance	Measured between V3P3 and the pin		45		kΩ

(1) Specified by design and characterization data

## Electrical Characteristics (continued)

over operating free-air temperature range (unless otherwise noted)

PARAMETER		TEST CONDITIONS	MIN	TYP	MAX	UNIT
<b>CONTROL OUTPUTS (nFAULT)</b>						
$V_{OL}$	Output logic low voltage	$I_O = 4\text{ mA}$			0.5	V
$I_{OH}$	Output logic high leakage	External pullup resistor to 3.3 V	-1		1	$\mu\text{A}$
<b>MOTOR DRIVER OUTPUTS (AOUT1, AOUT2, BOUT1, BOUT2)</b>						
$R_{DS(ON)}$	High-side FET on resistance	VM = 24 V, I = 1 A, $T_A = 25^\circ\text{C}$		330		m $\Omega$
		VM = 24 V, I = 1 A, $T_A = 125^\circ\text{C}$ <sup>(1)</sup>		400	440	
		VM = 6.5 V, I = 1 A, $T_A = 25^\circ\text{C}$		430		
		VM = 6.5 V, I = 1 A, $T_A = 125^\circ\text{C}$ <sup>(1)</sup>		500	560	
$R_{DS(ON)}$	Low-side FET on resistance	VM = 24 V, I = 1 A, $T_A = 25^\circ\text{C}$		300		m $\Omega$
		VM = 24 V, I = 1 A, $T_A = 125^\circ\text{C}$ <sup>(1)</sup>		370	400	
		VM = 6.5 V, I = 1 A, $T_A = 25^\circ\text{C}$		370		
		VM = 6.5 V, I = 1 A, $T_A = 125^\circ\text{C}$ <sup>(1)</sup>		450	490	
$t_{RISE}$	Output rise time	VM = 24 V, 50 $\Omega$ load from xOUTx to GND		70		ns
$t_{FALL}$	Output fall time	VM = 24 V, 50 $\Omega$ load from VM to xOUTx		70		ns
$t_{DEAD}$	Output dead time <sup>(2)</sup>			200		ns
$V_d$	Body diode forward voltage	$I_{OUT} = 0.5\text{ A}$		0.7	1	V
<b>PWM CURRENT CONTROL (VREF, AISEN, BISEN)</b>						
$V_{TRIP}$	xISENSE trip voltage, full scale	TRQ at 100%, VREF = 3.3 V		500		mV
		TRQ at 75%, VREF = 3.3 V		375		
		TRQ at 50%, VREF = 3.3 V		250		
		TRQ at 25%, VREF = 3.3 V		125		
$A_V$	Amplifier attenuation	TRQ at 100% (TRQ0 = 0, TRQ1 = 0)	6.25	6.58	6.91	V/V
		TRQ at 75% (TRQ0 = 1, TRQ1 = 0)	6.2	6.56	6.92	
		TRQ at 50% (TRQ0 = 0, TRQ1 = 1)	6.09	6.51	6.94	
		TRQ at 25% (TRQ0 = 1, TRQ1 = 1)	5.83	6.38	6.93	
$t_{OFF}$	PWM off-time	TOFF Logic Low		20		$\mu\text{s}$
		TOFF Logic High		30		
		TOFF Hi-Z		10		
$t_{BLANK}$	PWM blanking time	See <a href="#">Table 9</a> for details		1.8		$\mu\text{s}$
				1.5		
				1.2		
				0.9		
<b>PROTECTION CIRCUITS</b>						
$V_{UVLO2}$	VM undervoltage lockout	VM falling; UVLO2 report		5.8	6.4	V
		VM rising; UVLO2 recovery		6.1	6.5	
$V_{UVLO1}$	Logic undervoltage	VM falling; logic disabled		4.5	4.9	V
		VM rising; logic enabled		4.8	5	
$V_{UVLO,HYS}$	undervoltage hysteresis	Rising to falling threshold	100			mV
$V_{CPUV}$	Charge pump undervoltage	VCP falling; CPUV report		VM + 1.8		V
		VCP rising; CPUV recovery		VM + 1.9		
$V_{CPUV,HYS}$	CP undervoltage hysteresis	Rising to falling threshold	50			mV
$I_{OCP}$	Overcurrent protection trip level	Current through any FET	2.5	3.6		A
$V_{OCP}$	Sense pin overcurrent trip level	Voltage at AISEN or BISEN	0.9	1.25		V
$t_{OCP}$	Overcurrent deglitch time			2		$\mu\text{s}$

(2) Specified by design and characterization data

## Electrical Characteristics (continued)

over operating free-air temperature range (unless otherwise noted)

PARAMETER	TEST CONDITIONS	MIN	TYP	MAX	UNIT
$t_{\text{RETRY}}$	Overcurrent retry time	0.5		2	ms
$T_{\text{TSD}}^{(2)}$	Thermal shutdown temperature	Die temperature $T_J$	150		°C
$T_{\text{HYS}}^{(2)}$	Thermal shutdown hysteresis	Die temperature $T_J$	35		°C

## 6.6 Indexer Timing Requirements

NO.		MIN	MAX	UNIT
1	$f_{\text{STEP}}$ Step frequency		1 <sup>(1)</sup>	MHz
2	$t_{\text{WH}}(\text{STEP})$ Pulse duration, STEP high	470		ns
3	$t_{\text{WL}}(\text{STEP})$ Pulse duration, STEP low	470		ns
4	$t_{\text{SU}}(\text{DIR, Mx})$ Setup time, DIR or Mx to STEP rising	200		ns
5	$t_{\text{H}}(\text{DIR, Mx})$ Hold time, DIR or Mx to STEP rising	200		ns

(1) STEP input can operate up to 1 MHz, but system bandwidth is limited by the motor load

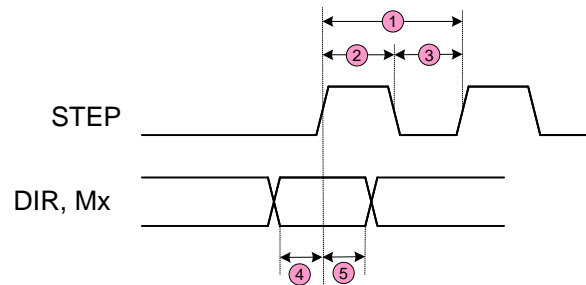

**Figure 1. Timing Diagram**

## 6.7 Typical Characteristics

Over recommended operating conditions (unless otherwise noted)

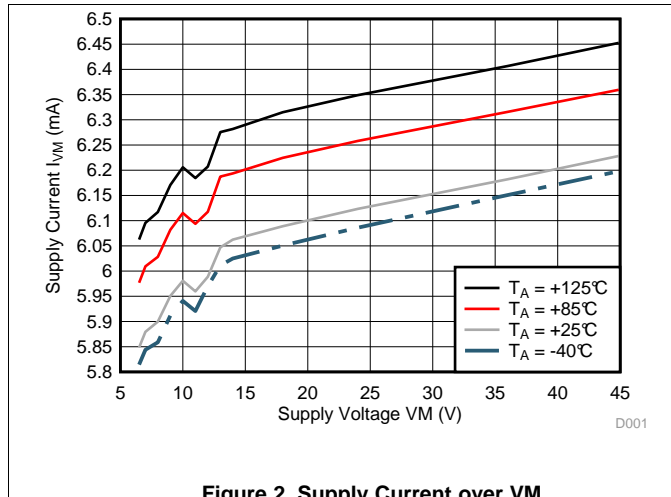

Figure 2. Supply Current over VM

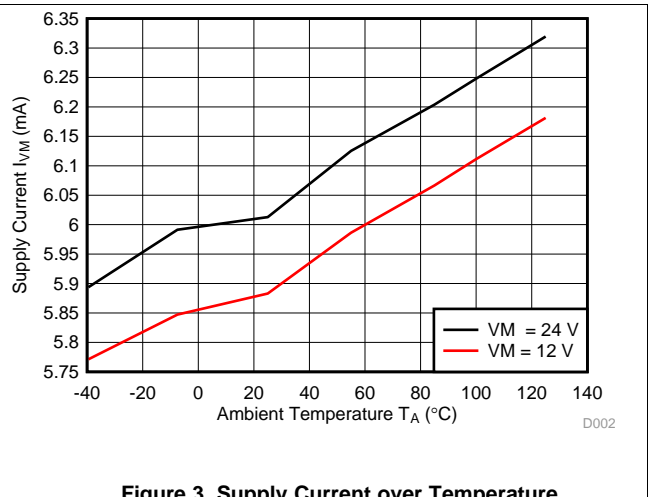

Figure 3. Supply Current over Temperature

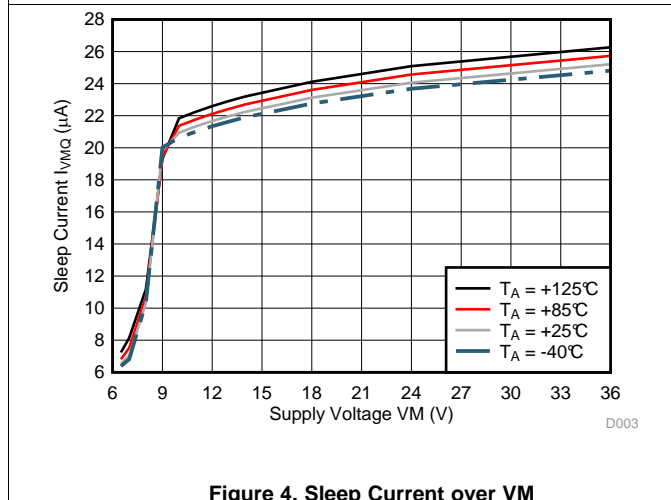

Figure 4. Sleep Current over VM

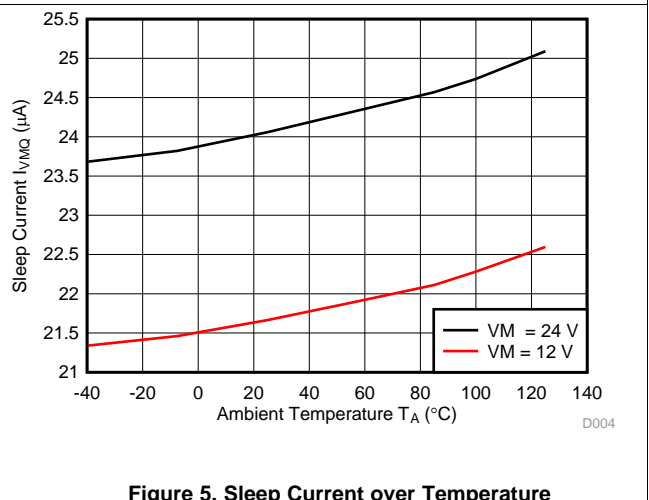

Figure 5. Sleep Current over Temperature

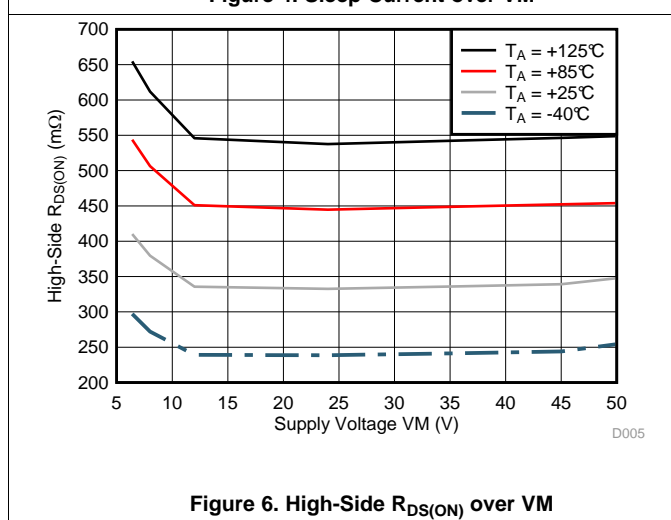

Figure 6. High-Side  $R_{DS(ON)}$  over VM

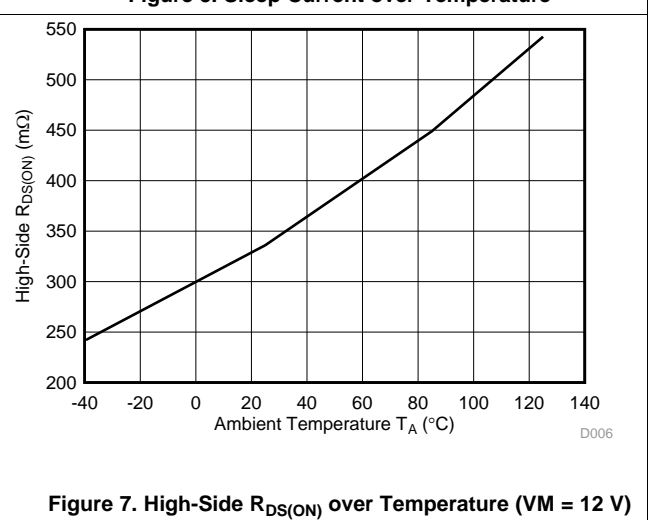
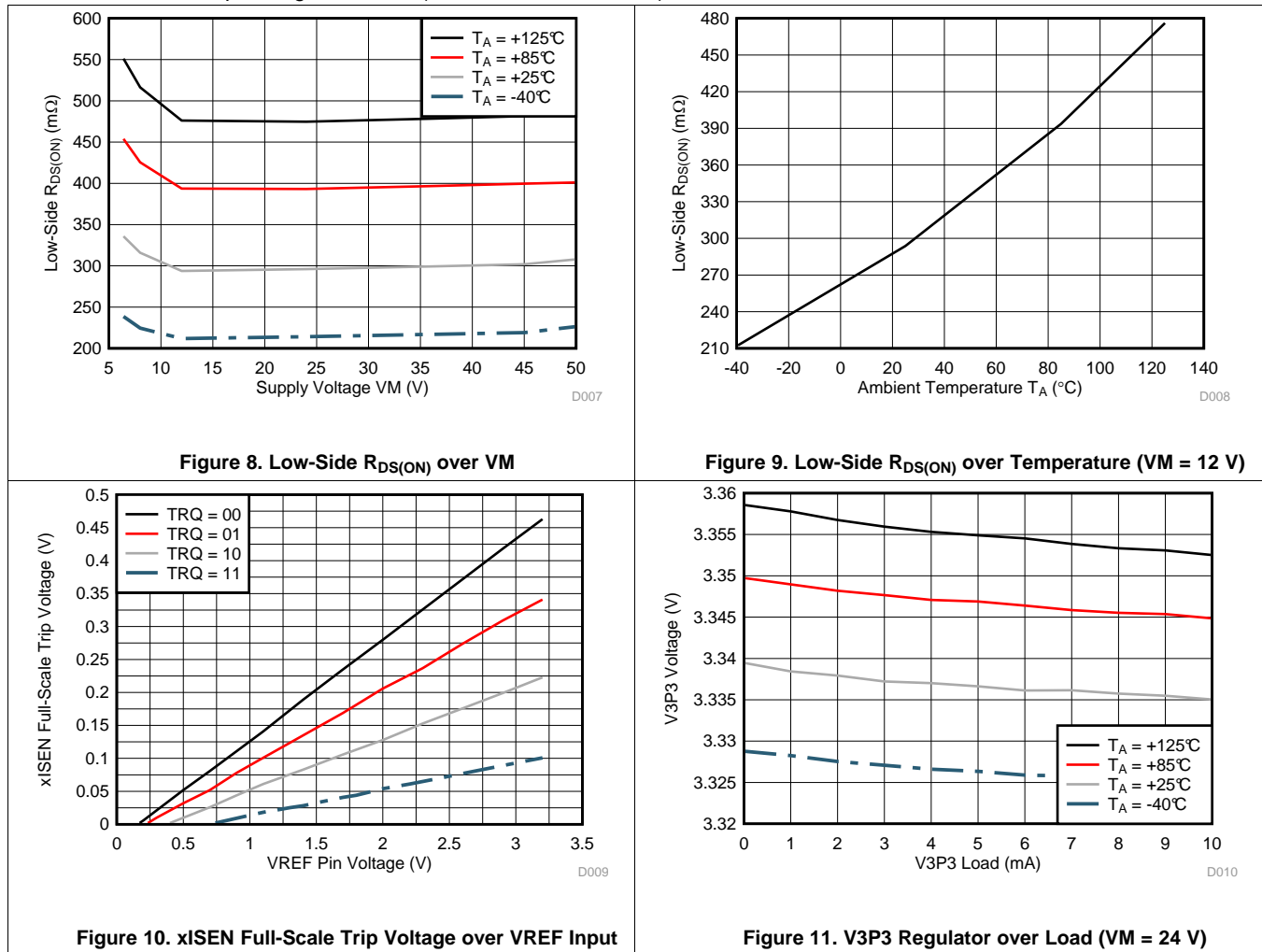

Figure 7. High-Side  $R_{DS(ON)}$  over Temperature ( $V_M = 12\text{ V}$ )

### Typical Characteristics (continued)

Over recommended operating conditions (unless otherwise noted)



## 7 Detailed Description

### 7.1 Overview

The DRV8880 is an integrated motor driver solution for bipolar stepper motors. The device integrates two NMOS H-bridges, current regulation circuitry, and a microstepping indexer. The DRV8880 can be powered with a supply voltage between 6.5 and 45 V, and is capable of providing an output current up to 2.5 A peak current, 2.0 A full-scale current, or 1.4 A rms current. Actual operable full-scale and rms current will depend on ambient temperature, supply voltage, and PCB ground plane size. Between  $V_M = 6.4$  V and  $V_M = 4.9$  V the H-bridge outputs are shut down, but the internal logic remains active in order to prevent missed steps.

A simple STEP/DIR interface allows easy interfacing to the controller circuit. The internal indexer is able to execute high-accuracy microstepping without requiring the processor to control the current level. The indexer is capable of full step and half step as well as microstepping to 1/4, 1/8, and 1/16. In addition to the standard half stepping mode, a non-circular 1/2-stepping mode is available for increased torque output at higher motor rpm.

The current regulation is highly configurable, with several decay modes of operation. The decay mode can be selected as a fixed slow, slow/mixed, mixed, slow/fast, or fast decay. The slow/mixed decay mode uses slow decay on increasing steps and mixed decay on decreasing steps. Similarly, the slow/fast decay mode uses slow decay on increasing steps and fast decay on decreasing steps.

In addition, an AutoTune mode can be used which automatically adjusts the decay setting to minimize current ripple while still reacting quickly to step changes. This feature greatly simplifies stepper driver integration into a motor drive system.

The PWM off-time,  $t_{OFF}$ , can be adjusted to 10, 20, or 30  $\mu$ s.

An adaptive blanking time feature automatically scales the minimum drive time with output current. This helps alleviate zero-crossing distortion by limiting the drive time at low-current steps.

A torque DAC feature allows the controller to scale the output current without needing to scale the analog reference voltage input VREF. The torque DAC is accessed using digital input pins. This allows the controller to save power by decreasing the current consumption when not required.

A low-power sleep mode is included which allows the system to save power when not driving the motor.

## 7.2 Functional Block Diagram

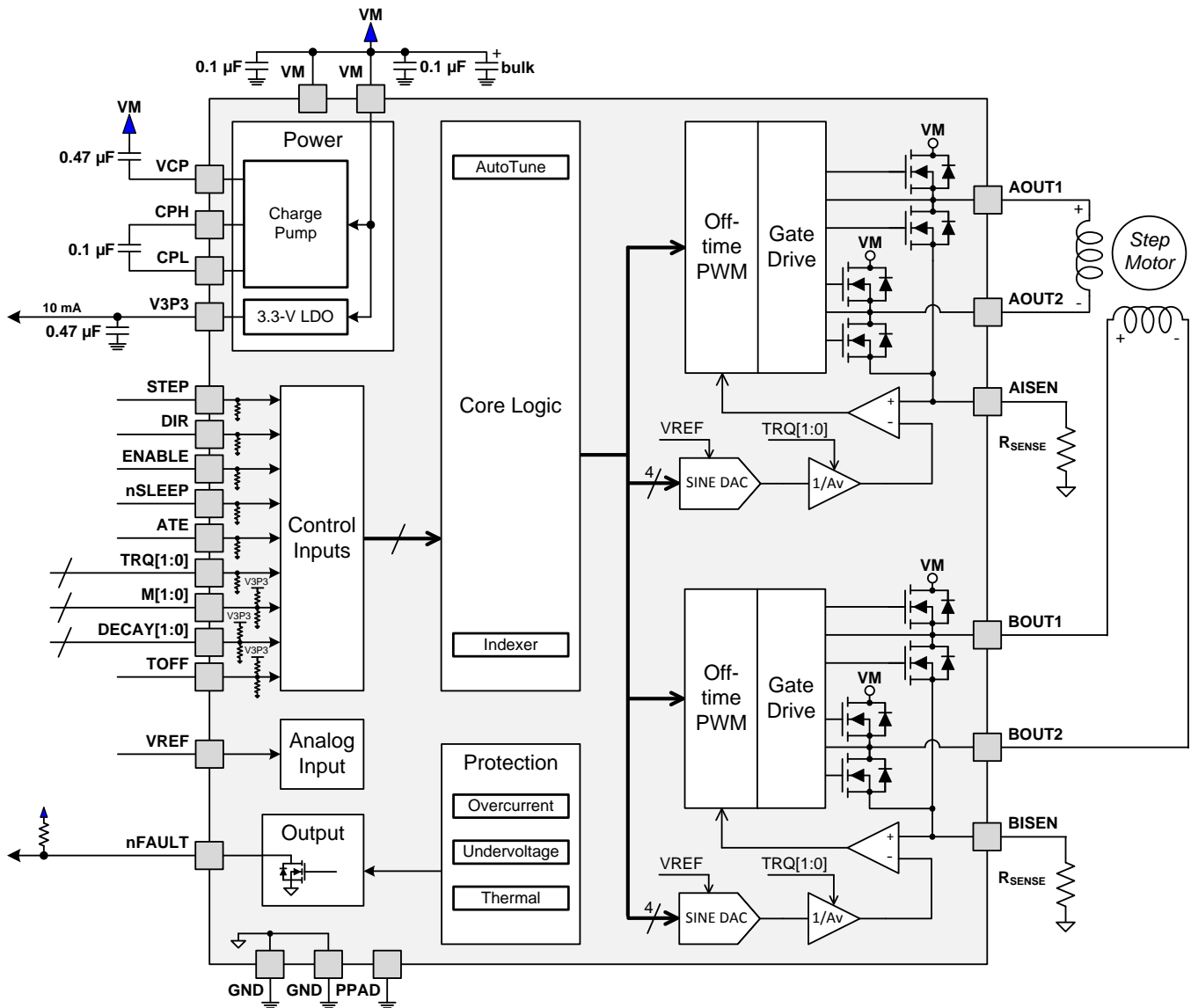

### 7.3 Feature Description

Table 1 lists the recommended values of the external components.

Table 1. External Components

COMPONENT	PIN 1	PIN 2	RECOMMENDED
C <sub>VM1</sub>	VM	GND	0.1-μF ceramic capacitor rated for VM per VM pin
C <sub>VM1</sub>	VM	GND	Bulk electrolytic capacitor rated for VM, recommended value is 100 μF, see <a href="#">Bulk Capacitance Sizing</a>
C <sub>VCP</sub>	VCP	VM	16-V, 0.47-μF ceramic capacitor
C <sub>SW</sub>	CPH	CPL	0.1-μF X7R capacitor rated for VM
C <sub>V3P3</sub>	V3P3	GND	6.3-V, 0.47-μF ceramic capacitor
R <sub>nFAULT</sub>	V <sub>MCU</sub> <sup>(1)</sup>	nFAULT	> 5 kΩ pullup
R <sub>AISEN</sub>	AISEN	GND	Sense resistor, see <a href="#">Sense Resistor</a>
R <sub>BISEN</sub>	BISEN	GND	

(1) V<sub>MCU</sub> is not a pin on the DRV8880, but a supply voltage pullup is required for open-drain output nFAULT; nFAULT may be pulled up to V3P3

#### 7.3.1 Stepper Motor Driver Current Ratings

Stepper motor drivers can be classified using three different numbers to describe the output current: peak, rms, and full-scale.

##### 7.3.1.1 Peak Current Rating

The peak current in a stepper driver is limited by the overcurrent protection trip threshold I<sub>OCP</sub>. The peak current describes any transient duration current pulse, for example when charging capacitance, when the overall duty cycle is very low. In general the minimum value of I<sub>OCP</sub> specifies the peak current rating of the stepper motor driver. For the DRV8880, the peak current rating is 2.5 A per bridge.

##### 7.3.1.2 RMS Current Rating

The rms (average) current is determined by the thermal considerations of the IC. The rms current is calculated based on the R<sub>DS(ON)</sub>, rise and fall time, PWM frequency, device quiescent current, and package thermal performance in a typical system at 25°C. The real operating rms current may be higher or lower depending on heatsinking and ambient temperature. For the DRV8880, the rms current rating is 1.4 A per bridge.

##### 7.3.1.3 Full-Scale Current Rating

The full-scale current describes the top of the sinusoid current waveform while microstepping. Since the sinusoid amplitude is related to the rms current, the full-scale current is also determined by the thermal considerations of the IC. The full-scale current rating is approximately  $\sqrt{2} \times I_{rms}$ . The full-scale current is set by VREF, the sense resistor, and Torque DAC when configuring the DRV8880, see [Current Regulation](#) for details. For the DRV8880, the full-scale current rating is 2.0 A per bridge.

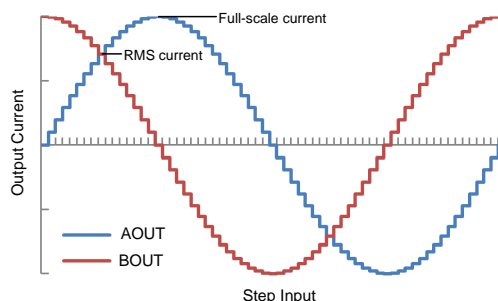

Figure 12. Full-Scale and rms Current

### 7.3.2 PWM Motor Drivers

The DRV8880 contains drivers for two full H-bridges. A block diagram of the circuitry is shown in Figure 13.

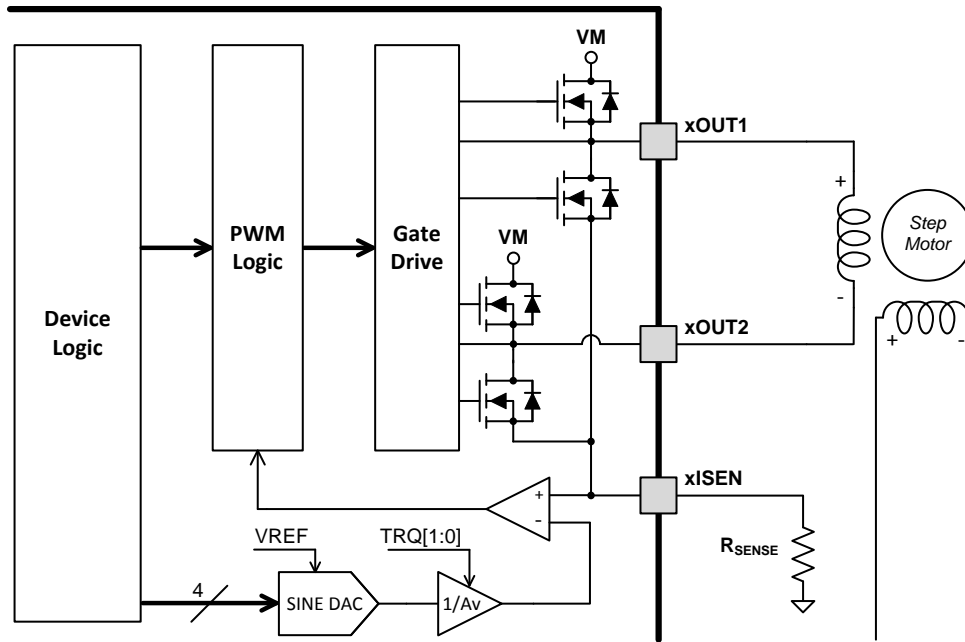

Figure 13. PWM Motor Driver Block Diagram

### 7.3.3 Microstepping Indexer

Built-in indexer logic in the DRV8880 allows a number of different stepping configurations. The Mx pins are used to configure the stepping format as shown in Table 2.

Table 2. Microstepping Settings

M1	M0	STEP MODE
0	0	Full step (2-phase excitation) with 71% current
0	1	Non-circular 1/2 step
1	0	1/2 step
1	1	1/4 step
0	Z	1/8 step
1	Z	1/16 step
Z	0	Reserved
Z	1	Reserved
Z	Z	Reserved

Table 3 shows the relative current and step directions for full-step through 1/16-step operation. The AOUT current is the sine of the electrical angle; BOUT current is the cosine of the electrical angle. Positive current is defined as current flowing from xOUT1 to xOUT2 while driving.

At each rising edge of the STEP input the indexer travels to the next state in the table. The direction is shown with the DIR pin logic high. If the DIR pin is logic low, the sequence is reversed.

Note that if the step mode is changed while stepping, the indexer will advance to the next valid state for the new MODE setting at the rising edge of STEP.

The home state is an electrical angle of 45°. This state is entered after power-up, after exiting logic undervoltage lockout, or after exiting sleep mode. This is shown in Table 3 with the highlighted row.

**Table 3. Microstepping Relative Current Per Step**

FULL STEP	1/2 STEP	1/4 STEP	1/8 STEP	1/16 STEP	ELECTRICAL ANGLE (°)	AOUT CURRENT (% full-scale)	BOUT CURRENT (% full-scale)
	1	1	1	1	0.000°	0%	100%
				2	5.625°	10%	100%
			2	3	11.250°	20%	98%
				4	16.875°	29%	96%
		2	3	5	22.500°	38%	92%
				6	28.125°	47%	88%
			4	7	33.750°	56%	83%
				8	39.375°	63%	77%
1	2	3	5	9	45.000°	71%	71%
				10	50.625°	77%	63%
			6	11	56.250°	83%	56%
				12	61.875°	88%	47%
		4	7	13	67.500°	92%	38%
				14	73.125°	96%	29%
			8	15	78.750°	98%	20%
				16	84.375°	100%	10%
	3	5	9	17	90.000°	100%	0%
				18	95.625°	100%	-10%
			10	19	101.250°	98%	-20%
				20	106.875°	96%	-29%
		6	11	21	112.500°	92%	-38%
				22	118.125°	88%	-47%
			12	23	123.750°	83%	-56%
				24	129.375°	77%	-63%
2	4	7	13	25	135.000°	71%	-71%
				26	140.625°	63%	-77%
			14	27	146.250°	56%	-83%
				28	151.875°	47%	-88%
		8	15	29	157.500°	38%	-92%
				30	163.125°	29%	-96%
			16	31	168.750°	20%	-98%
				32	174.375°	10%	-100%
	5	9	17	33	180.000°	0%	-100%
				34	185.625°	-10%	-100%
			18	35	191.250°	-20%	-98%
				36	196.875°	-29%	-96%
		10	19	37	202.500°	-38%	-92%
				38	208.125°	-47%	-88%
			20	39	213.750°	-56%	-83%
				40	219.375°	-63%	-77%
3	6	11	21	41	225.000°	-71%	-71%
				42	230.625°	-77%	-63%
			22	43	236.250°	-83%	-56%
				44	241.875°	-88%	-47%
		12	23	45	247.500°	-92%	-38%
				46	253.125°	-96%	-29%
			24	47	258.750°	-98%	-20%

**Table 3. Microstepping Relative Current Per Step (continued)**

FULL STEP	1/2 STEP	1/4 STEP	1/8 STEP	1/16 STEP	ELECTRICAL ANGLE (°)	AOUT CURRENT (% full-scale)	BOUT CURRENT (% full-scale)
				48	264.375°	-100%	-10%
	7	13	25	49	270.000°	-100%	0%
				50	275.625°	-100%	10%
			26	51	281.250°	-98%	20%
				52	286.875°	-96%	29%
		14	27	53	292.500°	-92%	38%
				54	298.125°	-88%	47%
			28	55	303.750°	-83%	56%
				56	309.375°	-77%	63%
4	8	15	29	57	315.000°	-71%	71%
				58	320.625°	-63%	77%
			30	59	326.250°	-56%	83%
				60	331.875°	-47%	88%
		16	31	61	337.500°	-38%	92%
				62	343.125°	-29%	96%
			32	63	348.750°	-20%	98%
				64	354.375°	-10%	100%
	1	1	1	1	360.000°	0%	100%

Non-circular 1/2-step operation is shown in [Table 4](#). This stepping mode consumes more power than circular 1/2-step operation, but provides a higher torque at high motor rpm.

**Table 4. Non-Circular 1/2-Stepping Current**

NON-CIRCULAR 1/2 STEP	ELECTRICAL ANGLE (°)	AOUT CURRENT (% FULL-SCALE)	BOUT CURRENT (% FULL-SCALE)
1	0°	0	100
2	45°	100	100
3	90°	100	0
4	135°	100	-100
5	180°	0	-100
6	225°	-100	-100
7	270°	-100	0
8	315°	-100	100

### 7.3.4 Current Regulation

The current through the motor windings is regulated by an adjustable fixed-off-time PWM current regulation circuit. When an H-bridge is enabled, current rises through the winding at a rate dependent on the DC voltage, inductance of the winding, and the magnitude of the back EMF present. After the current hits the current chopping threshold, the bridge enters a decay mode for a fixed period of time to decrease the current, which is configurable between 10 and 30  $\mu\text{s}$  through the tri-level input TOFF. After the off time expires, the bridge is re-enabled, starting another PWM cycle.

**Table 5. Off-Time Settings**

TOFF	OFF-TIME $t_{\text{OFF}}$
0	20 $\mu\text{s}$
1	30 $\mu\text{s}$
Z	10 $\mu\text{s}$

The PWM chopping current is set by a comparator which compares the voltage across a current sense resistor connected to the xISEN pin with a reference voltage. To generate the reference voltage for the current chopping comparator, the output of a sine lookup table is applied to a sine-weighted DAC, whose full-scale output voltage is set by VREF. This voltage is attenuated by a factor of  $A_v$ . In addition, the TRQx pins further scale the reference.

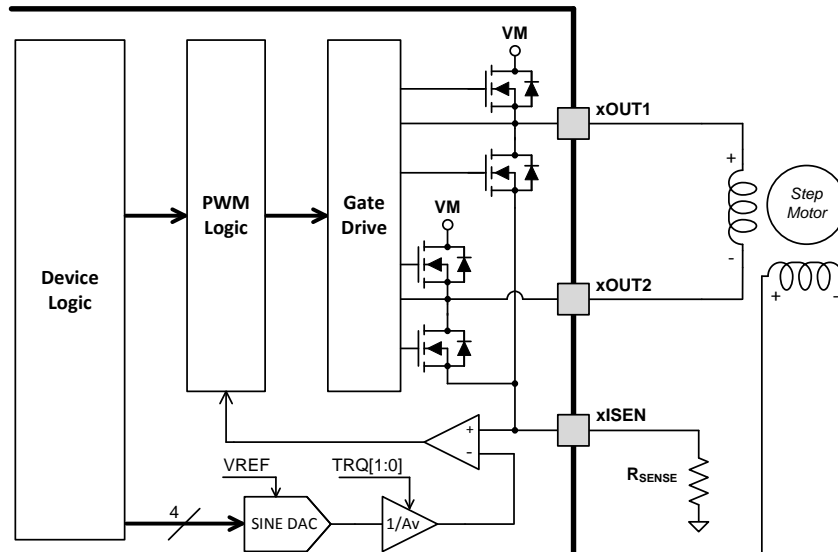

**Figure 14. Current Regulation Block Diagram**

The full-scale (100%) chopping current is calculated as follows:

$$I_{\text{FS}} (\text{A}) = \frac{V_{\text{REF}} (\text{V}) \times \text{TRQ} (\%) }{A_v \times R_{\text{SENSE}} (\Omega)} = \frac{V_{\text{REF}} (\text{V}) \times \text{TRQ} (\%) }{6.6 \times R_{\text{SENSE}} (\Omega)} \quad (1)$$

The TRQx pins are the inputs to a Torque DAC used to scale the output current. The current scalar value for different inputs is shown below.

**Table 6. Torque DAC Settings**

TRQ1	TRQ0	CURRENT SCALAR (TRQ)	EFFECTIVE ATTENUATION
1	1	25%	26.4 V/V
1	0	50%	13.2 V/V
0	1	75%	8.8 V/V
0	0	100%	6.6 V/V

Table 7 gives the xISEN trip voltage at a given DAC code and TRQ[1:0] setting for 1/16 step mode. In this table, VREF = 3.3 V.

**Table 7. xISEN Trip Voltages over Torque DAC and Microsteps**

1/16 STEP (SINE DAC CODE)	TORQUE DAC TRQ[1:0] SETTING			
	00 – 100%	01 – 75%	10 – 50%	11 – 25%
16	500.0 mV	375.0 mV	250.0 mV	125.0 mV
15	490.0 mV	367.5 mV	245.0 mV	122.5 mV
14	480.0 mV	360.0 mV	240.0 mV	120.0 mV
13	460.0 mV	345.0 mV	230.0 mV	115.0 mV
12	440.0 mV	330.0 mV	220.0 mV	110.0 mV
11	415.0 mV	311.3 mV	207.5 mV	103.8 mV
10	385.0 mV	288.8 mV	192.5 mV	96.3 mV
9	355.0 mV	266.3 mV	177.5 mV	88.8 mV
8	315.0 mV	236.3 mV	157.5 mV	78.8 mV
7	280.0 mV	210.0 mV	140.0 mV	70.0 mV
6	235.0 mV	176.3 mV	117.5 mV	58.8 mV
5	190.0 mV	142.5 mV	95.0 mV	47.5 mV
4	145.0 mV	108.8 mV	72.5 mV	36.3 mV
3	100.0 mV	75.0 mV	50.0 mV	25.0 mV
2	50.0 mV	37.5 mV	25.0 mV	12.5 mV
1	0.0 mV	0.0 mV	0.0 mV	0.0 mV

### 7.3.5 Decay Modes

A fixed decay mode is selected by setting the tri-level DECAYx pins as shown in Table 8. Please note that if the ATE pin is logic high, the DECAYx pins are ignored and AutoTune is used.

**Table 8. Decay Mode Settings**

DECAY1	DECAY0	INCREASING STEPS	DECREASING STEPS
0	0	Slow Decay	Slow Decay
0	1	Slow Decay	Mixed Decay: 2 t <sub>BLANK</sub>
1	0	Slow Decay	Mixed Decay: 30% Fast
1	1	Mixed Decay: 30% Fast	Mixed Decay: 30% Fast
0	Z	Slow Decay	Mixed Decay: 60% Fast
1	Z	Slow Decay	Fast Decay
Z	0	Mixed Decay: 1 t <sub>BLANK</sub>	Mixed Decay: 30% Fast
Z	1	Mixed Decay: 60% Fast	Mixed Decay: 60% Fast
Z	Z	Fast Decay	Fast Decay

Increasing and decreasing current are defined in the chart below. For the Slow/Mixed decay mode, the decay mode is set as slow during increasing current steps and mixed decay during decreasing current steps. In full step mode, the increasing step decay mode is always used.

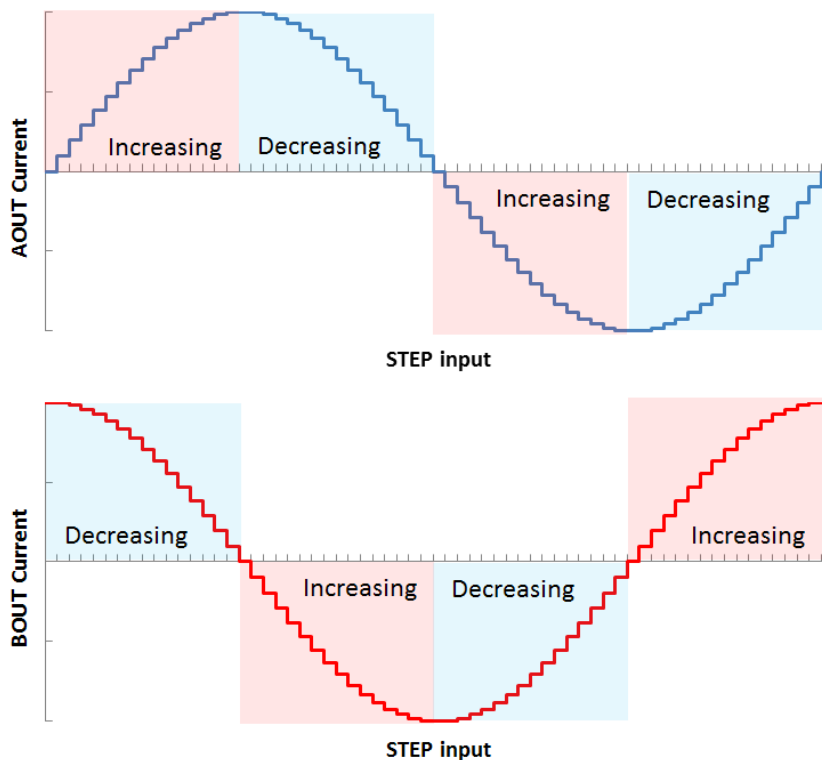

**Figure 15. Definition of Increasing and Decreasing Steps**

**7.3.5.1 Mode 1: Slow Decay for Increasing and Decreasing Current**

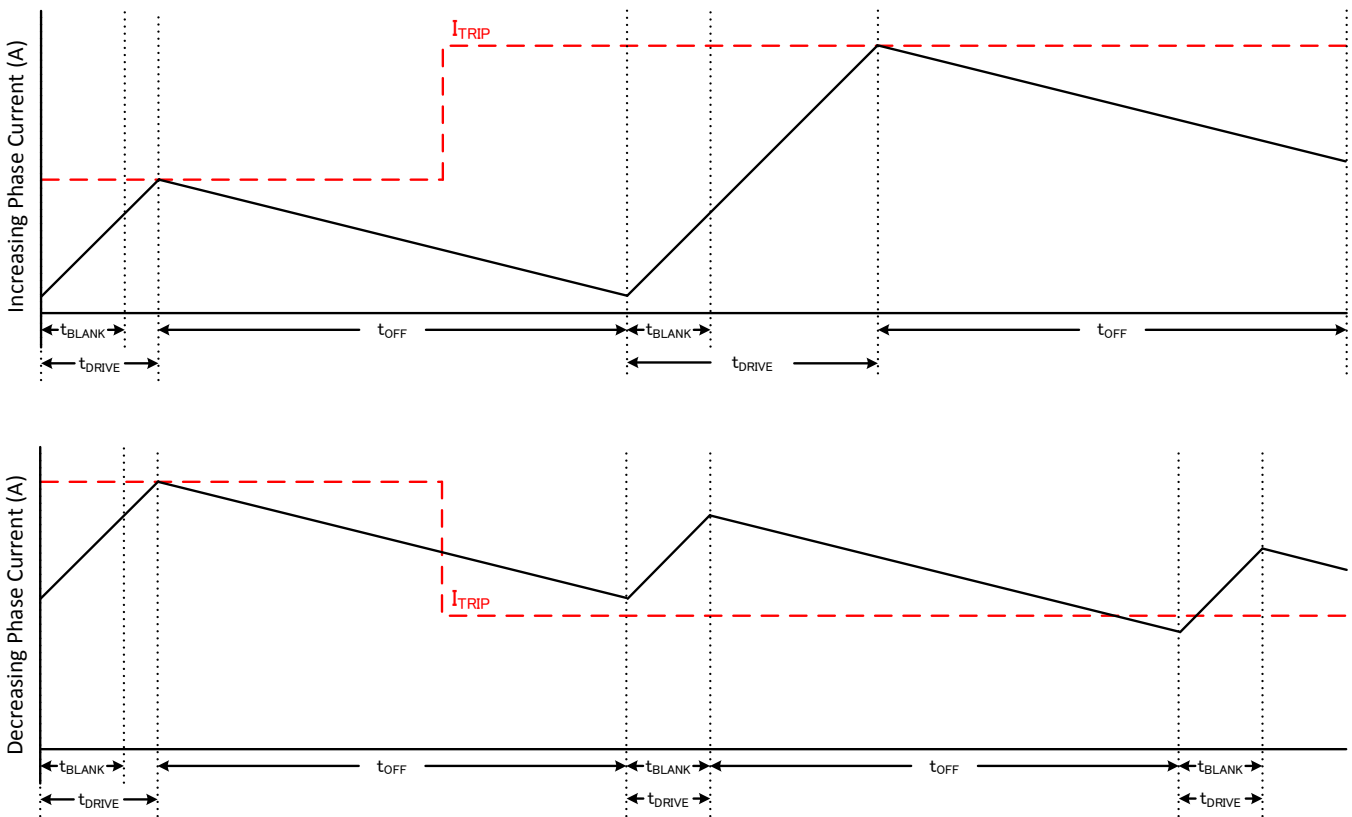

**Figure 16. Slow/Slow Decay Mode**

During slow decay, both of the low-side FETs of the H-bridge are turned on, allowing the current to be recirculated.

Slow decay exhibits the least current ripple of the decay modes for a given  $t_{OFF}$ . However on decreasing current steps, slow decay will take a long time to settle to the new  $I_{TRIP}$  level because the current decreases very slowly.

In cases where current is held for a long time (no input in the STEP pin) or at very low stepping speeds, slow decay may not properly regulate current because no back-EMF is present across the motor windings. In this state, motor current can rise very quickly, and may require a large off-time. In some cases this may cause a loss of current regulation, and a more aggressive decay mode is recommended.

7.3.5.2 Mode 2: Slow Decay for Increasing Current, Mixed Decay for Decreasing current

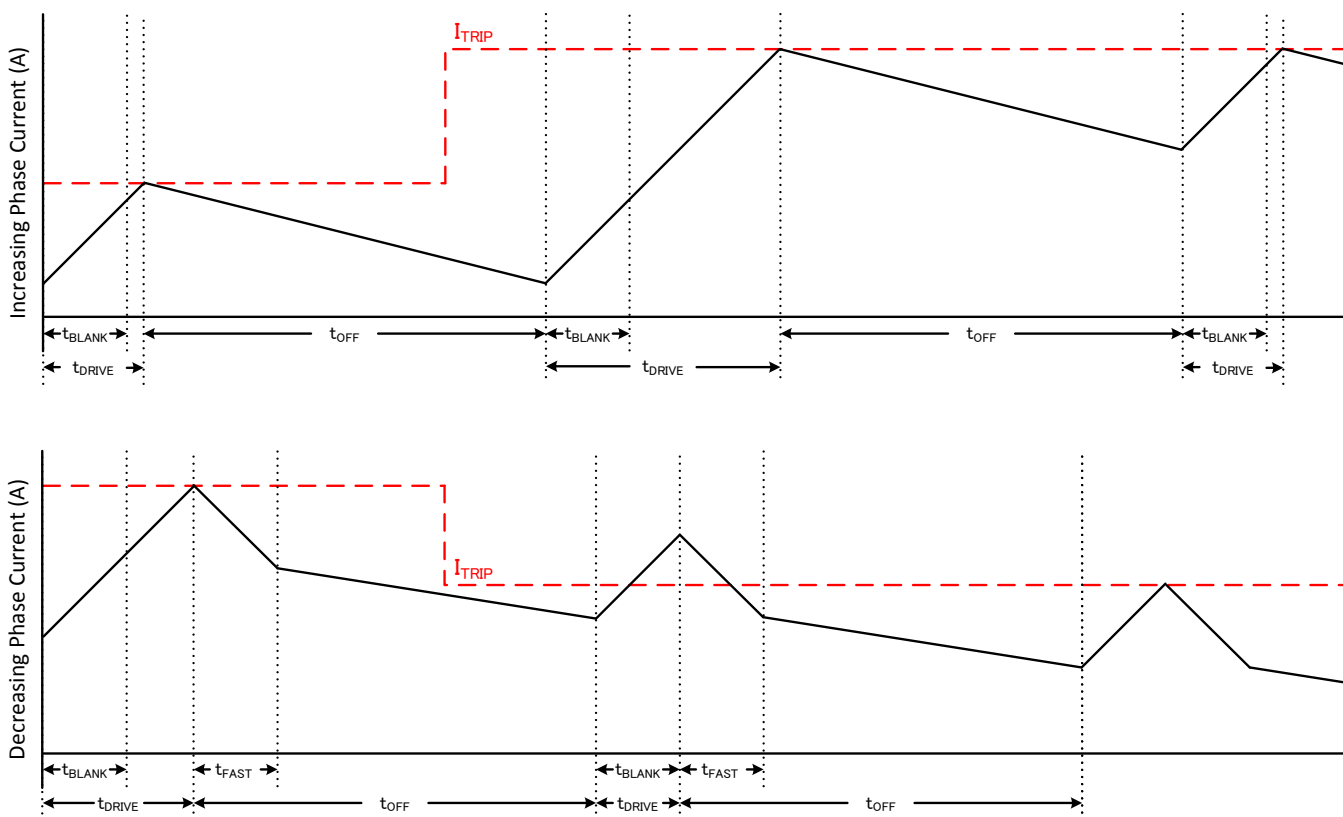

Figure 17. Slow/Mixed Decay Mode

Mixed decay begins as fast decay for a time, followed by slow decay for the remainder of  $t_{OFF}$ . In this mode, mixed decay only occurs during decreasing current. Slow decay is used for increasing current.

This mode exhibits the same current ripple as slow decay for increasing current, since for increasing current, only slow decay is used. For decreasing current, the ripple is larger than slow decay, but smaller than fast decay. On decreasing current steps, mixed decay will settle to the new  $I_{TRIP}$  level faster than slow decay.

In cases where current is held for a long time (no input in the STEP pin) or at very low stepping speeds, slow decay may not properly regulate current because no back-EMF is present across the motor windings. In this state, motor current can rise very quickly, and may require a large off-time. In some cases this may cause a loss of current regulation, and a more aggressive decay mode is recommended.

### 7.3.5.3 Mode 3: Mixed Decay for Increasing and Decreasing Current

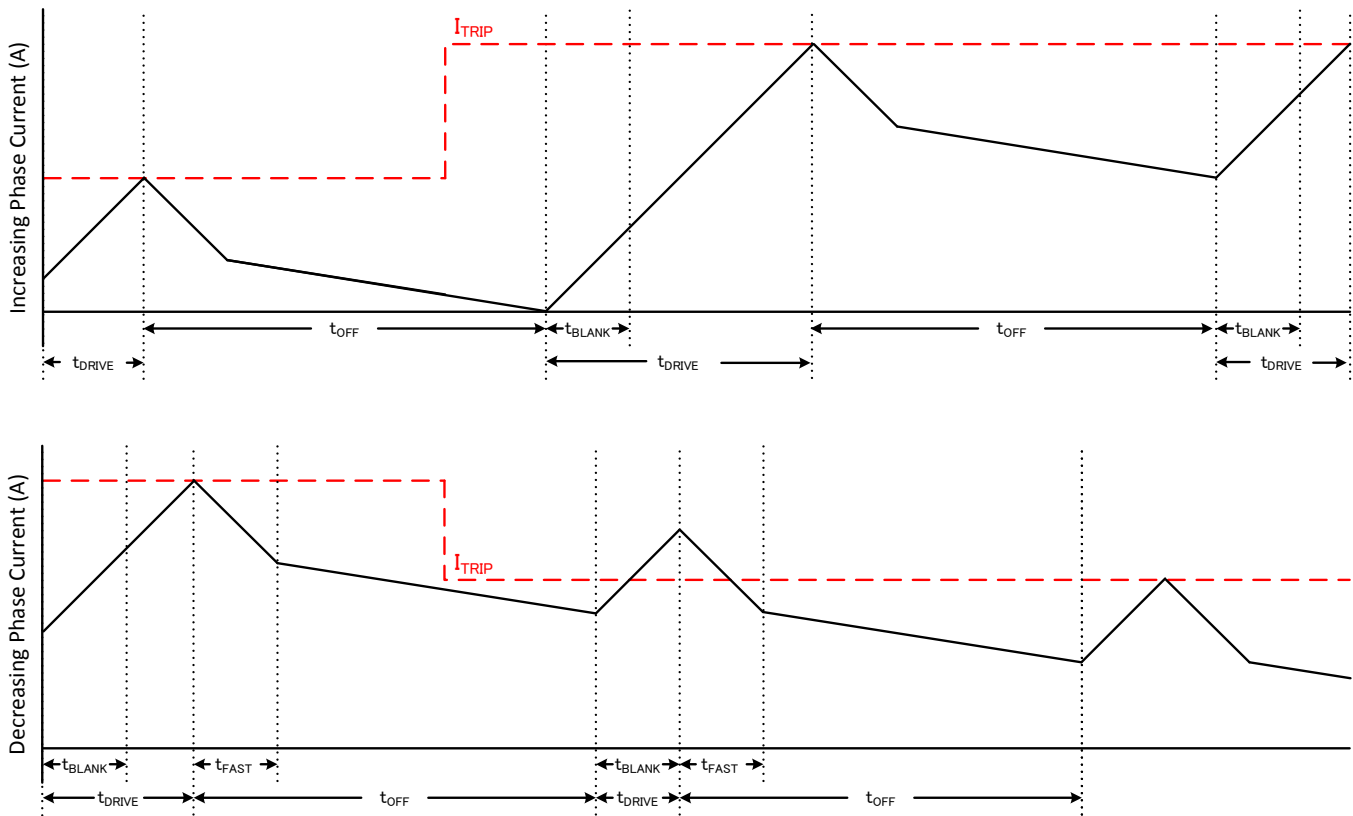

**Figure 18. Mixed/Mixed Decay Mode**

Mixed decay begins as fast decay for a time, followed by slow decay for the remainder of  $t_{OFF}$ . In this mode, mixed decay occurs for both increasing and decreasing current steps.

This mode exhibits ripple larger than slow decay, but smaller than fast decay. On decreasing current steps, mixed decay will settle to the new  $I_{TRIP}$  level faster than slow decay.

In cases where current is held for a long time (no input in the STEP pin) or at very low stepping speeds, slow decay may not properly regulate current because no back-EMF is present across the motor windings. In this state, motor current can rise very quickly, and requires an excessively large off-time. Increasing/decreasing mixed decay mode allows the current level to stay in regulation when no back-EMF is present across the motor windings.

7.3.5.4 Mode 4: Slow Decay for Increasing Current, Fast Decay for Decreasing current

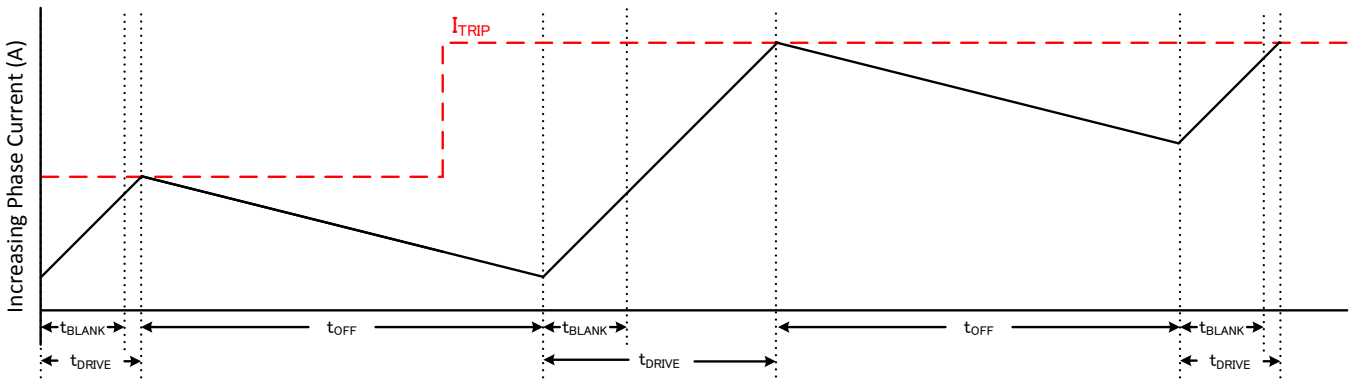

Please note that these graphs are not the same scale; t<sub>OFF</sub> is the same

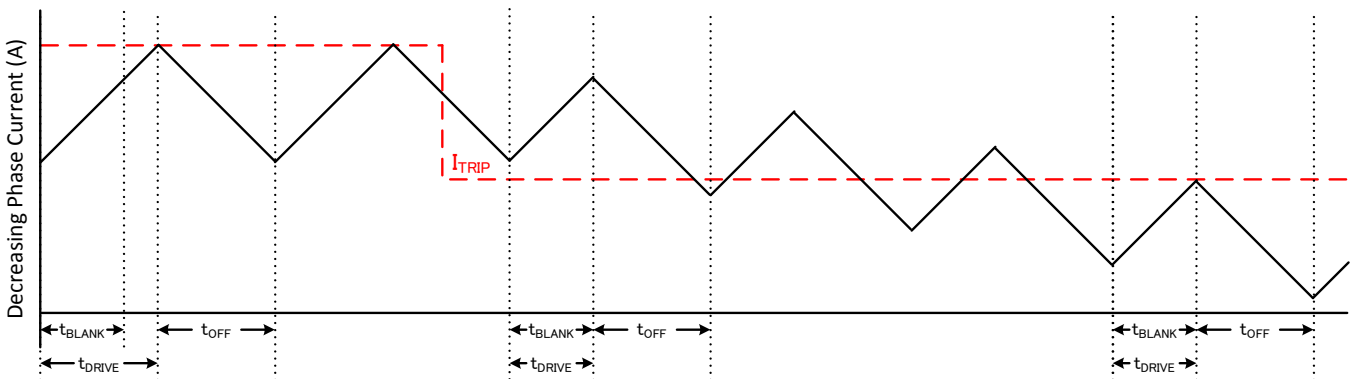

Figure 19. Slow/Fast Decay Mode

During fast decay, the polarity of the H-bridge is reversed. The H-bridge will be turned off as current approaches zero in order to prevent current flow in the reverse direction. In this mode, fast decay only occurs during decreasing current. Slow decay is used for increasing current.

Fast decay exhibits the highest current ripple of the decay modes for a given t<sub>OFF</sub>. Transition time on decreasing current steps is much faster than slow decay since the current is allowed to decrease much faster.

7.3.5.5 Mode 5: Fast Decay for Increasing and Decreasing Current

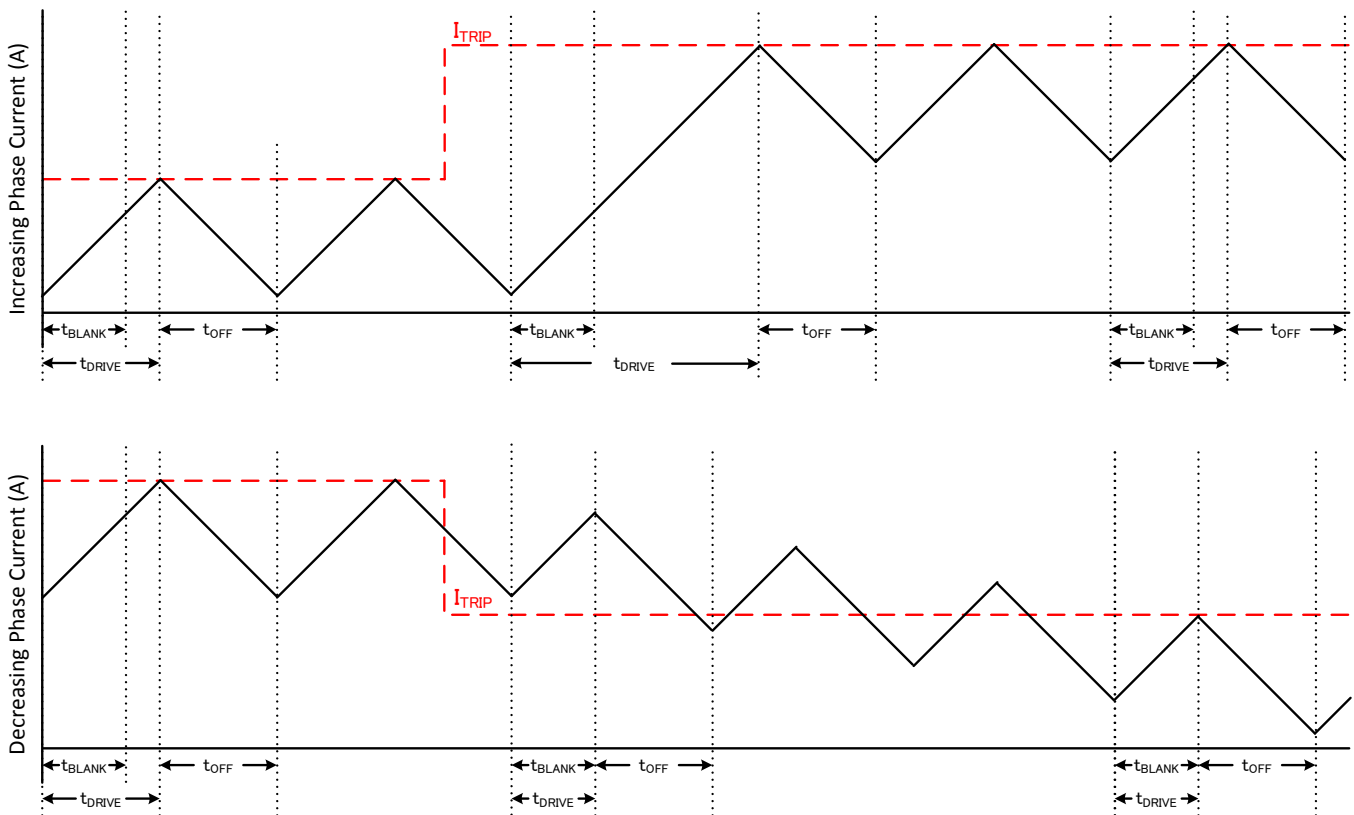

Figure 20. Fast/Fast Decay Mode

During fast decay, the polarity of the H-bridge is reversed. The H-bridge will be turned off as current approaches zero in order to prevent current flow in the reverse direction.

Fast decay exhibits the highest current ripple of the decay modes for a given  $t_{OFF}$ . Transition time on decreasing current steps is much faster than slow decay since the current is allowed to decrease much faster.

### 7.3.6 AutoTune

To enable the AutoTune mode, pull the ATE pin logic high. Ensure the DECAYx pins are logic low. The AutoTune mode is registered internally when exiting from sleep mode or the power-up sequence. The ATE pin can be shorted to V3P3 to pull it logic high for this purpose.

AutoTune greatly simplifies the decay mode selection by automatically configuring the decay mode between slow, mixed, and fast decay. In mixed decay, AutoTune dynamically adjusts the fast decay percentage of the total mixed decay time. This feature eliminates motor tuning by automatically determining the best decay setting that results in the lowest ripple for the motor.

The decay mode setting is optimized iteratively each PWM cycle. If the motor current overshoots the target trip level, then the decay mode becomes more aggressive (add fast decay percentage) on the next cycle in order to prevent regulation loss. If there is a long drive time to reach the target trip level, the decay mode becomes less aggressive (remove fast decay percentage) on the next cycle in order to operate with less ripple and more efficiently. On falling steps, AutoTune will automatically switch to fast decay in order to reach the next step quickly.

AutoTune will automatically adjust the decay scheme based on operating factors like:

- Motor winding resistance and inductance
- Motor aging effects
- Motor dynamic speed and load
- Motor supply voltage variation
- Motor back-EMF difference on rising and falling steps
- Step transitions
- Low-current vs. high-current  $di/dt$

### 7.3.7 Adaptive Blanking Time

After the current is enabled in an H-bridge, the voltage on the xISEN pin is ignored for a period of time before enabling the current sense circuitry. Note that the blanking time also sets the minimum drive time of the PWM.

The blanking time is automatically scaled so that the drive time is reduced at lower current steps.

The time  $t_{BLANK}$  is determined by the sine DAC code and the torque DAC setting. The timing information for  $t_{BLANK}$  is given in [Table 9](#).

**Table 9. Adaptive Blanking Time Settings over Torque DAC and Microsteps**

SINE DAC CODE	TORQUE DAC TRQ[1:0] SETTING			
	00 – 100%	01 – 75%	10 – 50%	11 – 25%
16	1.80 $\mu$ s	1.50 $\mu$ s	1.50 $\mu$ s	1.20 $\mu$ s
15	1.80 $\mu$ s	1.50 $\mu$ s	1.50 $\mu$ s	1.20 $\mu$ s
14	1.80 $\mu$ s	1.50 $\mu$ s	1.50 $\mu$ s	1.20 $\mu$ s
13	1.80 $\mu$ s	1.50 $\mu$ s	1.50 $\mu$ s	1.20 $\mu$ s
12	1.80 $\mu$ s	1.50 $\mu$ s	1.50 $\mu$ s	1.20 $\mu$ s
11	1.80 $\mu$ s	1.50 $\mu$ s	1.50 $\mu$ s	1.20 $\mu$ s
10	1.80 $\mu$ s	1.50 $\mu$ s	1.50 $\mu$ s	1.20 $\mu$ s
9	1.80 $\mu$ s	1.50 $\mu$ s	1.50 $\mu$ s	1.20 $\mu$ s
8	1.50 $\mu$ s	1.50 $\mu$ s	1.20 $\mu$ s	0.90 $\mu$ s
7	1.50 $\mu$ s	1.50 $\mu$ s	1.20 $\mu$ s	0.90 $\mu$ s
6	1.50 $\mu$ s	1.50 $\mu$ s	1.20 $\mu$ s	0.90 $\mu$ s
5	1.50 $\mu$ s	1.50 $\mu$ s	1.20 $\mu$ s	0.90 $\mu$ s
4	1.20 $\mu$ s	1.20 $\mu$ s	0.90 $\mu$ s	0.90 $\mu$ s
3	1.20 $\mu$ s	1.20 $\mu$ s	0.90 $\mu$ s	0.90 $\mu$ s
2	0.90 $\mu$ s	0.90 $\mu$ s	0.90 $\mu$ s	0.90 $\mu$ s
1	0.90 $\mu$ s	0.90 $\mu$ s	0.90 $\mu$ s	0.90 $\mu$ s

### 7.3.8 Charge Pump

A charge pump is integrated in order to supply a high-side NMOS gate drive voltage. The charge pump requires a capacitor between the VM and VCP pins. Additionally a low-ESR ceramic capacitor is required between pins CPH and CPL.

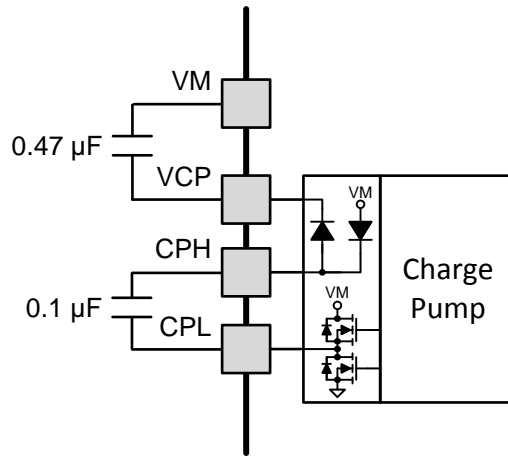

Figure 21. Charge Pump Diagram

### 7.3.9 LDO Voltage Regulator

An LDO regulator is integrated into the DRV8880. It can be used to provide the supply voltage for low-current devices. For proper operation, bypass V3P3 to GND using a ceramic capacitor.

The V3P3 output is nominally 3.3 V. When the V3P3 LDO current load exceeds 10 mA, the LDO will behave like a constant current source. The output voltage will drop significantly with currents greater than 10 mA.

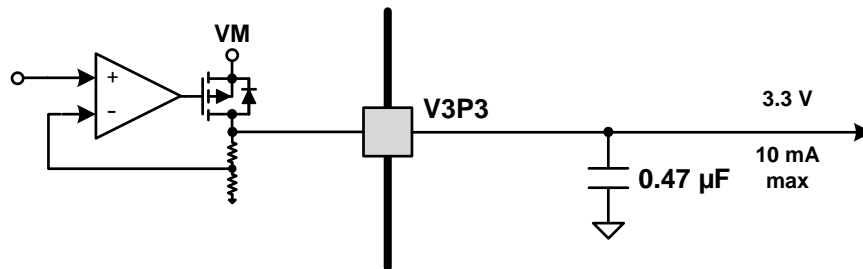
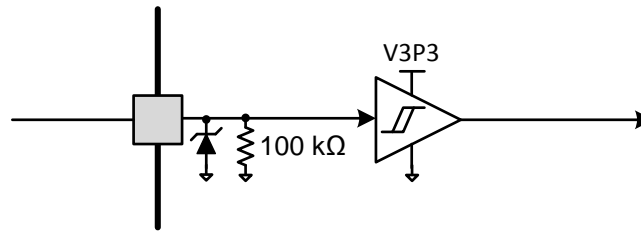

Figure 22. LDO Diagram

If a digital input needs to be tied permanently high (that is, M or TOFF), it is preferable to tie the input to V3P3 instead of an external regulator. This will save power when VM is not applied or in sleep mode: V3P3 is disabled and current will not be flowing through the input pulldown resistors. For reference, logic level inputs have a typical pulldown of 100 kΩ, and tri-level inputs have a typical pulldown of 40 kΩ.

### 7.3.10 Logic and Tri-Level Pin Diagrams

The diagram below gives the input structure for logic-level pins STEP, DIR, ENABLE, nSLEEP, TRQ0, TRQ1, and ATE:



**Figure 23. Logic-level Input Pin Diagram**

Tri-level logic pins TOFF, M0, M1, DECAY0, and DECAY1 have the following structure:

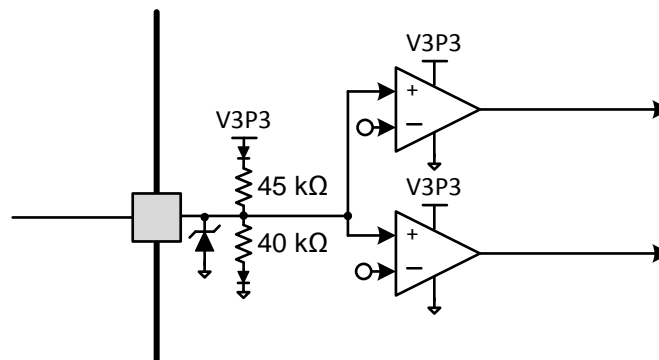

**Figure 24. Tri-level Input Pin Diagram**

### 7.3.11 Power Supplies and Input Pins

The control pins and reference input pin can be driven within the recommended operating conditions without the VM power supply present, or when the device is in sleep mode.

Each control pin has a weak pulldown resistor to ground. TI recommends setting the inputs to a logic low when in sleep mode to minimize current through the pulldown resistors.

### 7.3.12 Protection Circuits

The DRV8880 is fully protected against undervoltage, charge pump undervoltage, overcurrent, and overtemperature events.

### 7.3.13 VM UVLO (UVLO2)

If at any time the voltage on the VM pin falls below the VM undervoltage lockout threshold voltage ( $V_{UVLO2}$ ), all FETs in the H-bridge will be disabled, the charge pump will be disabled, and the nFAULT pin will be driven low. Operation will resume when VM rises above the UVLO2 threshold. The nFAULT pin will be released after operation has resumed.

The indexer position is not reset by this fault even though the output drivers are disabled. The indexer position is maintained and internal logic remains active until VM falls below the logic undervoltage threshold ( $V_{UVLO1}$ ).

### 7.3.14 Logic Undervoltage (UVLO1)

If at any time the voltage on the VM pin falls below the logic undervoltage threshold voltage ( $V_{UVLO1}$ ), the internal logic is reset, and the V3P3 regulator is disabled. Operation will resume when VM rises above the UVLO1 threshold. The nFAULT pin is logic low during this state since it is pulled low upon encountering VM undervoltage. Decreasing VM below this undervoltage threshold will reset the indexer position.

### 7.3.15 VCP Undervoltage Lockout (CPUV)

If at any time the voltage on the VCP pin falls below the charge pump undervoltage lockout threshold voltage, all FETs in the H-bridge will be disabled and the nFAULT pin will be driven low. Operation will resume when VCP rises above the CPUV threshold. The nFAULT pin will be released after operation has resumed.

### 7.3.16 Thermal Shutdown (TSD)

If the die temperature exceeds safe limits, all FETs in the H-bridge will be disabled and the nFAULT pin will be driven low. Once the die temperature has fallen to a safe level operation will automatically resume. The nFAULT pin will be released after operation has resumed.

### 7.3.17 Overcurrent Protection (OCP)

An analog current limit circuit on each FET limits the current through the FET by removing the gate drive. If this analog current limit persists for longer than  $t_{OCP}$ , all FETs in the H-bridge will be disabled and nFAULT will be driven low. In addition to this FET current limit, an overcurrent condition is also detected if the voltage at xISEN exceeds  $V_{OCP}$ .

The overcurrent fault response can be set to either latched mode or retry mode:

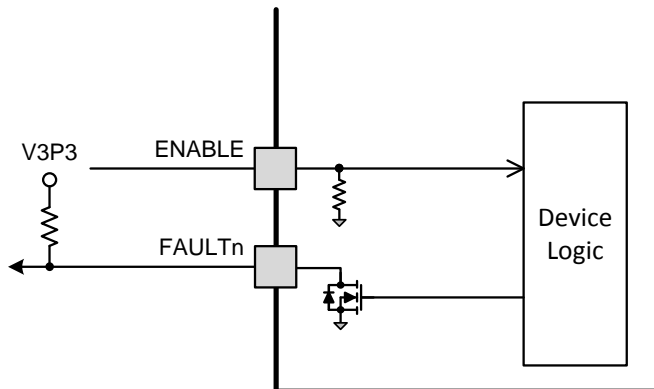

**Figure 25. Latched OCP Mode**

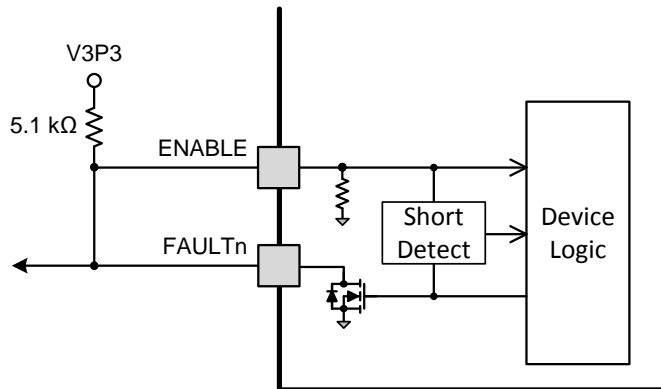

**Figure 26. Retry OCP Mode**

In latched mode, operation will resume after the ENABLE pin is brought logic low for at least  $1 \mu s$  to reset the output driver. The nFAULT pin will be released after ENABLE is returned logic high. Removing and re-applying VM or toggling nSLEEP will also reset the latched fault.

In retry mode, the driver will be re-enabled after the OCP retry period ( $t_{RETRY}$ ) has passed. nFAULT becomes high again after the retry time. If the fault condition is still present, the cycle repeats. If the fault is no longer present, normal operation resumes and nFAULT remains deasserted.

A microcontroller can retain control of the ENABLE pin while in retry mode if it is operated like an open-drain output. Many microcontrollers support this. When the DRV8880 is operating normally, configure the MCU GPIO as an input. In this state, the MCU can detect whenever nFAULT is pulled low. In order to disable the DRV8880 output, configure the GPIO output state as low, and then configure the GPIO as an output.

Alternatively, a logic-level FET may be used to create an open drain external to the MCU. In this case, an additional MCU GPIO may be required in order to monitor the nFAULT pin.

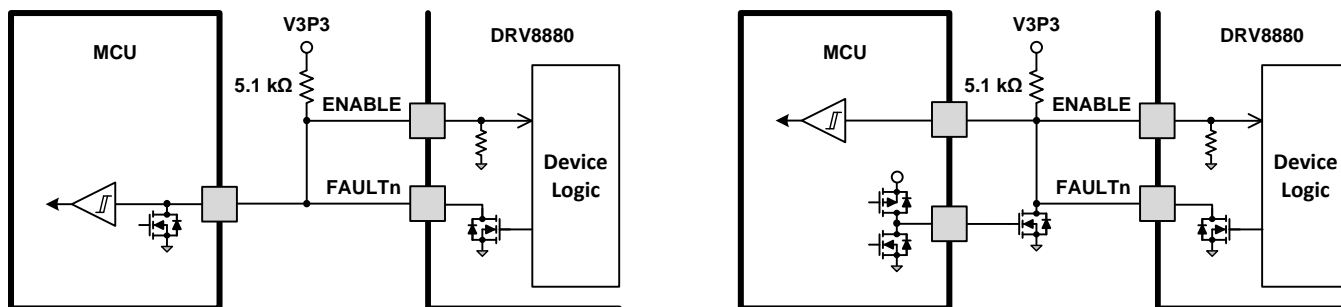

Figure 27. Methods For Operating in Retry Mode

Table 10. Fault Condition Summary

FAULT	CONDITION	ERROR REPORT	H-BRIDGE	CHARGE PUMP	INDEXER	V3P3	RECOVERY
VM undervoltage (UVLO2)	$VM < V_{UVLO2}$ (max 6.4 V)	nFAULT	Disabled	Disabled	Operating	Operating	$VM > V_{UVLO2}$ (max 6.5 V)
Logic undervoltage (UVLO1)	$VM < V_{UVLO1}$ (max 4.9 V)	None	Disabled	Disabled	Disabled	Operating	$VM > V_{UVLO1}$ (max 4.8 V)
VCP undervoltage (CPUV)	$VCP < V_{CPUV}$ (typ $VM + 1.8$ V)	nFAULT	Disabled	Operating	Operating	Operating	$VCP > V_{CPUV}$ (typ $VM + 1.9$ V)
Thermal Shutdown (TSD)	$T_J > T_{TSD}$ (min 150°C)	nFAULT	Disabled	Operating	Operating	Operating	$T_J < T_{TSD} - T_{HYS}$ ( $T_{HYS}$ typ 35°C)
Overcurrent (OCP)	$I_{OUT} > I_{OCP}$ (min 2.5 A) $V_{XISEN} > V_{OCP}$ (min 0.9 V)	nFAULT	Disabled	Operating	Operating	Operating	ENABLE -or- $t_{RETRY}$

## 7.4 Device Functional Modes

The DRV8880 internal logic, indexer, and charge pump are operating unless the nSLEEP pin is brought logic low. In sleep mode the charge pump is disabled, the H-bridge FETs are disabled Hi-Z, and the V3P3 regulator is disabled.  $t_{SLEEP}$  must elapse after a falling edge on the nSLEEP pin before the device is in sleep mode. The DRV8880 is brought out of sleep mode automatically if nSLEEP is brought logic high.  $t_{WAKE}$  must elapse before the outputs change state after wake-up.

If the ENABLE pin is brought logic low, the H-bridge outputs are disabled, but the charge pump and internal logic will remain active. A rising edge on STEP will advance the indexer, but the outputs will not change state until ENABLE brought logic high.

When VM falls below the VM undervoltage lockout threshold  $V_{UVLO2}$ , the output driver and charge pump are disabled, but the internal logic and V3P3 remain active. In this mode, STEP inputs will advance the indexer, but the outputs will remain disabled. If VM falls below the logic undervoltage threshold  $V_{UVLO1}$ , the internal logic is reset and the indexer will lose position.

**Table 11. Functional Modes Summary**

CONDITION		H-BRIDGE	CHARGE PUMP	INDEXER	V3P3
Operating	6.5 V < VM < 45 V nSLEEP pin = 1 ENABLE pin = 1	Operating	Operating	Operating	Operating
Disabled	6.5 V < VM < 45 V nSLEEP pin = 1 ENABLE pin = 0	Disabled	Operating	Operating	Operating
Sleep mode	5.0 V < VM < 45 V nSLEEP pin = 0	Disabled	Disabled	Disabled	Disabled
Fault encountered	VM undervoltage (UVLO2)	Disabled	Disabled	Operating	Operating
	Logic undervoltage (UVLO1)	Disabled	Disabled	Disabled	Operating
	VCP undervoltage (CPUV)	Disabled	Operating	Operating	Operating
	Thermal shutdown (TSD)	Disabled	Operating	Operating	Operating
	Overcurrent (OCP)	Disabled	Operating	Operating	Operating

## 8 Application and Implementation

### NOTE

Information in the following applications sections is not part of the TI component specification, and TI does not warrant its accuracy or completeness. TI's customers are responsible for determining suitability of components for their purposes. Customers should validate and test their design implementation to confirm system functionality.

### 8.1 Application Information

The DRV8880 is used in stepper control.

### 8.2 Typical Application

The following design procedure can be used to configure the DRV8880.

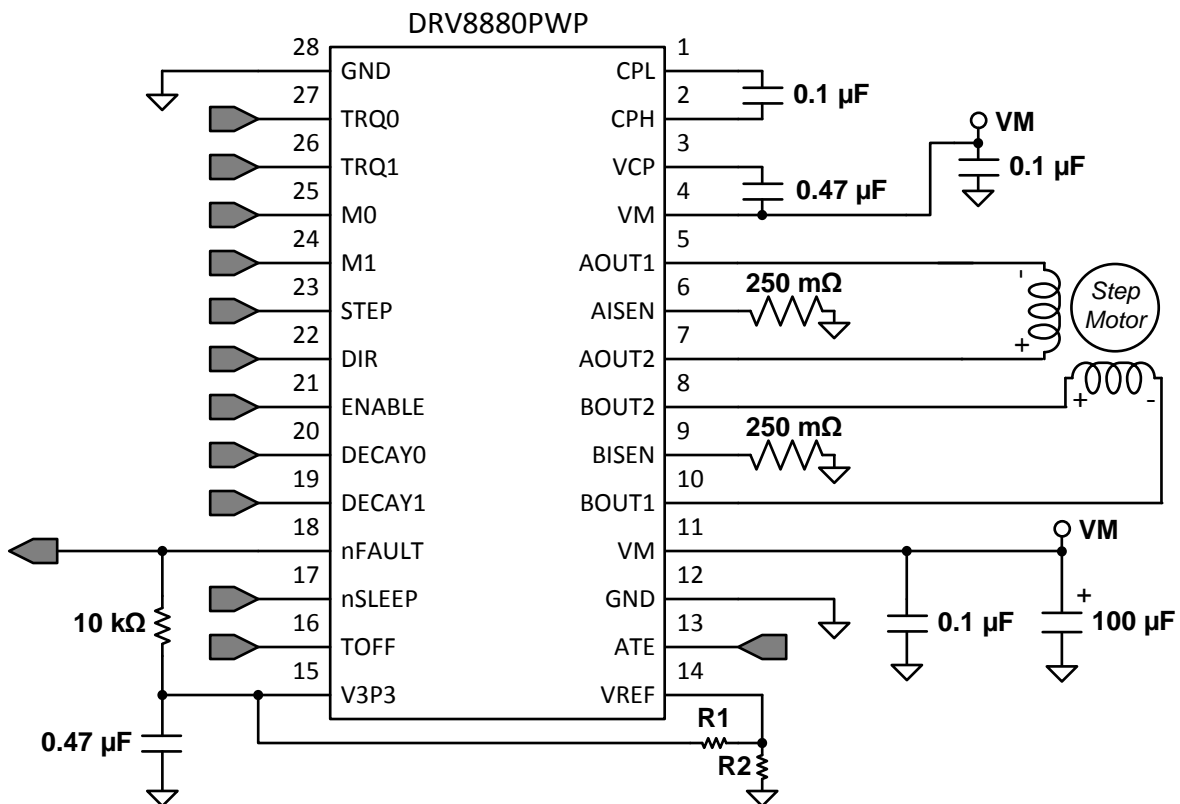

Figure 28. Typical Application Schematic

#### 8.2.1 Design Requirements

Table 12 gives design input parameters for system design.

Table 12. Design Parameters

DESIGN PARAMETER	REFERENCE	EXAMPLE VALUE
Supply voltage	VM	24 V
Motor winding resistance	$R_L$	0.8 $\Omega$ /phase
Motor winding inductance	$L_L$	1.4 mH/phase
Motor full step angle	$\theta_{step}$	1.8°/step
Target microstepping level	$n_m$	1/8 step
Target motor speed	v	120 rpm

**Table 12. Design Parameters (continued)**

DESIGN PARAMETER	REFERENCE	EXAMPLE VALUE
Target full-scale current	I <sub>FS</sub>	1.5 A

**8.2.2 Detailed Design Procedure**

**8.2.2.1 Stepper Motor Speed**

The first step in configuring the DRV8880 requires the desired motor speed and microstepping level. If the target application requires a constant speed, then a square wave with frequency  $f_{step}$  must be applied to the STEP pin.

If the target motor speed is too high, the motor will not spin. Make sure that the motor can support the target speed.

For a desired motor speed ( $v$ ), microstepping level ( $n_m$ ), and motor full step angle ( $\theta_{step}$ ),

$$f_{step} \text{ (steps / s)} = \frac{v \text{ (rpm)} \times 360 \text{ (}^\circ \text{ / rot)}}{\theta_{step} \text{ (}^\circ \text{ / step)} \times n_m \text{ (steps / microstep)} \times 60 \text{ (s / min)}} \tag{2}$$

$\theta_{step}$  can be found in the stepper motor data sheet or written on the motor itself.

For the DRV8880, the microstepping level is set by the Mx pins and can be any of the settings in the table below. Higher microstepping will mean a smoother motor motion and less audible noise, but will increase switching losses and require a higher  $f_{step}$  to achieve the same motor speed.

**Table 13. Microstepping Indexer Settings**

M1	M0	STEP MODE
0	0	Full step (2-phase excitation) with 71% current
0	1	Non-circular 1/2 step
1	0	1/2 step
1	1	1/4 step
0	Z	1/8 step
1	Z	1/16 step

**Example:** Target 120 rpm at 1/8 microstep mode. The motor is 1.8°/step

$$f_{step} \text{ (steps / s)} = \frac{120 \text{ rpm} \times 360^\circ \text{ / rot}}{1.8^\circ \text{ / step} \times 1/8 \text{ steps / microstep} \times 60 \text{ s / min}} = 3.2 \text{ kHz} \tag{3}$$

**8.2.2.2 Current Regulation**

In a stepper motor, the full-scale current ( $I_{FS}$ ) is the maximum current driven through either winding. This quantity will depend on the TRQ pins, the VREF analog voltage, and the sense resistor value ( $R_{SENSE}$ ). During stepping,  $I_{FS}$  defines the current chopping threshold ( $I_{TRIP}$ ) for the maximum current step.

$$I_{FS} \text{ (A)} = \frac{VREF \text{ (V)} \times TRQ \text{ (\%)}}{A_v \times R_{SENSE} \text{ (\Omega)}} = \frac{VREF \text{ (V)} \times TRQ \text{ (\%)}}{6.6 \times R_{SENSE} \text{ (\Omega)}} \tag{4}$$

TRQ is a DAC used to scale the output current. The current scalar value for different inputs is shown below.

**Table 14. Torque DAC Settings**

TRQ1	TRQ0	CURRENT SCALAR (TRQ)
1	1	25%
1	0	50%
0	1	75%
0	0	100%

**Example:** If the desired full-scale current is 1.5 A

Set  $R_{\text{SENSE}} = 100 \text{ m}\Omega$ , assume  $\text{TRQ} = 100\%$ .

$V_{\text{REF}}$  would have to be 0.99 V.

Create a resistor divider from V3P3 (3.3 V) to set  $V_{\text{REF}} \approx 0.99 \text{ V}$ .

Set  $R_2 = 10 \text{ k}\Omega$ , set  $R_1 = 22 \text{ k}\Omega$

Note that  $I_{\text{FS}}$  must also follow the equation below in order to avoid saturating the motor.  $V_{\text{M}}$  is the motor supply voltage, and  $R_{\text{L}}$  is the motor winding resistance.

$$I_{\text{FS}} (\text{A}) < \frac{V_{\text{M}} (\text{V})}{R_{\text{L}} (\Omega) + 2 \times R_{\text{DS(ON)}} (\Omega) + R_{\text{SENSE}} (\Omega)} \quad (5)$$

### 8.2.2.3 Decay Modes

The DRV8880 supports several different decay modes: slow decay, fast decay, mixed decay, and AutoTune. The current through the motor windings is regulated using an adjustable fixed-time-off scheme. This means that after any drive phase, when a motor winding current has hit the current chopping threshold ( $I_{\text{TRIP}}$ ), the DRV8880 will place the winding in one of the decay modes for  $t_{\text{OFF}}$ . After  $t_{\text{OFF}}$ , a new drive phase starts. For fixed decay modes (slow, fast, and mixed), the best setting can be determined by operating the motor and choosing the best setting.

### 8.2.2.4 Sense Resistor

For optimal performance, it is important for the sense resistor to be:

- Surface-mount
- Low inductance
- Rated for high enough power
- Placed closely to the motor driver

The power dissipated by the sense resistor equals  $I_{\text{rms}}^2 \times R$ . For example, if the rms motor current is 1.4A and a 250 m $\Omega$  sense resistor is used, the resistor will dissipate  $1.4 \text{ A}^2 \times 0.25 \text{ }\Omega = 0.49 \text{ W}$ . The power quickly increases with higher current levels.

Resistors typically have a rated power within some ambient temperature range, along with a derated power curve for high ambient temperatures. When a PCB is shared with other components generating heat, margin should be added. It is always best to measure the actual sense resistor temperature in a final system, along with the power MOSFETs, as those are often the hottest components.

Because power resistors are larger and more expensive than standard resistors, it is common practice to use multiple standard resistors in parallel, between the sense node and ground. This distributes the current and heat dissipation.

### 8.2.3 Application Curves

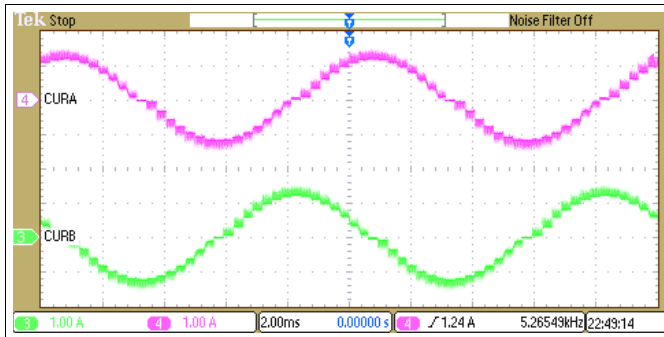

Figure 29. Mixed Decay 30% Fast on Increasing and Decreasing Steps

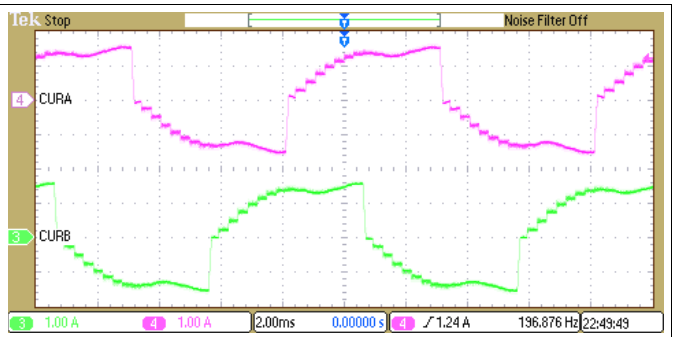

Figure 30. Slow Decay on Increasing and Decreasing Steps

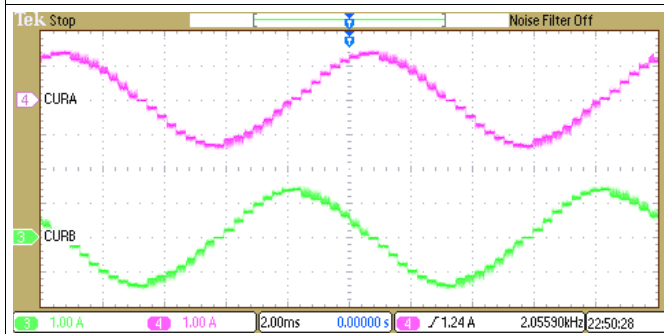

Figure 31. Slow Decay on Increasing and Mixed Decay 30% Fast on Decreasing Steps

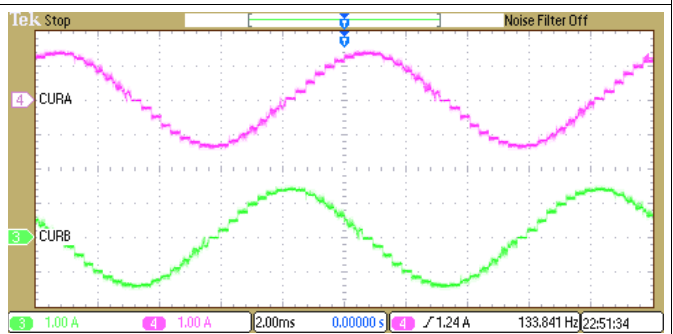

Figure 32. AutoTune

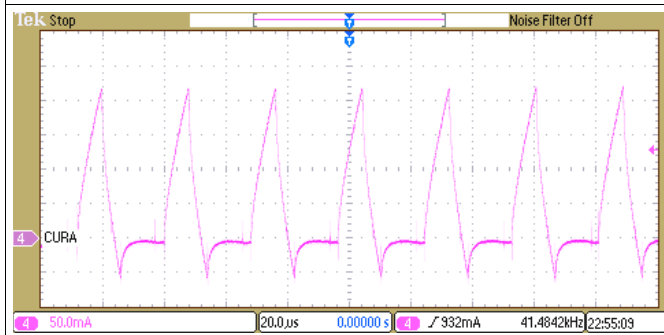

Figure 33. Mixed Decay 30% Fast on Increasing and Decreasing Steps

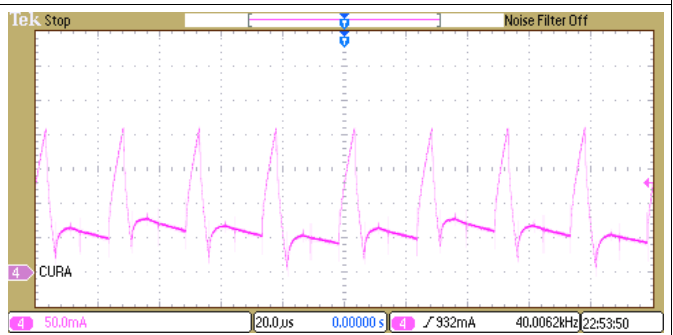

Figure 34. AutoTune

## 9 Power Supply Recommendations

The DRV8880 is designed to operate from an input voltage supply (VM) range between 6.5 V and 45 V. The device has an absolute maximum rating of 50 V. A 0.1- $\mu$ F ceramic capacitor rated for VM must be placed at each VM pin as close to the DRV8880 as possible. In addition, a bulk capacitor must be included on VM.

### 9.1 Bulk Capacitance Sizing

Having appropriate local bulk capacitance is an important factor in motor drive system design. It is generally beneficial to have more bulk capacitance, while the disadvantages are increased cost and physical size.

The amount of local capacitance needed depends on a variety of factors, including:

- The highest current required by the motor system
- The power supply's capacitance and ability to source current
- The amount of parasitic inductance between the power supply and motor system
- The acceptable voltage ripple
- The type of motor used (brushed DC, brushless DC, stepper)
- The motor braking method

The inductance between the power supply and motor drive system will limit the rate current can change from the power supply. If the local bulk capacitance is too small, the system will respond to excessive current demands or dumps from the motor with a change in voltage. When adequate bulk capacitance is used, the motor voltage remains stable and high current can be quickly supplied.

The data sheet generally provides a recommended value, but system-level testing is required to determine the appropriate sized bulk capacitor.

The voltage rating for bulk capacitors should be higher than the operating voltage, to provide margin for cases when the motor transfers energy to the supply.

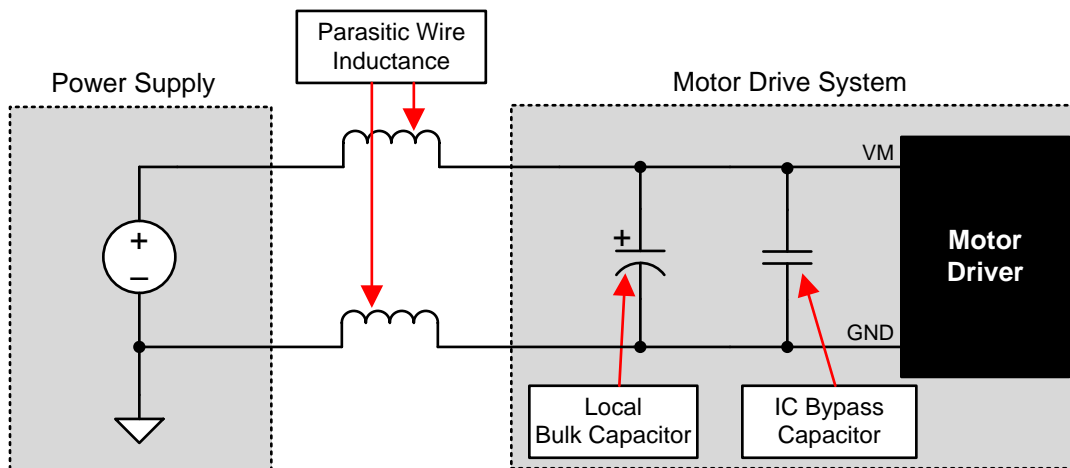

**Figure 35. Setup of Motor Drive System With External Power Supply**

## 10 Layout

### 10.1 Layout Guidelines

Each VM terminal must be bypassed to GND using a low-ESR ceramic bypass capacitors with recommended values of 0.1  $\mu\text{F}$  rated for VM. These capacitors should be placed as close to the VM pins as possible with a thick trace or ground plane connection to the device GND pin.

The VM pin must be bypassed to ground using a bulk capacitor rated for VM. This component may be an electrolytic.

A low-ESR ceramic capacitor must be placed in between the CPL and CPH pins. A value of 0.1  $\mu\text{F}$  rated for VM is recommended. Place this component as close to the pins as possible.

A low-ESR ceramic capacitor must be placed in between the VM and VCP pins. A value of 0.47  $\mu\text{F}$  rated for 16 V is recommended. Place this component as close to the pins as possible.

Bypass V3P3 to ground with a ceramic capacitor rated 6.3 V. Place this bypassing capacitor as close to the pin as possible.

The current sense resistors should be placed as close as possible to the device pins in order to minimize trace inductance between the pin and resistor.

### 10.2 Layout Example

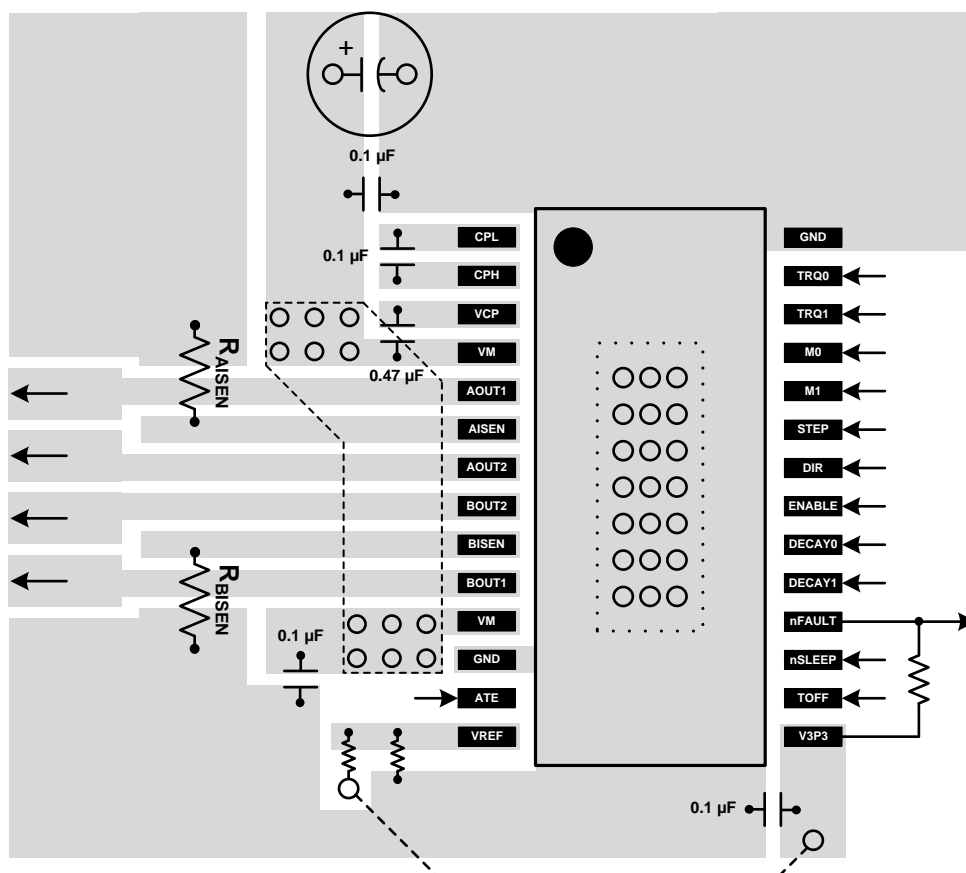

**Figure 36. Layout Recommendation**

## 11 器件和文档支持

### 11.1 文档支持

#### 11.1.1 相关文档

- 德州仪器 (TI), 《[PowerPAD™ 热增强型封装](#)》应用报告
- 德州仪器 (TI), 《[PowerPAD™ 速成](#)》应用报告
- 德州仪器 (TI), 《[电流再循环和衰减模式](#)》应用报告
- 德州仪器 (TI), 《[计算电机驱动器的功耗](#)》应用报告
- 德州仪器 (TI), 《[了解电机驱动器电流额定值](#)》应用报告

### 11.2 接收文档更新通知

要接收文档更新通知, 请转至 [TI.com](http://TI.com) 上的器件产品文件夹。单击右上角的 [通知我](#) 进行注册, 即可每周接收产品信息更改摘要。有关更改的详细信息, 请查看任何已修订文档中包含的修订历史记录。

### 11.3 社区资源

下列链接提供到 TI 社区资源的连接。链接的内容由各个分销商“按照原样”提供。这些内容并不构成 TI 技术规范, 并且不一定反映 TI 的观点; 请参阅 TI 的 [《使用条款》](#)。

**TI E2E™ 在线社区** [TI 的工程师对工程师 \(E2E\) 社区](#)。此社区的创建目的在于促进工程师之间的协作。在 [e2e.ti.com](http://e2e.ti.com) 中, 您可以咨询问题、分享知识、拓展思路并与同行工程师一道帮助解决问题。

**设计支持** [TI 参考设计支持](#) 可帮助您快速查找有帮助的 E2E 论坛、设计支持工具以及技术支持的联系信息。

### 11.4 商标

AutoTune, PowerPAD, E2E are trademarks of Texas Instruments.  
All other trademarks are the property of their respective owners.

### 11.5 静电放电警告



这些装置包含有限的内置 ESD 保护。存储或装卸时, 应将导线一起截短或将装置放置于导电泡棉中, 以防止 MOS 门极遭受静电损伤。

## 11.6 Glossary

[SLYZ022](#) — *TI Glossary*.

This glossary lists and explains terms, acronyms, and definitions.

## 12 机械、封装和可订购信息

以下页面包含机械、封装和可订购信息。这些信息是指定器件的最新可用数据。这些数据如有变更, 恕不另行通知和修订此文档。如欲获取此数据表的浏览器版本, 请参阅左侧的导航。

**PACKAGING INFORMATION**

Orderable Device	Status (1)	Package Type	Package Drawing	Pins	Package Qty	Eco Plan (2)	Lead finish/ Ball material (6)	MSL Peak Temp (3)	Op Temp (°C)	Device Marking (4/5)	Samples
DRV8880PWP	ACTIVE	HTSSOP	PWP	28	50	RoHS & Green	NIPDAU	Level-3-260C-168 HR	-40 to 125	DRV8880	<a href="#">Samples</a>
DRV8880PWPR	ACTIVE	HTSSOP	PWP	28	2000	RoHS & Green	NIPDAU	Level-3-260C-168 HR	-40 to 125	DRV8880	<a href="#">Samples</a>
DRV8880RHRR	ACTIVE	WQFN	RHR	28	3000	RoHS & Green	NIPDAU	Level-2-260C-1 YEAR	-40 to 125	DRV8880	<a href="#">Samples</a>
DRV8880RHRT	ACTIVE	WQFN	RHR	28	250	RoHS & Green	NIPDAU	Level-2-260C-1 YEAR	-40 to 125	DRV8880	<a href="#">Samples</a>

(1) The marketing status values are defined as follows:

**ACTIVE:** Product device recommended for new designs.

**LIFEBUY:** TI has announced that the device will be discontinued, and a lifetime-buy period is in effect.

**NRND:** Not recommended for new designs. Device is in production to support existing customers, but TI does not recommend using this part in a new design.

**PREVIEW:** Device has been announced but is not in production. Samples may or may not be available.

**OBSOLETE:** TI has discontinued the production of the device.

(2) **RoHS:** TI defines "RoHS" to mean semiconductor products that are compliant with the current EU RoHS requirements for all 10 RoHS substances, including the requirement that RoHS substance do not exceed 0.1% by weight in homogeneous materials. Where designed to be soldered at high temperatures, "RoHS" products are suitable for use in specified lead-free processes. TI may reference these types of products as "Pb-Free".

**RoHS Exempt:** TI defines "RoHS Exempt" to mean products that contain lead but are compliant with EU RoHS pursuant to a specific EU RoHS exemption.

**Green:** TI defines "Green" to mean the content of Chlorine (Cl) and Bromine (Br) based flame retardants meet JS709B low halogen requirements of <=1000ppm threshold. Antimony trioxide based flame retardants must also meet the <=1000ppm threshold requirement.

(3) MSL, Peak Temp. - The Moisture Sensitivity Level rating according to the JEDEC industry standard classifications, and peak solder temperature.

(4) There may be additional marking, which relates to the logo, the lot trace code information, or the environmental category on the device.

(5) Multiple Device Markings will be inside parentheses. Only one Device Marking contained in parentheses and separated by a "-" will appear on a device. If a line is indented then it is a continuation of the previous line and the two combined represent the entire Device Marking for that device.

(6) Lead finish/Ball material - Orderable Devices may have multiple material finish options. Finish options are separated by a vertical ruled line. Lead finish/Ball material values may wrap to two lines if the finish value exceeds the maximum column width.

**Important Information and Disclaimer:**The information provided on this page represents TI's knowledge and belief as of the date that it is provided. TI bases its knowledge and belief on information provided by third parties, and makes no representation or warranty as to the accuracy of such information. Efforts are underway to better integrate information from third parties. TI has taken and

continues to take reasonable steps to provide representative and accurate information but may not have conducted destructive testing or chemical analysis on incoming materials and chemicals. TI and TI suppliers consider certain information to be proprietary, and thus CAS numbers and other limited information may not be available for release.

In no event shall TI's liability arising out of such information exceed the total purchase price of the TI part(s) at issue in this document sold by TI to Customer on an annual basis.

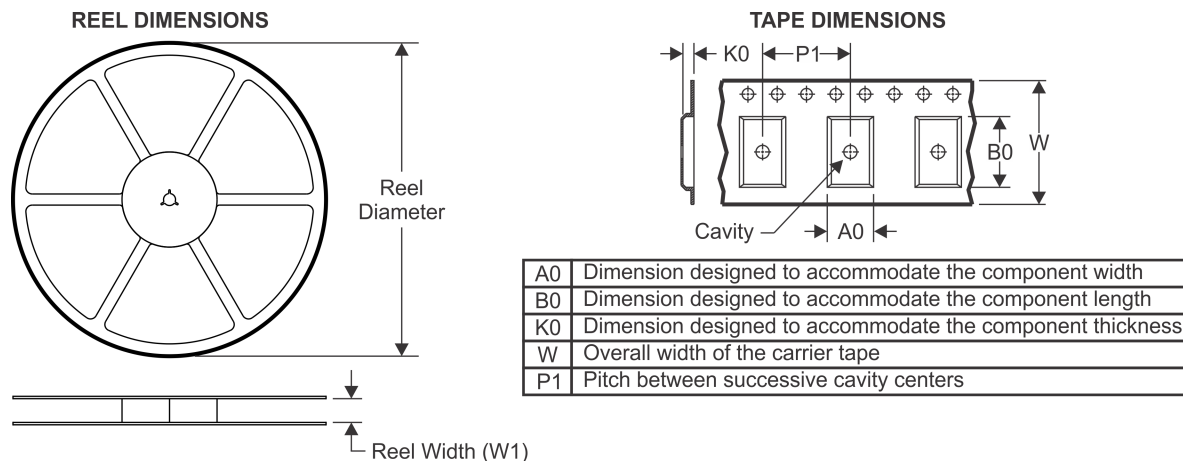
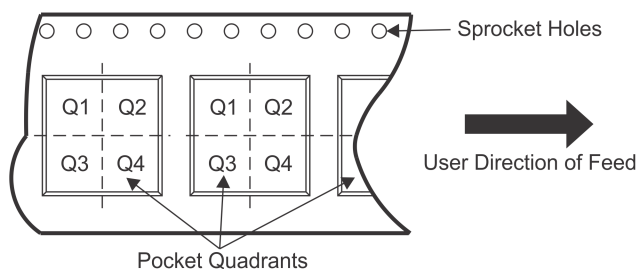
**TAPE AND REEL INFORMATION**

**QUADRANT ASSIGNMENTS FOR PIN 1 ORIENTATION IN TAPE**

\*All dimensions are nominal

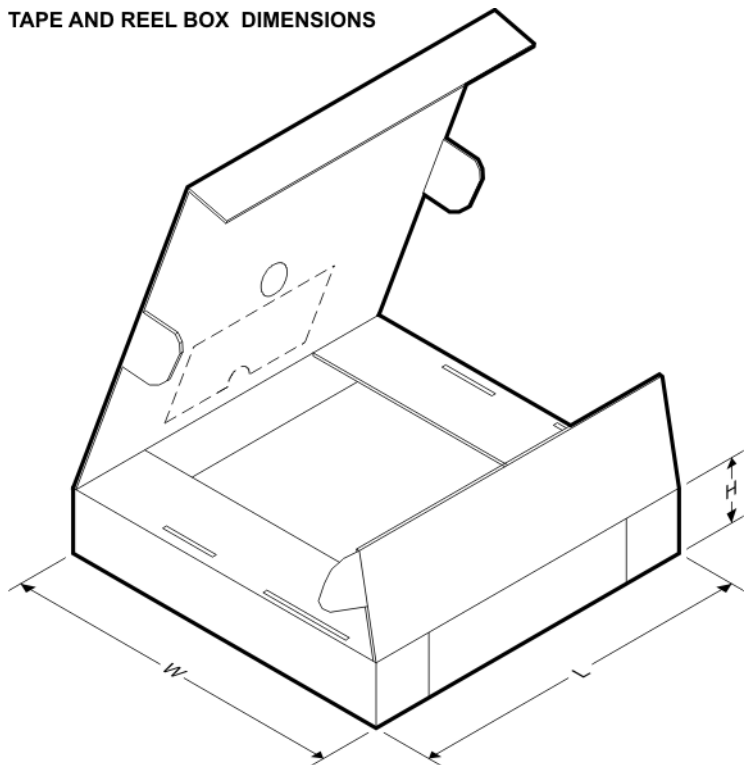
Device	Package Type	Package Drawing	Pins	SPQ	Reel Diameter (mm)	Reel Width W1 (mm)	A0 (mm)	B0 (mm)	K0 (mm)	P1 (mm)	W (mm)	Pin1 Quadrant
DRV8880PWPR	HTSSOP	PWP	28	2000	330.0	16.4	6.9	10.2	1.8	12.0	16.0	Q1
DRV8880RHRR	WQFN	RHR	28	3000	330.0	12.4	3.8	5.8	1.2	8.0	12.0	Q1
DRV8880RHRT	WQFN	RHR	28	250	180.0	12.4	3.8	5.8	1.2	8.0	12.0	Q1

**TAPE AND REEL BOX DIMENSIONS**

\*All dimensions are nominal

Device	Package Type	Package Drawing	Pins	SPQ	Length (mm)	Width (mm)	Height (mm)
DRV8880PWPR	HTSSOP	PWP	28	2000	350.0	350.0	43.0
DRV8880RHRR	WQFN	RHR	28	3000	367.0	367.0	35.0
DRV8880RHRT	WQFN	RHR	28	250	210.0	185.0	35.0

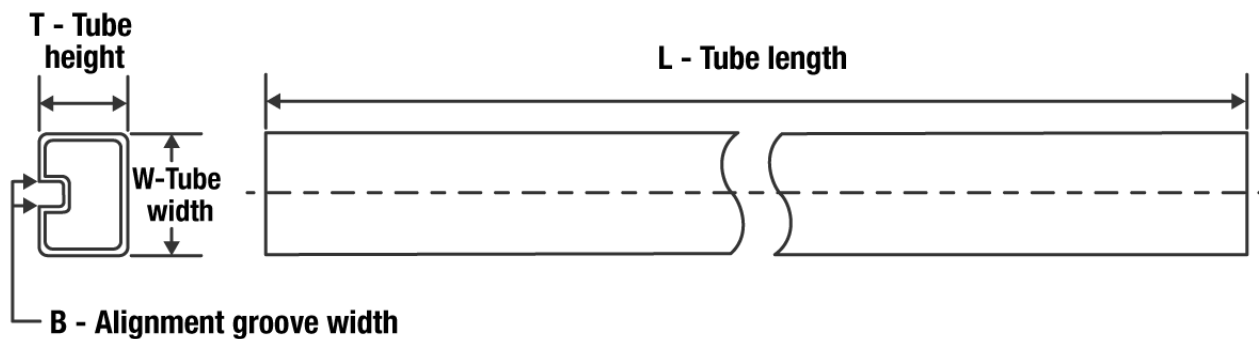
**TUBE**

\*All dimensions are nominal

Device	Package Name	Package Type	Pins	SPQ	L (mm)	W (mm)	T (μm)	B (mm)
DRV8880PWP	PWP	HTSSOP	28	50	530	10.2	3600	3.5

## GENERIC PACKAGE VIEW

**RHR 28**

**WQFN - 0.8 mm max height**

3.5 x 5.5, 0.5 mm pitch

PLASTIC QUAD FLATPACK - NO LEAD

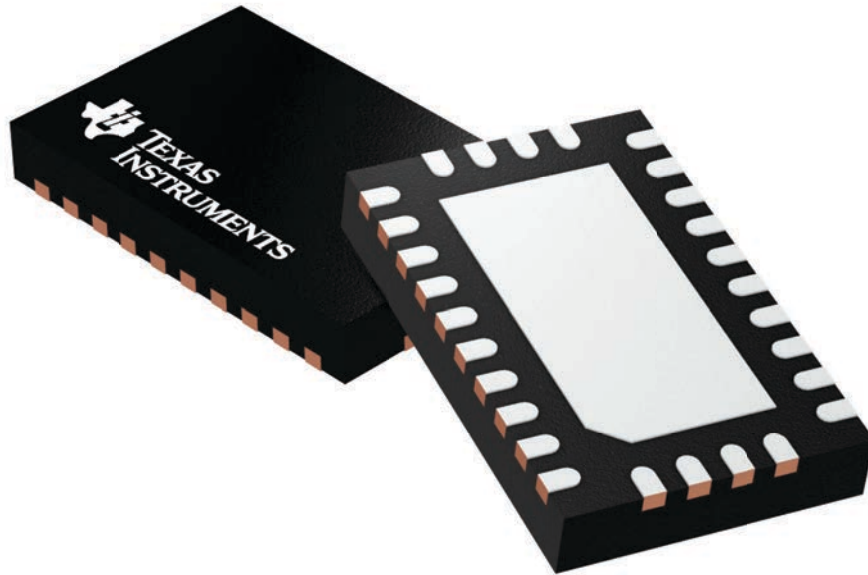

Images above are just a representation of the package family, actual package may vary.  
Refer to the product data sheet for package details.

4210249/B

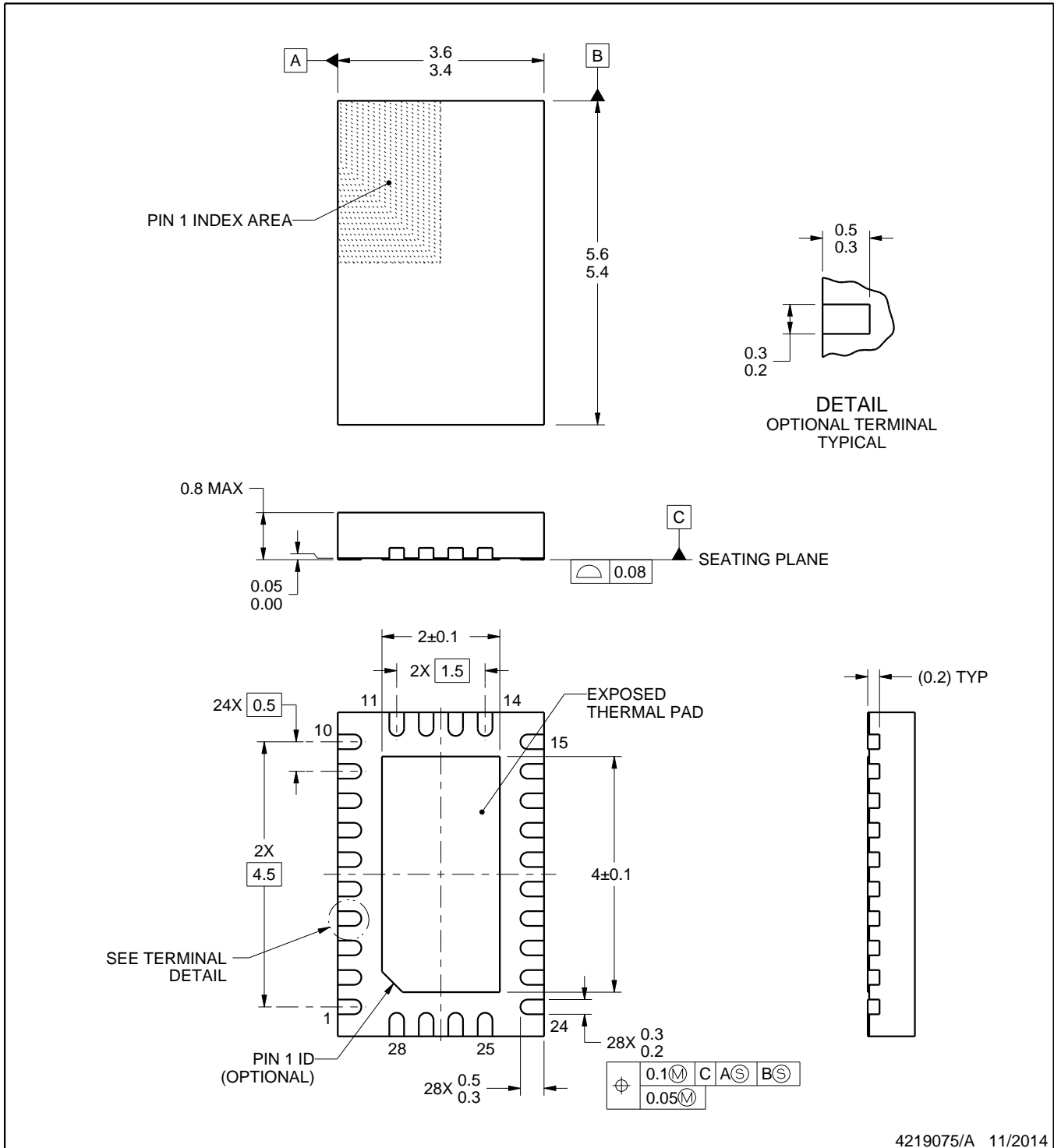

4219075/A 11/2014

NOTES:

1. All linear dimensions are in millimeters. Any dimensions in parenthesis are for reference only. Dimensioning and tolerancing per ASME Y14.5M.
2. This drawing is subject to change without notice.
3. The package thermal pad must be soldered to the printed circuit board for thermal and mechanical performance.

# EXAMPLE BOARD LAYOUT

RHR0028A

WQFN - 0.8 mm max height

PLASTIC QUAD FLATPACK - NO LEAD

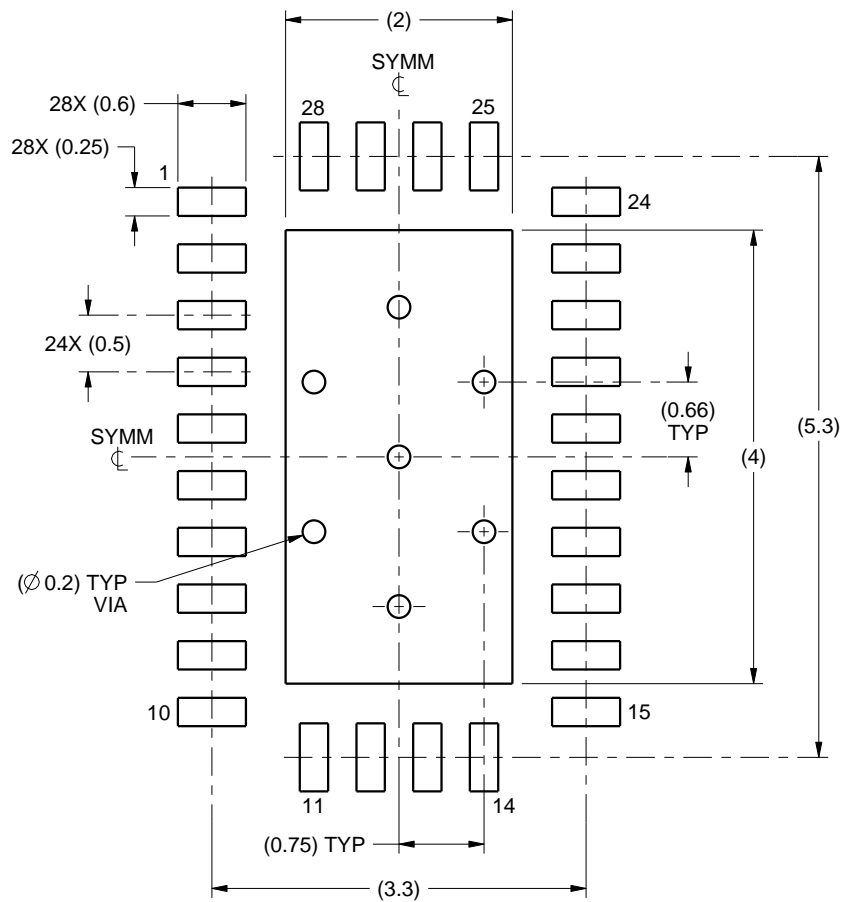

LAND PATTERN EXAMPLE  
SCALE:15X

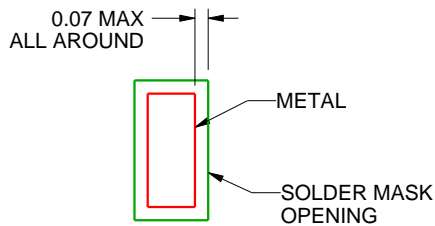

NON SOLDER MASK  
DEFINED  
(PREFERRED)

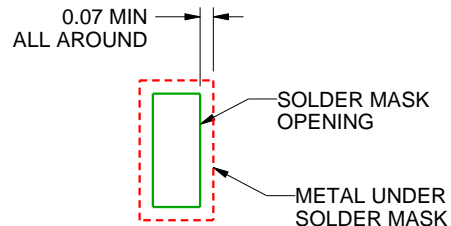

SOLDER MASK  
DEFINED

## SOLDER MASK DETAILS

4219075/A 11/2014

NOTES: (continued)

- This package is designed to be soldered to a thermal pad on the board. For more information, see Texas Instruments literature number SLUA271 ([www.ti.com/lit/slua271](http://www.ti.com/lit/slua271)).

# EXAMPLE STENCIL DESIGN

RHR0028A

WQFN - 0.8 mm max height

PLASTIC QUAD FLATPACK - NO LEAD

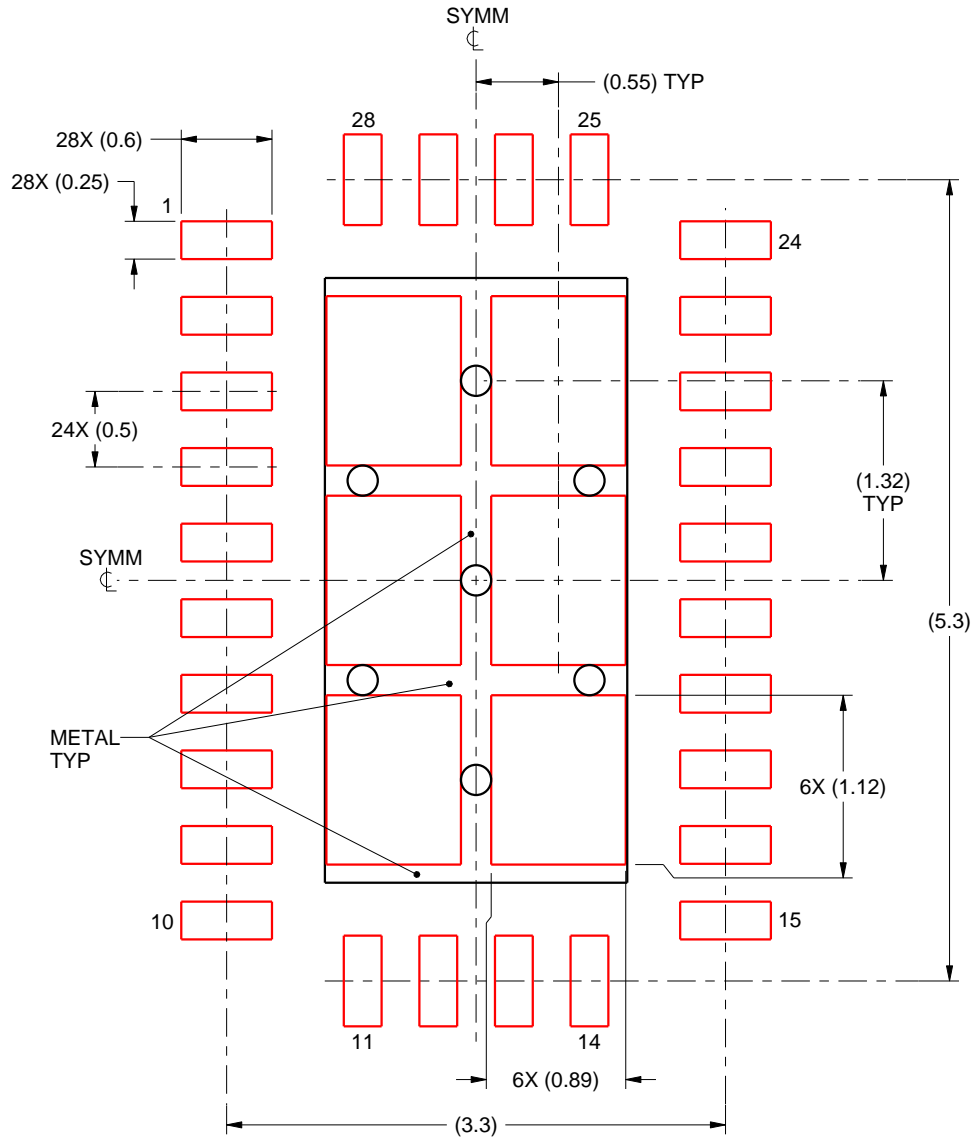

**SOLDER PASTE EXAMPLE**  
BASED ON 0.125 mm THICK STENCIL

EXPOSED PAD  
75% PRINTED SOLDER COVERAGE BY AREA  
SCALE:20X

4219075/A 11/2014

NOTES: (continued)

5. Laser cutting apertures with trapezoidal walls and rounded corners may offer better paste release. IPC-7525 may have alternate design recommendations.

## GENERIC PACKAGE VIEW

**PWP 28**

**PowerPAD™ TSSOP - 1.2 mm max height**

4.4 x 9.7, 0.65 mm pitch

SMALL OUTLINE PACKAGE

This image is a representation of the package family, actual package may vary.  
Refer to the product data sheet for package details.

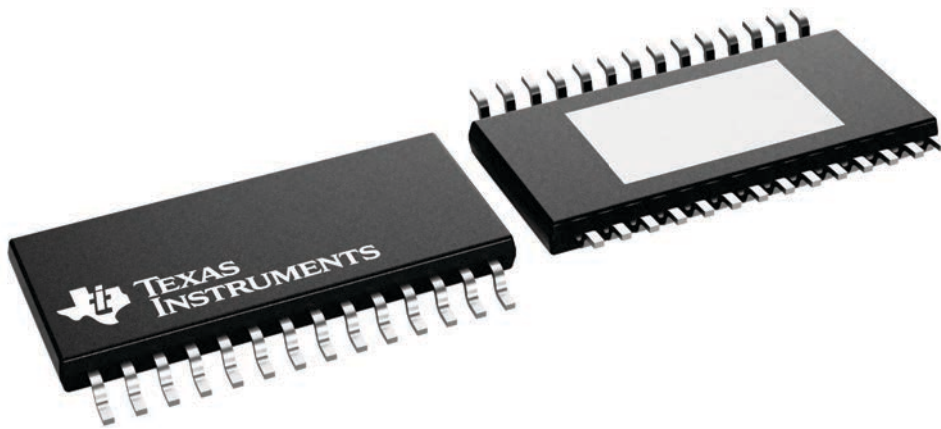

4224765/B

# PWP0028C

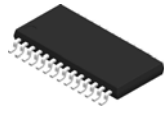

# PACKAGE OUTLINE

## PowerPAD™ TSSOP - 1.2 mm max height

SMALL OUTLINE PACKAGE

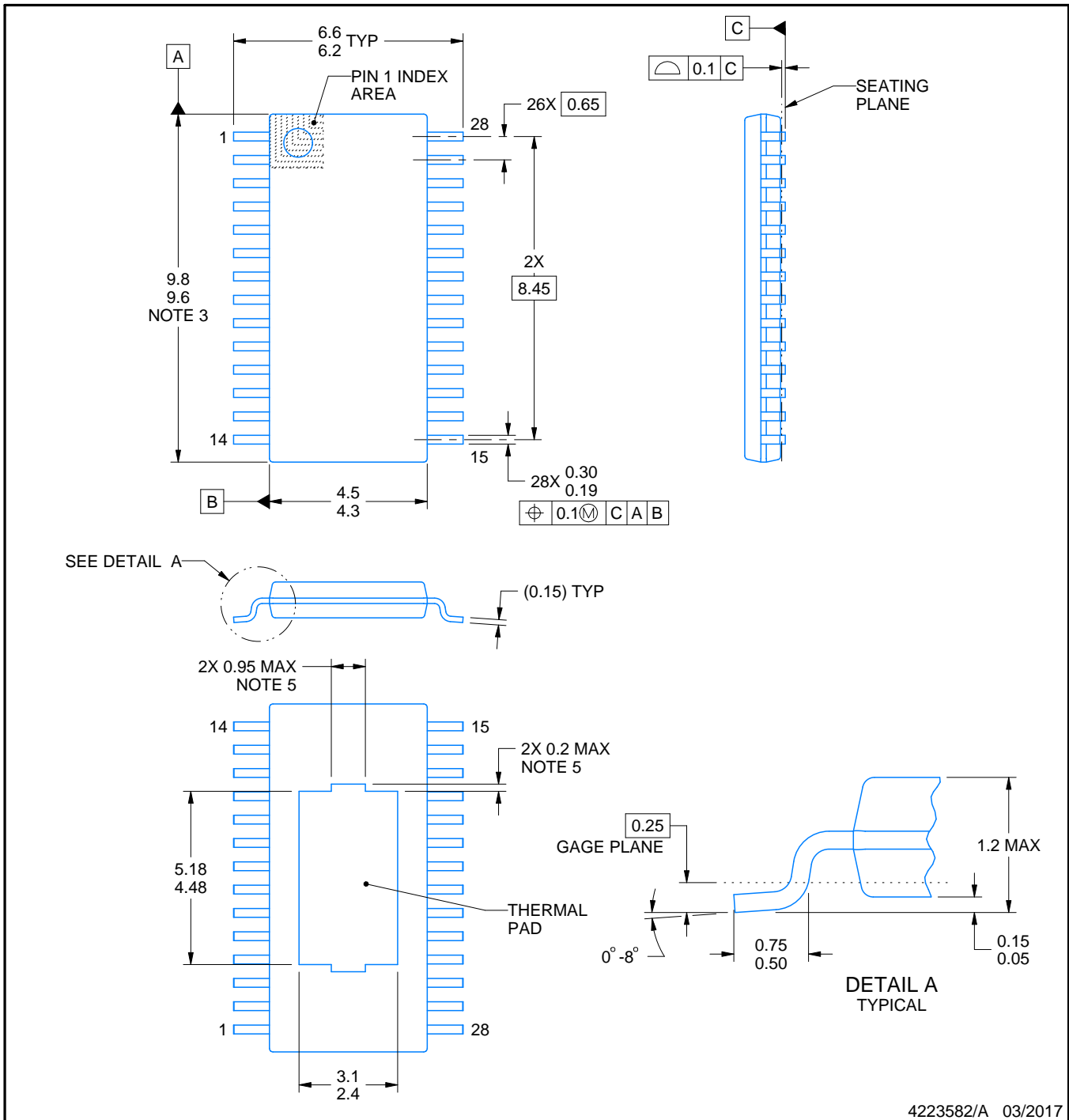

4223582/A 03/2017

### NOTES:

PowerPAD is a trademark of Texas Instruments.

1. All linear dimensions are in millimeters. Any dimensions in parenthesis are for reference only. Dimensioning and tolerancing per ASME Y14.5M.
2. This drawing is subject to change without notice.
3. This dimension does not include mold flash, protrusions, or gate burrs. Mold flash, protrusions, or gate burrs shall not exceed 0.15 mm per side.
4. Reference JEDEC registration MO-153.
5. Features may differ or may not be present.

# EXAMPLE BOARD LAYOUT

PWP0028C

PowerPAD™ TSSOP - 1.2 mm max height

SMALL OUTLINE PACKAGE

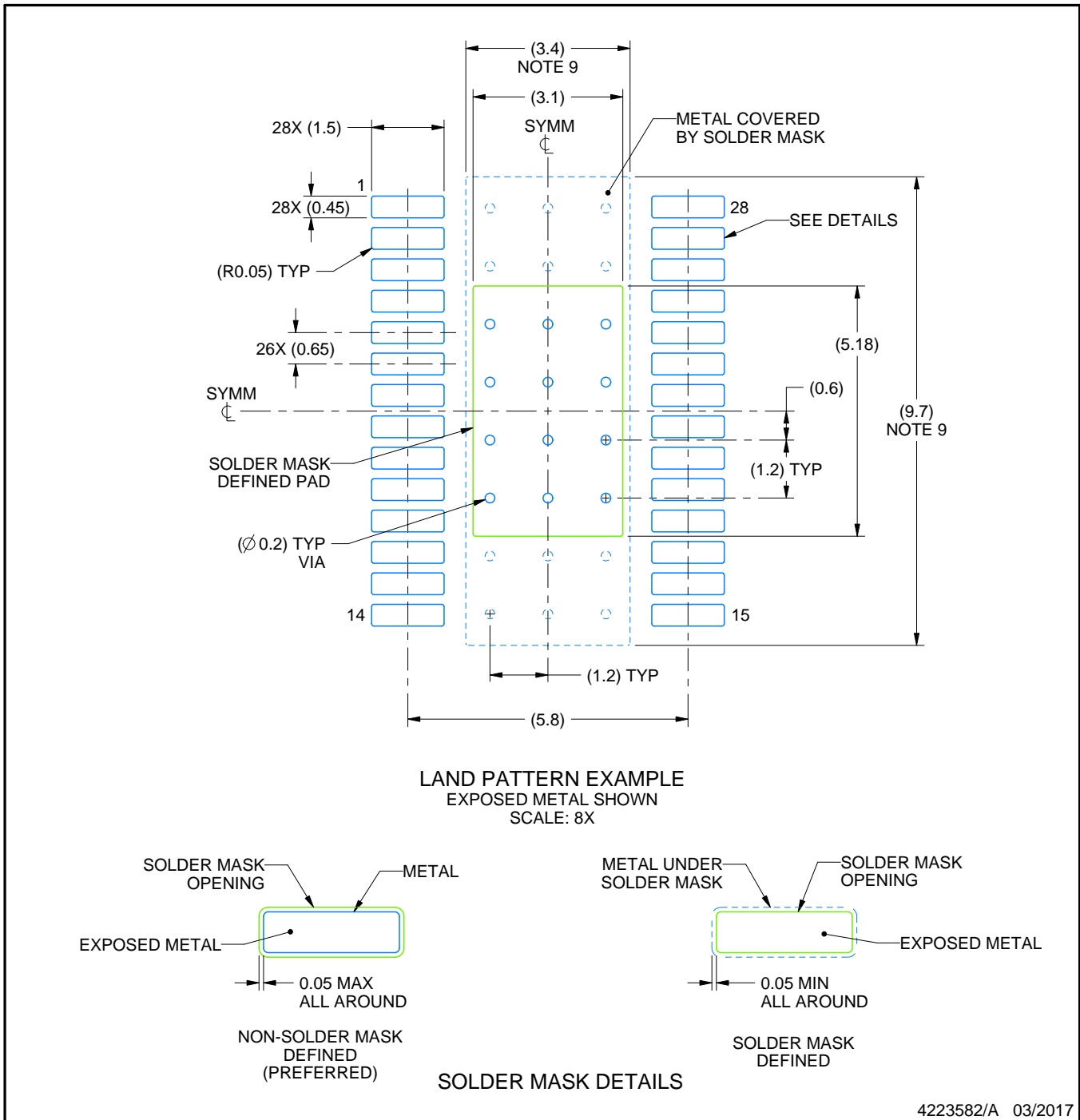

NOTES: (continued)

6. Publication IPC-7351 may have alternate designs.
7. Solder mask tolerances between and around signal pads can vary based on board fabrication site.
8. This package is designed to be soldered to a thermal pad on the board. For more information, see Texas Instruments literature numbers SLMA002 ([www.ti.com/lit/slma002](http://www.ti.com/lit/slma002)) and SLMA004 ([www.ti.com/lit/slma004](http://www.ti.com/lit/slma004)).
9. Size of metal pad may vary due to creepage requirement.
10. Vias are optional depending on application, refer to device data sheet. It is recommended that vias under paste be filled, plugged or tented.

# EXAMPLE STENCIL DESIGN

PWP0028C

PowerPAD™ TSSOP - 1.2 mm max height

SMALL OUTLINE PACKAGE

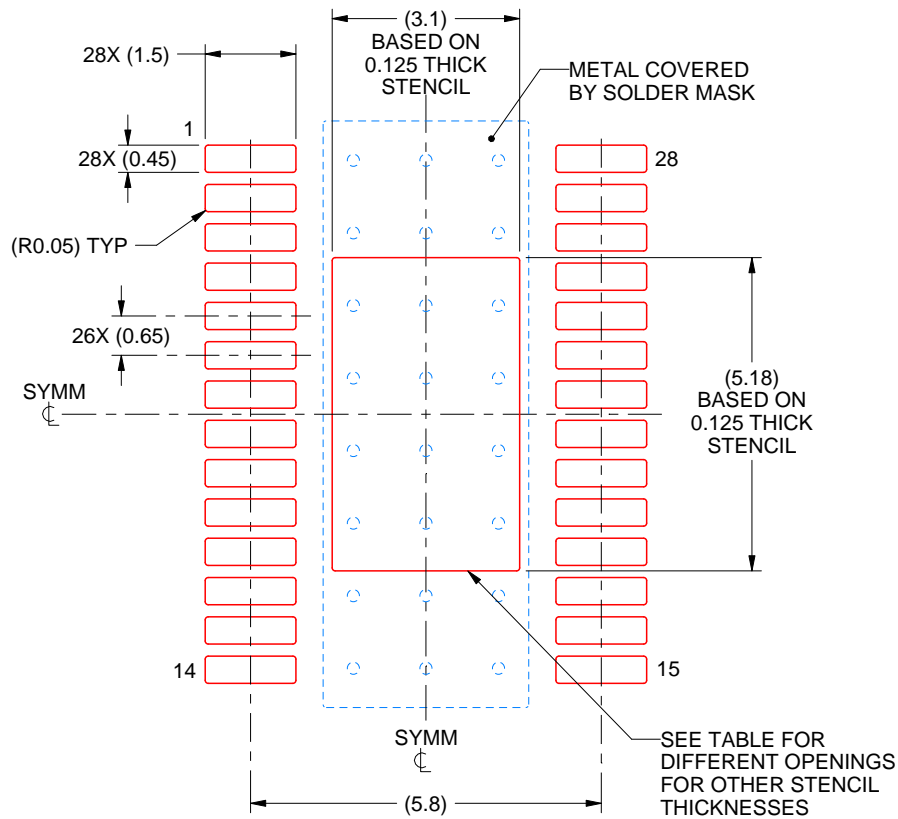

**SOLDER PASTE EXAMPLE**  
 BASED ON 0.125 mm THICK STENCIL  
 SCALE: 8X

STENCIL THICKNESS	SOLDER STENCIL OPENING
0.1	3.47 X 5.79
0.125	3.10 X 5.18 (SHOWN)
0.15	2.83 X 4.73
0.175	2.62 X 4.38

4223582/A 03/2017

NOTES: (continued)

11. Laser cutting apertures with trapezoidal walls and rounded corners may offer better paste release. IPC-7525 may have alternate design recommendations.
12. Board assembly site may have different recommendations for stencil design.

## 重要声明和免责声明

TI“按原样”提供技术和可靠性数据（包括数据表）、设计资源（包括参考设计）、应用或其他设计建议、网络工具、安全信息和其他资源，不保证没有瑕疵且不做任何明示或暗示的担保，包括但不限于对适销性、某特定用途方面的适用性或不侵犯任何第三方知识产权的暗示担保。

这些资源可供使用 TI 产品进行设计的熟练开发人员使用。您将自行承担以下全部责任：(1) 针对您的应用选择合适的 TI 产品，(2) 设计、验证并测试您的应用，(3) 确保您的应用满足相应标准以及任何其他功能安全、信息安全、监管或其他要求。

这些资源如有变更，恕不另行通知。TI 授权您仅可将这些资源用于研发本资源所述的 TI 产品的应用。严禁对这些资源进行其他复制或展示。您无权使用任何其他 TI 知识产权或任何第三方知识产权。您应全额赔偿因在这些资源的使用中对 TI 及其代表造成的任何索赔、损害、成本、损失和债务，TI 对此概不负责。

TI 提供的产品受 [TI 的销售条款](#) 或 [ti.com](#) 上其他适用条款/TI 产品随附的其他适用条款的约束。TI 提供这些资源并不会扩展或以其他方式更改 TI 针对 TI 产品发布的适用的担保或担保免责声明。

TI 反对并拒绝您可能提出的任何其他或不同的条款。

邮寄地址：Texas Instruments, Post Office Box 655303, Dallas, Texas 75265

Copyright © 2022，德州仪器 (TI) 公司